

AD-A120 470

ANALYTICAL AND EXPERIMENTAL INVESTIGATION OF TURBINE  
BLADE DAMPING(U) DAYTON UNIV OH RESEARCH INST  
R J DOMINIC ET AL. AUG 82 UDR-TR-82-39 AFOSR-TR-82-0911  
F49620-81-K-0014 F/G 21/5

1/1

UNCLASSIFIED

NL

END

FILM  
+  
DTIC

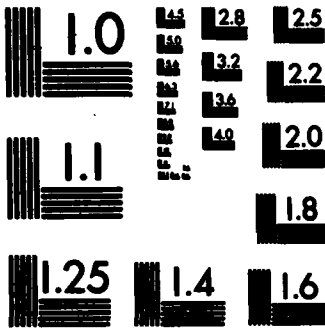

MICROCOPY RESOLUTION TEST CHART  
NATIONAL BUREAU OF STANDARDS-1963-A

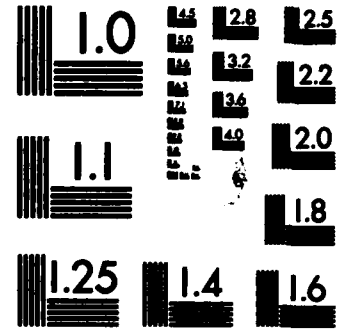

MICROCOPY RESOLUTION TEST CHART  
NATIONAL BUREAU OF STANDARDS-1963-A

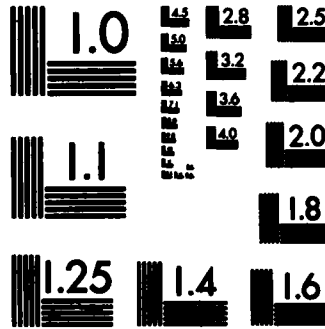

MICROCOPY RESOLUTION TEST CHART  
NATIONAL BUREAU OF STANDARDS-1963-A

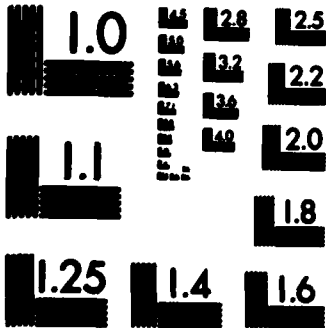

MICROCOPY RESOLUTION TEST CHART  
NATIONAL BUREAU OF STANDARDS-1963-A

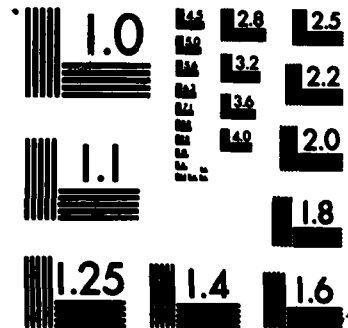

MICROCOPY RESOLUTION TEST CHART  
NATIONAL BUREAU OF STANDARDS-1963-A

AFOSR-TR- 82-0911

4

UDR-TR-82-39

ANALYTICAL AND EXPERIMENTAL INVESTIGATION  
OF TURBINE BLADE DAMPING  
FINAL REPORT

F49620-81-K-0014

Robert J. Dominic  
Philip A. Graf  
B. Basava Raju



DTIC  
ELECTRONIC  
S OCT 19 1982  
F

Approved for public release;  
distribution unlimited.

UNIVERSITY OF DAYTON  
DAYTON, OHIO.

Prepared for:

Air Force Office of Scientific Research  
Bolling Air Force Base, D.C. 20332

AD A120470

DTIC FILE COPY

88 10 18 083

UNCLASSIFIED

SECURITY CLASSIFICATION OF THIS PAGE (When Data Entered)

REPORT DOCUMENTATION PAGE		READ INSTRUCTIONS BEFORE COMPLETING FORM
1. REPORT NUMBER <b>AOSR-TR- 82-0911</b>	2. GOVT ACCESSION NO. <b>AD-A120470</b>	3. RECIPIENT'S CATALOG NUMBER
4. TITLE (and Subtitle) <b>ANALYTICAL AND EXPERIMENTAL INVESTIGATION OF TURBINE BLADE DAMPING</b>		5. TYPE OF REPORT & PERIOD COVERED <b>FINAL 30 Jun 81 - 29 Jun 82</b>
		6. PERFORMING ORG. REPORT NUMBER <b>UDR-TR-82-39</b>
7. AUTHOR(s) <b>Robert J. Dominic Philip A. Graf B. Basava Raju</b>		8. CONTRACT OR GRANT NUMBER(s)  <b>F49620-81-K-0014</b>
9. PERFORMING ORGANIZATION NAME AND ADDRESS <b>University of Dayton Research Institute 300 College Park Avenue Dayton, Ohio 45469</b>		10. PROGRAM ELEMENT, PROJECT, TASK AREA & WORK UNIT NUMBERS <b>61102F 2307/B1</b>
11. CONTROLLING OFFICE NAME AND ADDRESS <b>Air Force Office of Scientific Research/ Bolling Air Force Base, D.C. 20332</b>		12. REPORT DATE <b>August, 1982</b>
		13. NUMBER OF PAGES <b>49</b>
14. MONITORING AGENCY NAME & ADDRESS (if different from Controlling Office)		15. SECURITY CLASS. (of this report)  <b>Unclassified</b>
		15a. DECLASSIFICATION/DOWNGRADING SCHEDULE
16. DISTRIBUTION STATEMENT (of this Report)  <b>Approved for Public Release; Distribution Unlimited.</b>		
17. DISTRIBUTION STATEMENT (of the abstract entered in Block 20, if different from Report)		
18. SUPPLEMENTARY NOTES		
19. KEY WORDS (Continue on reverse side if necessary and identify by block number) <b>Friction, Friction Damping, Friction Testing, Coefficient of Friction, Evaluation, Turbine Blade Damping, Blade to Disk Damping, Damped Turbine Blade Modeling, Damped Blade Vibration Analysis, Lumped Mass Analysis, Lumped Mass Computer Program, Vibration Testing, Vibration Analysis</b>		
20. ABSTRACT (Continue on reverse side if necessary and identify by block number) <b>Simulated blade to disk damping of a model turbine blade was evaluated, both experimentally and analytically. Experimental work was performed with a unique apparatus that introduced friction damping at the blade platform. Analytical work was performed with a computer program based on the lumped mass theoretical analysis developed by Muszynska and Jones. A test was performed also to evaluate the coefficient of friction at the test setup conditions. Experimental and analytical studies</b>		

DD FORM 1473  
1 JAN 73

EDITION OF 1 NOV 65 IS OBSOLETE

UNCLASSIFIED

SECURITY CLASSIFICATION OF THIS PAGE (When Data Entered)

~~UNCLASSIFIED~~

SECURITY CLASSIFICATION OF THIS PAGE (When Data Entered)

Block 20.

showed good qualitative agreement. Very high damping was achieved by means of friction. Blade response to forced vibration was reduced by two orders of magnitude over the frequency range of the first two bending modes of the blade at the optimum friction damping conditions. For the tested blade configuration, optimum damping occurred when the friction force ( $\mu N$ ) was equal to or slightly greater than the excitation force.

*Mines*

~~UNCLASSIFIED~~

SECURITY CLASSIFICATION OF THIS PAGE (When Data Entered)

UDR-TR-82-39

**ANALYTICAL AND EXPERIMENTAL INVESTIGATION  
OF TURBINE BLADE DAMPING  
FINAL REPORT**

**Robert J. Dominic  
Philip A. Graf  
B. Basava Raju**

**University of Dayton  
Research Institute  
Dayton, Ohio 45469**

**AIR FORCE OFFICE OF SCIENTIFIC RESEARCH (AFSC)  
NOTICE OF TRANSMITTAL TO DTIC  
This technical report has been reviewed and is  
approved for public release IAW AFR 190-12.  
Distribution is unlimited.  
MATTHEW J. KERPER  
Chief, Technical Information Division**

**Prepared for:**

**Air Force Office of Scientific Research  
Bolling Air Force Base, D.C. 20332**

FOREWORD

The work described in this report was funded by the Air Force Office of Scientific Research with Mr. Tony Amos as the project monitor. The work was performed by the University of Dayton Research Institute (UDRI), Aerospace Mechanics Division, (Mr. Dale H. Whitford - division supervisor), Vibration Analysis and Control Group ( Mr. Michael L. Drake - group leader). The authors wish to acknowledge the many contributions of Dr. Agnieszka Muszynska, now of Bently Nevada Corporation, to the program. The efforts of Mr. Thomas W. Held of UDRI in adapting the analytical program to the University's VAX 11/780 computer system are also gratefully acknowledged. This report covers work conducted during the period of July 1981 to June 1982.



Accession For	
NTIS GRA&I	<input checked="" type="checkbox"/>
DTIC TAB	<input type="checkbox"/>
Unannounced	<input type="checkbox"/>
Justification	
By _____	
Distribution/	
Availability Codes	
Dist	Avail and/or Special
A	

## TABLE OF CONTENTS

<u>SECTION</u>		<u>PAGE</u>
1	INTRODUCTION	1
2	VIBRATING BEAM TESTS	3
3	COEFFICIENT OF FRICTION EVALUATIONS	15
4	ANALYSIS OF BEAM RESPONSE BY THE LUMPED MASS METHOD	21
5	PRESENTATION AND DISCUSSION OF RESULTS	25
6	CONCLUSIONS	43
7	RECOMMENDATIONS	44
	REFERENCES	46

## LIST OF ILLUSTRATIONS

<u>FIGURE</u>		<u>PAGE</u>
1	Test Beam With Straight Platform	4
2	Conceptual Sketch of Vibrating Beam Test Setup	6
3	Photograph of Vibrating Beam Test Setup	7
4	Support Block and Rectangular and Tapered Rub Blocks	8
5	Curved Platform Beam	10
6	Curved Surface Rub Block	10
7	Beams With Flat Surface (Left) and Curved Surface Platforms	11
8	Rectangular, Tapered, and Curved Surface Rub Blocks	12
9	Vibrating Beam Instrumentation System	13
10	Typical Set of Frequency Sweeps for One Test Condition	14
11	Modal Test Data From Impact Test	16
12	Coefficient of Friction ( $\mu$ ) Evaluation Test Setup	18
13	Coefficient of Friction Instrumentation Setup	19
14	Coefficient of Friction Evaluation Data Chart	20
15	Physical Model of Single-Blade System	23
16	Vibration Response of Straight Platform Beam with Rectangular Rub Block - $\mu=0.24$	27
17	Vibration Response of Straight Platform Beam with Rectangular Rub Block - $\mu=0.19$	28

LIST OF ILLUSTRATIONS (continued)

<u>FIGURE</u>		<u>PAGE</u>
18	Vibration Response of Straight Platform Beam with Tapered Rub Block - $\mu=0.24$	29
19	Vibration Response of Straight Platform Beam with Tapered Rub Block - $\mu=0.19$	30
20	Vibration Response of Curved Platform Beam with Curved Surface Rub Block - $\mu=0.24$	31
21	Vibration Response of Curved Platform Beam with Curved Surface Rub Block - $\mu=0.19$	32
22	Vibration Response of Curved Platform Beam with Curved Surface Rub Block - Viscoelastic Damping Layer	35
23	Computed Vibration Response of Lumped Mass Beam with $\eta=0.002$ , $\mu=0.24$ .	37
24	Computed Vibration Response of Lumped Mass Beam with $\eta=0.002$ , $\mu=0.19$ .	38
25	Computed Vibration Response of Lumped Mass Beam with $\eta=0.02$ , $\mu=0.24$	39
26	Computed Vibration Response of Lumped Mass Beam with $\eta=0.02$ , $\mu=0.19$ .	40
27	Computed Vibration Response of Lumped Mass Beam with $\eta=0.2$ , $\mu=0.24$ .	41
28	Computed Vibration Response of Lumped Mass Beam with $\eta=0.2$ , $\mu=0.19$ .	42

## 1. INTRODUCTION

Vibration problems in fan, compressor, and turbine blades of jet engines occur more frequently as the performance requirements increase. This is especially true for the newer high thrust-to-weight-ratio engines, and will be especially severe for blades with variable geometry. Efforts to design around resonant vibration problems to the maximum extent possible are always necessary, but in the absence of a rational method for predicting the damping in the various modes of vibration it will always be difficult to be completely successful. Hence, design changes incorporated for reducing stresses can cause unpredictable reductions in modal damping which cancel the expected reduction in stress level. Furthermore, the random variation of modal damping from blade to blade in a single disc is so great (a factor of five or more) that even highly significant changes of stress resulting from design changes can be negated. This means that research into the sources of blade damping, as well as into means of increasing that damping, is currently attracting considerable attention.

One important damping mechanism is the sliding friction between mating surfaces on adjacent blades, or between the disc and the blades. The phenomena involved are highly nonlinear, and many analytical techniques and experimental methods have been reported in recent times. Goodman and Klump<sup>[1,2]</sup> discuss slip between pressfitted beams. Williams and Earles have examined analytically and experimentally the effect of slip on the response of a simple cantilevered beam with integral "clippers"<sup>[3,4]</sup>. Beards and Williams studied the interfacial slip in joints<sup>[5]</sup>. Some other relevant works are described in References 6 to 11.

Muszynska and Jones have proposed a discrete model based on lumped masses to predict the dynamic response of a single jet engine turbine or compressor blade to harmonic excitation by an external force and with restraint provided by a dry friction link

to ground (References 12-20). The discrete model is then used as a basis to characterize the nonlinear response of a set of several blades connected at their roots to a rigid disk, and having dry friction coupling from blade to blade and from blade to ground. The nonlinear differential equations of motion of the system are transformed into a set of nonlinear algebraic equations which are solved numerically using the iterative method.

The finite element method was used to analytically predict vibration frequencies, mode shapes, and system damping of a single shrouded fan blade using the NASTRAN computer program (Reference 21). Other relevant work based on finite element methods is reported in References 22 to 24.

Some effects of interface preparation on friction damping in joints are reported by Beards<sup>[26]</sup>. Some of the experimental work on material damping and vibration of turbine blades are discussed in References 27 to 31.

The purpose of this program effort was to perform a combined analytical/experimental investigation to study the influence of friction applied at the platform of a cantilever beam on the dynamic response behavior under harmonic excitation. The test beam was supported at the end block, simulating centrifugal force blade clamp-up at the disk during operating conditions. The platform at one-third span provided a friction rub surface during vibration, simulating blade platform mass and platform to disk friction damping. The purpose of the test was to study the dynamic response of the beam to an oscillating harmonic force applied at the beam tip in the fundamental mode of vibration. Normal load was applied in increments to the friction surface by a dead weight system that acted on the rub block. Tip acceleration measurements were made for a series of frequency sweeps from 50 to 500 Hz for each increment of the normal load, until lockup occurred.

An accurate measure of the coefficient of friction for each surface condition used in the blade tests was needed. Therefore, a test method was established to experimentally determine the coefficient of friction.

The analytical part of the investigation examined the use of a simple 2 mass-2 spring blade model with Coulomb type friction forces at the beam platform. The equations of motion derived on the basis of this simple model were solved by a method of harmonic balance assuming, in effect, that under cyclic excitation the blade will exhibit cyclic response at the same frequency. The solution so obtained was examined numerically to determine the frequency range over which the slip occurred and also to determine the optimal value of the friction force for which the tip amplitude of the beam had a minimum value. The qualitative agreement between analysis and experiment was found to be good for the fundamental mode of the blade.

The outcome of this investigation was that one can predict the dynamic response of a simple cantilever blade with the lumped mass method used in this program, provided the appropriate modal information was either measured through experimental test or predicted by more detailed analytical procedures such as finite element methods.

## 2. VIBRATING BEAM TESTS

The vibrating beam friction damping test mechanism consists of a clamped end cantilever beam designed to simulate a turbine blade operational system, with a friction rub block and its restraint system installed to simulate a blade-to-disk friction damper. There has been an evolution of both the test beam and the friction damper system during the program.

The test beam design is shown in Figure 1. The aluminum beam is designed to be clamped at the end block, simulating centrifugal force blade clamp-up at the disk during operating conditions. The concentrated mass at one-third span provides a friction rub surface during vibration, simulating blade platform mass and platform to disk friction damping. The blade has a first mode bending frequency, with no platform restraint, at

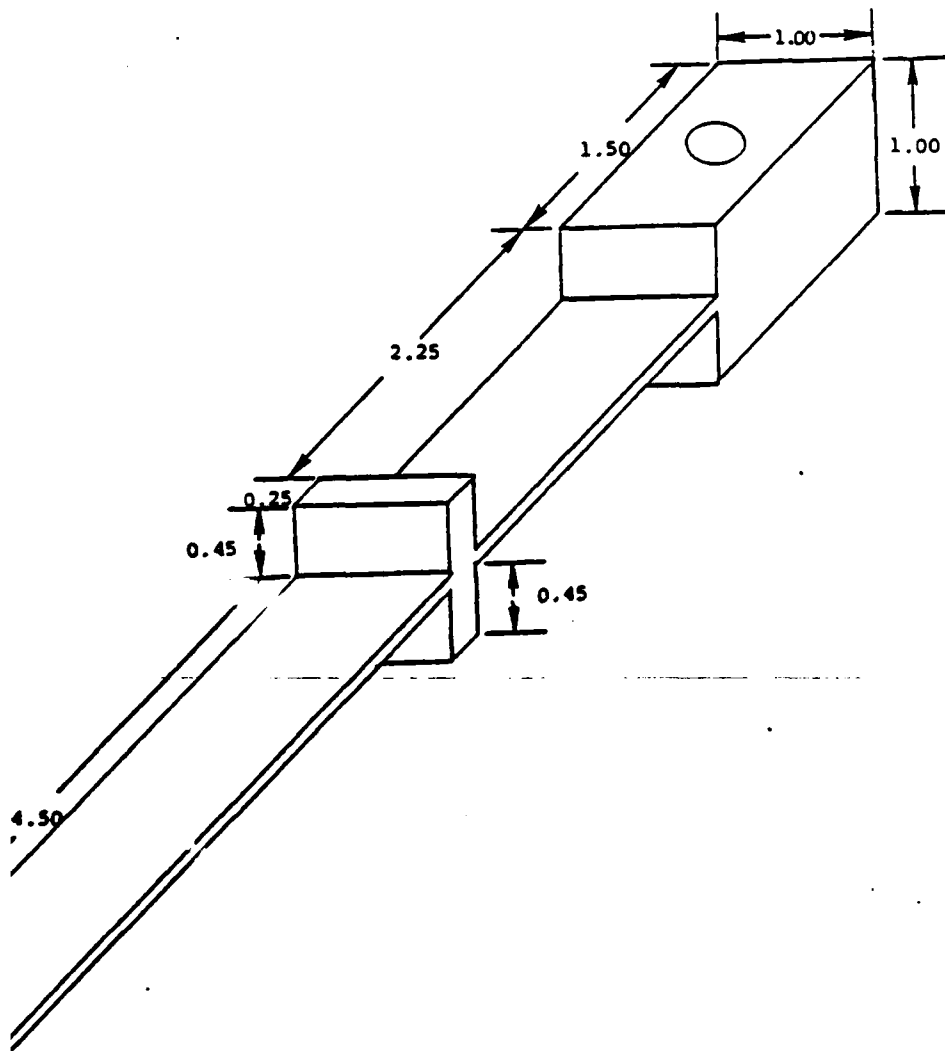

1. Test Beam with Straight Platform.

, with the second mode bending frequency occurring at 370 Hz. the platform is fully restrained, simulating lockup of a form friction damper, the first bending mode of the outboard on of the beam occurs at 160 Hz.

The platform damper system consists of a rub block that is restrained from moving in the plane of the friction surface by pins that are closely fitted to machined slots in a heavy stainless steel support block. The pins and slot surfaces are polished and lightly oiled. The rub block is free to rotate about the restraining pin axis. Normal load is applied to the friction surface by a dead weight system that acts on the rub block through thin copper wires looped around the rub block pins. A conceptual sketch and photograph of the system are presented in Figures 2 and 3 respectively.

The friction damper block was originally conceived as being a rectangular prism with a slot cut in the center for the free end of the beam to extend through. When that block was used in the vibration test setup, damping was extremely high at very low normal force loading. It was postulated that a large amount of vibration energy was being used to rotate the damper block as the beam rotated in bending about the fixed cantilever point. The block cross-section then was cut on a taper from the axis of rotation to the upper, lower, and side edges, (Figure 4) greatly reducing its rotational inertia. Data on friction damping was acquired over a range of normal loads for both the rectangular and the tapered rub blocks.

When data from both the rectangular and tapered rub block tests showed disagreement with data generated by computer runs of the lumped mass analytical program, it was decided to fabricate a beam and rub block having a mating curvature equal to the radius from the fixed cantilever point of the beam. To ensure no rotation would be induced in the rub block for low vibration amplitude of the platform, it was hoped the test data would compare with computer generated data for this system would show close

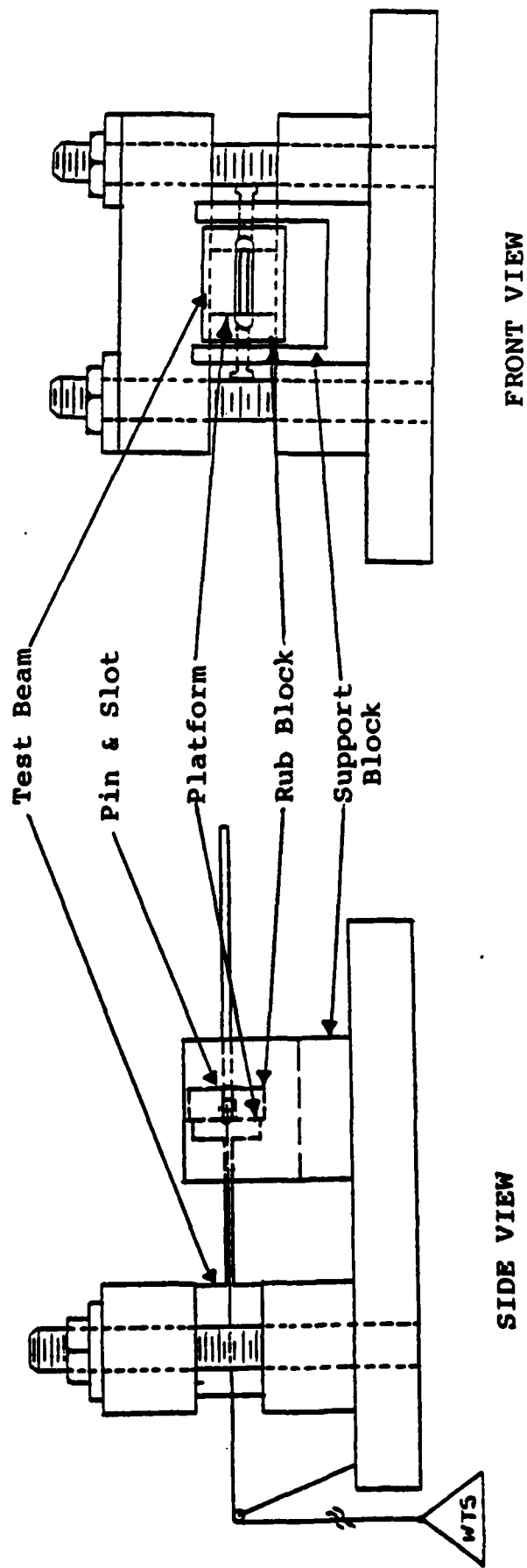

Figure 2. Vibrating Beam Test Setup.

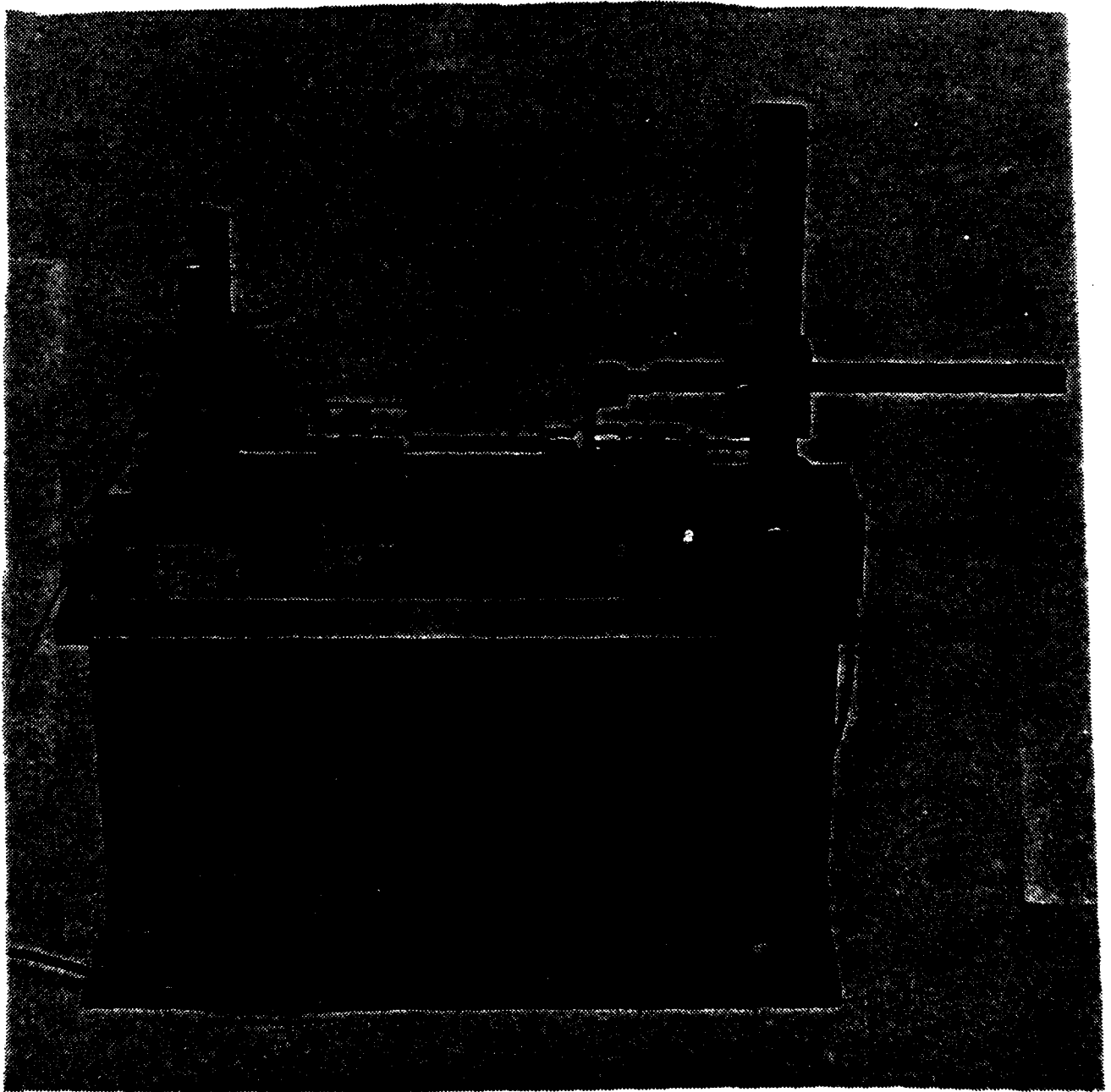
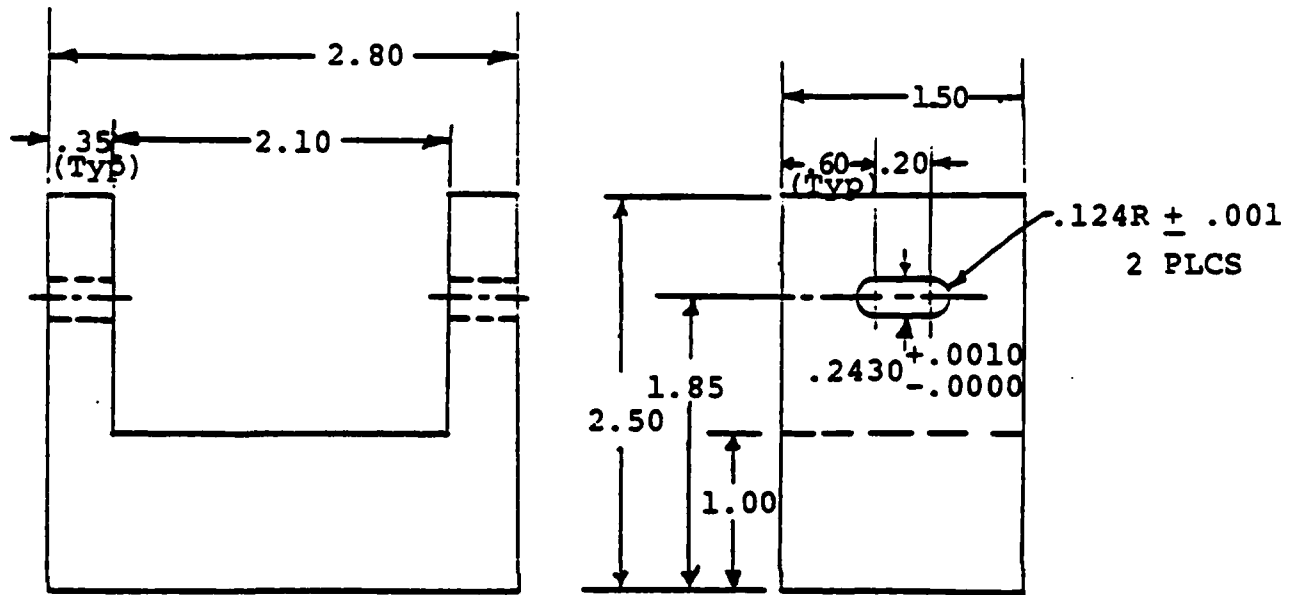

Figure 3. Photograph of Vibrating Beam Test Setup.

Support Block

Mat.-S.S.



Rub Block

7075-T6 or 2024-T4

Tapered Block Cuts

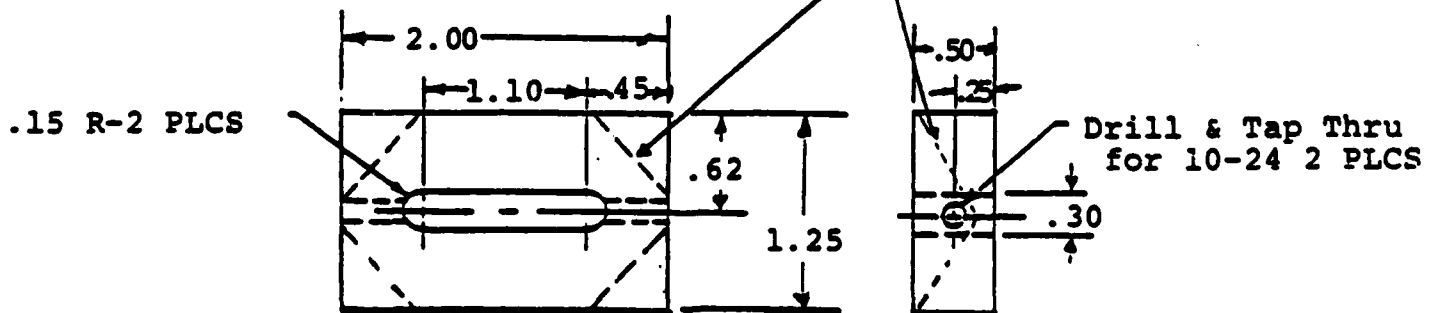

Figure 4. Support Block and Rectangular and Tapered Rub Blocks.

agreement. The curved platform beam and curved surface rub block are shown in Figures 5 and 6, respectively. Figures 7 and 8 show the two beam types and 3 rub block types used in tests.

The data collected from these three test setups, i.e. the rectangular, tapered, and curved rub block test setups, is presented and discussed later in Section 5.

The instrumentation system used to collect experimental data from the vibrating beam test setups is shown schematically in Figure 9. The beam is driven in forced vibration by an electromagnetic exciter acting on a small steel disk glued to the free end of the beam. The electromagnetic exciter is powered by an oscillator sine wave output signal acting through a power amplifier. Beam response is monitored by a miniature accelerometer installed near the free end of the beam. Both the beam maximum acceleration response and the modal damping (half power point bandwidth method) can be measured during slow frequency sweeps with constant excitation force applied. This data can be obtained for various normal loading conditions of the friction surface, from unloaded to lockup, and for various conditions of lubrication of the simulated platform and friction damper surfaces.

The usual set of data that has been recorded consists of a series of frequency sweeps from 50 to 500 Hz for a given beam and rub block surface condition, each sweep having been made with a different normal load applied to the rub block. The same excitation force and accelerometer circuit sensitivity was used during the recording of all the data. The data set was recorded on the X-Y plotter, as shown in Figure 10. As shown in this figure, two resonance peaks occur near the free beam resonances for very light normal load on the friction surfaces. As the normal load increases for successive sweeps, the amplitude decreases and the resonance frequency increases for the first bending mode vibration. Amplitude increases again as the lockup condition is approached until lockup occurs during the No. 16 sweep for this test condition at a normal load of 0.406 lb

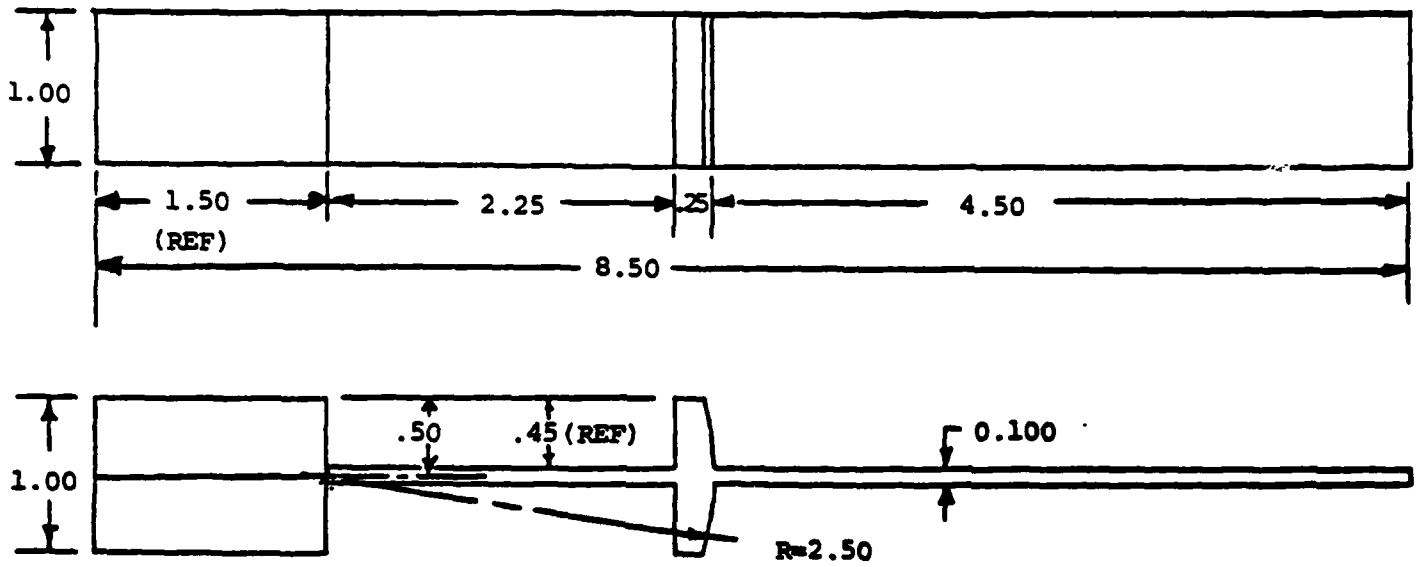

Figure 5. Curved Platform Beam

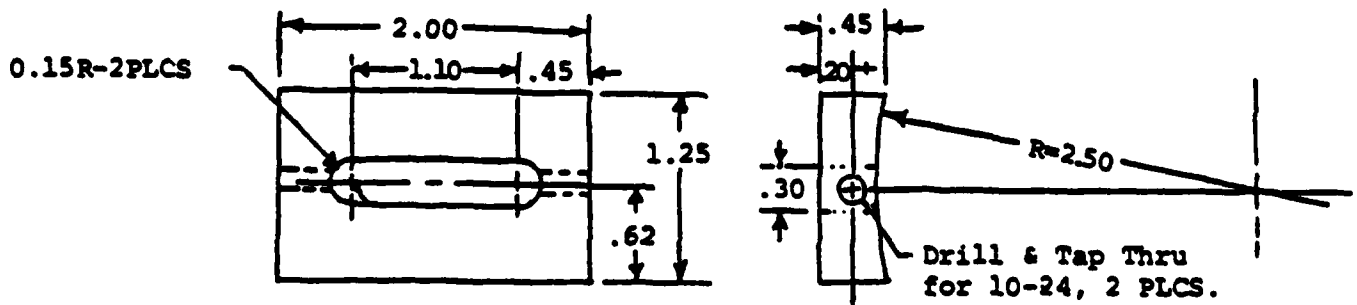

Figure 6. Curved Surface Rub Block

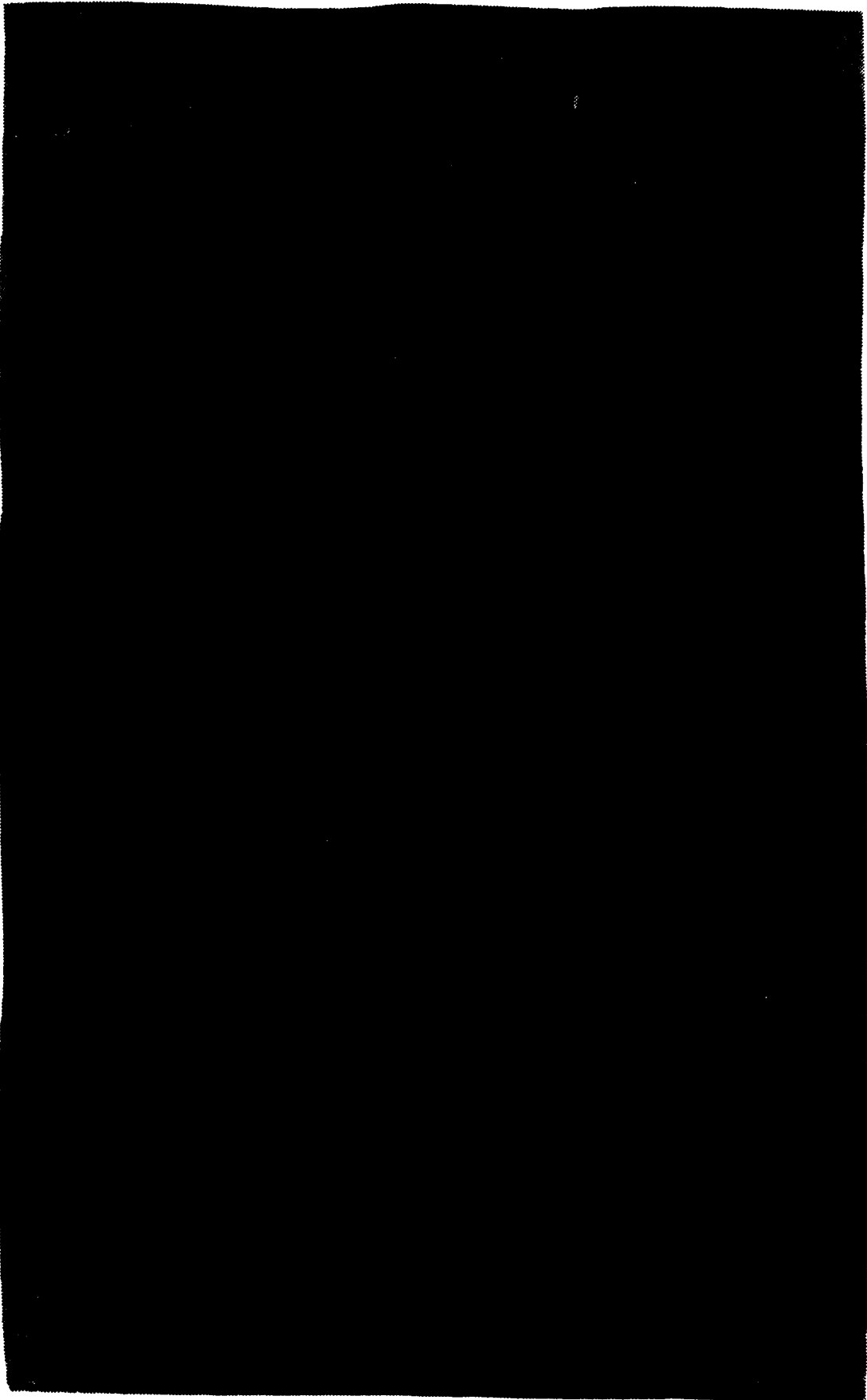

Figure 7. Beams with Flat Surface (left) and Curved Surface Platforms.



**Figure 8. Rectangular, Tapered, and Curved Surface Rub Blocks.**

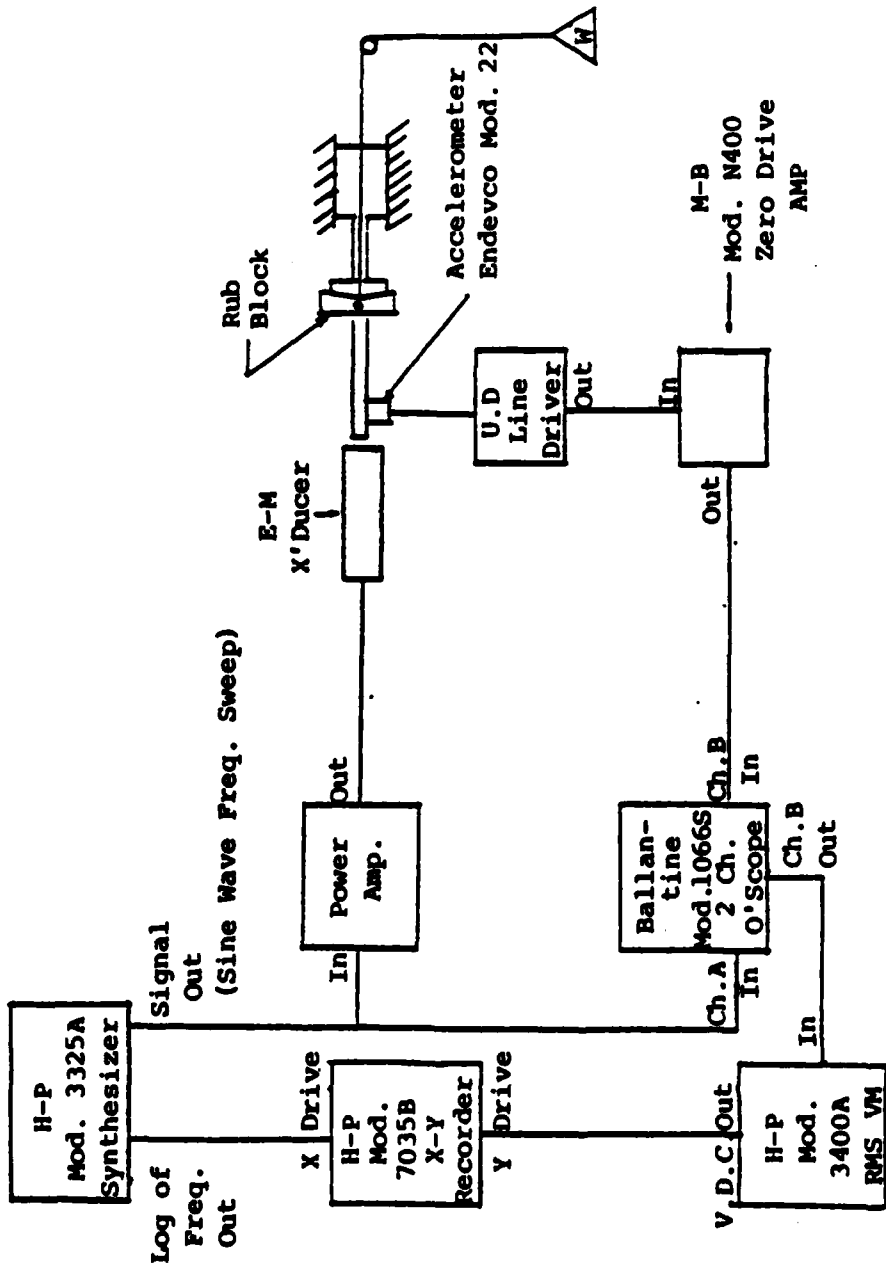
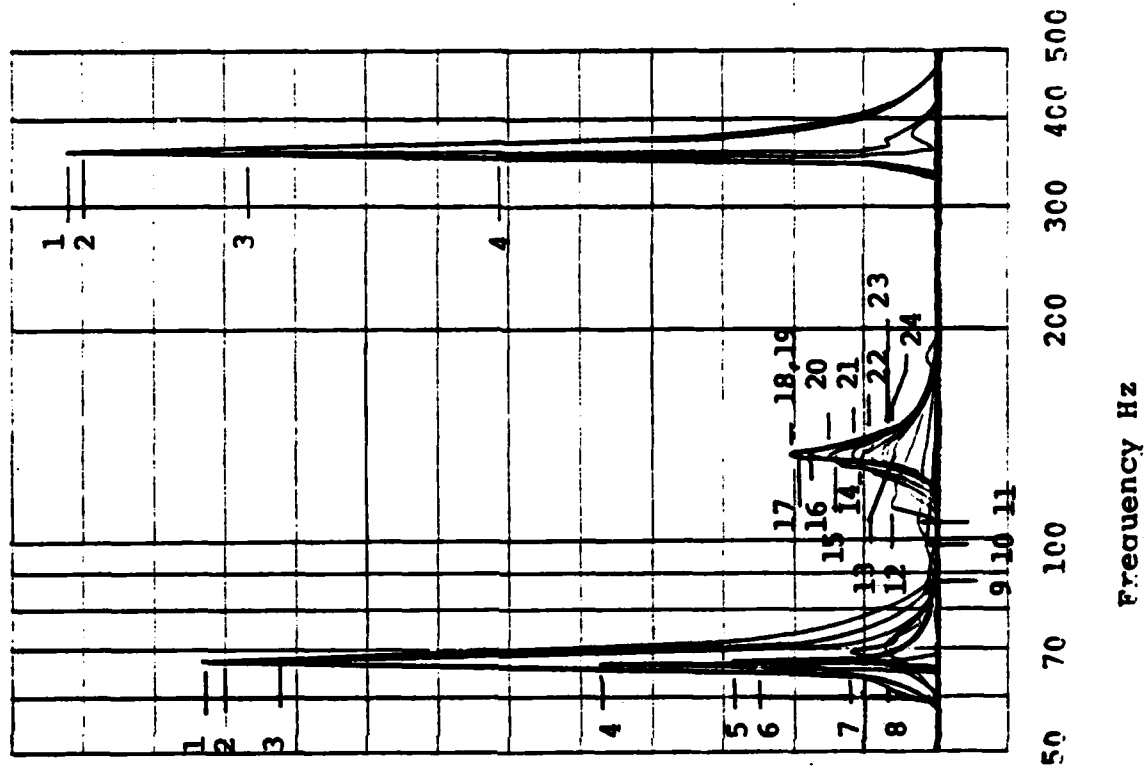

Figure 9. Vibrating Beam Instrumentation System

Curved Block, Dry



NORMAL FORCE APPLICATION SCHEDULE

Point	Weight (lb.)
1	0
2	.004
3	.009
4	.012
5	.017
6	.021
7	.034
8	.048
9	.062
10	.075
11	.088
12	.011
13	.144
14	.231
15	.319
16	.406
17	.493
18	.581
19	.668
20	.784
21	1.038
22	1.170
23	1.583
24	1.905

Figure 10. Typical Set of Frequency Sweeps for One Test Condition.

on the friction surfaces. The lockup resonance represents the first bending mode frequency of the section of the test beam outboard of the platform. The remaining data sets are presented in Section 5.

Half power bandwidth measurements of the loss factor ( $\eta$ ) were made for the first three bending modes of the free beam. The values obtained were:

$$\begin{aligned}\eta_1 &= 0.0028 @ 68 \text{ Hz;} \\ \eta_2 &= 0.0015 @ 368 \text{ Hz;} \\ \eta_3 &= 0.0008 @ 993 \text{ Hz.}\end{aligned}$$

These loss factor values represent hysteretic damping in the beam material augmented by a small amount of air damping and possibly some very small amount of damping occurring at the fixed end clamp. Aluminum material hysteretic damping is of the order of .0001.

Mode shape data was taken on a Hewlett-Packard Model 5451B Fourier Analyzer for the curved platform beam. The mode shapes for the first three bending modes are shown in Figure 11. The data was taken using the impact hammer method. It can be seen that platform motion occurs during all these bending deflections.

### 3. COEFFICIENT OF FRICTION EVALUATIONS

A very simple mechanism was fabricated to determine the coefficient of friction for aluminum surfaces, bare and with various lubricating films on the surfaces. The mechanism consists of a two-inch square aluminum block sliding on a flat aluminum plate. The block is fixed by attaching it with a wire to a miniature load cell which was fabricated and calibrated by UDRI. The plate is slid under the block manually in a horizontal direction parallel to the block-to-load cell attachment wire. Normal load force on the friction surface is varied

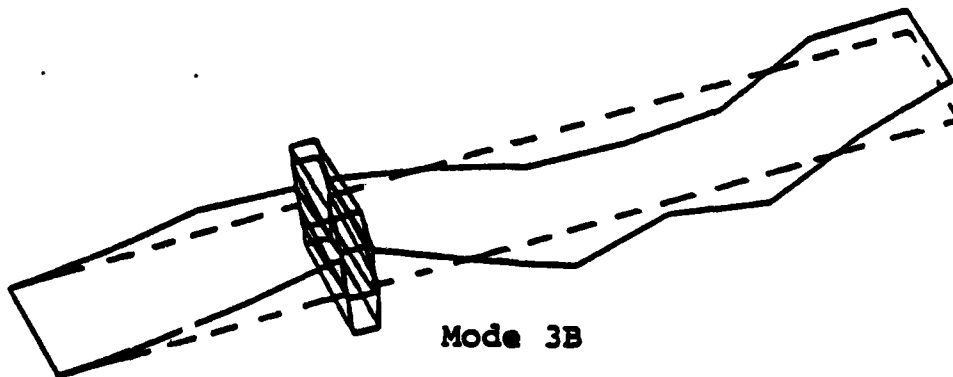
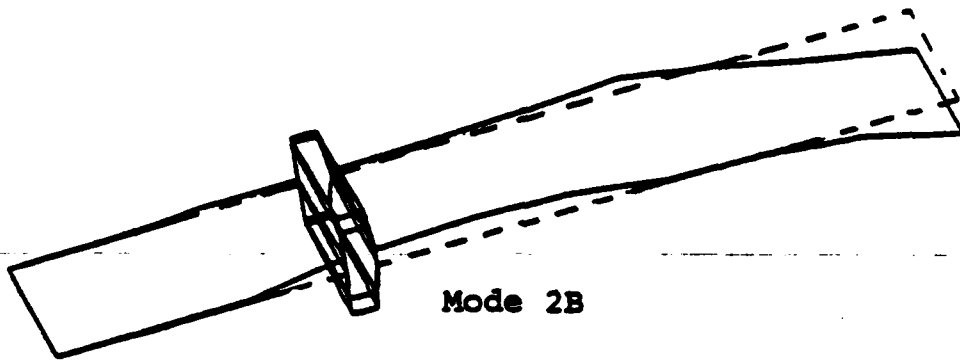
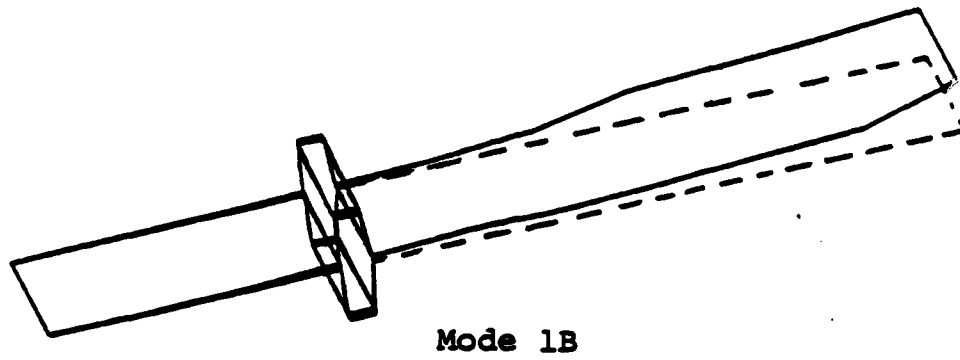

Figure 11. Modal Test Data From Impact Test.

by placing weights on top of the test block. Friction force is recorded on a strip chart recorder as the plate is slid under the test block with various normal loads and at various sliding speeds. A sketch of the apparatus is shown in Figure 12.

The test instrumentation is shown schematically in Figure 13. It consisted of a strain bridge balance and differential amplifier driving an X-Y recorder in the Y direction with a ramp function corresponding to elapsed time driving the recorder in the X direction. The load cell readings also could be monitored by a digital volt meter (DVM). The load cell was calibrated statically with deadweights and a standard parallel resistor calibration step was used to relate the test data to the calibrated circuit sensitivity.

A set of test data, recorded with Teflon backed tape installed to the test block and slide plate mating surfaces, is shown in Figure 14. Successive data points represent approximately six inch slides of the plate under the test block as increasingly heavy weights are placed on top of the block. The maximum weight represents a pressure of about 2.25 psi over the surface of the two inch square block. This range of pressures is representative of those used to date in the vibrating beam tests. The average deflection reading for each slide was faired through the data record by hand and the friction force in pounds was calculated using the calibration step deflection reading. Division of the friction force (F) by the applied weight (N) then yields the coefficient of friction for that slide from the relationship:  $F = \mu N$  or  $\mu = F/N$ . The sixteen values of  $\mu$  thus determined then were averaged to give the average coefficient of friction ( $\bar{\mu}$ ) for the data set taken with a particular surface condition on the mating test block and slide plate surfaces.

The average coefficient of friction was evaluated for seven different surface conditions of the rolled aluminum plate test block and slide plate. Those seven surface conditions were:

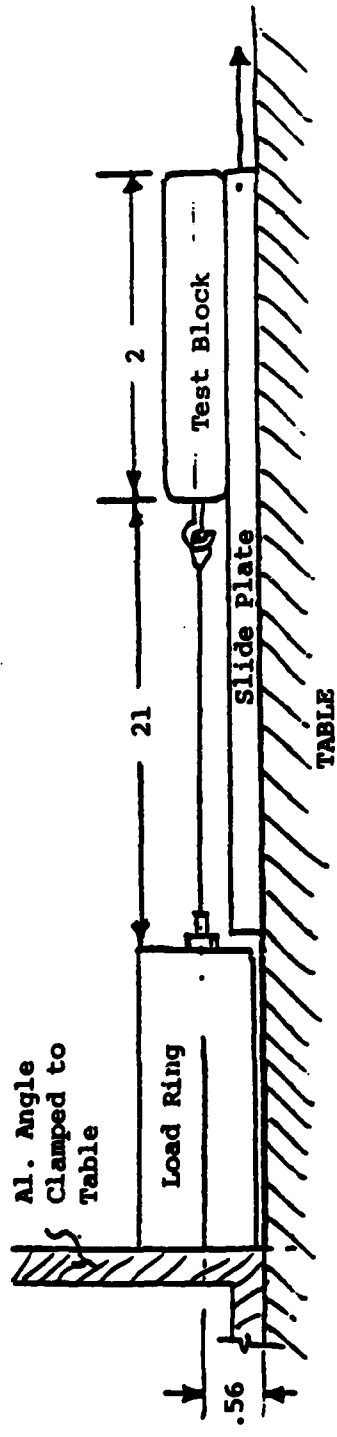

Figure 12. Coefficient of Friction ( $\mu$ ) Evaluation Test Setup.

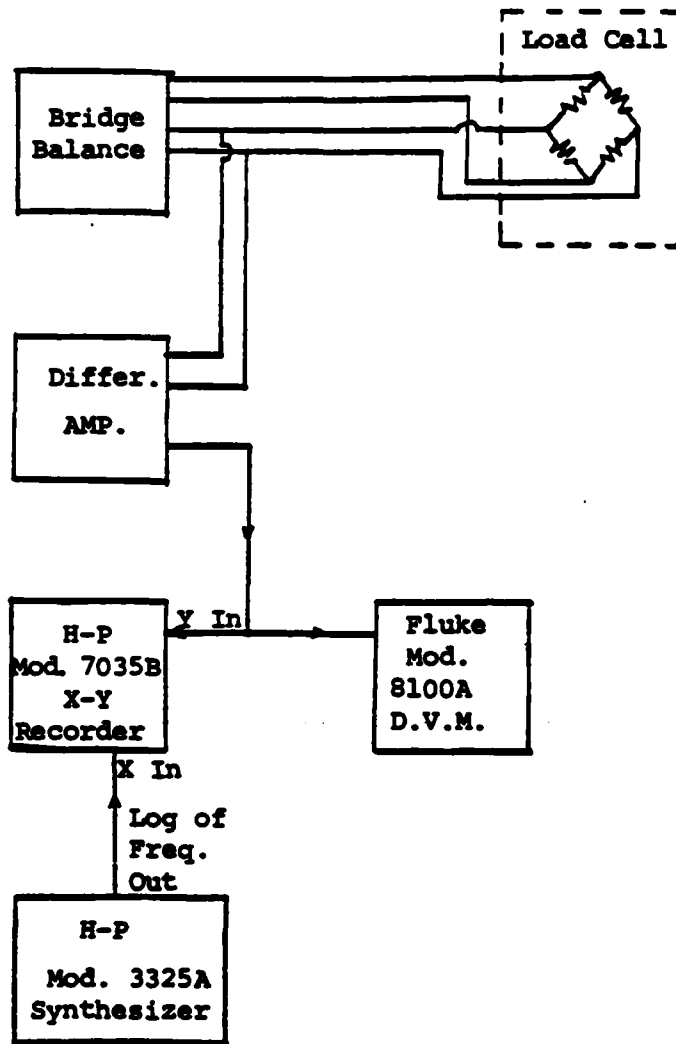

Figure 13. Coefficient of Friction Instrumentation Setup

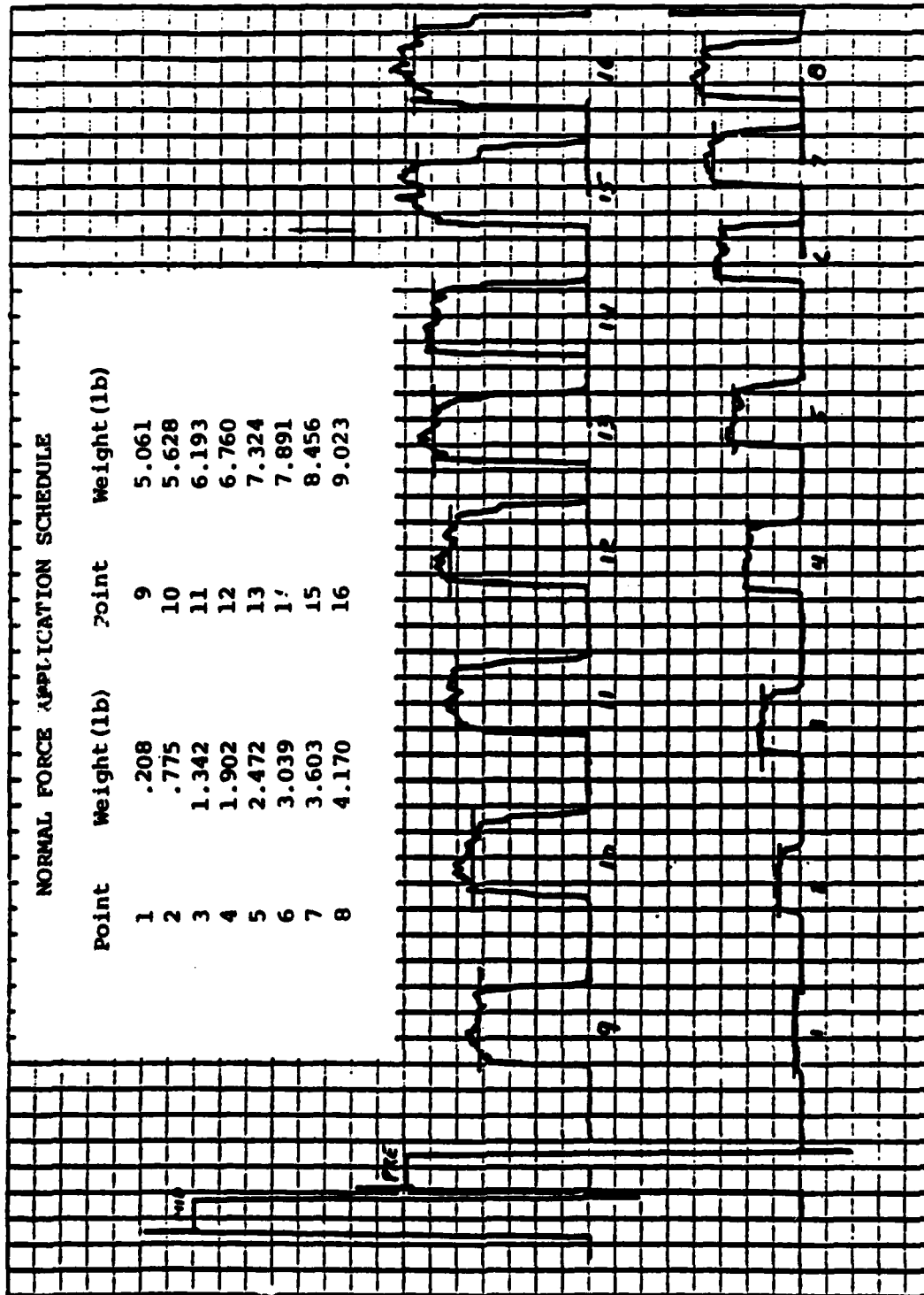

Figure 14. Coefficient of Friction Evaluation Data Chart

dry aluminum in the "as rolled" condition; with a coating of teflon particles in an organic binder; with teflon backed tape; with a dry molybdenum disulfide powder coating; with a water film; with a wet graphite suspension in light mineral oil; and with a light, dry graphite coating after the mineral oil evaporated. In most cases two or three data sets were taken for each surface condition and the results were averaged. The results of all the testing are shown in Table 1. Bare aluminum surfaces (average  $\mu$  of 0.24) or teflon tape coated surfaces (average  $\mu$  of 0.19) have been used in all the vibrating beam friction damping tests conducted thus far.

TABLE 1  
AVERAGE COEFFICIENTS OF FRICTION ( $\bar{\mu}$ )  
FOR ALUMINUM BEARING SURFACES

<u>LUBRICANT</u>	<u><math>\bar{\mu}</math></u>
DRY ALUMINUM, AS ROLLED	.241
TEFLON PARTICLES IN ORGANIC BINDER	.178
TEFLON BACK TAPE	.190
MOLYBDENUM DISULFIDE POWDER	.242
WATER FILM	.187
GRAPHITE/OIL SUSPENSION (WET)	.040
GRAPHITE/OIL SUSPENSION (DRY)	.233

#### 4. ANALYSIS OF BEAM RESPONSE BY THE LUMPED MASS METHOD

A computer program has been implemented on the University's VAX 11/780 computer system which predicts the response amplitude and phase angle for a multibladed disk system with the blades driven at the tip and with friction dampers at the platform masses. This program assumes the blades are fixed in the disk, or so firmly clamped that energy losses at the interface are negligible and are included in the blade material loss factor. In essence, each blade is assumed to be a lumped mass beam consisting of two

modal masses supported by two massless cantilevered flexural springs, with friction damping applied at the inboard (platform) mass. The sketch of the system (Figure 15) shows that the blade system is very nearly the analog of the vibrating beam test arrangement, the differences being that most of the test beam masses are distributed in the flexural springs and the rub block is of finite mass and pin supported rather than being an infinite fixed mass, which is the way it is treated in the computer analysis. The equation of motion was represented by the equations (References 12 to 20):

$$m_1 \ddot{x}_1 + k_1(x_1 - x_2) + \frac{k_1 \eta}{\omega} (\dot{x}_1 - \dot{x}_2) = \underline{S} \cos(\omega t + \delta)$$

$$m_2 \ddot{x}_2 + k_1(x_2 - x_1) + k_2 x_2 + \frac{k_1 \eta}{\omega} (\dot{x}_2 - \dot{x}_1) + \frac{k_2 \eta}{\omega} \dot{x}_2 + \mu N_N \text{Sign } \dot{x}_2 = 0$$

where  $m_1$ ,  $m_2$  are the modal masses,  $k_1$ ,  $k_2$  are the modal stiffnesses,  $\eta$  is the blade material loss factor,  $\mu$  is the coefficient of friction,  $N_N$  is the normal force,  $\underline{S}$ ,  $\omega$ , and  $\delta$  are the amplitude, frequency, and phase angle of the exciting force. The response of the blade will then be

$$x_1(t) = D \cos(\omega t + \gamma)$$

$$x_2(t) = A \cos(\omega t + \alpha)$$

where  $D$  and  $A$  are amplitudes and  $\alpha$ ,  $\gamma$  are phase angles of the response. For calculation purposes the method of harmonic balance is applied with the following simplification for the nonlinear friction term

$$\mu N_N \text{Sign } (\dot{x}_2) = \frac{-4}{\pi} \mu N_N \frac{A}{|A|} \text{Sin}(\omega t + \alpha) \quad .$$

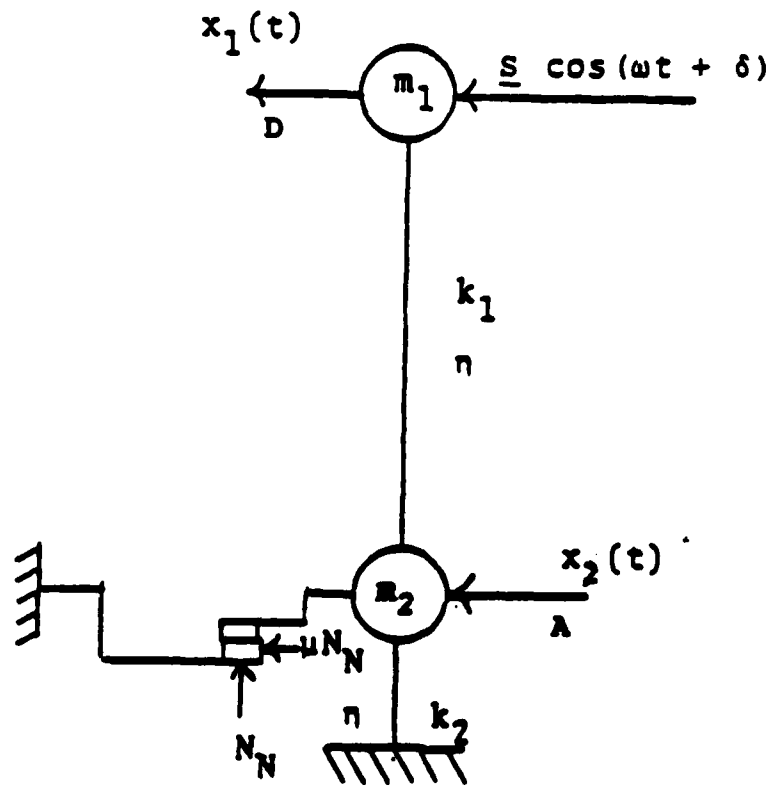

Figure 15. Physical Model of Single-Blade System.

The computer program input parameters for the analytical solution are: the two modal masses ( $m_1, m_2$ ); the two flexural spring stiffnesses ( $k_1, k_2$ ); the cantilevered beam loss factor ( $\eta$ ); the coefficient of friction ( $\mu$ ); the friction surface normal force ( $N_N$ ); and the amplitude and phase of the forcing function ( $S, \delta$ ). The program solves the differential equations of motion of the beam using an iterative numerical process, the output data set consisting of the amplitude and phase angle of the outboard ( $D, \gamma$ ) and inboard ( $A, \alpha$ ) masses. The number of iterations used in the solution and the degree of exactness of the solution are also reported. Limits can be placed on the number of iterations allowed and on the degree of exactness required to reduce processing costs. Another set of input parameters is the frequency range to be covered and the size of the intervals within that frequency range at which solutions are to be computed, i.e. a frequency sweep is made with solutions given at equal increments of frequency within the sweep range. This data set is similar to our laboratory test data set except that the frequency sweep is incremental rather than continuous. In addition, a graphics package has been added which allows multiple frequency sweeps to be plotted on a single figure just as in our multiple record data sets on the laboratory X-Y plotter. Pertinent analytical computer program output data plots are presented and discussed in Section 5.

The input data parameters used in the computer program runs are, first of all, a loss factor ( $\eta$ ) of 0.002 as determined from the free beam tests, and secondly, coefficients of friction ( $\mu$ ) of 0.24 and 0.19 as determined from the sliding friction tests. The modal constants ( $m_1, m_2, k_1, k_2$ ) can be derived by a system of equations based on the experimentally determined first two bending mode resonances of the beam and the first resonance mode of the outboard section of the beam when the platform is fixed. The system of three resonance equations containing the four modal unknowns yields values for three unknowns in terms of the fourth unknown. Any one of the four can be estimated, then the values of the other three are determined. A mistake in the first estimate causes an error in the two amplitude outputs. It does not affect

the frequency response, phasing, or relative amplitude of the outboard mass displacement to the inboard mass displacement. The modal parameters used for the analytical computer program data presented were derived using resonance frequencies of 68, 368, and 160 Hz for  $f_1$ ,  $f_2$ , and  $f_3$ , respectively, and the following equations derived from the resonance conditions:

$$k_1 = (2\pi f_3)^2 m_1 = 1.01 \times 10^6 m_1$$

$$k_2 = \frac{(2\pi f_1 f_2 f_3)^2}{(f_2^2 - f_3^2)(f_3^2 - f_1^2)} m_1 = 2.73 \times 10^5 m_1$$

$$m_2 = \frac{f_3^4}{(f_2^2 - f_3^2)(f_3^2 - f_1^2)} m_1 = 0.286 m_1$$

The value of  $m_1$  was estimated to be 0.06 lb. The other values then became  $m_2 = 0.0172$  lb.,  $k_1 = 60600$  lb/in., and  $k_2 = 16400$  lb./in.

The analytical computer program also has an option for multiblade solutions. That option has not been exercised during this effort and will not be discussed here. It is hoped to get into two-blade with interblade friction damping testing and theoretical analysis in the future.

## 5. PRESENTATION AND DISCUSSION OF RESULTS

Six sets of experimental data are presented for laboratory blade to disk friction damping tests in Figures 16 through 21. Figures 16 and 17 are sine wave frequency sweeps for the straight platform beam with the rectangular prism rub block (see Figure 1 and 4), first with bare aluminum friction surfaces ( $\mu = 0.24$ ), then with teflon tape covered friction surfaces ( $\mu = 0.19$ ). Figures 18 and 19 are for the straight platform beam and the tapered rub block (see Figure 1 and 4), first bare, then tape covered. Figures 20 and 21 are for the curved platform beam (see Figure 5 and 6), bare then tape covered.

Each of these graphs shows a succession of sine wave frequency sweeps imposed on the tip of the blade, first with no rub block contact to the platform, then with the rub block to platform normal force increased on each successive sweep. The frequency range covered by the sweeps is from 40 to 200 Hz and the normal force loading increments covered the range from 0 to 471 grams or 0 to 1.038 pounds. The vibrating beam tests are summarized below in Table 2.

TABLE 2  
VIBRATING BEAM TEST SUMMARY

<u>FIG. NO.</u>	<u>PLATFORM SURFACE</u>	<u>RUB BLOCK CONFIG.</u>	<u>COEFF. OF FRICTION</u>	<u>N<sub>N</sub> FOR OPT. DAMPING</u>	<u>N<sub>N</sub> FOR LOCK-UP</u>
16	FLAT	RECT. PRISM	0.24	0.021 lb. (9.5 gm)	0.784 lb. (356 gm)
17	FLAT	RECT. PRISM	0.19	0.048 lb. (22 gm)	1.038 lb. (471 gm)
18	FLAT	TAPERED	0.24	0.021 lb. (9.5 gm)	0.784 lb. (356 gm)
19	FLAT	TAPERED	0.19	0.034 lb. (15 gm)	0.581 lb. (263.5 gm)
20	CURVED	CURVED	0.24	0.048 lb. (22 gm)	0.784 lb. (356 gm)
21	CURVED	CURVED	0.19	0.062 lb. (28 gm)	0.784 lb. (356 gm)

The data shown in these six figures is qualitative data in that the sensitivity of the accelerometer instrumentation circuit and the exact value of the excitation force were not calibrated. However, all six data sets were recorded with exactly the same accelerometer sensitivity and with the same electrical drive signal imposed on the excitation transducer. It was necessary to change the setup to install the curved platform

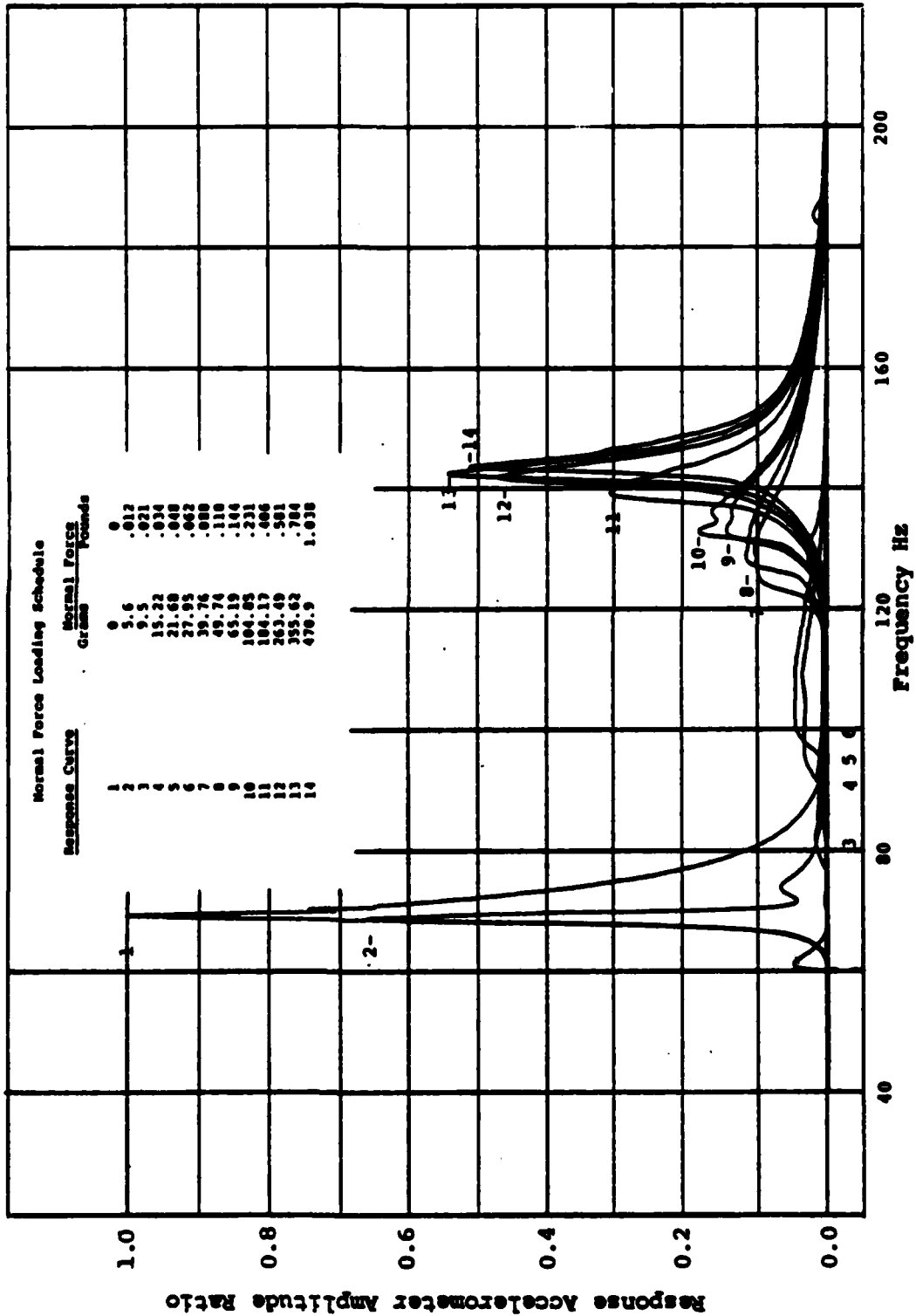

Figure 16. Vibration Response of Straight Platform Beam with Rectangular Rub Block -  $\mu=0.24$ .

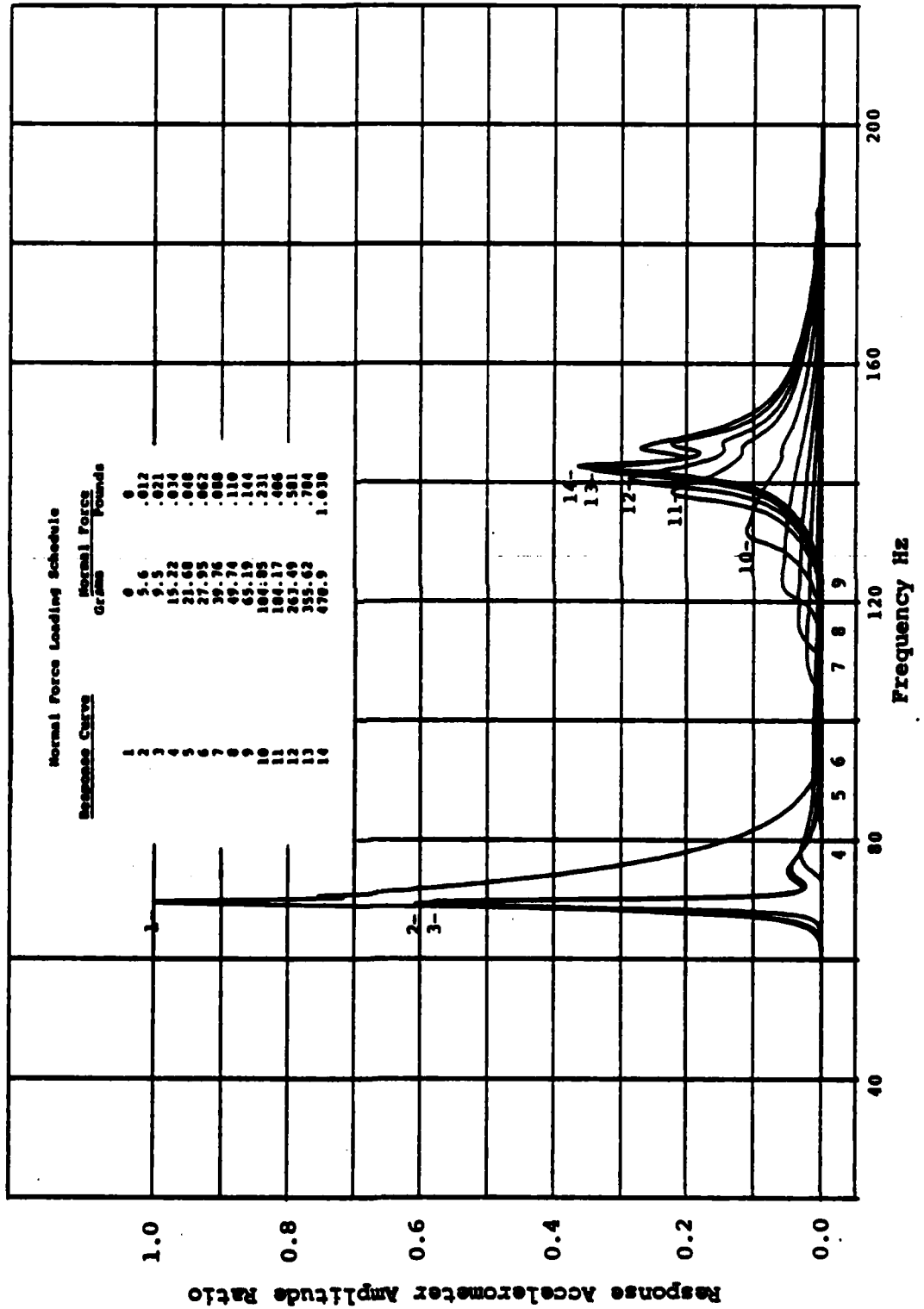

Figure 17. Vibration Response of Straight Platform Beam with Rectangular Rub Block -  $\mu=0.19$ .

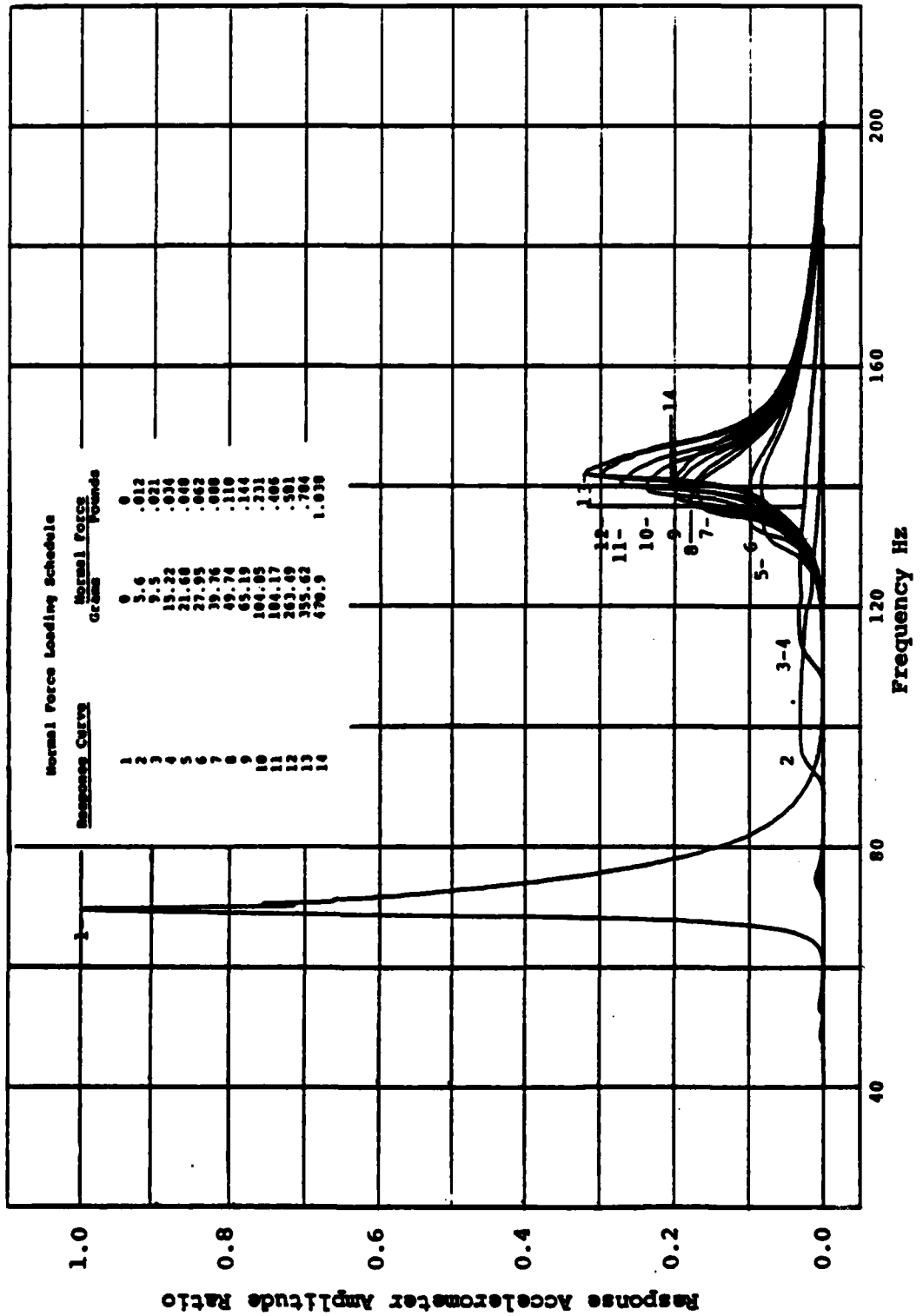

Figure 18. Vibration Response of Straight Platform Beam with Tapered Rub Block -  $\mu=0.24$ .

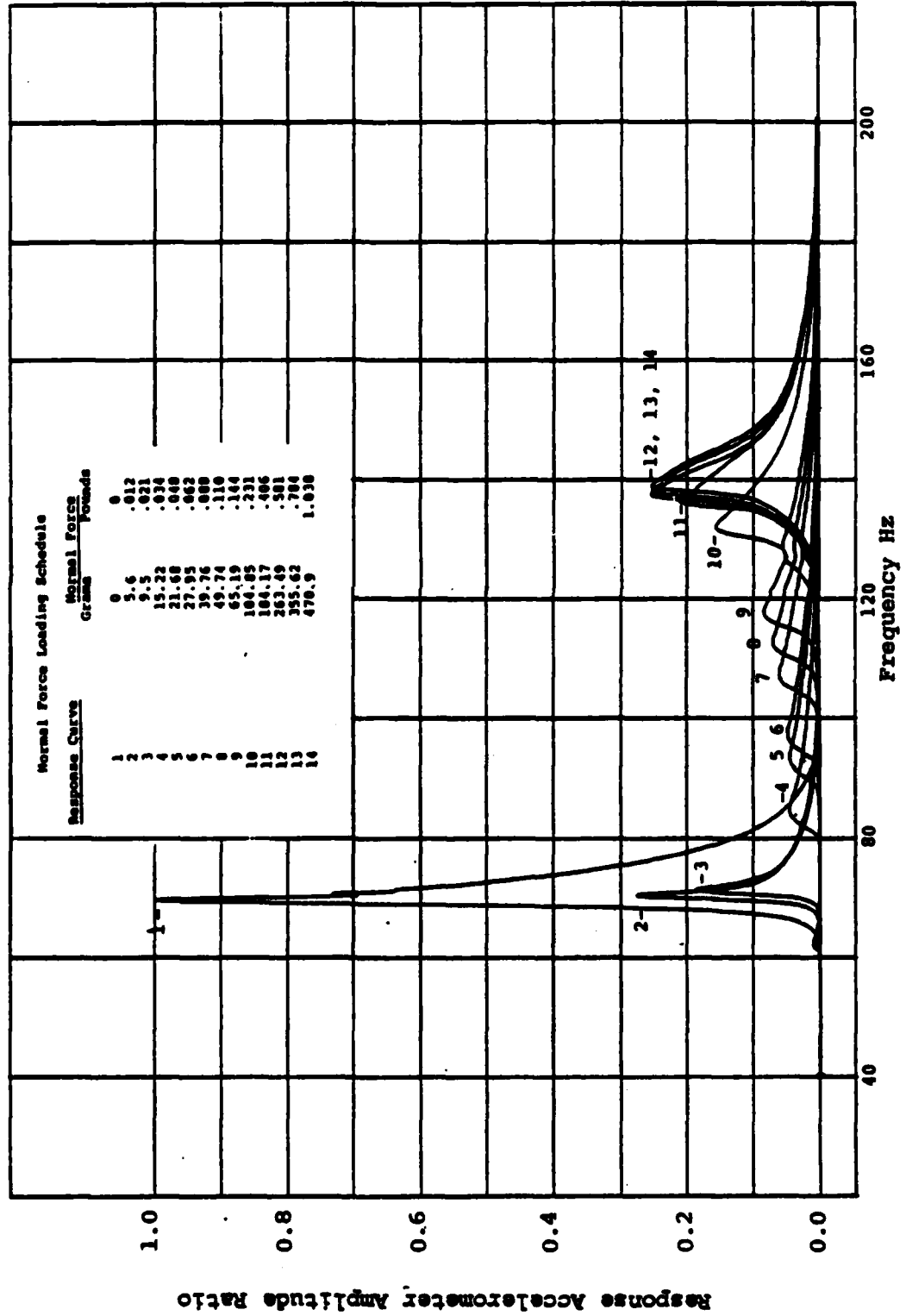

Figure 19. Vibration Response of Straight Platform Beam with Tapered Rub Block -  $\mu=0.19$ .

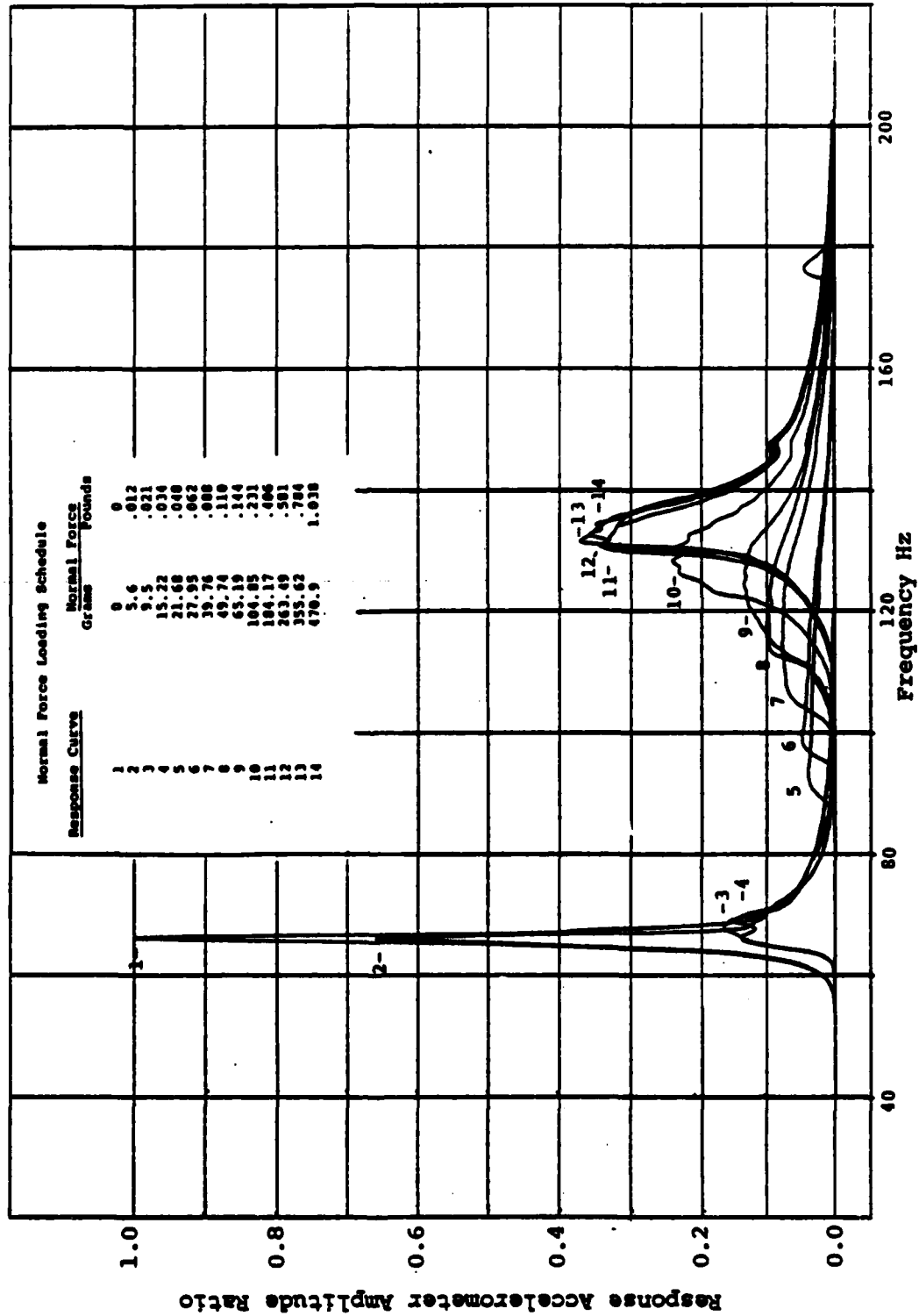

Figure 20. Vibration Response of Curved Platform Beam with Curved Surface Rub Block -  $\mu=0.24$ .

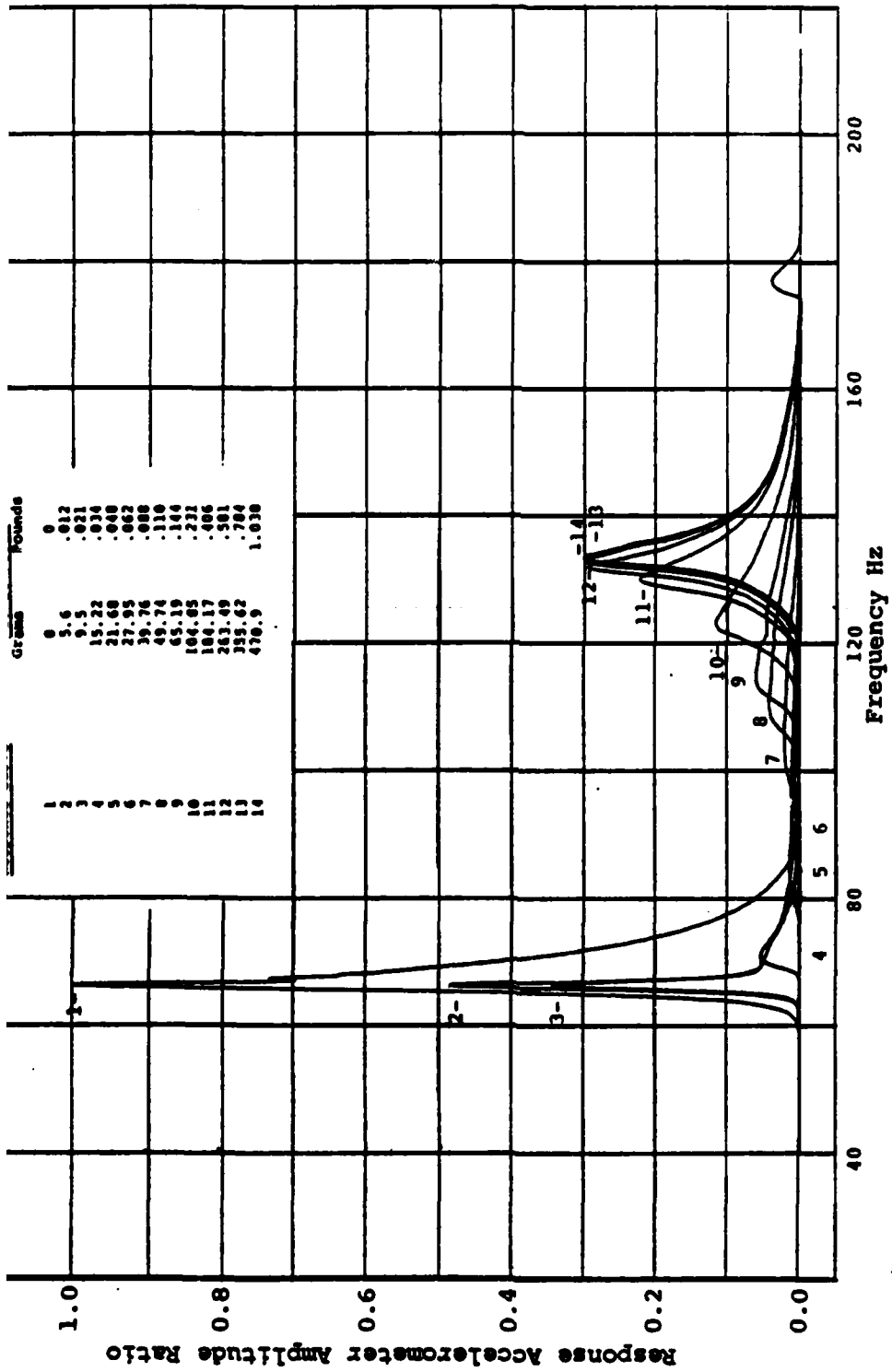

Figure 21. Vibration Response of Curved Platform Beam with Curved Surface Rub Block -  $\mu=0.19$ .

and curved rub block to acquire the data sets shown in  
es 20 and 21. There may have been some slight differences  
e location of the accelerometer, excitation disk, and  
transducer for these last two data sets, but geometric  
rences were minimized to the extent that was possible and  
ata was normalized at the first bending mode response level.  
urved platform beam has slightly different resonance  
encies than the straight platform beam, but the differences  
ess than five percent.

The similarities in the six sets of data are great. They  
how that maximum damping and minimum blade response occur  
ry low normal force loading of the friction surface for this  
configuration. Blade response is very low for this condition,  
ing as little as one percent of the response of the unrestricted

As the normal force loading on the rub block is increased,  
aint is imposed on the blade platform. The blade begins to  
ct as a cantilever from the restrained platform with damping  
asing and response therefore increasing as more and more  
aint is imposed on the platform by the increasing normal force  
ng. The response reaches a maximum, at the first mode resonance  
ency of the beam section outboard of the platform, for normal  
loadings in the range from 0.5 to 1.0 pound (227 to 454 grams)  
he six test conditions shown in these figures. It is assumed  
the platform is fully restrained, or "locked up", at this  
tion with no lateral motion taking place. It is believed  
some slight platform rotation occurs and that this is the  
n that this resonance shifts frequency to about 140 Hz from  
60 Hz resonance that occurs with the platform fully clamped.  
asing the normal force loading beyond the lock-up force does  
roduce an appreciable effect on the beam response.

In addition to the data presented here, a similar set of  
was collected over the frequency range from 50 to 500 Hz,  
lustrated in Figure 10. That data showed that the second  
ng mode vibration response at 368 Hz was reduced to the same  
t as the first bending mode response at 68 Hz by the intro-  
on of friction damping at the platform. The data set for the

frequency range of 40 to 200 Hz was generated for this report because it is more easily interpreted in the range from 65 to 145 Hz, the range in which the friction damping phenomena are illustrated most clearly.

If Figures 16 and 17 are compared the effects can be seen of the lower coefficient of friction obtained by applying teflon backed tape to the mating platform and rub block surfaces. These effects are: first, a slightly higher normal force loading is required to obtain minimum response at the blade tip; and second, a lower blade tip response occurs at the platform lock-up condition, which also requires a higher normal force loading. The first of these effects is due to the reduction of the coefficient of friction ( $\mu$ ) from 0.24 to 0.19, a 21 percent reduction. The second effect is believed to be due to the damping of the teflon backed tapes adhesive layer. Figure 22 illustrates this effect. Frequency sweeps were made at four different conditions using the curved surface beam and rub block. The first sweep recorded the response of the beam with the platform unrestrained. The blade was then clamped across the platform in a heavy parallel jaw machinist vise to obtain the first mode resonance peak of the blade outboard of the platform. The third and fourth sweeps were with no normal force and one pound (454 grams) normal force applied to the rub block which was fastened to the platform with a 0.003-inch layer of Soundcoat MN viscoelastic damping material. This simulated the lock-up condition observed during tests conducted with teflon tape. The responses of the tip to the excitation during the two sweeps with the platform viscoelastically damped were virtually identical indicating that the two thin layers of tape adhesive contributed to the increased damping at or near the platform-disk lock-up condition. The same effects can be seen if the data shown in Figures 18 and 20 are compared with that shown in Figures 19 and 21, respectively. Further reduction of the coefficient of friction by other treatments of the mating friction surfaces would be expected to increase the normal force loading required for minimal response and for lock-up of the platform.

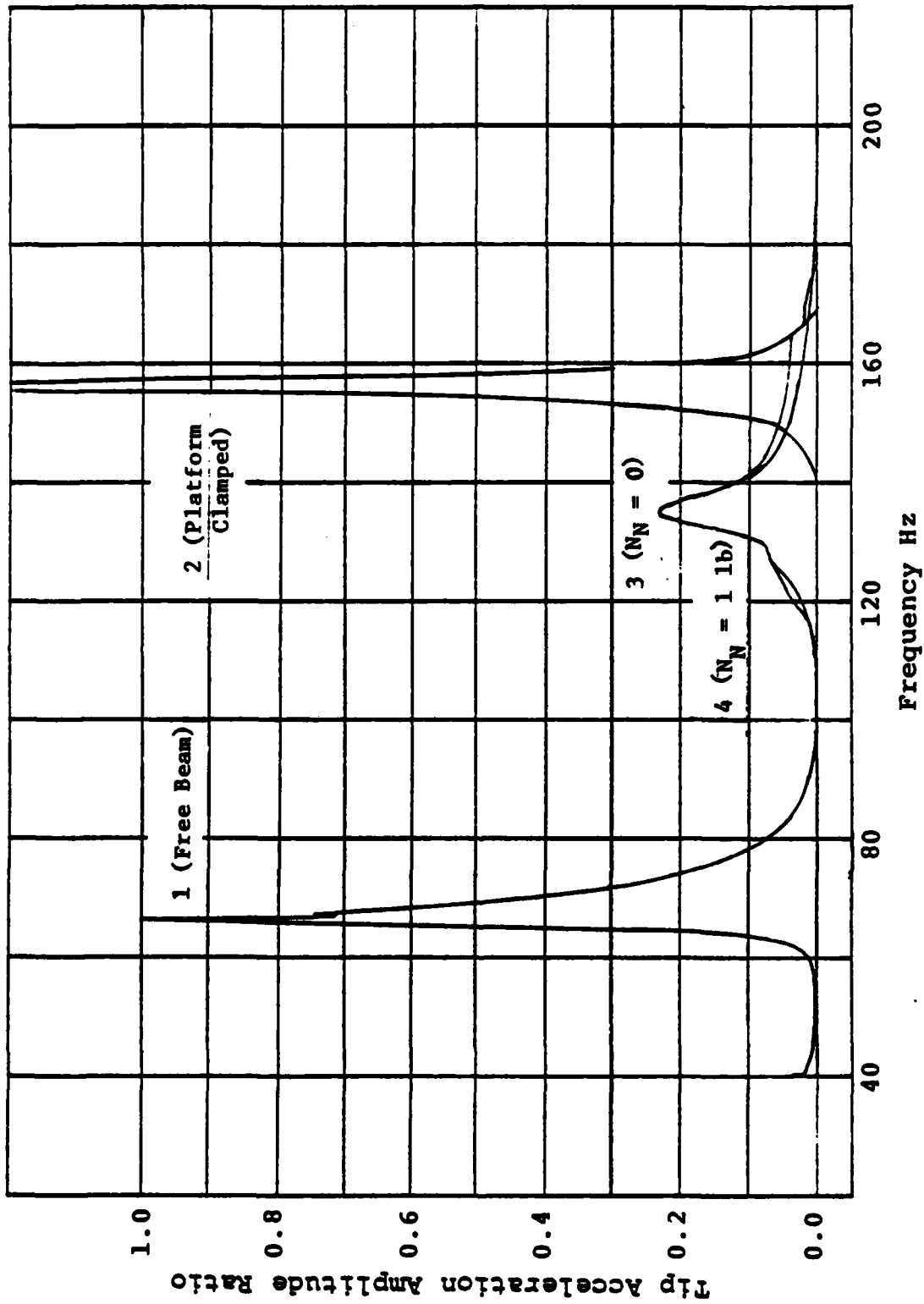

Figure 22. Vibration Response of Curved Platform Beam with Curved Surface Rub Block - Viscoelastic Damping Layer.

Figures 23 through 28 show the results of runs of the lumped mass blade vibration computer program. These figures show frequency sweeps obtained by taking computer solutions at one Hz intervals, over the range from 40 to 200 Hz, for lumped mass blades having the correct mass and stiffness ratios to have first and second bending mode resonances at 68 and 370 Hz and a clamped platform first resonance at 160 Hz. The zero friction damping condition and nine conditions of normal force loading are shown on each of the six figures. Figures 23 and 24 show the results for blades that have a total hysteretic damping, in the blade material and the root clamp, equivalent to a loss factor ( $\eta$ ) of 0.002. Figure 23 shows the results for a coefficient of friction ( $\mu$ ) of 0.24 (for bare aluminum) and Figure 24 for a  $\mu$  of 0.19 (teflon tape covered). If these two figures are compared it can be seen that the minimum response occurs at a lower normal loading force ( $N_N$ ) on the friction surfaces for the higher coefficient of friction data. This is equivalent to the result shown in the experimental data.

Figures 25 and 26 show similar data but with  $\eta$  increased an order of magnitude to 0.02. For Figures 27 and 28  $\eta$  was increased another order of magnitude to 0.2. The data from these latter four figures show the same trends as Figures 23 and 24 but the peaks are depressed and broadened as would be expected by the increased hysteretic damping.

These response curves were calculated for a one pound sine wave excitation force. The data in all six figures show that minimum response of the beam (blade) occurs when the friction damping force ( $\mu x N_N$ ) is equal to or just slightly higher than the excitation force of one pound. They also show that this effect is independent of the hysteretic damping ( $\eta$ ) and of  $\mu$  and  $N_N$  taken separately. This result would seem to have implications for all turbine blade friction damping mechanisms in that the normal force ( $N_N$ ) is usually induced by centrifugal loading and is often very much greater than the excitation force. The coefficient of friction ( $\mu$ ) should be minimized then to obtain optimal friction damping and the normal force should be minimized as much as possible.

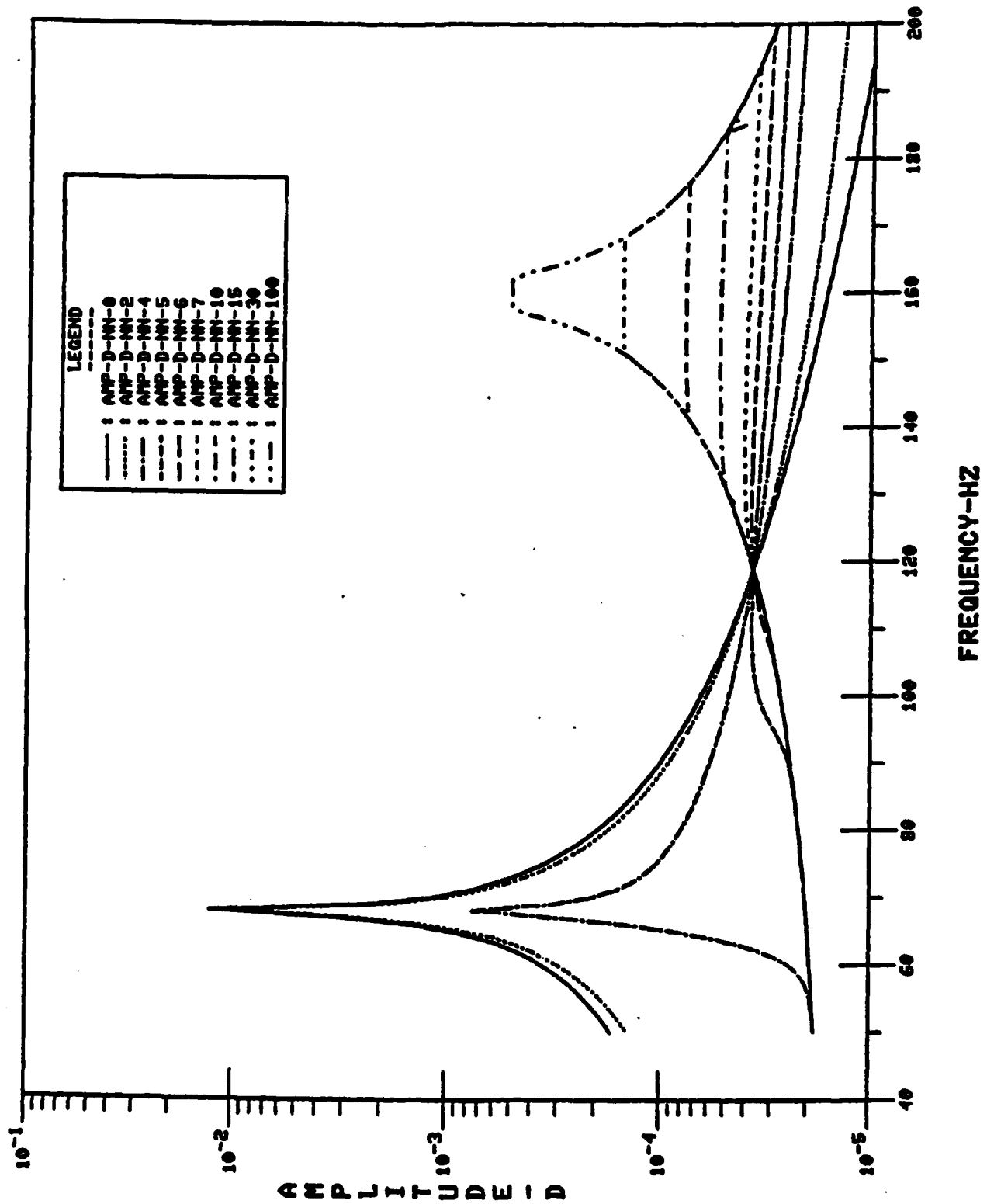

Figure 23. Computed Vibration Response of Lumped Mass Beam with  $\eta=0.002$ ,  $\mu=0.24$ .

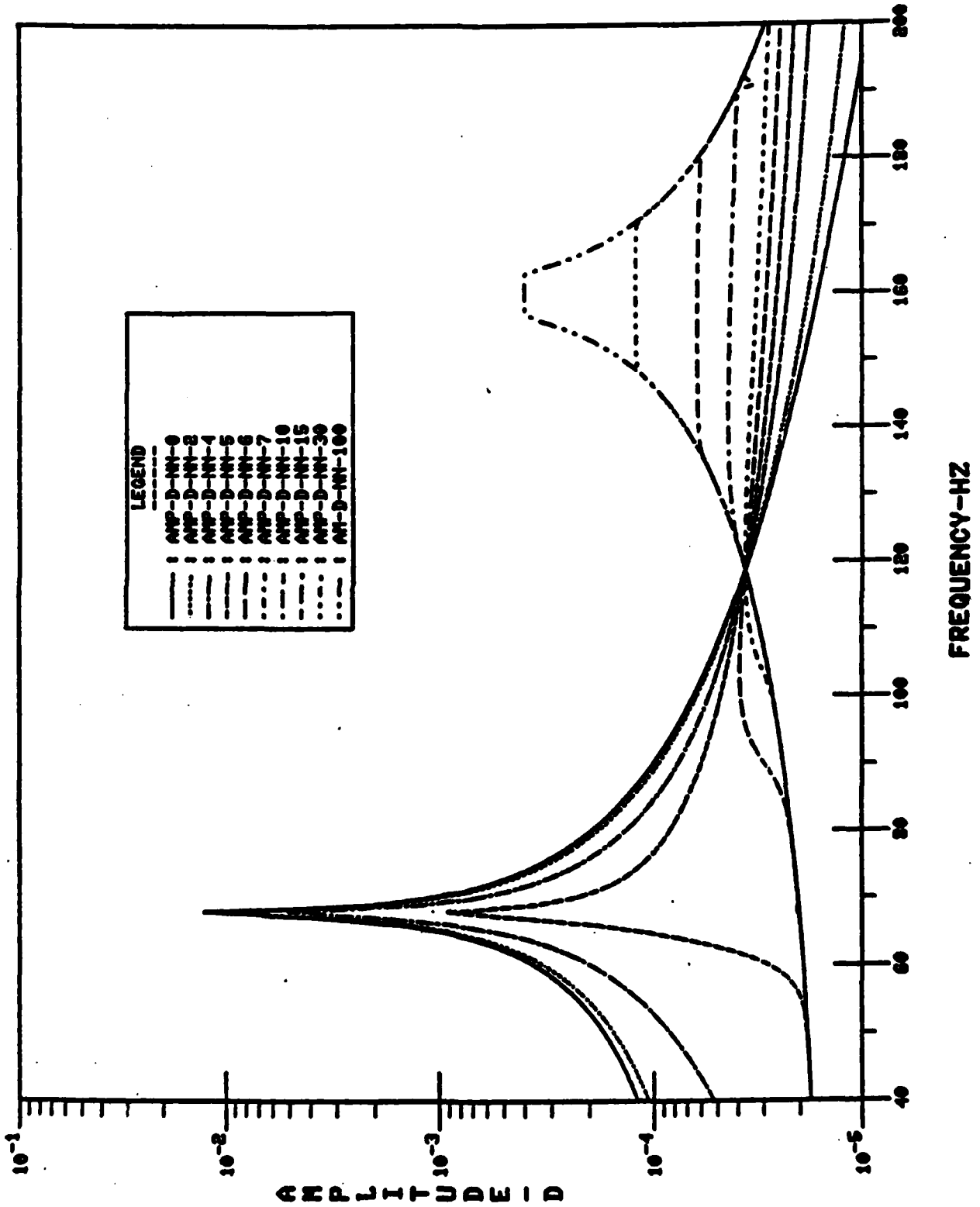

Figure 24 . Computed Vibration Response of Lumped Mass Beam with  $\eta=0.002$ ,  $\mu=0.19$ .

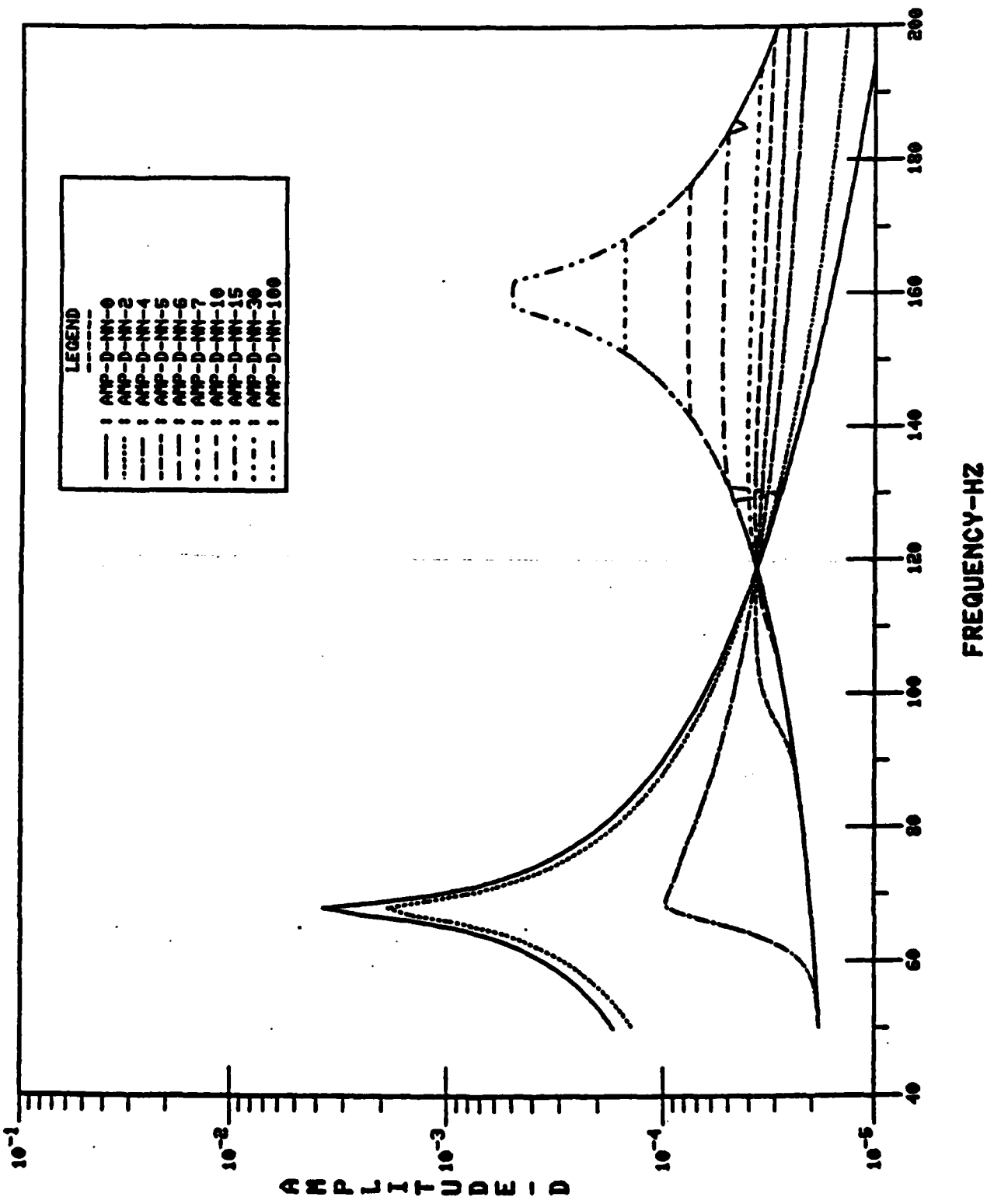

Figure 25. Computed Vibration Response of Lumped Mass Beam with  $\eta=0.02$ ,  $\mu=0.24$ .

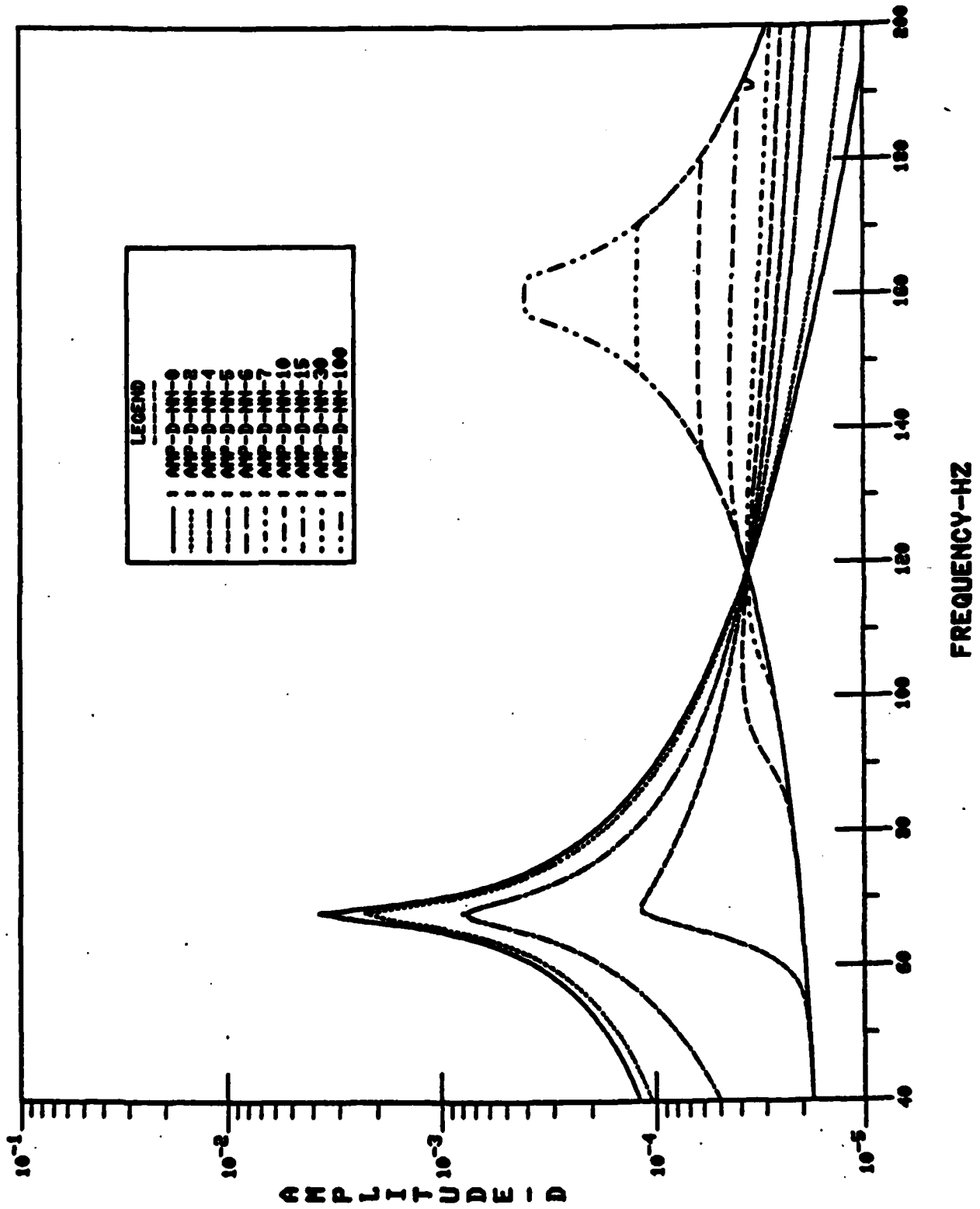

Figure 26. Computed Vibration Response of Lumped Mass Beam with  $\eta=0.02$ ,  $\mu=0.19$ .

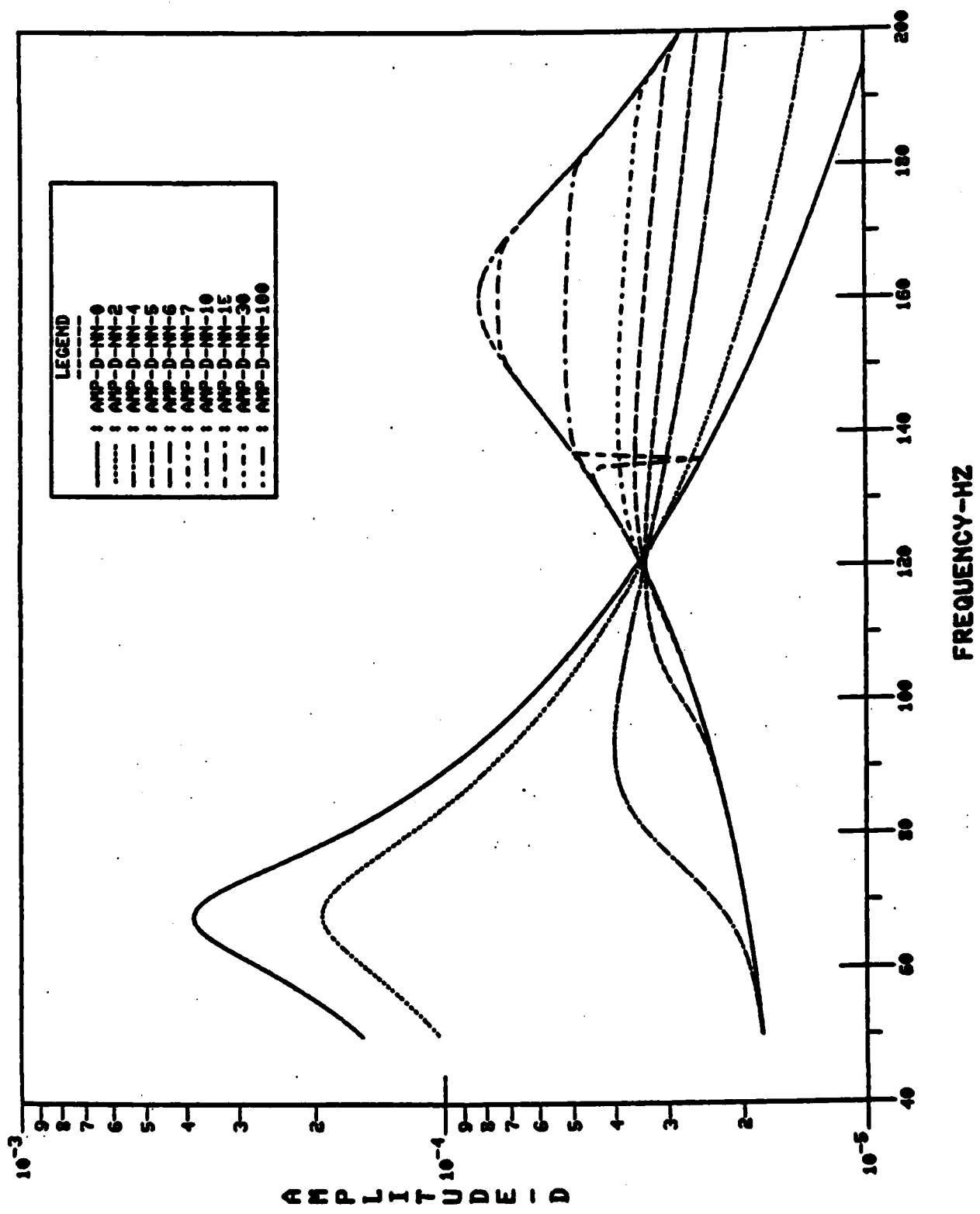

Figure 27. Computed Vibration Response of Lumped Mass Beam with  $\eta=0.2$ ,  $\mu=0.24$ .

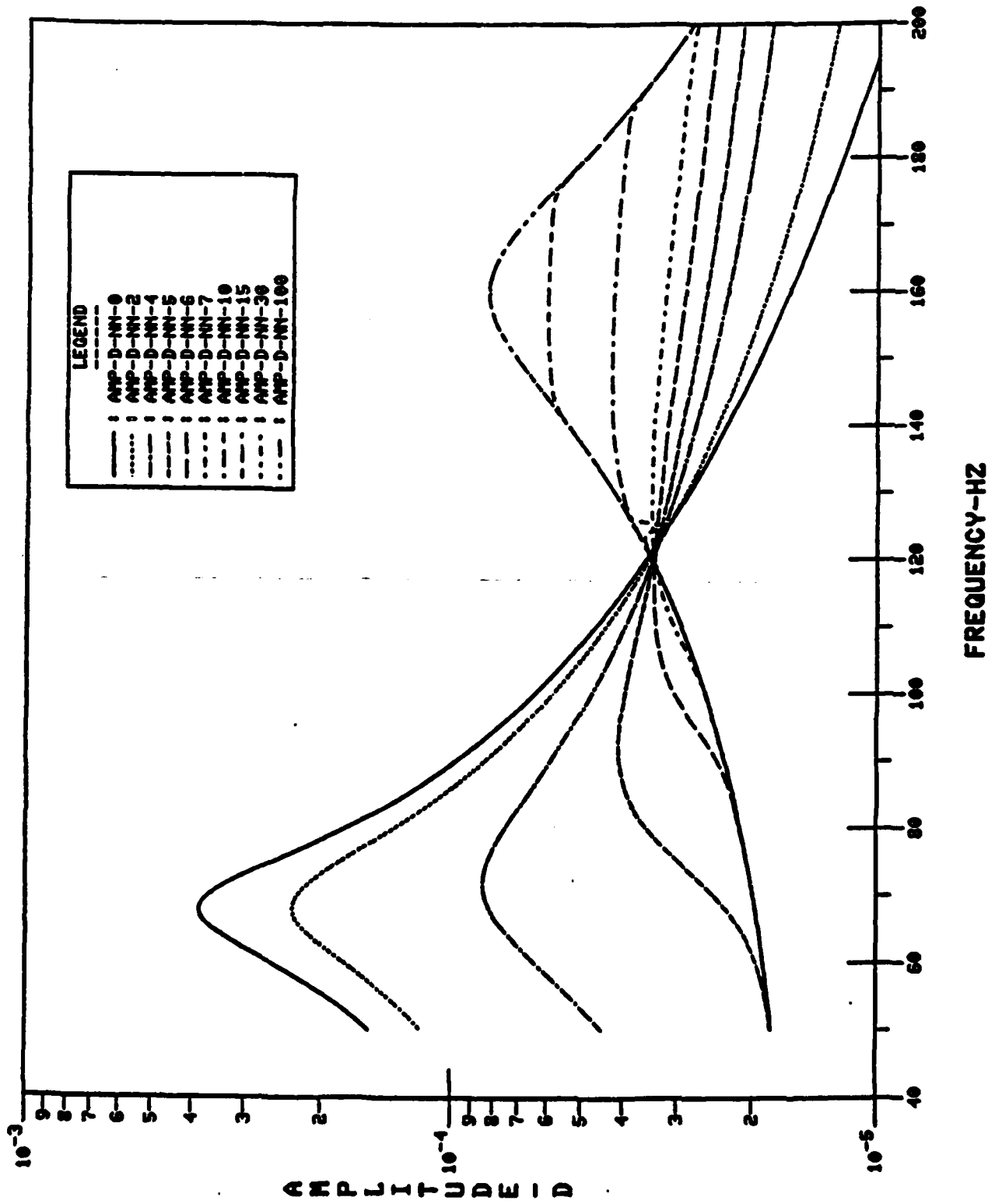

Figure 28. Computed Vibration Response of Lumped Mass Beam with  $\eta=0.2$ ,  $\mu=0.19$ .

In some cases, i.e. no excitation of higher modes, it is only necessary to obtain the optimal friction damping force or greater to eliminate the low frequency mode. This set of data shows that it should not be difficult to accomplish this except in the case where the excitation force is very high. Even in that case a friction damper mechanism should be able to reduce the first mode response peak to an acceptable level.

## 6. CONCLUSIONS

The following conclusions are drawn concerning the friction damping program effort:

1. A useful experimental system was devised for conducting friction damping studies simulating the blade platform to disk friction damping mechanism;
2. A successful method was devised for measuring the coefficient of friction at the appropriate test condition;
3. The lumped mass blade vibration analysis was implemented successfully on the VAX computer system and a plotting routine was developed for the presentation of the computed results;
4. For the tested blade configuration optimal friction damping for platform to disk damping of the blade first and second bending mode vibrations occurred when the friction damping force ( $\mu x N_N$ ) was equal to or slightly greater than the excitation force;
5. Variation of the hysteretic damping loss factor ( $\eta$ ) in the lumped mass computer analysis or of the damper block mass and configuration (rectangular, tapered, curved) in the experimental test do not significantly affect the result expressed above in Conclusion 4;
6. The accuracy of the analytical method needs to be further evaluated by performing experiments where the oscillating harmonic excitation force and the displacement amplitudes are measured. Other blade configurations also should be evaluated.

7. The lumped mass analysis is useful for predicting the responses of blade systems for which the modal parameters can be measured. It would be useful for design purposes only if the required input modal parameters could be estimated accurately.

#### 7. RECOMMENDATIONS

In view of the conclusions drawn, it is suggested that additional studies be conducted in this area. This additional investigation should include, but not necessarily be limited to:

- analytical and experimental study of single blades excited by higher external forces,
- analytical and experimental study of responses of blades having similar spanwise ratios but having higher and lower mass-stiffness ratios, and
- analytical and experimental study of interblade friction damping using two blades and an inter-platform friction damper. Variables in this study should include not only the friction force but also the relative excitation forces and excitation phase relationships.

It is recommended that all experimental work undertaken in the future be quantitative as well as qualitative.

It is recommended that the lumped mass analysis be compared to a simplified finite element analysis for accuracy and for cost effectivity (University of Dayton and Carnegie-Mellon University each have a simplified finite element analysis applicable to this problem).

It is recommended that further studies be performed on the lumped mass analysis computer program to improve its accuracy and cost effectiveness. These studies should make use of a finite element model to discretise the beam and from this arrive at the modal parameters for the lumped mass program. The solutions of the lumped mass program are the modal amplitudes which should be transformed into structural amplitudes by suitable matrix

transformation. Thus, a "hybrid" finite-element lumped mass computer program should be developed which should have the beneficial advantages of both the lumped mass method and the finite element analysis. This should provide very economical computer program running costs, especially for the multiblade analysis. This should also improve the quantitative accuracy of the lumped mass method.

## REFERENCES

- ... E. and Klumpp, J. H., "Analysis of Slip Damping Reference to Turbine-Blade Vibration," Journal of Mechanics, September 1956, pp. 421-429.
- H. and Goodman, L. E., "Slip Damping of Press-fit Under Linearly Varying Pressure," WADC Technical 56-291, Wright Air Development Center, Sept. 1956.
- W. E. and Williams, E. J., "A Linearized Analysis of Frictionally Damped Systems," Journal of Sound and Vibration, 24(4), 1972, pp. 445-458.
- E. J. and Earles, S. W. E., "Optimization of the Design of Frictionally Damped Beam Type Structures Reference to Gas Turbine Compressor Blading," Journal of Engineering for Industry, May 1974, pp. 471-475.
- F. and Williams, J. L., "The Damping of Structural Vibration by Rotational Slip in Joints," Journal of Sound and Vibration, 53(3), 1977, pp. 333-340.
- F. and Imam, I. M. A., "The Damping of Plate Vibration by Interfacial Slip Between Layers," International Journal of Machine Design Research, Vol. 18, 1978, pp. 125-137.
- L., "An Analytical Study of the Energy Dissipation in Commodity Bladed-Disk Assemblies Due to Inter-Shroud Contact Rubbing," Journal of Mechanical Design, Transactions A.S.M.E., Vol. 100, April 1978.
- I. A., "Influence of Some Factors on GTE Turbine Vibrational Energy Dissipation," Izvestiya VUZ. Tekhnicheskaya Tekhnika, Vol. 20, No. 3, 1977, pp. 117-121.
- ..., A. V., Lionberger, S. R., and Brown, K. W., "Finite Element Analysis of an Assembly of Shrouded Blades Using Natural Modes," Journal of Mechanical Design, Vol. 100, 1978, pp. 520-527.

- Griffin, J. H., "Friction Damping of Resonant Stresses in Gas Turbine Engine Airfoils," *Journal of Engineering for Power*, Vol. 102, April 1980, pp. 329-333.
- Srinivasan, A. V., Cutts, D. G., and Sridhar, S., "Turbojet Engine Blade Damping," NASA Contract Report 165406, July 1981.
- Jones, D. I. G. and Muszynska, A., "Effect of Slip on Response of a Vibrating Compressor Blade," paper presented at the Winter Annual Meeting, A.S.M.E., November 27-December 2, 1977.
- Jones, D. I. G. and Muszynska, A., "Effect of Slip on Response of a Vibrating Compressor Blade," A.S.M.E. Paper 77-WA/GT-3, 1977.
- Muszynska, A. and Jones, D. I. G., "On Discrete Modelization of Response of Blades with Slip and Hysteretic Damping," paper presented at the Fifth World Congress on Theory of Machines and Mechanisms, Concordia University, Montreal, Canada, July 8-13, 1979.
- Jones, D.I.G. and Muszynska, A., "Vibration of a Compressor Blade with Slip at the Root," *Shock and Vibration Bulletin* 48, 1978, pp. 53-61.
- Jones, D.I.G. and Muszynska, A., "Design of Turbine Blades for Effective Slip Damping at High Rotational Speeds," *Shock and Vibration Bulletin*, 49(2), 1979, pp. 87-96.
- Jones, D.I.G., Nashif, A. D., and Stargardter, H., "Vibrating Beam Dampers for Reducing Vibrations in Gas Turbine Blades," *Journal of Engineering for Power*, A.S.M.E., January 1975, pp. 111-116.
- Muszynska, A., Jones, D.I.G., Lagnese, T., and Whitford, L., "On Nonlinear Response of Multiple Blade Systems," *Shock and Vibration Symposium*, San Diego, CA, October 1980.

19. Jones, D.I.G. and Muszynska, A., "On Discrete Modelization of Response of Blades with Slip and Hysteretic Damping," Proceedings of the Fifth World Congress on Theory of Machines and Mechanisms, A.S.M.E., 1979.
20. Jones, D.I.G., "Vibrations of a Compressor Blade with Slip at the Root," AFWAL-TR-80-4003, Wright-Patterson Air Force Base, Ohio, April 1980.
21. Rimkunas, D. A. and Frye, H. M., "Investigation of Fan Blade Shroud Mechanical Damping," AFAPL-TR-79-2054, Wright-Patterson Air Force Base, Ohio, June 1979.
22. Dickerson, E. O., "Turbine Blade Structural Dynamic Analysis," AIAA J., 1980, pp. 998-1003.
23. Umemura, S., Mase, M., and Kadoya, Y., "Vibration Analysis of Grouped Blades of Turbines by the Finite Element Method," Technical Review, June 1979.
24. Okamoto, N. and Nakazawa, M., "Finite Element Incremental Contact Analysis with Various Frictional Conditions," International Journal for Numerical Methods in Engineering, Vol. 14, 1979, pp. 337-357.
25. Dokainish, M. A., and Jagannath, D. V., "Experimental Investigation of Gas Turbine Blade Vibration-A Review," presented at the Vibration Conference, A.S.M.E., March 30-April 2, 1969.
26. Beards, C. F., "Some Effects of Interface Preparation on Frictional Damping in Joints," International Journal of Machine Tool Design Research, Vol. 15, pp. 77-83, 1975.
27. Plunkett, R., "Friction Damping," (ed. P. J. Torvik), AMD-V.38, A.S.M.E., 1980, pp. 65-74.
28. Beards, C. F., "Damping in Structural Joints," Shock and Vibration Digest, September 1976, pp. 35-41.
29. Grady, R. F., Jr., "Investigation of Material Damping Properties of Propulsion Turbine Blade Material," Test Report NOBS-9439U, General Electric Company.

30. Cochardt, A. W., "A Method for Determining the Internal Damping of Machine Members," *Journal of Applied Mechanics*, September 1954, pp. 257-262.
31. Wagner, J. T., "Blade Damping Tests," Engineering Report EC-401, Development Engineering Department, Westinghouse Electric Corporation.

