

AD-A120 596

CATHODE-RAY-TUBE RASTER LINE SELECTOR WITH HORIZONTAL
MODULATION CAPABILITY(U) ARMY AEROMEDICAL RESEARCH LAB
FORT RUCKER AL J H HAPGOOD ET AL. SEP 82 USAARL-82-10

1/1

UNCLASSIFIED

F/G 9/1

NL



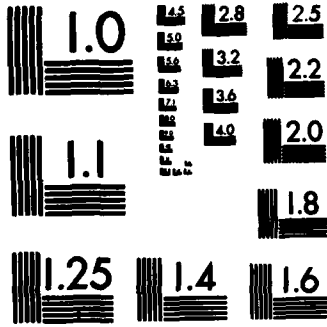

MICROCOPY RESOLUTION TEST CHART
NATIONAL BUREAU OF STANDARDS-1963-A

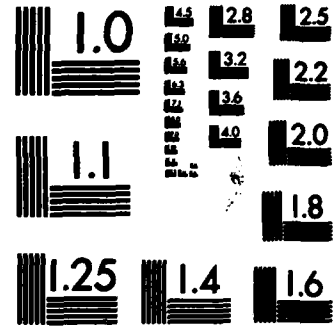

MICROCOPY RESOLUTION TEST CHART
NATIONAL BUREAU OF STANDARDS-1963-A

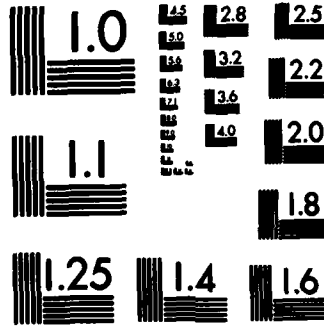

MICROCOPY RESOLUTION TEST CHART
NATIONAL BUREAU OF STANDARDS-1963-A

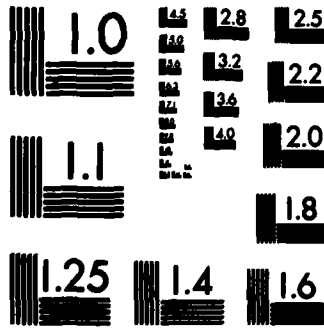

MICROCOPY RESOLUTION TEST CHART
NATIONAL BUREAU OF STANDARDS-1963-A

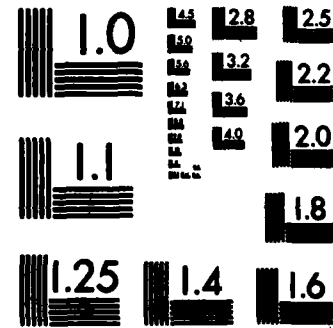

MICROCOPY RESOLUTION TEST CHART
NATIONAL BUREAU OF STANDARDS-1963-A

AD A120596

B

USAARL REPORT NO. 82-10



**CATHODE-RAY-TUBE RASTER LINE SELECTOR
WITH HORIZONTAL MODULATION CAPABILITY**

John H. Hapgood
and
Clarence E. Rash

RESEARCH SYSTEMS DIVISION
SENSORY RESEARCH DIVISION

DTIC
SELECTED
OCT 21 1982

A

This document has been approved
for public release and sale; its
distribution is unlimited.

September 1982

U.S. ARMY AEROMEDICAL RESEARCH LABORATORY
FORT RUCKER, ALABAMA 36362

82 10 21 001

FILE COPY

USAARL

NOTICE

Qualified Requesters

Qualified requesters may obtain copies from the Defense Documentation Center (DDC), Cameron Station, Alexandria, Virginia. Orders will be expedited if placed through the librarian or other person designated to request documents from DDC.

Change of Address

Organizations receiving reports from the US Army Aeromedical Research Laboratory on automatic mailing lists should confirm correct address when corresponding about laboratory reports.

Disposition

Destroy this report when it is no longer needed. Do not return it to the originator.

Disclaimer

The views, opinions, and/or findings contained in this report are those of the author and should not be construed as an official Department of the Army position, policy, or decision, unless so designated by other official documentation. Citation of trade names in this report does not constitute an official Department of the Army endorsement or approval of the use of such commercial items.

Reviewed:

Frank E. Chapple, III, LTC, VC
Director, Research Systems Division

Released for Publication:

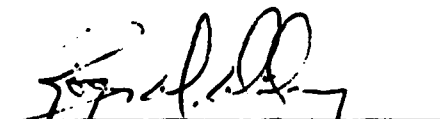
Roger W. Wiley, LTC, MSC
Chairman, Scientific Review
Committee

DUDLEY R. PRICE
Colonel, MC
Commanding

UNCLASSIFIED

SECURITY CLASSIFICATION OF THIS PAGE (When Data Entered)

REPORT DOCUMENTATION PAGE		READ INSTRUCTIONS BEFORE COMPLETING FORM
1. REPORT NUMBER USAARL Report No. 82- 10	2. GOVT ACCESSION NO. AD-A120596	3. RECIPIENT'S CATALOG NUMBER
4. TITLE (and Subtitle) CATHODE-RAY-TUBE RASTER LINE SELECTOR WITH HORIZONTAL MODULATION CAPABILITY		5. TYPE OF REPORT & PERIOD COVERED Final Report
		6. PERFORMING ORG. REPORT NUMBER
7. AUTHOR(s) John H. Hapgood Clarence E. Rash		8. CONTRACT OR GRANT NUMBER(s)
9. PERFORMING ORGANIZATION NAME AND ADDRESS US Army Aeromedical Research Laboratory Fort Rucker, AL 36362		10. PROGRAM ELEMENT, PROJECT, TASK AREA & WORK UNIT NUMBERS 64207.A,4E464207D425, 00,048
11. CONTROLLING OFFICE NAME AND ADDRESS US Army Medical Research & Development Command Fort Detrick Frederick, MD 21701		12. REPORT DATE September 1982
		13. NUMBER OF PAGES 16
14. MONITORING AGENCY NAME & ADDRESS (if different from Controlling Office)		15. SECURITY CLASS. (of this report) Unclassified
		15a. DECLASSIFICATION/DOWNGRADING SCHEDULE
16. DISTRIBUTION STATEMENT (of this Report) Approved for public release; distribution unlimited.		
17. DISTRIBUTION STATEMENT (of the abstract entered in Block 20, if different from Report)		
18. SUPPLEMENTARY NOTES		
19. KEY WORDS (Continue on reverse side if necessary and identify by block number) Raster Line Selector Cathode-Ray-Tube Modulation		
20. ABSTRACT (Continue on reverse side if necessary and identify by block number) A simple and inexpensive circuit which provides a method of selecting the number and position of active raster lines visible on a CRT display is presented. Requiring inputs of vertical drive and horizontal and vertical sync signals, the circuit produces an output which can be fed directly into the video input of the display.		

UNCLASSIFIED

SECURITY CLASSIFICATION OF THIS PAGE(When Data Entered)

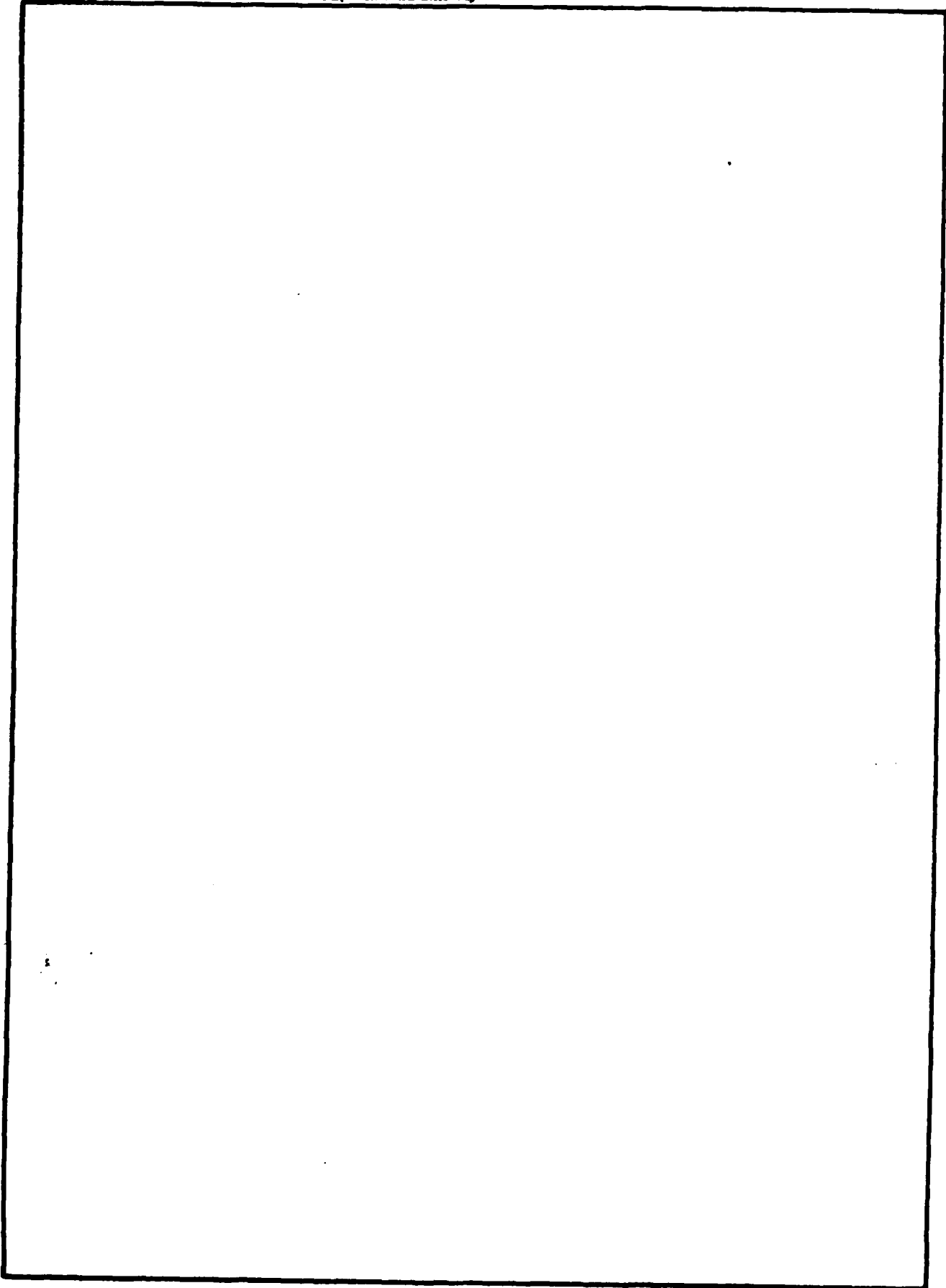

UNCLASSIFIED

SECURITY CLASSIFICATION OF THIS PAGE(When Data Entered)

TABLE OF CONTENTS

	<u>Page No.</u>
List of Illustrations	3
Introduction	5
Circuit Description for Raster Line Selector.	5
Circuit Description for Raster Line Selector with Horizontal Modulation Capability	7
Discussion	8
Appendix List of Components	11

LIST OF ILLUSTRATIONS

<u>Figure</u>		<u>Page No.</u>
1	Schematic for Raster Line Selector Circuit.	6
2	Actual Waveforms for Test Points A - D.	7
3	Schematic for Raster Line Selector Circuit with Horizontal Modulation Capability	8
4	Photographs of Actual Raster Demonstrating Circuit Capabilities.	9

Accession For	
DDIS GRA&I	<input checked="" type="checkbox"/>
DDIS TAB	<input type="checkbox"/>
Unannounced	<input type="checkbox"/>
Justification	
Distribution/	
Availability Codes	
Dist	Avail and/or Special
A	



INTRODUCTION

With the increased usage of cathode-ray-tube (CRT) displays in the areas of target detection and recognition, a greater emphasis has been placed on the ability to measure the image quality of these displays. Much of this effort has been restricted to determining the image quality for static targets. Only recently has attention been focused on dynamic imagery, that is, imagery resulting from relative target/sensor motion.

The US Army Aeromedical Research Laboratory (USAARL) has been investigating the parameters of CRT displays which affect the imaging of targets in motion and techniques that can quantify the image degradation resulting from this motion. In the attempt to develop methods and instrumentation to aid in this investigation, it was decided to enhance the normally available control of the individual raster lines of the CRT display.

To reach this goal, a circuit was developed which provides a simple method of selecting the number and position of active raster lines on the CRT display. The circuit development was actually accomplished in two stages. First, a circuit was developed which allowed the selection of the number of active raster lines and their position. In the second stage, the capability to modulate these lines horizontally was added.

CIRCUIT DESCRIPTION FOR RASTER LINE SELECTOR

The circuit shown in Figure 1* allows the user to select from zero to five active lines and control the vertical position at which they occur on the display. The required inputs are a negative-going vertical blanking signal and horizontal and vertical synchronization pulses.

The active lines are written at the frame rate. In other words, the standard interlacing method of presenting two alternating active fields is defeated. This is accomplished by blanking the electron beam on alternating fields. The number of active lines is controlled by the width of a pulse which turns on the electron beam. The time at which the beam is turned on, referenced to the active field's vertical sync pulse, determines the positioning of the active lines.

* Component values are given in Appendix .

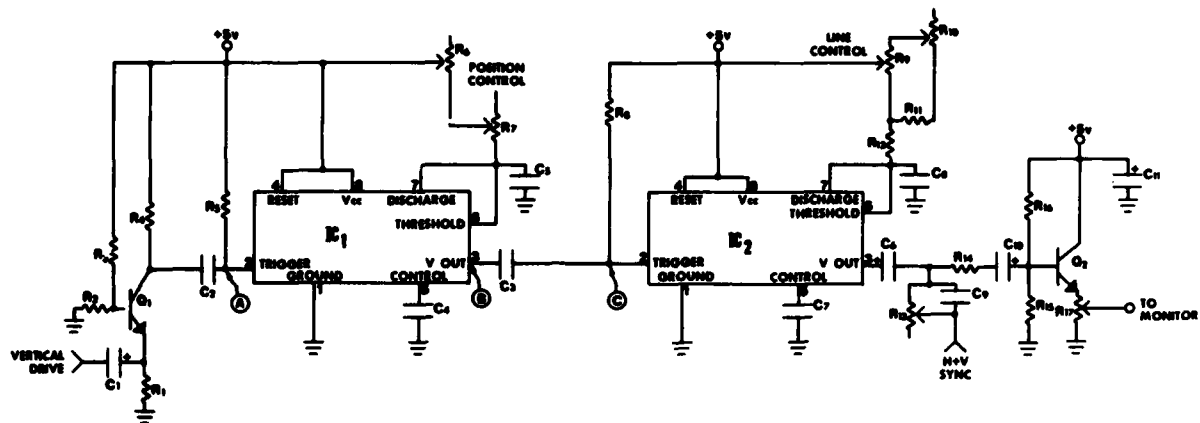

Figure 1. Schematic for raster line selector circuit.

The vertical drive pulses are applied through coupling capacitor C_1 to the emitter of transistor Q_1 which is operating as a common-base amplifier. The amplification insures that the pulses will be of sufficient driving amplitude when they arrive at pin 2 of IC_1 . The amplified vertical drive pulses are taken off of the collector of Q_1 and differentiated by coupling capacitor C_2 and resistor R_5 before being fed into the TRIGGER pin (pin 2) of IC_1 . IC_1 is a 555 timer configured as a monostable multivibrator (one shot). The pulse width of the output pulses available on pin 3 is controlled by capacitor C_5 and the control potentiometer R_6 in combination with R_7 . This potentiometer positions the active raster lines on the display. Actual waveforms present at test points A and B, noted on the schematic, are shown in Figure 2. The differentiated pulses at test point A have a period of 17 msec. The pulses at pin 3 of IC_1 (test point B) can vary in width between 17 and 33 msec. This pulse makes its high to low transition during alternate fields. Where this transition occurs within the field determines the location of the active lines within the field.

The output from pin 3 on IC_1 is differentiated by the RC combination of coupling capacitor C_3 and resistor R_8 . The resulting pulses are fed to the TRIGGER input (pin 2) of IC_2 , which is also a 555 timer used in a monostable multivibrator configuration. The timing period of IC_2 is controlled by capacitor C_8 and the control potentiometer R_9 . Adjusting R_9 , which varies the pulse width of the output of IC_2 , selects the number of lines which will be active on the display. For the values indicated, up to five consecutive lines may be selected, requiring a pulse width of from 0 to 315 μ sec. Waveform C (from test point C) is shown in Figure 2.

The output from pin 3 of IC_2 is then combined with the horizontal and vertical sync pulses and applied to the base of transistor Q_2 which acts as an emitter follower. The final output, taken off of potentiometer R_{17} , can be fed directly into a 75 ohm input on the display.

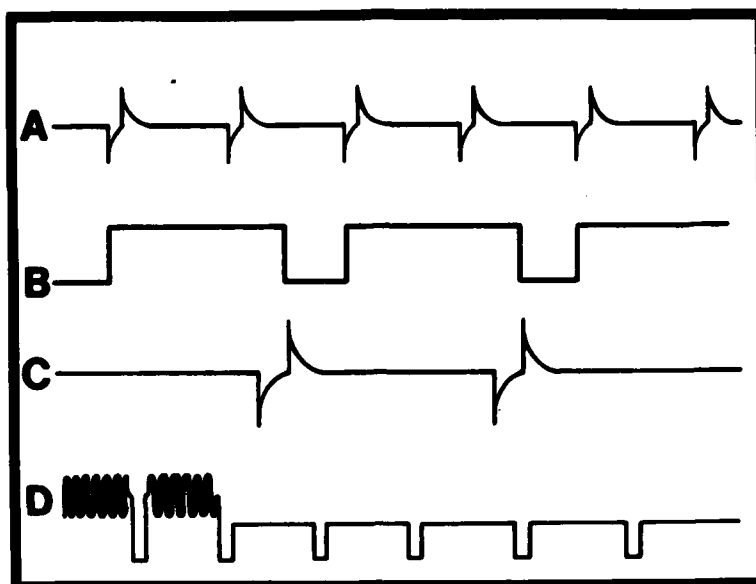

Figure 2. Actual waveforms for test points A - D.

CIRCUIT DESCRIPTION FOR RASTER LINE SELECTOR WITH HORIZONTAL MODULATION CAPABILITY

In order to provide for the capability of modulating the active horizontal raster lines, the previously developed circuit was slightly modified. The new schematic is shown in Figure 3.* The input of the horizontal and vertical sync pulses was moved to the base circuit of the third stage (Q_5) of an added three-stage amplifier. The desired modulating signal is input to the emitter of the first stage (Q_3). The first and second stages are a common-emitter configuration; the third stage is configured as an emitter-follower.

The modulation occurs in the transistor Q_3 . The pulse which arrives at the base of Q_3 has a pulse width equal to ~ 53 usec, or a multiple thereof, the time required for one (or more) horizontal line scan. Transistor Q_3 will have a change in its collector (output) voltage only when the base voltage, i.e., the pulse amplitude, exceeds 0.6v. The signal applied to the emitter of Q_3 will have an effect on the collector (output) voltage only when Q_3 has been turned on. The resulting signal will be modulated pulses of width equal to the horizontal line scan period. The waveform representing this signal (at test point D in Figure 3) is shown in Figure 2.

* Component values are given in Appendix A.

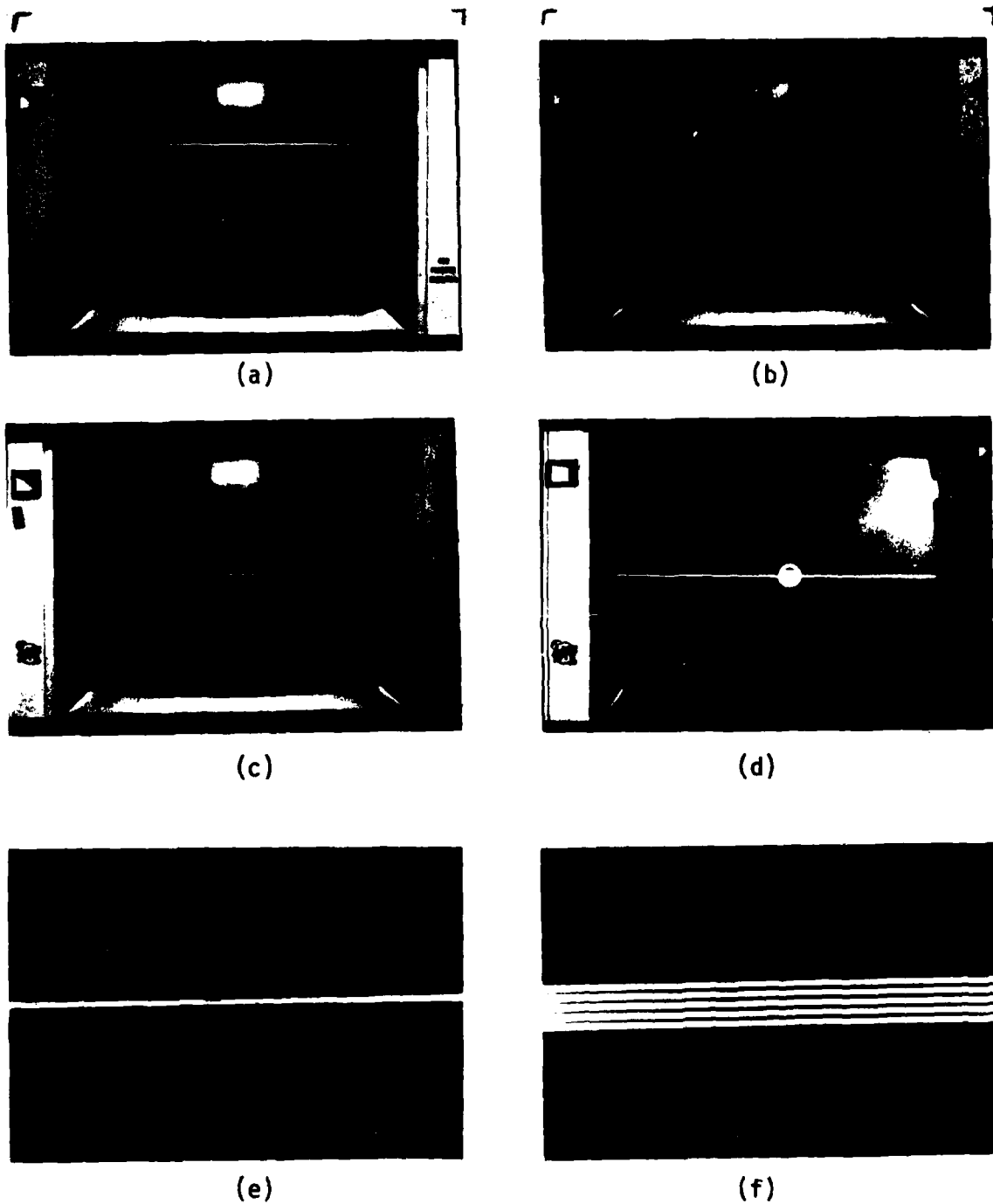

FIGURE 4. Photographs of actual rasters demonstrating circuit capabilities.
 (a and b) Location of active lines can be seen anywhere on display.
 (c and d) The number of raster lines can vary.
 (e and f) Close-up view of actual raster with single and multiple active lines.

APPENDIX
LIST OF COMPONENTS

FOR FIGURE 1

INTEGRATED CIRCUITS

IC₁, IC₂ - 555 Timer

RESISTORS*

R₁ - 270 Ω
R₂ - 2.2K Ω
R₃, R₅, R₈ - 22K Ω
R₄, R₁₄ - 1K Ω
R₆ - 400K Ω
R₇ - 2M Ω
R₉, R₁₀ - 100K Ω
R₁₁ - 62K Ω
R₁₂ - 21K Ω
R₁₃ - 5K Ω
R₁₅ - 6.8K Ω
R₁₆ - 20K Ω
R₁₇ - 500 Ω

TRANSISTORS

Q₁, Q₂ - 2N3904

CAPACITORS

C₁, C₆, C₁₁ - 100 μ f, 10 VDC, electrolytic
C₂, C₃, C₉ - .001 μ f
C₄, C₇ - .01 μ f
C₅ - .039 μ f
C₈ - .0019 μ f
C₁₀ - 200 μ f, 16 VDC, electrolytic

FOR FIGURE 2

INTEGRATED CIRCUITS

IC₁, IC₂ - 555 Timer

RESISTORS*

R₁, R₂₀ - 270 Ω
R₂ - 2.2K Ω
R₃, R₅, R₈ - 22K Ω
R₄, R₁₃, R₂₁, R₂₄ - 1K Ω
R₆ - 400K Ω
R₇ - 2M Ω
R₉, R₁₀ - 100K Ω
R₁₁ - 62K Ω
R₁₂ - 21K Ω
R₁₄ - 6.8K Ω
R₁₅ - 20K Ω
R₁₆ - 2K Ω
R₁₇, R₂₈ - 500 Ω
R₁₈ - 300 Ω
R₁₉ - 4.7K Ω
R₂₂ - 150 Ω
R₂₃ - 3.3K Ω
R₂₅ - 10K Ω
R₂₆ - 47K Ω
R₂₇ - 470 Ω

TRANSISTORS

Q₁, Q₂, Q₃, Q₅ - 2N3904
Q₄ - 2N3906

CAPACITORS

C₁, C₆ - 100 μ f, 10 VDC, electrolytic
C₂, C₃ - .001 μ f
C₄, C₇ - .01 μ f
C₅ - .039 μ f
C₈ - .0019 μ f
C₉ - 200 μ f, 16 VDC, electrolytic
C₁₀, C₁₁ - 10 μ f, 50 VDC, electrolytic
C₁₂ - 47 μ f, 16 VDC, electrolytic

*All fixed resistors are 10%, 1/4-watt.

INITIAL DISTRIBUTION

Defense Technical Information Center Cameron Station Alexandria, VA 22314	(12)	Aeromechanics Laboratory US Army Research & Technology Labs Ames Research Center, M/S 215-1 Moffett Field, CA 94035	(1)
Under Secretary of Defense for Research and Engineering ATTN: Military Assistant for Medical and Life Sciences Washington, DC 20301	(1)	Sixth United States Army ATTN: SMA Presidio of San Francisco, California 94129	(1)
Uniformed Services University of the Health Sciences 4301 Jones Bridge Road Bethesda, MD 20014	(1)	Director Army Audiology & Speech Center Walter Reed Army Medical Center Forest Glen Section, Bldg 156 Washington, DC 20012	(1)
Commander US Army Medical Research and Development Command ATTN: SGRD-RMS/Ms. Madigan Fort Detrick Frederick, MD 21701	(5)	Harry Diamond Laboratories Scientific & Technical Information Offices 2800 Powder Mill Road Adelphi, MD 20783	(1)
Redstone Scientific Information Center ATTN: DRDMI-TBD US Army Missile R&D Command Redstone Arsenal, AL 35809	(1)	US Army Ordnance Center & School Library, Bldg 3071 ATTN: ATSL-DOSL Aberdeen Proving Ground, MD 21005	(1)
US Army Yuma Proving Ground Technical Library Yuma, AZ 85364	(1)	US Army Environmental Hygiene Agency Library, Bldg E2100 Aberdeen Proving Ground, MD 21010	(1)
US Army Aviation Engineering Flight Activity ATTN: DAVTE-M (Technical Library) Edwards AFB, CA 93523	(1)	Technical Library Chemical Systems Laboratory Aberdeen Proving Ground, MD 21010	(1)
US Army Combat Developments Experimentation Command Technical Library HQ, USACDEC Box 22 Fort Ord, CA 93941	(1)	US Army Materiel Systems Analysis Agency ATTN: Reports Distribution Aberdeen Proving Ground, MD 21005	(1)

Commander US Army Medical Research Institute of Chemical Defense Aberdeen Proving Ground, MD 21010	(1)	US Army Field Artillery School Library Snow Hall, Room 16 Ft Sill, OK 73503	(1)
Commander Naval Air Development Center ATTN: Code 6022 (Mr. Brindle) Warminster, PA 18974	(1)	US Army Dugway Proving Ground Technical Library Bldg 5330 Dugway, UT 84022	(1)
Director Ballistic Research Laboratory ATTN: DRDAR-TSB-S (STINFO) Aberdeen Proving Ground, MD 21005	(2)	US Army Materiel Development & Readiness Command ATTN: DRCSG 5001 Eisenhower Avenue Alexandria, VA 22333	(1)
US Army Research & Development Technical Support Activity Fort Monmouth, NJ 07703	(1)	US Army Foreign Science & Technology Center ATTN: DRXST-IS1 220 7th St., NE Charlottesville, VA 22901	(1)
Commander/Director US Army Combat Surveillance & Target Acquisition Laboratory ATTN: DELCS-D Fort Monmouth, NJ 07703	(1)	Commander US Army Training and Doctrine Command ATTN: ATCD Fort Monroe, VA 23651	(2)
US Army Avionics R&D Activity ATTN: DAVAA-0 Fort Monmouth, NJ 07703	(1)	Commander US Army Training and Doctrine Command ATTN: Surgeon Fort Monroe, VA 23651	(1)
US Army White Sands Missile Range Technical Library Division White Sands Missile Range New Mexico 88002	(1)	US Army Research & Technology Labs Structures Laboratory Library NASA Langley Research Center Mail Stop 266 Hampton, VA 23665	(1)
Chief Benet Weapons Laboratory LCWSL, USA ARRADCOM ATTN: DRDAR-LCB-TL Watervliet Arsenal Watervliet, NY 12189	(1)	Commander 10th Medical Laboratory ATTN: DEHE (Audiologist) APO New York 09180	(1)
US Army Research & Technology Labs Propulsion Laboratory MS 77-5 NASA Lewis Research Center Cleveland, OH 44135	(1)	Commander US Army Natick R&D Laboratories ATTN: Technical Librarian Natick, MA 01760	(1)

Commander US Army Troop Support & Aviation Materiel Readiness Command ATTN: DRSTS-W St. Louis, MO 63102	(1)	US Air Force Armament Development & Test Center Technical Library Eglin AFB, FL 32542	(1)
Commander US Army Aviation R&D Command ATTN: DRDAV-E 4300 Goodfellow Blvd St. Louis, MO 63166	(1)	US Air Force Institute of Technology (AFIT/LDE) Bldg 640, Area B Wright-Patterson AFB, OH 45433	(1)
Director US Army Human Engineering Laboratory ATTN: Technical Library Aberdeen Proving Ground, MD 21005	(1)	US Air Force Aerospace Medical Division School of Aerospace Medicine Aeromedical Library/TSK-4 Brooks AFB, TX 78235	(1)
Commander US Army Aviation R&D Command ATTN: Library 4300 Goodfellow Blvd St. Louis, MO 63166	(1)	Director of Professional Services Office of The Surgeon General Department of the Air Force Washington, DC 20314	(1)
Commander US Army Health Services Command ATTN: Library Fort Sam Houston, TX 78234	(1)	Human Engineering Division Air Force Aerospace Medical Research Laboratory ATTN: Technical Librarian Wright-Patterson AFB, OH 45433	(1)
Commandant US Army Academy of Health Sciences ATTN: Library Fort Sam Houston, TX 78234	(1)	US Navy Naval Weapons Center Technical Library Division Code 2333 China Lake, CA 93555	(1)
Commander US Army Airmobility Laboratory ATTN: Library Fort Eustis, VA 23604	(1)	US Navy Naval Aerospace Medical Institute Library Bldg 1953, Code 012 Pensacola, FL 32508	(1)
Air University Library (AUL/LSE) Maxwell AFB, AL 36112	(1)	US Navy Naval Submarine Medical Research Lab Medical Library, Naval Submarine Base Box 900 Groton, CT 06340	(1)
US Air Force Flight Test Center Technical Library, Stop 238 Edwards AFB, CA 93523	(1)	Staff Officer, Aerospace Medicine RAF Staff British Embassy 3100 Massachusetts Avenue, N.W. Washington, DC 20008	(1)
Command Surgeon Rapid Deployment Joint Task Force MacDill AFB, FL 33608	(1)		

Director Naval Biosciences Laboratory Naval Supply Center, Bldg 844 Oakland, CA 94625	(1)	Commanding Officer Naval Biodynamics Laboratory P.O. Box 29407 New Orleans, LA 70189	(1)
Naval Air Systems Command Technical Library AIR 950D RM 278 Jefferson Plaza II Department of the Navy Washington, DC 20361	(1)	FAA Civil Aeromedical Institute ATTN: Library Box 25082 Oklahoma City, OK 73125	(1)
US Navy Naval Research Laboratory Library Code 1433 Washington, DC 20375	(1)	Department of Defence R.A.N. Research Laboratory P.O. Box 706 Darlinghurst, N.S.W. 2010 Australia	(1)
US Navy Naval Air Development Center Technical Information Division Technical Support Department Warminster, PA 18974	(1)	Canadian Society of Avn Med c/o Academy of Medicine, Toronto ATTN: Ms. Carmen King 288 Bloor Street West Toronto, Ontario M5S 1V8	(1)
Human Factors Engineering Division Aircraft & Crew Systems Technology Directorate Naval Air Development Center Warminster, PA 18974	(1)	COL F. Cadigan DAO-AMLOUS B Box 36, US Embassy FPO New York 09510	(1)
US Navy Naval Research Laboratory Library Shock & Vibration Information Center Code 8404 Washington, DC 20375	(1)	DCIEM/SOAM MAJ J. Soutendam (Ret.) 1133 Sheppard Avenue West P.O. Box 2000 Downsview, Ontario M3M 3B9	(1)
Director of Biological & Medical Sciences Division Office of Naval Research 800 N. Quincy Street Arlington, VA 22217	(1)	Dr. E. Hendler Code 6003 Naval Air Development Center Warminster, PA 18974	(1)
Commanding Officer Naval Medical R&D Command National Naval Medical Center Bethesda, MD 20014	(1)	Commander US Army Transportation School ATTN: ATSP-TD-ST Fort Eustis, VA 23604	(1)
Commanding Officer 404 Maritime Training Squadron Canadian Forces Base Greenwood Greenwood, N. S. BOP 1N0 Canada ATTN: Aeromedical Training Unit WO P. Handy or Capt S. Olsen	(1)		