

MICROCOPY RESOLUTION TEST CHART
NATIONAL BUREAU OF STANDARDS-1963-A

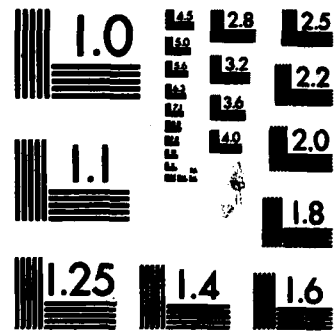

MICROCOPY RESOLUTION TEST CHART
NATIONAL BUREAU OF STANDARDS-1963-A

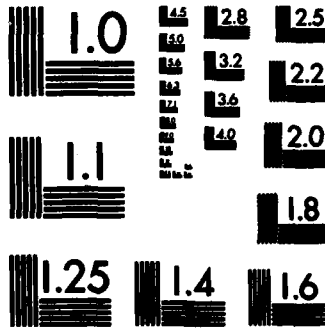

MICROCOPY RESOLUTION TEST CHART
NATIONAL BUREAU OF STANDARDS-1963-A

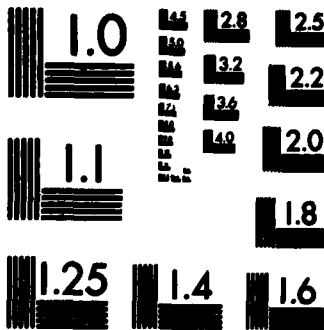

MICROCOPY RESOLUTION TEST CHART
NATIONAL BUREAU OF STANDARDS-1963-A

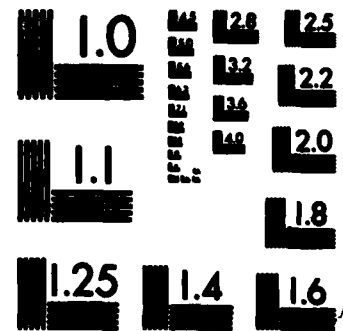

MICROCOPY RESOLUTION TEST CHART
NATIONAL BUREAU OF STANDARDS-1963-A

| | | | |
|--|--|---|---|
| 1. Report No. FAA-RD-81-103 | 2. Government Accession No. AD-A220652 | 3. Recipient's Catalog No. | |
| 4. Title and Subtitle The AMPS Computer System; Design and Operation | | 5. Report Date 9 September 1982 | 6. Performing Organization Code |
| 7. Author(s) Jeffrey L. Gertz and Arnold D. Kaminsky | | 8. Performing Organization Report No. ATC-110 | |
| 9. Performing Organization Name and Address Massachusetts Institute of Technology Lincoln Laboratory P.O. Box 73 Lexington, MA 02173-0073 | | 10. Work Unit No. | 11. Contract or Grant No. DOT-FA7WAI-242 |
| 12. Sponsoring Agency Name and Address Department of Transportation Federal Aviation Administration Systems Research and Development Service Washington, D.C. 20591 | | 13. Type of Report and Period Covered Project Report | |
| 15. Supplementary Notes The work reported in this document was performed at Lincoln Laboratory, a center for research operated by Massachusetts Institute of Technology, under Air Force Contract F19628-80-C-0002. | | 14. Sponsoring Agency Code | |
| 16. Abstract The Lincoln Laboratory Air Traffic Control Radar Beacon System (ATCRBS) Monopulse Processing System (AMPS) is a mobile, stand-alone, ATCRBS surveillance sensor for processing and disseminating target reports from transponder-equipped aircraft. AMPS is essentially the ATCRBS portion of the Mode Select Beacon System (Mode S), a system designed to be an evolutionary replacement for the present third generation ATCRBS. AMPS utilizes several new features introduced by the Mode S sensor concept. In particular, the use of monopulse angle estimation permits more accurate aircraft azimuth estimation with fewer replies per scan, and improved decoding (identification) performance when garble is present. This report provides a description of the details and philosophy of the AMPS computer system implementation and operation. In particular, specific and detailed descriptions of the interrelations between AMPS's several subsystems and subtasks are provided as well as a guide on how to run them. | | | |
| 17. Key Words Air traffic control Beacon System Mode S beacon system Target-to-Track Correlation Monopulse angle estimation Surveillance processing | | 18. Distribution Statement Document is available to the public through the National Technical Information Service, Springfield, Virginia 22161 | |
| 19. Security Class. (of this report) Unclassified | 20. Security Class. (of this page) Unclassified | 21. No. of Pages 118 | 22. Price |

DTIC
OCT 25 1982
H

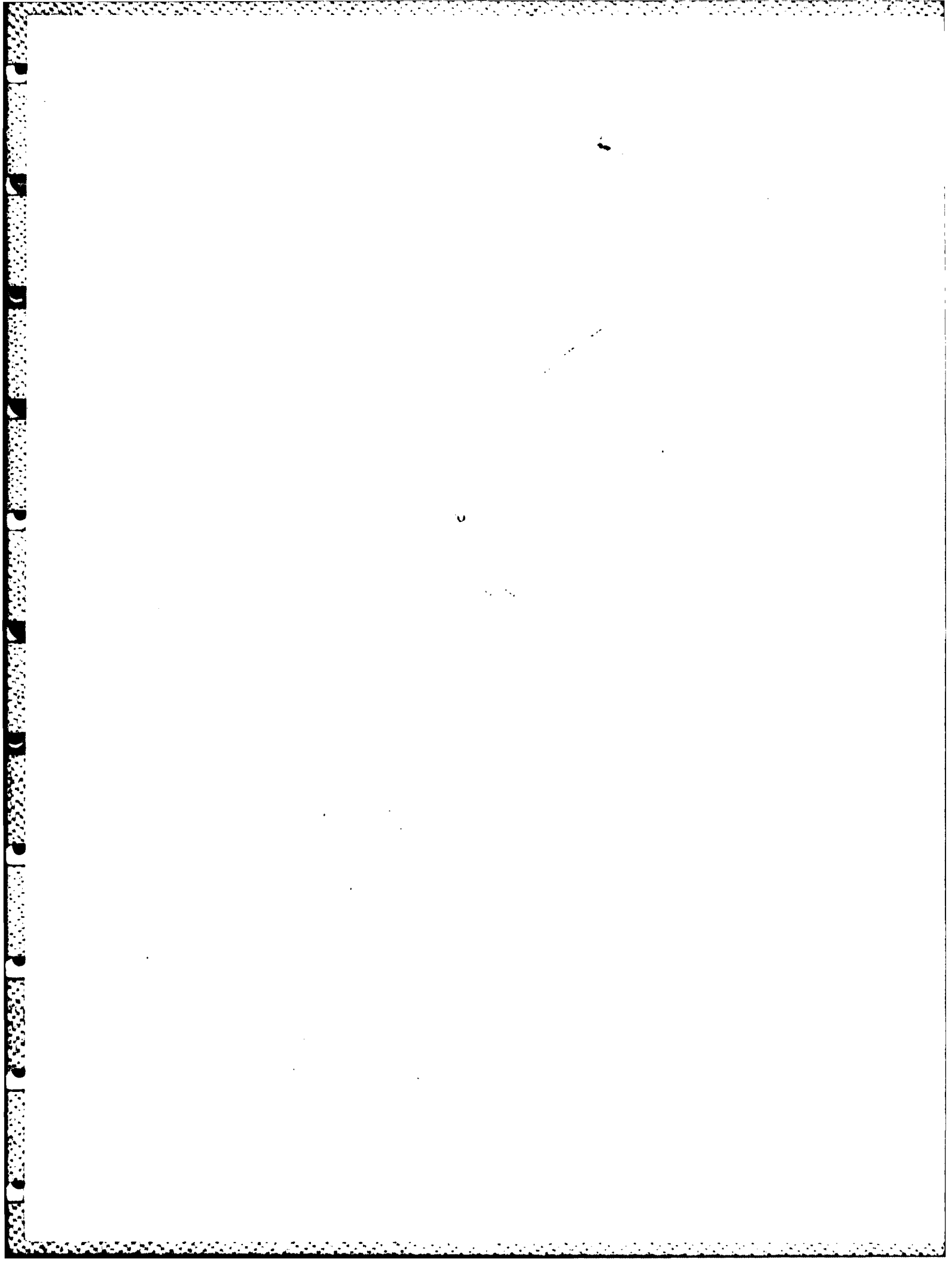

CONTENTS

| | <u>Page</u> |
|-------------------------------------|-------------|
| 1. INTRODUCTION | 1 |
| 2. AMPS OVERVIEW | 2 |
| 3. AMPS HARDWARE/SOFTWARE INTERFACE | 7 |
| 3.1 AMPS States | 7 |
| 3.2 Computer Status Interface | 11 |
| 3.2.1 Range Gate Closed Condition | 11 |
| 3.2.2 System Standby Condition | 13 |
| 3.2.3 System Run Condition | 14 |
| 3.2.4 Contents of the Data Field | 14 |
| 4. SURVEILLANCE PROCESSING TASKS | 18 |
| 4.1 Reply Processor Task | 18 |
| 4.2 Reply Correlation Task | 21 |
| 4.3 Target/Track Correlation Task | 21 |
| 4.3.1 Discrete Code Correlation | 21 |
| 4.3.2 Target-to-Track Association | 22 |
| 4.3.3 Target-to Track Correlation | 22 |
| 4.4 Track Update Task | 23 |
| 4.4.1 Track Initiation | 23 |
| 4.4.2 Track Update | 24 |
| 4.4.3 False Alarm Target Reports | 24 |
| 4.4.4 Output Reports | 25 |
| 5. INTERTASK TIMING AND CONTROL | 26 |
| 5.1 Task Scheduling | 26 |
| 5.1.1 Reply Processing Task | 26 |
| 5.1.2 Reply Correlation Task | 28 |
| 5.1.3 Target/Track Correlation Task | 30 |
| 5.1.4 Track Update Task | 30 |
| 5.2 Task Timing | 30 |
| 5.2.1 Normal Timing | 34 |
| 5.2.2 Reply Processor Overload | 36 |
| 5.2.3 Reply Correlation Overload | 36 |
| 5.2.4 Sector Processor Overload | 36 |
| 6. CALIBRATION | |
| 6.1 Calibration Routine | 40 |
| 6.2 Curve Fitting Algorithm | 40 |
| 7. AMPS DATA RECORDING | |
| 7.1 Parameter Blocks | 42 |
| 7.2 Target Report Blocks | 49 |
| 7.3 Track Report Blocks | 49 |
| 8. AMPS DATA DISPLAY AND OUTPUT | |
| 8.1 Output Buffer | 49 |
| 8.2 Buffer Structure | 49 |



| | |
|--------------------|-------------------------------------|
| Accession For | |
| NTIS GRA&I | <input checked="" type="checkbox"/> |
| DTIC TAB | <input type="checkbox"/> |
| Unannounced | <input type="checkbox"/> |
| Justification | <input type="checkbox"/> |
| By _____ | |
| Distribution/ | |
| Availability Codes | |
| Dist | Avail and/or |
| | Special |
| A | |

CONTENTS

| | <u>Page</u> |
|--|-------------|
| 9. AMPS MICROPROCESSOR INTERFACE | 64 |
| 9.1 Megatek Interface Software | 64 |
| 9.2 NAS Interface Software | 69 |
| 9.3 ADCCP (ARTS) Interface Software | 69 |
| 10. AMPS HARDWARE OPERATIONS | 75 |
| 10.1 AMPS Hardware Reply Processor | 75 |
| 10.1.1 Power Supply Switches | 75 |
| 10.1.2 AMPS System Control Switches | 75 |
| 10.1.3 Display Select Switch | 75 |
| 10.1.4 PM Data Switches | 79 |
| 10.1.5 Azimuth Sector Select and Reset Switches | 79 |
| 10.1.6 Alarm Indicators | 79 |
| 10.2 11/55 Operations | 79 |
| 10.2.1 Off-Line/On-Line Switch | 79 |
| 10.2.2 Read/Write Range | 83 |
| 10.2.3 Front Panel Switches | 83 |
| 10.2.4 Program Tapes | 85 |
| 11. LOADING, RUNNING, AND OUTPUT OF SPECIFIC PROCESSORS | 86 |
| 11.1 Calibration Process | 86 |
| 11.2 Surveillance Processing | 88 |
| 11.2.1 AMPS Control | 89 |
| 11.3 Post-Run Evaluation Process | 89 |
| 11.3.1 Post-Processor Output | 90 |
| 11.4 Playback Process | 96 |
| 11.5 DR11-K Diagnostic | 97 |
| 11.6 DR11-B Diagnostic | 99 |
| 11.7 Sweep Dump Diagnostic | 101 |
| 11.8 Microprocessor Output Diagnostic | 103 |
| 12. AMPS DISPLAY OPERATING PROCEDURES | 105 |
| 12.1 Power Up | 105 |
| 12.2 Booting in the Program | 105 |
| 12.3 Responses to the "PARAM?" Prompt in the Upper Left-Hand Corner | 107 |
| 12.4 Responding to the "CMD?" Prompt in the Upper Left-Hand Corner | 108 |
| 12.4.1 Report Symbols | 109 |
| 12.4.2 Display Types for E&I Commands | 109 |
| 12.4.3 Joystick Control | 109 |
| 12.4.4 Tag Message | 110 |
| 12.5 Use of Switch Register | 111 |
| REFERENCES | 112 |

ILLUSTRATIONS

| <u>Figure</u> | <u>Page</u> |
|--|-------------|
| 2-1 AMPS Block Diagram. | 3 |
| 2-2 Scan Dissection. | 4 |
| 2-3 An ATCRBS Reply. | 5 |
| 3-1 Reply Message from AMPS Hardware. | 8 |
| 3-2 System Run/Standby Period. | 9 |
| 3-3 Sweep Period. | 10 |
| 3-4 Status Word Format | 12 |
| 3-5 Performance Monitor Data (Sheet 1 of 2). | 15 |
| 3-5 Performance Monitor Data (Sheet 2 or 2). | 16 |
| 3-6 System Parameter Data. | 17 |
| 4-1 Sweep Processing. | 19 |
| 4-2 Sector Processing. | 20 |
| 5-1 Reply Processor Task. | 27 |
| 5-2 Reply Correlation Task. | 29 |
| 5-3 Target/Track Correlation Task. | 31 |
| 5-4 Track Update Task. | 32 |
| 5-5 Sector Processing Boundaries. | 33 |
| 5-6 Typical Set of Sweeps over One Sector. | 35 |
| 5-7 Reply Processing Falls Behind. | 37 |
| 5-8 Reply Correlation Falls Behind. | 38 |
| 5-9 Sector Processing Falls Behind. | 39 |
| 6-1 Monopulse Antenna Beam Pattern. | 41 |
| 6-2 Calibration Flow Diagram (1 of 3). | 43 |
| 6-2 Calibration Flow Diagram (2 of 3). | 44 |
| 6-2 Calibration Flow Diagram (3 of 3). | 45 |
| 6-3 Monopulse Reference Cells. | 46 |
| 6-4 Sample Monopulse Calibration Curve. | 48 |
| 7-1 AMPS Tape Record. | 50 |
| 7-2 AMPS Hardware Performance Monitor Data. | 51 |
| 7-3 Active Sensor Range. | 52 |
| 7-4 AMPS Software Surveillance Processing Characteristics. | 53 |
| 7-5 Calibration Performance Monitoring Equipment. | 54 |
| 7-6 IBLK 631 Target Report (1 of 2). | 55 |
| 7-6 IBLK 631 Target Report (2 of 2). | 56 |
| 7-7 AMPS Surveillance Track. | 59 |
| 8-1 Surveillance Output Buffer. | 61 |
| 8-2 I/Ø Data Structures. | 63 |

ILLUSTRATIONS

| <u>Figure</u> | <u>Page</u> |
|---------------------------------------|-------------|
| 9-1 Microprocessor Interface. | 65 |
| 9-2 Interface Data Lines. | 66 |
| 9-3 Flow Chart of the Microprocessor. | 67 |
| 9-4 Microprocessor Interrupt Routine. | 68 |
| 9-5 NAS Report Format (1 of 2). | 70 |
| 9-5 NAS Report Format (2 of 2). | 71 |
| 9-6 ADCCP Header Format. | 73 |
| 9-7 ADCCP Report Format. | 74 |
| 10-1 AMPS Rack Front Panel. | 76 |
| 10-2 AMPS Rack Power Supply. | 77 |
| 10-3 AMPS Rack Azimuth Select Panel. | 78 |
| 10-4 Mounting Tape. | 80 |
| 10-5 Tape Threading. | 81 |
| 10-6 Dismounting Tape. | 82 |
| 10-7 System Operator's Console. | 84 |
| 12-1 MEGATEK Display | 106 |

1. INTRODUCTION

The Lincoln Laboratory Air Traffic Control Radar Beacon System (ATCRBS) Monopulse Processing System (AMPS) is a mobile, stand-alone, ATCRBS surveillance sensor for processing and disseminating target reports from transponder-equipped aircraft. AMPS is essentially the ATCRBS portion of the Mode Select System (Mode S), a system designed to be an evolutionary replacement for the present third generation ATCRBS. AMPS utilizes several new features introduced by the Mode S sensor concept. In particular, the use of monopulse angle estimation permits more accurate aircraft azimuth estimation with fewer replies per scan, and improved decoding (identification) performance when garble is present.

The major tasks performed by the AMPS System are:

- Determining the range, azimuth, and code of each received ATCRBS reply.
- Grouping replies from the same aircraft into target reports and discarding fruit replies.
- Identifying false alarm target reports which occur from reflections, coincident fruit, splitting, or ringaround.
- Initiating and maintaining a track on all aircraft in the covered airspace.

The first function has been implemented in hardware while the remaining functions are performed by software in a DEC 11/55 computer. The hardware consists of a conventional ATCRBS interrogator, monopulse receiver, and ATCRBS Reply Processor. The latter were developed for the Mode S Sensor. This report deals with the AMPS computer system only.

Although the AMPS system described in this report is based upon the specifications contained in the Mode S Engineering Requirements (Ref. 1), there are several differences between AMPS and an ER system. Most importantly, AMPS is meant to be a test and evaluation tool, not an engineering model. Thus, no reliability features are included, and full performance cannot be assured in dense traffic environments. Rather, AMPS degrades in a planned fail-soft manner in such situations.

The purpose of this report is to provide a description of the details and philosophy of the AMPS computer system implementation and operation. In particular, specific and detailed descriptions of the interrelations between AMPS's several subsystems and subtasks are provided as well as a guide on how to run them. More extensive descriptions of the AMPS algorithms themselves may be found in Ref. 2.

AMPS as described herein was field tested at Albuquerque, NM, in June of 1978. At present, the system is operational and being utilized for various Mode S-related projects and tests at Lincoln Laboratory. Minor upgrades to AMPS have occurred since the 1978 test, but none have been made that affect the system at the level of detail presented in this report.

2. AMPS OVERVIEW

The overall AMPS block diagram is presented in Fig. 2-1. The top section, within the dashed lines, is the hardware portion of this system (transmission paths for interrogations are not shown for simplicity). A full description of this hardware can be found in Ref. 3 and 4.

AMPS employs a scanning antenna for the surveillance of aircraft at all azimuths. Figure 2-2 illustrates how a scan is divided into sectors and sweeps. A sweep, the basic system unit, is a single interrogation/reply period for the antenna. Each sweep, ATCRBS replies of the format shown in Fig. 2-3 are received from all beacon-equipped aircraft within the beam. In addition, extraneous replies, called fruit, may be received due to the actions of other ATCRBS sensors in the geographic region.

The function of the hardware reply processor is to identify all ATCRBS replies by searching the received pulse train for framing pulse pairs and then to decide which (if any) of the code pulses are present for each reply. The hardware also determines the range of each reply, from the time of arrival of the first pulse, and the azimuth of each reply, from the monopulse samples of all pulses received. The replies for a sweep are stored in a hardware internal buffer and once each sweep are transferred over a direct memory access device (DMA) into a Digital Equipment PDP 11/55 computer.

These replies are then processed, formed into target reports, and output by four software tasks in the 11/55 computer. These tasks constitute a real-time, interrupt-driven, multi-tasking system. The details of the task timing and control, and various fail-soft operations during overload, are presented in this report.

The first software task in the computer receives the replies and performs the preliminary functions of:

- Range limiting
- Monopulse azimuth correction
- Reply filtering
- Reply buffering for the reply correlation and target formation task.

The second software task performs the reply correlation and target declaration functions. Replies from the latest sweep are compared with replies from earlier sweeps to identify those groups which are close in range, azimuth, and code. Reply groupings so identified will have their data fields merged and a target report declared. Reports which are produced in this manner are then buffered and passed once per azimuth sector to the sector processing tasks.

The sector processing tasks perform four basic functions: track initiation, target-to-track correlation, track update, and data output. Track initiation creates entities from the scan-to-scan correlation of target reports, which should represent real aircraft. These tracks are strictly

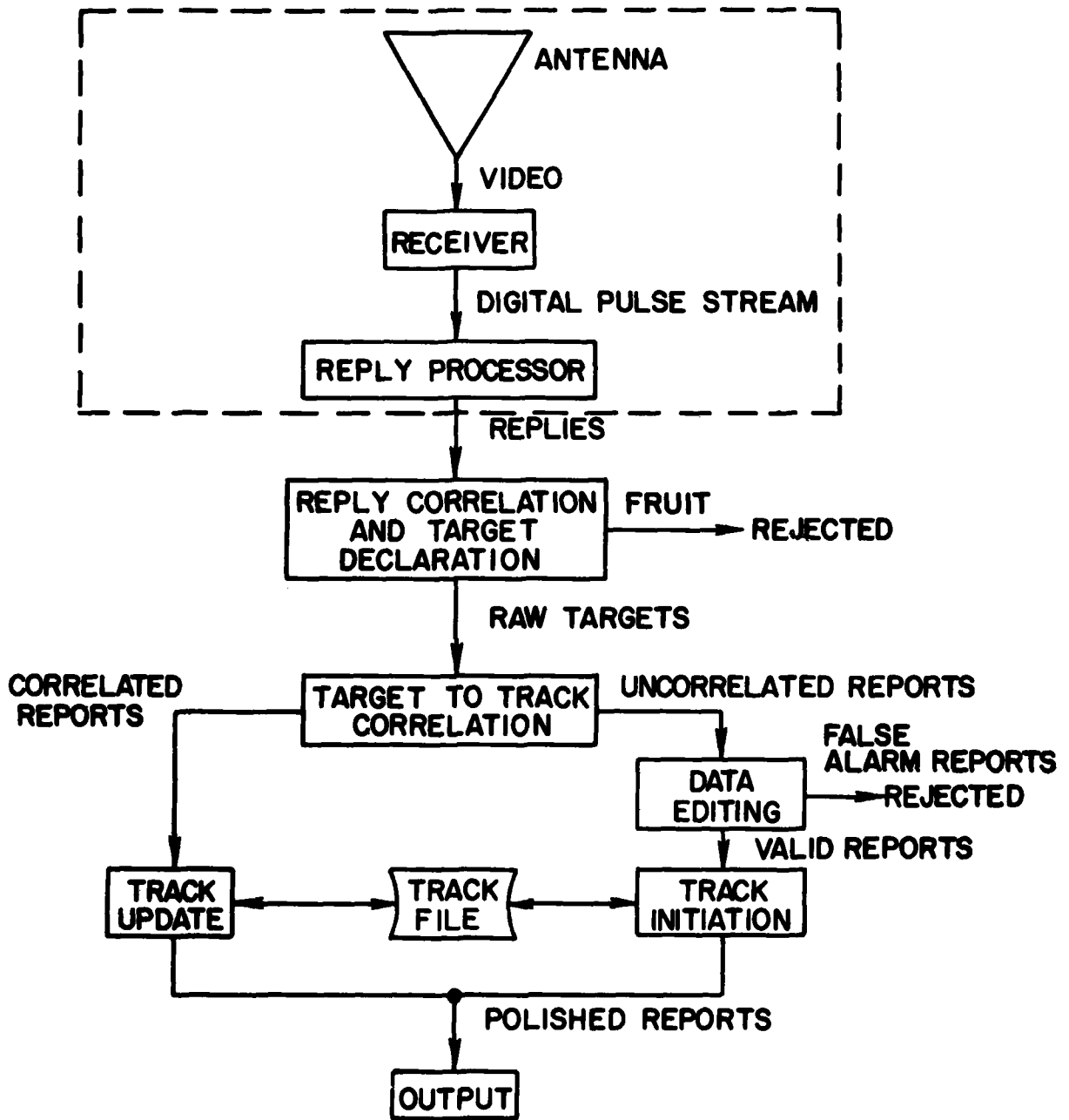
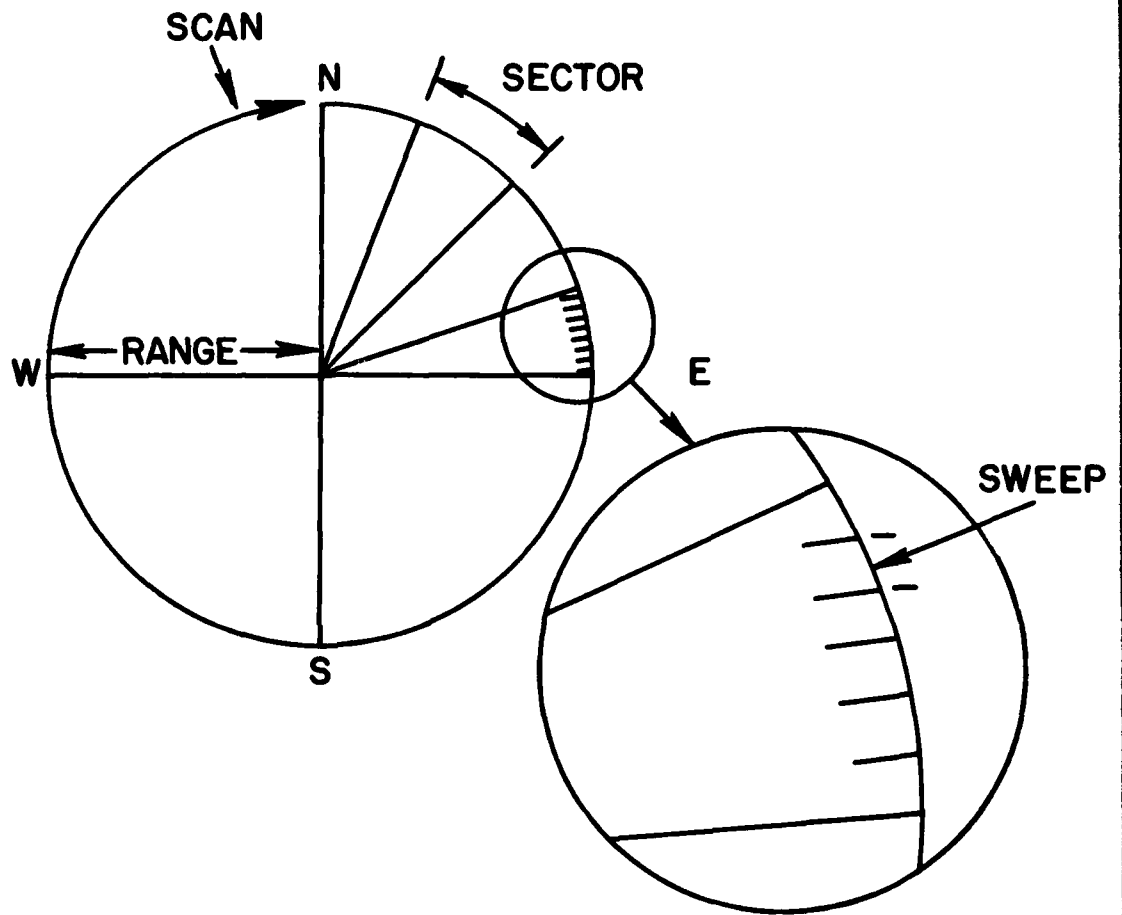
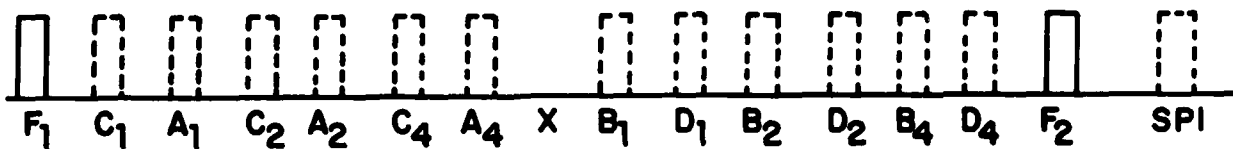

Fig. 2-1. AMPS Block Diagram.



A single 360° antenna rotation is called a scan. An AMPS scan is divided into discrete wedges called sectors. There are a maximum of 32 sectors per scan with each sector divided into time periods called sweeps. The number of sweeps in a scan is determined by the PRF (Pulse Repetition Frequency) and the rotation rate of the antenna.

Fig. 2-2. Scan Dissection.



F₁, F₂ are framing pulses (always present), 20.3 μ sec apart.

Each pulse is nominally 0.5 μ sec wide.

Interpulse spacing is 1.45 μ sec.

X position is normally unused.

SPI pulse, used for signalling, is 3 positions beyond F₂.

Fig. 2-3. An ATCRBS Reply.

internal elements used to improve current target report data quality and reliability through reference to previous scans' information. Target-to-track correlation identifies new data for each track, which is then used by the track update subtask to maintain these tracks. The data output subtask performs the dissemination and recording of target report information for immediate display or future examination and analysis. This output can be to tape, to a local AMPS display, or to existing ATC facilities.

During the AMPS run, each task compiles a large set of timing, performance, and analysis statistics. At the completion of the run, these values are recorded on the output tape. A separate task (the fourth below) can then be executed which processes these statistics and prints a summary of the run. This capability provides an immediate review of the system's performance, so that a rerun may be made without delay if a problem has arisen.

In addition to the tasks which comprise the AMPS surveillance processor, there are several auxiliary tasks in the overall AMPS system. They are:

- A set of system checkout tasks which measure the state of the AMPS hardware/software interface.
- A calibration task which sets certain run-time parameters as well as creating a monopulse azimuth correction table.
- A playback task which inputs surveillance data from a previously made data tape.
- A post-run quick-look analysis task which produces summary statistics from a newly-made data tape.

Each of these auxiliary tasks is discussed in this report. In addition, a detailed series of directions for running AMPS in each of its various modes is presented.

3. AMPS HARDWARE/SOFTWARE INTERFACE

The interface between the AMPS hardware and the DEC 11/55 computer consists of two I/O channels, a DR11-B and a DR11-K. The DR11-B is a high-speed DMA device used to transmit reply data from the hardware reply processor to a computer input buffer. The DR11-K is a low-speed device used to transmit a single status word per sweep to the computer. For each such status transfer, the hardware generates an interrupt to the computer which signals both the presence of this word and that all reply data has arrived via the DR11-B channel.

The hardware reply processor generates eight 16-bit words for each reply it identifies. These words are stored in an internal buffer of size 128 words. As soon as any data is available the DR11-B transfers it from this buffer to one of two buffers in the computer. The speed of this transfer is sufficient to prevent the hardware buffer from overflowing even at maximum reply burst rate. The computer buffer, in turn, is emptied each sweep by the software reply processor task while the alternate buffer is being filled by the next sweep's data.

The format of each reply entry is provided by Fig. 3-1. As shown, some fields are necessary for surveillance (range, code, azimuth) while others provide checks on the hardware performance. Even the former fields, however, must be processed by the reply processor software task to produce usable values. In particular, generating an azimuth from the monopulse reference value is discussed in Chapter 6.

The status and control information that arrives over the DR11-K channel is the key to AMPS software processing. The remainder of this chapter presents the various cases of interpretation that can exist.

3.1 AMPS States

The AMPS surveillance processing system can be in one of two states, running or standby. Figure 3-2 illustrates the timing and interrupt structure for a typical system run/standby period.

The running mode consists of a succession of sweeps. On each sweep an interrogation is formed and transmitted through the antenna by the hardware. The rate of transmission is known as the PRF of the system, and the time period between interrogations is the sweep interval. The sweep consists of, in order of occurrence, an interrogation, a short dead time, the start of a listening period, the end of a listening period, and more dead time until the next interrogation. Figure 3-3 describes a typical sweep period. During the run mode, the 11/55 interface driver each sweep services the range gate close interrupt and activates the waiting software reply processor to initiate work on the reply data for that sweep.

MSB
15

LSB
0

| | | | | | | | | | | |
|--|--|----------|-----|-------------------------|---|---------------------------------|-----|-----|---|---|
| RANGE LSB = 60.4 ns | | | | | | | | | | |
| CODE A ₄ A ₂ A ₁ B ₄ B ₂ B ₁ C ₄ C ₂ C ₁ D ₄ D ₂ D ₁ F ₁ F ₂ X SPI | | | | | | | | | | |
| BORESIGHT AZIMUTH 14 BIT LSB = 0.022° | | | | | | | | 0 0 | | |
| CODE CONFIDENCE 1 = HI CONFIDENCE | | | | | | | | | | |
| 15 | | 12 | | 11 | | 5 | | 4 | 3 | 0 |
| MODE | | NOT USED | | | | (1) | (2) | | | |
| A, C or 2 | | | | | | | | | | |
| 15 | | 12 | | 11 | | 8 | | 7 | | 0 |
| NOT USED | | (3) | | | | FINAL MONOPULSE REFERENCE VALUE | | | | |
| 15 | | 11 | | 10 | 9 | 8 | | | | 0 |
| NOT USED | | (4) | (5) | SPECIAL MONOPULSE CHECK | | | | | | |
| 15 | | 12 | | 11 | | TOTAL MONOPULSE ACCUMULATION | | | | 0 |
| NO. OF PULSES | | | | | | | | | | |

- NOTES:**
- (1) Test Bit if reply is from test target.
 - (2) Hardware decoder register (1 of 4).
 - (3) N>2 - number of confirming monopulse samples.
Reference Pulse - F1 or F2.
Sidelobe status of reference pulse.
SPI presence.
 - (4) Hardware decoder overload bit.
 - (5) Sweep header bit.

Fig. 3-1. Reply Message from AMPS Hardware.

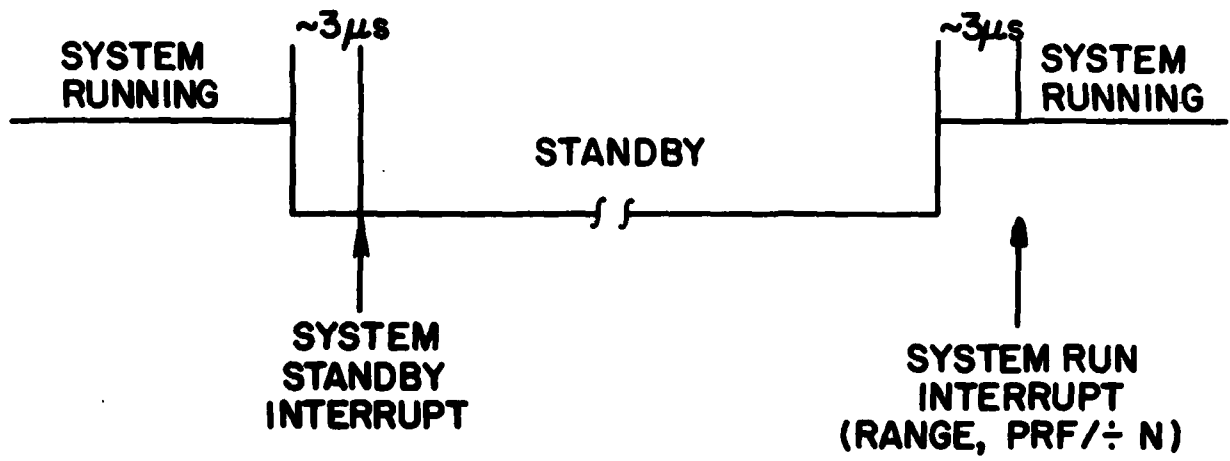
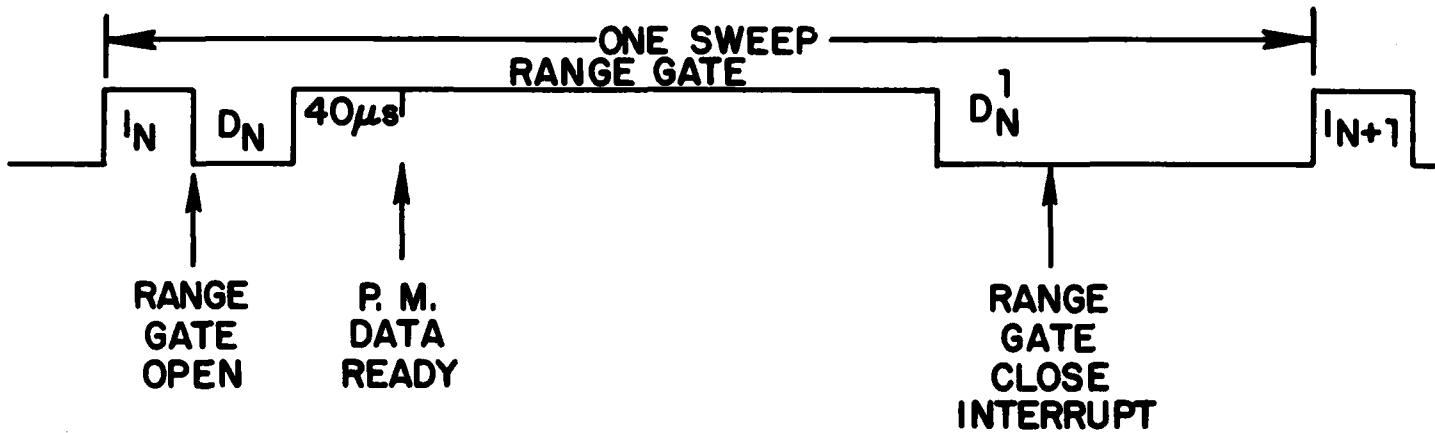

Fig. 3-2. System Run/Standby Period.



where: I_N is the interrogation window for sweep N
 D_N is the dead time to switch over to receive mode
Range Gate Open occurs when the receiver begins to listen and take in the pulses from replies. The listening period lasts until all replies from the system specified range have had time to arrive.
Range Gate Close Interrupt is a signal which occurs somewhat after the range gate shuts down. This is the interrupt which begins the surveillance processing software.
 D_N^1 is the dead time remaining in the sweep interval during which the software in the 11/55 can work on the replies for the sweep and/or clean up any unfinished business in other subtasks.
P.M. Data Ready means that for some particular sweeps in a scan there are additional pieces of information passed by the hardware concerning performance monitor characteristics.

Fig. 3-3. Sweep Period.

During a standby period the AMPS hardware inhibits replies from entering the processing computer. This time may be used to change either or both of two run-time parameters, the system range and the PRF. The changing of these parameters is discussed in 11.2.1. When AMPS is running with its own transmitter in the internal (INT) mode, the PRF is set directly by a front panel setting and any integer value is permissible. On the other hand, when the AMPS system is in the external (EXT) mode and is slaved to an ATC transmitter which puts out a very high (master) PRF, a step down procedure is employed to produce the desired lower AMPS PRF. The divide-by-N "(+N)" switch setting referred to in Fig. 3-2 specifies the divisor of the Master PRF which produces the Slave PRF at which the AMPS system is run. In this case only certain few PRF values are possible, namely 1/2 the Master, 1/3 the Master, etc. The AMPS hardware in this case only processes every second, or third, etc. sweep's replies. The divide-by-N value must thus ensure that both modes A and C are active. For example, if the Master interlace is ACAC..., a value of 2 or 4 would eliminate an entire mode, so a setting of 3 is mandatory.

3.2 Computer Status Interface

The computer status circuit board in the hardware generates an interrupt, when appropriate, to the computer via the DEC DR11-K interface. This circuit board also generates a 16-bit status word which identifies the condition causing the interrupt, and which contains performance data that may or may not be valid depending on the subsystem operating mode. In response to the interrupt, the computer accepts the status word, implements the necessary actions associated with the interrupt, and processes any valid data contained in the word.

The operating conditions under which an interrupt is issued to the computer by this circuit board are:

- range gate closed,
- system standby, and
- system run.

In the 16-bit word used to specify the cause of interrupt to the computer, the most significant four bits are flags which are associated with the computer interrupt, while the remaining portion of the word is composed of data bits. Three of the flag bits identify the operating conditions causing the interrupt, while the fourth specifies either the validity of the performance monitor data or whether the system parameters contained in the word are for the INT or EXT mode. Figure 3-4 shows the format of a status word and identifies all permissible flag combinations that may appear in the flag field portion of the word.

3.2.1 Range Gate Closed Condition

The most common cause of a computer interrupt is the range gate closed condition. An interrupt caused by this condition indicates to the computer that:

WORD BIT ASSIGNMENT

| | | | | | | | | | | | | | | | |
|---------|----|----|----|------|----|---|---|---|---|---|---|---|---|---|---|
| 15 | 14 | 13 | 12 | 11 | 10 | 9 | 8 | 7 | 6 | 5 | 4 | 3 | 2 | 1 | 0 |
| . FLAGS | | | | DATA | | | | | | | | | | | |

PERMISSIBLE FLAG COMBINATIONS

| 15 | 14 | 13 | 12 | FLAG TYPE |
|----|----|----|----|---|
| 1 | 0 | 0 | 0 | Range gate closed, PM data not provided |
| 0 | 1 | 0 | 0 | System standby |
| 0 | 0 | 1 | 0 | System run, INT system parameter data provided (range, PRF) |
| 0 | 0 | 1 | 1 | System run, EXT system parameter data provided (range, + N) |
| 1 | 0 | 0 | 1 | Range gate closed, PM data provided |
| 1 | 1 | 0 | 0 | Range Gate closed, system standby occurred when range gate was open, PM data not provided |
| 1 | 1 | 0 | 1 | Range gate closed, system standby occurred when range gate was open, PM data are provided |

PM - Performance Monitor
 INT - Internal Operating Mode
 EXT - External Operating Mode

Fig. 3-4. Status Word Format

- a. the range gate has closed,
- b. the reply processing performed by AMPS has been completed and all processed data has been delivered to the computer via the DR11-B,
- c. the computer may start processing the data which it has received, and
- d. the computer must reinitialize in preparation for the opening of the next range gate.

In the word transferred to the computer caused by a range gate closed condition, the system standby and/or performance monitor data flag bits may be set in addition to the range gate closed flag bit. A word containing only the range gate closed interrupt flag in the set condition indicates to the computer that the computer should proceed with its normal operating procedure following a range gate closing, i.e., begin processing the received reply data and prepare for the next range gate opening. Also, the absence of a PM data flag in the word indicates to the computer that the data content of the word is not valid.

A word containing both the range gate closed and the system standby flags indicates that the system went into standby while the range gate was open. The setting of these two flags indicates to the computer that the computer should not proceed with its normal operating procedure following the closure of this range gate, but it should set the system into the standby operating condition (see 3.2.2).

The presence of a performance monitor (PM) data flag indicates that the 12 data bits of the word contain valid PM data. Performance monitor data, if available, is delivered to the computer status circuit board at approximately 40 microseconds after the opening of the range gate. The data bits latched in the buffer then are included in the data field of the word when the word transfer occurs.

3.2.2 System Standby Condition

The system standby condition interrupt occurs when the AMPS state switch is changed to STANDBY from either EXT or INT. The computer, upon receiving the associated status word, proceeds to terminate its surveillance operation.

This termination procedure occurs by normal sweep processing. During standby, range gate close interrupts continue to occur, but no reply data is processed. Thus, no target reports are created and all tracks eventually coast into a drop state. Thus, after several scans of this process the software has returned itself and all data structures to the initial state. At this point, new range or PRF parameters can be accepted, and operation re-started when standby is ended.

Should the switch be returned to INT or EXT before the software termination has concluded, the state change recognition must be delayed. This is due to the errors that would occur if new parameters were used while old data bases (built via the old settings) still existed. The software reply processing task is responsible for ensuring this delay by insisting that a minimum number of range gate close interrupts occur after start of standby before new parameter values or replies be permitted in the surveillance system.

3.2.3 System Run Condition

The system run condition interrupt occurs when AMPS is placed in either the external (EXT) or internal (INT) operating mode from standby. The computer, upon receiving the associated status word, returns to the processing of reply data (subject to the above delay constraint).

3.2.4 Contents of the Data Field

The data field of the status word contains either data from the performance monitor or system run data. This data is received by the computer status circuit board and fed to an array of two-input multiplexers which select those data values that are consistent with the system operating mode and the flag contents of the status word. Two of the multiplexers are controlled by the internal operating mode line. When AMPS is in the internal operating mode, the PRF value appears at the output of these multiplexers. When AMPS is in the external operating mode, the divide-by-N (+N) value appears at the output of the multiplexers.

The outputs of these two multiplexers serve as inputs to another pair of two-input multiplexers which are controlled by the system run pulse. The other inputs to this pair of multiplexers contain performance monitor data. The system run pulse also controls a third two-input multiplexer. One input to this multiplexer contains performance monitor data while the other input contains the range parameter value.

The outputs of these three multiplexers are delivered to three buffers which latch the data so that these data values may be transferred to the computer as part of the status word. The data consists of range and PRF values if the system is entering the internal operating mode, or range and divide-by-N values if the system is entering the external mode. At all other times, performance monitor data appears in the status word. The detailed bit assignment in a status word containing performance monitor data is shown in Fig. 3-5, while the detailed bit assignment for system parameter data is shown in Fig. 3-6.

WORD BIT ASSIGNMENT

| | | | | | | | | | | | | | | | |
|----|----|----|----|---------|----|---|---|------|---|---|---|---|---|---|---|
| 15 | 14 | 13 | 12 | 11 | 10 | 9 | 8 | 7 | 6 | 5 | 4 | 3 | 2 | 1 | 0 |
| 1 | X | 0 | 1 | DATA ID | | | | DATA | | | | | | | |

X = 0 or 1

ID = identification

| DATA ID | DATA TYPE |
|---------|---------------------------------|
| 0 0 0 1 | P_1 |
| 0 0 1 0 | P_2 |
| 0 0 1 1 | Σ |
| 0 1 0 0 | Ω |
| 0 1 0 1 | $\Delta/\Sigma, \Delta=0$ |
| 0 1 1 0 | $\Delta/\Sigma, \Delta=+\Sigma$ |
| 0 1 1 1 | $\Delta/\Sigma, \Delta=-\Sigma$ |
| 1 0 0 0 | Ω noise |
| 1 0 0 1 | Σ noise |
| 1 0 1 0 | First error word |
| 1 0 1 1 | Second error word |

Fig. 3-5. Performance Monitor Data.

FIRST ERROR WORD BIT ASSIGNMENT

| | | | | | | | | | | | | | | | |
|----|----|----|----|----|----|---|---|---|---|---|---|---|---|---|---|
| 15 | 14 | 13 | 12 | 11 | 10 | 9 | 8 | 7 | 6 | 5 | 4 | 3 | 2 | 1 | 0 |
| 1 | X | 0 | 1 | 1 | 0 | 1 | 0 | H | G | F | E | D | C | B | A |

SECOND ERROR WORD BIT ASSIGNMENT

| | | | | | | | | | | | | | | | |
|----|----|----|----|----|----|---|---|---|---|---|---|---|---|---|---|
| 15 | 14 | 13 | 12 | 11 | 10 | 9 | 8 | 7 | 6 | 5 | 4 | 3 | 2 | 1 | 0 |
| 1 | X | 0 | 1 | 1 | 0 | 1 | 1 | X | X | N | M | L | K | J | I |

X = 0 or 1

| PARAMETER SYMBOL | PARAMETER TYPE | PARAMETER SYMBOL | PARAMETER TYPE |
|------------------|---------------------------------|------------------|--------------------|
| A | P_1 | I | Σ noise |
| B | P_2 | J | LO amplitude |
| C | Σ | K | LO lock |
| D | Ω | L | RF Temp - high |
| E | $\Delta/\Sigma, \Delta=+\Sigma$ | M | RF Temp - low |
| F | Ω noise | N | Az register status |
| G | $\Delta/\Sigma, \Delta=0$ | | |
| H | $\Delta/\Sigma, \Delta=-\Sigma$ | | |

NOTE: For each parameter type:

0 = normal

1 = error

Fig. 3-5. Performance Monitor Data. (Cont.)

WORD BIT ASSIGNMENTS

INTERNAL OPERATION

| 15 | 14 | 13 | 12 | 11 | 10 | 9 | 8 | 7 | 6 | 5 | 4 | 3 | 2 | 1 | 0 |
|----|----|----|----|-------|----|---|--------------|---|---|---|---|---|---|-----|---|
| 0 | 0 | 1 | 0 | RANGE | | | PRF (BINARY) | | | | | | | | |
| | | | | | | | MSB | | | | | | | LSB | |

EXTERNAL OPERATION

| 15 | 14 | 13 | 12 | 11 | 10 | 9 | 8 | 7 | 6 | 5 | 4 | 3 | 2 | 1 | 0 | |
|----|----|----|----|-------|----|---|---|-----------|-----|---|---|---|---|---|---|-----|
| 0 | 0 | 1 | 1 | RANGE | | | X | + N (BCD) | | | | | | | | |
| | | | | | | | | | MSD | | | | | | | LSD |

x = 0 or 1
LSB = least significant bit
LSD = least significant digit
MSB = most significant bit
MSD = most significant digit

RANGE BIT ASSIGNMENTS

| 11 | 10 | 9 | RANGE, NMI |
|----|----|---|------------|
| 0 | 1 | 0 | 5 |
| 0 | 0 | 1 | 10 |
| 0 | 0 | 0 | 20 |
| 1 | 1 | 0 | 50 |
| 1 | 0 | 1 | 100 |
| 1 | 0 | 0 | 200 |

Fig. 3-6. System Parameter Data.

4. SURVEILLANCE PROCESSING TASKS

Surveillance processing, consisting of four software tasks, can be divided into two large processing elements: sweep processing and sector processing. Sweep processing concerns itself with reply correlation and target declaration, while sector processing consists of track initiation, target/track correlation, track update and prediction, and surveillance data outputting. Figures 4-1 and 4-2 present flow diagrams of these elements. Ref. 2 should be consulted for a complete description, and logic diagramming of these functions.

This section summarizes the functions of these two surveillance processing elements. The four tasks that implement these elements interact with each other according to a priority structure. That is, a higher priority task, when ready to go, will always interrupt a lower priority task. Since sweep processing has no queuing mechanism, and is more seriously affected by a delay, its two tasks are assigned higher priority levels than the two tasks which comprise the sector processing functions.

The four tasks which make up the AMPS software, in order of highest priority to lowest priority, are:

A. Sweep Processing Tasks

1. Reply processor task.
2. Reply correlation task.

B. Sector Processing Tasks

1. Target/track correlation task.
2. Track update task.

4.1 Reply Processor Task

The reply processing task is executed each sweep, beginning at the range gate close interrupt (refer to Fig. 3-3). This task begins by handling the I/O from the AMPS hardware reply processor. A maximum of 128 16-bit words are transferred during this burst, consisting of eight words per reply. (The message format for a single reply was illustrated in Fig. 3-1).

Then the reply processor task completes the reply declaration process started by the hardware by searching for and eliminating replies that are thought to have been caused by one of the following:

- Sidelobe interference.
- A military identification response.
- An out-of-spec (wide pulse) transponder.
- An aircraft beyond the range limit for the sector (see Chapter 5).

Finally, the remaining replies have their range and azimuth estimates computed by the software using the time and monopulse information provided by the hardware.

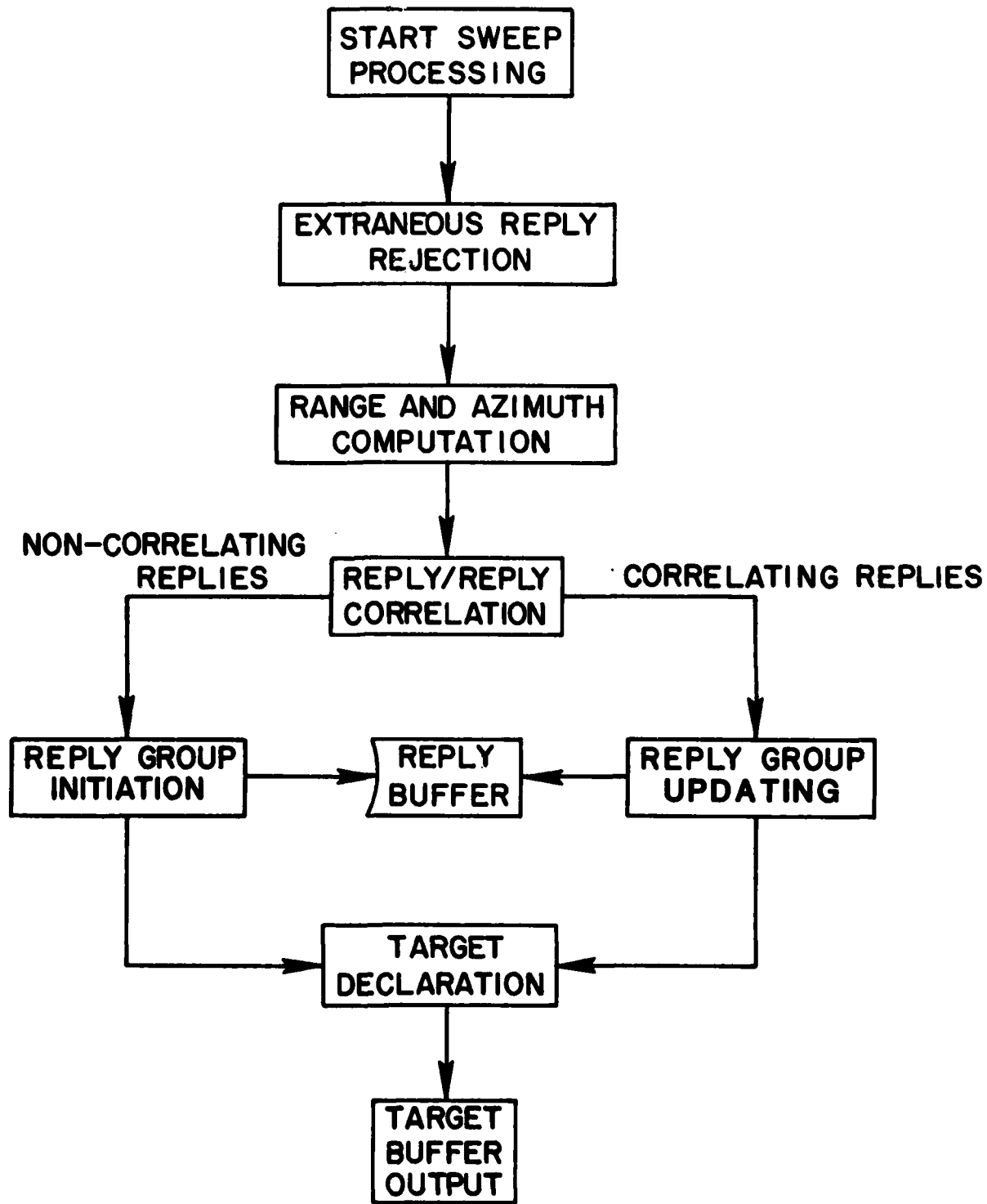

Fig. 4-1. Sweep Processing.

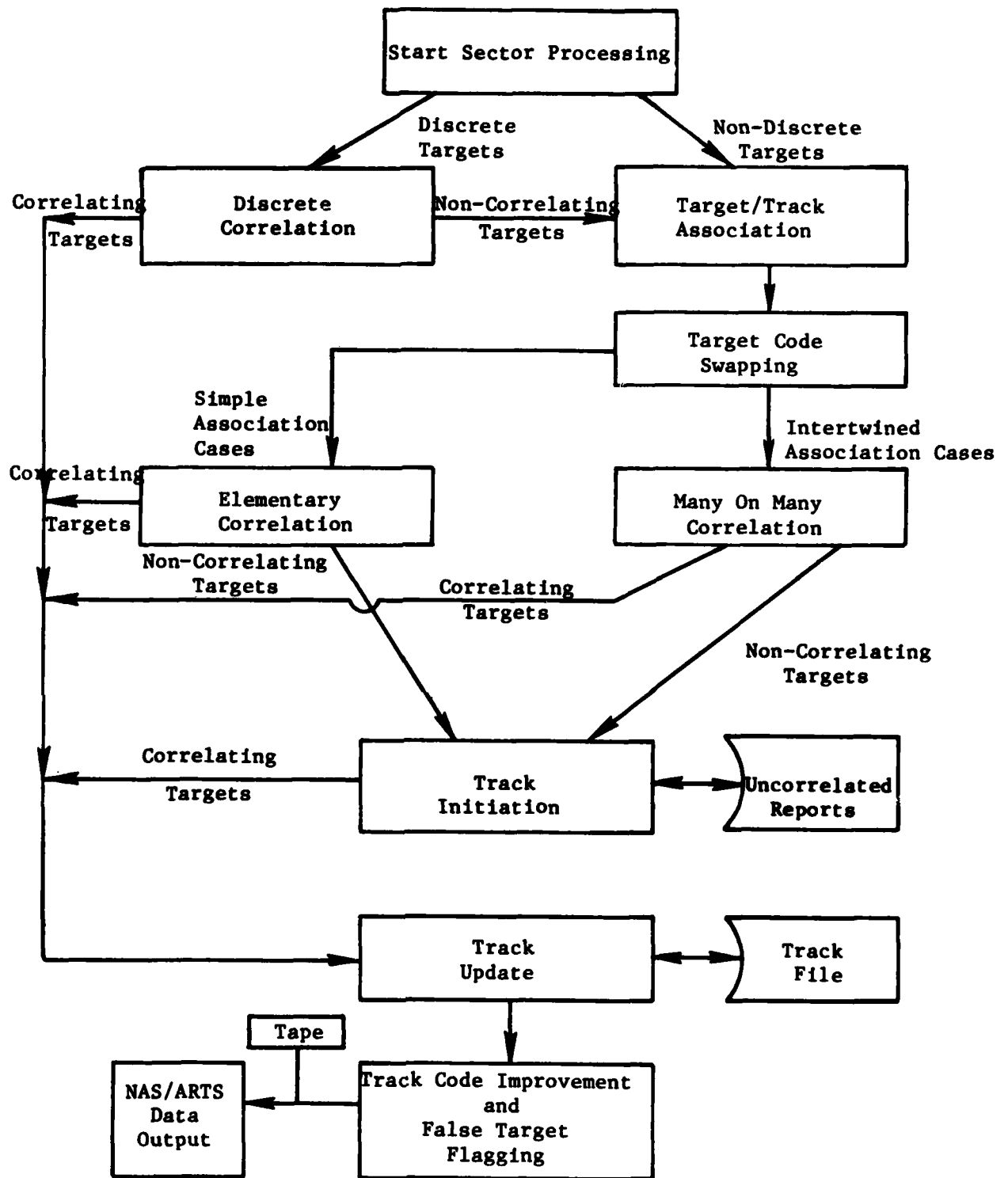

Fig. 4-2. Sector Processing.

4.2 Reply Correlation Task

This task, also executed once per sweep, attempts to correlate the replies presented to it by the reply processor task. This search is aided by a reply sort table, which permits identification by range of all existing reply groups (either uncorrelated replies or unions of two or more correlated replies).

Each new reply is correlated with the first group found for which the following four conditions are satisfied:

- The range difference between the reply and the group is no greater than $\Delta\rho_{\max}$
- The difference between the monopulse azimuth estimates is no greater than $\Delta\theta_{\max}$
- The group has not already correlated with another reply from the current sweep
- The code of the reply agrees with that of the group.

If a successful match is obtained, the new reply attributes are combined with those of the existing reply group to produce an updated group specification. Otherwise, the reply is sorted into the range sort table and becomes available for correlation with future sweep replies.

After all replies from the current sweep have been processed, reply groups that are known to be complete, based on the number of sweeps that have occurred since the oldest reply contained within them, are converted into raw target reports. As part of this conversion, the mode C code is translated into altitude flight level. These reports are collected in a buffer, and once per sector are passed as input to the sector processing tasks.

4.3 Target/Track Correlation Task

This task processes, once per sector, the target buffer prepared by the reply correlation task. Its main functions are described below.

4.3.1 Discrete Code Correlation

The ATCRBS system employs two types of identity codes, discrete and non-discrete. Discrete codes are assigned uniquely to aircraft within a single control area, while non-discrete codes can be used by all aircraft in the same flight class (such as all VFR). Thus, agreement in mode A code between a discrete target report and a track is generally sufficient for target-to-track correlation, while more complex criteria are required to correlate non-discrete targets and tracks.

All ATCRBS track data, for both discrete and non-discrete tracks, are physically located in the same track file. However, a separate hash coded table permits all discrete code tracks to be accessed through their code.

Thus, whenever a discrete code target report is to be correlated, it is possible to determine whether or not a track possessing the same code currently exists.

A target report and a track having the same discrete code are correlated whenever both of the following conditions are met:

- Only one track exists with that code (assignment failure or tracking errors could produce duplication),
- The target and track associate in range, azimuth, and altitude.

Only target reports that possess no low confidence code bits are considered discrete; reports with discrete codes that have some uncertainty must be treated as non-discrete reports.

4.3.2 Target-to-Track Association

The first step in correlating non-discrete target reports, or discrete reports not successfully correlating as above, is to determine all possible pairs of target and track associations. From these pairs, the best correlations will be selected in the manner described in the next subsection. As part of the association process, many reply correlation and reply processor errors will be corrected through a process called code swapping.

As a minimum condition for association, a target report and a track must lie close together in range and azimuth. Three association zones are defined around each track for this test. These zones, denoted by 1, 2 and 3, correspond to expected prediction errors for aircraft flying straight, turning, and maneuvering in an unusual manner respectively.

In addition, code and altitude compatibility are checked for each potential association pair. If both modes agree, the association is accepted, while if neither mode agrees, the association is rejected. Zone 1 or 2 situations in which only one mode agreement exists are processed by the code swapping algorithm, which identifies and corrects cases of improper mode pairing by the reply processor.

Finally, if any accepted association pair is suspect, either by being in zone 3 or in zone 2 with a mode disagreement, a velocity reasonableness test is made. This test rejects all associations in which it is physically impossible for the aircraft under track to be located at the target report position.

4.3.3 Target-to-Track Correlation

Once all the target/track association pairs have been identified for a sector, a determination of the "correct" target report for each existing track must be made. Two types of scoring mechanisms are employed in this procedure to rank the various pairings: the Quality Score and the Deviation Score.

The Quality Score for a target-to-track association measures the degree to which the characteristics of the target report match those of the track, as well as the degree of certainty as to the validity of the report and track (that is, that they correspond to real aircraft and not system errors). The decision items that constitute this score, in order of decreasing importance, are the following:

- Association zone (1, 2, or 3)
- Mode A code agreement
- Number of replies in the report
- Mode A confidence of the report
- Mode C altitude agreement
- Track validity

The Quality Score is computed by evaluating where the target and track attributes fall on the scale of values defined for each item, and then weighing and summing these individual scores. The lower the resulting score, the better the association.

The Deviation Score for an association measures the detailed geometrical relationship between the target and track positions. Both the magnitude and direction of their difference is considered. Due to the complexity of these calculations, the Deviation Score is employed only when the Quality Score utilization results in a tie between two association pairs.

The algorithm for determining the best associating target report for a track depends upon the complexity of the associative system linkages. If one track and one report associate only with each other, that report is selected. If several reports associate only with one track, the report with the lowest Quality Score is selected. In case of a tie, the Deviation Scores are employed as tiebreakers. An analogous dual rule is used when several tracks associate only with one report. Finally, when a many-track-many-report associative system exists, the pairings that minimize the sum of the selected Quality Scores are chosen. The algorithm that performs these selections is a best first approximation to the optimum solution of a well known decision technique, called the Assignment Problem.

4.4 Track Update Task

This task follows the target/track correlation task and completes the sector processing functions. Its main functions are described below:

4.4.1 Track Initiation

A new ATRBS track is initiated whenever uncorrelated target reports are found on two successive scans that appear to have been generated by the same aircraft. The criteria that are employed in making this judgment are that the two reports:

- Be sufficiently near each other that a real aircraft could traverse the distance in one scan
- Agree in identity code
- Be close together in altitude

Whenever two reports are found that satisfy these conditions, a new track file entry is created and placed on the list for the current sector. In addition, if the identity code of the track is discrete, the track is entered into the discrete track hash code table to permit future discrete code correlations.

4.4.2 Track Update

After the target to track correlation process has been completed for a sector, all tracks which have had their correlation resolved, either successfully or unsuccessfully, are predicted forward to the next scan. All tracks initiated during the current sector are automatically predicted ahead.

Tracks that possess correlating target reports, including newly initiated tracks (whose correlating report is the one that led to its formation), go through a two-step range and azimuth updating procedure. First, the current predicted position and velocity are adjusted to reflect the location of the correlating target report. For a general α , β tracker, this smoothing would be a compromise between the prediction and the data point positions. The ATCRBS system, however, employs a 2-point tracker. This means that the smoothed position becomes that of the correlating report and the smoothed velocity is determined totally by the last two such reports. After the track is smoothed, the new velocity estimate is used to predict the track position ahead one scan.

The identity code and altitude fields of a correlated track file are also updated each scan. In general, the target code will agree with that of the track, so no code modification action is required. However, if the track is initiated in garble, several scans may be required to construct the entire code. Also, the code of an aircraft could change from time to time due to controller direction. The altitude update simply keeps the most current altitude of the aircraft in the track file.

Tracks that fail to correlate must also be updated, although the procedure is somewhat different. First, if the track has failed to correlate for a specified number of consecutive scans, it is dropped. An exception to this rule is made whenever the track is passing through the cone of silence of the sensor. In addition, since no report is present, no smoothing of the track position, nor identity code or altitude update of the track, can be made. The mechanism used to predict ahead a coasted track is identical to that for a correlated track.

4.4.3 False Alarm Target Reports

Not every raw target report created by the reply correlation process corresponds to a real aircraft position. Several inherent properties of the

ATCRBS system will produce various types of false alarm target reports. To the extent possible, the surveillance processing subsystem attempts to identify and eliminate these reports.

The four types of false alarm reports specifically handled by the software are:

- False targets - produced by replies bouncing off reflecting surfaces
- Fruit targets - produced when fruit replies coincidentally correlate
- Split targets - produced by the failure of reply correlation to group together all replies emanating from an aircraft
- Ringaround targets - produced by sidelobe replies which were not suppressed

When any of these reports are identified, the system will take the action specified by the user. The alternatives he can choose are: (1) immediate elimination of the reports, (2) marking the reports and not allowing them to be used in correlation or track initiation, or (3) marking the reports but otherwise processing them in the normal manner. If the third alternative is selected, any tracks initiated by false-alarm reports will also be marked as false.

The most serious false-alarm targets are those caused by the reflection of aircraft responses from buildings, hangars, or other structures near the sensor, thereby causing an apparent aircraft position behind the reflector. Depending upon the size of the reflector, such false targets may persist for several scans and initiate false tracks. Fortunately, since the reflection mechanism is deterministic, it is possible to compute the position of the aircraft whose signal would be responsible for the target. Thus these false targets can be identified provided the reflecting surface parameters are known.

4.4.4 Output Reports

The primary output of any ATCRBS sensor is a stream of target reports, one per scan for each aircraft in the coverage region. In a Mode S sensor (and in the AMPS implementation of it), two types of reports exist: raw and polished. Raw reports are those declared through reply correlation. They are often incomplete in their information fields, and on occasion are due to false alarms rather than to real aircraft. Polished reports, on the other hand, have been processed through several software improvement algorithms that make use of track history information. Those reports felt to be valid are completed and labelled with a track file number, while those thought to be false alarms are discarded. In normal circumstances, only reports of the former type are output to the ATC users.

The format of AMPS output reports is dependent upon which user (display, tape, ARTS, NAS) is receiving them. Chapters 7 through 9 discuss the output processing operations.

5. INTERTASK TIMING AND CONTROL

AMPS is a real-time, event-driven, multitask system. As such, it requires an extensive structure of timing and control features to handle the task scheduling and task preemption actions. Furthermore, since AMPS will be subjected to varying degrees of processing loads, it must be able to dynamically monitor any processing overloads and adjust to them in such a way as to maintain an acceptable level of performance even in the face of heavy traffic conditions beyond its capacity.

The basic time interval in AMPS is the sweep period, which from a software viewpoint begins each time the hardware produces an interrupt signalling the availability of a new buffer of replies. As discussed in Chapter 4, both the reply processing and reply correlation tasks should execute to completion once per sweep interval. The target/track correlation and track update tasks, on the other hand, need only run once per sector. Thus they are scheduled on a time-available basis in each sweep period after the other tasks are completed. With moderate loads, enough time will exist for the sector tasks to complete their work before the next sector's data is ready.

In heavily loaded conditions, however, the sector tasks may receive little or no time per sweep period to execute, and thus fall progressively further behind. A fail-soft mechanism has been built into AMPS to prevent such system occurrences from becoming fatal. This mechanism provides two recovery procedures to limit input loading and thus permits the sector tasks to return to time synchronization. When delays are small, the active range of the sensor is reduced to decrease the load; when the delays become large, an entire sector's worth of replies is dropped. The details of these mechanisms are discussed in Section 5.2.

5.1 Task Scheduling

The basic mode of task scheduling is one in which the sweep tasks (reply processing and reply correlation) operate as foreground tasks while the sector tasks (target/track correlation and track update) operate as background tasks. Thus, one or the other of the sector tasks is always active while the sweep tasks should complete each sweep period. This timing relationship is discussed further in the next section. Various operating system directives are required to implement the details of this task scheduling procedure. The scheme described here is believed to be optimal in minimizing system overhead.

5.1.1 Reply Processing Task (Figure 5-1)

The cycle for the reply processing task begins in a WAIT state wherein the setting of event flags 16 and 17 is awaited. The event flag directives are utilized by the 11/55 executive for inter-task synchronization and signalling. When the statement "wait for event flag 1" is reached, the task is suspended until that flag is set by another task or by an I/O driver (if the flag has already been set, no delay occurs).

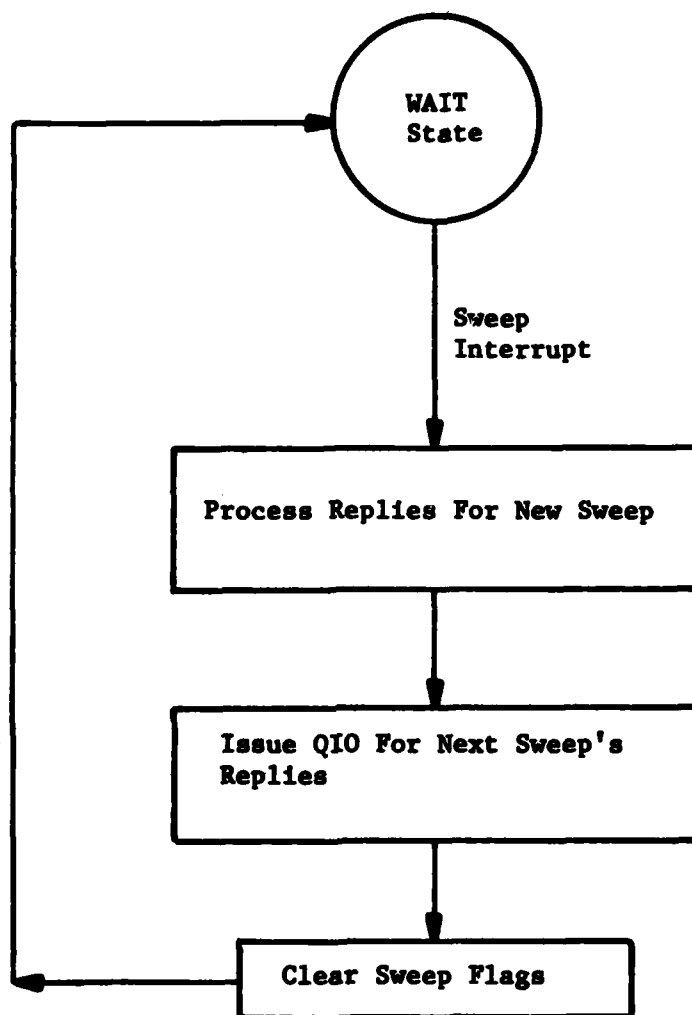

Fig. 5-1. Reply Processor Task.

Flags 16 and 17 are set by the DR11-B and DR11-K drivers respectively upon completion of the I/O transfers for a sweep. These actions are not recognized by the task scheduler, however, until an interrupt occurs (the 11/55 performs task checking only at "significant events" such as interrupts). Thus the last action of the DR11-K hardware is the generation of the range-gate-closed interrupt discussed in Chapter 3. At this occurrence, the reply processing task is re-activated. Because it has the highest priority of any task, it immediately preempts the task currently in execution.

After the processing for the new replies is completed, this task issues the QIO's for the next sweep's data. A QIO directive instructs the system to place an I/O request for a physical device (here the DR11-B and the DR11-K) in a queue for that device. The QIO structure permits asynchronous buffering of requests while program execution continues.

Finally, the task clears flags 16 and 17 and enters the WAIT state pending their subsequent setting by the completion next sweep of the open QIO requests. The next highest priority task, reply correlation, is now free to execute.

5.1.2 Reply Correlation Task (Figure 5-2)

The reply correlation task also begins its processing cycle in a WAIT state. This task is waiting for a "significant event", which for AMPS is always an interrupt. In general, the interrupt will be the range-gate-closed one just discussed. Thus the reply correlation task becomes active at exactly the same time as the reply processing one. Because of its lower priority though, it doesn't start execution until the reply processing task is completed.

Since a few other system interrupts exist, the reply correlation task first checks to see if it was awoken at the proper time. If no new sweep data exist, an extraneous activation has occurred, and the task returns to its WAIT state.

After the reply correlation task has completed its reply grouping and target declaration functions, it checks the azimuth of the new sweep to determine whether a new azimuth sector (say N) has been entered. If it has, and if the sector processing of the two earlier sector (N-2) has been completed, then the sector processing of the just completed sector (N-1) can begin. This processing is activated by issuing the directive RESUME for the target/track correlation task. This directive instructs the task scheduler to activate a task that has previously suspended itself.

Should sector processing have fallen behind and not yet have completed work on sector N-2, the initiation process is held pending that completion. Task timing is discussed further in the next section.

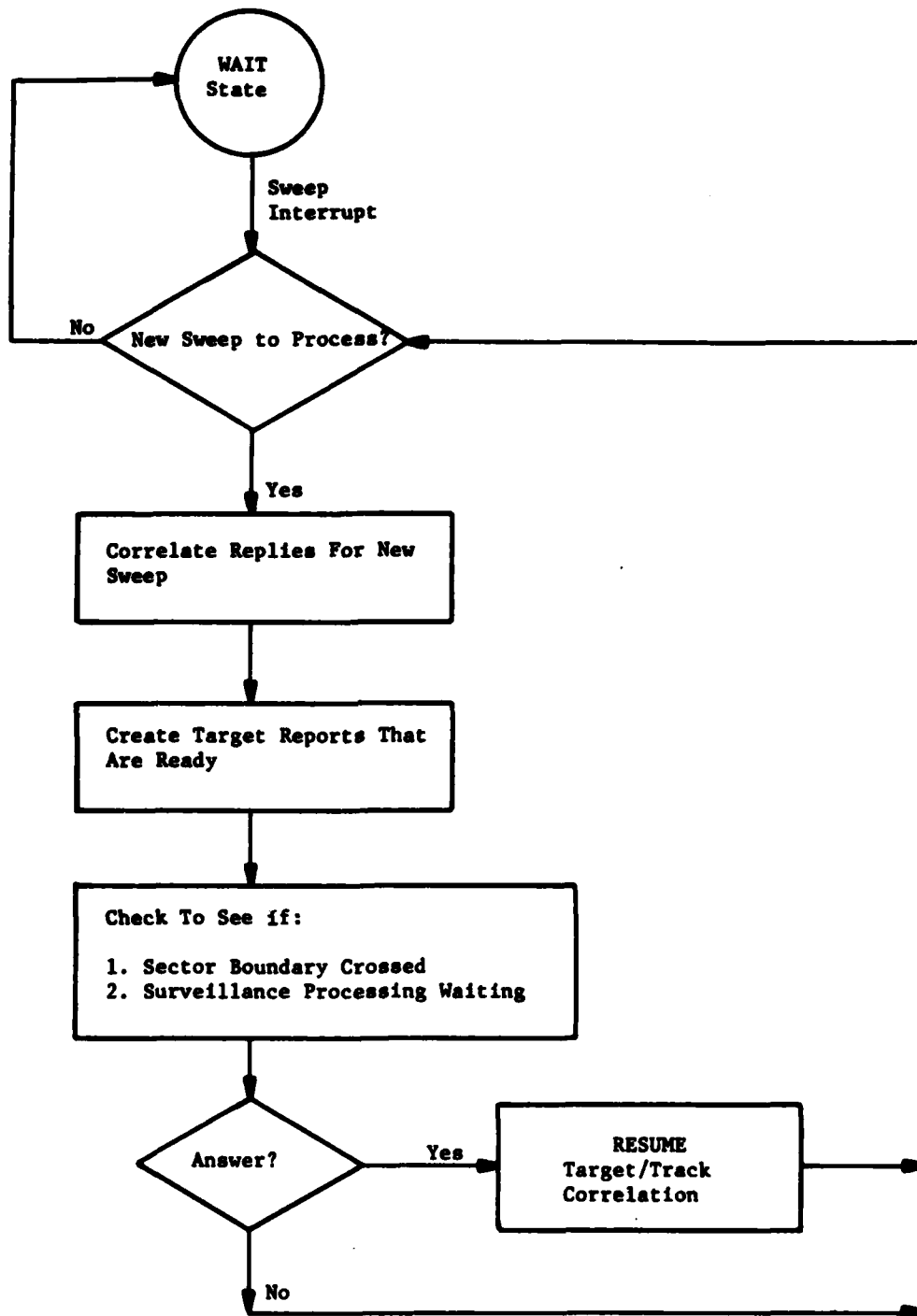

Fig. 5-2. Reply Correlation Task.

5.1.3 Target/Track Correlation Task (Figure 5-3)

The target/track correlation task is the first of the two sector processing tasks. Its cycle begins in a SUSPEND state, where it had placed itself following the completion of its functions on the previous sector. When RESUMED by reply correlation, it processes the targets for the new sector. This processing action is preempted each sweep by the higher priority reply processing and reply correlation tasks.

Upon completing its functions, this task sets to TRUE the global common variable CORRDONE, and returns itself to the SUSPEND state.

5.1.4 Track Update Task (Figure 5-4)

The track update task is the second of the two sector processing tasks. It performs its sector functions subsequent to the completion of the target/track correlation task. This completion condition is signalled by the transition to TRUE of the CORRDONE variable. Upon completion of its functions, the track update task returns this variable to FALSE. This task could now SUSPEND itself. However, much operating system overhead is saved by keeping it active in an idle loop. Since this task's priority is the lowest, idling will only occur when no other task has work to perform. As soon as CORRDONE returns to TRUE, the idling ends and processing for the next scan sector commences.

5.2 Task Timing

The sweep tasks, reply processing and reply correlation, continually group replies into target reports. These reports are buffered until an entire sector's worth have been generated. At that time, the buffer is passed to the sector processing tasks, target/track correlation and track update, for processing. Two target buffers are defined in AMPS, so that the sweep tasks can be filling one while the sector processing tasks are processing the other.

The reply correlation task monitors the antenna boresite position to ascertain when a sector has ended. Referring to Fig. 5-5, when the antenna reaches position A, all replies from any aircraft in sector N-1 are guaranteed to have been received. Thus at this point the target buffer for sector N-1 can be passed to sector processing, and these tasks can be RESUMED for their next execution cycle.

On occasion, heavy traffic densities or aircraft bunching may cause sector processing to fall behind and not be finished with its sector N-2 work when sector N-1 reports are ready. In such an event, the buffer swap must be delayed, and sector N reports added to those of sector N-1 in the same buffer. Only when sector processing finally completes can another buffer be passed to it, and the old buffer returned to sweep processing for new targets. Depending upon the amount of delay, four situations may exist:

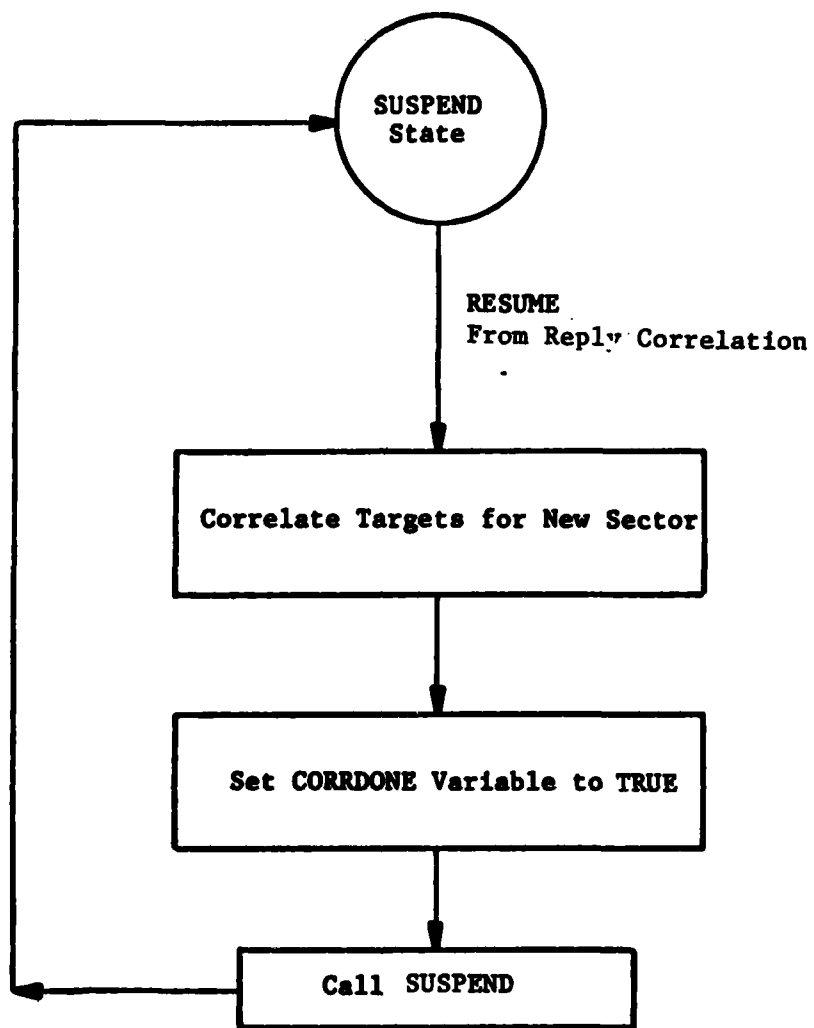

Fig. 5-3. Target/Track Correlation Task.

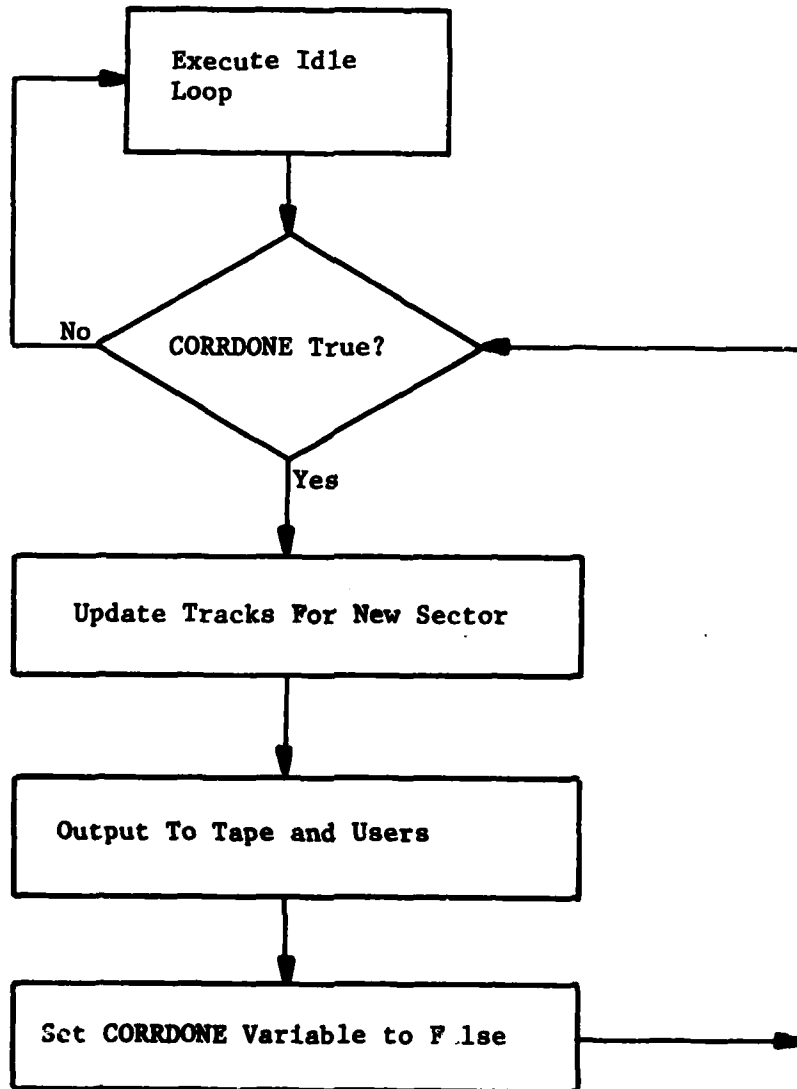

Fig. 5-4. Track Update Task.

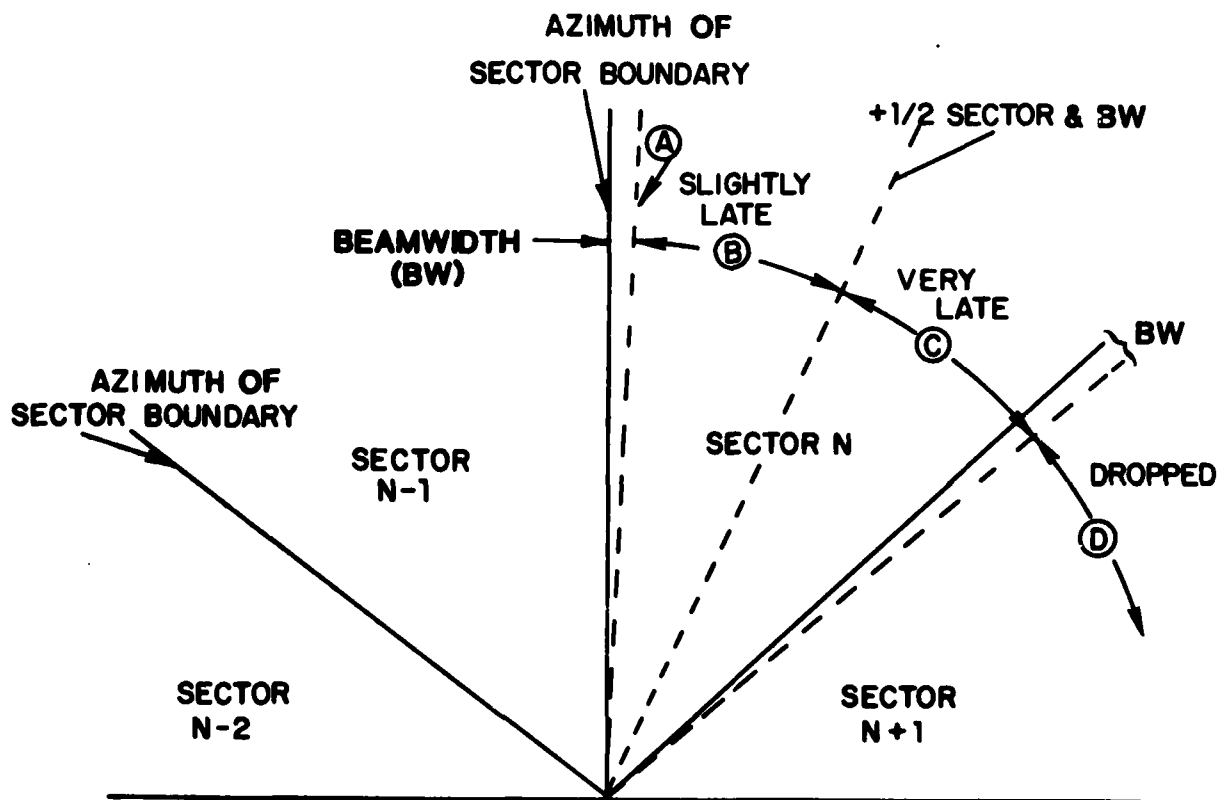

Fig. 5-5. Sector Processing Boundaries.

on time: no delay
slightly late: less than 1/2 sector delay
very late: up to a full sector delay
drop: more than a full sector delay

When either of the last two situations occur, action must be taken to return processing to time synchronization or else AMPS will soon enter an error state and halt. (Operational sensors, of course, would be designed to work under any possible load; AMPS is a test bed system.)

The scheme chosen for overcoming overloads is designed to maintain both high system throughput and time synchronization. When a very late situation is detected for the completion of sector N-1 sector processing, the active ranges for both sectors N-1 and N are decreased by 5% of full range. Thus, if the AMPS range setting is 100 miles, successive decreases will reduce the active range for the sector to 95, 90, 85, and so forth. Both sectors N-1 and N have their ranges reduced to share the penalty over the two contributing sectors: the reduction for sector N-1 creates fewer targets for sector N-1 sector processing, while the reduction for sector N creates fewer replies for sweep processing, and hence more per-sweep time for sector processing tasks during the time the sector N-1 sector processing tasks are active.

Should the processing delay deteriorate all the way to a drop situation, more drastic action is taken. In addition to the range reductions, all reports in the current target buffer are discarded and no new replies are accepted for sweep processing. This action should permit immediate return to synchronization, as no task will have data to process.

The on-time and slightly-late situations are considered normal and acceptable. Thus no correction action is required. Furthermore, if the sector range for either sector N-1 or N is at a reduced level, it is increased 5% of full range when either condition exists for sector N-1. Thus, the penalties for temporary overloads are removed as soon as the underlying cause of the problem disappears.

The remainder of this section presents timing examples that illustrate the effects and remedies of various overload situations. In each case, the processing actions for successive intersweep periods are detailed.

5.2.1 Normal Timing (Figure 5-6)

In the normal situation, both the reply processing and reply correlation tasks complete their work each sweep. Furthermore, they always leave time each sweep for sector processing to be executed. Finally, sector processing is finished, and in its idle loop, when the time for the next target buffer to be passed to it arrives. As discussed above, this time is one beamwidth beyond the end of the sector. In the simplified figure, one sweep represents a beamwidth, and thus sector processing for sector N is initiated following reply correlation for sweep 1 of sector N+1.

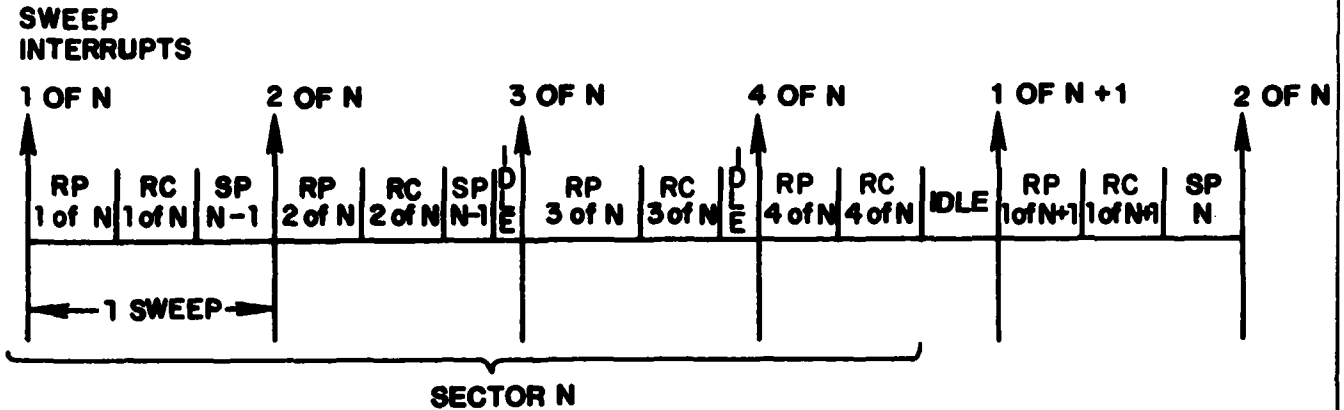

where: RP is the time needed by Reply Processing during that sweep, to process data from the hardware.

RC is the time needed by Reply Correlation during that sweep, to process data from RP.

N is the sector number in which that sweep is being processed.

SP is the time needed by Sector Processing during that sweep.

Note that SP works on data generated at least one sector earlier than the sectors worked on by RP and RC.

Idle represents the time during the sweep when there was nothing left to do.

Fig. 5-6. Typical Set of Sweeps over one Sector.

5.2.2 Reply Processor Overload (Figure 5-7)

Should a very large number of replies arrive on a sweep, reply processing may not be completed before the next sweep time. In that event, it will not have issued the QIO commands to the hardware interface. Without them, the close range gate interrupt will not be recognized, and the sweep data will be lost. In the figure, sweeps 2 and 3 of sector N are ignored and all replies lost.

When reply processing finally completes, reply correlation can begin. The large number of replies on sweep 1 also causes it to be delayed in its completion. Note that reply correlation will process all waiting replies before terminating. Thus, in the period after sweep 1 of sector N+1, it completes work on sweep 1 of N, then performs all work on replies from sweep 4 of N (2 and 3 were lost), and finally handles the newly received replies. Only then can sector processing gain time to execute.

5.2.3 Reply Correlation Overload (Figure 5-8)

In this case, the reply overload was not enough to prevent reply processing completion but was sufficient to affect reply correlation. The combination of extra work, reduced working interval, and no lost replies keeps it behind real-time for the length of the figure. Also, the increased task swapping work by the executive resulting from the reply processor preemptions of reply correlation adds to the delay. Note that sector processing never gets any time to execute.

5.2.4 Sector Processor Overload (Figure 5-9)

The final example illustrates the actions caused by sector N-2 sector processing falling so far behind that a drop category delay occurs. Reply correlation at sweep 1 of sector N+1 detects that it can now initiate surveillance processing for sector N-1, but that this action is occurring a full sector beyond the normal time. Thus, it discards all targets in the buffer, leaving the sector processing tasks for sector N-1 only overhead and track coasting actions. In addition, it tells reply processing not to process any new replies until further notice. Finally, it reduces the active ranges for both sectors N-2 and N-1.

Since sector processing for sector N-1 has so little processing to do, it may well complete immediately as shown in the figure. Then sector N sector processing can begin next sweep. It is found to be very late, but not in a drop situation. Thus, reply processing is once again permitted to function, and no more targets are discarded. The active ranges of sectors N-1 and N are reduced by 5%, however.

Finally, by sweep 1 of sector N+2, normal time synchronization has been restored.

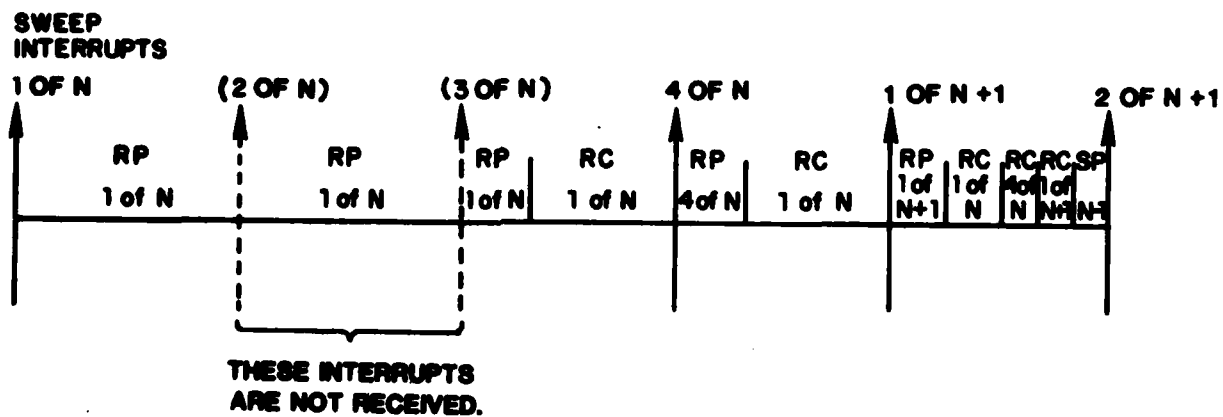

Fig. 5-7. Reply Processing Falls Behind.

**SWEEP
INTERRUPTS**

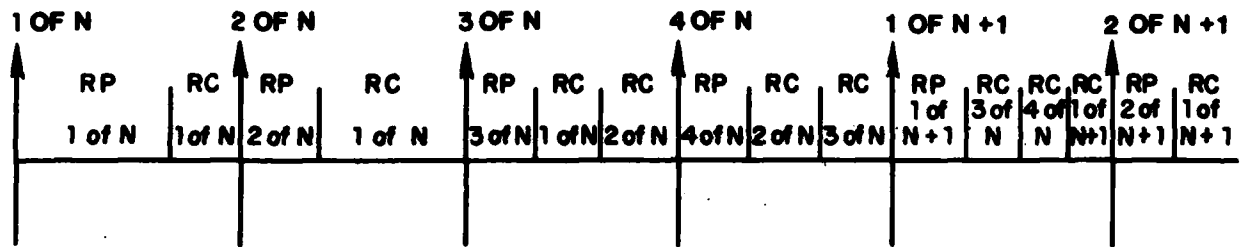

Fig. 5-8. Reply Correlation Falls Behind.

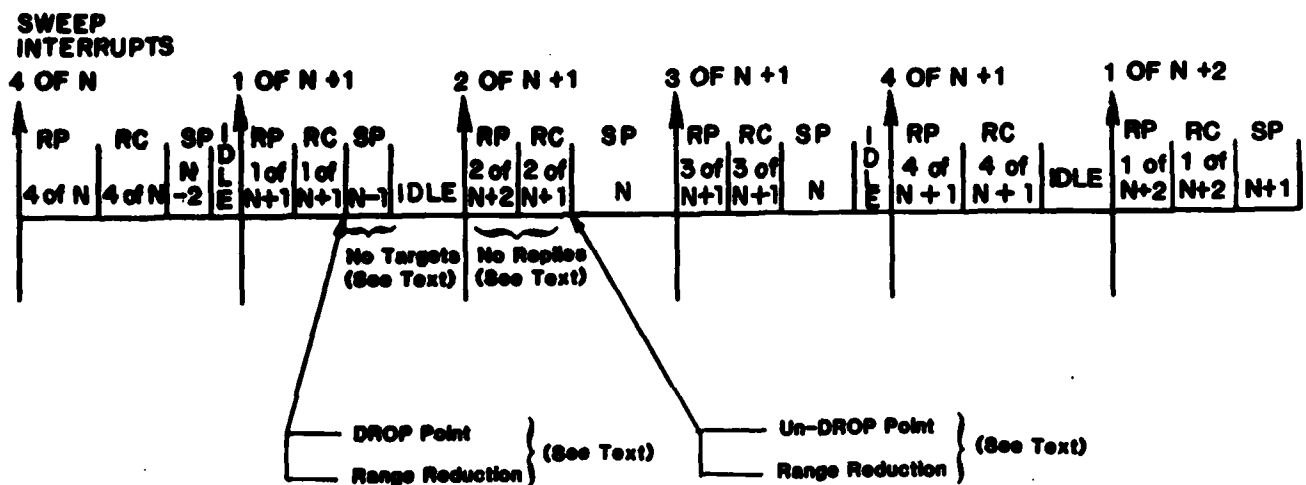

Fig. 5-9. Sector Processing Falls Behind.

6. CALIBRATION

AMPS uses monopulse processing to determine an accurate azimuthal position for its targets. Unlike the present beamsplitting technique, monopulse permits an azimuth to be determined from a single reply (actually, from each pulse in the reply). The details of this process are illustrated in Fig. 6-1. As shown there, two separate antenna patterns are employed, the sum (Σ) and the difference (Δ). The sum is a standard radar pattern, maximum power at boresite, and symmetrically dropping off in power on either side. The difference pattern, on the other hand, has a null at boresite, and grows anti-symmetrically in power with off-boresite angle, negative phase on one side and positive on the other.

From the properties of these patterns, it follows that the Δ/Σ ratio will grow from a large negative value at the left beam edge, to near zero at boresite, to a large positive value at the right beam edge. The AMPS hardware performs an A/D conversion of this Δ/Σ ratio in order to determine a value that can range over 256 monopulse reference cells. These 256 cells span the largest possible beamwidth (refer to Fig. 6-1), with cell 128 being at boresite.

In order to use a monopulse system, a calibration table is required for the particular antenna patterns being employed. This table states the azimuth correction to be added to antenna boresite for each of the 256 monopulse reference cells. Thus, for example, if the table entry for cell 164 is 0.85° , a reply received by an antenna pointing at 273.42° , whose Δ/Σ A/D cell is 164, has come from an aircraft whose true azimuth is 274.27° . This chapter describes the method of generating the monopulse correction table.

6.1 Calibration Routine

The first step of the calibration process is to establish an accurately surveyed location for a transponder which can serve as the source of the calibration replies. This source's exact range and azimuth relative to the antenna are entered into the calibration program as site parameters. The program then gathers a large number of replies from this source from which to create the correction table. For each such reply, two quantities are measured. First is the Δ/Σ A/D value produced by the reply processing hardware; this value identifies the cell for the reply. Second is the difference between the antenna boresite as reported by the shaft encoder and the surveyed azimuth of the source; this value is a sample of the true correction value for that monopulse cell. At the end of the program, an average of the samples for each cell becomes the recorded monopulse table correction value.

In order to minimize noise effects in this process, a minimum number of samples (T_1) for each cell is required. Cells receiving fewer than this number of samples have their table values generated by curve fitting as described in section 6.2. Also, cells whose samples are widely differing in value are not averaged, but are curve fit instead.

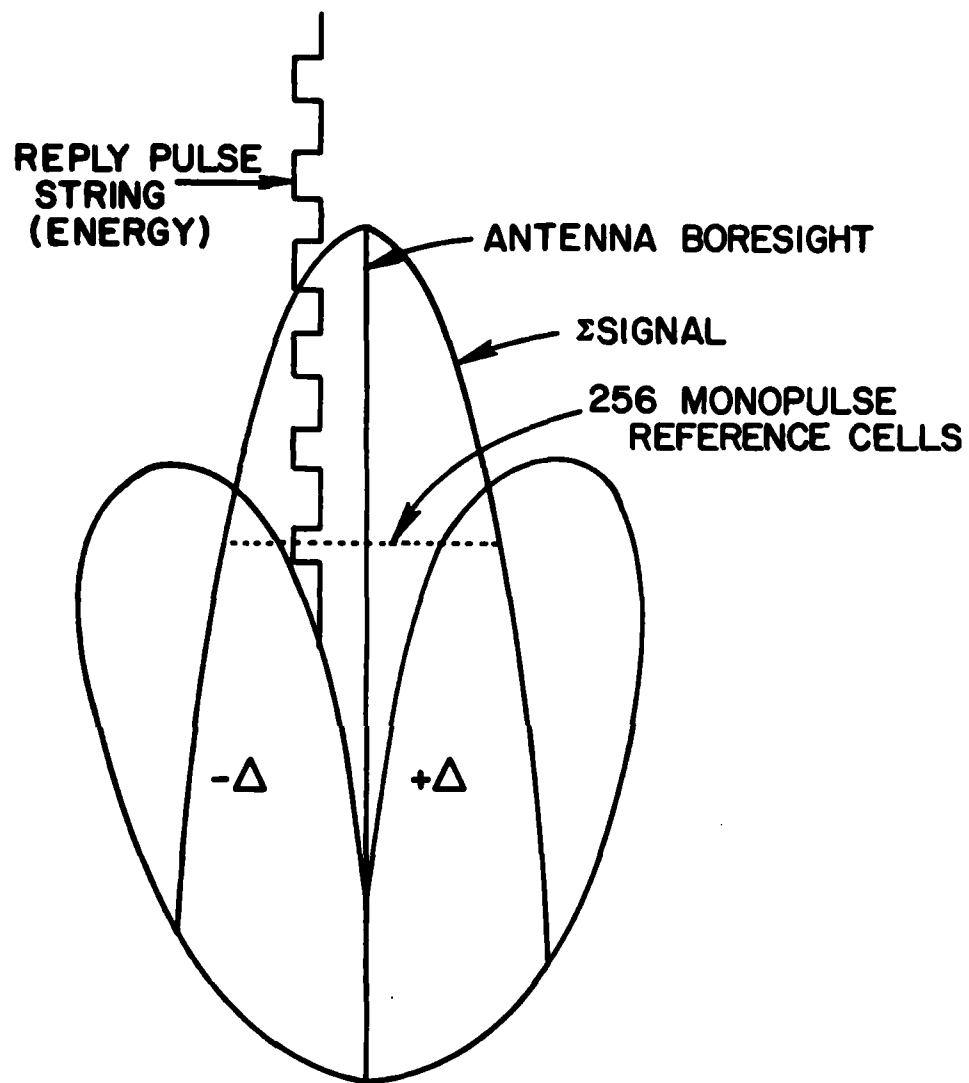

Fig. 6-1. Monopulse Antenna Beam Pattern.

The number of samples parameter T1 is determined from the length of calibration run desired by the user. In particular, the number of replies during the calibration run is given by:

$$\text{NUMCAS} = (\text{BMWDTH}/360) * \text{PRF} * \text{CALTIM} * 60$$

where:

NUMCAS is the number of replies
BMWDTH is the antenna beamwidth in degrees
PRF is the pulse repetition frequency
CALTIM is the calibration period in minutes

Then T1 is the ratio of NUMCAS to the number of cells in the active monopulse table width (not all cells from 1 to 256 will apply to a given antenna; for example, the AMPS antenna only uses cells from about 50 to 210). The active width is determined prior to the calibration run via a very short first pass of the program.

The calibration run is terminated when a sufficient fraction of the cells in the active table width have received T1 samples. This number of cells is specified by parameter T2 times the table width, and typically ranges from 1/3 to 1/2 the width. The remaining cells are then curve fit.

Figure 6-2 presents the flowchart of this calibration process. The first page shows how calibration replies are selected. Since the calibration run employs the real sensor hardware, replies from all aircraft as well as those from the calibration source are received. Thus, a range, azimuth, and code filter is required to identify source replies. In addition, all low confidence source replies are rejected, as garble often causes very noisy monopulse cell determination.

Page 2 of the figure describes the processing of the source replies. To detect noisy samples for a cell, two actions are taken. First, the first T1/2 samples for the cell are averaged, and later compared to the average of all T1 samples. If a significant difference results, all samples are erased. Second, samples beyond T1 are rejected if they differ from the current average by too great an amount. The other action on this page is setting T2, and halting when it is reached. This setting occurs when enough replies have been received to give confidence that the actual table width is known.

Finally, page 3 summarizes the actions of actually producing a monopulse correction table.

6.2 Curve Fitting Algorithm

The above calibration procedure results in a subset of the cells within the table width having their correction values set. The remaining cells are then set by smoothing these known values. The algorithm, depicted in Fig. 6-3, employs the average of two quadratic curve fits for each point to be smoothed. Each quadratic is computed so as to fit three successive known cells. This insures that every undetermined cell is covered by two successive such curves. Thus cells 58 and 59 in the figure are both covered by the two quadratics Q₁ and Q₂.

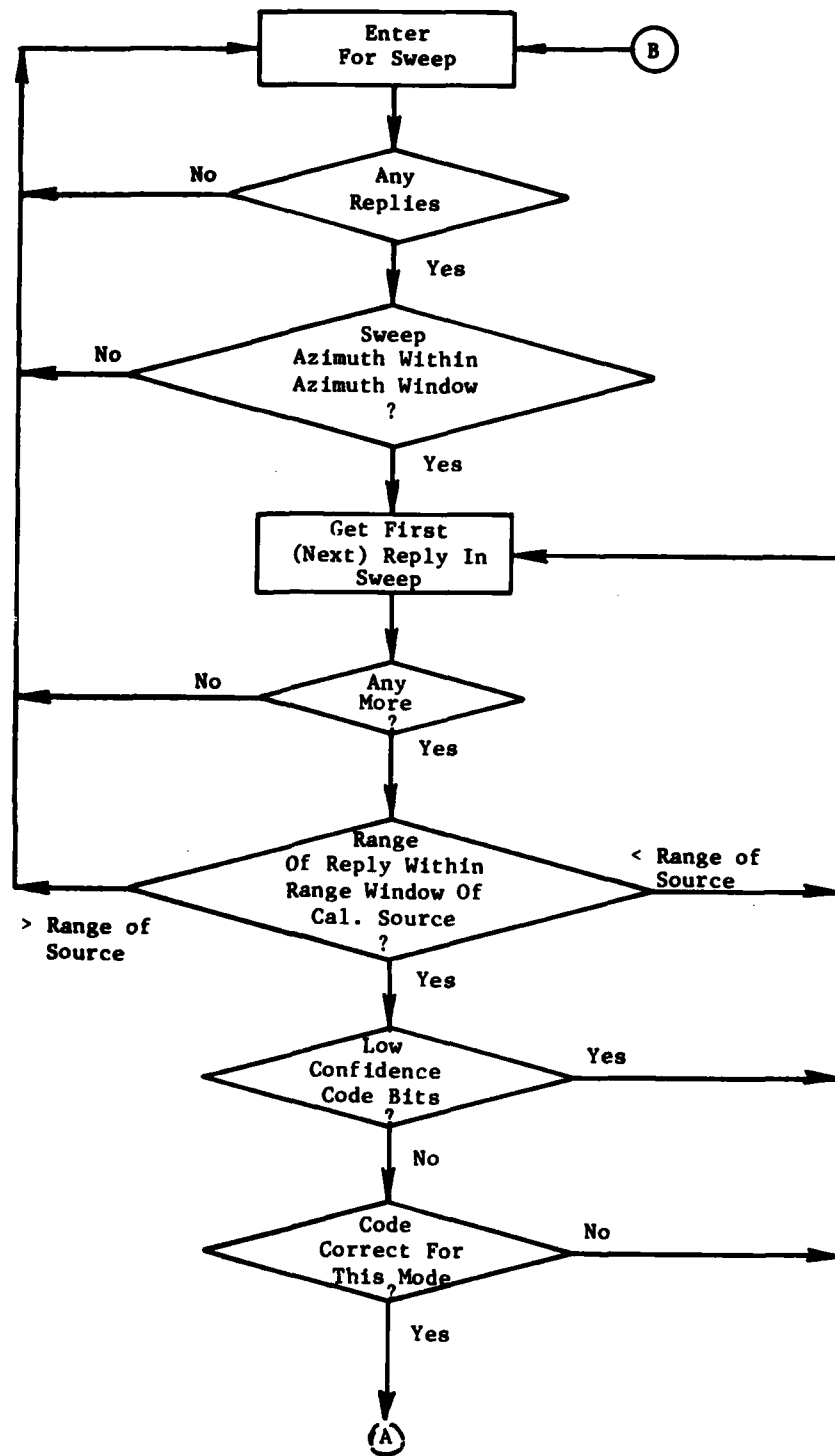

Fig. 6-2. Calibration Flow Diagram.

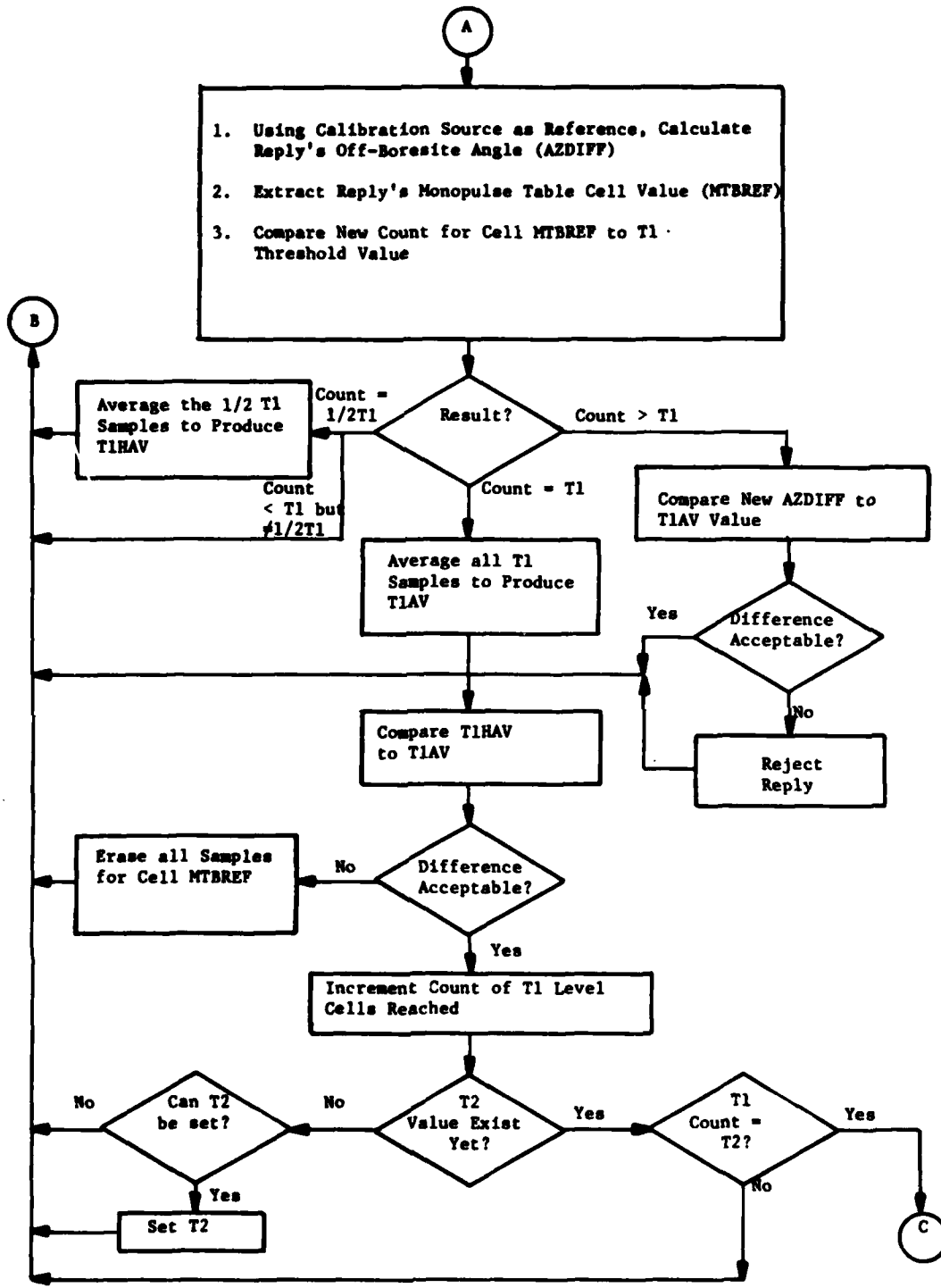

Fig. 6-2. Calibration Flow Diagram. (Cont.)

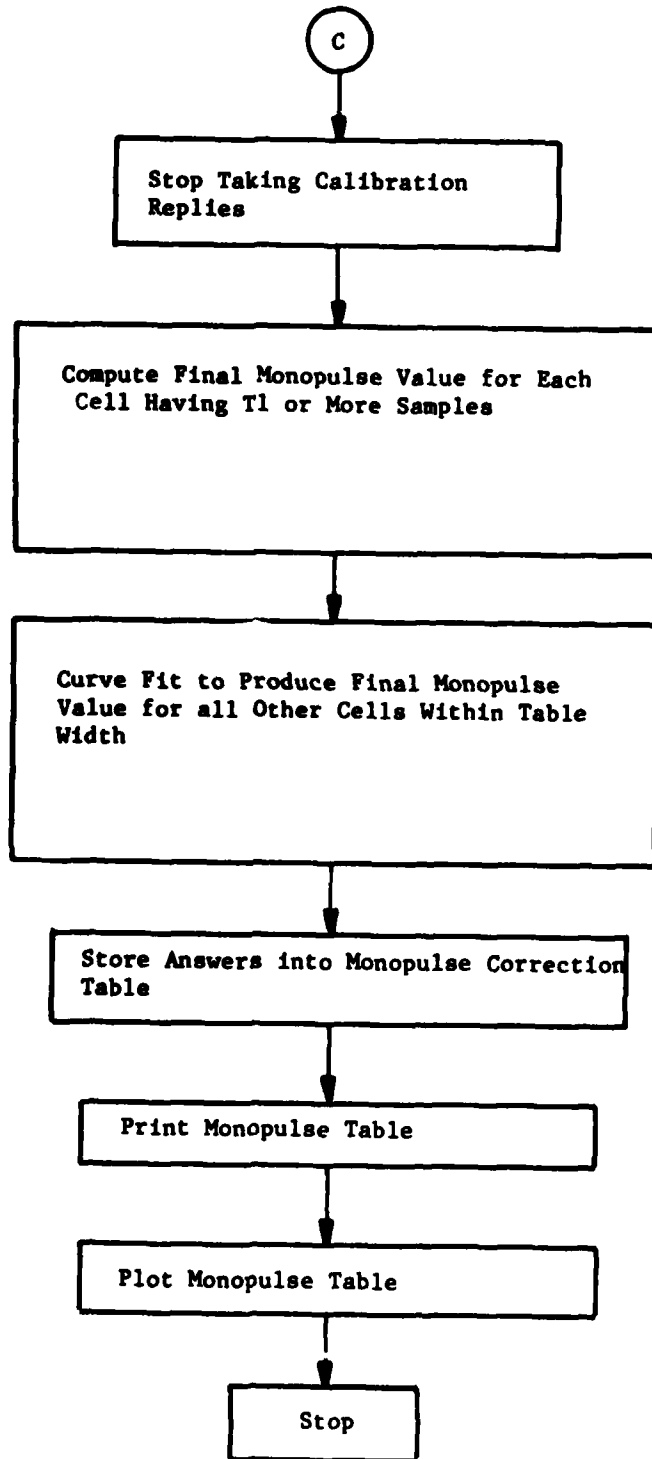
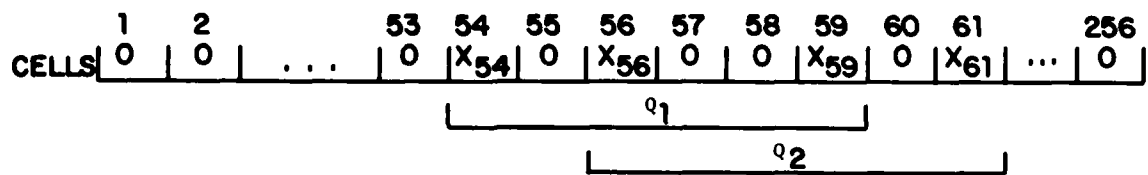

Fig. 6-2. Calibration Flow Diagram. (Cont.)

A/D COUNTS
(MONOPULSE REF. #)



0 → NO CONFIDENCE FOR THAT CELL
X_M → CONFIDENCE REACHED FOR CELL m

Fig. 6-3. Monopulse Reference Cells.

Each quadratic is of the general form:

$$Y = az^2 + bz + c$$

If we let x_1 , x_2 , and x_3 represent the three cells being fit, and y_1 , y_2 , and y_3 be their correction values, the coefficients a , b , and c can be derived as follows:

Let: $z = (x - x_2)$, $c = y_2$

Then: $y = a(x - x_2)^2 + b(x - x_2) + y_2$

$$y_1 = a(x_1 - x_2)^2 + b(x_1 - x_2) + y_2$$

$$y_3 = a(x_3 - x_2)^2 + b(x_3 - x_2) + y_2$$

Thus there are two equations in two unknowns. Solving for a :

$$y_1 (x_3 - x_2) = a(x_1 - x_2)^2 (x_3 - x_2) + b(x_1 - x_2) (x_3 - x_2) + y_2(x_3 - x_2)$$

$$y_3 (x_1 - x_2) = a(x_3 - x_2)^2 (x_1 - x_2) + b(x_3 - x_2) (x_1 - x_2) + y_2(x_1 - x_2)$$

then:

$$y_1 (x_3 - x_2) - y_3(x_1 - x_2) = a ((x_1 - x_2)^2 (x_3 - x_2) - (x_3 - x_2)^2 (x_1 - x_2)) \\ + y_2 ((x_3 - x_2) - (x_1 - x_2))$$

Let:

$$\Delta_1 = (x_1 - x_2)$$

$$\Delta_3 = (x_3 - x_2)$$

Finally:

$$a = \frac{y_1 \Delta_3 - y_3 \Delta_1 - y_2 (\Delta_3 - \Delta_1)}{\Delta_1 \Delta_3 (\Delta_1 - \Delta_3)}$$

and:

$$b = \frac{y_1 - y_2 - a\Delta_1^2}{\Delta_1}$$

Figure 6-4 depicts a segment of the overall monopulse calibration curve that results after this smoothing is performed.

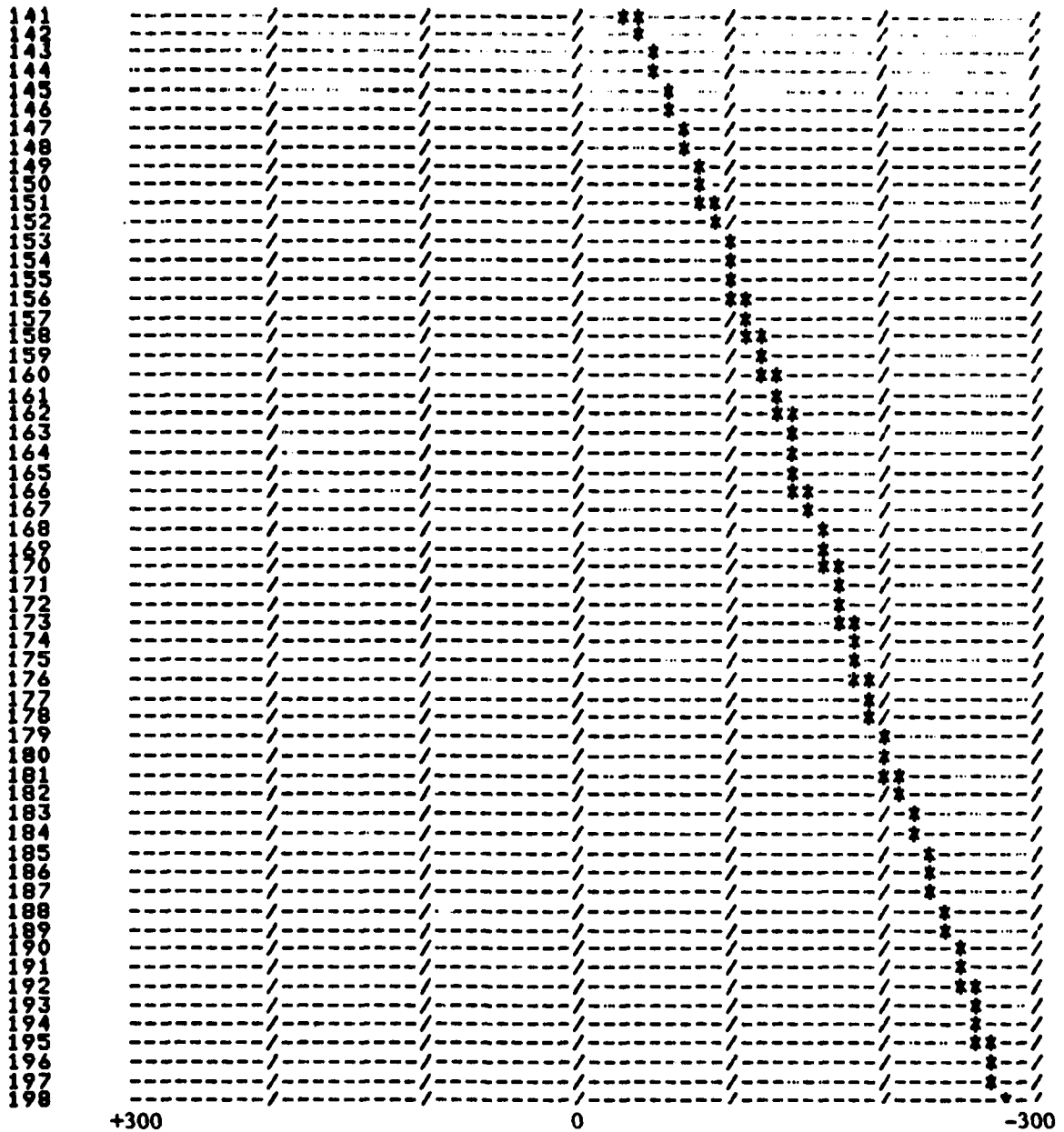

Notes:

Y-axis: Monopulse Cell Value (128=center)
 X-axis: Off-boresite correction (186 counts = 1°)
 **: True value between these positions

Fig. 6-4. Sample Monopulse Calibration Curve.

7. AMPS DATA RECORDING

Recording surveillance reports in AMPS serves two basic functions. The first is to provide a real time database on which to perform data analysis. The data analysis is of a type which provides both qualitative and quantitative information about the real traffic scenario and algorithm performance. The second function is to permit a replay of a particular real-time run or segment of a run which might be of particular interest.

The data recording is performed on a model TU10 DEC tape drive, capable of 9 track NRZI at 800 bpi. Surveillance data is recorded each sector by the track update task in a Sensor Demonstration Program (SDP) format. A data record in this format is described in Fig. 7-1. The acronyms used in this figure are:

| | |
|-------|--|
| IBLK | is a term used to identify a block of data. |
| NWDS | is the number of 32 bit words in this IBLK. |
| NRPTS | are the number of surveillance reports in this IBLK. |
| NTRKS | are the number of surveillance tracks in this IBLK. |

7.1 Parameter Blocks

The "800 + sector #" IBLK, which begins at word 21 for each record, contains run-time hardware and software measurement parameters which can change dynamically during a real-time run. There is a set of 4 such IBLKS, 801, 802, 803, 804, one for each of the first four sectors past North. The information in each of these four blocks is presented in Figs. 7-2 through 7-5.

7.2 Target Report Blocks

The format of a target report block, with notes to aid in its understanding, is presented in Fig. 7-6. A more detailed description of the special bits follows:

a. Test Target

The AMPS test target is either the CPME report, or the special internal pseudo-target.

b. Edited-out Target

Certain classes of targets may be eliminated or flagged by the AMPS surveillance processing algorithm. These classes are:

1. False targets: See c. below.
2. Fruit targets: A fruit target results when two aircraft replies sent in response to interrogations from other sensors are received at the local sensor and correlated.

| Word | ← 16 bits → | Description |
|----------------------|-----------------------|---|
| 1 | IBLK = 13 | This block contains no surveillance data. It is present only to identify a new record, or sector. |
| 2 | NWDS = 8 | |
| 16 | | |
| 17 | IBLK = 632 | These two header words identify the time that reports were begun to be put into the target buffer for the sector. |
| 18 | Sector # NWDS = 2 | |
| 19 | Time Hi | Two words of time (milliseconds) |
| 20 | Time Lo | |
| 21 | IBLK = 800 + Sector # | Header words of special system performance monitoring data recording blocks. |
| 22 | NWDS = 9 | |
| 38 | | The 16 words of system performance monitors |
| 39 | IBLK = 633 | Identify the time that reports were transmitted from the system. |
| 40 | Sector # NWDS = 2 | |
| 41 | XMIT Time Hi | Two words of time (milliseconds) |
| 42 | XMIT Time Lo | |
| 43 | IBLK = 631 | Identify the surveillance target report block for this sector. |
| 44 | NRPTS NWDS = ? | |
| | | 10 word block segments for each surveillance report |
| X = 44 + NRPTS * 10 | | Identify the surveillance track file recording block for this sector. |
| X + 1 | IBLK = 999 | |
| X + 2 | NTRKS NWDS = ? | 16 word block segments for each surveillance track file entry |
| Y = (X+2) + NTRKS*16 | | |

Fig. 7-1. AMPS Tape Record.

| | | ← 32 bits → | |
|------|--|--|--|
| Word | | | |
| 1 | AMPS Performance Block #1. Recorded with Sector 1 from North | # Words = 9 | |
| 2 | P.M. Word #1. P1 Pulse Power in Watts (LSB = 10W) | P.M. Word #2. P2 Pulse Power in Watts (LSB = 10W) | |
| 3 | P.M. Word #3. dB Σ (LSB = 1dB). The quantized sum video signal from directional antenna | P.M. Word #4. dB Ω (LSB = 1dB). The received omni signal from the omni directional antenna. | |
| 4 | P.M. Word #5. Δ/Σ for $\Delta=+\Sigma$ in degrees (LSB = .1°). | P.M. Word #6. Δ/Σ for $\Delta=-\Sigma$ in degrees (LSB = .1°). | |
| 5 | P.M. Word #7. Δ/Σ for $\Delta = 0$ in degrees (LSB = .1°). | P.M. Word #8. Σ noise in MV (LSB = 10 MV). | |
| 6 | P.M. Word #9. Ω noise in MV (LSB = 10 MV). | P.M. Word #10. First error word. | |
| 7 | P.M. Word #11. Second error word. | Sensor Range. In counts, LSB = 1/256 nmi. | |
| 8 | Pulse Repetition Frequency (PRF). | System Run Status. Standby \neq 0; Run = 0 (countdown) | |
| 9 | Scan Interval (16 bits in milliseconds). | Hardware Operational Mode. Internal = 0; External \neq 0 | |

Fig. 7-2. AMPS Hardware Performance Monitor Data.

32 bits

| | | | | |
|-----------|---|---------------------|---------------------|---------------------|
| Word 1 | AMPS Performance Block #2 Recorded with Sector 2 from North. | | # Words = 9 | |
| 2 | Active Range (AR) for Sector 1(nmi) | AR for Sector 2 | AR for Sector 3 | AR for Sector 4 |
| 3 | AR for Sector 5 | AR for Sector 6 | AR for Sector 7 | AR for Sector 8 |
| 4 | AR for Sector 9 | AR for Sector 10 | AR for Sector 11 | AR for Sector 12 |
| 5 | AR for Sector 13 | AR for Sector 14 | AR for Sector 15 | AR for Sector 16 |
| 6 | AR for Sector 17 | AR for Sector 18 | AR for Sector 19 | AR for Sector 20 |
| 7 | AR for Sector 21 | AR for Sector 22 | AR for Sector 23 | AR for Sector 24 |
| 8 | AR for Sector 25 | AR for Sector 26 | AR for Sector 27 | AR for Sector 28 |
| 9 | AR for Sector 29 | AR for Sector 30 | AR for Sector 31 | AR for Sector 32 |

Fig. 7-3. Active Sensor Range.

| ← 32 bits → | | |
|-------------|---|---|
| Word 1 | AMPS Performance Block #3 Recorded with Sector 3 from North. | # Words = 9 |
| 2 | The total number of hardware generated replies last scan. | The number of replies attempted to be processed by software last scan. |
| 3 | The number of replies that fit into the software reply buffer last scan. | The number of replies processed to form target reports last scan. |
| 4 | The total number of target reports formed last scan. | The number of target reports sent to the correlation/tracker last scan. |
| 5 | The total number of interrogation sweeps last scan. | The number of sweeps which had sufficient time to be processed fully last scan. |
| 6 | The number of sweeps which did not have time to be processed at all last scan. | The number of sectors sent to the correlation/tracking functions without any delay last scan. |
| 7 | The number of sectors sent to the correlation/tracking functions slightly late last scan. | The number of sectors sent to the correlation/tracking functions very late last scan. |
| 8 | The number of sectors dropped from the correlation/tracking functions last scan. | The total number of tracks in the system last scan. |
| 9 | The total number of correlated and updated tracks last scan. | The total number of uncorrelated and coasted tracks last scan. |

Fig. 7-4. AMPS Software Surveillance Processing Characteristics.

← 32 bits →

| | | | | |
|-----------|---|---------------------------------------|---|--|
| Word 1 | AMPS Performance Block #4. Recorded with Sector 4 from North. | | # Words = 9 | |
| 2 | CPME Range in counts (LSB = 1/256 nmi). | | CPME azimuth in counts (LSB = $360/2^{16}$ degree). | |
| 3 | Range difference between measured CPME and surveyed CPME in counts. | | Azimuth difference between measured CPME and surveyed CPME in counts. | |
| 4 | CPME Mode A code. | | CPME Mode A code confidence. | |
| 5 | CPME Mode C code (altitude). | | CPME Mode C code confidence. | |
| 6 | CPME special bits. | | Number of replies for CPME target (6 bits) | CPME track number (10 bits) |
| 7 | CPME Mode 2 code. | | CPME Mode 2 code confidence. | |
| 8 | Range of pseudo target generated by hardware in counts (LSB = 1/256 nmi). | | Azimuth of pseudo target generated by hardware in counts (LSB = $360/2^{16}$ degree). | |
| 9 | Number of replies for pseudo target (6 bits). | Pseudo target track number (10 bits). | Number of hardware pseudo targets last scan (8 bits). | Number of CPME targets last scan (8 bits). |

Fig. 7-5. Calibration Performance Monitoring Equipment.

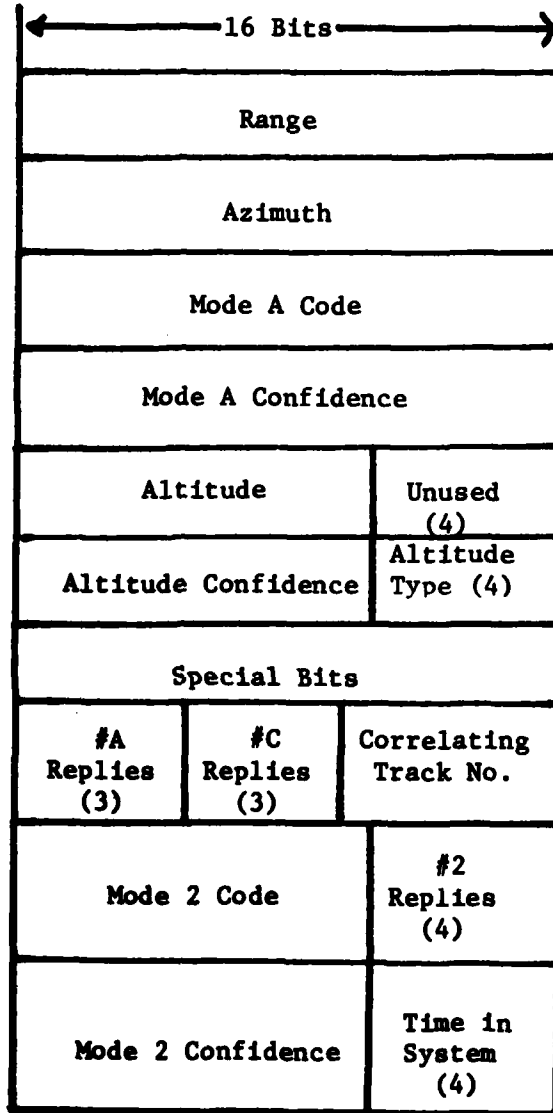

Fig. 7-6. (1 of 2)
IBLK 631 Target Report

Note:

Range LSB is 1/256 nmi
Azimuth LSB is $360^\circ/2^{16}$ degrees
Mode A code is $A_4A_3A_2A_1B_4B_3B_2B_1C_4C_3C_2C_1D_4D_3D_2D_1F_1F_2X$ SPI
Mode A confidence is same order as code, "0" = high confidence
Altitude is in either flight level or bits depending on altitude type
Altitude confidence is "0" = high confidence
Altitude type is 4 bits of information

where: 0 flight level
1 garbled level
2 no replies of this mode
3 garbled brackets
4 clear brackets

The following are the special bits:

Test targets
Edited out target
False target
Boresight target
Radar reinforced
Code in transition
Potential swap target
Swap performed
Reconstructed target
Discretely correlated
Velocity reasonableness used
2-on-2 or many-on-1 case
Many-on-many case
Deviation score used
Turn detected
Code improved

Some special bits are used to filter out the display of some types of reports, or to flag certain displayed reports. Others are used during the post real-time analysis processing. Refer to Section 7.2 for a description of special bits.

#A replies is the number with this target of that mode.
#C replies is the number with this target of that mode.
Correlating track number is the AMPS track with this target.
Mode 2 Code, confidence and replies are self explanatory.
Time-in-system is quantized to LSB = 1/8 sec.

Fig. 7-6. (2 of 2) IBLK 631 Target Report, Notes

3. Split targets: A split target occurs when the reply sequence from an aircraft is separated by reply correlation into two or more target reports due to certain system defects such as an out-of-spec transponder.
4. Ringaround targets: These targets are defined as those targets formed by high elevation angle, short range, sidelobe replies which are not flagged as sidelobe because of the failure of the antenna patterns in that region.

c. False Target

These are targets caused by the reflection of aircraft replies from buildings, hangers, or other structures near the sensor. They appear to be aircraft positioned behind the reflector.

d. Boresight Target

If sufficient monopulse estimation information is not available for a report, and a simple beam-splitting or averaging method is employed to estimate its azimuth, the target is said to be a boresight target.

e. Radar Reinforced: Not currently used.

f. Code-in-Transition

This bit is set whenever a target report code disagrees with the code of the correlating track.

g. Potential Swap Target

Whenever two target reports are sufficiently near one another that code swapping might be required to correct reply correlation errors, this bit is set for both reports.

h. Swap Performed

If the processor actually performed the code swap routine on this target, this bit is set.

i. Reconstructed Target

Replies from an out-of-spec transponder may result in the creation of two target reports for one aircraft, each report representing only one mode. The processor identifies these cases and creates a single target report.

j. Discretely Correlated

Refer to Section 4.3 for correlation method.

k. Velocity Reasonableness Test Used

This bit is set for a target report which entered a test with a potentially correlating track to judge the reasonableness of the required aircraft velocity change.

1. 2-on-2 or Many-on-1 Case

This bit is set for reports which were part of one of the following association cases:

- i 2 tracks with 2 targets.
- ii Many tracks with 1 target.
- iii Many targets with 1 track.

m. Many-on-Many Case

This bit is set for reports which are part of association situations with at least two reports and two tracks. Together with the previous bit, this allows all possible association conditions to be identified.

n. Deviation Score Used

Each target/track association is given a score, which is a measure of the certainty of the association. Should a complex association create scores that are ties among the target/track pairs, a deviation score algorithm is used to break the ambiguity. The algorithm uses the geometric differences between the track/target pair and indicates the likelihood of the aircraft under track being at the position presented by the target report.

o. Turn Detected

This bit is set when the turn detection algorithm confirms a turning track.

p. Code Improved

This bit is set when the report's code and confidence values are improved by making use of the track code and confidence.

7.3 Track Report Blocks

The format of a track file block is presented in Fig. 7-7. Many of the fields are identical to those of target reports. However, the ones that are unique, and the special bits (which have different meanings), require a detailed understanding of surveillance processing. The reader is referred to Chapters 8 and 9 of Ref. 3 for a detailed discussion.

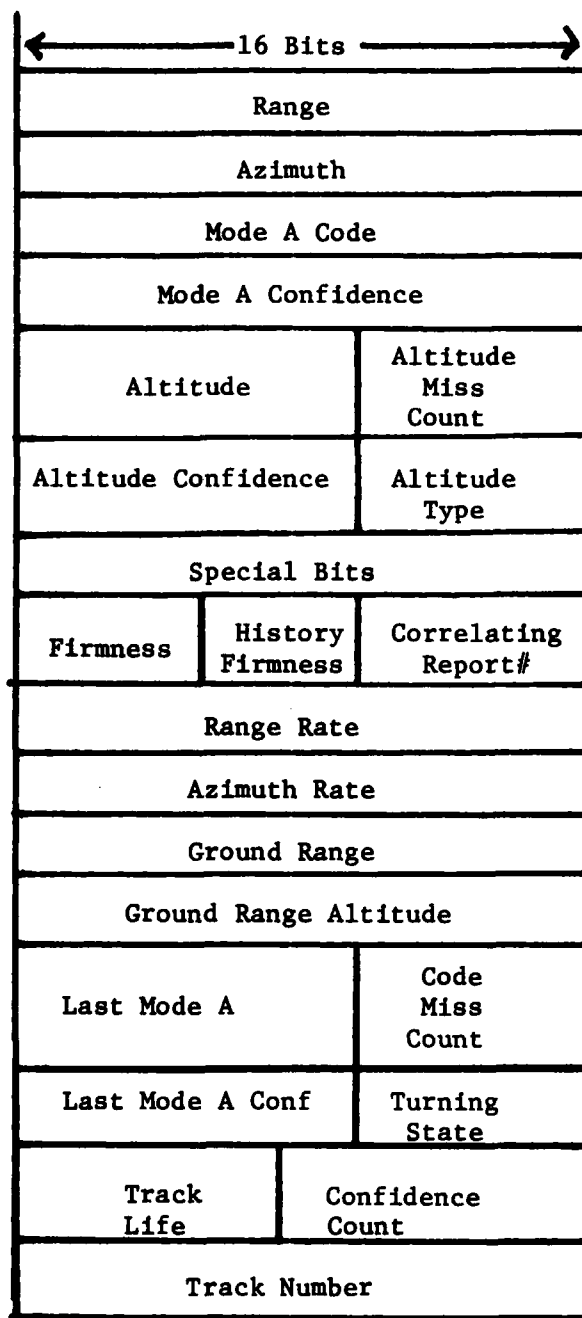

Fig. 7-7. AMPS Surveillance Track.

8. AMPS DATA DISPLAY AND OUTPUT

The AMPS processor has the capability of recording data, as well as supporting the real-time display of surveillance target reports. Three different external facilities may be interfaced to AMPS, no more than two at a time. These facilities are: (1) Megatek Display, (2) NAS, and (3) ARTS.

a. Megatek Display

This display, an integral part of the AMPS system, is its primary visual medium. The design and capabilities of the MEGATEK display are discussed later in this report.

b. NAS

AMPS has the capability of interfacing directly with a NAS enroute flight facility.

c. ARTS

AMPS also has the capability of interfacing directly with an ARTS terminal flight facility.

The interfacing for each entity is accomplished through a dedicated microprogrammable interface which resides between the 11/55 processor and the outlying facilities. Each interface board is programmed to output the surveillance data in the proper format for the desired facility. Details of the microprocessor are found in Chapter 9.

8.1 Output Buffer

The surveillance processor in the 11/55 sets up a buffer (IOBUFF) of target reports in the format described in Fig. 8-1. When surveillance processing is completed for a sector, a QIO output is initiated for each desired device channel with the surveillance data for that sector. The 11/55 has three separate output channels (DR11-B's), one for each of the three microprocessors.

The maximum number of reports per sector is 50. This worst-case figure, plus a sector header block, indicates that the maximum transmission size is 510 words. If an allowance is made for 4 sectors of data in the IOBUFF at one time, the total storage required is 2040 16 bit words.

8.2 Buffer Structure

The microprocessors handling the I/O between the 11/55 and the external facilities perform the reformatting required by each facility. Although these microprocessors unburden the 11/55 from having to reformat the data, the relatively slow data transmission rates require that the data be buffered. A mechanism was developed which allows for a maximum of 10 pending QIOs (in the process of completing) to exist at the same time to make up for the slower microprocessor I/O channels. The 11/55 executive services handle the details of this multi-buffering.

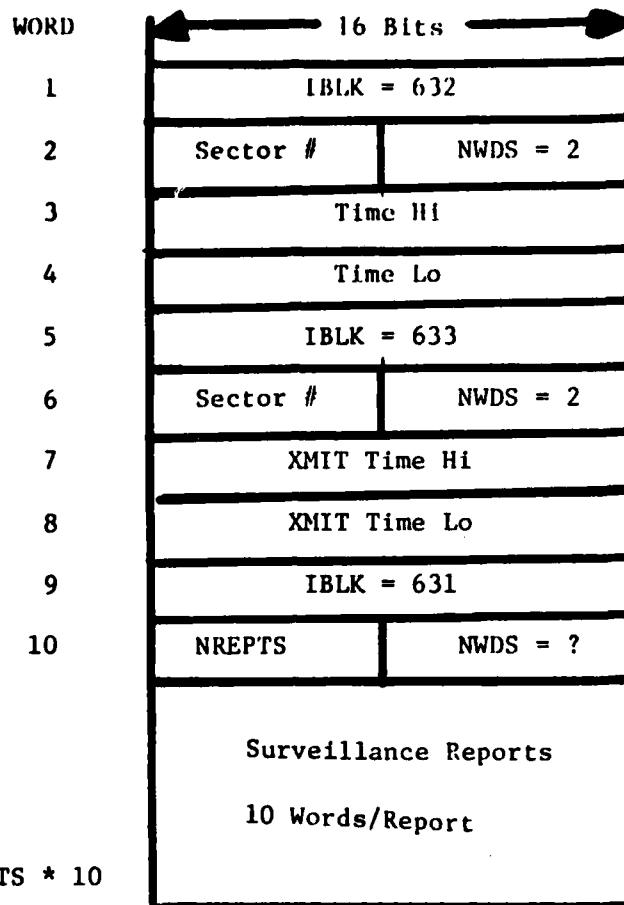

$$X = 10 + NREPTS * 10$$

Fig. 8-1. Surveillance Output Buffer.

Note: The definitions of the target report data fields are as shown in Fig. 7-6.

Note that the ten words preceeding the first report are the minimal number of words which go out each sector. They define the start of a new sector (Sector Header Message).

The IOBUFF format is shown in Fig. 8-2a. The QIO numbers (1-10) for each sector output, in particular for each 10 word block, are stored in an array called IONUM. The QIO number for each 10 word block may then be directly retrieved whenever necessary. See Fig. 8-2b.

Each 10 word block in IOBUFF has the starting address for that block stored in an I/O address array called IOADD. IOADD is initialized using the operating system Get Address Directive. Since a QIO for a sector may be issued from anywhere within the IOBUFF, the correct starting address must be given as part of the QIO directive. This array facilitates the address retrieval. See Fig. 8-2c.

The I/O status array is shown in Fig. 8-2d. This array maintains the status of each of the 10 possible QIO requests for each of the 3 possible output devices. Whenever a QIO is issued, the array elements for that request that correspond to the devices selected are set to indicate pending status. As each transfer is completed, a QIO completion condition is returned, and the corresponding array element can be set to clear status. When all 3 array elements for a QIO are clear, the QIO is known to be finished. The QIO storage blocks (known via the IONUM array) are then free to be used by subsequent sectors.

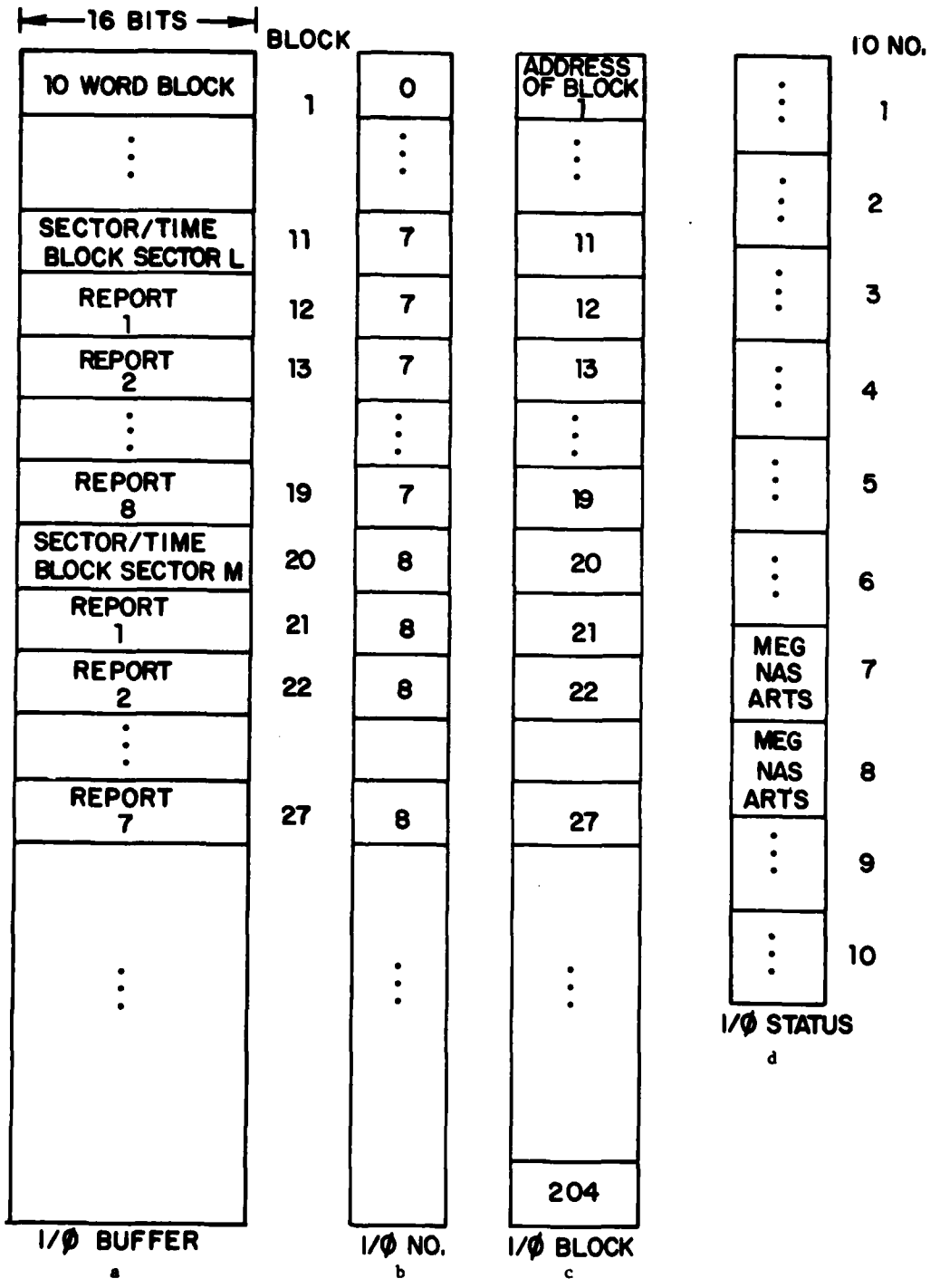

Fig. 8-2. I/O Data Structures.

9. AMPS MICROPROCESSOR INTERFACE

The AMPS surveillance computer is connected to external devices through microprocessor-controlled interfaces as depicted in Fig. 9-1. Each interface is a single board located in a DR11-B direct-memory channel. The present configuration of AMPS has three of these channels. The first interface is to a Megatek intelligent graphics display, the second communicates with NAS sites through two data lines, and the third communicates with ARTS sites through a single data line (see Fig. 9-2). Each interface performs all necessary data reformatting, thus relieving the load on the main computer. Since the interface has a small computer in it, different data formats may be achieved by reprogramming the interface.

The interface hardware consists of a Motorola 6802 microprocessor, 128 bytes of RAM, 1 K bytes of ROM, two synchronous serial output ports, a parity generator, and auxiliary logic for communication with the DR11-B channel. The ADCCP (ARTS) interface replaces the synchronous channels with a single ADLC communication port. Otherwise, the only differences among the interfaces is the software contained in the respective ROMs. Figure 9-3 flow charts the microprocessor software.

Functionally, each interface program is identical. A main program is set up which loops upon itself, seeking to acquire target reports from the computer by interrogating the DR11-B channel. Each report is composed of 10 16-bit words which are transferred through the channel. Once the report has been transferred to the interface memory the necessary reformatting is done. The main program seeks to keep its buffers full of processed target reports. Meanwhile, the output channels are transferring the report data to the outside world. Whenever a channel needs data, it issues an interrupt to the microprocessor. The processor responds to the interrupt by either sending the next data byte from the target-report buffer, or, if there is no target report presently available, by placing the channel in an idle mode until a report is available. Figure 9-4 describes the microprocessor interrupt routine.

The address space of the interface computer is arranged so that RAM occupies the first 256 bytes and ROM the last 1 K bytes (RAM addresses 0000 to 00FF and ROM addresses FC00 to FFFF, all addresses in hex). The 16 bits of data from the DR11-B come into ports at addresses A000 and B000. The data ports are addressed at 4000 and 5000. (The ADLC on the ADCCP interface is at 4000). The status of the DR11-B is read by a port at 8000. A request for data to the DR11-B is made by addressing 3000. For further hardware description, see the schematic diagrams.

9.1 Megatek Interface Software

The Megatek driver program is the simplest interface program, as no reformatting is necessary. The interface simply transfers data blocks intact. Figs. 8-1 and 7-6 describe the format of these data blocks. The program employs double 24-byte data buffers, with one being filled in parallel with the transmission of the other. There is a preamble containing one fill character, hex FF, and three synchronization characters, hex EA. This preamble is followed by the 20 bytes of a target report. Note that the

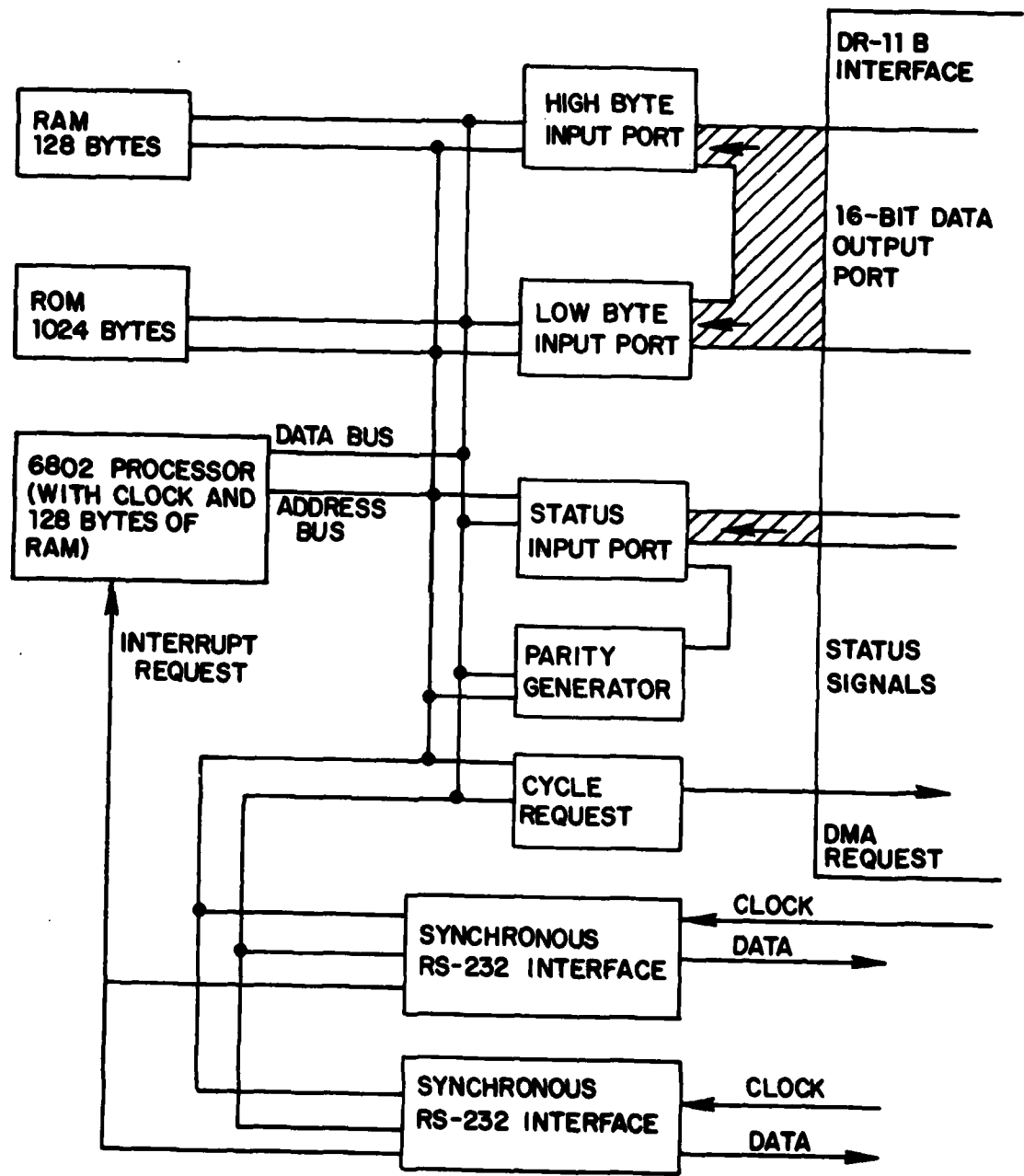

Fig. 9-1. Microprocessor Interface.

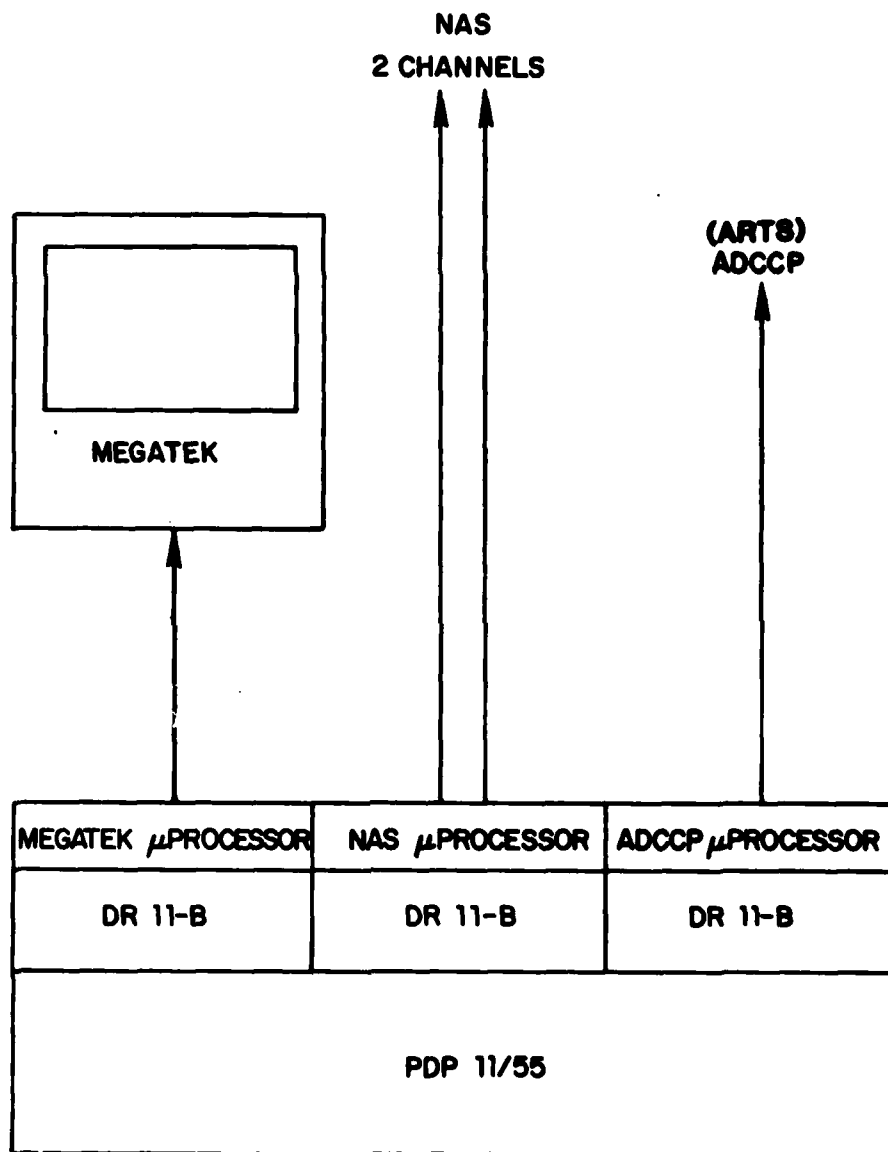

Fig. 9-2. Interface Data Lines.

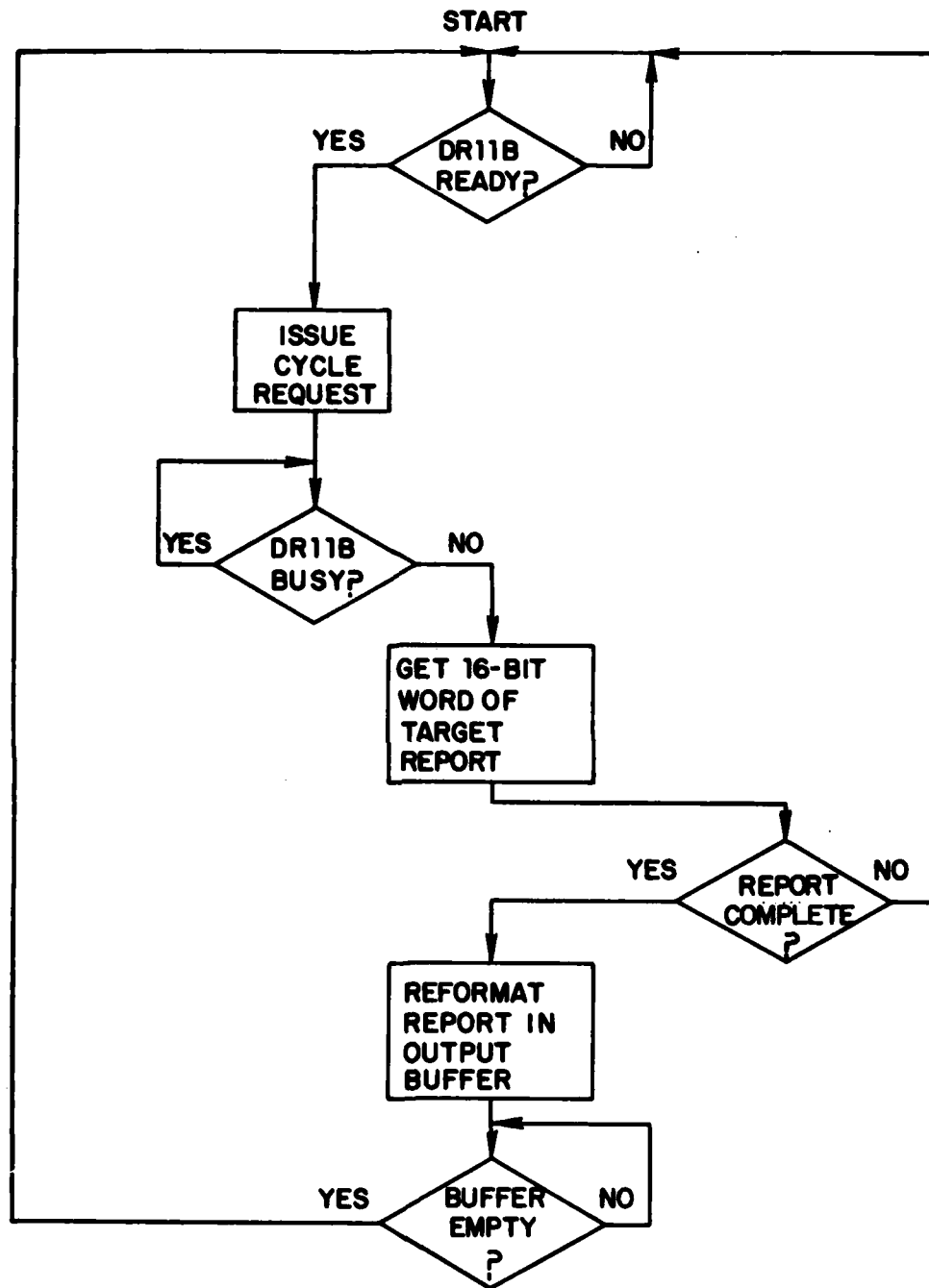

Fig. 9-3. Flow Chart of the Microprocessor.

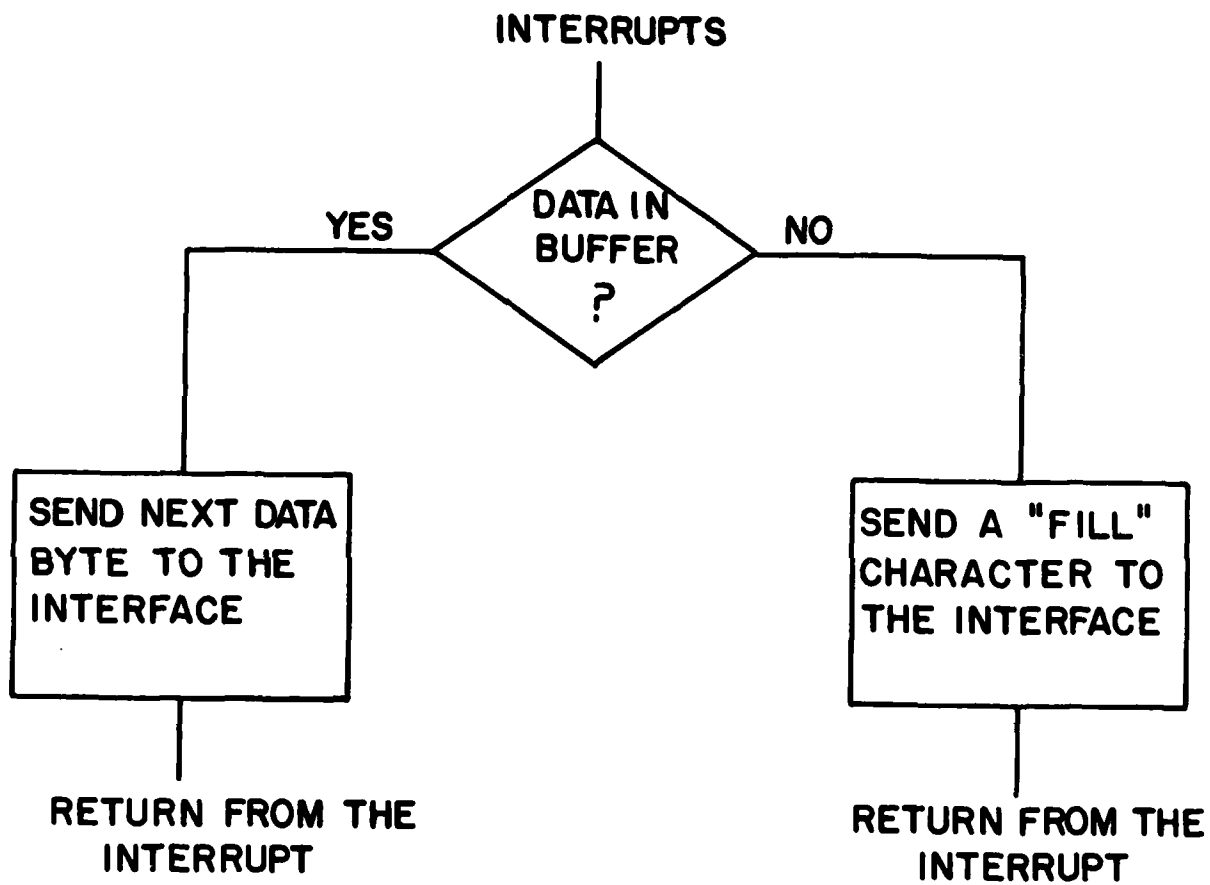

Fig. 9-4. Microprocessor Interrupt Routine.

synchronous channels transmit the least-significant (rightmost) bit first. Note also that the Megatek driver used only one of the synchronous ports as shown in Fig. 9-2. The transmission on the data line consists of 8-bit characters with odd parity appended. The data rate is 9600 bps, as determined by the clock signal from the Megatek.

9.2 NAS Interface Software

The NAS driver program is complicated by the need to drive two simultaneous data channels. Also, the data format required by NAS is very different from that of AMPS as NAS uses 12-bit words with odd parity. The NAS target report consists of seven 13-bit fields as shown in Fig. 9-5 with an appended synchronous field, also 13 bits. Since the microprocessor is an 8-bit machine, the data fields must be packed end-to-end in a 13 byte buffer by shifting them in one bit at a time. Care must be taken to reverse the bit ordering of data, since the channels require the least-significant bit first. The NAS program is organized with four independent data buffers. At any moment, two buffers will be in the process of output while a third is being filled. Program timing is such that two buffers can be reformatted and filled in the time required to transmit one buffer. Thus, the main program loop is nearly always left waiting for an empty buffer to fill. The subroutine that gets data from the DR11-B is the same one used by the Megatek software. The synchronous channels are incapable of deriving the parity of a 12-bit word, so an external parity generator is used. The parity generator returns the parity of an 8-bit value. A software subroutine uses this hardware to develop the parity of a 12-bit entity.

A NAS target report consists of seven data fields. A synchronization field is appended to each report in a buffer, and sync fields are transmitted between reports. If no full buffer is available, a buffer full of syncs is sent. Both channels are run at 2400 baud. The channels transmit full buffers on a first-come-first-serve basis.

The data block coming through the DR11-B channel from the AMPS computer contains sector-header messages. These 10 word data blocks give data on the sector boundary. NAS cannot use these messages, so the NAS interface detects these messages and ignores them. It will transmit only reformatted target reports.

9.3 ADCCP (ARTS) Interface Software

This interface must reformat data for the ADLC communication protocol required by ARTS sites. Most of this protocol is handled by the ADLC circuitry on the interface card. Both target reports and sector messages are reformatted. The ADLC drives a single data line at 9600 baud.

The ADCCP program is much like the Megatek driver. It also uses double buffers, and the subroutine to access data through the DR11-B is identical. The last transfer of any buffer must be handled specially for the ADLC. A special data port receives only the last data byte of each buffer, thus

| ØBG | | MSG BIT NO. | BEACON | | |
|------------|------------|-------------------|---------------|------|-------|
| FLD CNT | BIT CNT | | | | |
| 1 | 12 | 1 | RTQC/TEST | | |
| | 11 | 2 | 1 | | |
| | 10 | 3 | 1 | | |
| | 9 | 4 | MODE 2 | | |
| | 8 | 5 | MODE 3/A | | |
| | 7 | 6 | MODE C | | |
| | 6 | 7 | IDENT | | |
| | 5 | 8 | RADAR REINF. | | |
| | 4 | 9 | 7700 | | |
| | 3 | 10 | 7600 | | |
| | 2 | 11 | FRA | | |
| | 1 | 12 | AF | | |
| | 0 | 13 | PARITY | | |
| 2 | 12 | 14 | MSB | 128 | NM |
| | 11 | 15 | | 64 | _____ |
| | 10 | 16 | | 32 | _____ |
| | 9 | 17 | RANGE (11) | 16 | _____ |
| | 8 | 18 | | 8 | _____ |
| | 7 | 19 | | 4 | _____ |
| | 6 | 20 | | 2 | _____ |
| | 5 | 21 | | 1 | _____ |
| | 4 | 22 | | .5 | _____ |
| | 3 | 23 | | .25 | _____ |
| | 2 | 24 | LSB | .125 | NM |
| | 1 | 25 | SPEC. TGT. | | |
| | 0 | 26 | PARITY | | |

| ØBG | | MSG BIT NO. | BEACON | | |
|------------|------------|-------------------|-----------------|------|-------|
| FLD CNT | BIT CNT | | | | |
| 3 | 12 | 27 | MSB | 2048 | ACP |
| | 11 | 28 | | 1024 | _____ |
| | 10 | 29 | | 512 | _____ |
| | 9 | 30 | AZIMUTH (12) | 256 | _____ |
| | 8 | 31 | | 128 | _____ |
| | 7 | 32 | | 64 | _____ |
| | 6 | 33 | | 32 | _____ |
| | 5 | 34 | | 16 | _____ |
| | 4 | 35 | | 8 | _____ |
| | 3 | 36 | | 4 | _____ |
| | 2 | 37 | | 2 | _____ |
| | 1 | 38 | LSB | 1 | ACP |
| | 0 | 39 | PARITY | | |
| 4 | 12 | 40 | AIMS PRESENT | | |
| | 11 | 41 | MSB AIMS | | |
| | 10 | 42 | LSB AIMS | | |
| | 9 | 43 | DISCRETE | | |
| | 8 | 44 | MODE 2 "X" | | |
| | 7 | 45 | MODE 3/A "X" | | |
| | 6 | 46 | MSB | 4 | SEC |
| | 5 | 47 | | 2 | _____ |
| | 4 | 48 | TIME IN | 1 | _____ |
| | 3 | 49 | STORAGE (6) | 1/2 | _____ |
| | 2 | 50 | | 1/4 | _____ |
| | 1 | 51 | LSB | 1/8 | SEC |
| | 0 | 52 | PARITY | | |

Fig. 9-5. NAS Report Format.

| ØBG | | MSG | | |
|---------|---------|---------|-----------|----|
| FLD CNT | BIT CNT | BIT NO. | BEACON | |
| 5 | 12 | 53 | | A4 |
| | 11 | 54 | | A2 |
| | 10 | 55 | | A1 |
| | 9 | 56 | | B4 |
| | 8 | 57 | MODE 3/A | B2 |
| | 7 | 58 | CODE (12) | B1 |
| | 6 | 59 | | C4 |
| | 5 | 60 | | C2 |
| | 4 | 61 | | C1 |
| | 3 | 62 | | D4 |
| | 2 | 63 | | D2 |
| | 1 | 64 | | D1 |
| | 0 | 65 | PARITY | |
| 6 | 12 | 66 | | D4 |
| | 11 | 67 | | C1 |
| | 10 | 68 | | A1 |
| | 9 | 69 | | C2 |
| | 8 | 70 | MODE 2 | A2 |
| | 7 | 71 | CODE (12) | C4 |
| | 6 | 72 | | A4 |
| | 5 | 73 | | B1 |
| | 4 | 74 | | D1 |
| | 3 | 75 | | B2 |
| | 2 | 76 | | D2 |
| | 1 | 77 | | B4 |
| | 0 | 78 | PARITY | |

| ØBG | | MSG | | |
|---------|---------|---------|-------------------|-------|
| FLD CNT | BIT CNT | BIT NO. | BEACON | |
| 7 | 12 | 79 | SIGNx0 = +, 1 = - | |
| | 11 | 80 | 102400 | _____ |
| | 10 | 81 | 51200 | _____ |
| | 9 | 82 | 25600 | _____ |
| | 8 | 83 | 12800 | _____ |
| | 7 | 84 | MODE 6400 | _____ |
| | 6 | 85 | C Alt. 3200 | _____ |
| | 5 | 86 | (11) 1600 | _____ |
| | 4 | 87 | 800 | _____ |
| | 3 | 88 | 400 | _____ |
| | 2 | 89 | 200 | _____ |
| 1 | 90 | 100 | _____ | |
| 0 | 91 | PARITY | | |

Fig. 9-5. NAS Report Format. (Con't)

signalling the ADLC to perform CRC generation and to append a special flag to the message being transmitted. The ADLC interrupt is disabled between data block transfers, since the ADLC circuitry is capable of maintaining the data line between data transmissions. (It sends a continuous stream of "flags").

The ADCCP data format is given in Figs. 9-6 and 9-7.

| FIELD # BITS | FLAG | ID | LIVE/ PLAYBACK | UNUSED | SECTOR NUMBER | MISSION TIME |
|--------------|------|----|-------------------|--------|------------------|--------------|
| 8 | 0 | 1 | 0 | 4 | 8 | 32 |
| | | 3 | 1 | | LSB | MSB |

| TRANSMISSION TIME | CRC | FLAG |
|-------------------|-----|------|
| 32 | 16 | 8 |
| LSB | MSB | LSB |

Fig. 9-6. ADCCP Header Format.

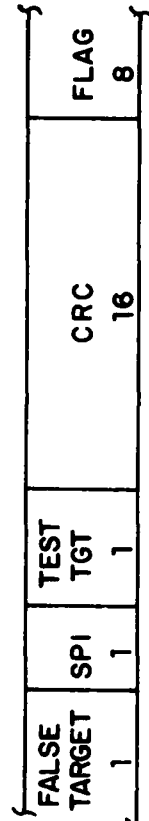
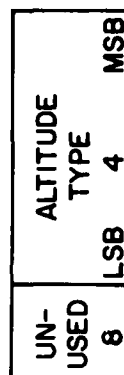
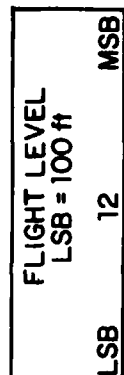
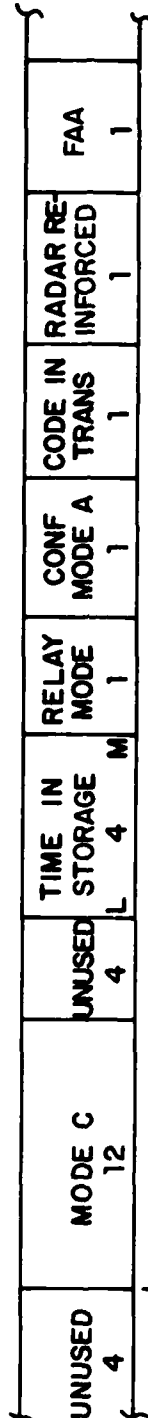
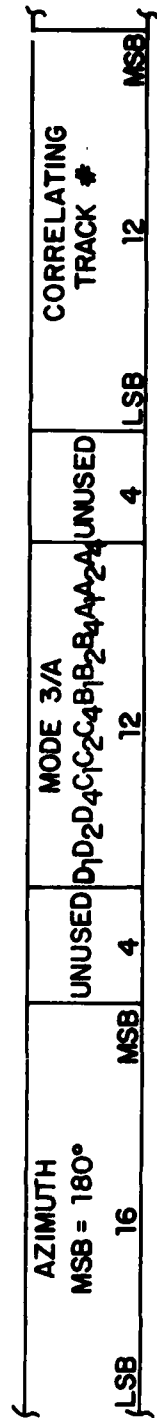
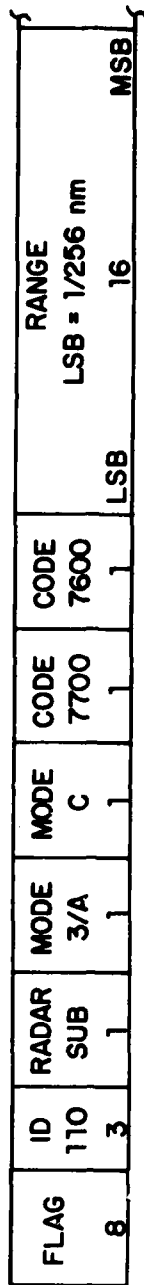

ALTITUDE TYPE CODES:

- GARBLED FLIGHT LEVEL = 1
- NO REPLIES = 2
- GARBLED BRACKETS = 3
- CLEAR BRACKETS = 4

Fig. 9-7. ADCCP Report Format.

10. AMPS HARDWARE OPERATIONS

The AMPS processor hardware consists of three racks of equipment: a single Lincoln Laboratory-built rack, which is the AMPS hardware reply processor, a Digital Equipment Corp. 11/55 central processing unit, and a DEC TU10 magnetic tape controller and drive. Operating procedures for enabling the AMPS system are described in this chapter.

10.1 AMPS Hardware Reply Processor

There are three sets of switches in this rack: (1) Power Supply Switches, (2) AMPS system control switches, and (3) azimuth sector select and reset switches. The power supply and AMPS system control switches are on the outside bottom and top halves of the rack. The azimuth sector select and reset switches are inside the top half. Refer to Figs. 10-1, 10-2, and 10-3 for sketches of the panels of this rack.

10.1.1 Power Supply Switches

To turn power on the reply processor rack, the following switches must be set:

1. The 3 switches on the monopulse processor portion of the rack.
2. The single power switch on the monopulse digitizer portion of the rack (push it on).
3. The 12V, 15V, and 5V logic supply switches.

10.1.2 AMPS System Control Switches

These switches are the following:

1. Range: sets up the range gating parameter for the hardware.
2. Trigger Source: sets up the mode of operation for AMPS.
 - i. Standby - system is idle. No replies come through for processing.
 - ii. Internal - when AMPS runs off its own transmitter, an internal PRF is set by this switch.
 - iii. External - when AMPS is slaved to another transmitter with a high PRF, the + N setting produces the proper PRF for the AMPS hardware.

10.1.3 Display Select Switch

The position of this switch controls which performance monitor (PM) values are to be displayed in the LEDs.

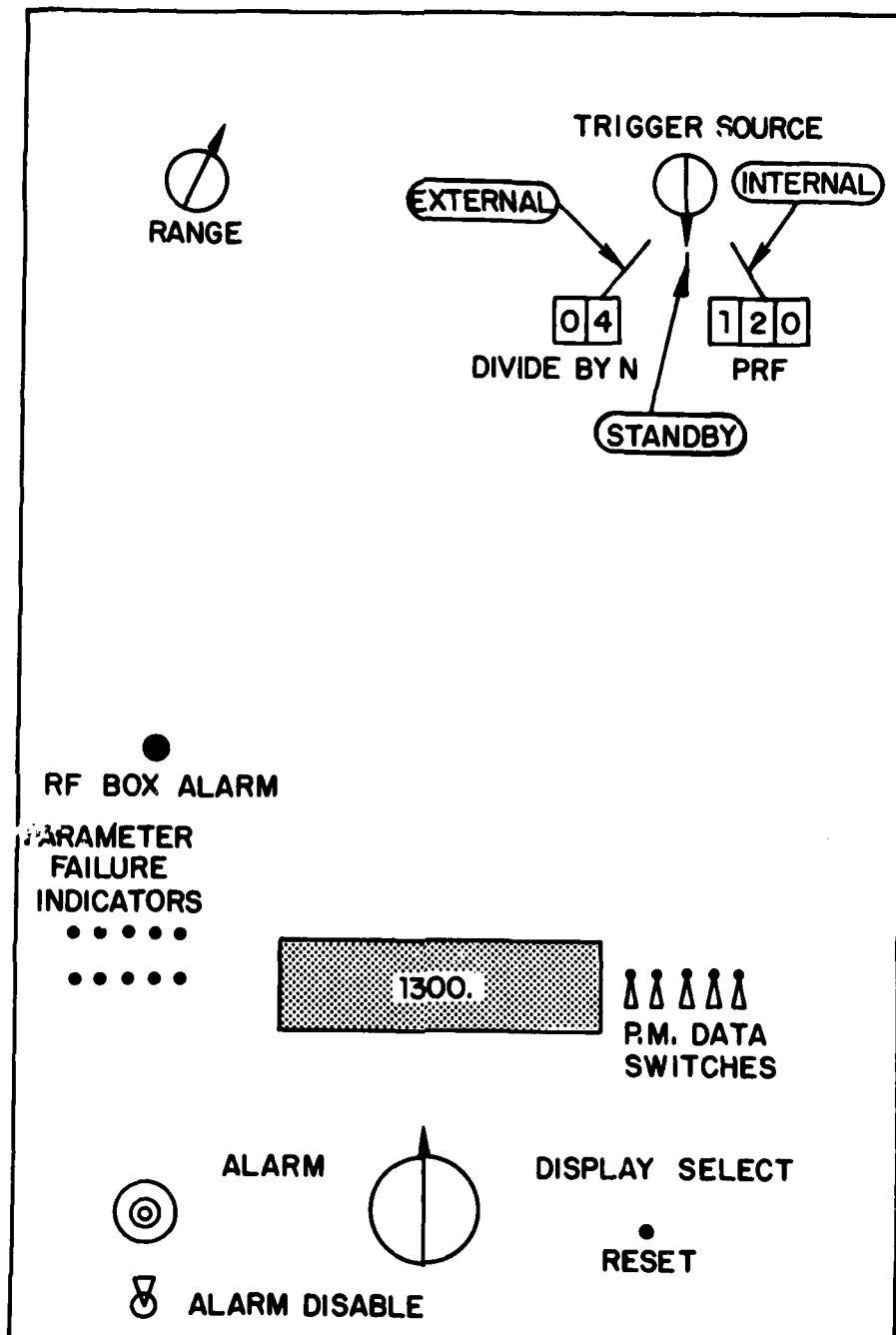

Fig. 10-1. AMPS Rack Front Panel.

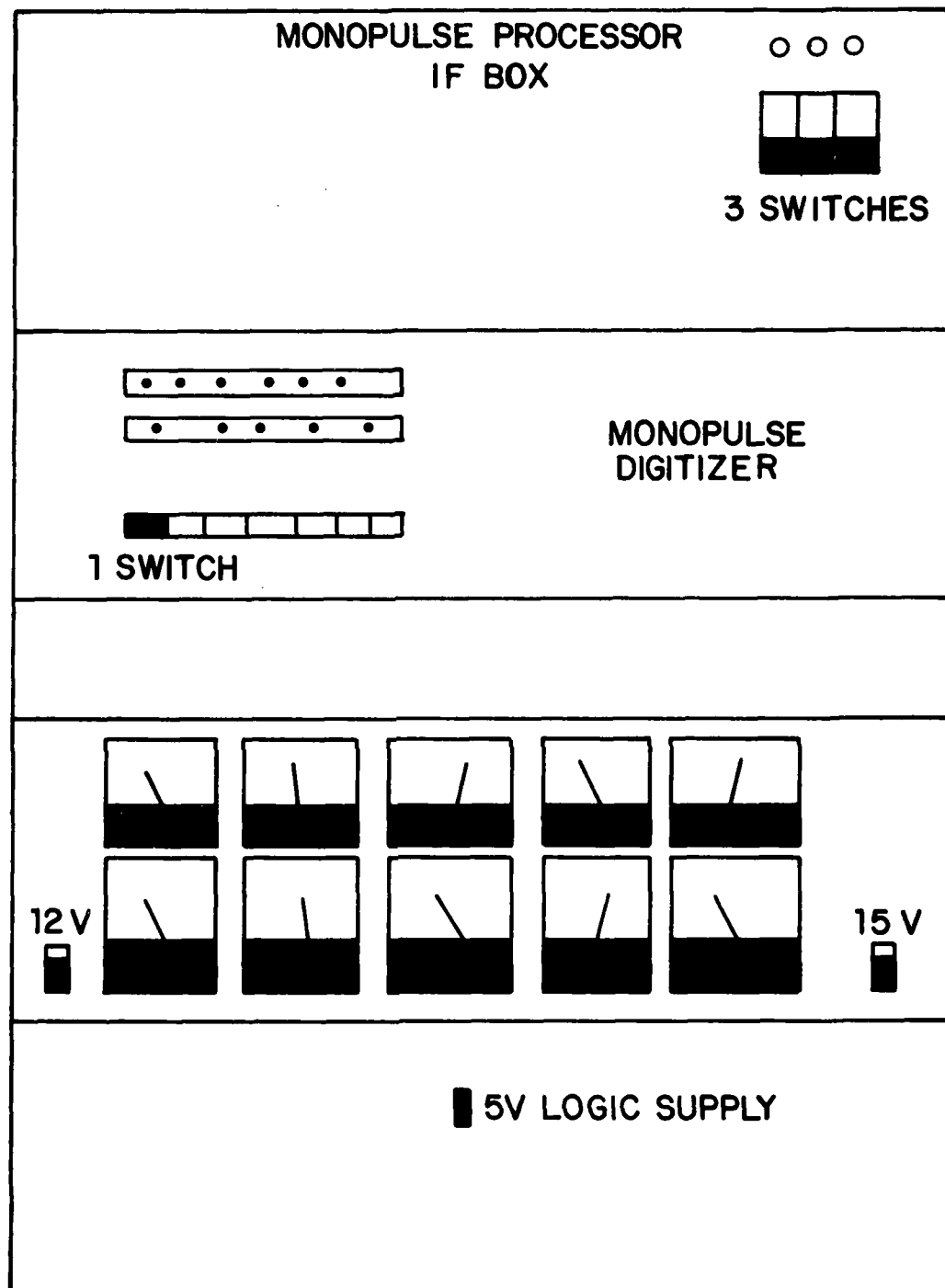

Fig. 10-2. AMPS Rack Power Supply.

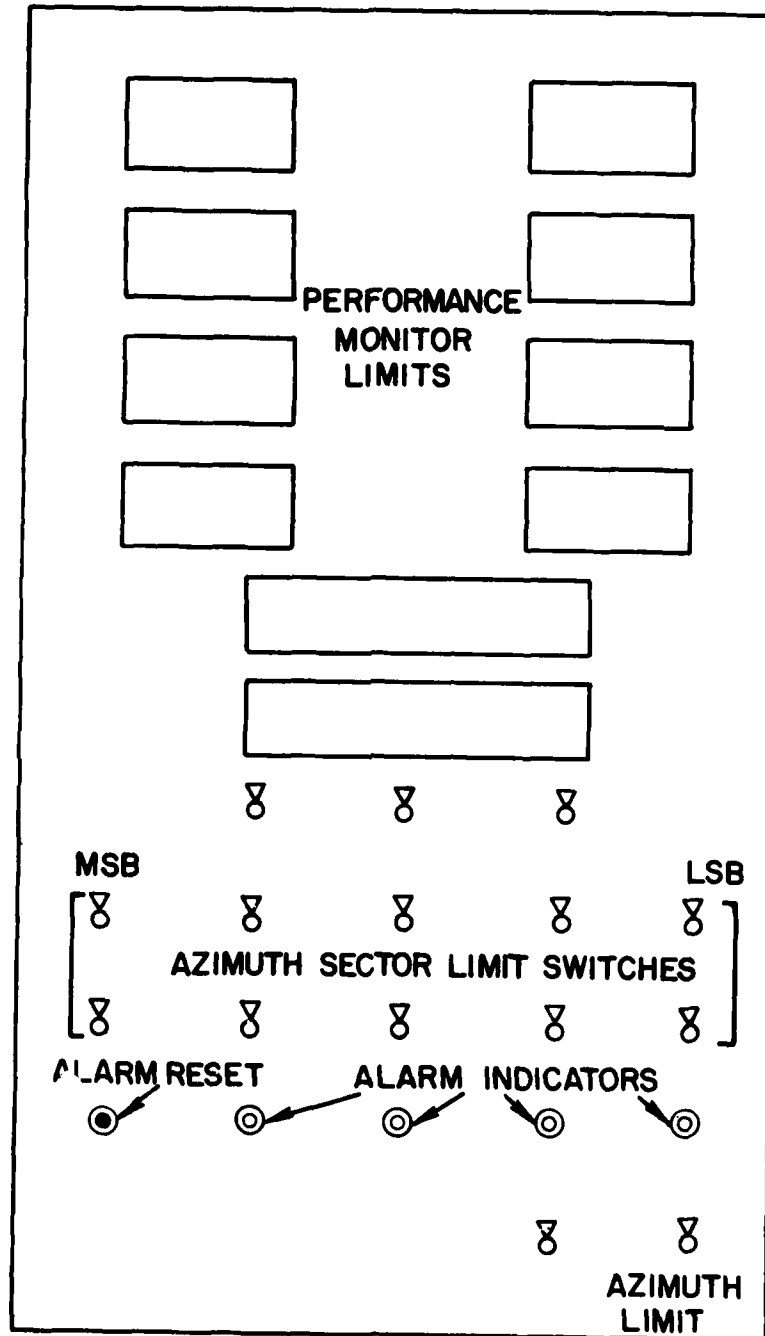

Fig. 10-3. AMPS Rack Azimuth Select Panel.

10.1.4 PM Data Switches

These switches select the PM parameters to be recorded.

10.1.5 Azimuth Sector Select and Reset Switches

These switches are found inside the upper half of the AMPS hardware rack.

The AMPS reply processing hardware has the ability to select an azimuth wedge in which replies may be processed. This wedge is enabled and disabled by the AZIMUTH LIMIT switch. The Azimuth Sector Limit switches select the starting and ending sectors of the wedge.

The principal use of the azimuth sector select switches is to define an azimuth window around the AMPS calibration source. The sector limit switches may be selected in a range from sector 0 to sector 31 by the AZIMUTH BEGIN and END switches. Each switch position is a binary representation of an azimuth sector.

When a calibration is to be performed, first the AZIMUTH LIMIT switch should be turned off. Next, the sector begin and end limits should be set sufficient to cover the azimuth sector of the calibration source. The last operation should be to turn the AZIMUTH LIMIT switch on.

10.1.6 Alarm Indicators

There is an audible alarm (Fig. 10-1) which is enabled whenever there is a system failure. The parameter failure indicators flag what part of the system failed. The alarm disable switch turns off the audible alarm and the reset button clears the failure indicator lights.

The alarm indicators beneath the azimuth sector switches (Fig. 10-3) monitor the failure of RF and IF parameters. The alarm reset button is used to turn the indicator lights off.

10.2 11/55 Operations

Although there are many separate software processors in AMPS, such as system checkout, calibration, surveillance processing, playback, and analysis, there is only one standard bootstrap procedure. The bootstrap loads the 11/55 memory with the processor requested. In a sense, the bootstrap gives the 11/55 the intelligence to run a particular set of functions.

The TU10 magnetic tape drive reads the program tape containing the process. The mounting and dismounting procedure is as follows. (Refer to Figs. 10-4, 10-5, and 10-6).

10.2.1 Off-Line/On-Line Switch

The tape mounting procedure is performed with the unit in the off-line switch position. In order to have the tape transport accept commands from

Mounting Tape

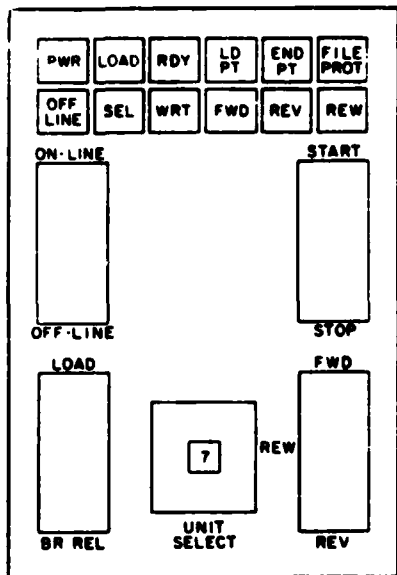

CP-0093

TU10 Control Panel.

- | Step | Procedure |
|------|--|
| 1 | Apply power to the transport by engaging the PWR ON switch at the bottom of the tape rack. |
| 2 | Ensure that the LOAD/BR REL switch is in the center position. |
| 3 | Mount the file reel onto the lower hub. |
| 4 | Place LOAD/BR REL switch to the BR REL position. |
| 5 | Unwind tape from the file reel and thread the tape over the tape guides and head assembly as shown in Figure 10-5. |
| 6 | Wind about 5 turns of tape onto the take-up reel. |
| 7 | Set the LOAD/BR REL switch to the LOAD position to draw tape into the vacuum columns. |
| 8 | Select FWD and depress START switch to advance the tape to the load point. When the BOT marker is sensed, tape motion stops, the FWD indicator goes out, and the LD PT indicator comes on. |

Fig. 10-4. Mounting Tape.

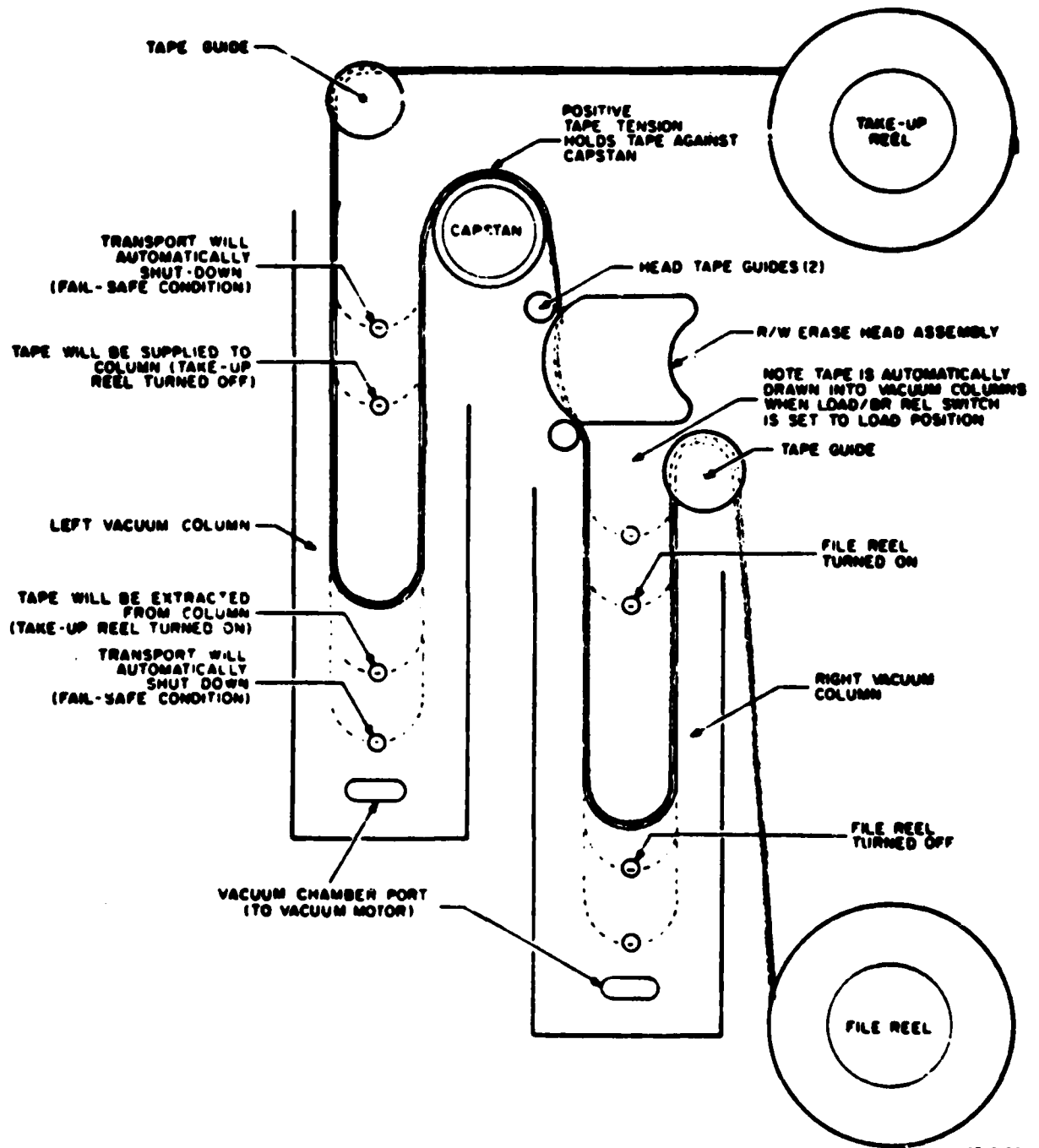

Fig. 10-5. Tape Threading.

CP 0107

Dismounting Tape

| <u>Step</u> | <u>Procedure</u> |
|-------------|---|
| 1 | Make certain the ON-LINE/OFF-LINE switch is set to the OFF-LINE position. |
| 2 | Set START/STOP switch to STOP position. |
| 3 | Set FWD/REW/REV switch to REW position. |
| 4 | Set START/STOP switch to START position. The tape should rewind until the BOT marker is reached. |
| 5 | Set LOAD/BR REL switch to BR REL position to release the brakes. |
| 6 | Gently hand wind the file reel in the counter-clockwise direction until all of the tape is wound onto the reel. |

Fig. 10-6. Dismounting Tape.

the controller when the transport is selected by the program, the switch must be placed in the on-line position.

The transport is fully on when the PWR, LOAD, RDY, LD PT, and SEL indicators are lit.

10.2.2 Read/Write Rings

This is a brief reminder of the significance of the tape read/write rings. If the tape rings are removed from the hub, the tape is considered file protected and the FILE PROT indicator will be lit. The processor will be unable to write on the tape and will not give the user any indication that it is attempting to do so. Care should be taken to insure that certain classes of tapes in AMPS are never mounted with write rings. These classes are listed here and will be defined later.

Tape which do not require write rings are:

- (1) Program Tapes
- (2) Parameter Tapes*

Tapes which will require write rings are:

- (3) Data Tapes
- (4) Parameter Tapes**

10.2.3 Front Panel Switches

Once the user has mounted the desired program tape, control is given to the 11/55 via the front panel switches. The only switches of interest are the 18 address/data switches (18-0), LOAD ADRS, HALT, START, and POWER. Fig. 10-7 shows a system operator's console of an 11/45 which is virtually the same as an 11/55.

The functions needed to get the 11/55 system going are:

| <u>Step</u> | <u>Procedure</u> |
|-------------|---|
| 1 | Power on. Key to vertical position. |
| 2 | Depress HALT. |
| 3 | Put 773000 ₈ in switches (17-0). (i.e., 17-12, 10-9 switches up). |
| 4 | Depress LOAD ADRS. |
| 5 | Raise HALT. |
| 6 | Depress START. |

*These parameter tapes are those that contain the run time parameters which were generated by the calibration process.

**These parameter tapes are those being generated by the calibration process.

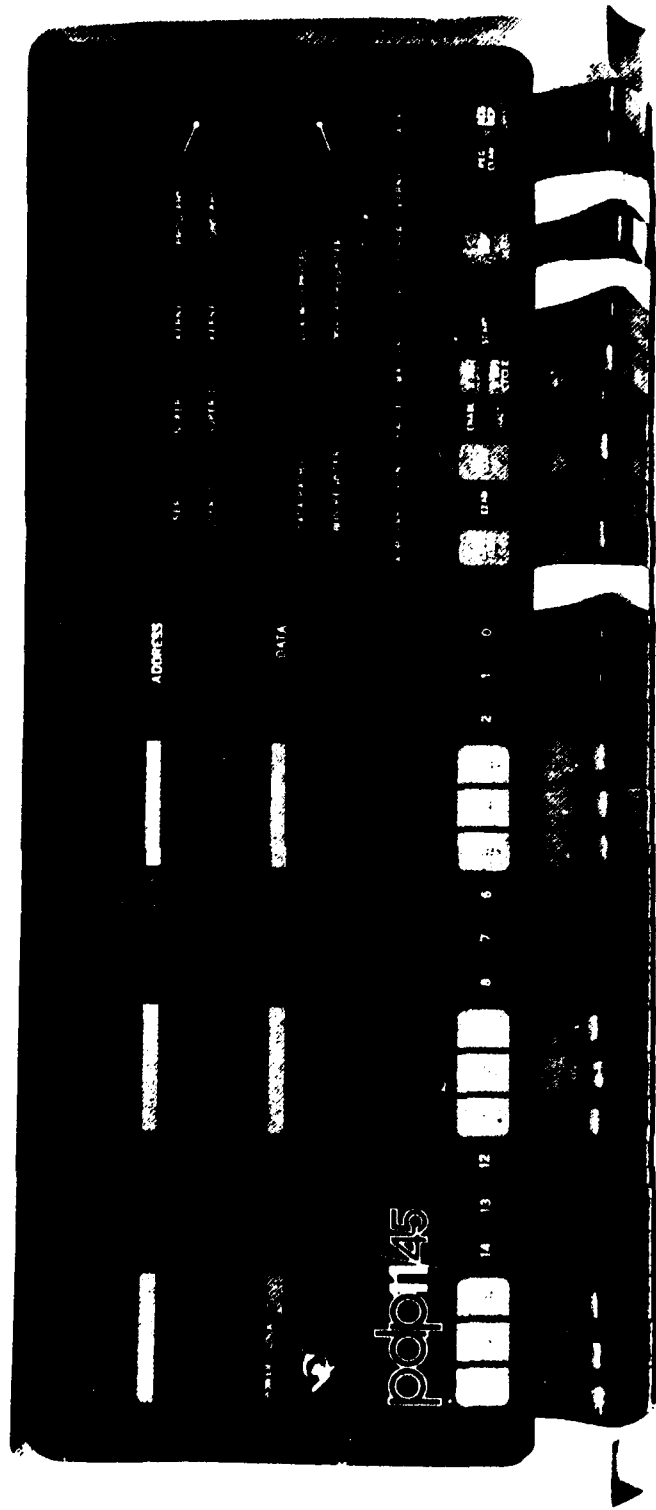

Fig. 10-7. System Operator's Console.

The 11/55 system will respond with a row of numbers and then a dollar sign on the LA36 DEC writer. Typing MT (carriage return) allows the 11/55 to read the program tape and load up the desired system. After the tape has been read, the system responds with XDT > (prompt). Type G and the response will be RSX-11S Vol, BL12 and a >. To run a task simply type RUN TASKNAME, where TASKNAME is the name of the specific task or process to be run.

10.2.4 Program Tapes

These tapes contain the various independently run systems or processes that comprise the AMPS system. The processes are: (a) System Checkout, (b) Calibration, (c) Surveillance processing, (d) Playback, and (e) Analysis. Each process is discussed in detail in Chapter 11.

A. System Checkout

System checkout is made up of four (4) separate tasks.

| | <u>Task Name</u> | <u>Function</u> |
|---|------------------|---------------------------------------|
| 1 | KTEST | Sweep Interrupt Test |
| 2 | BTEST | Reply Buffer Passage Test |
| 3 | SWEEP | Reply Level Processing |
| 4 | DRTEST | 11/55 to Outside World Interface Test |

B. Calibration (CAL55)

The calibration system serves a two-fold purpose. First, run time parameters are defined, and second, a system monopulse calibration may be performed. The end result of running the calibration is the production of a Parameter Tape, which will be used by the AMPS surveillance processor.

C. Surveillance Processing (BOB55)

This tape contains the AMPS surveillance processing system.

D. Playback (PLYBACK)

This is the system which permits the replaying of a real-time-generated tape to the outside world in either the NAS, ARTS, or Megatek format.

E. Analysis (BOBTES)

This process displays a brief but important synopsis of the real-time run.

11. LOADING, RUNNING, AND OUTPUT OF SPECIFIC PROCESSORS

The AMPS facility as described in the previous chapter consists of several separate processors or systems which run independently of one another. The following sections describe the operations necessary to load and run the various systems as well as present sample output from those processors which create output.

11.1 Calibration Process

This process characterizes the AMPS antenna, and produces a monopulse table and a parameter tape.

| <u>Step</u> | <u>Procedure</u> |
|-------------|---|
| 1 | Set Trigger Source Switch on AMPS rack to standby. |
| 2 | Set up appropriate azimuth wedge switches inside AMPS panel door (i.e., sector start/end of CPME). |
| 3 | Set PRF or + N to desired value. |
| 4 | Set range NM to 200. |
| 5 | Mount calibration system tape. |
| 6 | Load the tape following the standard procedure. |
| 7 | The following dialogue is now generated where user responses are underlined. The calibration source parameters are site dependent and must be known beforehand. |

Run CAL55

Do you have an input tape? No
Is system control in standby? No
Set system control to standby
Is system control in standby? Yes
*Start system control
Range = 200 PRF = 100
Do you wish to change any parameters? No
Is the CPME on? Yes
Do you wish a monopulse calibration? Yes

Enter antenna beamwidth in degrees 2.2
Enter duration of cal. run in minutes 15
Enter range of cal. source in NMI. 5.5
Enter azimuth of cal. source in deg. 4.3
Enter code bits of cal. source in octal 165274
Enter altitude bits of cal. source in octal 012414

* System control is started by placing the trigger source switch to the EXT position if slaved to another transmitter, or INT if on own transmitter.

This ends the initial calibration process dialogue. During the time the system is calibrating, the user should dismount the calibration system tape per the dismount instructions and mount a parameter tape with a write ring in the hub.

When the calibration completes the system responds with, DO YOU WANT PLOT? A YES answer will plot the monopulse curve on the LA36 DECwriter. The plot consists of 256 print lines and represents the average monopulse correction value for each reference A/D cell. Any other answer will not generate the plot.

The next system response is, DO YOU WANT DIFFERENCE TABLE? A YES response will print another 256 lines of azimuth difference vs monopulse sample cell. Any other answer will not print those lines. The system then asks, IS PARAMETER TAPE READY? The user should then perform the dismount and mount of tape if they were not done earlier, and answer YES.

The processor will then proceed to write on the parameter tape.

Caution: Be sure tape is write enabled. (i.e., write ring in the hub).

After the tape completes writing, the system responds with CAL55---STOP. The calibration is now completed and the parameter tape may be dismounted.

The preceding was a dialogue in which no parameters were changed. The following is an example of dialogue where certain parameters were changed, but no calibration was performed. Follow steps 1 through 6 in the preceding section. Then follow this dialogue.

Run CAL55

Do you have an input tape? No
Is system control in standby? No
Set system control to standby
Is system control in standby? Yes
Start system control
Range = 200 PRF = 100
Do you wish to change any parameters? Yes
Enter scan time in seconds -- default = 12*
Enter number of sectors -- 4.8.16.32 -- default = 15*
Enter cone angle (deg. from hor.) -- default = 60*
Do you wish to change false-target values? Yes
Enter number of false-targets (max=10) 8
Enter start az..end az..distance, orientation angle
Four decimal values (separate with commas)

* Note: The operator must enter a value for these responses, else the input is taken as 0 and incorrect results may occur.

1. 0.0,15.0,0.25,255.44
2. 122.0,124.0,1.16,209.056
3. 220.0,222.0,14.5,330.701
4. 281.0,294.0,1.556,339.868
5. 294.0,310.0,0.99,187.256
6. 312.0,319.0,1.528,316.677
7. 324.0,327.0,1.137,325.667
8. 322.0,360.0,0.45,256.094

Is the CPME on? Yes
 Do you wish a monopulse calibration? No
 Is parameter tape ready? Yes
 CAL55 -- Stop

11.2 Surveillance Processing

This process performs the data taking, report declaration, target correlation, tracking, and report dissemination functions.

| <u>Step</u> | <u>Procedure</u> |
|-------------|--|
| 1 | Set trigger source switch on AMPS rack to standby. |
| 2 | Insure that azimuth wedge select switch inside rack door is off. |
| 3 | Set PRF or + N to desired value. |
| 4 | Set Range NM to desired value. |
| 5 | Mount AMPS surveillance system tape. |
| 6 | Load the tape following the standard procedure. |
| 7 | Once system is booted (i.e., responds with RSX-11S Vol BL12), dismount system tape. |
| 8 | Mount a parameter tape (without a ring) which was created in a calibration process. |
| 9 | Set desired output switches (MEGATEK, ARTS, NAS). See Note 1. |
| 10 | Type "RUN BOB55". This reads in the parameter tape. |
| 11 | When parameter tape stops, dismount it, and without too long a delay mount a blank tape with a write ring. See Note 2. |
| 12 | Set TRIGGER SOURCE SWITCH to INT or EXT. |

The AMPS system is now running with data being recorded and transmitted to the external interfaces selected.

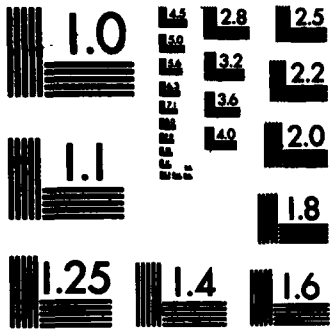

MICROCOPY RESOLUTION TEST CHART
NATIONAL BUREAU OF STANDARDS-1963-A

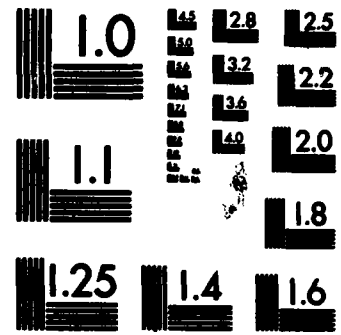

MICROCOPY RESOLUTION TEST CHART
NATIONAL BUREAU OF STANDARDS-1963-A

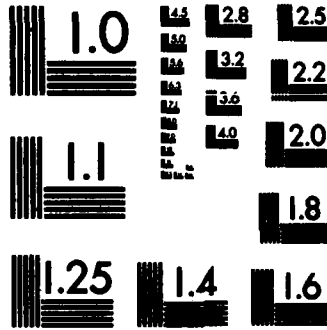

MICROCOPY RESOLUTION TEST CHART
NATIONAL BUREAU OF STANDARDS-1963-A

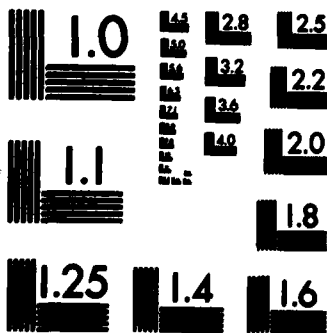

MICROCOPY RESOLUTION TEST CHART
NATIONAL BUREAU OF STANDARDS-1963-A

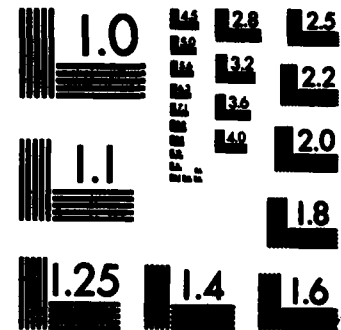

MICROCOPY RESOLUTION TEST CHART
NATIONAL BUREAU OF STANDARDS-1963-A

Note 1: Switches are labeled on the Front Panel.

Note 2: The AMPS processor has a 2-minute time-out between the time the parameter tape is read and the time the trigger source switch must be thrown out of standby.

11.2.1 AMPS Control

Once the AMPS system is operating there are certain control features available to the user, as well as a procedure to stop the processing.

A. Control Features

The Range NM and PRF or + N controls may be set to the user's specifications. The Trigger Source Switch is used to start/suspend the processing. If this switch is placed in the STANDBY position during a run, processing will suspend and the two control switches may then be reset to other values if desired. Once the new values have been dialed up, the Trigger Source Switch may then be returned to the INT or EXT position to continue processing.

Example: Assume the system is running with 200 NM, a + N of 3, and the Trigger Source Switch in EXT. The user then wishes to change the range to 100 NM and a + N of 2. The following steps will accomplish this.

| <u>Step</u> | <u>Procedure</u> |
|-------------|---|
| 1 | Place Trigger Source in Standby. (Processing suspends). |
| 2 | Set desired Range and + N (i.e., 100 NM and 2). |
| 3 | Reset Trigger Source Switch to EXT. (Processing continues). |

B. Stopping the Processor

When the user wishes to terminate the processor, Steps 1 through 3 of A. are followed except that in Step 2 the + N should be set to 99.

The processor will create in EOF on the tape and an indication that tasks BOB55 and UPDATE have stopped. The tape may then be dismounted.

Should the user wish to make subsequent runs, he must perform steps 1 through 12 under Surveillance Processing.

11.3 Post-Run Evaluation Process

After an SDP format tape has been produced by AMPS, it may become desirable to get some immediate measure of the system's performance. In particular, this will permit the rerunning of an experiment without delay or setup work if some problem has arisen the first time. The post-processor program described here serves that purpose. It can quickly verify the operation of AMPS and give a measure of quality of the system. The statistics used by this process to generate its results were placed on the output tape at the conclusion of the AMPS run, just prior to the EOF.

The steps necessary to run this process are as follows:

| <u>Step</u> | <u>Procedure</u> |
|-------------|--|
| 1 | Mount AMPS quick-look processing system tape. |
| 2 | Load the tape into the 11/55 following the standard procedure. |
| 3 | Remove the tape once the system is booted. |
| 4 | Mount an AMPS output tape without a write ring. |
| 5 | Type RUN BOBTES. |

11.3.1 Post-Processor Output

The following figures illustrate the output of the post-processor on a test database. The values shown are not necessarily typical of a real AMPS run. The outputs are shown in order, but are separated to allow explanatory text to be interspersed.

The first output is a set of parameters. CONNGL refers to the cone-of-silence angle of the sensor. KAY is the number of misses which will cause a track to be dropped. KPRF is the master PRF (pulse-repetition frequency) which is used only when AMPS is slaved to another sensor. NOBST is the number of false-target reflectors in the system. NSEC is the number of azimuth sectors in use. NVEL is the nominal aircraft velocity to be expected, given in knots. SCANT is the scan time in seconds. RBWDTH is the antenna beamwidth in degrees.

The second output of the post-processor is the set of false-target parameters. If no false-targets are in the system, then this output will not be generated.

The third output is the monopulse table, in units of 186 counts per degree of correction. Each row gives eight table entries. If the entire row has values 32000 (no valid monopulse), then DFAULT is printed.

RUN BOBTES

PARAMETERS OF RUN

| CONNGL | KAY | KPRF | NOBST | NSEC | NVEL | SCANT | RBWDTH |
|--------|-----|------|-------|------|------|-------|--------|
| 60 | 3 | 0 | 8 | 16 | 400 | 12 | 2.20 |

| FALSE TARGETS--- | START AZ. | END AZ. | RANGE | ANGLE |
|------------------|-----------|---------|-------|--------|
| | 0.00 | 15.00 | 0.25 | 255.44 |
| | 122.00 | 124.00 | 1.16 | 209.06 |
| | 220.00 | 222.00 | 14.50 | 330.70 |
| | 281.00 | 294.00 | 1.56 | 339.87 |
| | 294.00 | 310.50 | 0.99 | 187.26 |
| | 312.00 | 319.00 | 1.53 | 316.68 |
| | 324.00 | 327.00 | 1.14 | 325.37 |
| | 332.00 | 360.00 | 0.45 | 256.09 |

MONOPULSE TABLE

| | | | | | | | | | |
|-----|---------|-------|-------|-------|-------|-------|-------|-------|--|
| 1 | DEFAULT | | | | | | | | |
| 9 | DEFAULT | | | | | | | | |
| 17 | DEFAULT | | | | | | | | |
| 25 | 32000 | 32000 | 32000 | 32000 | 32000 | 32000 | -217 | -214 | |
| 33 | -212 | -210 | -209 | -205 | -203 | -201 | -199 | -197 | |
| 41 | -194 | -192 | -190 | -188 | -185 | -183 | -181 | -179 | |
| 49 | -176 | -174 | -172 | -170 | -167 | -165 | -163 | -161 | |
| 57 | -158 | -156 | -154 | -152 | -150 | -147 | -145 | -143 | |
| 65 | -141 | -138 | -136 | -134 | -132 | -129 | -127 | -125 | |
| 73 | -123 | -120 | -118 | -116 | -114 | -111 | -109 | -107 | |
| 81 | -105 | -102 | -100 | -98 | -96 | -94 | -91 | -89 | |
| 89 | -87 | -85 | -82 | -80 | -78 | -76 | -73 | -71 | |
| 97 | -69 | -67 | -64 | -62 | -60 | -58 | -55 | -53 | |
| 105 | -51 | -49 | -47 | -44 | -42 | -40 | -39 | -35 | |
| 113 | -33 | -31 | -29 | -26 | -24 | -22 | -20 | -17 | |
| 121 | -15 | -13 | -11 | -8 | -6 | -4 | -2 | 0 | |
| 129 | 2 | 4 | 6 | 8 | 11 | 13 | 15 | 17 | |
| 137 | 20 | 22 | 24 | 26 | 29 | 31 | 33 | 35 | |
| 145 | 38 | 40 | 42 | 44 | 47 | 49 | 51 | 53 | |
| 153 | 55 | 58 | 60 | 62 | 64 | 67 | 69 | 71 | |
| 161 | 73 | 76 | 78 | 80 | 82 | 85 | 87 | 89 | |
| 169 | 91 | 94 | 96 | 98 | 100 | 102 | 105 | 107 | |
| 177 | 109 | 111 | 114 | 116 | 118 | 120 | 123 | 125 | |
| 185 | 127 | 129 | 132 | 134 | 136 | 138 | 141 | 143 | |
| 193 | 145 | 147 | 150 | 152 | 154 | 156 | 158 | 161 | |
| 201 | 163 | 165 | 167 | 170 | 172 | 174 | 176 | 179 | |
| 209 | 181 | 183 | 185 | 188 | 190 | 192 | 194 | 197 | |
| 217 | 199 | 201 | 203 | 205 | 208 | 210 | 212 | 214 | |
| 225 | 217 | 32000 | 32000 | 32000 | 32000 | 32000 | 32000 | 32000 | |
| 233 | DEFAULT | | | | | | | | |
| 241 | DEFAULT | | | | | | | | |
| 249 | DEFAULT | | | | | | | | |

The post-processor will next output the CPME (calibration source) parameters, if one is in use. Its range in nautical miles, azimuth in degrees, mode 3/A code, altitude and mode 2 code will be given. The codes are given in octal, other values in decimal.

The maximum track number is given next. Following this may come debugging values, if debug parameters were used in the AMPS run. These indicate artificial time delays in various parts of the processing program. Next comes the sensor range, PRF, and mode. These values are those read from the AMPS hardware switches. Mode 1 implies internal mode, Mode 0 implies external (slaved) operation. An indication of the state of the CPME may follow. A lock failure at start-up is allowed, but further failures may indicate trouble. The first number printed is the mission time in milliseconds, the second number is the scan. A lock failure on scan 6 is normal.

CPME PARAMETERS

RANGE = 5.50 AZIM = 4.30 CODE = 7253 ALT = 500 MODE 2 = 0
 TRACK NUMBER LIMIT = 251
 DEBUG VALUE 3 = 0 0 300
 SENSOR RANGE = 300.00 RANGE
 PRF = 62
 MODE = 1
 CPME OSC. LOCK FAILURE AT 158532155 SCAN = 6

The next output of the post-processor is a matrix of timing values for the reply correlator process. Each row indicates the number of completed targets formed during the sweep processing, while each column indicates the number of new replies processed during the sweep. Each entry consists of two numbers; the top value is the number of milliseconds required for reply correlation, and the lower number is the number of times that this case occurred during the run.

REPLY CORRELATOR...AVERAGE SWEEP TIMES IN MSECS

| TARGETS | NO. OF REPLIES | | | | | | | | | | |
|---------|----------------|-------------|-------------|-------------|-------------|------------|------------|------------|------------|-----------|----------|
| | 0 | 1 | 2 | 3 | 4 | 5 | 6 | 7 | 8 | 9 | 10 |
| 0 | 2.3 11295 | 4.1 7863 | 5.2 6136 | 6.4 2903 | 7.4 1116 | 8.6 445 | 9.8 133 | 10.8 34 | 11.8 11 | 11.1 7 | 0.0 0 |
| 1 | 3.5 2400 | 4.7 2178 | 5.9 1156 | 7.1 629 | 8.2 278 | 9.2 78 | 9.9 23 | 11.2 4 | 14.0 1 | 11.5 2 | 0.0 0 |
| 2 | 4.0 200 | 5.1 2.5 | 6.3 150 | 7.5 84 | 8.6 27 | 9.8 13 | 10.0 1 | 11.0 1 | 11.0 1 | 0.0 0 | 0.0 0 |
| 3 | 3.8 9 | 5.8 16 | 7.1 9 | 8.7 6 | 10.0 4 | 0.0 0 | 0.0 0 | 0.0 0 | 0.0 0 | 0.0 0 | 0.0 0 |
| 4 | 0.0 0 | 6.7 3 | 7.0 1 | 9.0 1 | 0.0 0 | 0.0 0 | 0.0 0 | 0.0 0 | 0.0 0 | 0.0 0 | 0.0 0 |
| 5 | 0.0 0 | 0.0 0 | 9.0 1 | 0.0 0 | 0.0 0 | 0.0 0 | 0.0 0 | 0.0 0 | 0.0 0 | 0.0 0 | 0.0 0 |
| 6 | 0.0 0 | 0.0 0 | 0.0 0 | 0.0 0 | 0.0 0 | 0.0 0 | 0.0 0 | 0.0 0 | 0.0 0 | 0.0 0 | 0.0 0 |
| 7 | 0.0 0 | 0.0 0 | 0.0 0 | 0.0 0 | 0.0 0 | 0.0 0 | 0.0 0 | 0.0 0 | 0.0 0 | 0.0 0 | 0.0 0 |
| 8 | 0.0 0 | 0.0 0 | 0.0 0 | 0.0 0 | 0.0 0 | 0.0 0 | 0.0 0 | 0.0 0 | 0.0 0 | 0.0 0 | 0.0 0 |
| 9 | 0.0 0 | 0.0 0 | 0.0 0 | 0.0 0 | 0.0 0 | 0.0 0 | 0.0 0 | 0.0 0 | 0.0 0 | 0.0 0 | 0.0 0 |
| 10 | 0.0 0 | 0.0 0 | 0.0 0 | 0.0 0 | 0.0 0 | 0.0 0 | 0.0 0 | 0.0 0 | 0.0 0 | 0.0 0 | 0.0 0 |

The next output is a set of statistics on AMPS performance for the entire run. These statistics indicate the loading on the processor and the amount of data lost due to lack of processing time.

THERE WERE 50121 AVAILABLE REPLIES OF WHICH 50118 WERE PROCESSED.

THERE WERE 8286 TARGETS FORMED OF WHICH 8207 WERE PROCESSED.

THERE WERE 982 SECTORS PROCESSED THE BREAKDOWN IS AS FOLLOWS:

472 ON TIME
 435 SLIGHTLY LATE
 63 VERY LATE
 12 DROPPED

NO. OF SWEEPS = 48884 SWEEPS INTERRUPTED = 1

The next output of the post-processor is a set of times for the correlation and tracking tasks in AMPS. The columns are determined by the number of targets being processed, the row is determined by the subtask routine. DISCO performs discrete-code algorithms. ASSCID performs association of targets and tracks. CORREL performs correlation of targets with tracks. TRACKN performs track initialization. TUP performs track update. Each entry consists of a time per target and the number of occurrences of the case.

ASSOCIATION AND TRACKING...AVERAGE TIMES IN MSECS

| ROUTINE | NO. OF TARGETS | | | | | | | | |
|---------|----------------|------|------|------|-------|-------|-------|-------|-------|
| | 0 | 1 | 2-5 | 6-10 | 11-15 | 16-20 | 21-25 | 26-30 | 31-35 |
| DISCO | 2.2 | 4.5 | 2.5 | 2.0 | 1.6 | 1.6 | 1.5 | 1.2 | 0.0 |
| | 47 | 28 | 285 | 355 | 132 | 86 | 51 | 1 | 0 |
| ASSCID | 11.3 | 42.0 | 11.6 | 6.7 | 5.7 | 4.7 | 3.5 | 3.2 | 0.0 |
| | 47 | 28 | 170 | 330 | 132 | 86 | 51 | 1 | 0 |
| CORREL | 4.2 | 13.2 | 2.5 | 2.0 | 1.0 | 1.7 | 1.0 | 0.1 | 0.0 |
| | 47 | 28 | 285 | 355 | 132 | 86 | 51 | 1 | 0 |
| TRACKN | 14.2 | 31.2 | 13.2 | 0.2 | 6.6 | 6.5 | 5.6 | 4.7 | 0.0 |
| | 47 | 28 | 285 | 355 | 132 | 86 | 51 | 1 | 0 |
| TUP | 14.2 | 31.2 | 13.2 | 8.2 | 6.6 | 6.5 | 5.6 | 4.7 | 0.0 |
| | 47 | 28 | 168 | 270 | 132 | 86 | 51 | 1 | 0 |

At the end of the printout the post-processor program will list several summary data blocks. The first is the collected set of data from the performance-monitor hardware. The mean, standard deviation, maximum, and minimum of each measured value is given. The maximum and minimum values are sometimes scaled by a factor of ten differently than the mean values.

PERFORMANCE MONITOR DATA

| | MEAN | STD. DEV. | MAXIMUM | MINIMUM |
|------------------|----------|-----------|---------|---------|
| P1 POWER (WATTS) | 1786.034 | 237.014 | 185 | 0 |
| P2 POWER (WATTS) | 107.586 | 14.421 | 11 | 0 |
| SUM (DB.) | 50.121 | 6.639 | 50 | 0 |
| OMNI (DB.) | 49.138 | 6.508 | 50 | 0 |
| DELTA/SUM+ (DEG) | 1.983 | 0.265 | 21 | 0 |
| DELTA/SUM- (DEG) | 1.867 | 0.247 | 19 | 0 |
| DELTA/SUMO (DEG) | 0.000 | 0.000 | 0 | 0 |
| OMNI NOISE (MV) | 350.517 | 53.124 | 13 | 0 |
| SUM NOISE (MV) | 190.690 | 46.752 | 29 | 0 |
| SCAN INT. (SEC) | 11.903 | 0.013 | 11910 | 0 |

The next data block is the active range for each sector. Overloading AMPS will cause a reduction in the active range for those sectors which are falling behind. The active range is given as a fraction of the sensor range setting of the hardware. The mean, standard-deviation, maximum and minimum values are given. Again, the maximum and minimum values are scaled differently, this time by a factor of 100.

ACTIVE RANGES AS FRACTION OF SENSOR RANGE

| | | | | | |
|--------|---|-------|-------|-----|-----|
| SECTOR | 1 | 0.696 | 0.113 | 91 | 32 |
| SECTOR | 2 | 0.450 | 0.079 | 75 | 10 |
| SECTOR | 3 | 0.990 | 0.023 | 100 | 7 |
| SECTOR | 4 | 0.933 | 0.075 | 100 | 90 |
| SECTOR | 5 | 1.000 | 0.000 | 100 | 100 |
| SECTOR | 6 | 0.998 | 0.009 | 100 | 95 |
| SECTOR | 7 | 1.000 | 0.000 | 100 | 100 |

| | | | | | |
|--------|----|-------|-------|-----|-----|
| SECTOR | 8 | 1.000 | 0.000 | 100 | 100 |
| SECTOR | 9 | 0.766 | 0.057 | 100 | 61 |
| SECTOR | 10 | 0.999 | 0.005 | 100 | 97 |
| SECTOR | 11 | 0.311 | 0.177 | 91 | 12 |
| SECTOR | 12 | 0.804 | 0.070 | 95 | 50 |
| SECTOR | 13 | 0.201 | 0.180 | 90 | 1 |
| SECTOR | 14 | 0.405 | 0.172 | 90 | 16 |
| SECTOR | 15 | 0.553 | 0.064 | 70 | 16 |
| SECTOR | 16 | 0.201 | 0.172 | 90 | 12 |

The next data block contains the summary of the pseudo target data. The pseudo target is a product of the AMPS hardware which is artificially produced each scan at a fixed range and azimuth. The spread of its measured range and azimuth is a measure of AMPS performance. Again, the mean, standard-deviation, maximum and minimum values are given. The maximum and minimum ranges are in AMPS range-counts (LSB = 1/256 of a nautical mile). The maximum and minimum azimuths are in AMPS units (65536 counts = 360 degrees).

FOLLOWING ARE PSEUDO TARGET VALUES

| | | | | |
|----------------|-------|-------|------|---|
| RANGE (MILES) | 0.738 | 1.602 | 2300 | 0 |
| AZIMUTH (DEG) | 0.768 | 0.196 | 180 | 0 |
| REPLIES/TARGET | 3.661 | 0.303 | 0 | 0 |
| TARGETS/SCAN | 1.876 | 0.673 | 5 | 0 |

The next data block is the summary of the CPME data. The difference of the measured range and azimuth from the given values is computed. The mean, standard-deviation, maximum and minimum values are given. The maximum and minimum values for range and azimuth differences are in AMPS units, like the pseudo target data above.

FOLLOWING ARE CPME VALUES

| | | | | |
|---------------------|--------|--------|-------|--------|
| RANGE DIFF. (MI) | -0.105 | 0.831 | 3 | -1604 |
| AZIMUTH DIFF. (DEG) | 1.408 | 27.120 | 32288 | -10057 |
| REPLIES/TARGET | 5.375 | 0.614 | 6 | 3 |
| TARGETS/SCAN | 5.411 | 1.685 | 9 | 2 |

The final data block produced by the post-processor program is a set of per scan performance values. The mean, standard-deviation, maximum and minimum value are printed for each data item. Hardware replies refers to the number of replies present at the AMPS hardware before any processing. Software replies refers to replies transferred to the software buffer in the

input routine. Buffered replies refers to replies which were transferred to the reply correlation (target formation) routines. Processed replies refers to those replies which were actually used in target formation. Successive reductions between these categories reflect data loss due to various possible overload conditions.

Next, target reports refers to the number of reports formed. Used reports are those reports actually passed to target correlation and tracking. The difference is reports dropped due to system delays.

Sweeps is the number of sweeps of data input to the system. Complete sweeps are those sweeps which had time to be completely processed without interruption. Deleted sweeps are those not processed at all.

Idle time is the amount of time during a scan which was unused by the AMPS software. It is a measure of the loading on the total system.

On-time sectors are those processed without delay. Late sectors are those which are being processed up to one-half sector after their proper time. Very late sectors are those being processed up to a full sector after their proper time. Deleted sectors are those not processed at all.

Finally, tracks is the number of aircraft in the system. Blip scan is the probability that the replies produced by any aircraft will be formed into a target report. (This value appears low because of the misses occurring when an aircraft leaves coverage).

FOLLOWING ARE COMPUTED PER SCAN

| | | | | |
|-------------------|----------|----------|-------|-----|
| HARDWARE REPLIES | 1042.399 | 19.788 | 1163 | 968 |
| SOFTWARE REPLIES | 972.679 | 41.017 | 1094 | 856 |
| BUFF REPLIES | 831.696 | 43.371 | 961 | 737 |
| PROC. REPLIES | 831.643 | 43.409 | 961 | 737 |
| TARGET REPORT | 137.482 | 7.780 | 151 | 123 |
| USED REPORTS | 136.839 | 8.838 | 151 | 103 |
| SWEEPS | 793.268 | 8.874 | 819 | 762 |
| COMPLETE SWEEPS | 793.232 | 8.878 | 819 | 762 |
| DEL. SWEEPS | 0.036 | 0.136 | 1 | 0 |
| IDLE TIME (MSEC) | 1268.448 | 1870.153 | 15265 | 277 |
| ON-TIME SECTORS | 7.429 | 2.017 | 12 | 3 |
| LATE SECTORS | 7.446 | 1.851 | 11 | 2 |
| VERY LATE SECTORS | 1.016 | 1.923 | 8 | 0 |
| DEL. SECTORS | 0.107 | 0.582 | 4 | 0 |
| TRACKS | 135.107 | 5.650 | 152 | 122 |
| BLIP SCAN | 0.711 | 0.045 | 97 | 72 |

11.4 Playback Process

This process reads an AMPS output tape created by a previous run and once again outputs the surveillance reports to external facilities.

| <u>Step</u> | <u>Procedure</u> |
|-------------|--|
| 1 | Set trigger source which on AMPS rack to standby. |
| 2 | Mount the PLYBCK program tape. |
| 3 | Load the tape following the standard procedure. |
| 4 | Set sense switch for appropriate output facility, (MEG, NAS, ARTS). |
| 5 | Dismount the PLYBCK program tape and mount an AMPS data tape without a ring. |
| 6 | Type "RUN PLYBCK" on the LA36. The playback program is now operating. |
| 7 | To halt execution, depress the halt switch on the operator's console. |

11.5 DR11-K Diagnostic

This diagnostic program exercises the DR11-K interface between the AMPS reply processor hardware and the 11/55 computer. The program can request a series of words from the interface and print them out on the system console. Each word represents one interrupt from the hardware. To run the DR11-K diagnostic, use the following procedure:

| <u>Step</u> | <u>Procedure</u> |
|-------------|--|
| 1 | Mount the calibration program tape. |
| 2 | Load the tape following the standard procedure. |
| 3 | Invoke the diagnostic program with the command: RUN KTEST. |
| 4 | Set the trigger source switch to the appropriate run mode (internal/external). |
| 5 | Enter the number of words to print when prompted to do so. This number should be between 1 and 1000. |
| 6 | The program will now print a sequence of DR11-K words. |
| 7 | Set the trigger source switch to standby. This will stop the program. |
| 8 | Abort the program with the command: ABO KTEST. |

The following page is a printout taken from an actual keyboard session.

170017 000000 000552 003400

MT

RSX-11S VO1 BL12

RUN KTEST

ENTER MAX OF BUFFER IN 13 FORMAT

10

1BUF -

| | | | | |
|--------|--------|--------|--------|--------|
| 105400 | 105400 | 105400 | 105400 | 105400 |
|--------|--------|--------|--------|--------|

| | | | | |
|--------|--------|--------|--------|--------|
| 105400 | 105400 | 105400 | 105400 | 105400 |
|--------|--------|--------|--------|--------|

1BUF -

| | | | | |
|--------|--------|--------|--------|--------|
| 105400 | 105400 | 105400 | 105400 | 105400 |
|--------|--------|--------|--------|--------|

| | | | | |
|--------|--------|--------|--------|--------|
| 105400 | 105400 | 105400 | 105400 | 105400 |
|--------|--------|--------|--------|--------|

1BUF -

| | | | | |
|--------|--------|--------|--------|--------|
| 105400 | 105400 | 105400 | 105400 | 105400 |
|--------|--------|--------|--------|--------|

| | | | | |
|--------|--------|--------|--------|--------|
| 105400 | 105400 | 105400 | 105400 | 105400 |
|--------|--------|--------|--------|--------|

1BUF -

| | | | | |
|--------|--------|--------|--------|--------|
| 105400 | 105400 | 105400 | 105400 | 105400 |
|--------|--------|--------|--------|--------|

| | | | | |
|--------|--------|--------|--------|--------|
| 105400 | 105400 | 105400 | 105400 | 105400 |
|--------|--------|--------|--------|--------|

ABO KTEST

11.6 DR11-B Diagnostic

This diagnostic program exercises the DR11-B interface which connects the AMPS reply processor hardware with the computer. The program can control self-test facilities in the hardware by setting "function bits". These three function bits are represented as a single octal digit. The eight possible test modes are divided into two classes: modes 0 through 3 do use the hardware FIFO logic, and modes 4 through 7 do not use the FIFO. Otherwise, these modes are identical. Test mode 0 (or 4) passes replies, the other modes pass fixed data fields. Sample data corresponding to each mode are as follows:

| | | | | | |
|----------|--------|----------|---------------------------|----------|--------|
| <u>0</u> | 003462 | | Range = 9 miles | | |
| | 013414 | | Code = 170C ₁₆ | | |
| | 000424 | | Azimuth = 1.518 degrees | | |
| | 177777 | | Flag = all ones | | |
| | 170020 | | Mode | | |
| | 006400 | } | Special Conditions | | |
| | 030000 | | | | |
| | 000000 | | | | |
| <u>1</u> | 000000 | <u>2</u> | 052525 | <u>3</u> | 000001 |
| | 177777 | | 125252 | | 000002 |
| | 000000 | | 052525 | | 000003 |
| | 177777 | | 125252 | | 000004 |
| | 000000 | | 052525 | | 000005 |
| | 177777 | | 125252 | | 000006 |
| | 000000 | | 052525 | | 000007 |
| | 177777 | | 125252 | | 000010 |

Each of these data fields consists of eight 16-bit words, which may repeat as often as necessary. The diagnostic will print these patterns, eight words to a line, on the system console as shown on the next page. To run the DR11-B diagnostic, use the following procedure:

017170 000000 000574 000000
\$MT
RSX-11S VOL BL12

>RUN BTEST

>

ENTER FUNCTION BITS (01)

0

ENTER REPLY COUNT (I2)

2

| | | | | | | | |
|--------|--------|-------|--------|--------|--------|-------|--------|
| 176300 | 177777 | 32360 | 177777 | 140000 | 177777 | 30777 | 177777 |
| 0 | 0 | 0 | 0 | 0 | 0 | 0 | 0 |

ENTER FUNCTION BITS (01)

1

ENTER REPLY COUNT (I2)

2

| | | | | | | | |
|---|---|--------|--------|---|---|--------|--------|
| 0 | 0 | 177777 | 177777 | 0 | 0 | 177777 | 177777 |
| 0 | 0 | 177777 | 177777 | 0 | 0 | 177777 | 177777 |

ENTER FUNCTION BITS (01)

2

ENTER REPLY COUNT (I2)

2

| | | | | | | | |
|-------|-------|--------|--------|-------|-------|--------|--------|
| 52525 | 52525 | 125252 | 125252 | 52525 | 52525 | 125252 | 125252 |
| 52525 | 52525 | 125252 | 125252 | 52525 | 52525 | 125252 | 125252 |

ENTER FUNCTION BITS (01)

3

ENTER REPLY COUNT (I2)

5

| | | | | | | | |
|---|---|---|---|---|---|----|----|
| 1 | 1 | 2 | 2 | 3 | 3 | 4 | 4 |
| 5 | 5 | 6 | 6 | 7 | 7 | 10 | 10 |
| 1 | 1 | 2 | 2 | 3 | 3 | 4 | 4 |
| 5 | 5 | 6 | 6 | 7 | 7 | 10 | 10 |
| 1 | 1 | 2 | 2 | 3 | 3 | 4 | 4 |

ENTER FUNCTION BITS (01)

9

BTEST -- EXITING DUE TO ERROR 64

INPUT CONVERSION ERROR

IN ".MAIN." AT OR AFTER 7

| <u>Step</u> | <u>Procedure</u> |
|-------------|---|
| 1 | Mount calibration program tape with the DR11-B diagnostic. |
| 2 | Load the tape following standard procedure. |
| 3 | Invoke the diagnostic program with the command: RUN BTEST. |
| 4 | Enter the function bits (test mode) when prompted to do so. This should be a number between 0 and 7. |
| 5 | Set the trigger source switch on the AMPS rack to the appropriate run mode (internal/external). |
| 6 | Enter the number of replies (8-word blocks) desired when prompted to do so. |
| 7 | The program will print the DR11-B output on the system console and return to step 4. Step 5 need not be repeated. |

11.7 Sweep Dump Diagnostic

This diagnostic program allows AMPS to type reply data on the system console in the format of the AMPS hardware. Up to 100 sweeps of data may be dumped at one time. Each sweep of data is printed as follows (see next page):

1. sweep number (1 through 99) and DR11-K status word (octal)
2. sweep header data (range, azimuth, etc.)
3. replies in sweep, if any. Range, code, azimuth, code flag (or altitude flag with altitude on mode C sweeps), monopulse, special-bit fields in octal. Mode of sweeps is printed as "A", "C", "2" for mode 3/A, mode C, and mode 2, respectively. Test targets are marked as mode "X". Sweep headers have a special marker field. The decoding register and N-bar (number of monopulse updates) fields are in decimal.

To run the sweep dump program, use the following procedure:

| <u>Step</u> | <u>Procedure</u> |
|-------------|---|
| 1 | Set trigger source switch on AMPS rack to standby. |
| 2 | Mount a system checkout program tape. |
| 3 | Load the tape following the standard procedure. |
| 4 | Invoke the sweep dumper program with the command: RUN SWEEP |
| 5 | Enter a sweep count when prompted to do so. This number should be between 1 and 99. |
| 6 | Set trigger source switch on AMPS rack to appropriate run mode (internal/external). Sweep data will be accumulated and when the desired number of sweeps have occurred, the printout will begin. The program will stop when the stored sweeps have been printed. Subsequent sweep dumps may be taken by reporting step 4 any desired number of times. |

141703 000000 000574 000000
\$MT
RSX-11S VO1 BL12

>RUN SWEEP
>
ENTER SWEEP COUNT (12)
5

***SWEEP 1 DR11K= 104144

| RANGE | CODE | AZIMUTH | FLAG | MODE | MONOP. | S-BITS | HEAD | DEC | OVFL | NB |
|--------|--------|---------|--------|------|--------|--------|------|-----|------|----|
| 176301 | 177777 | 32360 | 177777 | C | 377 | 0 | 0 | 0 | 0 | 0 |

***SWEEP 2 DR11K= 104144

| RANGE | CODE | AZIMUTH | FLAG | MODE | MONOP. | S-BITS | HEAD | DEC | OVFL | NB |
|--------|--------|---------|--------|------|--------|--------|------|-----|------|----|
| 176300 | 177777 | 32360 | 177777 | A | 377 | 0 | 1 | 0 | 0 | 0 |

***SWEEP 3 DR11K= 104144

| RANGE | CODE | AZIMUTH | FLAG | MODE | MONOP. | S-BITS | HEAD | DEC | OVFL | NB |
|--------|--------|---------|--------|------|--------|--------|------|-----|------|----|
| 176300 | 177777 | 32360 | 177777 | C | 377 | 0 | 1 | 0 | 0 | 0 |

***SWEEP 4 DR11K= 104144

| RANGE | CODE | AZIMUTH | FLAG | MODE | MONOP. | S-BITS | HEAD | DEC | OVFL | NB |
|--------|--------|---------|--------|------|--------|--------|------|-----|------|----|
| 176300 | 177777 | 32360 | 177777 | A | 377 | 0 | 1 | 0 | 0 | 0 |

***SWEEP 5 DR11K= 104144

| RANGE | CODE | AZIMUTH | FLAG | MODE | MONOP. | S-BITS | HEAD | DEC | OVFL | NB |
|--------|--------|---------|--------|------|--------|--------|------|-----|------|----|
| 176301 | 177777 | 32360 | 177777 | C | 377 | 0 | 1 | 0 | 0 | 0 |

11.8 Microprocessor Output Diagnostic

This diagnostic program sends a fixed set of messages to the microprocessor output channels in AMPS. The messages form a set of 16 stationary targets uniformly spaced in azimuth. Each target is located 100 miles out in range, with an altitude of 600 feet, and with a code of EABC₁₆ (or 7253 octal). The timing of the program is set to send the 16 targets in roughly 8 seconds. The diagnostic may direct its output to any of the output channels. To run the output microprocessor diagnostic, use the following procedure:

| <u>Step</u> | <u>Procedure</u> |
|-------------|---|
| 1 | Mount "DRTEST" program tape. |
| 2 | Load the tape following the standard procedure. |
| 3 | Invoke the test program with the command: RUN DRTEST. |
| 4 | Enter the desired channel number when prompted to do so. There are three channels, numbered 1, 2, and 3. These numbers coincide with the rightmost three sense switches on the AMPS computer. |
| 5 | Enter a scan count when prompted to do so. This is the number of complete scans that will be sent. This number should be between 1 and 9999. |
| 6 | The channel will begin to send data. The program will stop when the desired number of scans have been sent out. |

160607 000000 000574 000000

\$MT
XDT: 12

XDT>
RSX-11S VO1 BL12

>RUN DRTEST

>

ENTER DEVICE NUMBER (1,2, OR 3)

2

ENTER NUMBER OF SCANS TO SEND

100

12. AMPS DISPLAY OPERATING PROCEDURES

The primary facility for displaying ATCRBS target reports from AMPS is through an interactive graphics system manufactured by MEGATEK. The system, depicted in Fig. 12-1, consists of a CRT with command keyboard and joystick, a Data General NOVA-3 minicomputer, two disk drives, and interactive display software. The control of the display is through the use of the NOVA 3 processor front panel switches, keyboard and joystick. The operating procedures in this chapter describe how to interact with the display and how to control the screen format.

12.1 Power Up

| <u>Step</u> | <u>Procedure</u> |
|-------------|---|
| 1 | Open the doors to both disk drives by pressing down on the black lever below each drive. |
| 2 | Turn the power switch key on the NOVA 3 processor to ON, the first position. All peripherals are controlled by this switch and should be on. |

To check for power:

1. The processor's front panel will light.
2. The disk drives will indicate power with red indicator lights. The power switch is in the upper right hand corner.
3. The display has an indicator light on the upper right hand corner of the display screen. The power switch is at the rear of the display.

12.2 Booting in the Program

| <u>Step</u> | <u>Procedure</u> |
|-------------|---|
| 1 | Set the front panel switch register to 100033 _g . |
| 2 | Place the program diskette into drive 0 and close the door. |
| 3 | Press down the STOP switch and then lift it up. |
| 4 | Lift up the PROGRAM LOAD switch. |
| 5 | The message "FILENAME" will be displayed. Respond with a carriage return. |
| 6 | In a few seconds the AMPS display box will appear. |

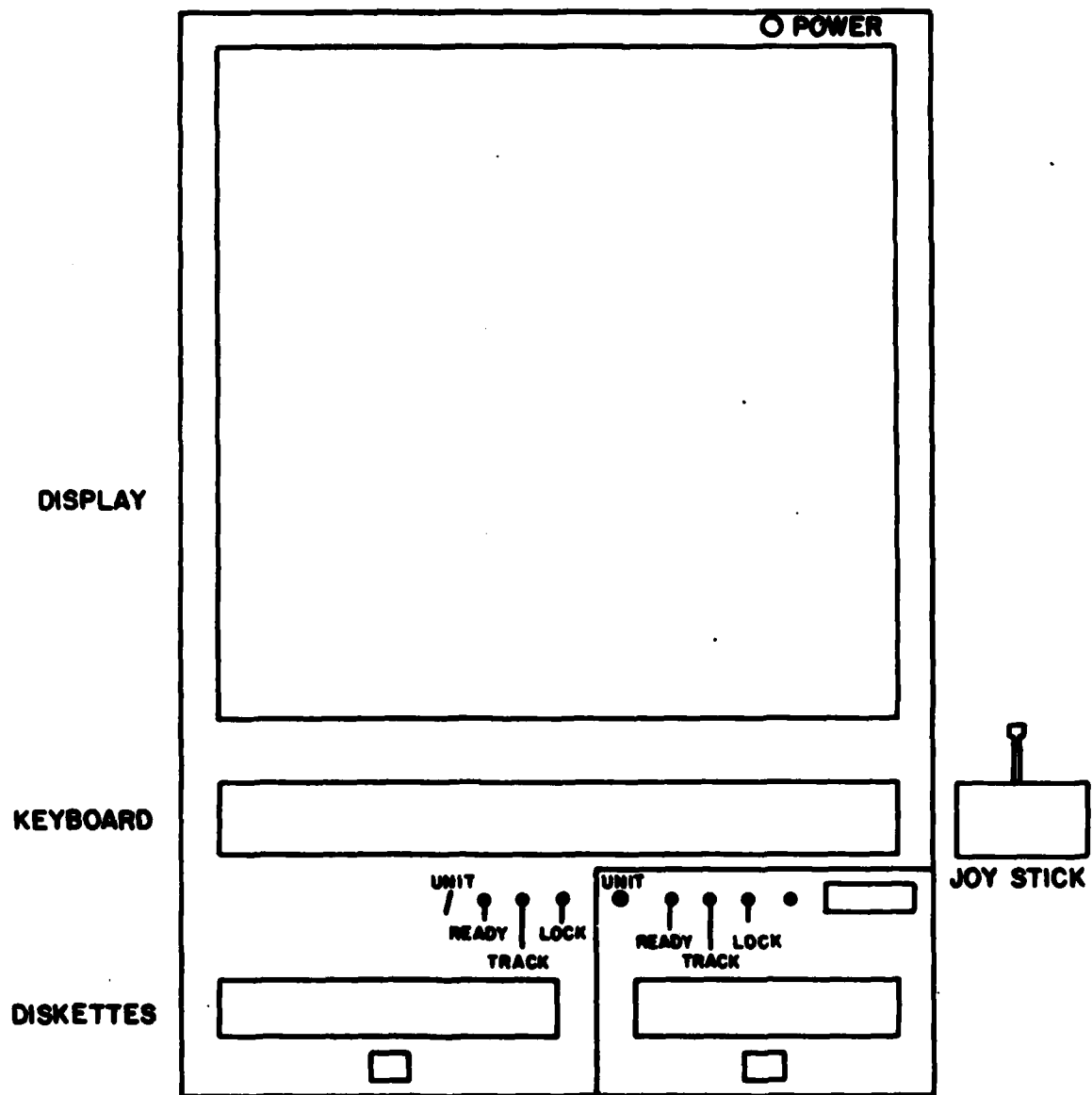

Fig. 12-1. MEGATEK Display.

12.3 Responses to the "PARAM?" Prompt in the Upper Left-Hand Corner

Parameters for certain display options may be set at this time, each followed by a carriage return. Other display options and controls are described in the next section. The parameters and their interpretations are:

- | | |
|-----------------------------|---|
| 1. Altitude use count | Reports with garbled altitudes will be displayed a parameter number of times. |
| 2. Coast count | An uncorrelated report will be displayed a parameter number of times. |
| 3. Histories | The number of past positions for reports may be selected to indicate aircraft movement. |
| 4. Real time clock | Time quantization. |
| 5. Range | The maximum range for the display may be set. |
| 6. Sectors | The number of azimuth sectors may be set. |
| 7. Maximum number of tracks | The maximum number of tracks that the system can handle at any one time may be set. |

The responses necessary to set up the parameters are as follows:

| <u>Action</u> | <u>Command</u> | <u>Result</u> |
|---------------------|----------------|--|
| Set ALT USE COUNT | Ad | Garbled altitude will be displayed up to "d" times Default = 3 |
| Set COAST COUNT | Cd | Default = 3 |
| Set HISTORIES | Hd | Default = 2; $2 < d < 6$ |
| Set REAL TIME CLOCK | Kd | $d = 1/10$'s sec; Default = 10 |
| Set RANGE | Rd | Default = 0; (200 nm), range = $200 * 2^{-d}$ |
| Set SECTORS | Sd | Default = 5 (32 sectors) Sectors = 2^d |
| Set MAX TRACKS | Td | Default = 257 $MXTRKS = MXTRKS + (d-5)*10$ e.g., $d = 0$ will reduce MXTRK by 50 NOTE: Can be repeated |

To run the program, respond with only a carriage return.

12.4 Responding to the "CMD?" Prompt in the Upper Left-Hand Corner

There are several options and controls available which enable the user to display reports as desired. Specific types of reports may be enabled or disabled for viewing. Correlated/uncorrelated, false, test, and a variety of edited-out target reports may be viewed or inhibited from the display. Reports may be tagged individually or collectively with code and altitude information. The individual or collective removal of these tags may also be done. The display of reports within a specified range box centered at the sensor may be chosen as well as report traffic in any off-center specified area within the maximum viewing range of the display. The display program may be reset at any time to full scale range, no tags, and only normal tracks displayed. Also, a full restart command may be given to get into the "PARAM?" initialization mode again.

| <u>Action</u> | <u>Command</u> | <u>Result</u> |
|---------------|----------------|---|
| Reset | R | Enables only normal tracks, full scale range, no tags |
| Enable Type | Ed | Enables display of specified type (see 12.4-2). |
| Inhibit Type | Id | Inhibits display of specified type (see 12.4-2). |
| Zoom | Z | Zooms to area specified by cursor lower left and upper right corners (see 12.4-3). |
| | Zd | Switches to specified range range = full scale *2 ^{-d} Range box shows area displayed on full scale display |
| Tag | T | Turns alternately on and off tagging of code and altitude on all reports |
| Restart | S | Restarts display program. Go back to PARAM? |
| Position | Pd | Tags and positions individual target picked by cursor (see 12.4-3) d sets one of 8 compass point positions for tag default, d = 0 for Northwest tag. |
| Clear | C | Removes tag of individual target (see 12.4-3) |

Follow each response by a carriage return.

12.4.1 Report Symbols

The display symbols for the various types of reports are given below.

| | <u>Present</u> | <u>History</u> | |
|--------|----------------|----------------|--|
| Normal | + | + | History symbols are smaller than Present ones |
| Coast | X | X | |
| False |] |] | |
| Radar | Γ | Γ | |

| | <u>Present</u> | <u>History</u> |
|--------------|----------------|----------------|
| Test | T | none |
| Edit-out | [| none |
| Uncorrelated | Π | none |

12.4.2 Display Types for E&I Commands

- 0 Normal
- 1 Edit-out SWAP candidate
- 2 Edit-out 1 hit
- 3 Edit-out Mode C only
- 4 Edit-out boresite
- 5 Edit-out 2 hit
- 6 Edit-out move to extra buffer
- 7 False
- 8 Uncorrelated target
- 9 Test target

12.4.3 Joystick Control

The zoom (magnification) feature of the AMPS display and the tagging of reports is under the combined control of the console keyboard and joystick. The procedures necessary for zooming and tagging are:

Zoom an area specified by cursor (crosshair).

| <u>Step</u> | <u>Procedure</u> |
|-------------|--|
| 1 | Type Z and a carriage return. |
| 2 | Position the cursor to the lower left of the desired viewing area, with the joystick, and press joystick button. |
| 3 | Position cursor to the upper right of the desired viewing area and press joystick button. |
| 4 | The reports within the area will be displayed in full screen. |

All responses to the "CMD?" prompt are now enabled including re-zooming to another area.

Tag a specific target with code and altitude information.

| <u>Step</u> | <u>Procedure</u> |
|-------------|--|
| 1 | Type P and a carriage return. |
| 2 | Position the cursor near the target to be tagged. |
| 3 | Press the joystick button. |
| 4 | The code and altitude will be displayed at the report. |

12.4.4 Tag Message

The tag message, which represents specific information for a report, is two words. The code and altitude of a report are given as well as a qualifying flag which describes the type of code or altitude according to the following.

Code: ddddS
Alt: Sddd

where: Code consists of:

dddd - 4 digit octal code

S - qualifying flag, set to

Blank - good code, high confidence
T - In transition, possible changing code
I - Improved by AMPS track
L - Low confidence bits in code

Alt consists of:

ddd - 3 digit decimal flight level in hundreds of feet.

Blank - No reply; not Mode C equipped.

000 - Brackets - Mode C equipped without encoding altimeter.

S - Qualifying flag

? - Display is last known level.

12.5 Use of Switch Register

Bit 1: If set, the program will display the status of the three tasks and statistics on the communications link as follows:

The display is on the bottom of the screen.

| | | | | | |
|------------------|------------------|------------------|-------------------------------------|--------------------------------|--|
| X | X | X | XXX | XX | XX |
| Status Task 1 | Status Task 2 | Status Task 3 | Count of Data Blocks Received | Count of Blocks In Error | Count of Sectors out of Sequence |

Note all numbers are octal.

| | | |
|--------------|---|------------------|
| Task Status: | 0 | Running |
| | 1 | Waiting for I/O |
| | 2 | Held |
| | 3 | Waiting |
| | 6 | Held and waiting |
| | 8 | Not in system |

Bit 4: If set, displays error messages as follows:

| | |
|-----------------|---|
| Error Messages: | Upper Right of screen |
| CL ERR | Parity or timing error in communications. |
| QUE SEC | No more room in sector or entry not found in expected sector. If 20, more untracked reports than entire. Value is octal of search sector. |
| TRK ERR | Correlating track number if greater than max track number. Value is octal of track number. |
| DISPLAY FULL | Tried to tag more reports than display has room for. Go to smaller zoom range. |
| *SEC ERR* | Reception of sectors out of sequence. |

REFERENCES

1. "FAA Engineering Requirement for Discrete Address Beacon System (DABS) Sensor" (22 April 1980), FAA-ER-240-26A.
2. J.L. Gertz, "The ATCRBS Mode of DABS," Project Report ATC-65, Lincoln Laboratory, M.I.T. (31 January 1977), FAA-RD-76-39.
3. D. Karp, M.L. Wood, "DABS Monopulse Summary", Project Report ATC-72, Lincoln Laboratory, M.I.T. (4 February 1977), FAA-RD-76-219.
4. R.G. Nelson, J.H. Nuckols, "A Hardware Implementation of the ATCRBS Reply Processor Used in DABS," Project Report ATC-78, Lincoln Laboratory, M.I.T. (19 September 1977), FAA-RD-77-92.

END