

TECHNICAL REPORT  
NATICK/TR-82/034

**AN INSTRUCTIONAL MANUAL  
FOR THE US AIR FORCE  
NEW HARVEST EAGLE FIELD  
FEEDING SYSTEM**

**BY EUGENE M. NUSS  
GEORGE TURK  
AND  
PHILIP BRANDLER**

**JULY 1982**

**UNITED STATES ARMY NATICK  
RESEARCH & DEVELOPMENT LABORATORIES  
NATICK, MASSACHUSETTS 01760**



**APPROVED FOR PUBLIC RELEASE; DISTRIBUTION UNLIMITED.**

**OPERATIONS RESEARCH AND SYSTEMS ANALYSIS OFFICE**

Approved for public release; distribution unlimited.

Citation of trade names in this report does not constitute an official indorsement or approval of the use of such items.

Destroy this report when no longer needed. Do not return it to the originator.

UNCLASSIFIED

SECURITY CLASSIFICATION OF THIS PAGE (When Data Entered)

REPORT DOCUMENTATION PAGE		READ INSTRUCTIONS BEFORE COMPLETING FORM
1. REPORT NUMBER NATICK/TR-82/034	2. GOVT ACCESSION NO.	3. RECIPIENT'S CATALOG NUMBER
4. TITLE (and Subtitle) AN INSTRUCTIONAL MANUAL FOR THE US AIR FORCE NEW HARVEST EAGLE FIELD FEEDING SYSTEM		5. TYPE OF REPORT & PERIOD COVERED
7. AUTHOR(s) Dr. Eugene M. Nuss Mr. George Turk Mr. Philip Brandler		6. PERFORMING ORG. REPORT NUMBER NATICK/TR-82/034
9. PERFORMING ORGANIZATION NAME AND ADDRESS Operations Research & Systems Analysis Office (DRDNA-O) US Army Natick Research & Development Laboratories Natick, Massachusetts 01760		8. CONTRACT OR GRANT NUMBER(s)
11. CONTROLLING OFFICE NAME AND ADDRESS		10. PROGRAM ELEMENT, PROJECT, TASK AREA & WORK UNIT NUMBERS 6.27.24A, 1L162724-AH99, Task AA, Work Units 036, 050, 051, 061, 066
14. MONITORING AGENCY NAME & ADDRESS (if different from Controlling Office)		12. REPORT DATE July 1982
		13. NUMBER OF PAGES 272
		15. SECURITY CLASS. (of this report) UNCLASSIFIED
16. DISTRIBUTION STATEMENT (of this Report)  Approved for public release: distribution unlimited.		15a. DECLASSIFICATION/DOWNGRADING SCHEDULE
17. DISTRIBUTION STATEMENT (of the abstract entered in Block 20, if different from Report)		
18. SUPPLEMENTARY NOTES  Service Requirement Identification: JSR AMAF 81-20 (III) (Formerly MSR USAF 9-1)		
19. KEY WORDS (Continue on reverse side if necessary and identify by block number) FIELD FEEDING SYSTEM    FOOD SERVICE SYSTEM    MANAGEMENT TRAINING AIR FORCE    FIELD EQUIPMENT    NEW HARVEST EAGLE PORTABLE EQUIPMENT    GUIDELINES    INSTRUCTION MANUAL HEATERS (WATER)    TRAINING		
20. ABSTRACT (Continue on reverse side if necessary and identify by block number)  This report is an instructional manual describing the shelter system and equipments which constitute the New Harvest Eagle Field Feeding System. It also details and illustrates procedures for erecting, assembling, and operating the system. An On-The-Job Training Program for Food Service Workers is included as is a set of general guidelines for food service managers. This manual describes the end product of a three-year empirical study of US Air Force Field Feeding Requirements. The New Harvest Eagle as described herein was successfully field-tested at Eglin AFB, June to September 1980, and at a Korean Exercise, February to March 1981. The Air		

UNCLASSIFIED

SECURITY CLASSIFICATION OF THIS PAGE(When Data Entered)

20. ABSTRACT (cont'd)

Force has initiated procurement actions to procure the system for the Rapid Deployment Force and Bare Base Feeding.

UNCLASSIFIED

SECURITY CLASSIFICATION OF THIS PAGE(When Data Entered)

## PREFACE

The authors acknowledge with gratitude the substantial contributions to this report made by US Air Force personnel, US Army Natick Research and Development Laboratories technicians, and civilian consultants. The list of individual contributors is too long to include here; however, key personnel and their respective organizations are recognized as follows:

Dr. Robert J. Byrne, Chief, Operations Research and Systems Analysis Office.

Mr. Roger Merwin and staff of the Air Force Engineering and Services Center, Tyndall AFB, FL.

Mr. Jeremy Wailes (consultant) of Arthur D. Little, Inc., Cambridge, MA.

Mr. Thaddeus Bonczyk (consultant) of Westboro, MA.

Mr. Ernest Saab and associates of the Aero-Mechanical Engineering Laboratory (NLABS).

Mr. John Perry and associates of the Food Engineering Laboratory (NLABS).

Mr. Joseph Wall of the Operations Research and Systems Analysis Office (NLABS).

Mr. Fred Meers and co-workers of the Audio Visual Division (NLABS).

Mr. Joseph Abreu and co-workers of the Reproduction Branch (NLABS).

Ms. Phyllis Bernstein (editorial consultant) of the Operations Research & Systems Analysis Office (NLABS).



**US AIR FORCE**  
**NEW HARVEST EAGLE**  
**FIELD FEEDING COMPLEX**

## TABLE OF CONTENTS

	Page	
LIST OF FIGURES	7	
LIST OF TABLES	13	
INTRODUCTION	15	
SECTION I	NEW HARVEST EAGLE (NHE) SHELTER COMPLEX	17
	Overview	18
	Training Objectives	19
	Special Considerations	20
	Equipment and Space Requirements	20
	A. Terminology	21
	B. Selection of Site and Layout Plan	27
	C. Assembly of Shelter Frame	35
	D. Installation of Coverings	45
	E. Erecting Shelter and Vestibule	61
	F. Installation of Lighting Bars in Kitchen, Dining, and Sanitation/Storage/Vegetable Prep Shelters	74
	G. Liner Installation	74
SECTION II	NHE EQUIPMENT LAYOUT PLAN	79
	Overview	80
	Training Objectives	80
	Equipment Layout Plans	80
SECTION III	OPERATION OF WATER HEATER—M80 AND WATER PUMP UNITS	83
	Overview	84
	Training Objectives	84
	Special Considerations	85
	Equipment and Space Requirements	85
	A. Locating Portable Water Heater and Water Pump	86
	B. Setting Up Water Pump	87
	C. Setting Up Water Heater	89
	D. Start-Up Procedures	96

## TABLE OF CONTENTS (cont'd)

		Page
SECTION III	OPERATION OF WATER HEATER--M80 AND WATER PUMP UNITS (cont'd)	
	E. Shutdown Procedures	103
	F. Restart Procedures to Remedy Automatic Shutdown of Heater	104
	G. Maintenance Procedures	106
	H. Trouble-Shooting Procedures	110
SECTION IV	GREASE TRAP	115
	Overview	116
	Training Objectives	116
	Special Considerations	116
	Equipment and Space Requirements	117
	A. Locating the Grease Trap	118
	B. Grease Trap Assembly	119
	C. Installation	125
	D. Operation	128
	E. Trouble-Shooting Procedures	128
SECTION V	REMOTE TANK BURNER SYSTEM	129
	Overview	130
	Training Objectives	130
	Special Considerations	130
	System Components	130
	A. Setting Up Fuel Tanks and Air Tanks	132
	B. Lighting the Gasoline Torch	136
	C. Installing the Burner Unit	138
	D. Opening the Safety Valve	139
	E. Lighting the Preheater	140
	F. Lighting the Burner Head	142
	G. Extinguishing and Removing the Burner Unit	144
	H. Shutdown of Burner System at End of Day	145
	I. Start Up of Burner System at Beginning of Day	145

## TABLE OF CONTENTS (cont'd)

		Page
SECTION VI	SHELTER LIGHTING	147
	Overview	148
	Training Objectives	148
	Special Considerations	148
	Equipment Requirements	148
	A. Lighting Assembly	149
	B. Installation	150
SECTION VII	PORTABLE SHELTER HEATER 400,000 BTU	155
	Overview	156
	Training Objectives	156
	Special Considerations	157
	A. Assembly	157
	B. Operation	161
	C. Shutdown Procedures	163
SECTION VIII	STEAMTABLE AND GRIDDLE ASSEMBLIES	165
	Overview	166
	Training Objectives	166
	Assembly	167
SECTION IX	THREE SINK ASSEMBLY	175
	Overview	176
	Training Objectives	176
	Assembly	177
SECTION X	TRAY PACK	183
	Overview	184
	Training Objectives	184
	A. Packing/Shipping/Storage/Instructions	184
	B. Instructions for Heating	185
	C. Instructions for Opening	187

## TABLE OF CONTENTS (cont'd)

		Page
SECTION XI	OTHER FOOD SERVICE EQUIPMENT AND SUPPLIES	189
	A. Dining Shelter	190
	B. Kitchen Shelter	192
	C. Sanitation and Storage Shelter	194
SECTION XII	MANUFACTURERS' OPERATION AND MAINTENANCE INSTRUCTIONS	195
	Overview	196
	A. Bunn-O-Matic Coffee Brewers	197
	B. Deep-Fat Fryer	199
	C. Ventilator for Deep-Fat Fryer	204
	D. Grease Filter for Deep-Fat Fryer	206
	E. Automatic Potato Extruder	208
	F. Hand Operated Potato Extruder	224
	G. Tilt Fry/Braising Pan	227
	H. Insulated Hot Food Cabinet	230
	I. Refrigerator, Upright, Reach-In	233
SECTION XIII	NEW HARVEST EAGLE FIELD FEEDING SYSTEM ON-THE-JOB TRAINING GUIDE	251
	Purpose	252
	Background	252
	Procedures	252
	Coordination and Control	253
	Checkout Forms	253
	Equipment	255
SECTION XIV	GUIDELINES FOR FOOD SERVICE MANAGERS	271

## LIST OF FIGURES

	Page
Figure 1. A Standard and a Doorway Purlin	21
Figure 2. Vestibule Arch and Frame Legs	22
Figure 3. Arch and Header	22
Figure 4. Roof Blanket (Window Section)	23
Figure 5. Roof Blanket (Door Section)	23
Figure 6. Fly – 8'	24
Figure 7. End Curtain	24
Figure 8. Vestibule Blanket	25
Figure 9. Vestibule End Curtain	25
Figure 10. Ridge and Eave Extenders	26
Figure 11. A Peg and Three Stakes	26
Figure 12. Shelter Area Layout Plan (Diagram 1)	28
Figure 13. Shelter Area Layout Plan (Diagram 2)	30
Figure 14. Shelter Area Layout Plan (Diagram 3)	31
Figure 15. Shelter Area Layout Plan (Diagram 4)	32
Figure 16. Shelter Area Layout Plan (Diagram 5)	33
Figure 17. Shelter Area Layout Plan (Diagram 6)	36
Figure 18. Shelter Modules Plan	37
Figure 18A. Dining Area Layout (220 Capacity)	38
Figure 19. Worker Securing Pin in Shelter Arch	39
Figure 20. Worker Securing Shelter Header	40
Figure 21. Standard Purlin Installed at Ridge	41

## LIST OF FIGURES (cont'd)

	Page
Figure 22. Workers Assembling Frame Arch	42
Figure 23. Assembled Shelter Frame Parts	43
Figure 24. Purlin Brace Handle Properly Locked	44
Figure 25. End Curtain Installation	46
Figure 26. Roof Blanket Draped Across Frame	47
Figure 27. Beginning the Becket Sequence at Arch Ridge	48
Figure 28. Attaching the End Curtain to the Roof Blanket	49
Figure 29. Passing Second Loop Through First Loop	50
Figure 30. Drawing First Loop Taut by Pulling Second Loop Down	51
Figure 31. Finishing the Becket Sequence at the Eave Hinge	52
Figure 32. The Reverse Becket Procedure	53
Figure 33. Finishing the Becket Sequence	53
Figure 34. Becket Sequence Half-Way to Eave Hinge	54
Figure 35. Ridge and Eave Extenders and Securing Clips	55
Figure 36. Installed Ridge Extender	56
Figure 37. Installed Eave Extender	57
Figure 38. Fly Drawn Across Frame Assembly on Top of Roof Blanket	58
Figure 39. Fly Attached to Eave Extender	59
Figure 40. Guylines Passed Through Canvas Loops	60
Figure 41. Guylines After Pulled Around Top Post Extension	61
Figure 42. The Correct and Incorrect Positions for Raising Shelter	62
Figure 43. Proper Position of Hand for Shelter Raising	63

## LIST OF FIGURES (cont'd)

	Page
Figure 44. Securing Arch Leg in Open Position at Eave	64
Figure 45. Attaching Guylines to Stakes	65
Figure 46. Securing Purlin Coverings	66
Figure 47. Steel Corner Stakes Inserted into Base of the Arch Frame Legs	67
Figure 48. Tent Guylines in Place	68
Figure 49. Becketing Vestibule Cover to Transition Piece	69
Figure 50. Vestibule Blanket—Securing Pins	70
Figure 51. Fully Installed Vestibule	71
Figure 52. Securing Vestibule End (Free Standing)	72
Figure 53. Vestibule End Curtain	73
Figure 54. End-Wall Liner With Ceiling Installed	75
Figure 55. Liner Being Secured to Header	76
Figure 56. Cotton Ties Secured Around Shelter Frame	77
Figure 57. Velcro Seam for Joining Liners Together	78
Figure 58. New Harvest Eagle Equipment Layout	81
Figure 59. Placement of the Water Heater, Water Pump, and Fuel Drum	86
Figure 60. Major Parts of Water Pump	87
Figure 61. Electrical Plug Connected to Pump	88
Figure 62. Water Heater in Preoperational Mode	89
Figure 63. Hot Water Hose Attached to Heater	90
Figure 64. T—Fitting for Storing Fuel Lines	91
Figure 65. Fuel Lines Connected to Heater	92

## LIST OF FIGURES (cont'd)

	Page
Figure 66. Fuel Fill-Vent Assembly Prior to Installation	93
Figure 67. Fuel Fill-Vent Assembly Installed	94
Figure 68. Electrical Lead Plugged into Heater	95
Figure 69. Water Pump Switch and Motor Casing	96
Figure 70. Water Lever Valves in OPEN Position	97
Figure 71. Water Lever Valve in CLOSED Position	98
Figure 72. Water Heater Switch in OFF Position	100
Figure 73. Heater Showing Sight Tubes	101
Figure 74. Heater Operating Control Dial	102
Figure 75. Water Heater Temperature Indicator and Operating Control	103
Figure 76. Major Parts Relative to Shutdown of Heater	104
Figure 77. Water Pump	106
Figure 78. Grease Trap Packaged Prior to Assembly	118
Figure 79. Unassembled Grease Trap	119
Figure 80. Preparing Grease Trap for Assembly	120
Figure 81. Workers Assembling Sump Pump Panels	121
Figure 82. Proper Positioning of Side and Sump Pump Panels	122
Figure 83. Assembled End Panels	123
Figure 84. Correct Placement of Baffles	124
Figure 85. Installation of Discharge Pipe, Float Switch, Sump Pump, and Control Box	125
Figure 86. Drain and Discharge Hoses	126
Figure 87. Submersible Heater Installed	127

## LIST OF FIGURES (cont'd)

	Page
Figure 88. Fuel Line Layout	132
Figure 89. Main Fuel Tank	133
Figure 90. Sandbags Positioned to Protect Fuel Tanks	134
Figure 91. Fuel Service Line Connected to Fuel Quick Disconnect Fitting	135
Figure 92. Gasoline Torch	136
Figure 93. The Burner Unit	138
Figure 94. The Safety Valve in Open Position	139
Figure 95. Burner Unit Showing Preheater Components	140
Figure 96. The Burner Unit Showing Generator and Burner Head	142
Figure 97. Burner Unit Showing Disconnect Safety Valve	144
Figure 98. Bruce Lighting Assembly	149
Figure 99. Installed Lighting Bar and Support Strap	150
Figure 100. Lighting Support Strap Pulled Through Kitchen Liner	151
Figure 101. Lighting Tube Installation	152
Figure 102. Installed Lighting Tube	153
Figure 103. Lighting Tube Connected to Electrical Lead	154
Figure 104. Heater in Position Near Shelter	157
Figure 105. Air Heater Showing Air Intake and Exhaust Components	158
Figure 106. Air Duct Connected to Dining Shelter	159
Figure 107. Air Duct Adapter Fitted to the Open End of the 12" Air Duct	160

## LIST OF FIGURES (cont'd)

	Page
Figure 108. Controls and Gauge for the Air Heater	161
Figure 109. Gasoline Engine Showing Essential Start-Up Parts	162
Figure 110. Unassembled Griddle Assembly	167
Figure 111. Unassembled Steamtable Assembly	167
Figure 112. The Burner System Exhaust Stack Assembly	168
Figure 113. Assembled Lower Frame	169
Figure 114. Frames With Exhaust Housing Installed	170
Figure 115. Upper Frames Assembled	170
Figure 116. Flame Guards Installed on Griddle and Steamtable	171
Figure 117. Grease Chute	172
Figure 118. Correct Positioning of the Grease Chute	173
Figure 119. Fully Assembled Steamtable and Griddle	174
Figure 120. Complete Three Sink Assembly	176
Figure 121. Sink Components	177
Figure 122. Burner Rack in Place	178
Figure 123. Sink Body in Place	179
Figure 124. Sink Adapter and Sink Faucet Fixture	180
Figure 125. Sinks Joined Together	181
Figure 126. Tray Pack and Lifter	186
Figure 127. Tray Pack Positioned for Opening	187
Figure 128. Tray Packs in Steamtable on Serving Line	188

## LIST OF TABLES

	Page
Table 1. NHE Components Matrix	34
Table 2. List of Equipment by Functions	82
Table 3. Maintenance Procedures for the Water Heater	108
Table 4. Trouble-Shooting Procedures for the Water Heater	110
Table 5. Trouble-Shooting Procedures for the Grease Trap Assembly	128
Table 6. Food Service Equipment and Supplies for Dining Shelter	190
Table 7. Food Service Equipment and Supplies for Kitchen Shelter	192
Table 8. Food Service Equipment and Supplies for Sanitation and Storage Shelter	194



# AN INSTRUCTIONAL MANUAL FOR THE US AIR FORCE NEW HARVEST EAGLE FIELD FEEDING SYSTEM

## INTRODUCTION

This work was performed under DA Project 1L162724 AH99, Tech Effort AA—Analysis and Design of Military Feeding Systems. Mr. Philip Brandler was the military service requirement manager during the effort and Dr. Eugene M. Nuss was the principal investigator.

This technical report is primarily an instructional manual assembled for use by food service and engineer personnel who will erect, assemble, operate, and maintain the New Harvest Eagle food service system. The manual is also designed to be used as a training aid by instructors who will prepare others to operate the system. An approach to on-the-job training is described in the manual, and a final section offers food service managers guidelines to successful management of the New Harvest Eagle.

Subsystems of the New Harvest Eagle are described and illustrated throughout the manual, and operational procedures for each component are detailed. Manufacturers' operation and maintenance instructions are provided for each commercial equipment item. A videotape showing the erection of the shelter system and equipment placement was produced and is recommended for viewing in conjunction with the use of the instructional manual.

The New Harvest Eagle system as described herein is the system as it was field tested at the Korean exercise Team Spirit '81. It is probable some modifications to the system will be made after this report is published and prior to the time the system is fielded by the Air Force. Users of this manual will want to check with the Air Force Engineering and Services Center, Tyndall AFB, FL (AFESC), for such changes in the system and for the appropriate updating of this document and for videotape availability.



**SECTION I**

**NEW HARVEST EAGLE (NHE) SHELTER COMPLEX**

## OVERVIEW

The NHE shelter complex is comprised of three (3) shelters with connecting vestibules. Although this manual describes procedures for assembly and erection of the kitchen shelter, these are standard procedures which apply to the sanitation and storage shelter as well as the dining shelter. One supervisor and a team of four (4) people can efficiently assemble and erect the kitchen shelter, the sanitation and storage shelter and the dining shelter. This training manual provides instructions and procedural steps to:

- select and prepare site for shelter complex;
- survey and layout a floor plan for each shelter;
- assemble shelter frame;
- install shelter coverings;
- erect shelter.

It is recommended that the entire NHE shelter complex be erected in this sequence: (1) kitchen shelter; (2) sanitation and storage shelter; (3) dining shelter, and (4) connecting vestibule walkways.

The NHE Shelter Complex Area Layout Plan is included to be a guide for surveying the overall shelter site. The exact location of the shelters, doorways, and vestibules may differ somewhat at the discretion of the supervisor whenever the terrain or circumstances of the location demand such modifications.

Once the NHE kitchen shelter is erected there is one distinct feature about equipping the kitchen shelter which is not found in the adjoining shelters. A white liner is provided for the kitchen shelter and should be installed after the kitchen shelter has been raised into position and the vinyl flooring has been laid down. In conditions of high winds, wet or soggy ground and rain storms, it is recommended that the supervisor follow the procedures outlined in the manual in order to keep the liner clean and dry. However, at his discretion, the liner may also be suspended from the center purlin (along the ridge) prior to installation of the roof blanket and erection of the kitchen shelter. This option can save time working overhead to tie liner into place and the use of a ladder.

All of the assembly operations described in this section can be accomplished swiftly and reliably when two people work as a pair on each task. An optimal working team is considered to be two pairs plus one supervisor to oversee assembly operations. It is recommended, however, when an assembled shelter is to be raised that there should be **one person on each frame leg** to lift and position shelter properly.

This section of the manual describes layout, assembly, and erection procedures for the maximum capacity of the NHE shelter complex; that is, kitchen shelter, five units; sanitation and storage shelter, eight units; and dining shelter, 11 units. The overall design of the shelter complex is modular so that the actual number of units in each shelter will vary to meet the

requirements of the deployment and the particular mission contingencies. The minimum manpower required to assemble and erect the shelter complex is three, if the shelters are constructed on a module basis and then joined together. This flexibility in the NHE shelter complex accommodates extreme circumstances of manpower shortages and allows for substantial self-sufficiency by the Air Force food service staff.

## TRAINING OBJECTIVES

The trainee must be able to demonstrate a capability to plan and layout a site for the shelter complex, assemble, and erect the shelter with its connecting vestibules.

### Siting (Supervisor Only)

1. Select a site suitable for the assembly and erection of NHE shelter complex. (A suitable site is described in this manual is level and free of obstructions and a minimum dimension of 125 x 110 feet.)
2. Plan out and mark the corner points of the site's general area.
3. Plan out and mark the location of each shelter and the connecting vestibules.
4. Identify the "reference point" that lies along the base line of the first shelter.
5. Use the "reference point" to plan out and mark the precise location for the arches of the kitchen shelter (to be erected first).

### Erection

The trainee must be able to demonstrate a capability to work as a partner or as a team member to assemble and erect the shelter:

1. Identify individual components of the shelter frame, with special attention being given to doorway purlins.
2. Work as a pair to assemble the shelter frame — arches, headers, and purlins.
3. Work as a pair to cover frame with a roof blanket which matches the type of ground purlin used.
4. Distinguish between ridge extenders and eave extenders, and install them in an appropriate place on the frame.
5. Work as a pair to attach the fly.
6. Work as a team (one person per arch) to erect shelter—first raise one side and then the other side of the shelter.

7. Secure the shelter with guylines and ground pegs.
8. Install the lighting bar between the headers. After installation of the lighting bar, the kitchen liner should be installed.
9. Work as a pair to install the vinyl covered liner inside the kitchen shelter.

#### Vestibule

1. Identify individual components of the vestibule frame.
2. Work as a pair to assemble, cover and erect vestibule in position as a walkway between two adjoining shelters.

#### SPECIAL CONSIDERATIONS

- During shelter area layout, make certain that the three shelters are approximately parallel and that the doorways are aligned for clear passage between shelters.
- The arch hinges, at ridge and eave, can be damaged by rough handling or by dragging the frame across the ground. Arches should, therefore, be unfolded and handled with care and moved only when two people are available—one at each arch frame—and can lift together in order to reposition it.
- Procedures in this training manual describe the assembly and erection of the kitchen shelter. All components for the shelter complex are standard and therefore these same procedures may be followed to assemble and erect the sanitation and storage shelter and dining shelter.
- At the discretion of the supervisor, the lighting bars may be installed prior to kitchen shelter erection. However, they must be positioned between the headers of each module of the kitchen shelter after it is raised but before the liner is installed.

#### EQUIPMENT AND SPACE REQUIREMENTS

- NHE shelter components as indicated in the components matrix. Measuring tape (150'), string (1800'), ground pegs (24–60) and a wooden mallet.
- Level and open area a minimum of 125' x 110'.
- Shelter area equipped with (portable) water or selected to be within 20' of water source.
- Shelter area equipped with liquid and solid waste disposal or selected to permit appropriate drainage and interment of solid waste.

## A. TERMINOLOGY

Describing how to put up the NHE shelter necessarily means that we must refer to a lot of component parts that are unfamiliar to you. The easiest way to describe what we mean when we name a part is to show you a picture of that part. The next few pages are used for just that purpose . . . to show you pictures of the various component parts of the NHE shelter and to make you familiar with the terminology we will be using.

### 1. FRAME

Parts of the shelter frame are: purlin (both standard and doorway), vestibule frame legs and arch and header.

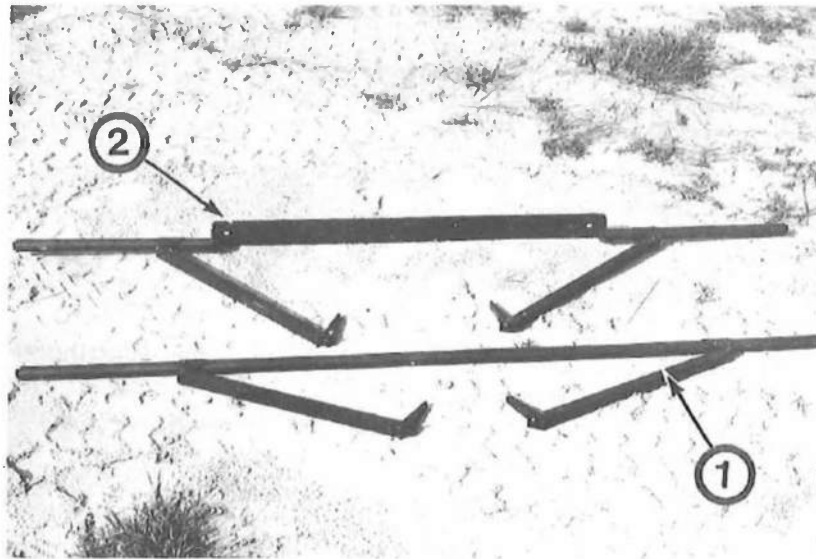

1. Standard Purlin

2. Doorway Purlin

Figure 1. A Standard and a Doorway Purlin

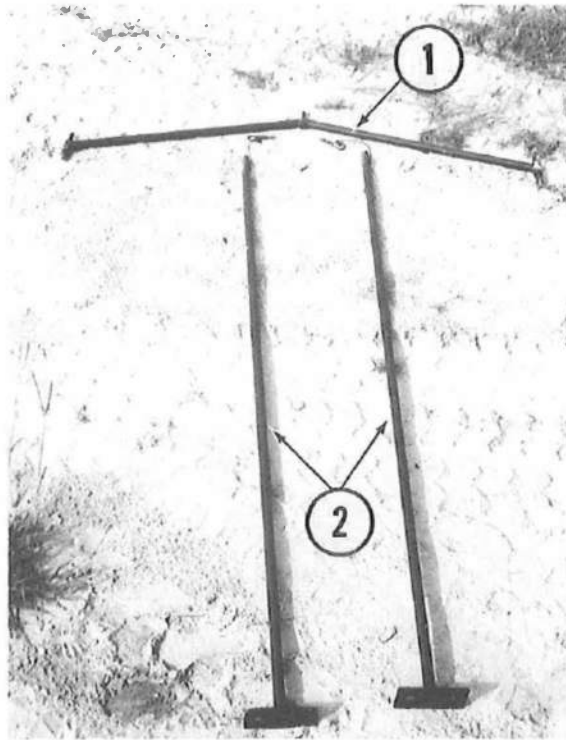

1. Arch (Vestibule)

2. Frame Legs (Vestibule)

**Figure 2. Vestibule Arch and Frame Legs**

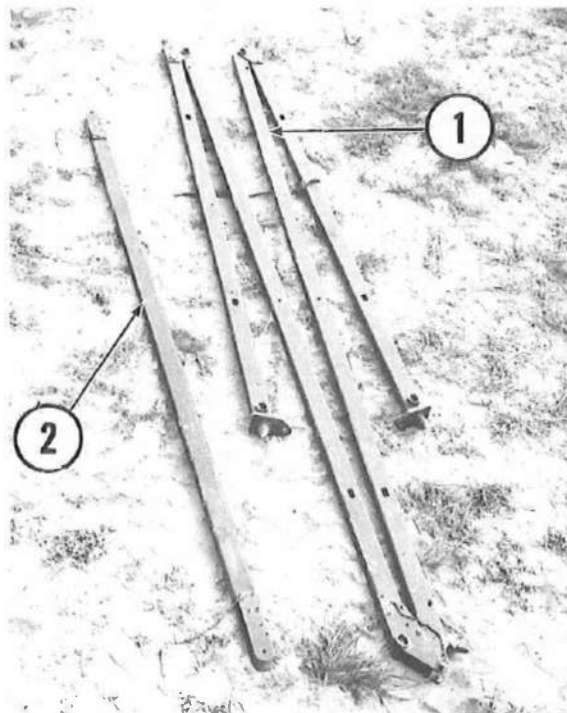

1. Arch

2. Header

**Figure 3. Arch and Header**

## 2. COVERINGS

Coverings for the shelter frame include: roof blanket (window sections and door sections), tent fly, end curtain, vestibule blanket, and vestibule end section.



Figure 4. Roof Blanket (Window Section)



Figure 5. Roof Blanket (Door Section)

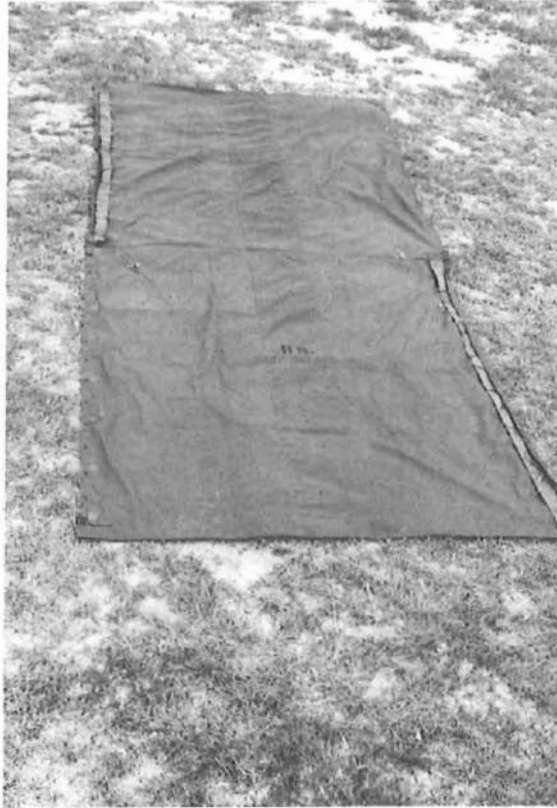

**Figure 6. Fly – 8'**

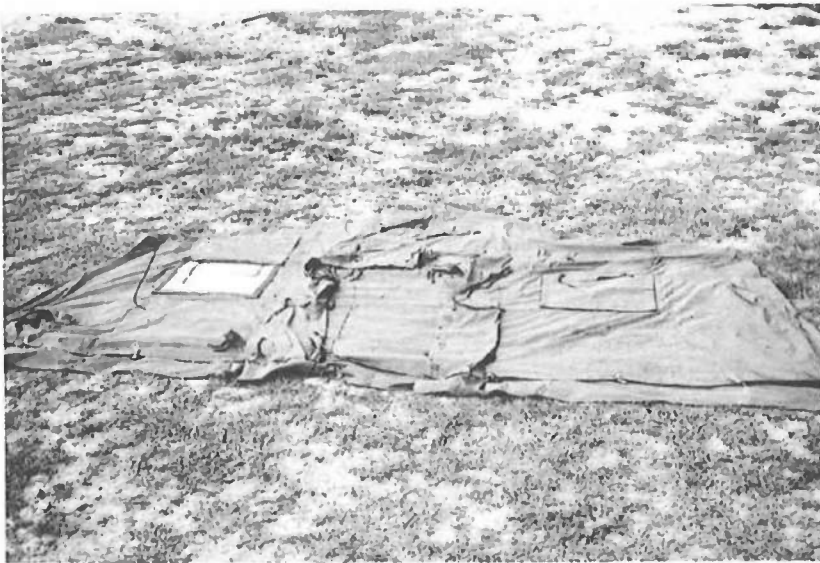

**Figure 7. End Curtain**



**Figure 8. Vestibule Blanket**



**Figure 9. Vestibule End Curtain**

### 3. COMPONENTS

Small component parts that are used to secure the shelter are: ridge extenders, eave extenders, aluminum ground stakes, steel corner stakes, wooden ground pegs, and wooden guyline stakes.

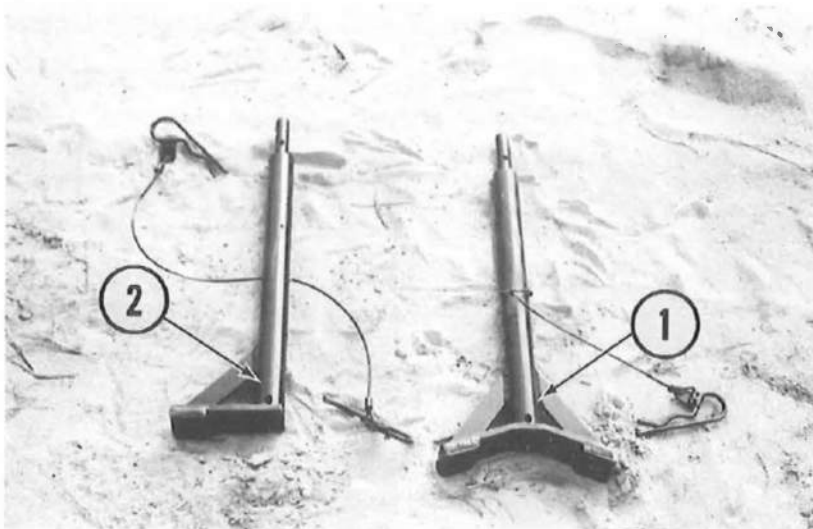

1. Ridge Extender

2. Eave Extender

Figure 10. Ridge and Eave Extenders

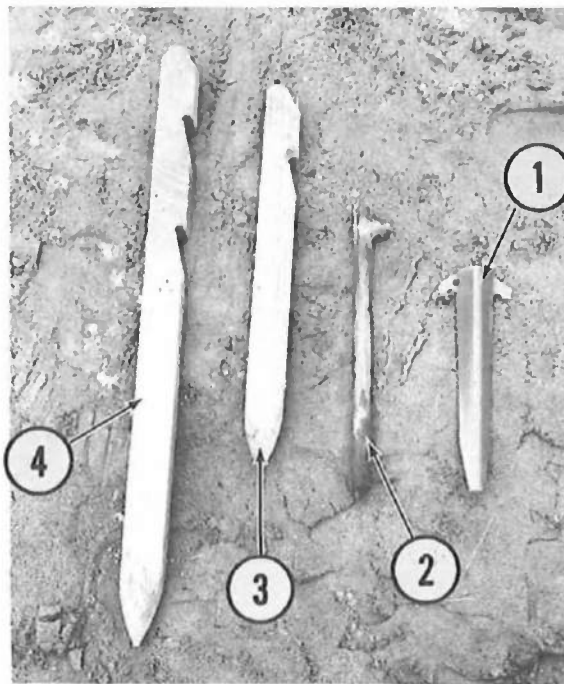

1. Aluminum Ground Stake

2. Steel Corner Stake

3. Wooden Ground Peg

4. Wooden Guyline Stake

Figure 11. A Peg and Three Stakes

## **B. SELECTION OF SITE AND LAYOUT PLAN**

### **1. SELECTING SITE FOR SHELTER COMPLEX**

The supervisor should observe the following rules for site selection:

- level ground, free of rocks, roots, underbrush and sharp objects;
- good drainage;
- near a water source but above any potential flood level;
- sheltered from high winds where feasible.

When laying out the shelter area, choose a location which is approximately 125 feet x 110 feet to allow some leeway during the surveying process. Take note that:

- entrances should not be directly downwind (as snow or sand accumulates on the lee side of a tent);
- sanitation and storage shelter should be positioned nearest to the water source;
- doorways and vestibules should be planned in order to allow clear passage among shelters;
- water heater, generator and fuel drum should be positioned downwind from the dining shelter.

### **2. SURVEY AND LAYOUT PLAN FOR SHELTER COMPLEX AREA**

To survey the general area for the shelter complex, first mark off the four corners with ground pegs to form a large rectangle 125 x 110 feet. (Be sure that the corners of the area are right angles. If you don't have a compass, use your watch. While standing at the second mark, sight along the watch from the 6 to the 12 to the first mark then, without changing the position of the watch, sight along it from the 9 to the 3, to the point at which the third corner mark should be placed. Repeat the procedure at the third mark in order to place the fourth mark.)

Remember that this general area should be relatively level and free from sharp obstructions.

Beginning at the lower right hand corner of the area (at the "START" on the Shelter Area Layout Plan—Diagram 1) measure along the 110-foot stretch to the upper righthand corner of the area and successively mark off these measurements:

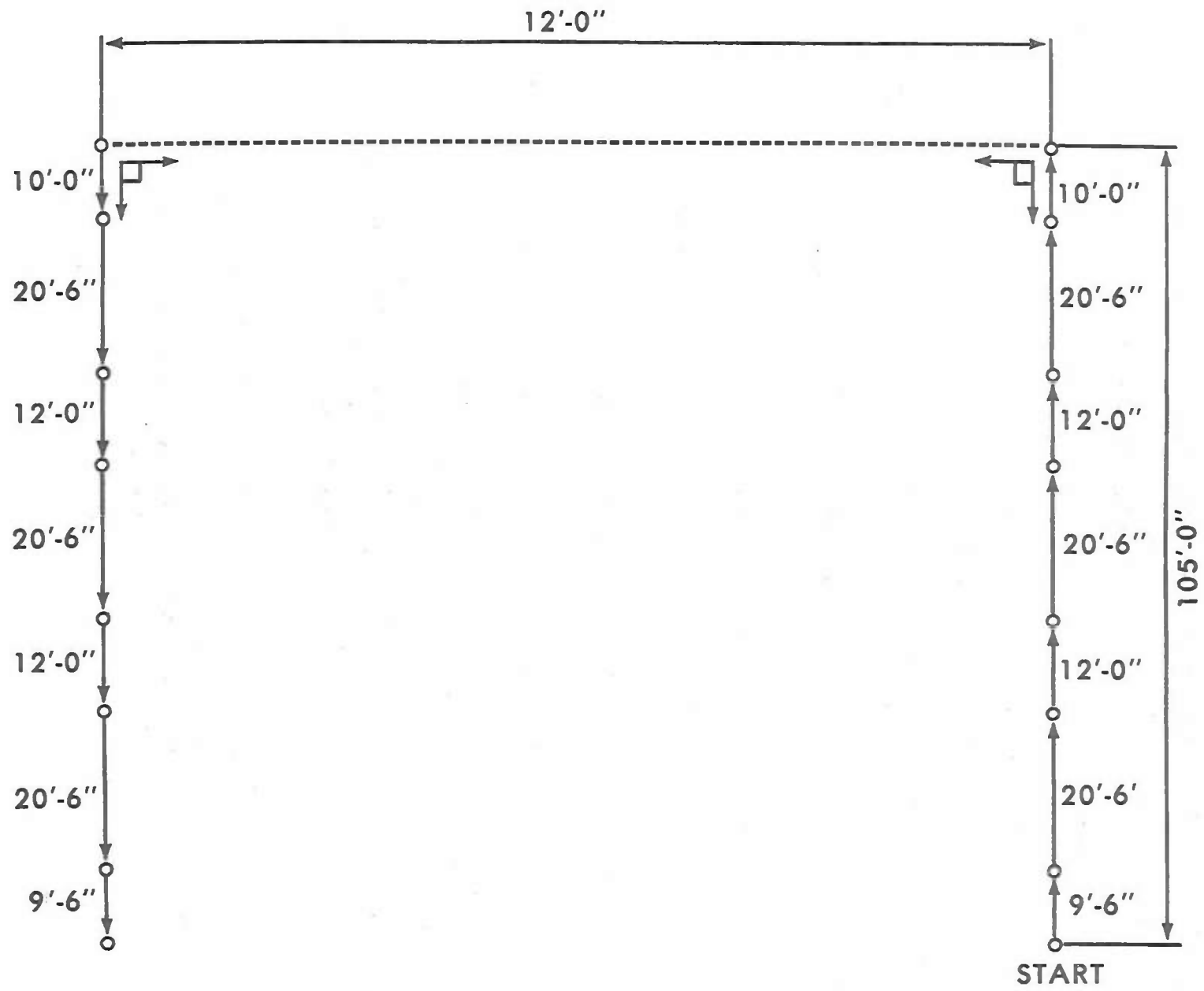

Figure 12. Shelter Area Layout Plan (Diagram 1)

Mark	Sum Distance
9'6"	9'6"
20'6"	30'
12'	42'
20'6"	62'6"
12'	74'6"
20'6"	95'
10'	105'

Next, mark off the same measurements along the 110-foot stretch on the opposite side of the area. Now connect these ground pegs with string that will reach from the right to the left side of the shelter area (as shown in Diagram 2).

Beginning again at the "START" point (see Diagram 3), measure along the 125-foot stretch to the lower lefthand corner of the area and mark off the following measurements:

Mark	Sum Distance
18'6"	18'6"
32'	50'6"
32'	82'6"
8'	90'6"
16'	106'6"
18'6"	125'

Next, repeat these measurements along the 125-foot stretch from the top lefthand corner to the top righthand corner of the area. Once again, use string to connect these ground pegs from the top to the bottom of the rectangular area. The overall site for the shelter complex should now resemble Diagram 4.

Identify the appropriate "Reference Points" (shown in Diagram 5) which define the boundaries for each of the three shelters, and mark them with a ground peg where the horizontal and vertical lines of string cross.

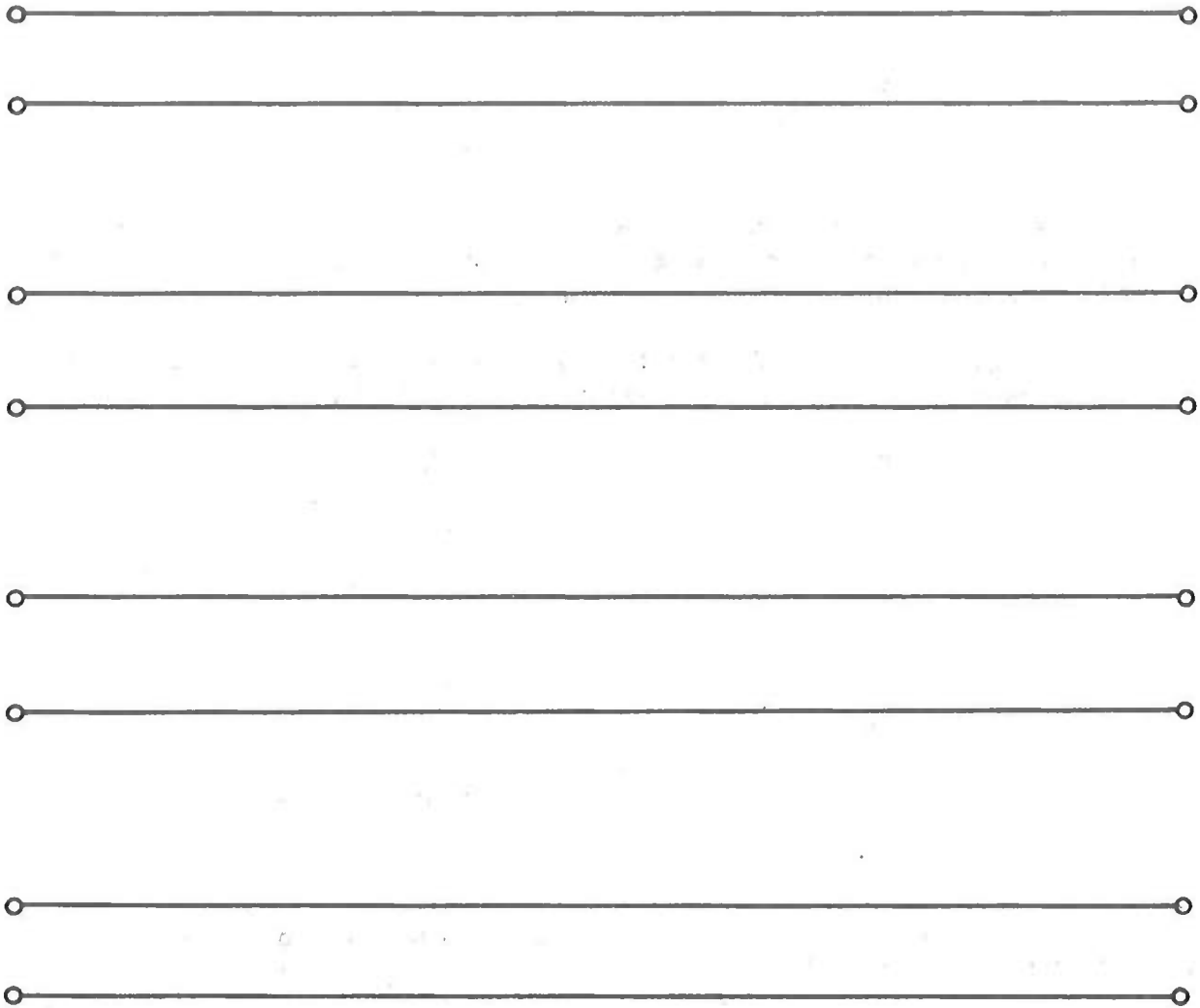

Figure 13. Shelter Area Layout Plan (Diagram 2)

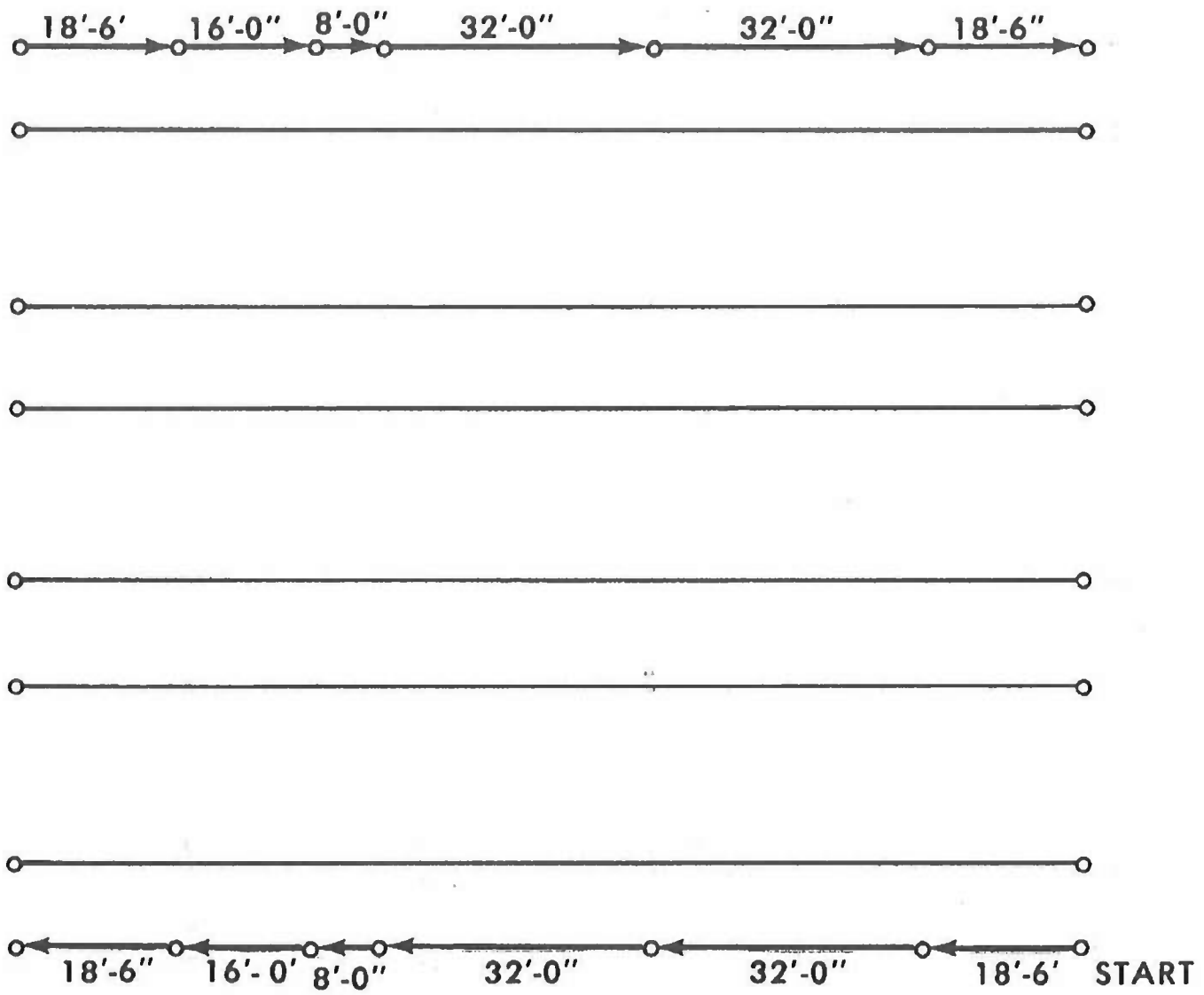

Figure 14. Shelter Area Layout Plan (Diagram 3)

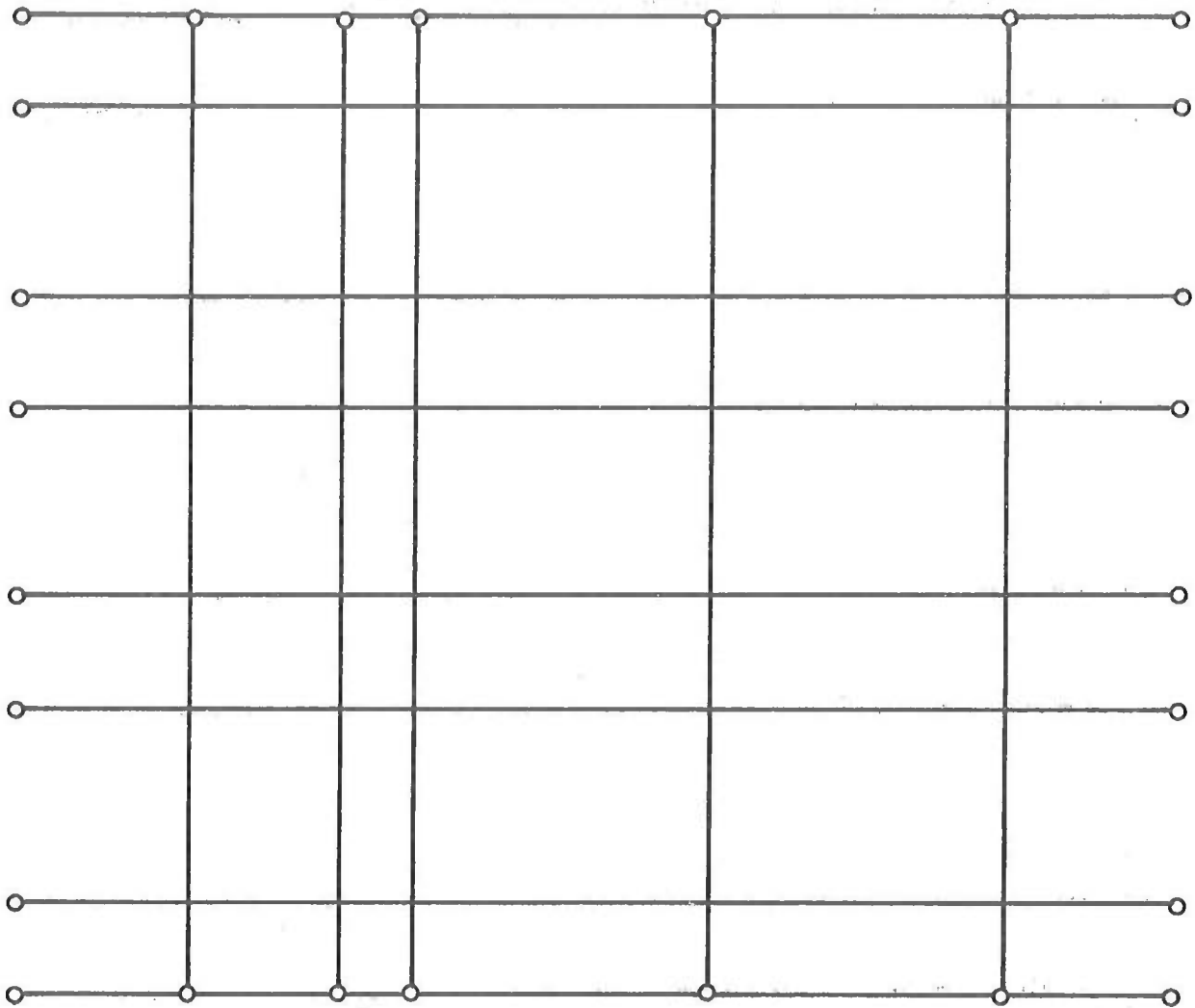

Figure 15. Shelter Area Layout Plan (Diagram 4)

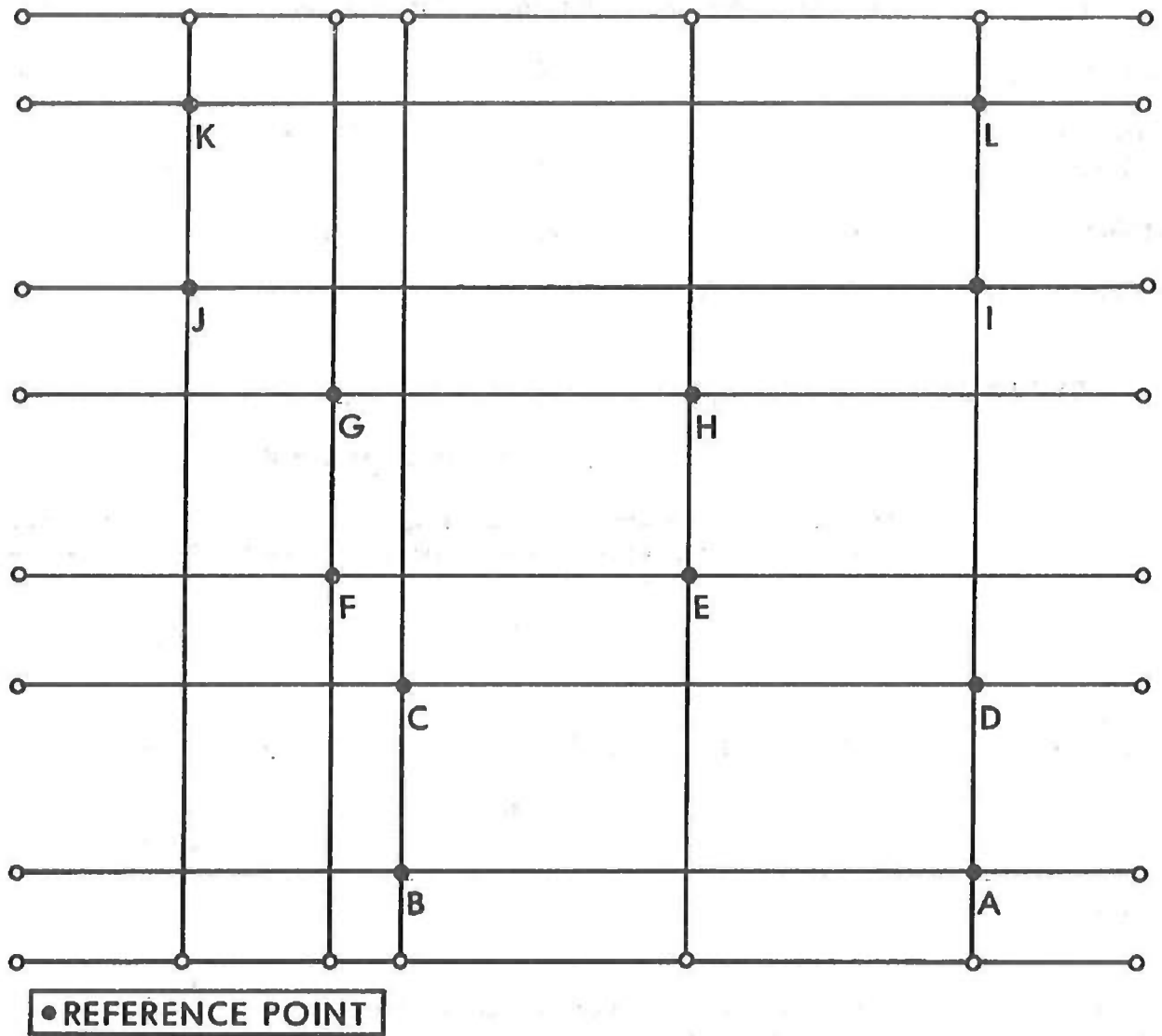

Figure 16. Shelter Area Layout Plan (Diagram 5)

**TABLE 1**  
**NHE COMPONENTS MATRIX**

**I. FRAME ASSEMBLY**

Shelter	No. of Modules	Components Required					
		Arches	Headers	Purlins Std. Doorway	Vestibule Arches	Vestibule Legs	
Kitchen	5	6	6	20	6	---	---
Sanitation and Storage	8	9	9	37	4	---	---
Dining	11	12	12	50	6	---	---
Vestibules	8	---	---	---	---	24	48

**II. COVERINGS**

Shelter	No. of Modules	Components Required						
		Extenders Ridge Eave		Blankets Window Doorway End			Fly	Vestibule Coverings
Kitchen	5	6	12	2	3	2	2@16' 1@8'	---
Sanitation and Storage	8	9	18	6	2	2	4@16'	---
Dining	11	12	24	8	3	2	5@16' 1@8'	---
Vestibules	8	---	---	---	---	---	---	8

Begin by erecting the kitchen shelter. Use Reference Point E (Figure 16) as the starting point for the layout and assembly of appropriate frame and covering components.

Reference Points A, B, C, D = sanitation and storage shelter

Reference Points E, F, G, H = kitchen shelter

Reference Points I, J, K, L = dining shelter

These twelve reference points identify the corner points for each shelter building and indicate their dimensions. The ground pegs all along the perimeter of the general area are no longer needed and may be pulled up. Also, the string may be put away so that no one will trip over it during the assembly and erection operations. The area should then resemble Diagram 6.

Use the Shelter Modules Plan (Figure 18) when laying out the component parts for each shelter, as it indicates the correct positioning of modules and connecting vestibules. Note that when the NHE shelter complex is fully assembled and erected, there should be clear passage between module 5 of the dining shelter, module 3 of the kitchen shelter and module 2 of the sanitation shelter; between dining module 6, kitchen module 4, and sanitation module 3; and between dining module 7 and kitchen module 5. Figure 18A identifies the enlarged dining area layout.

**NOTE:** Roof blankets are made in two designs: desert/tropical or temperate. Both designs come either as window sections or door sections. The desert/tropical roof blankets have screens in the roof and protecting canvas flaps. The use of these roof blankets in the kitchen shelter will provide maximum ventilation.

In preparing to erect each shelter, use the Shelter Modules Plan (Figure 18) as a guide to the number and type of packages of frame components and roof blankets that you will need. Lay out the appropriate packages close to the positions in which they will be used. The appropriate packages for each section within each shelter are indicated on the plan with either a "W" (for window section) or a "D" (for door section).

### **C. ASSEMBLY OF SHELTER FRAME**

#### **UNPACKING FRAMES**

1. Open the packages containing the shelter frames and remove the arch components. Carry the arches into position. Remember—the kitchen shelter will require six arches.
2. Remove the header components from the packages and carry them into position—one header beside each arch.

#### **ARCH AND HEADER ASSEMBLY**

3. Remove securing pins at the ridge and eave hinges of each arch before attempting to open the arch frame.
4. Undo the strap that holds the arch assembly together. Two people then unfold the arch to form an inverted "V", with the legs of the arch still folded up towards the ridge hinge.

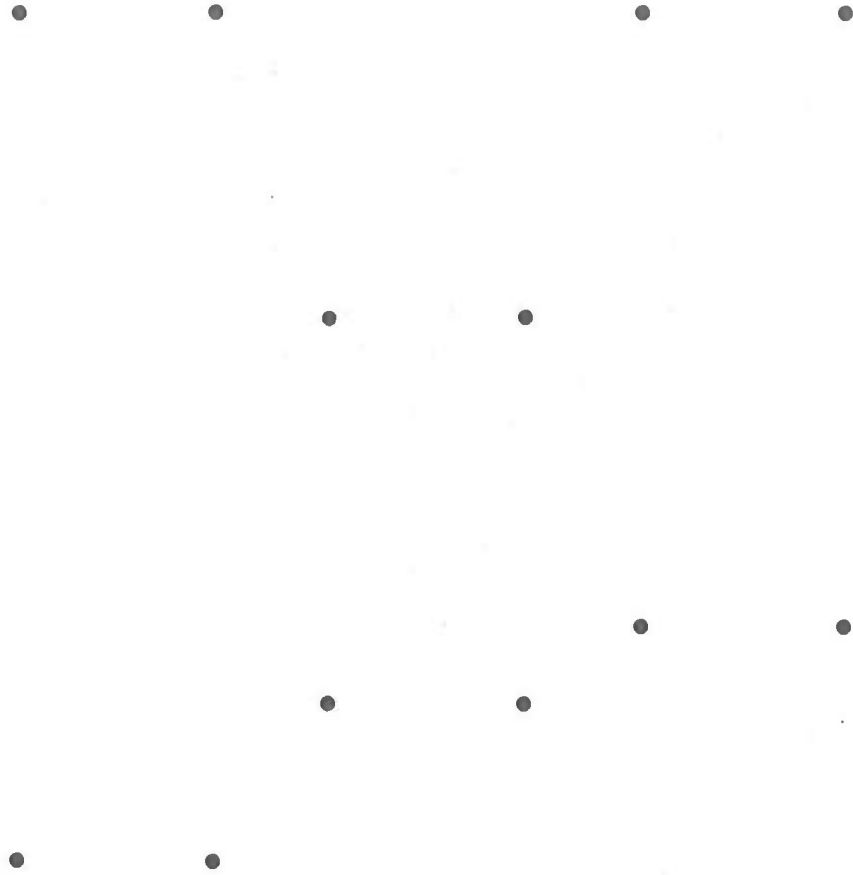

Figure 17. Shelter Area Layout Plan (Diagram 6)

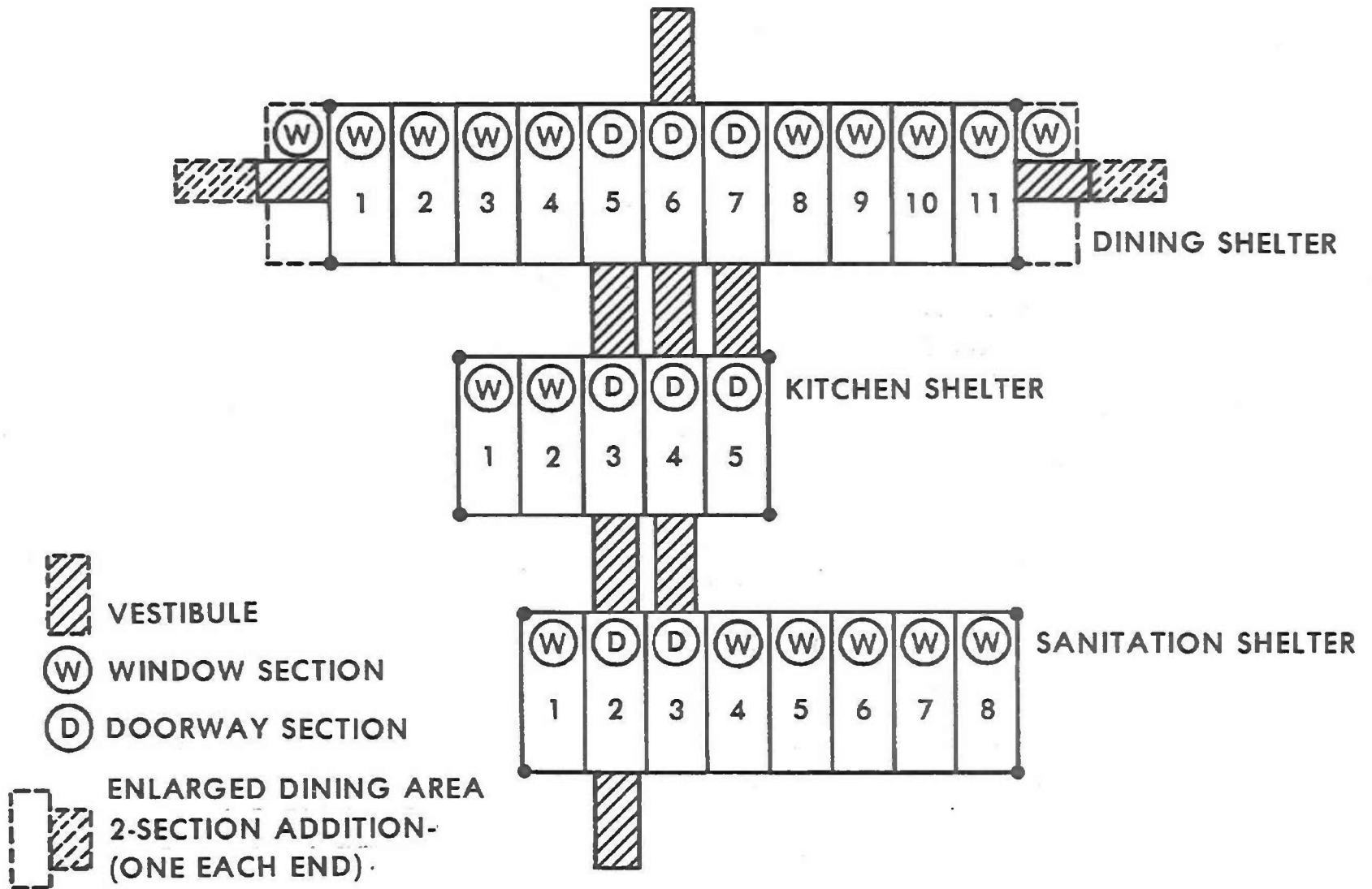

Figure 18. Shelter Modules Plan

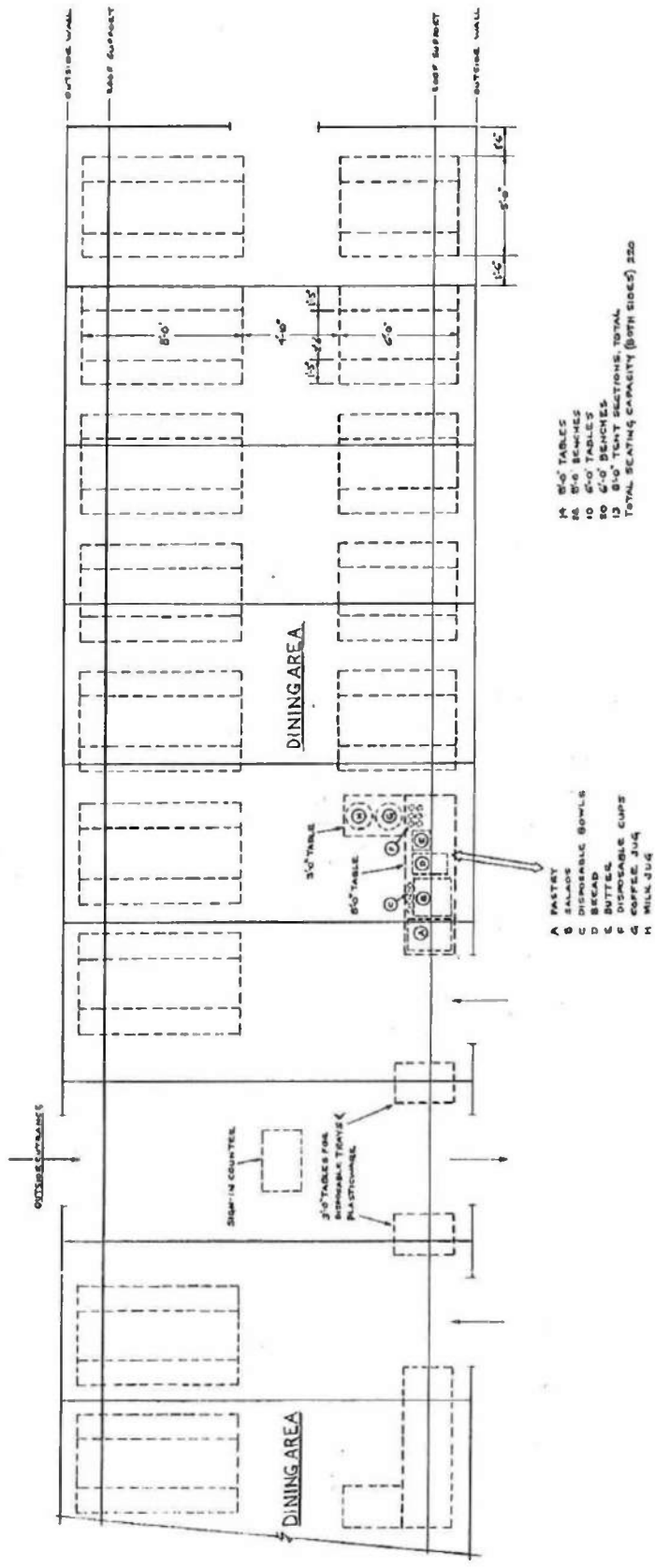
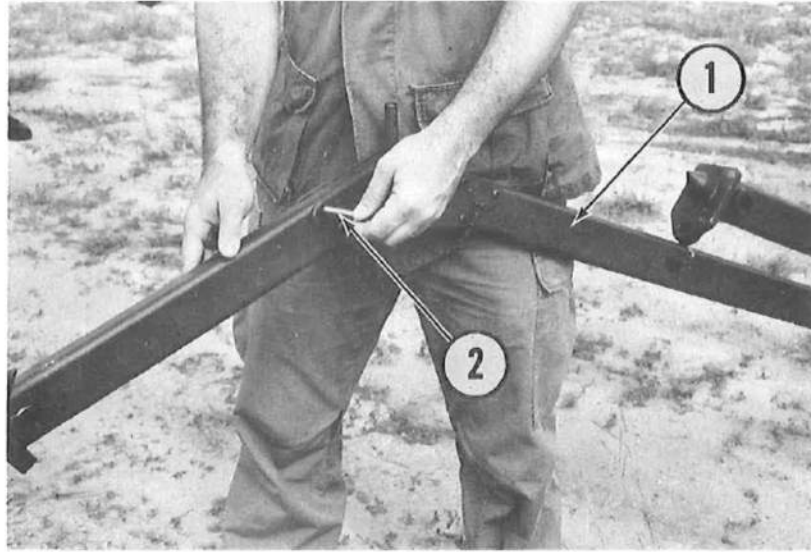

Figure 18A. Enlarged Dining Area Layout (220 Capacity)



1. Arch in Open Position      2. Securing Pin

**Figure 19. Worker Securing Pin in Shelter Arch**

5. While holding the arch frame near the ridge with one hand, align the holes at the ridge and push the securing pin (attached to the arch by a short chain) through the holes to lock the arch frame into an open position.

**CAUTION:** Whenever working at or near the frame hinges, be careful to avoid pinching your hands or fingers. Do not hold the hinge itself at the ridge or eave locations.

6. Unfold the arch legs. The frame should now be in this position:

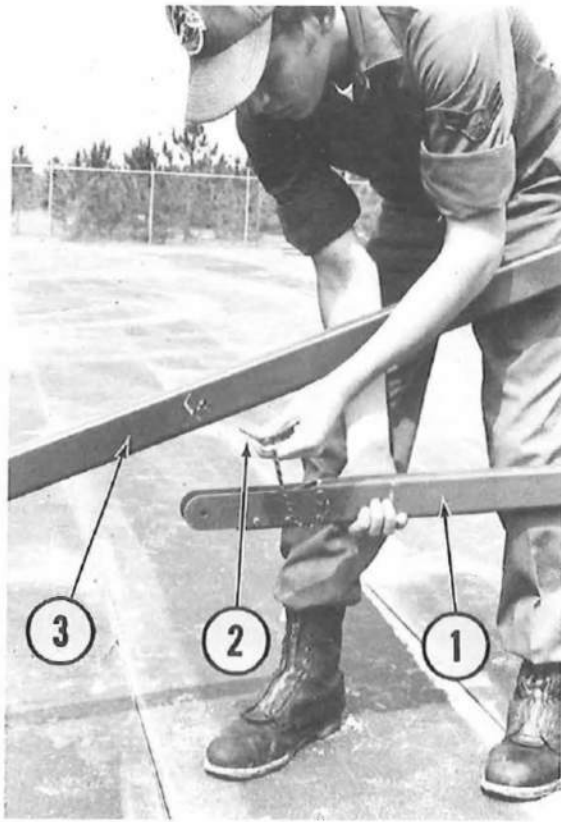

1. Header    2. Header Security Pin    3. Arch

**Figure 20. Worker Securing Shelter Header**

7. While one person steadies the upright arch assembly, the other should align the header up against the inside of the arch frame. Again, the person holding the arch assembly steady can also help with the alignment by gently holding the header 6" to 9" above the ground. Push securing pin through the header and into its hole in the arch frame to lock header into position. Next, the other end of the header is aligned and secured with the pin in a similar way to form the crosspiece of the arch.

8. When the headers have been locked into position on the first two arches, a standard purlin may be fitted into position at the ridge of each arch—forming a bridge between the two arches.



**Figure 21. Standard Purlin Installed at Ridge**

9. Install the standard purlin at the ridge so that the purlin is connected first to one arch assembly and then to the next arch. (Do not attempt to fit the purlin into position on both arches at the same time.) Two people take each end of the purlin and position themselves in between the two arch frames as shown in the picture above. Each holds an arch steady and, one at a time, they fit each purlin stud-end into its "keyhole" at the arch ridge.

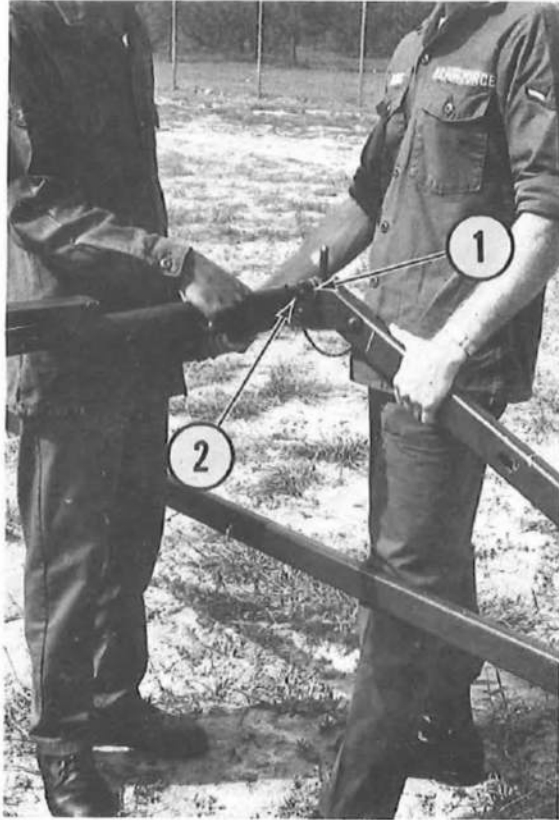

1. Keyhole at Arch Ridge

2. Purlin Stud

**Figure 22. Workers Assembling Frame Arch**

10. Apply light pressure with the outer hand on the arch frame and rotate the purlin 90° with the inside hand in order to lock the purlin stud securely into position. Again, be careful to keep your hand on the arch frame clear of the hinge to avoid pinching any fingers.

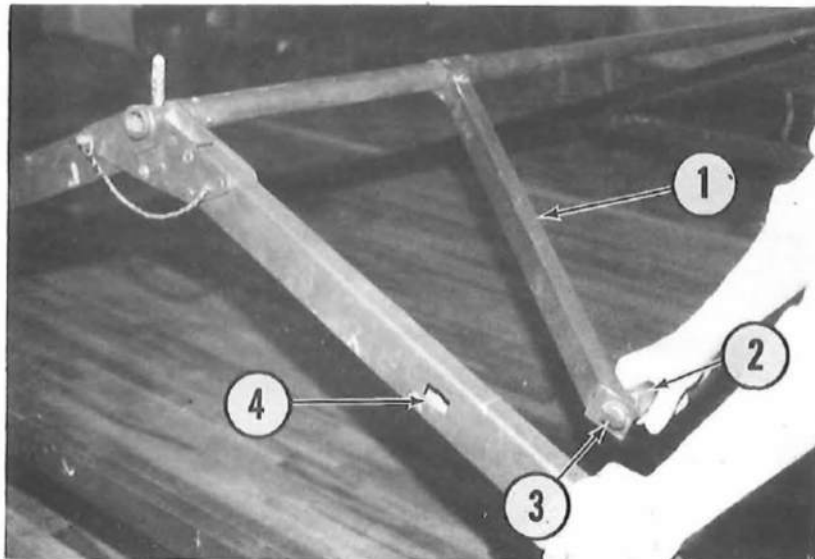

- 1. Purlin Brace Arm
- 2. Brace Handle

- 3. Brace Handle Stud
- 4. Keyhole in Arch

**Figure 23. Assembled Shelter Frame Parts**

11. Unfold the purlin braces. With one hand on the arch frame, (note that hand is below the hole for the purlin brace) guide the purlin brace arm (using the purlin brace handle) toward its "keyhole" in the arch frame. Insert purlin brace stud into its "keyhole" in arch and rotate handle 90° right or left to engage securely in a locked position.



**Figure 24. Purlin Brace Handle Properly Locked**

12. To lock the brace handle in position (as shown above), push the handle down along the surface of the arch frame. **DO NOT** place the handle into the purlin brace channel (i.e., pointing towards the ridge purlin).

13. The braces of the purlins along the ridge of the shelter are locked into position on alternate sides of the ridge. That means that if you rotate the purlin at the ridge of the first module 90° to the left and lock it into place, you must rotate the purlin at the ridge of the second module 90° to the right before locking it into place. This alternation prevents cross-tensions and helps stabilize the shelter roof along the ridge.

14. Install standard purlins at the arch eave hinges in the same way as you have done at the ridge.

15. Next, install the purlins at the foot of the arch frame legs. Use standard purlins unless a doorway has been planned for the module. When installing a doorway purlin, you may find it helpful to place your foot on the threshold plate to hold down the purlin as the brace arm is guided toward the "keyhole" on the arch frame leg. Once the purlin stud is engaged in the keyhole, rotate the purlin handle 90° with your hand and secure the handle tightly in the normal way.

16. Repeat steps 3–15 for each of the remaining modules of the shelter. Make sure that each ridge purlin is affixed to the rigid arch frame first and then attached to the next free arch frame. Remember to install doorway purlins whenever called for in the Shelter Modules Plan.

**NOTE:** If you are unable to lock a purlin brace into the arch frame, loosen both brace handles and start procedures 11 and 12 again. Be sure that the arch frame has not been knocked askew and that each purlin brace stud can reach into its keyhole. If the brace handle is unwilling to rotate and lie down along the surface of the arch, do not force it. If you do, the brace stud will become damaged and will not fit into the keyhole.

17. When all five modules of the kitchen shelter are rigid and free-standing, check assembly fittings:

- securing pins are properly inserted;
- purlin brace handles are in locked position along the surface of arch frames;
- direction of purlin braces alternates along center ridge;
- doorway purlins are opposite one another on the frame assembly and positioned at the bottom on the arch frame legs.

#### **D. INSTALLATION OF COVERINGS**

##### **UNPACKING**

1. Unpack and set aside a covering appropriate for each module. Door sections can be distinguished from window sections simply by unfolding part of the covering and inspecting for the doorway cut-out and extra canvas which forms a transition piece that connects to the vestibule. The supervisor may refer to the NHE Component Matrix (Table 1) to determine the overall number of coverings required for each shelter. The supervisor may also refer to the Shelter Modules Plan as a guide to determine which type of section to use.

2. Unpack and lay out two (2) end curtains for the shelter being assembled. Note that each end curtain is standard and will accommodate connection to a vestibule.

## END CURTAIN INSTALLATION

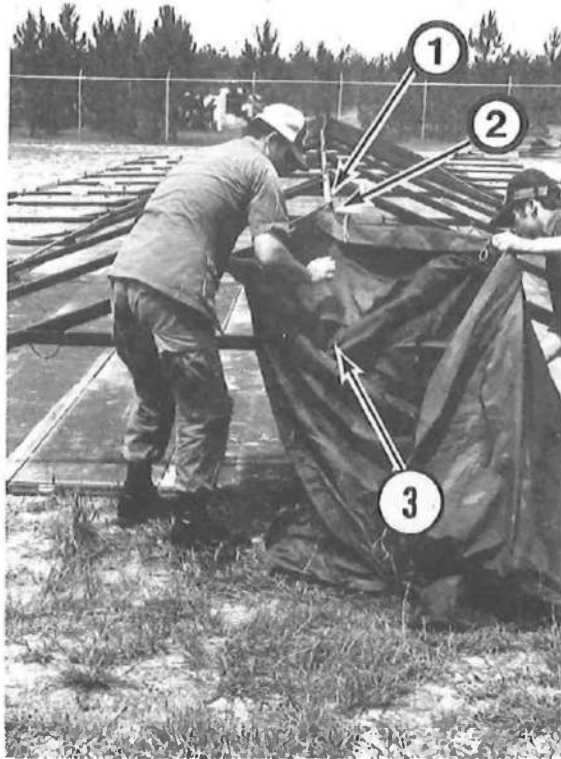

1. Arch Ridge Extension
2. End Curtain Center Grommet
3. End Curtain Vent

**Figure 25. End Curtain Installation**

3. Arrange one (1) end curtain alongside the header cross-piece. One person locates the end curtain peak and identifies the peak grommet (which is above the vent). Place the peak grommet over the arch frame extension. Draw the end curtain along the frame beyond the eave hinge. Check to be certain that the end curtain is hanging down, free and untangled. Leave the end curtain as it is for the moment.

## ROOF BLANKET INSTALLATION



Figure 26. Roof Blanket Draped Across Frame

4. A team now works together to carry the roof blanket to the middle of the module. Locate the center ridge grommet and stretch the covering in opposite directions until the center grommets can be placed over the arch ridge extensions. At this point one-half of the roof blanket should be on either side of the ridge purlin. This gathered piece can now be carefully drawn over the eave purlins and toward the base purlin. One person on each side locates the eave grommet and places this part of the blanket on the eave frame pin.

5. Now locate the eave grommets of the end curtain and place them over the eave frame pins.

**NOTE:** Each side edge of the roof blanket is fitted with either loops or grommets.

As you stretch each blanket over the frame you must insure that the edge fitted with loops on one blanket lies underneath the edge fitted with grommets on the adjacent blanket. You do this at the eave pins by making sure that the two grommets that fit over each pin (one grommet from each of the two adjacent blankets) are placed over the pin in the correct order. At the ridge, however, you can make use of a small split in the edge of the blanket, close to the ridge grommet, that will permit you to adjust the edges so that the looped edge lies underneath the grommetted edge.

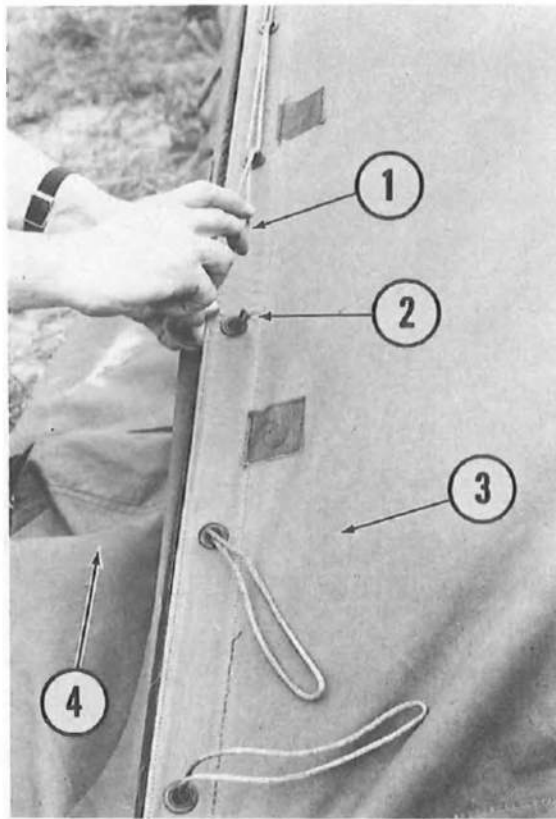

**Figure 27. Beginning the Becket Sequence at Arch Ridge**

6. The end curtain and roof blanket can now be joined together using a “becket” (loop and lace) sequence beginning at the arch ridge and proceeding as far down the frame as the eave hinge. Once this “becket” sequence is completed down both sides, the end curtain will be firmly attached to the roof blanket and to the arch frame. The same “becket” sequence is to be followed when engaging the loops and grommets of adjoining roof blankets. Finally, at the opposite end curtain of the kitchen shelter the same procedure will be followed as described in steps 7–12 to join the far end curtain and the last roof blanket to the arch frame. Procedures for the “becket” sequence are described next.

#### **BECKET SEQUENCE**

**NOTE:** The becket (loop and lace) sequence is used to join end curtains to roof blankets and to join adjacent roof blankets. The procedure in both cases is standard whether you stand outside the frame assembly (to join end curtain to roof blanket) or inside the frame assembly (to join two roof blankets). However, you may be more comfortable reversing your hands when working inside module.



- |                         |                            |
|-------------------------|----------------------------|
| 1. End Loop in One Hand | 2. Next Loop in Other Hand |
| 3. Roof Blanket         | 4. End Curtain             |

**Figure 28. Attaching the End Curtain to the Roof Blanket**

7. To becket the end curtain to the first roof blanket, pass the first loop (at the top, nearest the ridge) through the first grommet. While holding this loop with one hand, pass the second loop through the second grommet.



**Figure 29. Passing Second Loop Through First Loop**

Pass loop entirely through the grommet in the roof blanket and then through next loop held in other hand.

8. Pull the first loop down towards the second grommet, and pass the second loop through the first loop.



**Figure 30. Drawing First Loop Taut by Pulling  
Second Loop Down**

9. Draw the first loop taut by pulling the second loop down along the frame assembly toward the eave pin.

Repeat this process with every loop until you have only two loops remaining—the bottom loop (next to the eave pin if, as in this example, you are becketing from the ridge to the eave).

10. Then take the next end curtain loop in your free hand and repeat this “becket” sequence (7–9) working downward along arch frame toward the eave hinge. Complete each individual “becket” by pulling the loop taut to insure that the coverings fit snugly along the frame.

Finish off the "bucket" sequence at the eave hinge by following these steps:

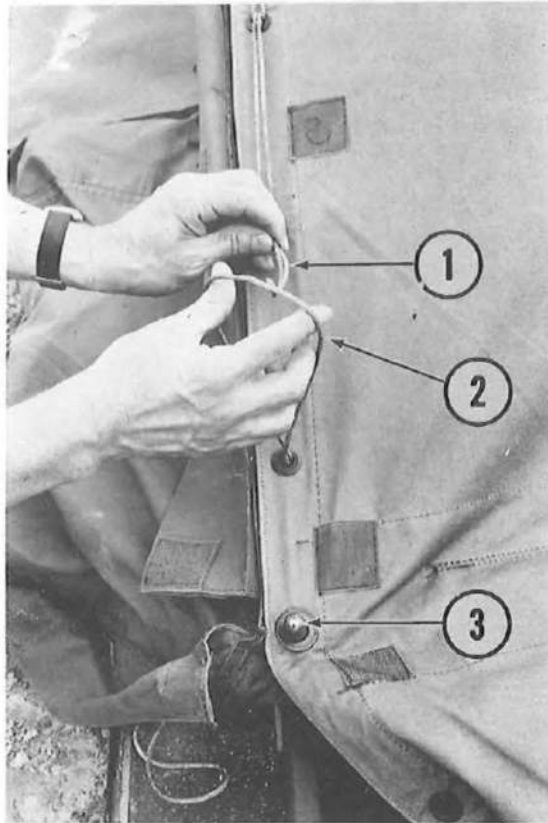

1. Next to Last Loop
3. Eave Pin

2. Last Loop

**Figure 31. Finishing the Bucket Sequence at the Eave Hinge**



**Figure 32. The Reverse Becket Procedure**

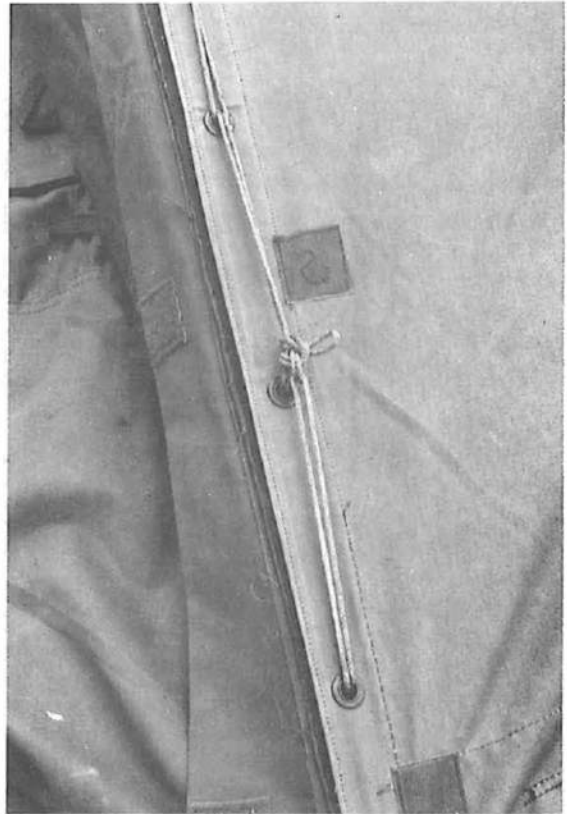
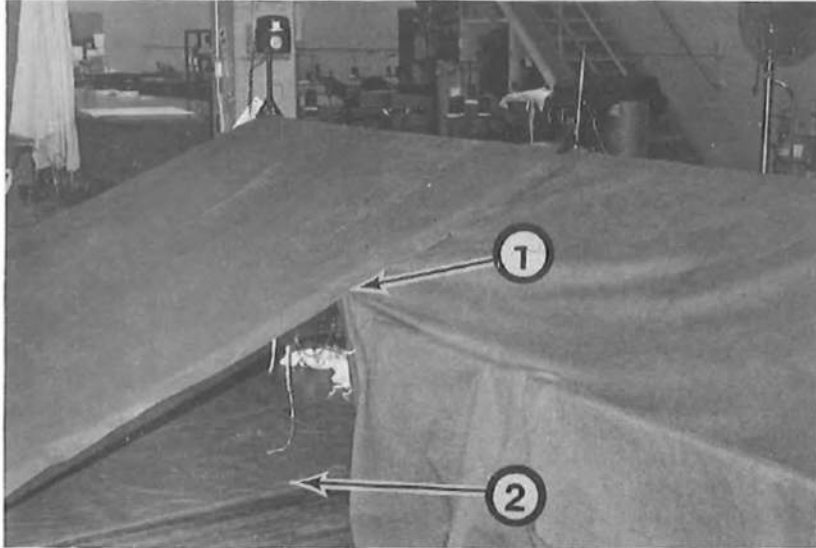

**Figure 33. Finishing the Becket Sequence**

11. Take the final end curtain loop in one hand and hold the next-to-last loop through the last loop to be becketed as in A above, and then pull taut in the direction of the ridge (contrary to usual procedure).

12. Pull next to last loop taut in the direction of the ridge and finish off this final becket by tying two half-hitch knots as shown in photograph B. Be certain that your half hitches do not loosen up as they may loosen all previously becketed loops.

13. Inspect all becketed loops to insure that the coverings fit tightly on the arch frame as this can help prevent rain from seeping into the shelter. When the "becket" (loop and lace) sequence is satisfactorily completed, then the pair works together to cover the loops with flaps sewn along the outer edge of the covering. Fold the flap over the becketed loops and press the Velcro patches together to seal the edge.



1. Becket Sequence Half-Way to Eave      2. Walk Space Between Modules to Eave

**Figure 34. Becket Sequence Half-Way to Eave Hinge**

14. When joining blankets inside the frame assembly, the pair should stand on opposite sides of the center ridge purlin. Each person repeats the standard "becket" sequence starting at the arch ridge grommet and moving down along the frame but only as far as **half-way** to the eave hinge. This will allow walk space inside the module frame assembly for the installation of the ridge extenders and fly.

## FRAME EXTENDERS

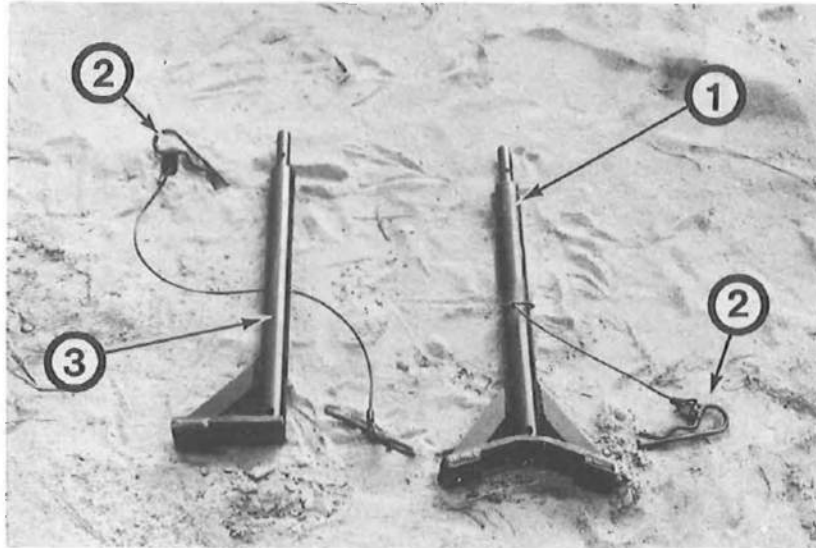

- 1. Ridge Extender
- 3. Eave Extender

- 2. Securing Clips

**Figure 35. Ridge and Eave Extenders and Securing Clips**

15. One member of each pair selects from among the component parts one (1) ridge extender and two (2) eave extenders for each arch. Check to be certain that every extender is equipped with a securing clip at its base and top, which will be used to lock it into position on the frame assembly. Also, attached to each eave extender should be a guyline long enough to reach the ground (12–15 feet).

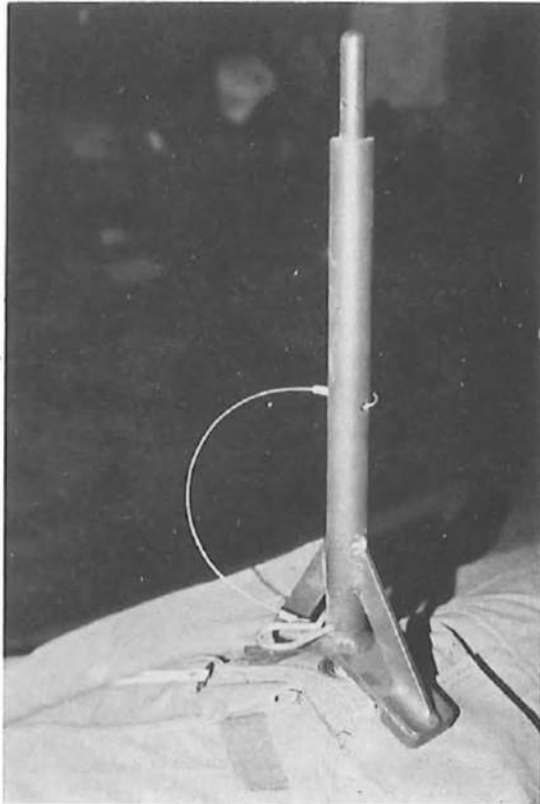

**Figure 36. Installed Ridge Extender**

16. Install the ridge extender by simply placing its hollow barrel over the frame extension post at the ridge. To do this, you will need to stand inside the module and as close to the ridge purlin as the partially becketed roof blanket will permit. Reach up with both hands and, while holding the ridge extender with one hand so that the hole in its base is aligned with the hole in the frame extension pin, push the base securing clip with the heel of your other hand through both holes until it locks into position.

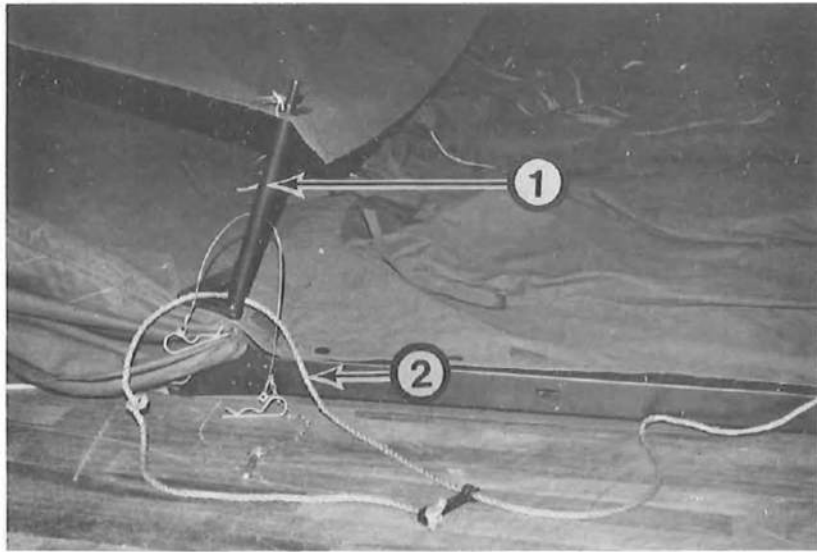

1. Eave Extender Installed

2. Guyline

**Figure 37. Installed Eave Extender**

17. Install each eave extender in a similar fashion by placing its barrel over the frame extension post at the eave hinge. Likewise, secure the base clip into lock position after aligning the holes in the eave extender and frame. Note that the "L-shaped" base of the eave extender must be pointing up the frame toward the ridge in order to provide maximum stability during fly installation.

**NOTE:** The eave extenders cannot be installed until the roof blankets are joined.

## FLY INSTALLATION

18. Unpack enough coverings to provide a fly for each module. Thus, for the kitchen shelter, three flies will be needed: two (2) 16' and one (1) 8' fly coverings.

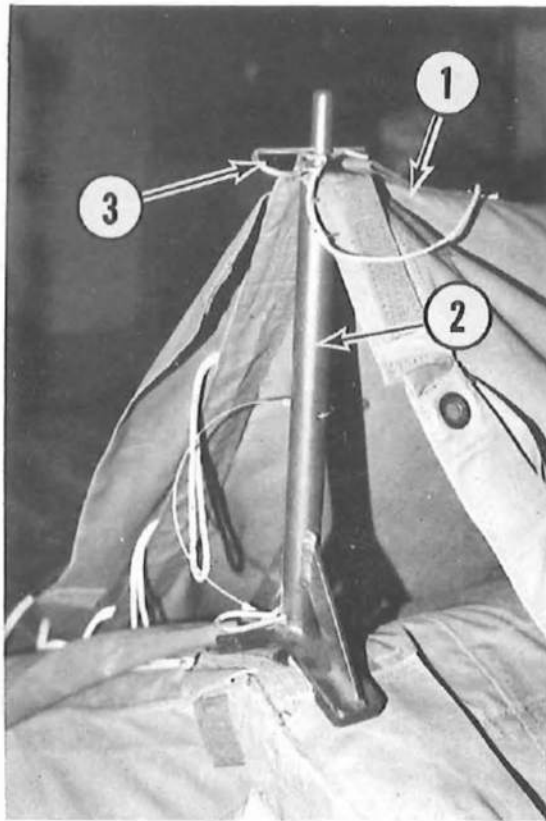

- 1. Fly
- 2. Ridge Extender
- 3. Securing Clip

**Figure 38. Fly Drawn Across Frame Assembly on Top of Roof Blanket**

19. Unfold the fly and, working together, each pair carefully draws the fly across the frame assembly on top of the roof blanket. Identify the ridge grommet (center point on edge of fly) and place it over the top of the ridge extender. Now, insert the securing clip through the top holes of the ridge extender and lock into position above the fly.

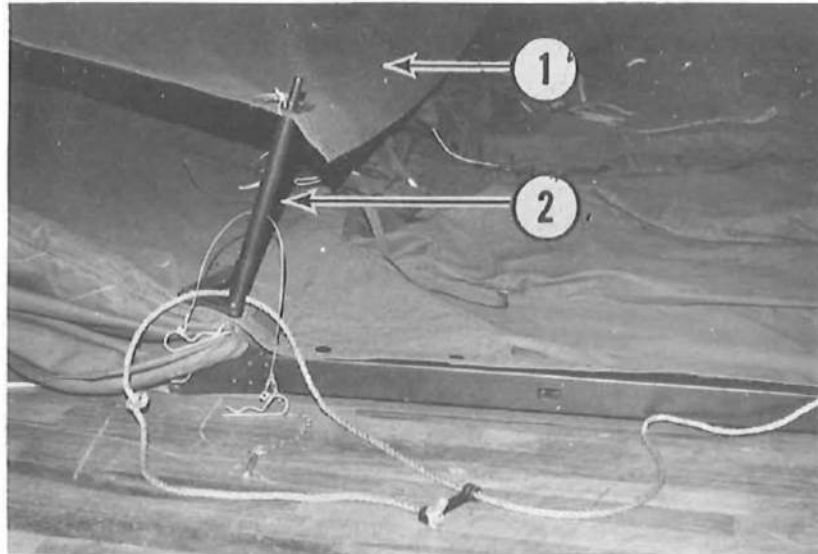

1. Fly

2. Eave Extender

**Figure 39. Fly Attached to Eave Extender**

20. Once the fly is secured atop the ridge extenders of each module, attach the fly to the eave extenders. Take care that the loop side of one fly can be installed at ridge and eave, yet the grommet side of the next fly is not to be attached at the eave. This will provide a walk space into the module for performing the "bucket" sequence by which adjoining fly coverings are "looped and laced" together.

21. Follow the standard "bucket" sequence to join all the fly coverings of the kitchen shelter. When this is accomplished, it may be helpful to detach the fly at the eave extender in order to allow ample work space to complete the "bucket" sequence of the roof blankets from their half-way point down to the eave hinge.

22. After completing the "bucket" sequence for the roof blankets and flies, locate the eave grommets on both coverings and install in this order:

- a. roof blanket over eave post pin;
- b. eave extender on top of roof blanket; and
- c. fly atop eave extender.

Secure coverings in place by pushing the two securing clips into their lock positions.

23. Inspect all loops for a tight becket to insure that the roof blankets and flys are properly connected between modules and to the arch frame. Cover becketed loops with flaps by folding flaps over the pressing down on the Velcro patches. Note that it is easier to fold flaps over loops near the ridge before the coverings have been secured at the eave hinge.

## GUYLINES

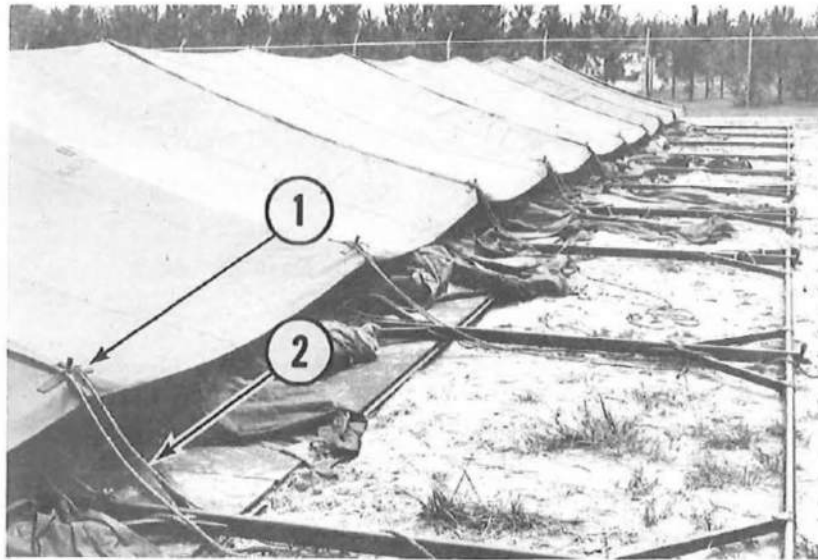

1. Canvas Loops on Fly      2. Guylines

**Figure 40. Guylines Passed Through Canvas Loops**

24. At the bottom of each fly, inspect the three canvas loops sewn to the fabric to insure that they are unobstructed. Pass the ends of the guyline through these canvas loops as indicated in the photograph above and pull these ends away from the eave so that the rope forms a taut crescent around the top of the eave extender and hangs freely down toward the ground.

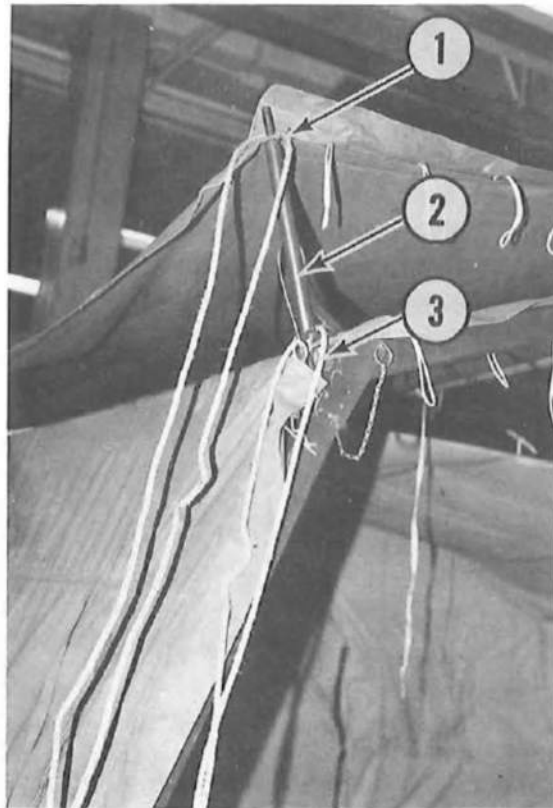

1. Guylines at Top of Eave
2. Eave Extender
3. Guyline at Base of Eave

**Figure 41. Guylines After Pulled Around Top Post Extension**

25. At each corner eave extender, thread the guyline through the canvas loops on the fly and pull taut around the top post extension so that the guylines hang down to the ground and are of equal length. Remember that guylines have already been threaded through the bottom of the eave extenders.

## **E. ERECTING SHELTER AND VESTIBULE**

### **RAISING THE SHELTER**

At this point, the shelter has been assembled, the roof blankets and end curtains installed and joined to the frame, and the fly has been installed and becketed together to cover the entire shelter roof. The shelter can now be raised.

It is imperative that one whole side of the shelter (i.e., six arches for the kitchen shelter) be raised at once. Therefore, it is recommended that the supervisor assign one person to

every arch frame leg. First one side of the shelter is lifted overhead in unison upon command and then the other side is raised upon command. For example, when the kitchen shelter is raised up, there should be six people to lift the arch frame on one side of the shelter.

After the arches have been locked into a raised position, then the six people move to the opposite side of the shelter and, upon command, each lifts one arch overhead and locks it in the raised position. Although a team of four plus one supervisor can swiftly and efficiently erect the kitchen shelter as few as three, as noted in the Overview, can accomplish the same task. A team of three, however, would assemble the modules as independent units, erecting them and then connecting them together, using the standard purlins.



1. Proper Crouch Position  
for Raising Shelter

2. Incorrect Position  
(Stoop)

Figure 42. The Correct and Incorrect Positions for Raising Shelter

**CAUTION:** The shelter assembly may weigh 600 pounds in total before erection. You will be lifting approximately 40 pounds at the eave hinge. It is suggested, therefore, that you crouch down and lift up on command so that the strain of the frame's dead weight will be carried by your legs and thighs, and not by your back.

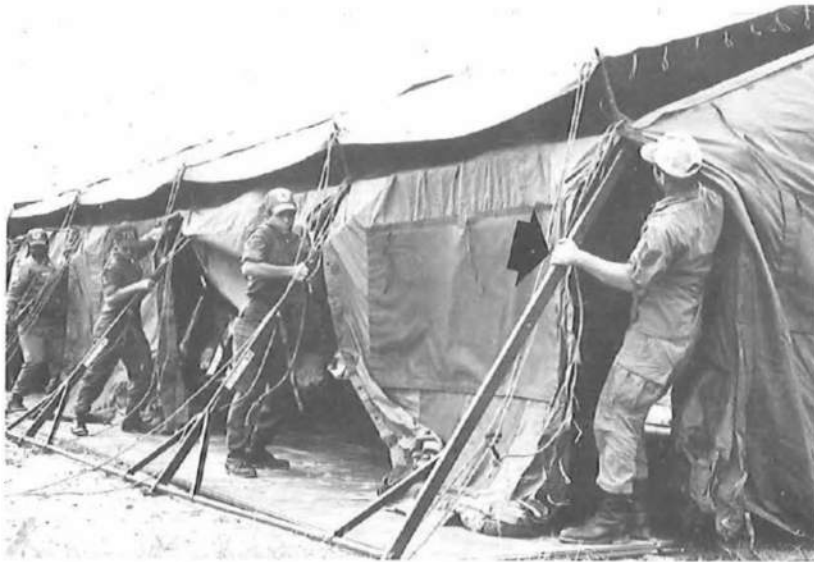

**Figure 43. Proper Position of Hand for Shelter Raising**

1. The two people assigned to the first and last arches should position themselves at the eave hinge so that one hand is under the arch frame leg below the hinge about 9" and the other hand is under the arch frame above the hinges about 9". Be careful that fingers do not move too close to the hinge itself while lifting the shelter or they may be pinched.

2. The persons assigned to the interior arches should position themselves at the eave hinge inside the module so that one hand is under the arch frame leg about 9" below the hinge and one hand is under the standard purlin crosspiece. Again, be careful to keep fingers away from the hinge to avoid being pinched.

**CAUTION:** Prior to the command to raise the shelter, you should check underfoot to be certain that your lifting will not be inhibited by tangled guylines or by stepping on a roof blanket.

3. When the supervisor gives the command to raise one side of the shelter, everyone should lift in unison with an even movement directly up and overhead. Once the eave hinge is overhead, each person shifts the outside hand on the frame leg to push down and inward.

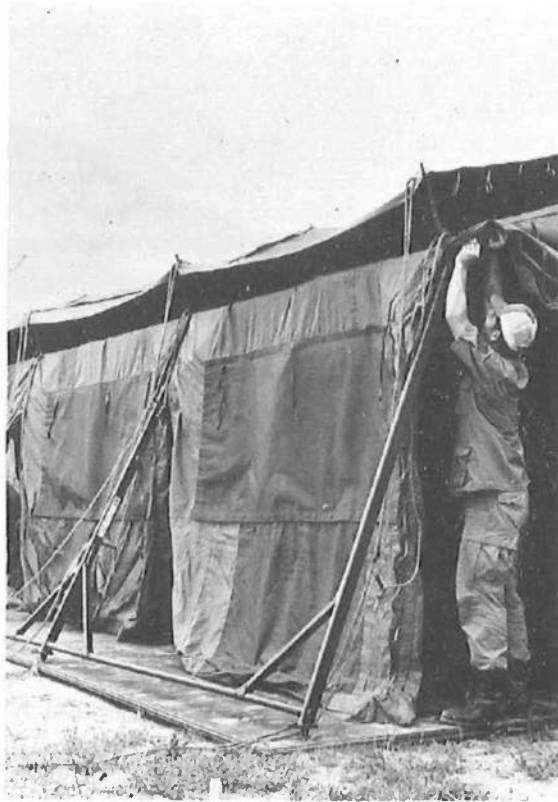

Figure 44. Securing Arch Leg in Open Position at Eave

4. This shift in the position of the outside hand will exert pressure to bring the eave hinge into a locked position—i.e., fully extended. Each person then reaches under the roof blanket, locates the hinge securing pin and inserts it into the eave hinge to lock it into this open position. Most of the weight of the shelter at this point will be distributed along the frame leg toward the ground and, therefore, it should be relatively easy to keep the shelter frame overhead with one hand while locking it with the other.

**NOTE:** No one alone should try to reposition an arch frame leg closer to a ground peg in the event that the arch leg has moved away from it. These individual adjustments weaken the eave hinges and may seriously damage the shelter frame. Whenever realignment is needed between the arch frame legs and the ground pegs of the **Layout Plan**, the supervisor should assign one person to each arch frame leg and in unison, **upon command**, the entire shelter should be hoisted off the ground several inches and repositioned. Never drag or push the arch frame leg across the ground.

5. The team now moves around to the opposite side of the shelter and prepares to lift it in the same manner as before. The supervisor insures that there is one person properly positioned at each arch and gives the command to raise the shelter. In unison, they lift the shelter frame overhead, reach under the roof blanket to locate the eave hinge securing pin, and insert it to lock the hinge in the open position. The kitchen shelter is now fully erected and freestanding.



**Figure 45. Attaching Guylines to Stakes**

6. Simultaneously, another team can pull the guylines taut that are attached to the corners of the tent at the eave and tie them to stakes driven into the ground. This will provide additional stability to the newly erected shelter.

7. Guylines from the middle eave extenders should be staked approximately 4 feet away from the arch frame legs and positioned straight out from the shelter (i.e., aligned with the arches) so that the guyline pegs form a straight row parallel to the shelter. The guylines from the corner eave extenders should be positioned at a  $45^{\circ}$  angle to the shelter but not so close to the entryway as to become an obstacle. Lastly, the guylines extending from the top ridge extenders should reach approximately 26 feet beyond the arch frame legs and be staked down at a slight angle from the center line of the shelter in order not to block the entryway.

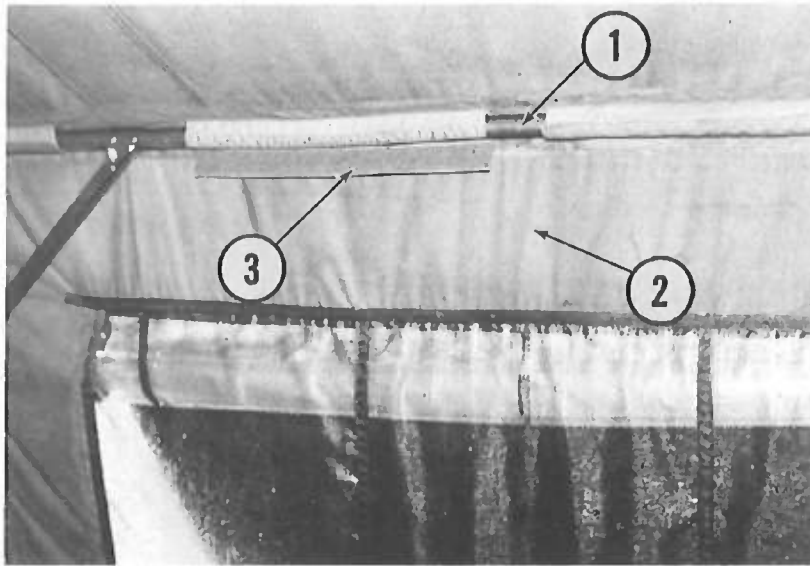

- 1. Purlin at Eave
- 2. Interior of Roof Blanket
- 3. Flaps with Velcro Patches

**Figure 46. Securing Purlin Coverings**

8. A team can now move inside the erected kitchen shelter and locate the coverings for the purlins. These are sewn to the inside of the roof blanket on the eave and baselines to help hold the blanket tightly against the shelter frame. Wrap these flaps around the purlin and press the Velcro patches together to secure the roof blanket to the inside of the frame. Begin with the flaps for the purlins that cross between the eave hinges and then secure the flaps around the ground-level purlins.

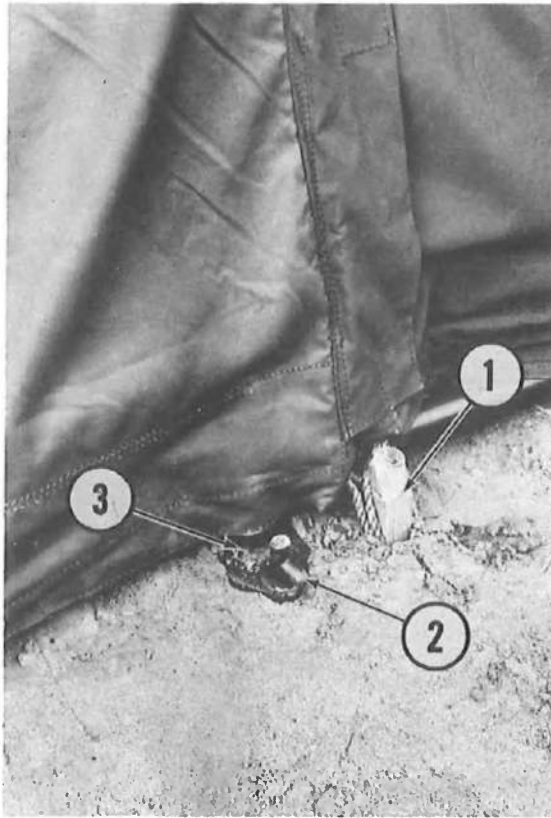

- 1. Wooden Ground Peg
- 2. Steel Stake
- 3. Arch Foot

**Figure 47. Steel Corner Stakes Inserted into Base of the Arch Frame Legs**

9. The supervisor should check the location of the frame legs of the erected shelter with the corresponding ground pegs and make any adjustments as needed to the shelter as a whole. Then, the steel corner stakes are inserted into the base of the arch frame legs at each corner. One person drives these steel stakes into the ground using a small sledgehammer. In high winds, it is important that these stakes be driven into position quickly to avoid having the erected shelter shift out of alignment with the **Layout Plan**.



**Figure 48. Tent Guylines in Place**

10. Once the shelter has been raised, these guylines will be pulled taut and staked down in order to create a tight shelter covering.

11. As soon as the correct positioning and alignment of each shelter can be verified, it is advisable to locate the aluminum ground stakes and drive them in to secure the shelter base. This should be done before the vestibule assembly, but after the interior roof blanket flaps have been tightly secured around the purlins.

12. Following the same procedures, the sanitation shelter and the dining shelter are assembled and erected next. Note that these shelters do not have a cotton liner and they have incandescent lighting rather than fluorescent.

#### **VESTIBULE ASSEMBLY**

**NOTE:** After the kitchen, sanitation and dining shelters have been assembled and erected, the supervisor should check the alignment of these shelters with the Layout Plan and insure that vestibules can reach between shelters, i.e., distance does not exceed 12 feet. Each roof blanket doorway has approximately one foot of additional fabric that forms a transition piece which can be joined to the vestibule blanket by engaging the loops in the usual becket sequence. This transition piece will thereby permit some leeway when connecting shelters.

1. Unpack vestibule frame assembly and lay out metal parts near the doorway opening of the roof blanket or end curtain. Also, unfold and set the vestibule blanket alongside.

2. Assemble vestibule frame by inserting the posts of the frame legs into the hollow barrels of the vestibule arch.

3. While one person holds the vestibule blanket in line with the grommets on the transition piece, the partner begins the becket sequence to engage the loops which join the coverings. Finish off the becket sequence with two half-hitch knots.



**Figure 49. Becketing Vestibule Cover to Transition Piece**

4. Locate the center and corner grommets of the vestibule blanket which has just been becketed to the transition piece. Carefully lift up one vestibule frame and insert its frame extensions (atop the arch) into these grommets.



**Figure 50. Vestibule Blanket—Securing Pins**

5. The vestibule blanket should be secured to the frame by inserting the pins attached to the outside of the blanket through the holes in the frame extensions. This covered vestibule frame may be leaned gently up against the shelter.

6. Place the remaining two (assembled) vestibule frames inside the vestibule walkway on the ground, but not underfoot where they may interfere with the next procedures.

7. Fully extend the vestibule covering until it reaches the roof blanket doorway transition piece of the next shelter. After aligning the center grommets of the two coverings, use the becket sequence to join the coverings. Again, the becket sequence is finished off by two half-hitch knots. Note that it is most efficient to have one person inside the vestibule walkway to hold the fabrics together and aligned while a partner stands outside the walkway and performs the becket sequence.

8. When the vestibule blanket is fully joined to the doorway transition pieces at either end of the walkway, the remaining two vestibule frames can be installed. Locate the center and eave grommets on the roof of the vestibule blanket and insert the arch frame extensions into these grommets. Lift upward slightly so that the vestibule frame legs can swing into an upright position and then lower gradually until the vestibule frame stands by itself, resting squarely on the ground of the walkway.

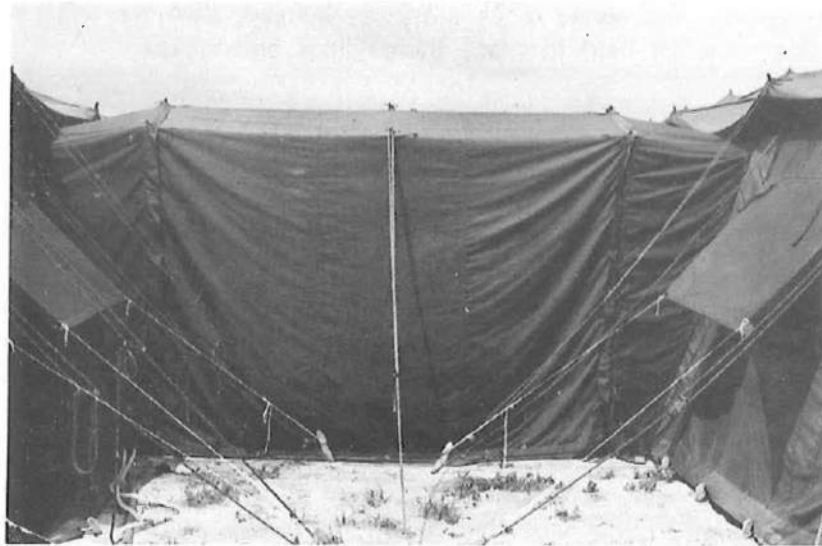

**Figure 51. Fully Installed Vestibule**

9. The vestibule blanket and three frame assemblies are now fully installed and form a covered walkway between adjoining shelters. Check to be sure that the becketed loops are tightly engaged and then cover them with the Velcro flaps in the normal way.

10. If the vestibule blanket is not stretched tightly across the arches, locate the tension strap which is inside the vestibule at the top of the doorway opening. Make certain that the strap passes from the vestibule into the shelter and around the purlin crosspiece before reentering the vestibule.

11. Take the strap end and pull it towards you to remove the slack in vestibule blanket. Use the Velcro patch to hold the tension strap in place.

12. Lastly, the guylines are attached through the loops on the vestibule and staked with 12" wood stakes. Twelve-inch steel pins are driven at the base of each arch.

**NOTE:** In cases where the vestibule does not connect two shelters as a passageway, but serves as an entryway instead, then the third vestibule frame must be held in place by guylines and stakes.



**Figure 52. Securing Vestibule End (Freestanding)**



**Figure 53. Vestibule End Curtain**

13. Identify the vestibule end curtain and install it over the mouth of the entryway.
  - a. Place the center ridge grommet of the vestibule end curtain over the arch ridge extension.
  - b. Place the corner eave grommets of the vestibule end curtain over the arch frame extension at the eaves.
  - c. When not in frequent use, or in stormy weather, the vestibule end curtain may be sealed by using the becket sequence to join the vestibule end curtain and the vestibule blanket down each side of the entryway.

#### **INSTALLATION OF SHELTER FLOOR COVERING**

The NHE kitchen shelter is equipped with a one piece, 40' x 20' vinyl floor covering. After the erection of the kitchen shelter, but before installation of the kitchen liner, this floor covering should be laid down.

In the event a kitchen shelter of fewer than eight sections is used, the 40 foot floor covering should be folded under.

The sanitation/storage/vegetable pyrocaction shelter floor is partially covered with a 32' x 20' vinyl covering. The covering is laid starting at the outer edge of the sanitation end of the shelter and extending from these sections.

## **F. INSTALLATION OF LIGHTING BARS IN KITCHEN, DINING, AND SANITATION/STORAGE/VEGETABLE PREP SHELTERS**

**NOTE:** The lighting bars, from which the kitchen lighting tubes are suspended, must be installed prior to the installation of the kitchen liner. The procedures which follow describe the standard method for positioning the lighting bars. At the discretion of the supervisor, the lighting bars may be installed before or after the kitchen shelter is erected.

1. Locate the aluminum lighting bars and lay out two (2) lighting bars for each module unit; i.e., the kitchen shelter requires ten (10) bars.
2. Using a ladder or similar object to stand on, install a lighting bar between each arch on both sides of the module. Clip the flexible, U-shaped clamp at either end of the bar around the header where it connects to the arch frame.
3. Repeat these steps to install all lighting bars. Where the U-shaped clamps on the end of the lighting bars clip onto the same header, be certain that the bars are as close as possible to the arch frame. Also, check to make sure that the lighting support straps (two per bar) hang down freely from the lighting bar.
4. Installation of the kitchen lighting bars is now completed and liner installation may begin.
5. Installation of the six lighting bars in the sanitation/storage/vegetable/prep shelter is done as described above. Two lights will be positioned in the sanitation area, two in the vegetable section, and two in the storage area.
6. A single lighting unit is to be installed for each dining shelter section.

## **G. LINER INSTALLATION**

**NOTE:** A plastic coated white liner should be installed inside the kitchen shelter to help maintain a clean working environment. Unless the NHE kitchen shelters are pitched in subnormal temperatures, this will be the only liner installed. The white liner is neither heavy nor difficult to tie into place. At the discretion of the supervisor, the liner may be suspended from the ridge purlins during the kitchen shelter frame assembly sequence as shown in some illustrations. However, to keep the white liner clean and dry, it is suggested that the liner be installed after the shelter has been raised and the vinyl flooring has been laid down.

1. Unpack the white liner, but do not unfold it.
2. Carry the liner into the kitchen shelter and unfold it partially on the kitchen flooring to determine whether it is an end-wall section or an intermediary section.

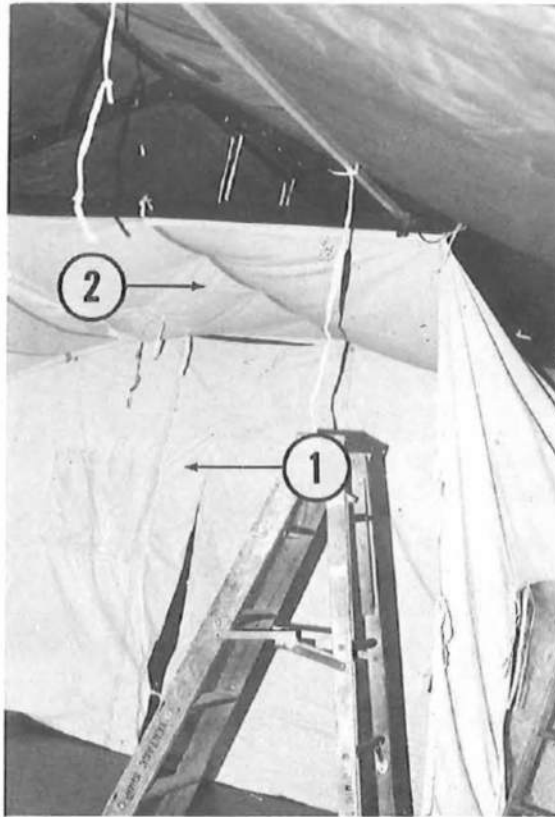

1. End-Wall Liner

2. End-Wall Liner Ceiling

**Figure 54. End-Wall Liner With Ceiling Installed**

3. Identify an end-wall liner and lay it out along the end-wall of the kitchen shelter. Locate the mid nylon strap and lift this part of the liner in order to attach the three straps to the ridge purlin of the arch frame assembly. Then attach the two ties to the center of the headers. Proceed to tie the remaining cotton ties all along the shelter frame so that the end-wall liner is stretched tightly across the frame from one side of the shelter to the other.

4. After the end-wall liner and ceiling is fully installed, locate an intermediary liner and spread it out between the first and second arches of the module. Identify the sides of the liner and its mid-point.

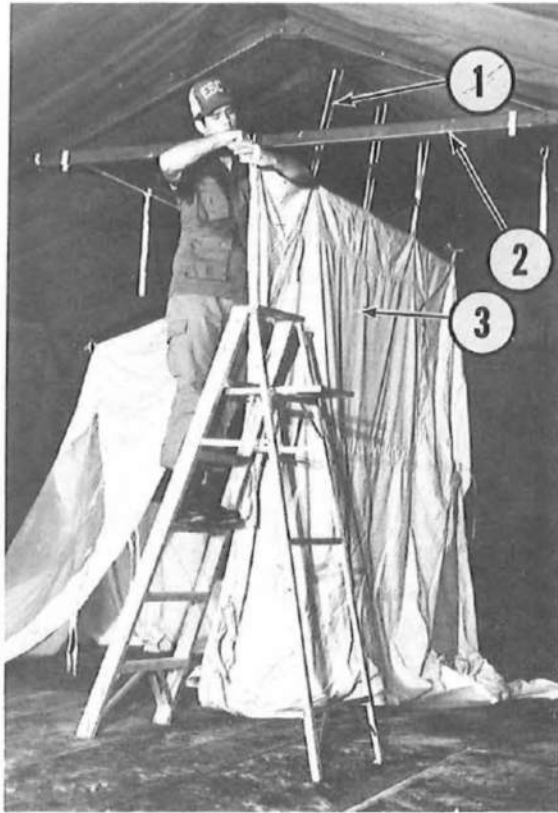

- 1. Nylon Strap
- 2. Header
- 3. End-Wall Liner

**Figure 55. Liner Being Secured to Header**

5. Identify the three liner roof straps and wrap the longer end of the strap around the ridge purlin (spacing them every 2 feet between the arches) and clip the snap hook to the D-Ring on the shorter end. These straps are adjustable—make certain that the liner is suspended about 18" below the ridge purlin and at a level. Then locate the cotton ties at the liner mid-points and tie them securely to the arch header, directly beneath the arch peak.

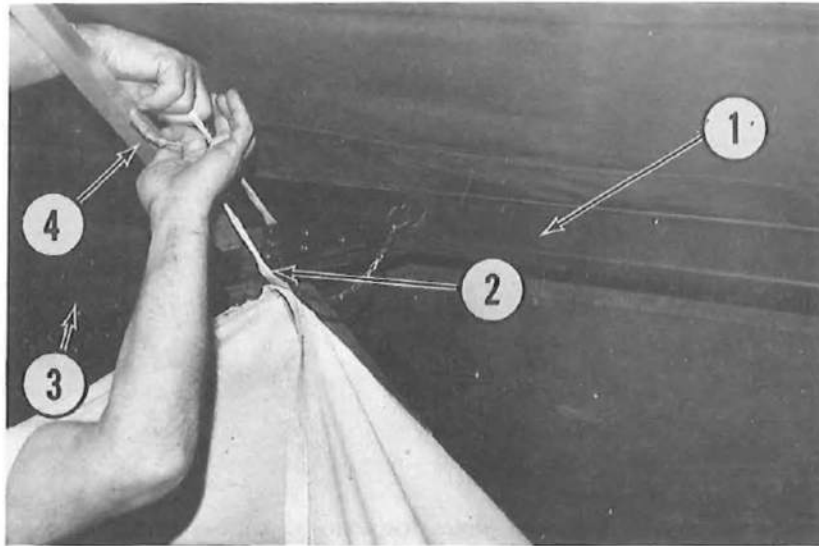

- |               |                     |
|---------------|---------------------|
| 1. Arch Frame | 2. Liner Cotton Tie |
| 3. Header     | 4. Lighting Bar     |

**Figure 56. Cotton Ties Secured Around Shelter Frame**

6. Find the remaining cotton ties sewn along the sides of the liner, wrap them around the shelter frame, and secure them in place with a bow-tie knot. Without over-stretching the liner, make certain that it is taut and is fastened to the frame assembly in such a way that the ties cannot slip closely together and cause the liner to sag. Note that in the picture above, the cotton tie is located at the extreme end of the header where the lighting bar can help hold the cotton tie in position.

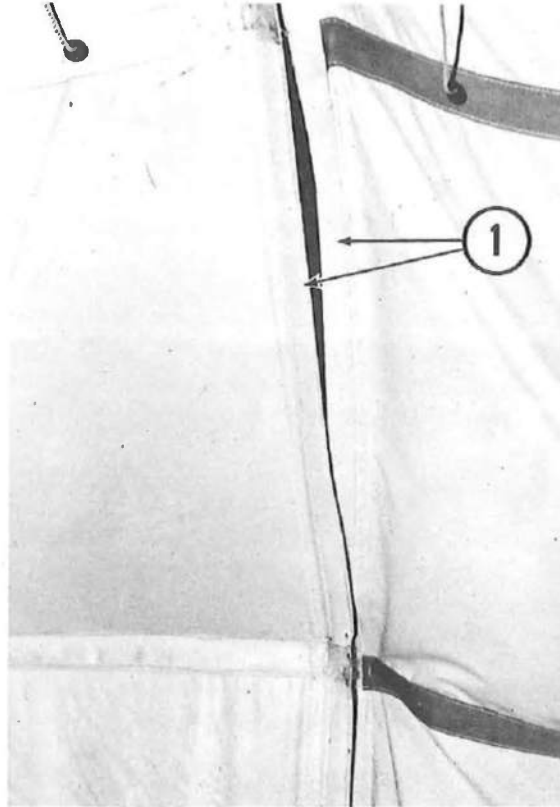

**Figure 57. Velcro Seam for Joining Liners Together**

7. Repeat these procedures for installing the appropriate intermediary liner in the next module. Note that unlike the roof blankets, the liners from adjoining modules are not becketed together. Instead, liners are joined by Velcro flaps provided along the edges. Simply press the Velcro flaps together to form a seal between liners.

8. When installing an end-wall and corner liner as described in steps 1–4, take special care that the ties on the doorway purlin are as far apart as possible, yet do not obstruct the threshold.

9. Lastly, fold the edges of the vinyl kitchen flooring up over the bottom of the liner to form a “seal” against the wind and rain. In the corners of the shelter, the flooring should be pliable enough to form an inverted “V” ( $\Lambda$ ) to seal and protect the bottom of the liner from spills.

**SECTION II**  
**NHE EQUIPMENT LAYOUT PLAN**

## OVERVIEW

The NHE shelter complex is designed to be compatible with US Air Force "Bare Base" operations. This complex represents the latest thinking on foodservice equipment and facilities available to the military. For its intended use in the field, the NHE complex incorporates modifications and improvements such as modular shelters, interchangeable coverings, versatile food preparation equipment, low-energy cooking and holding equipment, efficient sanitation and waste disposal, and use of "heat and serve" tray pack meals.

This complex can deliver high-quality, nutritious meals with great menu variety — normal full breakfast, simultaneous "two entree" and "short order" luncheons, a dinner from tray packs and a midnight meal.

Key pieces of equipment that have been substantially modified from standard field feeding operations are described in later sections of the Manual. This section describes a configuration for arrangement of these key pieces of equipment, including their relationship to other essential foodservice equipment. With minor adaptations, this NHE Equipment Layout Plan was successfully field-tested at Eglin Air Force Base, Florida, in June 1980. However, this configuration for system layout should serve the foodservice supervisor as a guide for instructional purposes and as an aid to planning actual positions for NHE equipment that will best accommodate each mission's contingencies.

## TRAINING OBJECTIVES

The trainee must be able to demonstrate a capability to plan and layout the foodservice equipment for the NHE system:

1. Identify the key pieces of interior and exterior foodservice equipment and describe their use.
2. Plan for appropriate location of key pieces of equipment and define the special requirements of these items.

## EQUIPMENT LAYOUT PLANS

The NHE Equipment Layout Plan is a floor plan showing the location of key pieces of interior and exterior foodservice equipment at maximum system capacity. Spacing of equipment inside the NHE shelters will naturally be influenced by the exact modular arrangement of the three shelters.



Table 2

List of Equipment by Functions\*

Food Preparation Equipment

1. Tilt Frying and Braising Pan (9" Deep)
2. Fryer, Deep-Fat
3. Ventilator, Proximity
4. Filter, Grease
5. Potato, Extruder, Automatic
6. Potato, Extruder, Manual
7. Griddle Assembly
8. Cook-Pot Assembly
9. Oven, Field, Assembly
10. Coffee Dispenser
11. Coffee Brewer, Automatic, 5 Pot
12. Coffee Brewer, Automatic, 2 Pot
13. Vegetable Slicer
14. Meat Slicer
15. Can Opener "T" Ration
16. "T" Ration Safety Lifter
17. Sink, Vegetable Preparation
18. Ice Machine
19. Toaster, Conveyor, Electric
20. Table, Food Preparation

Food Serving Equipment

21. Warming Cabinet
22. Steamtable Assembly
23. Beverage Dispenser (2)
24. Milk Dispenser

Sanitation Equipment

25. Sanitizing Sink W/2 Drain Tables
26. Water Heater and Circulating System
27. Grease Trap Assembly
28. Storage Racks
29. Handwashing Sink

Refrigeration Equipment

30. Refrigerator, Mechanical, Portable, Walk-In
31. Refrigerator, Upright Reach-In

Dry Storage Equipment

32. Shelving Assembly

Remote Tank Burner System

33. Fuel Main Supply Tanks
34. Compressor, Air
35. Fuel Lines
36. Tankless Burner Unit

Power, Lights and Heating Equipment

37. Generator, 60 kw, 3 $\phi$ , 4 Wire
38. Control Panel, 3 $\phi$ , 4 Wire
39. Lights, Bruce, Plus Light Bars
40. Heater, Duct Type, Portable, 400,000 BTU
41. Fuel Barrel Diesel
42. Dining Tables

\*As Deployed at Team Spirit '81

\*Kim Hae, Korea

**SECTION III**

**OPERATION OF WATER HEATER – M80  
AND WATER PUMP UNITS**

## OVERVIEW

This section of the training manual provides instructions for assembly and operation of the water heater — M80 and water pump. The equipment and hoses link a water source to sinks inside the sanitation and storage shelter and provide hot water for sanitizing cookware.

The water pump is a centrifugal-type pump for supplying both hot and cold water. Once the pump is properly set up and primed with one quart of water, it runs automatically. The water heater is a self-contained unit with a high pressure oil burner, boiler, combustion chamber, limit controls and safety devices for automatic operation. Once started, it will run automatically to heat water up to 160° and maintain that temperature  $\pm 10^\circ\text{F}$ . Should the water temperature exceed 190°F, then the high limit control will automatically shut down the boiler.

During start-up procedures, a buzzer may sound. If this occurs, it means that the heater has automatically shut down. There is no present danger or reason to panic. Simply turn the heater switch to the OFF position and refer to the Procedures to Remedy Automatic Shutdown (Section E). Be certain that the trainee periodically reads the pressure and temperature gauges on the equipment to insure that the water system is operating smoothly.

## TRAINING OBJECTIVES

The trainee must be able to demonstrate the capability to:

1. Select a suitable site for location of the pump and water heater. (A suitable site is defined in terms of distance from water source, kitchen, etc., as described in this Manual.)
2. Set up the water pump for operation including the attachment of the appropriate water hoses and electrical lead.
3. Orient and set up heater for operation including the attachment of appropriate water hoses, fuel lines and electrical lead.
4. Set up fuel drum, install fuel vent-fill assembly in the drum and attach the return and supply fuel lines from the heater to the corresponding fitting.
5. Perform the pre-start-up checks and start water pump.
6. Perform pre-start-up checks and start heater.
7. Adjust fuel/air mixture for proper burning of heater.
8. Adjust flow of water to sink faucets.
9. Take corrective action in event of flame safeguard control "cut-off."
10. Shut down the heater and pump and prepare for storage.

## **SPECIAL CONSIDERATIONS**

- Heater weighs more than 400 pounds. Thus, at least four people will be needed to carry it—though six would be better.
- The water source for training purposes may be any non-pressurized source like the military 400 gallon tank-trailer system.
- The three-phase electrical motors of the pump and heater must be in phase and rotating in the correct direction. An electrician is required to resolve any problems with the power source, including changing electrical leads.

## **EQUIPMENT AND SPACE REQUIREMENTS**

1. Water pump.
2. Water heater – M80 with stack assembly.
3. (1) 5' (1-1/2") hose for water connection.  
(2) 25' (1") hose for water to faucets.  
(1) 25' (1") hoses for pump to water source.  
(2) 12' fuel lines (should be already attached to heater and stored in a coil under boiler).

**NOTE:** The number and length of hoses for the water heater and pump are standard. If a particular mission is likely to require either more hoses of the same length or longer hoses, then these should be requisitioned prior to deployment.

4. Electrical lead with two plugs for heater and pump.
5. 55-gallon fuel drum with a vent-fill assembly.
6. Adjustable crescent wrench.
7. Container for water to prime pump.

## A. LOCATING PORTABLE WATER HEATER AND WATER PUMP

**NOTE:** The location of the water heater in relation to the water source, the power source, the fuel drum and the kitchen area is important. Try to follow these rules when choosing a site for locating the heater and pump.



1. Hot Water Heater  
3. Fuel Drum

2. Water Pump

**Figure 59. Placement of the Water Heater, Water Pump, and Fuel Drum**

**Place the heater:**

- less than 20' from the water source;
- less than 25' from the kitchen sink;
- less than 25' from the power source;
- downwind from the dining shelter (if possible).

**Place the water pump:**

- less than 20' from the water source;
- within 5' of the water heater.

## B. SETTING UP THE WATER PUMP



- |                                   |                             |
|-----------------------------------|-----------------------------|
| 1. Electrical Plug Connection     | 2. Discharge Hose to Heater |
| 3. Suction Hose from Water Source | 4. Priming Cap              |

**Figure 60. Major Parts of Water Pump**

1. Place the water pump so that the 1" QD coupling (suction) that will be attached to the hose leading to the water source is pointing towards the water source, with the other end (discharge) pointing towards the heater.

2. Select the 1-1/2" hose (approximately 5 feet long) from the collection of hoses that accompanies the water pump and attach one end of it to the 1-1/2" QD coupling on the pump.

This will be the main discharge hose. The other end of this hose will be attached to the portable heater.

3. Select a length of 1" hose, sufficiently long to reach from the pump to the source of water. Attach one end of this hose to the 1" QD coupling on the pump that leads to the water source.

This will be the suction hose.

4. Select a length of 1" hose, sufficiently long to reach from the pump to the kitchen sink. Attach one end of this hose to the 1" QD coupling on the pump that leads to the cold water pot filler.

This will be the cold water discharge hose.

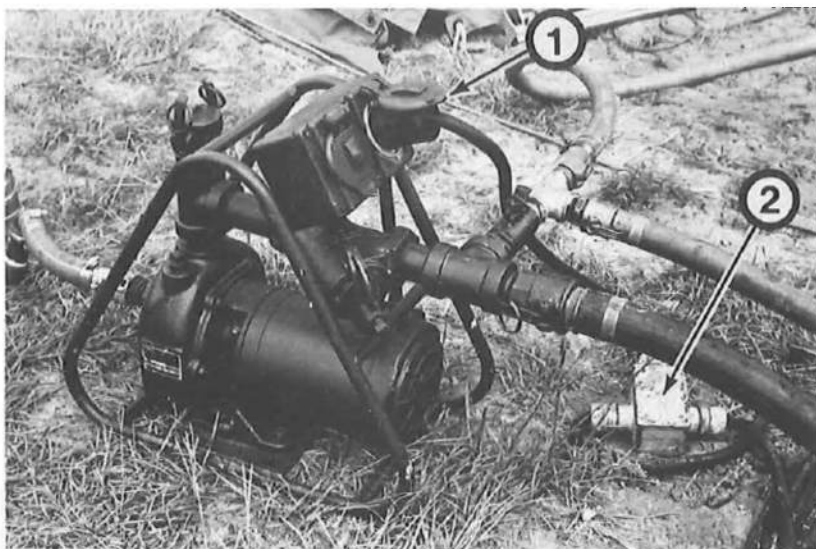

1. Electrical Plug Connection      2. T-joining Electrical Box

**Figure 61. Electrical Plug Connected to Pump**

5. Uncoil the electrical lead. You will find a T-joint box close to one end of the lead. Select the plug at the short end of the lead and plug it into the electrical outlet on the pump. To do this:

- a. lift the rain cover protecting the outlet,
- b. insert the plug at the end of the electrical lead into the outlet and apply light pressure while rotating clockwise until it slides into position. (A glance at the pins on the face of the plug before inserting it into the outlet will tell you why the plug will only fit in one position.)

**CAUTION:** If there are any water puddles nearby, avoid bringing live electrical leads into contact with water.

6. Check the pump drain valve to insure that it is fully closed. This valve is fully closed when the screw plug is fully out. Turn the plug clockwise to insure that it is fully out.

### C. SETTING UP THE WATER HEATER

**NOTE:** Before setting up the water heater, visually inspect the outside of the heater for damage that may have occurred during shipment or storage. Insure that there are no signs of fractures, splits, punctures, dents or deterioration.

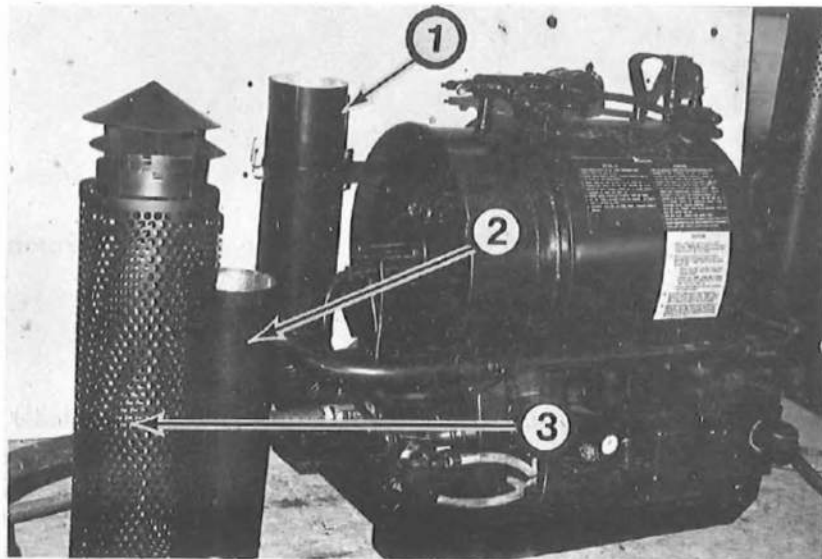

1. Lower Exhaust Stack Section on Heater
2. Upper Exhaust Stack Section
3. Smoke Stack Guard

**Figure 62. Water Heater in Preoperational Mode**

1. Unpack the smoke stack. Set up the smoke stack by first inserting the upper section of the stack firmly into the lower section.

2. Drop the smoke stack guard and raincap section over the upper section of the stack until the bottom of the raincap rests on the top of the upper section.

Position the guard so that the L-brackets attached to the lower section of the smoke stack are inside the guard, holding it away from the stack.

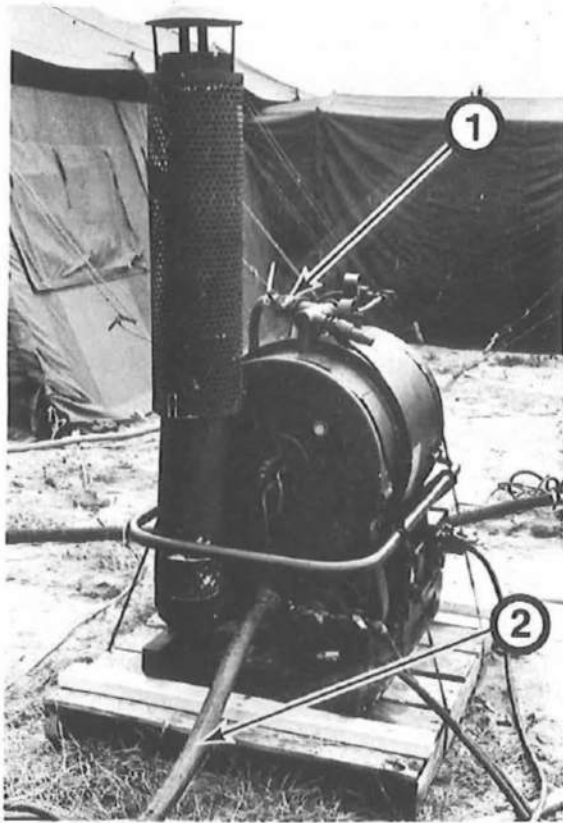

1. Cold Water Potfiller to Sinks    2. Intake Hose from Pump

**Figure 63. Hot Water Hose Attached to Heater**

3. Select a length of 1" hose, sufficiently long to reach from the water heater to the kitchen sink. Attach one end of this hose to the 1" QD coupling on the top of the water heater. The other end of this hose will be attached to the hot water pot filler.

4. Attach the 1-1/2" main discharge hose leading from the water pump to the OD coupling close to the base of the smoke stack.



**Figure 64. T-Fitting for Storing Fuel Lines**

5. Disconnect the free ends of the two fuel lines that are attached to a T-fitting at the base of the water heater. (The position of this T-fitting is indicated by an arrow in the picture above.)

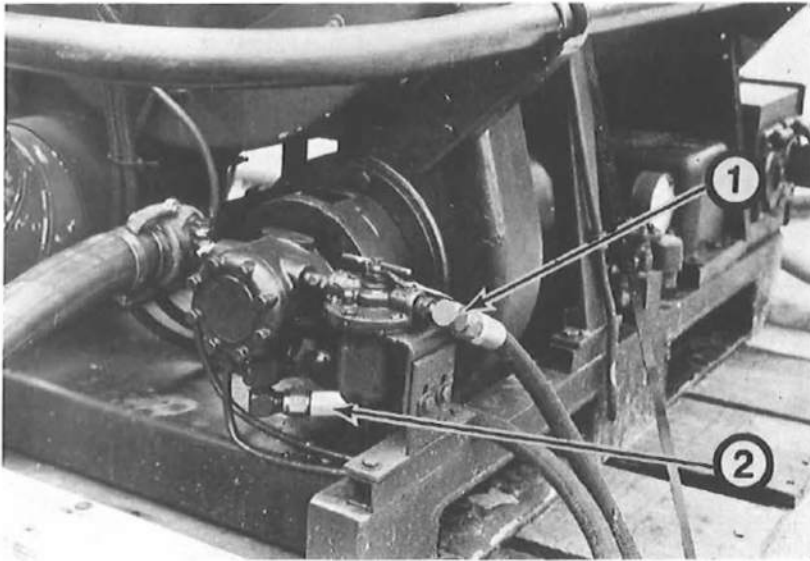

1. Supply Fuel Coupling

2. Return Fuel Coupling

**Figure 65. Fuel Lines Connected to Heater**

Uncoil the fuel lines and run them out to the 55-gallon fuel drum located nearby. When connecting the fuel lines to the vent-fill assembly, be certain that the "supply" fuel line is fastened to the "supply" fitting and the "return" fuel line corresponds with the "return" fitting.

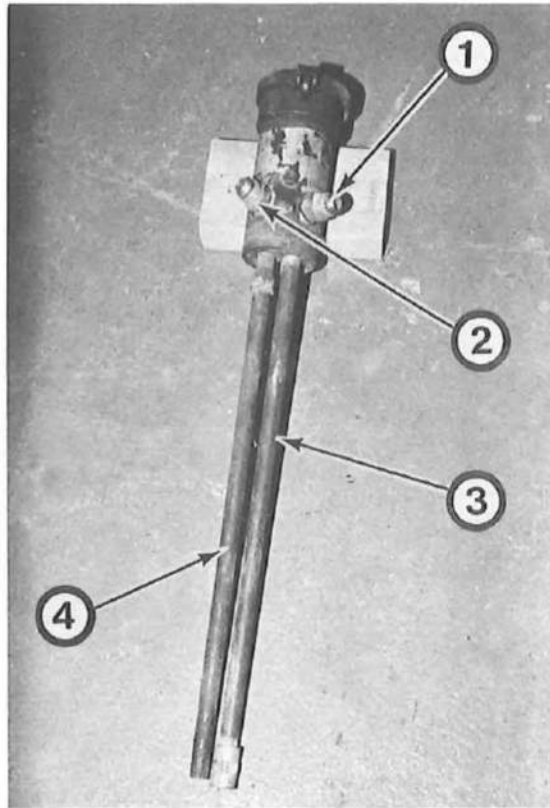

- |                   |                   |
|-------------------|-------------------|
| 1. Supply Fitting | 2. Return Fitting |
| 3. Fixed Pipe     | 4. Extension Pipe |

**Figure 66. Fuel Fill-Vent Assembly Prior to Installation**

7. Unpack the fuel fill-vent assembly and prepare it for insertion into the 55-gallon fuel drum:
  - a. unscrew the extension pipe on the underside of the fill-vent assembly;
  - b. attach the extension pipe to the fixed pipe—also on the underside of the fill-vent assembly—by screwing a lug nut until you have a tight connection.



**Figure 67. Fuel Fill-Vent Assembly Installed**

8. Unscrew the cap on the top of the 55-gallon fuel drum and insert the fill-vent assembly. Screw the assembly firmly into the drum.
9. Connect the supply fuel line to the "supply" fitting on the head of the fill-vent assembly. Next, connect the return fuel line to the "return" fitting on the head of the fill-vent assembly.

**NOTE:** The words "SUPPLY" and "RETURN" are clearly imprinted over the fittings on the fill-vent assembly. Trace each fuel line back to the fitting on the water heater to be sure that you have positively identified the supply fuel line and the return fuel line.

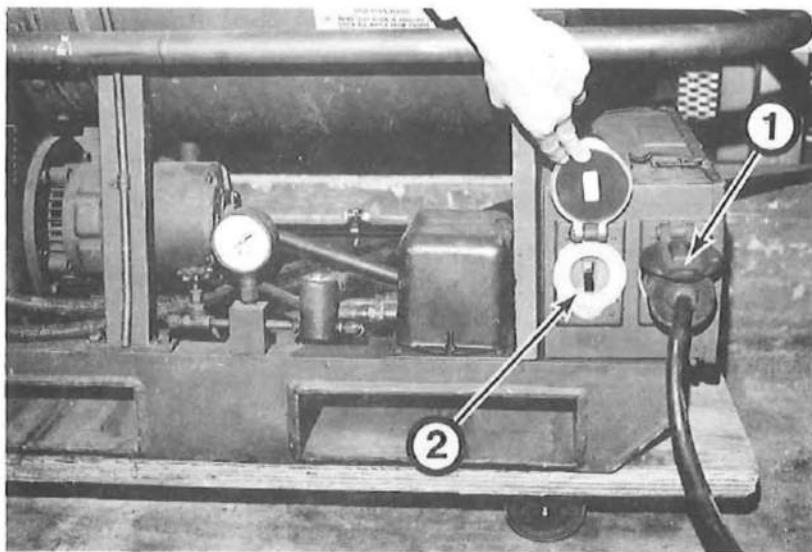

1. Electrical Plug Connection on Heater

2. ON/OFF Switch

**Figure 68. Electrical Lead Plugged into Heater**

10. Connect an electrical lead from the power source by taking the longer lead from the T-joint box and plugging it into an electrical outlet at the base of the heater. (Lift the rain cover, insert the plug and rotate it clockwise, applying light pressure until it slips into position.)

11. At this time, the hot water is fully set up and ready for operation.

## D. START-UP PROCEDURES

### WATER PUMP

1. Check that the ON/OFF switch of the pump is in the OFF position.

Turn the switch at the main electrical power panel to ON.



1. Water Pump ON/OFF Switch      2. Motor Casing

**Figure 69. Water Pump Switch and Motor Casing**

2. Momentarily turn the water pump "ON/OFF" switch to the ON position and check the direction of the rotation of the three-phase motor. To do this:

- a. flip the switch up;
- b. look into the motor casing and check the direction of rotation of the motor shaft;
- c. confirm that the motor rotates in the direction of the arrow marked on the pump housing;
- d. switch the pump OFF.

**NOTE:** If the motor rotation is incorrect (i.e., not in the direction of the arrow), turn the pump switch to **OFF** and call an electrician to reverse any two of the three power lines at the generator or at power source.

3. Prime the water pump by opening the priming plug and filling the pump with water. (It will hold approximately one quart.) The priming plug pulls straight out of the neck of the primer, but you may need to use a wrench (or pliers) to grip it sufficiently hard to twist it as you are pulling it out.

Replace the plug after you have primed the pump.



1. Priming Cap      2. Water Lever Valve in OPEN Position

**Figure 70. Water Lever Valves in OPEN Position**

4. Open all water lever valves and pot fillers on the pump and heater. Notice the lever valve position when "open" to allow cold water discharge from pump.

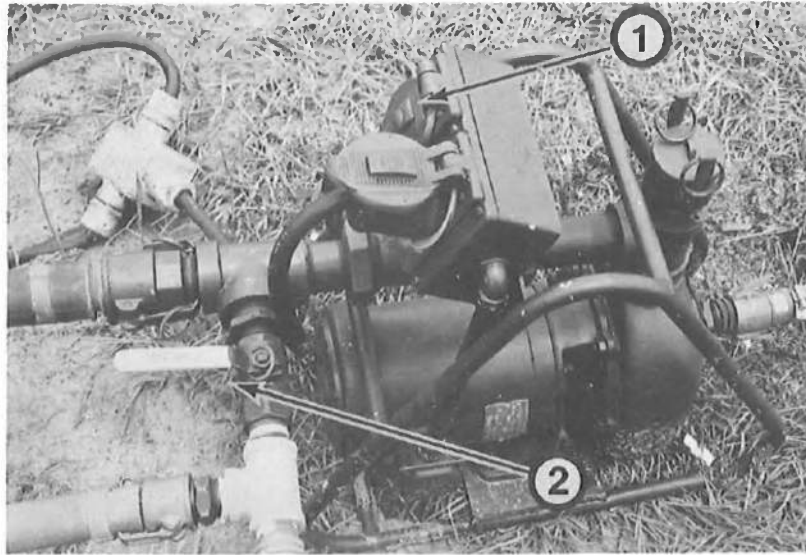

1. Water Pump ON/OFF Switch      2. Water Lever Valve in CLOSED Position

**Figure 71. Water Lever Valve in CLOSED Position**

5. Compare the lever valve position in the picture above when "closed" to allow cold water to flow into the heater only.

6. Switch **ON** the water pump. When water is flowing out of both the cold water pot filler and the hot water pot filler, then turn the pump **OFF** and close the lever valves of the pot fillers. You may also wish to open the manual cock valve on the top of the heater when testing water flow through the system and "bleed" the heater free of trapped air. The heater boiler has now been filled with water and the water heater is ready for operation.

**NOTE:** The water pump does not have to be operating when the heater is **ON**, but must be switched **ON** whenever the pot fillers are in use. If hot water is drawn from the heater when the water pump is not **ON** and operating, then the heater will automatically shut down as the water level drops inside the boiler.

**Cautions During Start-Up Procedures:**

1. If the fuel pressure gauge reads less than 100 p.s.i. or more than 120 p.s.i., **DO NOT OPERATE** heater. Instead, turn switch to **OFF** and call an engineer or mechanic.

2. When the burner motor is running, but no spark is seen through the ignition sight tube, DO NOT OPERATE heater. Instead, switch OFF heater and call an electrician.

3. If the fuel pressure gauge reads 100 p.s.i., a spark is visible across the electrodes but combustion does not occur:

a. check that the manual valve is OPEN;

b. check the water temperature gauge on top of the boiler. The flame will shut down automatically when water temperature rises above 190°F;

c. finally, call either an engineer or an electrician.

4. If the buzzer is going, the fuel pressure gauge reads 100 p.s.i., spark and flame are visible and pushing the reset button fails to silence the buzzer, then there is probably insufficient water in the boiler.

a. check the water pump—is it going? is it switched on?

b. check the water source—are you out of water?

c. check the pump strainer and the water hoses for blockages.

d. check for a suction leak in the hose or fittings—are all the fittings secure and airtight?

e. the heater may be air bound. Vent the air by opening any hot water faucet with the pump operating.

## WATER HEATER OPERATION

7. Check that the ON/OFF heater switch is in the OFF position.

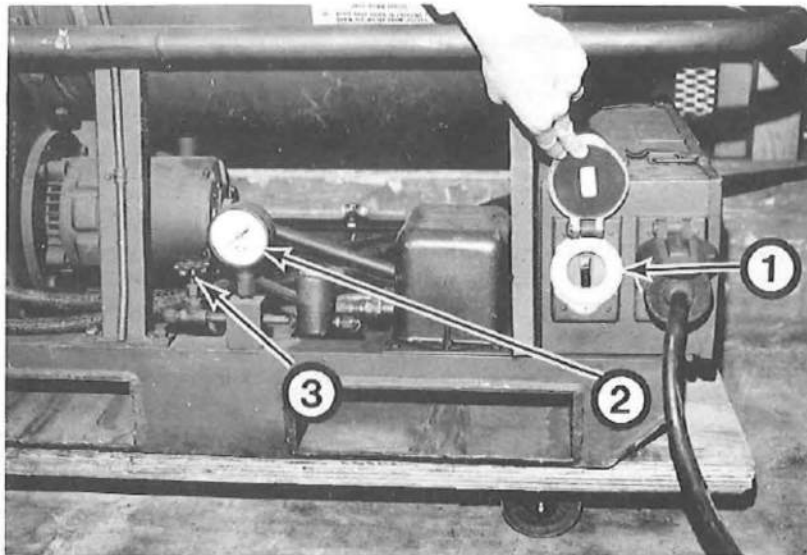

1. Water Heater ON/OFF Switch
2. Pressure Gauge
3. Manual Fuel Valve

**Figure 72. Water Heater Switch in OFF Position**

8. Close the manual fuel valve by gently turning it in a clockwise direction.
9. Turn the ON/OFF heater switch to the ON position. There will be a 7-second pause before fuel begins to flow through the fuel valve. After 7 seconds, the fuel pressure gauge should read 100 p.s.i.

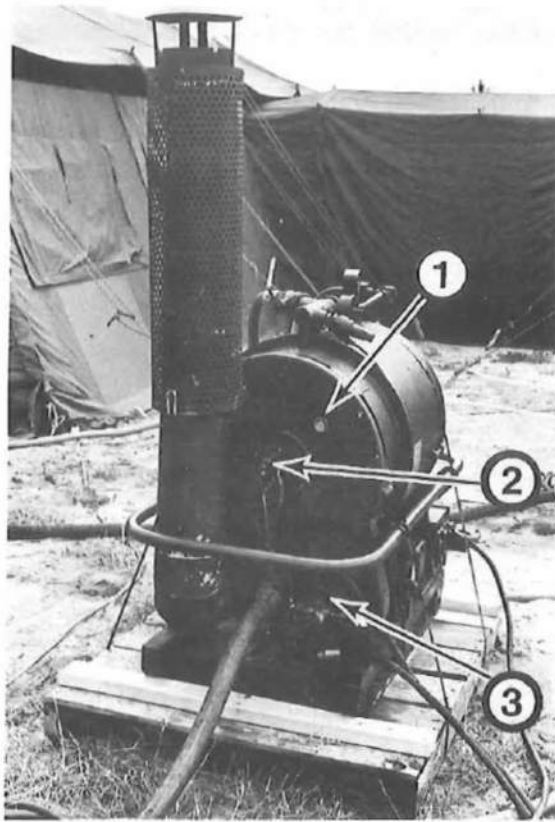

1. Combustion Sight Tube                      2. Ignition Sight Tube  
3. Manual Air Shutter

**Figure 73. Heater Showing Sight Tubes**

10. When the fuel pressure gauge reads 100 p.s.i., look into the window of the ignition sight tube to check that there is an ignition spark at the tips of the electrodes.

A continuous spark should be jumping across the gap between the tips of the electrodes at any time that the motor is running.

11. Open the air shutter approximately half-way.

12. Open the manual fuel valve fully by turning the handle counterclockwise. Combustion should take place immediately. Check for a combustion flame in the burner by looking through the window in the combustion sight tube.

13. Adjust the air shutter so that the exhaust gases coming from the smoke stack are transparent and smokeless.

If smoke is visible, slowly open the air shutter until the smoke disappears.

If no smoke is visible, slowly close the air shutter until the smoke becomes visible; then open the air shutter again to a point at which the smoke just disappears.

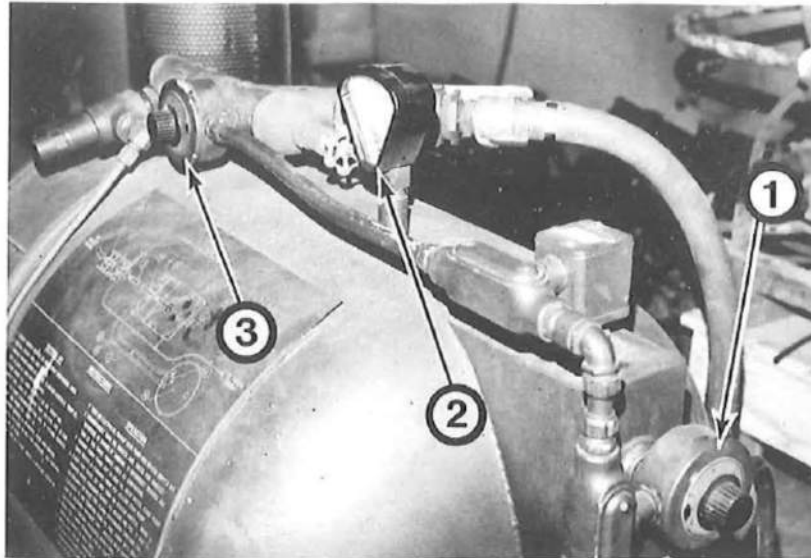

1. Operating Control  
3. High Limit Control

2. Operating Control Temperature Dial

Figure 74. Heater Operating Control Dial

14. Check the operating control dial to make sure that it has been set to the desired temperature for hot water . . . normally 160°F.

**CAUTION:** This boiler heats water rapidly. You should therefore be extremely careful when using the hot water pot fillers not to scald yourself.

15. If hot water is to be drawn from the system as soon as the water reaches the desired temperature, switch the water pump on.

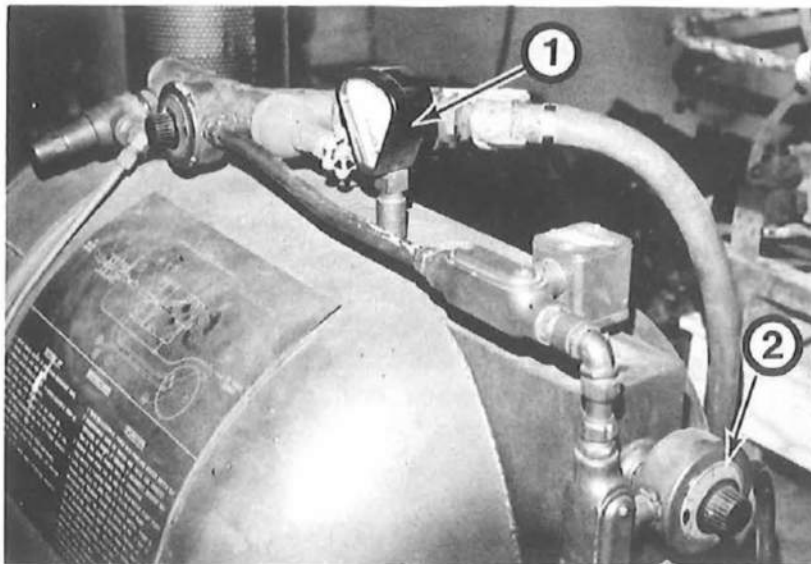

1. Operating Control Temperature Dial      2. Operating Control

**Figure 75. Water Heater Temperature Indicator and Operating Control**

16. When you have completed the start-up procedures, the heater should continue to operate automatically.

Under normal conditions, the heater will maintain a water temperature of  $160^{\circ}\text{F}$  ( $\pm 10^{\circ}\text{F}$ ).

17. When the temperature of the water reaches approximately  $160^{\circ}\text{F}$ , the operating control will automatically shut off the heater. Similarly, when the temperature of the water drops much below  $160^{\circ}\text{F}$ , the operating control will automatically trigger the heater to start up.

18. As a safety device, the high limit control will shut down the heater if the operating control fails. The high limit control is set to shut down the heater if the water temperature reaches  $190^{\circ}\text{F}$ .

19. Remember that the rate of water flow to the kitchen sinks may be controlled by adjusting the hot and cold water lever valves on the heater and on the pump which control water flow through the pot fillers.

#### **E. SHUTDOWN PROCEDURES**

1. Shut down the water heater by turning "ON/OFF" switch to "OFF" position.
2. Shut down the water pump by turning its switch to the "OFF" position.
3. After both heater and pump have stopped functioning:

- a. close the manual fuel valve on the heater;
  - b. disconnect water hoses and drain them;
  - c. disconnect fuel lines, empty them and reconnect them to fitting on the base of the heater frame.
  - d. disconnect power lines.
4. Open all valves, including the manual drain cock on the water pump and on top of the water heater, to drain pump and heater dry.
  5. Prepare pump and heater for storage.

#### F. RESTART PROCEDURES TO REMEDY AUTOMATIC SHUTDOWN OF HEATER

Because the fuel pump will only run for 30 seconds without combustion, the water heater will automatically shut down if the manual fuel valve is not open or if combustion does not take place within 30 seconds of turning on the heater switch.

The water heater will also shut down automatically if the water level in the boiler drops below a minimum level.

When an automatic shutdown occurs, a buzzer will sound.

When a shutdown occurs . . .

1. Turn the heater switch to the OFF position.

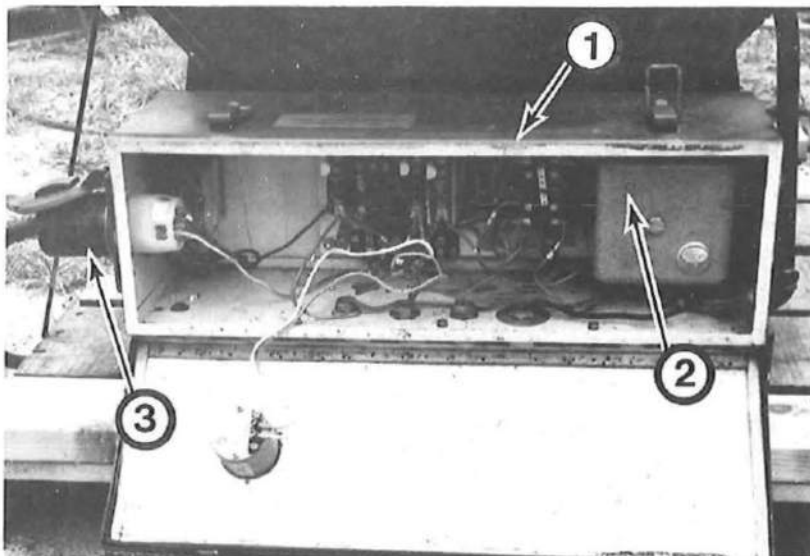

- |                                      |                 |
|--------------------------------------|-----------------|
| 1. Heater Control Box                | 2. Reset Button |
| 3. Electrical Plug and ON/OFF Switch |                 |

Figure 76. Major Parts Relative to Shutdown of Heater

2. Open the control box on the end of the heater and reset the flame safeguard control by pressing in the red reset button. The reset button is normally "in" but when heater trouble occurs, this button "locks out." First correct the trouble, then push the reset button back "in."

If the reset button will not remain in, it may be necessary to wait for approximately two minutes before resetting it again.

3. When the buzzer has stopped, begin the start-up procedures (steps 7–15 in Section D) again.

4. If the buzzer does not stop when the reset button is depressed, the cause of the automatic shutdown is a low water level.

Fill the boiler with water by switching on the water pump and opening the water valves leading from the pump to the heater and from the heater to the hot water faucet. Open the hot water pot-filler or manual cock valve on top of heater to insure that water is flowing freely and to show when the boiler is filled. Once the low water level has been corrected, depress the reset button and begin start-up procedures.

## G. MAINTENANCE PROCEDURES

### Pump

Routine maintenance like cleaning filters, hoses, and the exterior parts of equipment may be performed by food service personnel after proper instruction and demonstration. Other than routine maintenance, any equipment repair should be performed by the appropriate qualified engineers or technicians.



1. Pump "Bolt Arch"

2. Pump Filter Housing

Figure 77. Water Pump

Weekly (or whenever clogged) remove water pump strainer (screen) for cleaning in the following manner:

- a. unscrew bolt holding cap in place on filter housing by turning counterclockwise with adjustable wrench;
- b. swing "bolt arch" to one side—following downward arrow;
- c. remove pump strainer and wash clean;
- d. replace strainer;

- e. swing bolt "arch" upward and return into position.
- f. tighten bolt by screwing clockwise with wrench until base of bolt presses securely against metal place of strainer housing which protects the strainer (screen).

# WATER HEATER

Table 3. Maintenance Procedures for the Water Heater

Before Operation	Intervals		Procedure
	During Operation	After Operation	
X	---	X	<b>Burner.</b> Check nozzle and electrode holder for secure mounting.
X	---	X	Check lead assemblies for secure connections.
---	X	---	Check for proper combustion in firebox.
---	X	---	Check electrodes for proper spark.
X	---	---	Check for obstructions in scanner tube.
X	---	X	Check that scanner tube is secure and in proper location.
X	---	---	Check that face of UV scanner is clean.
X	---	---	Check that UV scanner is secure to scanner tube.
X	---	X	<b>Blower and blower motor.</b> Check mounting of blower and motor. Make certain shutter operates freely.
X	---	---	Make certain blower motor overload switch is not tripped.
X	---	---	<b>Load limit switch.</b> Make certain load limit switch is not ripped out on overload.
X	X	---	Check to be certain that the ground rod at generator is attached to the green wire (equipment ground). If not—do not operate water heater.

**Table 3. Maintenance Procedures for the Water Heater (cont'd)**

Before Operation	Intervals		Procedure
	During Operation	After Operation	
X	X	---	<b>Fuel Pump.</b> Make certain pump is primed. Make certain fuel lines are connected properly and that no leaks exist.
X	X	---	<b>Fuel Supply.</b> Check level of fuel supply. Fill if necessary.
X	---	---	<b>Power Supply.</b> Check power supply for proper connection.
X	---	X	<b>Gauges.</b> Check for broken lenses and loose connections.
---	X	---	Check for proper readings.
X	X	---	<b>Valves and controls.</b> Check for proper operation.
X	X	X	<b>Exhaust smoke pipe.</b> Check for tight connection. Make certain no breaks or leaks exist.
---	X	---	<b>Exhaust Gases.</b> Check exhaust gases for a light heat haze.
X	---	X	<b>Tools and Publications.</b> Make certain tools and pertinent publications are present and properly stowed.
X	---	---	<b>Hose.</b> Check the female end for missing or defective gasket.

## H. TROUBLE-SHOOTING PROCEDURES

The chart below lists the troubles that could be encountered during water heater operation.

**Table 4. Trouble-Shooting Procedures for the Water Heater**

Symptom	Possible Cause	Remedy
a. Water heater fails to start.	No electrical power to water heater.	Supply electrical power to heater.
	No electrical power out of load limit switch.	Reset load limit switch.
	Flame safeguard control lock-out switch tripped.	Reset flame safeguard control lock-out switch.
	Blower motor overload switch is tripped.	Reset blower motor overload switch.
	Defective flame safeguard control.	Replace with new control.
	Water heater not filled with water.	Fill with water.
	Defective low water probe.	Replace probe.
	Defective low water relay.	Replace relay.
	Defective contractor.	Replace contractor.
	Motor contractor is tripped.	Reset contractor.
	Defective Operating Limit Control.	Replace control.

Table 4. Trouble-Shooting Procedures for the Water Heater (cont'd)

Symptom	Possible Cause	Remedy
a. Water heater fails to start (cont'd).	Operating control setting too low.	Adjust operating control.
	Defective high limit control.	Relace control.
	High limit control setting too low.	Adjust high limit control.
b. Fuel pump fails to deliver fuel to burner.	Lack of fuel.	Fill fuel tank.
	Air leak in suction line.	Tighten suction line connection.
	Pump rotation reserved.	Interchange any two (2) of the three (3) 208 volt, 3-phase electrical supply lines.
	Supply and return line reversed.	Reverse fuel lines.
	Fuel pump strainer clogged.	Remove and clean strainer.
	Fuel nozzle clogged.	Remove and clean nozzle.
	Fuel pump drive coupling loose.	Tighten coupling.
	Magnetic fuel valve broken.	Install serviceable valve.
	No electrical power to magnetic fuel valve.	Replace flame safe-guard control.

Table 4. Trouble-Shooting Procedures for the Water Heater (cont'd)

Symptom	Possible Cause	Remedy
c. Noisy pump.	Suction line leak.	Tighten suction line connection.
	Fuel pump strainer clogged.	Remove and clean strainer.
	Fuel filter clogged or dirty.	Remove and clean filter.
d. Pulsating pressure indicated by pressure gauge.	Suction line leak.	Tighten suction line connection.
	Fuel pump strainer clogged.	Remove and clean strainer.
	Fuel filter clogged.	Remove and clean filter.
e. Fuel pressure too low on gauge.	Pump out of adjustment.	Adjust pump pressure.
	Fuel filter clogged or dirty.	Clean filter by turning handle on top.
	Fuel pump strainer clogged.	Remove and clean strainer.
	Pressure gauge defective.	Install serviceable gauge.
f. Fuel pressure too high on gauge.	Pump out of adjustment.	Adjust pump pressure.
	Pressure gauge defective.	Install serviceable gauge.

**Table 4. Trouble-Shooting Procedures for the Water Heater (cont'd)**

Symptom	Possible Cause	Remedy
g. Burner fails to ignite or delayed.	Lack of fuel.	Fill fuel tank.
	Fuel lines clogged.	Clear fuel lines.
	Clogged fuel nozzle.	Clean or replace nozzle.
	Water in fuel.	Remove.
	Electrode burned.	Clean electrodes.
	Electrodes out of adjustment.	Adjust electrodes.
	Transformer broken.	Install serviceable transformer.
	Transformer to burner cable assembly disconnected.	Connect cable.
	Transformer to burner cable assembly disconnected.	Install new cable.
	Broken or cracked electrode porcelain.	Replace electrode.
h. Flame failure during firing cycle.	Lack of fuel.	Fill fuel tank.
	Fuel lines clogged.	Clear fuel lines.
	Clogged fuel nozzle.	Clean or replace nozzle.

Table 4. Trouble-Shooting Procedures for the Water Heater (cont'd)

Symptom	Possible Cause	Remedy
h. Flame failure during firing cycle (cont'd).	UV scanner dirty.	Clean face of scanner.
	UV scanner tube clogged.	Clean scanner tube.
	Defective flame safeguard control.	Replace with new control.
	Defective UV scanner.	Replace scanner.
i. Blower motor overload continues to trip.	Fuel pump or motor is bound.	Replace.
j. Smoky fire.	Plugged nozzle.	Clean or replace.
k. Water pump fails to deliver water.	Out of water.	Replace.
	Valves closed.	Open.
	Not primed.	Prime.
	Incorrect rotation.	Reverse any two power lines.
	Air leak on suction side.	Correct.
l. Water pump leaks around drive shaft.	Defective seal.	Replace.

**SECTION IV**  
**GREASE TRAP**

## OVERVIEW

This section of the training manual provides instructions for assembly and operation of a grease trap. Its principal function is to trap grease which drains from sinks in the sanitation shelter and to filter the waste water before discharging into a water receptacle. The grease trap is simply a wooden box with compartmental dividers which form a filter system that is set up into the ground. An electrical sump pump, in the discharge end of the grease trap, regulates the water level in the trap and pumps water through a discharge hose.

Once the sump pump and liquid level control float switch are properly installed and switched "ON," they should operate automatically. A submersible heater can be used during cold weather operation to maintain water temperature to avoid freezing.

## TRAINING OBJECTIVES

The trainee must be able to demonstrate the capability to:

1. Choose a suitable site for location of grease trap. (A suitable site is defined in terms of distance from sinks, power source, elevation and discharge receptacle, as outlined in the Manual.)
2. Dig a suitable hole for grease trap.
3. Identify components of the grease trap and assemble using hammer and nails.
4. Set up sump pump, float switch and control box.
5. Connect water hoses and electrical lead to heater.
6. Test water flow into grease trap and check that trap operates automatically.
7. Take corrective action in the event of system failure.
8. Maintain grease trap routinely to avoid excessive grease build-up.
9. Describe removal of pump and heater and preparation of equipment for storage.

## SPECIAL CONSIDERATIONS

- The grease trap must be located within 9-1/2 feet of the sinks in the Sanitation Shelter, (because this is the maximum reach of the drain assembly), and located below the sink drain hose level.
- Daily cleaning of the grease trap, by skimming the grease from the surface of the water, will avoid damage to the sump pump and insure smooth operation.

## EQUIPMENT AND SPACE REQUIREMENTS

1. Grease trap assembly package (includes nails).
2. Sump pump and discharge assembly.
3. Liquid-level control (float switch) and submersible heater.
4. Control box and electrical leads to power source.
5. Drain and discharge water hoses.

In addition to these items, which are included in the kit, you will need:

1. a shovel;
2. a hammer;
3. a adjustable pipe wrench.

## A. LOCATING THE GREASE TRAP

**NOTE:** The location of the grease trap in relation to the kitchen sinks is important. Therefore, these rules for locating the grease trap should be followed carefully. Assembly operations will require two persons working as a pair.

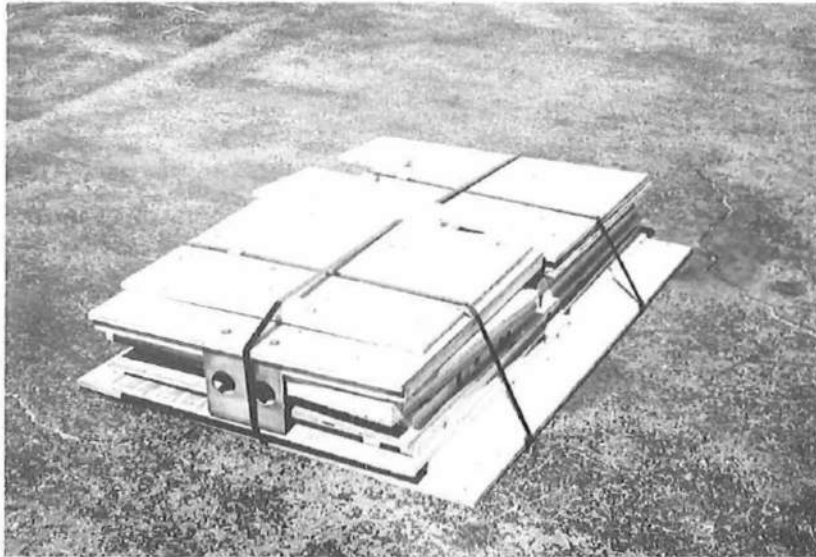
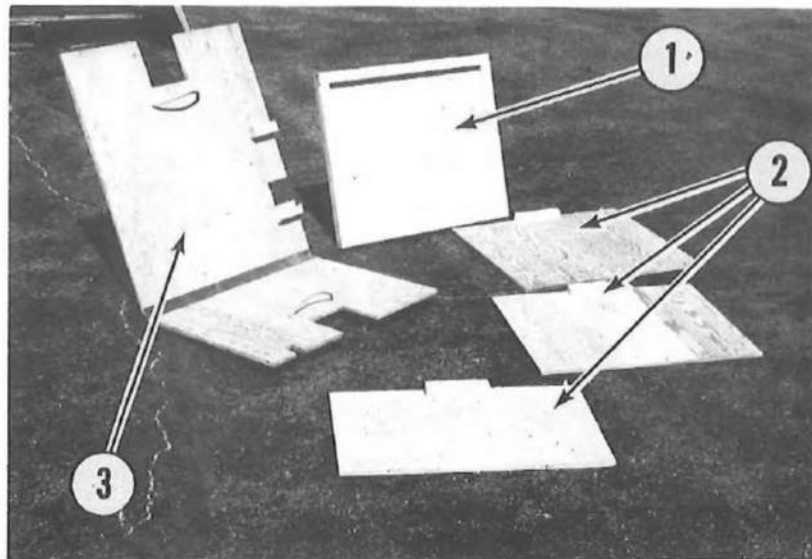

**Figure 78. Grease Trap Packaged Prior to Assembly**

1. Choose a relatively level area near to the end wall of the Sanitation Shelter where the sinks are to be located. Select a site for the grease trap hole which is:
  - less than 9-1/2 feet from the sink drains;
  - less than 25 feet from the power source;
  - below level of sink drain hose.
2. Dig a hole for the grease trap that measures approximately 4 feet wide by 5 feet long and 2 feet deep. Exact dimensions of the grease trap are 3-1/2' x 4-3/4 x 2'.

## B. GREASE TRAP ASSEMBLY

1. Locate the package of wooden pieces for grease trap assembly. Use wire snips to cut the (wire) strapping which holds the package together. Then, lay out the component parts.



- |                      |            |
|----------------------|------------|
| 1. Sump Pump Panel   | 2. Baffles |
| 3. Grease Trap Cover |            |

**Figure 79. Unassembled Grease Trap**

2. Identify the interior wooden pieces of the grease trap. Set the sump pump panel, baffles #1, #2, and #3 and the grease trap cover to one side.

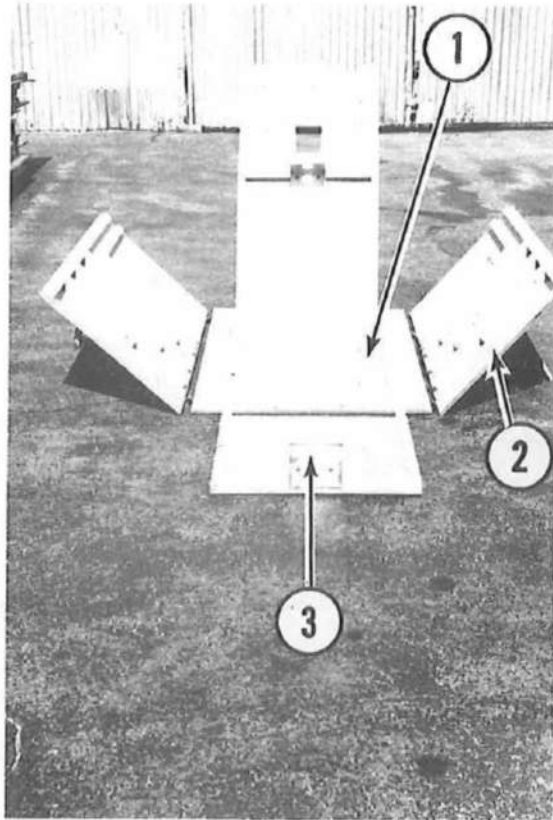

- 1. Bottom Panel
- 2. Side Panels
- 3. End Panels

**Figure 80. Preparing Grease Trap for Assembly**

3. Prepare to assemble grease trap by arranging exterior wooden pieces in their proper positions corresponding to the layout shown above.

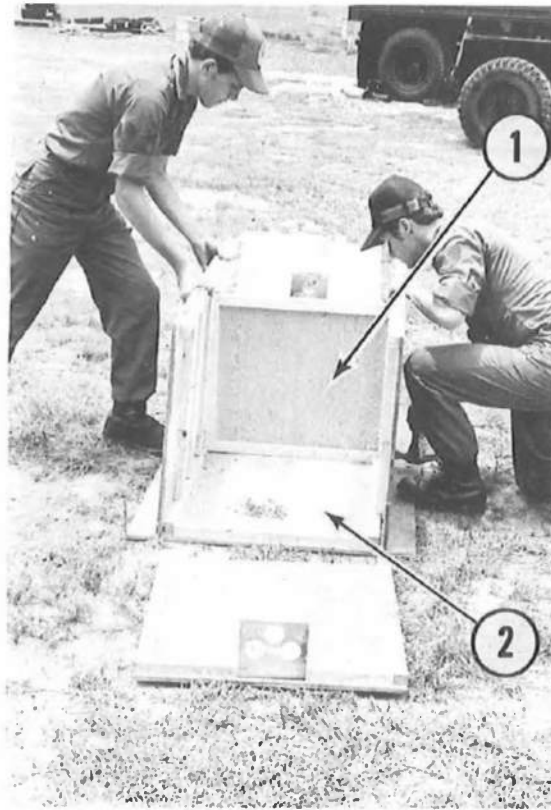

1. Sump Pump Panel      2. Bottom Panel

**Figure 81. Workers Assembling Sump Pump Panels**

4. To assemble the grease trap, position the sump pump panel into its seat in the bottom panel. Then position the right and left side panels, making certain that each fits tightly up against the sump pump panel and sits flush with the bottom panel. While one person holds these pieces in position, the other drives nails into indentations marked along the exterior bottom edge of the side panels. Also, drive a few nails through the side panels into the sump pump panel to secure them firmly in place.

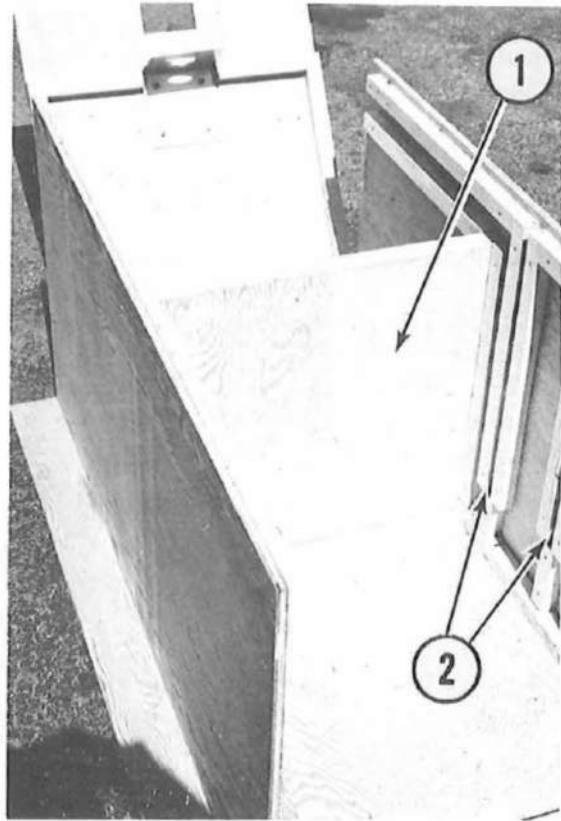

1. Sump Pump Panel

2. Baffle Slide Guides

**Figure 82. Proper Positioning of Side and Sump Pump Panels**

5. Notice in the picture above how the sump pump panel fits tightly into the side panels but does not slide down into position like the baffles.

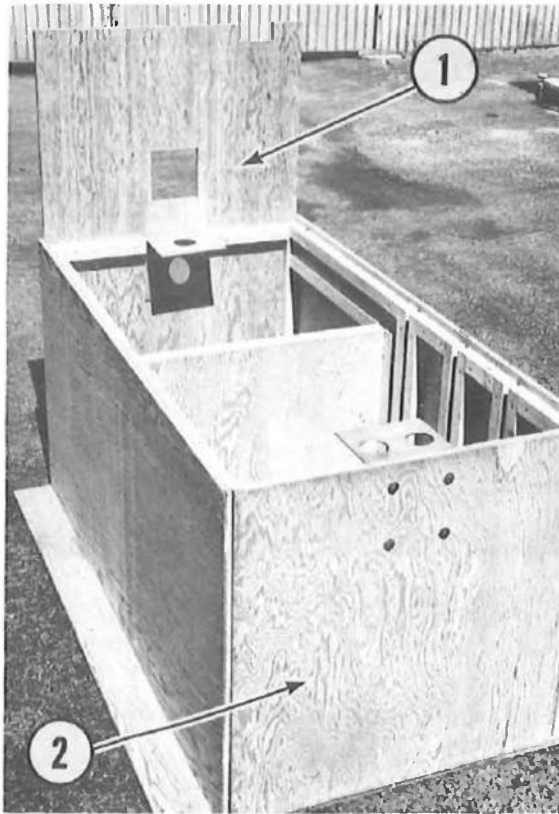

1. Discharge End Panel

2. Drain End Panel

**Figure 83. Assembled End Panels**

6. Position the discharge end panel snugly against the side panels and nail along its edge, making certain that it is flush with the bottom panel.

7. Position the drain end panel snugly against the side panels and nail it into place flush with the bottom panel.

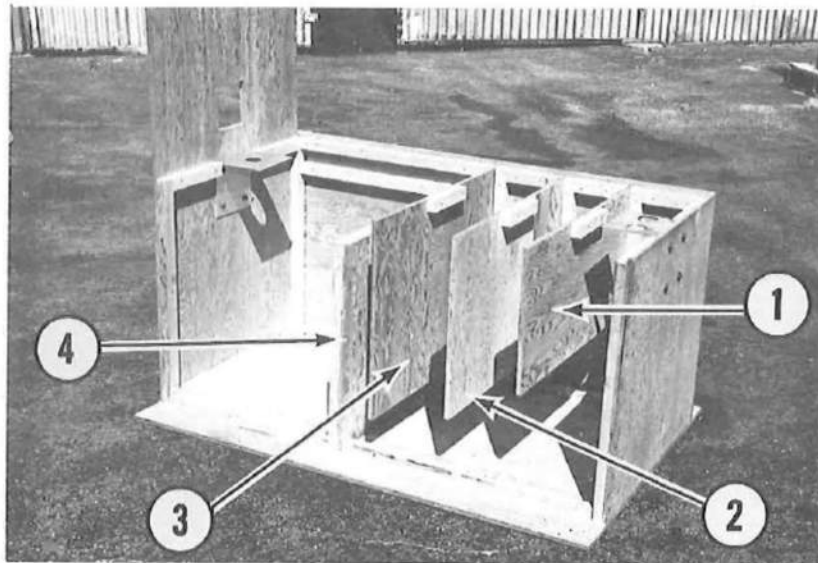

- |              |                    |
|--------------|--------------------|
| 1. Baffle #1 | 2. Baffle #2       |
| 3. Baffle #3 | 4. Sump Pump Panel |

**Figure 84. Correct Placement of Baffles**

8. Use the cut-away illustration above as a guide to identify the relative sizes of baffles #1, #2 and #3 and their correct placement inside the grease trap. Select the shortest baffle (#1) and insert it into position forming a compartment for water draining from the sinks into the grease trap.

9. Select baffle #2 and insert into place then select baffle #3 and insert it into place.

10. Lift the assembled grease trap, one person taking each side of the wooden box, and gently lower it into the pre-dug hole. Place the grease trap cover over the top of the trap. Fill in dirt around the sides of the trap to insure firm installation. Be very careful that you do not spill any dirt inside the grease trap, which could clog and damage the sump pump.

## C. INSTALLATION

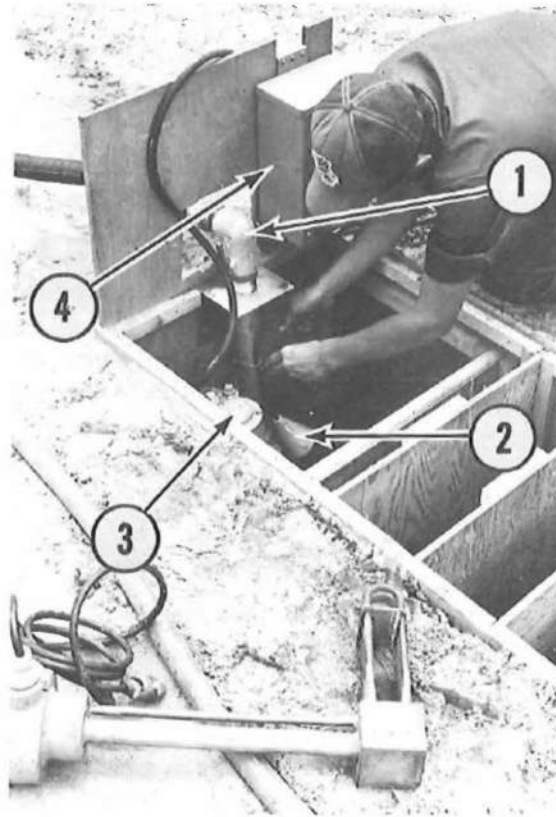

1. Discharge Pipe  
3. Sump Pump

2. Float Switch  
4. Control Box

**Figure 85. Installation of Discharge Pipe, Float Switch, Sump Pump, and Control Box**

1. Remove the cover by pulling up with one hand on each of the rope-handle loops.
2. Locate the sump pump and place it into its compartment nearest to the discharge end panel. Insert discharge pipe through the "window" in the wooden discharge end panel, through the metal angle-bracket, and connect to the threaded discharge flange of the pump.
3. Set up the metal control box on the notch "cut-out" of the discharge end panel. The actual electrical wiring of the control box and pump to a main power source should be done by a qualified electrician.
4. Tie the float switch to the discharge pipe so that it activates the sump pump when the waste water level reaches the maximum capacity of the grease trap.

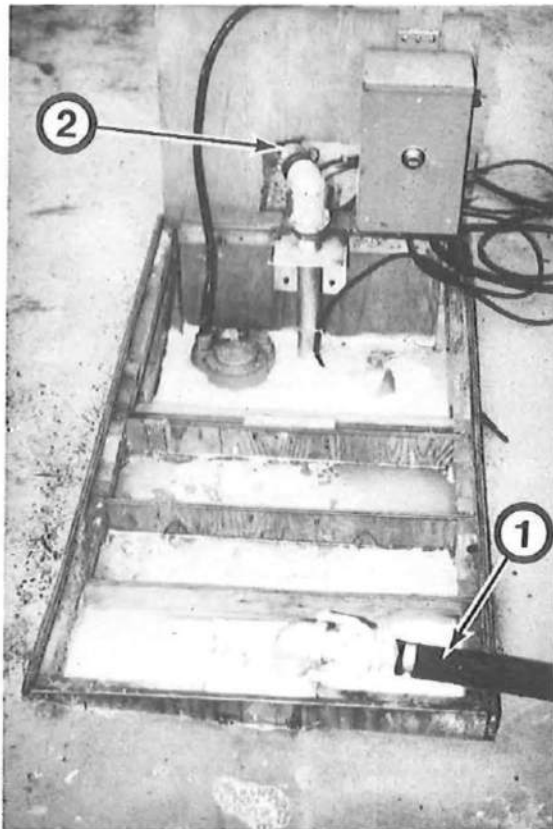

1. Drain Hose      2. Discharge Hose

**Figure 86. Drain and Discharge Hoses**

5. Locate the drain hose attached to the sanitation sinks QD coupling underneath the sink drain.

6. Insert the grease trap end of the drain hose through the metal angle bracket on the drain end panel. Allow about 6"–9" of hose to extend down into the first compartment of the grease trap.

7. Locate the discharge hose and attach its QD coupling to the fitting on the discharge pipe extending above ground and beyond the discharge end panel. The discharge hose leads the filtered waste water to a disposal receptacle.

8. Insure that an electrician has wired the control box and sump pump to a power source. Switch the sump pump switch to the **AUTO** position (for automatic operation).

9. Check for proper pump motor rotation:

- a. disconnect the OD coupling of the discharge hose;
- b. partially fill the sump compartment with water until the "float switch" activates the sump pump;
- c. check to see that the pump is pushing water out the discharge pipe.

If no water is being discharged, then the pump's 3-phase motor rotation must be reversed by changing the electrical wiring at the control box or main generator panel. A qualified electrician should be called to do this.

If the water flows freely out the discharge pipe, reconnect the discharge hose OD coupling. The grease trap is now ready for automatic operation.

10. Briefly turn on cold water faucet at sink in Sanitation Shelter to check that water drains correctly into grease trap.

11. Replace grease trap cover.

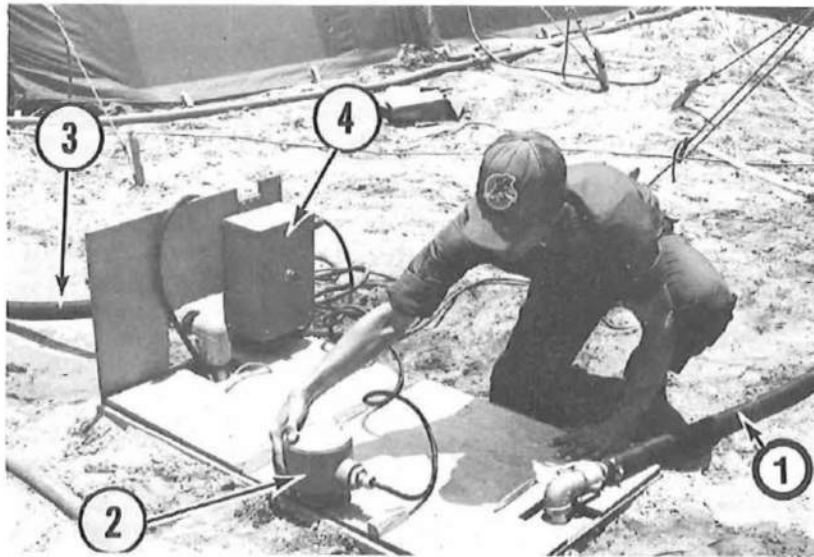

- |                   |                       |
|-------------------|-----------------------|
| 1. Drain Hose     | 2. Submersible Heater |
| 3. Discharge Hose | 4. Control Box        |

**Figure 87. Submersible Heater Installed**

12. Install submersible heater (if required by cold weather conditions) by placing the lower section (heating coils) below the grease trap cover and the upper section (temperature gauge) above the cover.

13. Plug the electrical lead from submersible heater into the side of the control box. The heater will operate automatically to maintain water temperature in the grease trap.

## D. OPERATION

1. Check to see that the sump pump switch is in the "AUTO" position. The three-way switch has positions marked "AUTO," "OFF," and "MANUAL." When properly set up, the grease trap will operate automatically to filter and discharge the waste water from the field kitchen sinks.

2. Daily remove the grease trap cover and check on the state of greasy water in trap. Skim off excess grease and dispose of the grease in an approved manner.

3. Routinely clean the exterior of the sump pump and submersible heater to insure their smooth operation.

4. If the sump pump becomes clogged, the pump reset button will "lock out" and shut down the pump. First correct the problem and then depress the reset button to restart the pump's automatic operation.

## E. TROUBLE-SHOOTING PROCEDURES

Table 5. Trouble-Shooting Procedures for the Grease Trap Assembly

Symptom	Probable Cause	Corrective Action
1. Water puddle over grease trap	● Recent rainstorm	● None
	● Power failure	● Check leads into power source
		● Check control panel circuit breaker. If again it pops out, call an electrician.
	● Clogged sump pump	● Remove sump pump; clean (or replace)
	● Blocked discharge hose	● Check end for blockage-- disconnect and flush
2. Drain back-up in sink	● Blocked drain hose	● Disconnect and flush

**SECTION V**

**REMOTE TANK BURNER SYSTEM**

## OVERVIEW

You are probably familiar with the operation of the M-2A Gasoline Burner. The remote tank burner unit that you will be using with the New Harvest Eagle Field Kitchen is similar to the M-2 burner in almost all respects but one: The remote tank burner unit does not have a built-in gasoline tank. It does not, therefore, require manual refilling or pressurizing, as is normal with the M-2A Burner Unit. Because the remote tank burner is connected, via a service fuel line, to a remote pressurized fuel supply, it is automatically filled and pressurized upon connection and can remain in operation for long periods of time. As with all gasoline burning units, it must be carefully watched while it is in operation.

This section of the training manual provides instructions in layout of the remote tank burner system, and in lighting and maintaining burner units.

## TRAINING OBJECTIVES

The trainee will be able to demonstrate a capability to:

1. Lay out and assemble a remote tank burner system.
2. Fill and light a gasoline torch.
3. Use the gasoline torch to light the burner unit preheater.
4. Light the preheater.
5. Light the burner.
6. Shut down, disconnect and remove a burner unit from a kitchen appliance for preventive maintenance.
7. Shut down burner system at end of day.

## SPECIAL CONSIDERATIONS

Pressurized gasoline is being used in the remote tank burner system. When quick disconnect (QD) fittings on the fuel lines are connected or disconnected—such as when a burner unit is being installed, or removed for maintenance purposes—pressurized gasoline may drip out of the fitting. If a flame is close by, caution must be exercised to avoid possible fires.

## SYSTEM COMPONENTS

1. Tankless burner units.
2. Main fuel supply tanks.
3. Air compressor.

4. Fuel and air lines.
5. Gasoline torch.
6. Matches (or a cigarette lighter).\*
7. Fire extinguisher.

\*No one should be smoking during this training session.

## A. SETTING UP FUEL TANKS AND AIR TANK

Pressurized gasoline that is burned in the burners comes via service fuel lines from a 60-gallon fuel tank which is maintained at a pressure of 12 p.s.i. from a single air supply tank.

Before laying out and assembling the remote pressurized fuel supply system, select a fuel tank site that is at least 50 feet from the kitchen shelter, is relatively level, and is free of large obstructions such as trees and boulders. The site should also be away from paths of heavy foot traffic. If at all possible, the site should be accessible to fuel delivery vehicles to permit direct filling of fuel tanks.

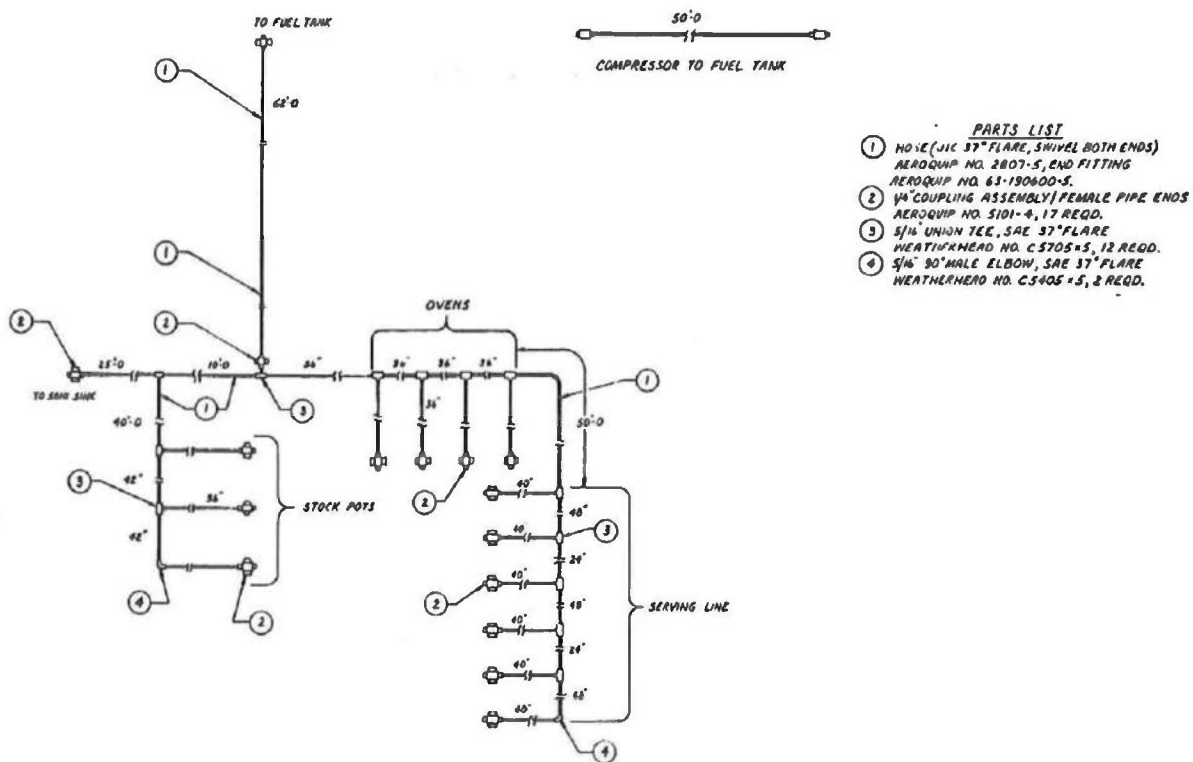
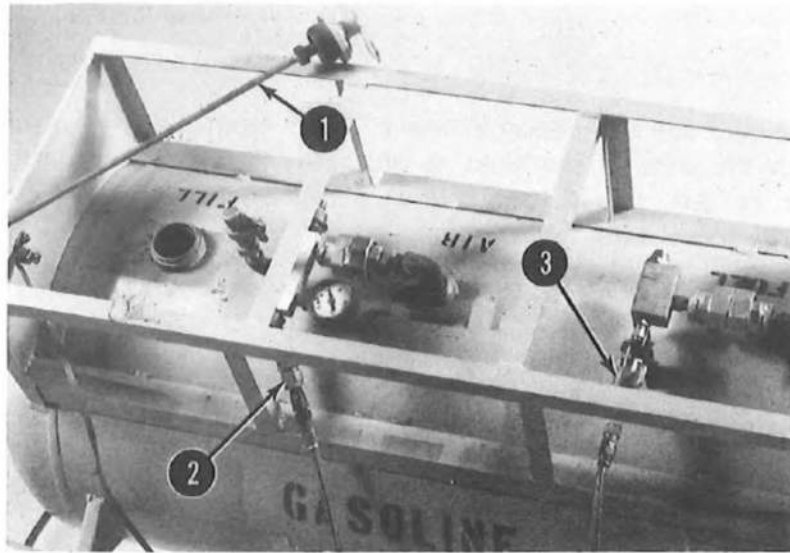

Figure 88. Fuel Line Layout

Each fuel tank is fitted with:

- (i) a screw cap with dip stick;
- (ii) a valve/connector attachment to which an air hose from the air tank will be connected;
- (iii) a valve/connector attachment to which a service fuel line to the burners in the kitchen appliances and to the service table will be connected.



1. Filler Cap and Dip Stick

2. Air Hose Connector

3. Fuel Service Line Connector

Figure 89. Main Fuel Tank

The air hose valve/connector is the attachment in the center of the tank. The filler cap and the line valve/connector are at either end.

4. Pressure Relief Safety Valve
5. Air Pressure Gauge
6. Flame Arrestor
7. Excess Flow Control Valve

The air compressor, mounted on the top of the air tank, is driven by a 110 volt, single cycle electric motor. The compressor will maintain a pressure of 70–150 p.s.i. in the air tank. Alternatively, the air tank may be charged to a pressure of 70–150 p.s.i. from an external compressor, through a valve (resembling the valve on an automobile tire) on the valve/connector attachment at the end of the tank.

#### Procedure

1. Place the two fuel tanks approximately 50 feet from the kitchen shelter and at least 20 feet apart with the ends of the tanks at which the filler caps are located closest to the access road. The air tank should be placed in a spot that is sheltered from the rain but readily accessible to the electric power source.

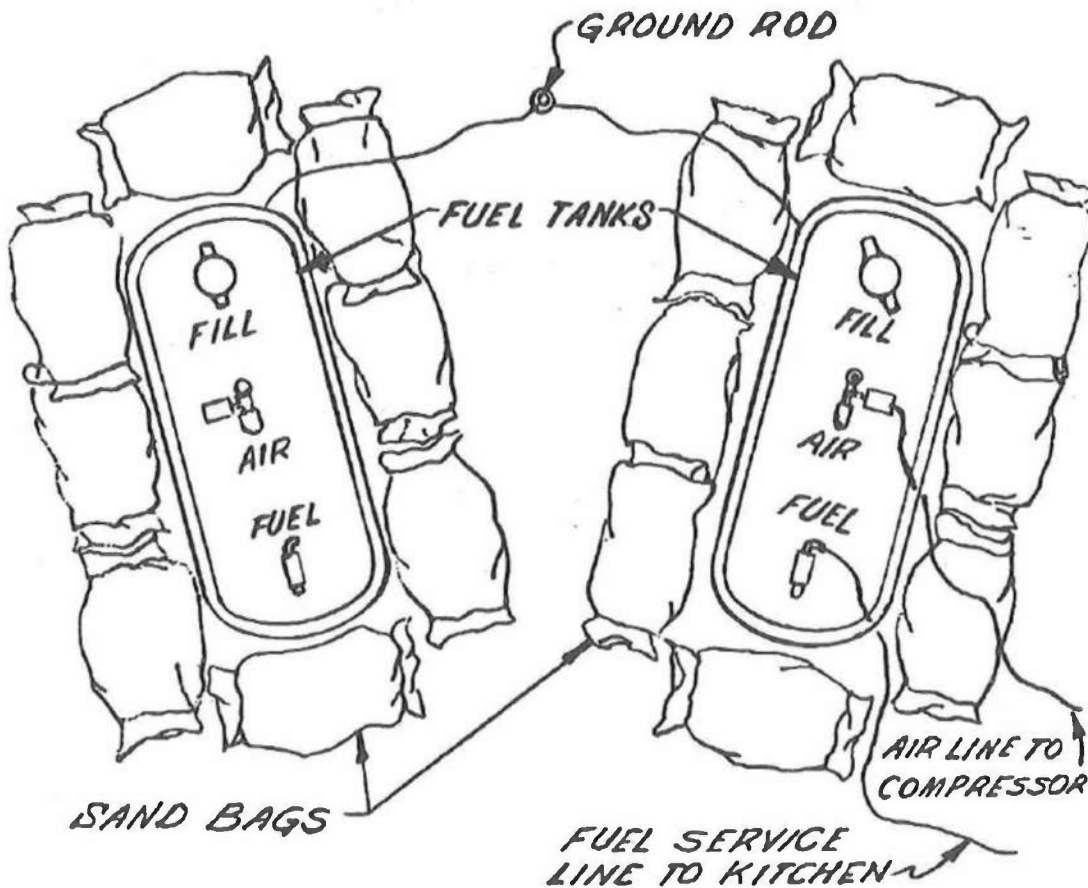

Figure 90. Sandbags Positioned to Protect Fuel Tanks

2. Connect an air line from the air tank to the QD fitting on one of the two fuel tanks. Pressurize the fuel tank to 12 p.s.i. before going on to the next step.

**NOTE:** The pressure regulator assembly on this air tank will automatically maintain this pressure.

3. Drive a grounding rod into the ground between the tanks. Connect the grounding wires to the grounding rod and the grounding lug of the tank.

4. Lay out the main service fuel lines in accordance with Figure 88.

5. Install a burner unit in each kitchen appliance that requires a burner (See "Installing the Burner Unit").

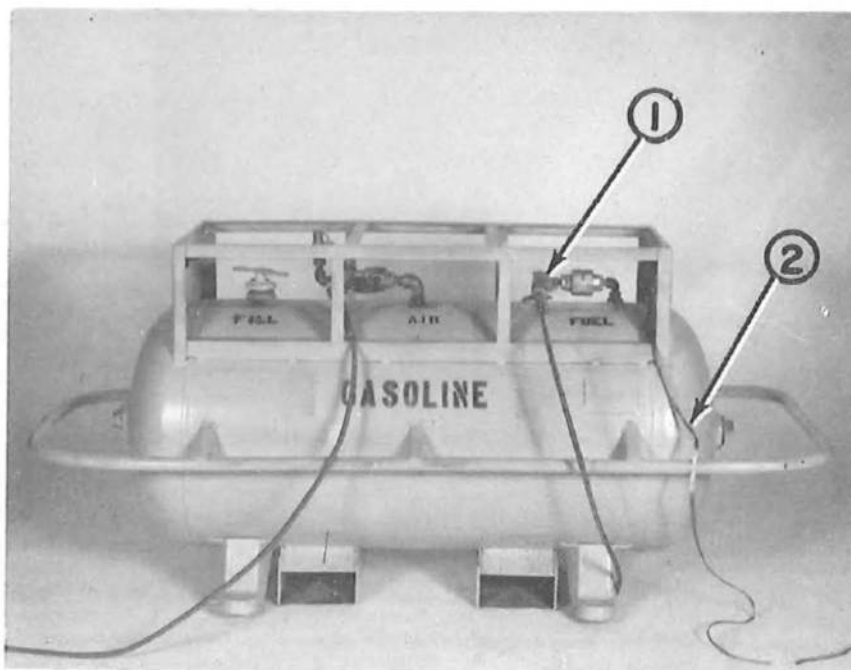

1. Fuel Line with Quick Disconnect Fitting      2. Ground Wire

**Figure 91. Fuel Service Line Connected to Fuel Quick Disconnect Fitting**

6. Connect the main service fuel line to the fuel QD fitting on the fuel tank.

**NOTE:** Because there is a danger of pressurized gasoline dripping from a QD fitting when it is being connected, be sure that all burner units are installed and that they are connected, via the pig-tails of the main service fuel line before you connect the main service fuel line to the fuel tank. This precaution will keep pressurized gasoline out of the fuel lines until after all QD fittings on burner units are connected.

## B. LIGHTING THE GASOLINE TORCH

**CAUTION:** DO NOT LIGHT THE GASOLINE TORCH IN EITHER THE KITCHEN SHELTER, THE STORAGE SHELTER OR THE DINING SHELTER. LIGHT IT ONLY OUTSIDE. BE SURE THAT AN ATTENDANT WITH A 15-LB CO<sub>2</sub> FIRE EXTINGUISHER IS PRESENT IN THE IMMEDIATE AREA WHILE YOU ARE LIGHTING THE TORCH.

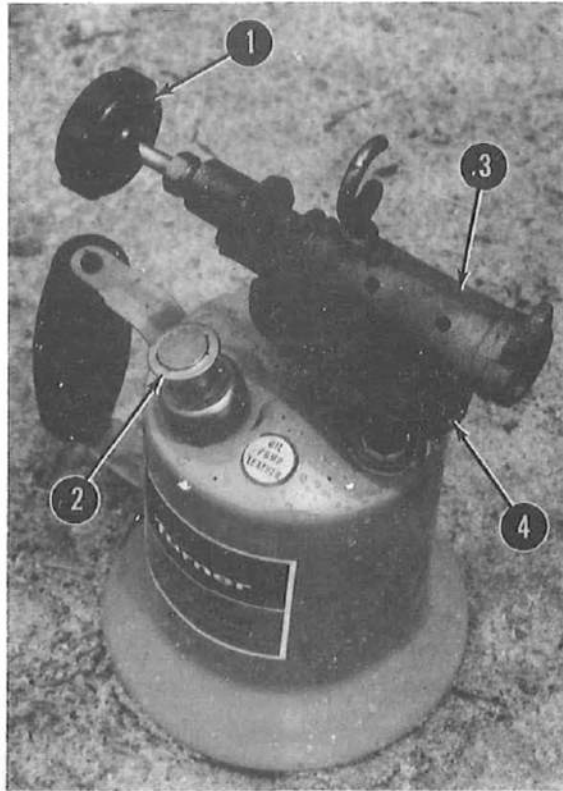

- |                      |                  |
|----------------------|------------------|
| 1. Needle Valve Knob | 2. Air Pump      |
| 3. Torch Barrel      | 4. Generator Cup |

**Figure 92. Gasoline Torch**

1. Check that the needle valve is closed by gently turning the needle valve knob clockwise.

**NOTE:** Needle valves must be seated softly and gently during closing. Needle valves may be damaged if closed too tightly.

2. Unscrew and remove the air pump and fill the tank approximately 3/4 full with clean gasoline. Replace the air pump.

3. Pump 10–15 strokes of air into the tank. This will pressurize the tank and force gasoline up to the needle valve.

4. Place a piece of cardboard (such as the end flap off a corrugated carton) against the end of the barrel of the torch, and open the needle valve by slowly turning the knob counterclockwise two or three turns.

A thin stream of gasoline will strike the cardboard and will then be seen to trickle down through a hole in the barrel into the generator cup.

5. Allow the generator cup to fill 3/4 full with gasoline before closing the needle valve.

6. **Caution.** Wipe up any gasoline that may have spilled over the brim of the cup. Remove the cardboard soaked with gasoline from the area.

7. Light the gasoline in the generator cup with a match or lighter. As the gasoline burns, the flames heat the barrel of the torch. To be sure that most of the heat from the flames is indeed directed onto the barrel, shield the torch from the wind while the gasoline is burning.

When all of the gasoline in the generator cup has burned, the barrel of the torch should be hot enough to vaporize gasoline in the barrel channels.

8. Apply a lighted match (or a cigarette lighter) to the end of the barrel, and open the needle valve by slowly turning the knob counterclockwise two or three times.

An intense blue flame should come from the end of the barrel. (In bright sunlight the flame will be hard to see, but you will hear the characteristic low roar of a gasoline torch.)

**NOTE:** If you get a yellow flame (instead of a blue flame) when you open the needle valve, the barrel has not been heated sufficiently to vaporize the gasoline properly. Close the needle valve to shut off the flame and let cool and repeat steps 4 through 8.

9. Pump 20–25 additional strokes of air into the tank to intensify the flame. As gasoline in the tank is used, you will need to pump additional strokes of air in order to maintain the proper flame intensity.

### C. INSTALLING THE BURNER UNIT

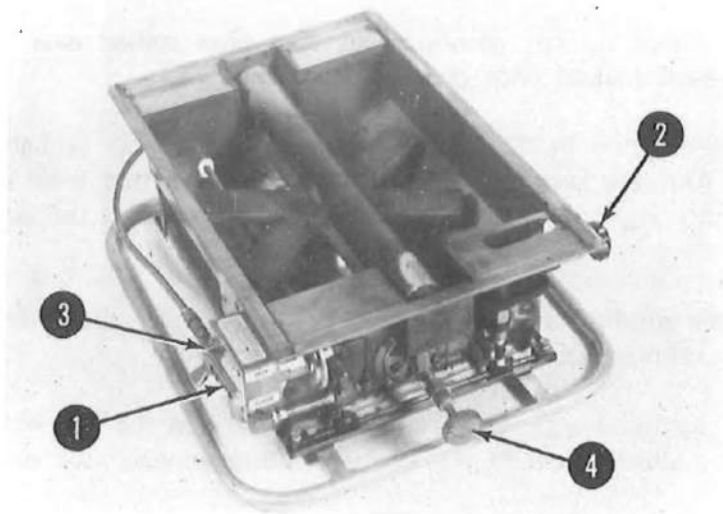

- |                             |                    |
|-----------------------------|--------------------|
| 1. Safety Shut Off Valve    | 2. Preheater Valve |
| 3. Quick Disconnect Fitting | 4. Flame Valve     |

Figure 93. The Burner Unit

1. Place the burner unit in the kitchen appliance.
2. The safety valve will be in the closed position, with the handle pointing down.
3. Engage the OD at the end of the nearest pig-tail attached to the main service fuel line with the QD at the end of the burner safety valve, attached to the left hand side of the burner unit.

**CAUTION:** MAKE SURE THAT YOU HOLD BOTH QD FITTINGS SO THAT THEY ARE ALIGNED WHEN YOU MAKE THIS CONNECTION. IF AN OPEN FLAME IS NEARBY, ANY GASOLINE DRIP MAY IGNITE. IF GASOLINE HAS SOAKED INTO YOUR CLOTHING, YOU MAY BE SEVERELY BURNED.

#### D. OPENING THE SAFETY VALVE

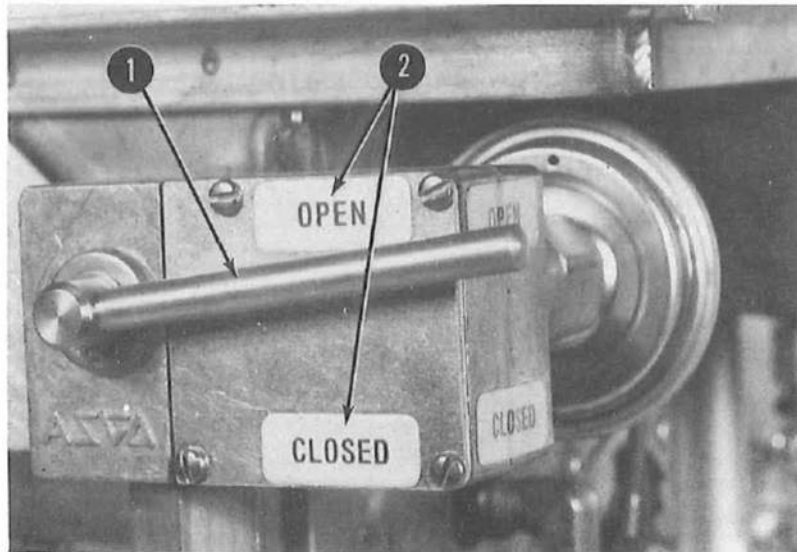

1. Safety Valve Handle      2. Open/Close Decals

**Figure 94. The Safety Valve in Open Position**

1. Open safety valve by pulling handle up to open position; hold open until pressure operates automatic mechanism to hold handle in open position (1 to 5 seconds).

**NOTE:** Safety valve will automatically close if line pressure drops below 5 p.s.i.; above procedure will be required to restart burner.

## E. LIGHTING THE PREHEATER

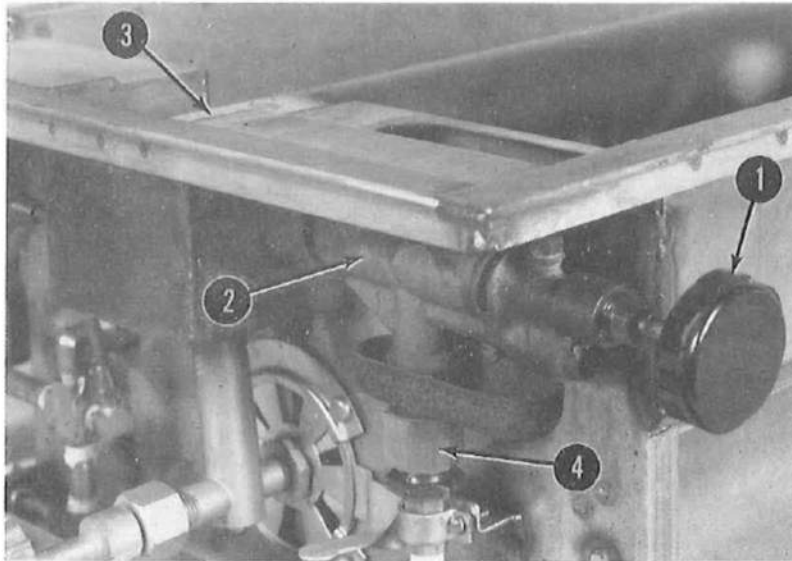

- |                                |                     |
|--------------------------------|---------------------|
| 1. Preheater Needle Valve Knob | 2. Preheater Barrel |
| 3. Generator                   | 4. Packing Nut      |

Figure 95. Burner Unit Showing Preheater Components

1. Pull the burner unit out from its position in the kitchen appliance approximately 6 inches.

2. Check to insure that both the preheater needle valve and the flame control valve are closed by gently turning the needle valve knobs clockwise. Take care not to close the valves too tightly.

3. Open the safety valve. Pressurized gasoline will flow up to the torch needle valve.

4. Pass the flame of the gasoline torch back and forth along the preheater barrel for a minimum of 60 seconds.

After approximately 60 seconds (it may be longer in cold weather), the barrel of the preheater should be hot enough to vaporize gasoline in the barrel channels.

5. Play the flame of the gasoline torch on the end of the preheater barrel closer to the generator, and open the preheater needle valve by slowly turning the knob counterclockwise two or three turns.

**CAUTION:** A whisp of vapor coming from the end of the preheater closer to the needle valve knob is an indication that the packing unit is loose. Use a 1/2" wrench to tighten the packing nut so that no vapor escapes.

When the preheater is properly lit it will give off the characteristic low roar of a gasoline torch. In addition, an intense blue flame will come from the end of the preheater barrel. However, if the room lighting is bright, this flame will be hard to see.

**NOTE:** If you get a yellow flame (instead of a blue flame) when you open the needle valve, the barrel has not been heated sufficiently to vaporize the gasoline properly. Close the needle valve to shut off the flame and repeat steps 4 and 5.

## F. LIGHTING THE BURNER HEAD

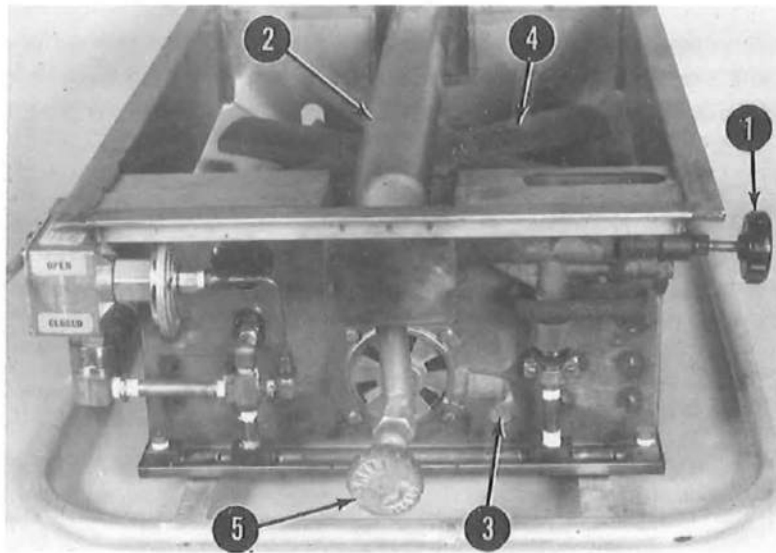

- |                             |                |
|-----------------------------|----------------|
| 1. Preheater                | 2. Generator   |
| 3. Air Shutter Valve Handle | 4. Burner Head |
| 5. Flame Valve Handle       |                |

Figure 96. The Burner Unit Showing Generator and Burner Head

1. Allow the blue flame of the preheater to strike the end of the generator for approximately 4–5 minutes, after which time the generator end should be glowing with a cherry red color.

2. Set the air shutter to the half-open position.

3. Hold the flame of the gasoline torch above the burner head. (It might be necessary in cold weather to move the flame along the burner head two or three times to preheat it slightly before beginning the next step.)

4. Open the flame control valve by turning the knob, slowly, counterclockwise about half to one and a half turns. Gasoline vapor will flow from the generator into the burner head, mixing with air on the way. The gasoline vapor/air mixture escapes through the slots on the burner head and is lit by the gasoline torch flame.

**CAUTION:** The mist that may be seen coming out of the burner heads is the gasoline vapor you are trying to light. This is a flammable vapor. Do not allow too much to accumulate before being lit.

5. Use the flame control valve and the air shutter to adjust the flame at the burner head. You should get a sea-green colored flame. The flame may, however, be slightly yellow at first. Allow it to burn for 5–10 minutes and then re-adjust the flame control valve and the air shutter to get a blue-green colored flame.

**NOTE:** Opening or closing the flame control valve varies the height of the flame, but it also varies the gasoline vapor/air mixture. In order to maintain the correct gasoline vapor/air ratio (indicated by the blue-green color of the flame), you will need to adjust the air shutter each time you open or close the flame control valve.

**CAUTION:** A flaring yellow flame means that raw fuel is being burned. If this occurs, close the flame control valve and begin the lighting procedure again.

6. Close the preheater needle valve after the flame stabilized by gently turning the valve knob clockwise. This will shut off the flame of the preheater.

## G. EXTINGUISHING AND REMOVING THE BURNER UNIT

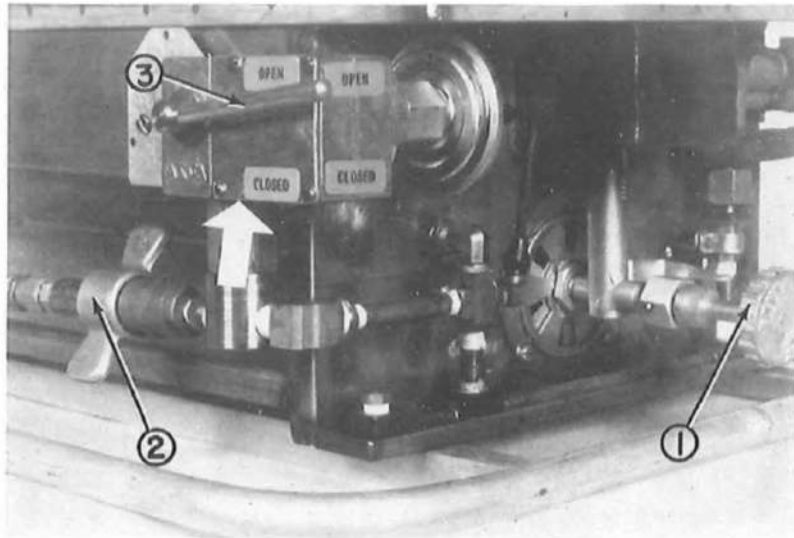

1. Flame Valve Knob
2. Quick Disconnect Fitting
3. Safety Valve

**Figure 97. Burner Unit Showing Disconnect Safety Valve**

1. Close the flame control valve by gently turning the knob clockwise. Remember—needle valves can be damaged if closed too tightly.

2. After the flame is out, disconnect the QD fitting at the end of the main service fuel line pig-tail from the QD fitting at the end of the burner safety valve.

**CAUTION: MAKE SURE THAT YOU KEEP THE TWO QD FITTINGS ALIGNED AS YOU DISCONNECT THEM.**

3. Remove the burner unit from the appliance.

**NOTE:** Only remove a burner unit if it requires maintenance work or is to be replaced by another unit.

#### **H. SHUTDOWN OF BURNER SYSTEM AT END OF DAY**

1. Check all burners and make sure that all flame valves are turned off.
2. Turn off air compressor motor using electric switch after the supply tank has been filled to its maximum pressure.
3. Disconnect air hose from fuel tank using quick disconnect fitting.

**NOTE:** This procedure does not depressurize the fuel tank. Pressure is retained to insure subsequent operation for several hours in the event of power or compressor failure.

4. Disconnect fuel service line from fuel tank using quick disconnect fitting. Check to insure that the QD coupling half on the fuel tank is not leaking.

#### **I. START UP OF BURNER SYSTEM AT BEGINNING OF DAY**

1. Check all burners to make sure that all flame valves are off.
2. Connect fuel service line to fuel tank.
3. Connect air hose to fuel tank.
4. Turn on air compressor motor at switch on air compressor.
5. Proceed to light burners, see paragraphs B and C in Section D.



**SECTION VI**  
**SHELTER LIGHTING**

## OVERVIEW

Fluorescent lighting tubes are to be installed in the kitchen shelter, the dining shelter, and the sani/storage/veg prep shelters and come ready-to-use when unpacked. Thus, this section of the training manual simply describes procedures for their installation and operation in the shelters. During the assembly of the kitchen shelter, it is important to remember to install the lighting bars prior to tying the shelter liner in place. Once the lighting bars have been properly installed, the lighting tubes can be suspended from them, connected in series, and connected to the power source through electrical leads. The sani/storage/veg prep shelter has no liner, and lighting installation is simply a matter of positioning the lighting bars and attaching the lighting tubes.

## TRAINING OBJECTIVES

The trainee must be able to demonstrate the capability to:

1. Unpack lighting tubes and position them for installation.
2. Install lighting tubes and adjust suspension straps so that the lighting tubes hang at a level.
3. Connect lighting tubes in series and to a power source and switch each ON or OFF.
4. Disconnect lighting tubes and prepare them for storage.

## SPECIAL CONSIDERATIONS

The fluorescent lighting tubes can be damaged and therefore should be handled carefully. When not in use, they should be safely stored in the case provided.

## EQUIPMENT REQUIREMENTS

Sufficient numbers of lighting tubes (four packed to a case) to be installed: two lighting tubes (one each side) per module of the kitchen shelter. Thus, a five-module kitchen will require 10 tubes. The six tubes for the sani/storage/veg prep shelter will be equally distributed among the three functional areas. One tube will be installed in each eight foot section of the dining shelter.

## A. LIGHTING ASSEMBLY

**NOTE:** The fluorescent lighting tubes are securely packed, four to a case, and come ready-to-use. They should be handled with care to avoid unnecessary shaking which may damage the fluorescent filament. Use only with 120V, 60Hz, electrical current.

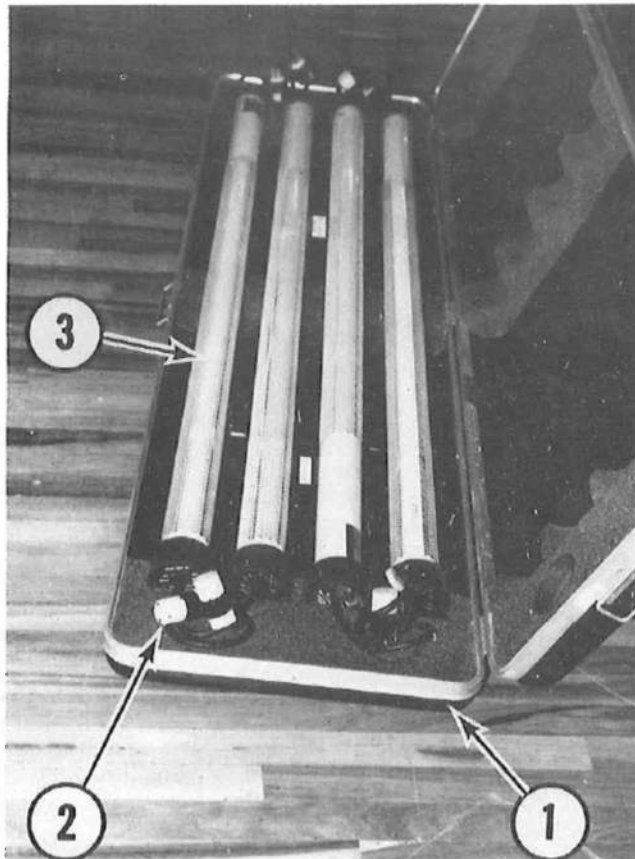

- 1. Hard Plastic Carrying Case
- 2. Electrical Plugs
- 3. Fluorescent Lighting Tube

**Figure 98. Bruce Lighting Assembly**

## B. INSTALLATION

1. Open lighting case and check lighting tubes for breakage or missing electrical outlets.

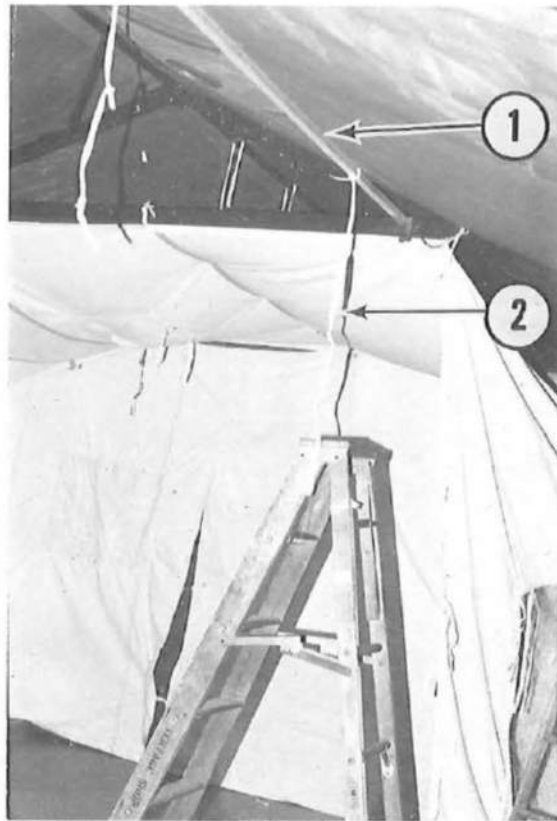

1. Installed Lighting Bar

2. Lighting Support Strap

**Figure 99. Installed Lighting Bar and Support Strap**

2. The lighting bars, from which the fluorescent lighting tubes are suspended should have been installed prior to the installation of the kitchen liner. The procedure for installing and positioning the lighting bars has been described in Section I-H Lighting Bar.



**Figure 100. Lighting Support Strap Pulled Through Kitchen Liner**

3. Lighting support straps attached to each lighting bar should be hanging through small openings in kitchen liner. If the straps are not visible, reach through the openings in the liner and pull the straps through.

4. Take a lighting tube from its case.



**Figure 101. Lighting Tube Installation**

5. While one person holds an end of the fluorescent lighting tube, the other person positions the tube overhead, next to the lighting support strap.

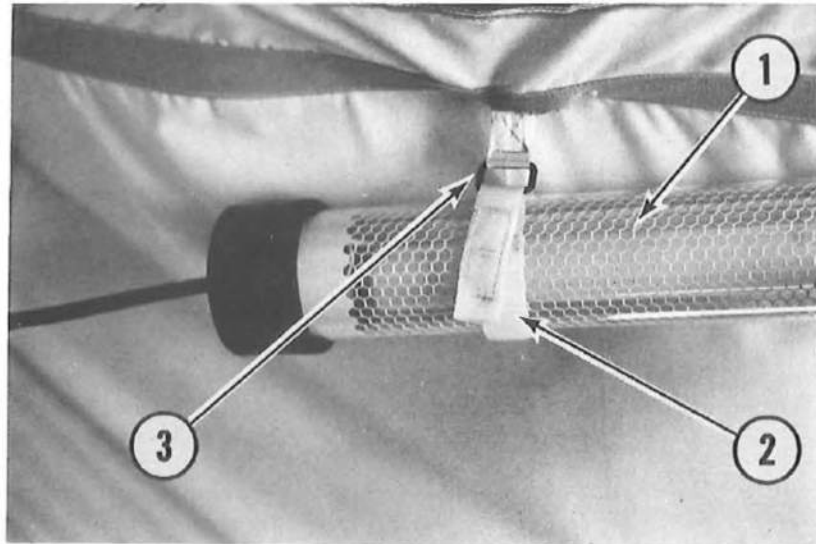

1. Lighting Tube
2. Velcro Patch
3. Buckle on Lighting Support Strap

**Figure 102. Installed Lighting Tube**

6. Wrap lighting support strap once around the body of the lighting tube approximately 6" from the end of the tube and insert the end of the strap through the buckle. Tighten the strap by pulling upwards through the buckle (until the tube is suspended on a level), then press the strap down onto the Velcro patch to "lock" the tube in position.

7. Move under the second lighting strap and repeat procedures in Step 6. The first lighting tube should now hang free and level below the kitchen liner.

8. Before installing the next lighting tube, check to be sure that the electrical plug from the last tube will reach to connect with this next tube to be installed. These lighting tubes will work in series.

9. Install the next lighting tube using the methods described in Steps 2-7.

10. Connect an electrical lead from power source to initial lighting tube outlet. Lighting is now ready for use.

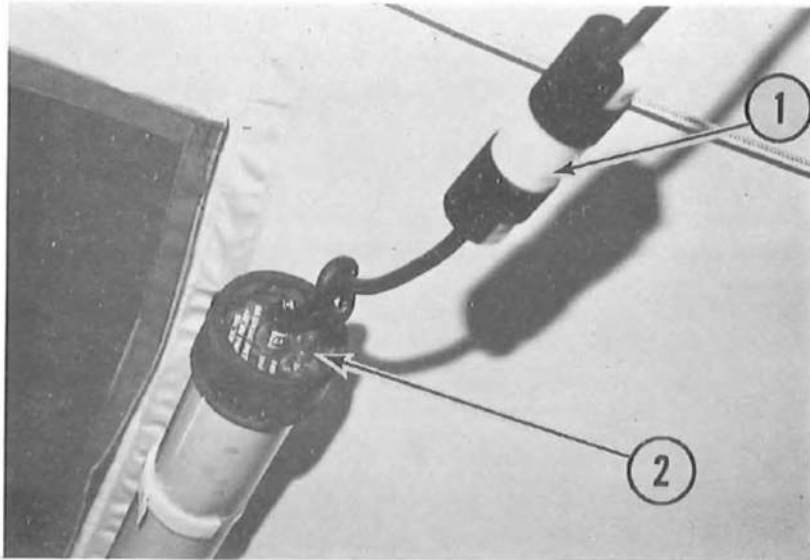

1. Electrical Plugs in Series      2. Individual ON/OFF Switch

**Figure 103. Lighting Tube Connected to Electrical Lead**

11. Check to be certain that the lighting tubes are all connected in series and joined to an electrical lead from the main power source. Once the main power switch is turned **ON**, the series of lights will stay on constantly.

**NOTE:** The lighting tubes may be turned **OFF** as a series simply by switching **OFF** the main power. An individual lighting tube may be turned **OFF** by flipping the **ON/OFF** switch at the extreme end of the tube.

**SECTION VII**  
**PORTABLE SHELTER HEATER 400,000 BTU**

## OVERVIEW

The tent heater is a standard, duct-type, portable 400,000 BTU/HR heater. It is fully enclosed, trailer-mounted, and designed to provide heat for aircraft engines, shelters, or similar enclosed buildings. Heat is provided by blowing warm air through ducts into the areas to be heated. The tent heater itself is strictly an outside piece of equipment. It should never be operated in an enclosed area.

The front of the tent heater has a wire basket for storing the air ducts, and the rear can be identified by the air outlet with the duct adapter assembly. To transmit the warm air from the tent heater to the dining shelter there is a 12" diameter main duct. To distribute warm air inside the shelter complex, there is a 12" duct adapter and three (3) independent 6" diameter air distribution ducts leading from it for directing heat to the desired areas.

A standard Model 1A08-III gasoline engine drives the Model BT400-40-1 Heater (also called a Herman Nelson Heater). A 16-gallon fuel tank is suspended from the underside of the unit and provides fuel to the heater fuel pump and the gasoline engine.

Air is drawn in through the air inlet door (near basket), passes through and around a heat exchanger, and then is discharged through a 12" main air duct (mounted on the duct adapter assembly) to the shelter complex and is directed inside the shelter complex by 6" distribution ducts.

As a safety precaution, **do not** operate the tent heater in enclosed areas or areas lacking adequate ventilation to support heater fuel combustion. Never operate this heater inside a NHE shelter.

Remove the air outlet cover from the air discharge end of heater before operating, and remember to open the air inlet door whenever the heater is operating. There is a temperature selector knob, among other controls, which allows the operator to select the desired temperatures of the discharge air ranging from 150°F to 280°F. A heat-sensing element in the heater discharge air stream will activate a fuel control valve when the air temperature exceeds 330°F in order to reduce the flow of fuel to the combustor and thus cool down the heat exchanger.

The tent heater weighs nearly 800 lbs on its trailer. The recommended maximum towing speed of the trailer is 20 mph over smooth paved surfaces and 10 mph over rough terrain.

## TRAINING OBJECTIVES

The trainee must be able to demonstrate a capability to:

1. Set up the tent heater, including the attachment of appropriate air ducts.
2. Start up the heater and describe the operating controls.
3. Adjust temperature and volume of air flow.
4. Shut down the tent heater and prepare it for storage.

## SPECIAL CONSIDERATIONS

- Do not operate heater in areas lacking proper ventilation.
- When filling the fuel tank with gasoline, use care to prevent metal-to-metal contact between fuel container and fuel tank. Do not smoke or use an open flame in the vicinity.
- Never operate heater inside a building.
- A fire extinguisher should be close at hand when the heater is operating.
- Allow the heater to cool down before removing any parts or ducts to avoid burns.

### A. ASSEMBLY



Figure 104. Heater in Position Near Shelter

1. Position the tent heater within 15 feet of the dining shelter. Select a site which is downwind from the shelter so that combustion fumes are not carried into the dining areas.
2. Locate the heater on firm, level ground with the tow bar in a lowered position. Block the wheels to prevent movement during operation.
3. Unpack the 12" and 6" air ducts stored in the front basket and alongside the heater.

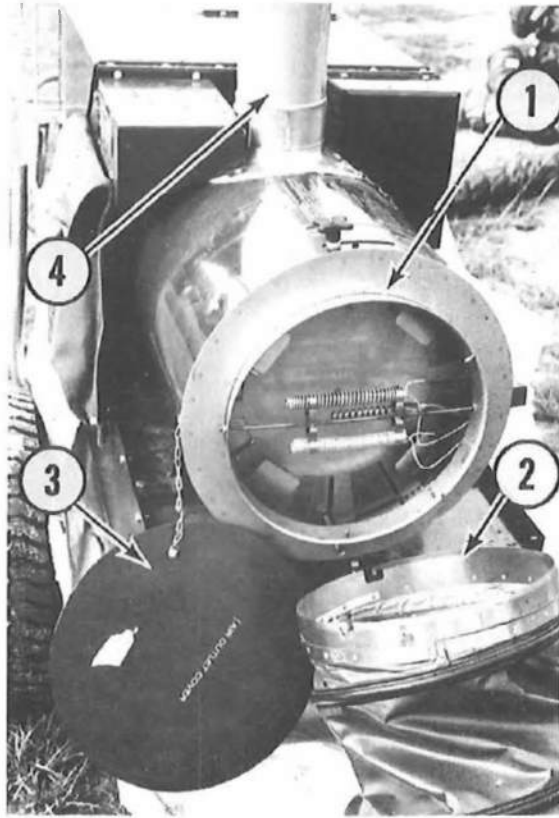

- |                                |                               |
|--------------------------------|-------------------------------|
| 1. Air Duct Connector Assembly | 2. 12" Diameter Main Air Duct |
| 3. Air Outlet Cover            | 4. Exhaust Stack              |

**Figure 105. Air Heater Showing Air Intake and Exhaust Components**

4. Remove the air outlet cover and expose the air duct connector assembly. Attach the 12" discharge air duct to the duct connector assembly and lock it in place by rotating the air duct clockwise.

5. Remove the exhaust stack cover on the top of the heater and simply insert the exhaust stack into place.

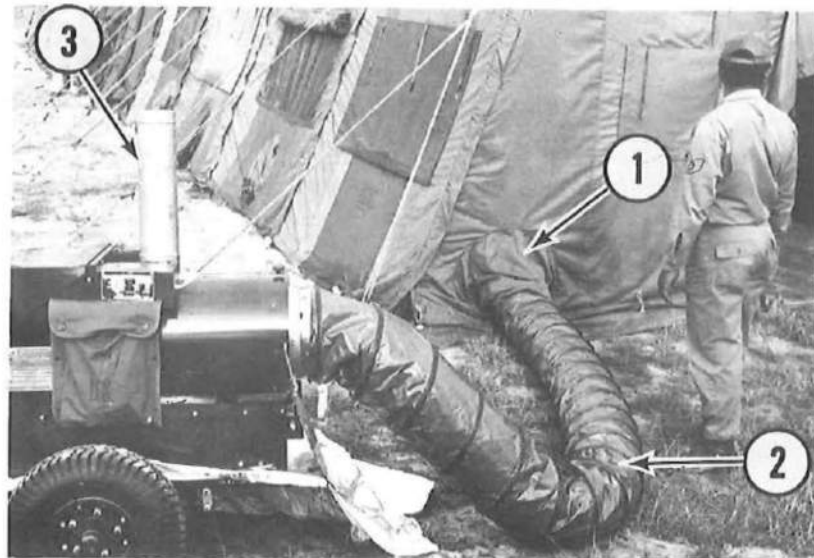

- 1. Ventilation Duct Opening
- 2. 12" Diameter Main Air Duct
- 3. Exhaust Stack

**Figure 106. Air Duct Connected to Dining Shelter**

6. Pass the open end of the 12" diameter air duct through a ventilation duct opening of the dining shelter. Tie the tent fabric tightly around the air duct to provide a good seal against water seepage and heat loss.

7. Locate the 12" diameter air duct adapter (which allows connection of 6" distribution ducts to the main discharge air duct) and the 6" diameter air ducts.

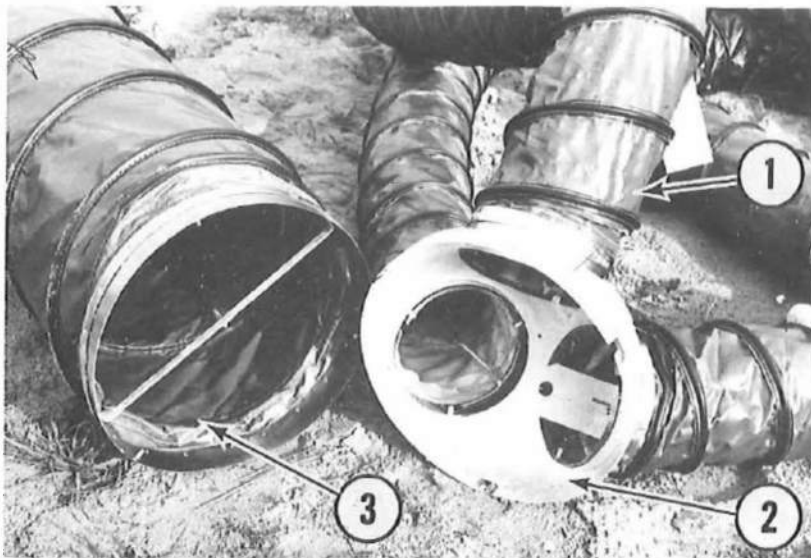

1. 6" Diameter Air Distribution Duct
2. 12" Air Duct Adapter
3. 12" Diameter Main Air Duct

**Figure 107. Air Duct Adapter Fitted to the Open End of the 12" Air Duct**

8. Move inside the shelter and attach the 12" air duct adapter to the open end of the 12" air duct. Next, attach three 6" air distribution ducts to the 12" adapter. The 6" air distribution ducts can now be extended throughout the shelter to direct heat to the desired areas.

## B. OPERATION

The tent heater is equipped with three (3) types of controls, located in a control box on top of the heater:

- a. Discharge Air Temperature;
- b. Fuel Control Valve; and
- c. Temperature Selector Knob.

These controls enable an operator to select the temperature of the discharge air and adjust the flow of fuel to the heat exchanger.

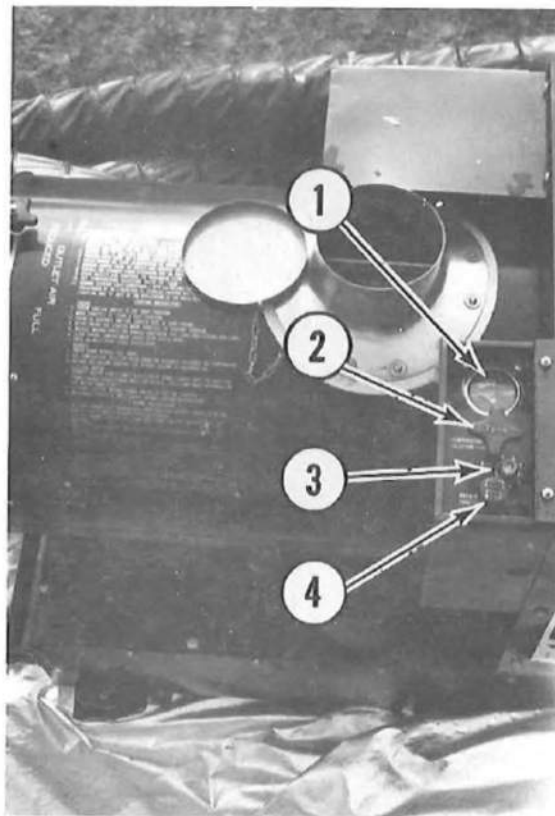

- |                                    |                              |
|------------------------------------|------------------------------|
| 1. Discharge Air Temperature Gauge | 2. Temperature Selector Knob |
| 3. Numerical Information Plate     | 4. Fuel Control Valve        |

**Figure 108. Controls and Gauge for the Air Heater**

- a. The discharge air temperature gauge is a dial-type gauge for measuring the discharge air stream temperature ranging from 150°F to 280°F.

b. The temperature selector knob corresponds to the numerical information plate just beneath it. Each number represents 25° F with #1 on the dial corresponding to approximately 150° F. Therefore, an operator can rotate the temperature selector knob clockwise to increase the discharge air temperature and counterclockwise to lower the air temperature.

c. The fuel control valve controls the flow of fuel to the combustor. When the Fuel Control Valve is depressed, fuel flows into the combustor and heat is produced for the heat exchanger. Conversely, when the valve is pulled upward (about 1/8 inch) the fuel flow is stopped, combustion ceases, and no heat is exchanged.

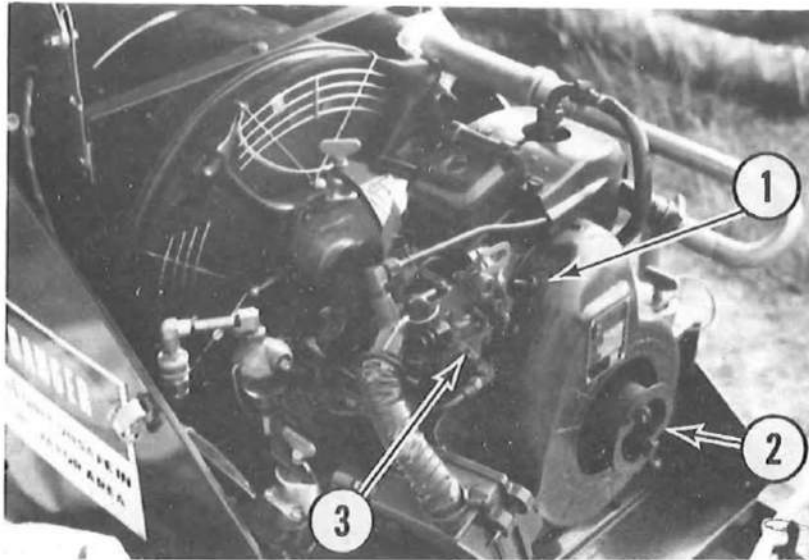

- |                |                     |
|----------------|---------------------|
| 1. Stop Switch | 2. Starter Flywheel |
| 3. Choke Lever |                     |

**Figure 109. Gasoline Engine Showing Essential Start-Up Parts**

1. Prepare to start the heater by undoing the latches of the engine cabinet and lifting the cabinet to an open position.
2. Check to make sure that the air outlet and exhaust stack covers have been removed and the air discharge duct and exhaust stack have been properly installed.
3. Remove the gas tank cap, adjust the cap valve to an open position and replace gas cap. The gas tank cap is located below the control box.

4. To start the gasoline engine:
  - a. Turn choke lever to a vertical (closed) position.
  - b. Place stop switch lever in the **RUN** position.
  - c. Wrap starter rope around the flywheel and pull vigorously to turn flywheel.
  - d. After engine starts, gradually move the choke lever to a horizontal (open) position.
5. Lower the engine cabinet to its closed position. Immediately **OPEN** the air inlet door on the front of the cabinet.
6. Depress the fuel control valve knob located in the control box.
7. Set the temperature selector knob to the desired discharge air temperature.
8. Adjust the damper control (above the duct adapter assembly) to the desired volume of heated discharge air.

**NOTE:** The tent heater is now fully operational.

#### **C. SHUTDOWN PROCEDURES**

1. Pull up fuel control valve knob to stop heater combustion.

**NOTE:** Allow the heater unit to operate at least two (2) minutes after the fuel control valve has been shut off.

2. Disengage the latches of the engine cabinet and lift it to an open position.
3. Set the stop switch lever to **OFF**.
4. Close the engine cabinet and secure latches.
5. After a cooling-off period, remove the exhaust stack and disconnect the air ducts.
6. Remove the duct adapter assembly.
7. Replace the air outlet cover and exhaust stack cover.
8. Compress air ducts and store them in the front wire basket and alongside the heater.



**SECTION VIII**  
**STEAMTABLE AND GRIDDLE ASSEMBLIES**

## OVERVIEW

The NHE steamtable and griddle combined unit is a prototype unit. This NHE equipment uses the remote tank or M-2 Burner System. The NHE griddle surface is a hard-coat aluminum alloy material which heats up and cooks in the usual way, but requires less scrubbing to keep clean. As its top surface can be marred and scratched easily, extra care is needed when scraping grease into the grease chute with a spatula. Do not pound surface with spatula, as it chips the hard-coat surface. You will notice that the griddle is reversible. Thus, if one cooking surface should become damaged, simply reverse surfaces.

The component parts of the steamtable and griddle combined unit are all pre-fitted and can be manually assembled without special tools. However, these pieces fit together quite snugly and a rubber-headed mallet may be needed to assemble and dismantle the unit.

## TRAINING OBJECTIVES

Given the separate components that make up a steamtable and griddle combined unit, the trainee must be able to demonstrate an ability to:

1. Identify the individual component parts.
2. Assemble them correctly.

## ASSEMBLY

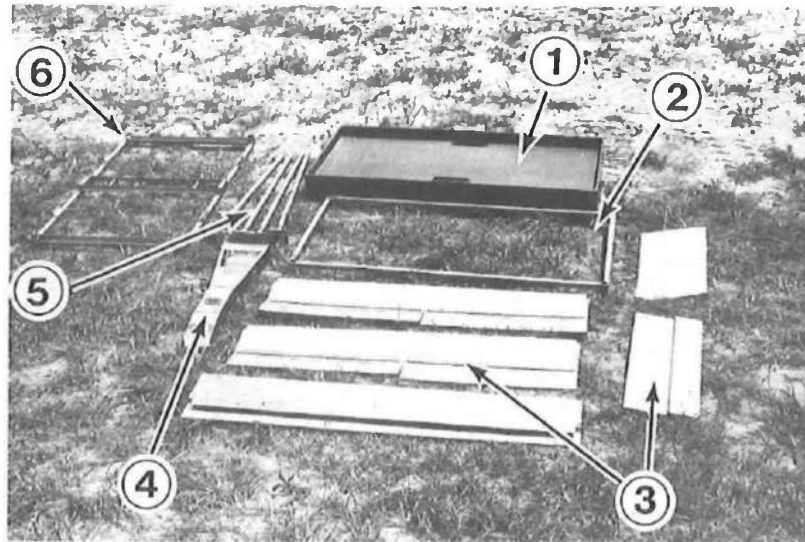

- |                 |                |                 |
|-----------------|----------------|-----------------|
| 1. Griddle      | 2. Upper Frame | 3. Flame Guards |
| 4. Grease Chute | 5. Legs        | 6. Lower Frame  |

Figure 110. Unassembled Griddle Assembly

1. The component parts for assembly of the Reversible Griddle are shown above.

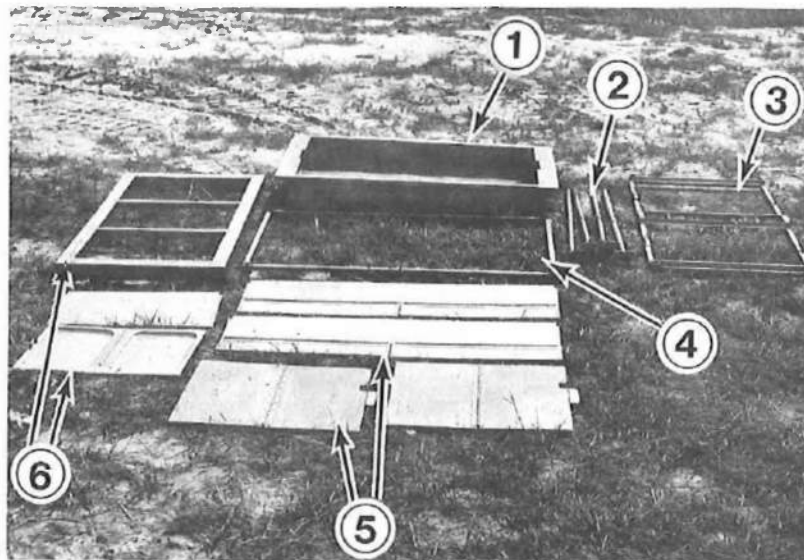

- |                |                 |                |
|----------------|-----------------|----------------|
| 1. Steamtable  | 2. Legs         | 3. Lower Frame |
| 4. Upper Frame | 5. Flame Guards | 6. Covers      |

Figure 111. Unassembled Steamtable Assembly

2. The component parts for assembly of the steamtable are shown above. Notice that the supporting frame pieces for the steamtable and the reversible griddle are identical.

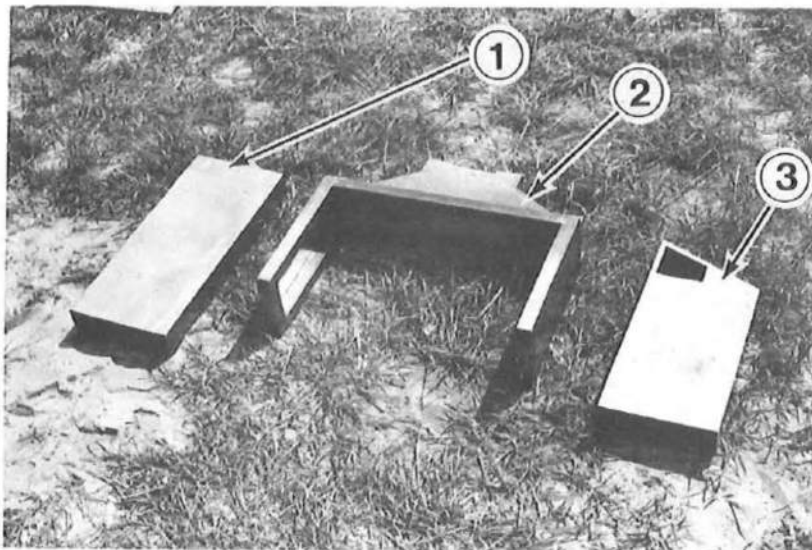

1. Lower Stack  
3. Upper Stack

2. Exhaust Housing

**Figure 112. The Burner System Exhaust Stack Assembly**

3. The combined unit is equipped with a burner system exhaust stack which has three parts as shown above, and is designed to channel combustion gases up and away from the cooks on the serving line.

4. Lay out the required component parts for the combined unit and prepare to assemble the lower frame.

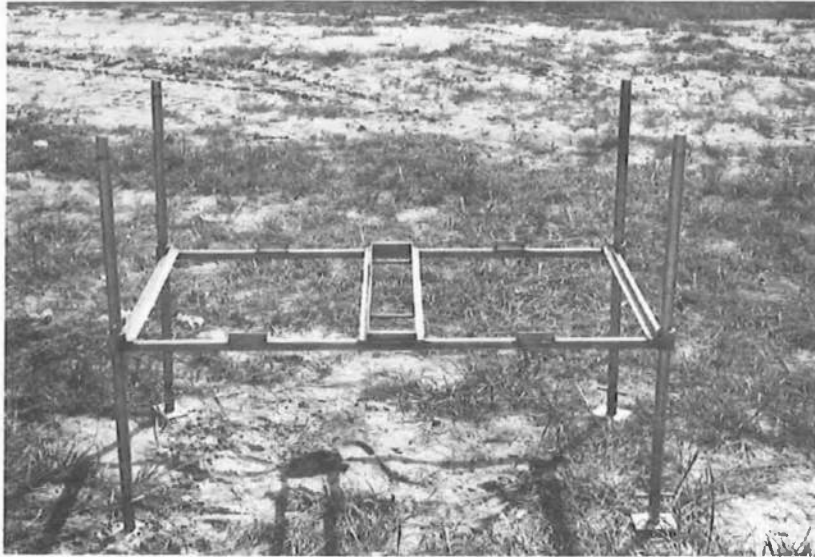

**Figure 113. Assembled Lower Frame**

5. Insert four legs into the collars at each corner of the lower frame so that their flat metal feet rest squarely on the ground and the frame does not rock. Repeat this procedure for the second lower frame and position it side-by-side with the first frame.

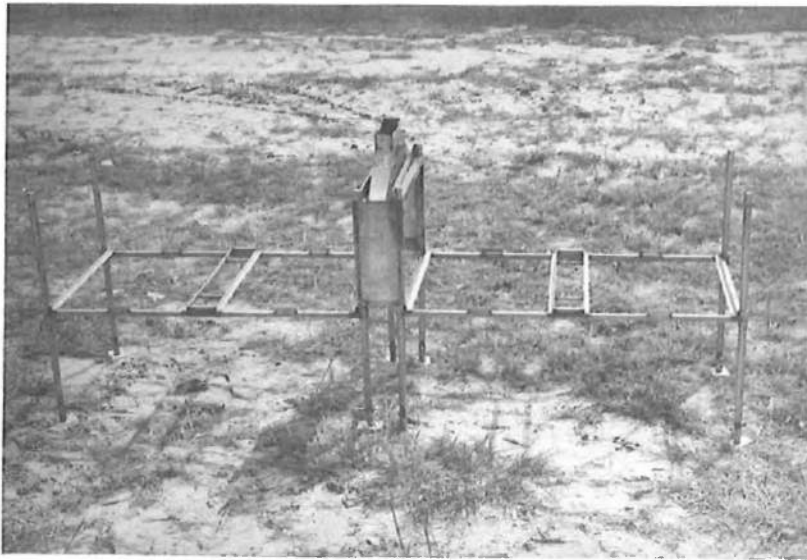

**Figure 114. Frames with Exhaust Housing Installed**

6. Identify the burner system exhaust housing and install it between the two adjoining frames by inserting four legs (two from each assembly) into the bottom corners of the housing. Slide the housing down until it sits snugly on top of the lower frame section.

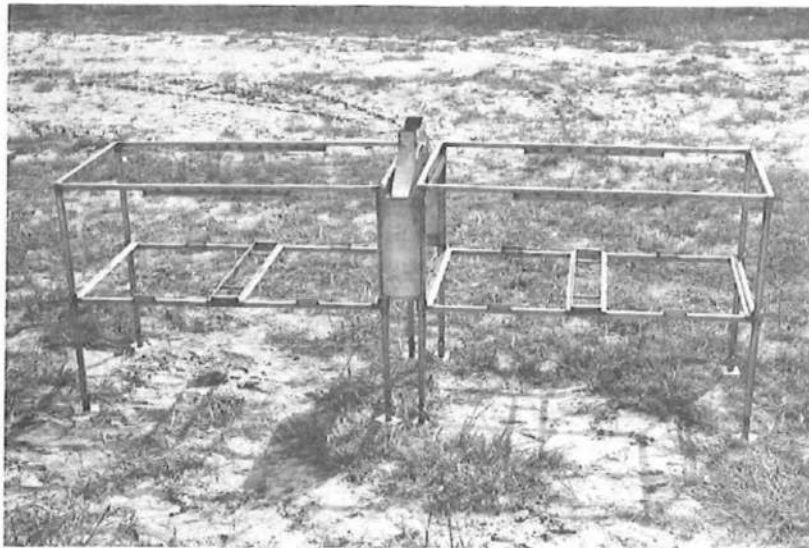

**Figure 115. Upper Frames Assembled**

7. Position the upper frame section over the legs so that the legs can be inserted into the four collars at each corner of the upper frame. Be certain that the installed upper frame section is level and flush with the top of the legs.

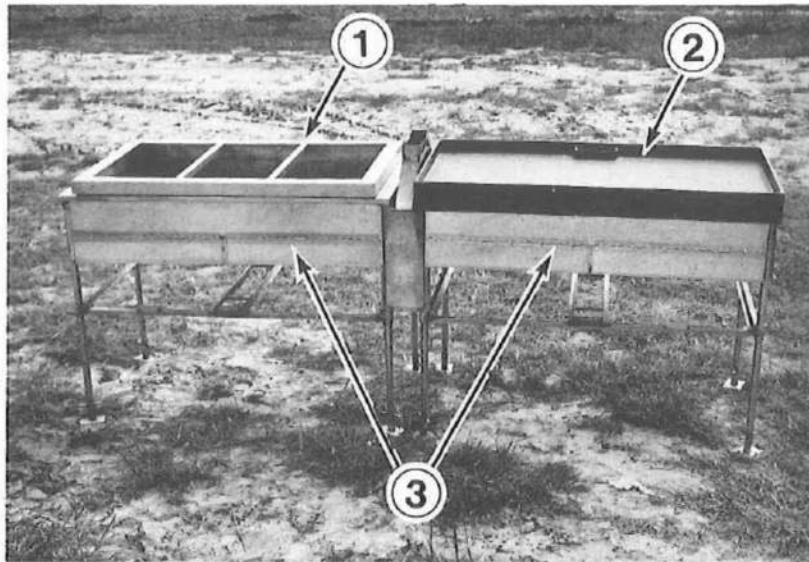

1. Steamtable  
3. Flame Guards

2. Griddle

**Figure 116. Flame Guards Installed on Griddle and Steamtable**

8. Install the front, back, and side frame guards next by hanging them on the edge of the upper frame section. The hinged portion will be nearest to the ground. These flame guards will protect the cooks from the heat of the burners under the steamtable and griddle, and are hinged to facilitate installation and removal of burner units.

9. Either the griddle or the steam table can now be installed. As they are heavy and somewhat awkward to move, it is recommended that two people carry each of them and coordinate the steps for installation. These items fit snugly when placed inside the upper frame section, and may need to be gently tapped down until they sit level and securely in place. Note that the recessed opening in the griddle surface for the grease chute is at the front while the raised opening in the griddle surface is at the back.

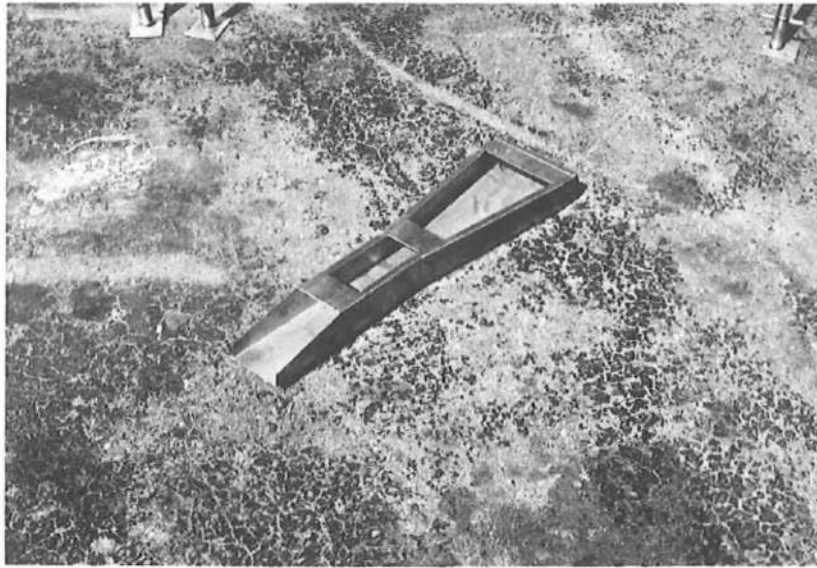

**Figure 117. Grease Chute**

10. Identify the grease chute and install it so that the uppermost end fits tightly up around the collar of the grease chute opening underneath the griddle.



1. Grease Chute

2. Bracket

**Figure 118. Correct Positioning of the Grease Chute**

10a. The grease chute is inserted into the middle portion of the lower frame section and pushed downwards until the wider section of the grease chute can clear the flame guards and swing under the table top. Note that the chute bracket is shaped to engage the lower frame section in only one direction and therefore, the bracket must be on the underside of the grease chute during this installation.

10b. Lift the wider part of grease chute up around the collar of the grease chute opening underneath the griddle and simultaneously move the metal bracket against the bar on the lower frame section to engage it. As the grease chute is lowered about 1/2", the metal bracket will engage the bar and installation is now complete. Any excess grease should flow through the griddle surface opening, down the chute and into an appropriate receptacle (such as an empty can). Note that proper installation (i.e., the grease chute fitted tightly around the underside of the griddle opening and securely held in place by the metal bracket engaging the support bar) will insure that the excess grease flows into the disposal can rather than onto the floor.

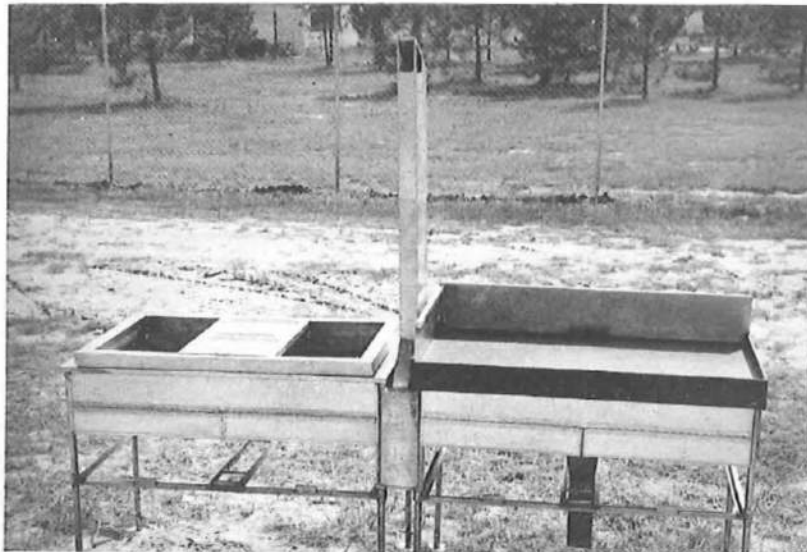

**Figure 119. Fully Assembled Steamtable and Griddle**

11. Complete the assembly of the steamtable and griddle unit by placing the lower and upper sections of the exhaust stack into position as shown above. The top section can be identified by its vent opening.

**SECTION IX**  
**THREE SINK ASSEMBLY**

## OVERVIEW

The sink assembly is a prototype unit consisting of a sink body, burner rack, base, and drain table, as shown in Figure 120. Faucets provide water to the sinks and are connected by QD (quick disconnect) couplings to water hoses running from the portable water heater and circulation pump.

## TRAINING OBJECTIVES

Given the separate components that make up the sink assembly, the trainee must be able to demonstrate an ability to:

1. Identify the individual component parts.
2. Assemble them correctly.

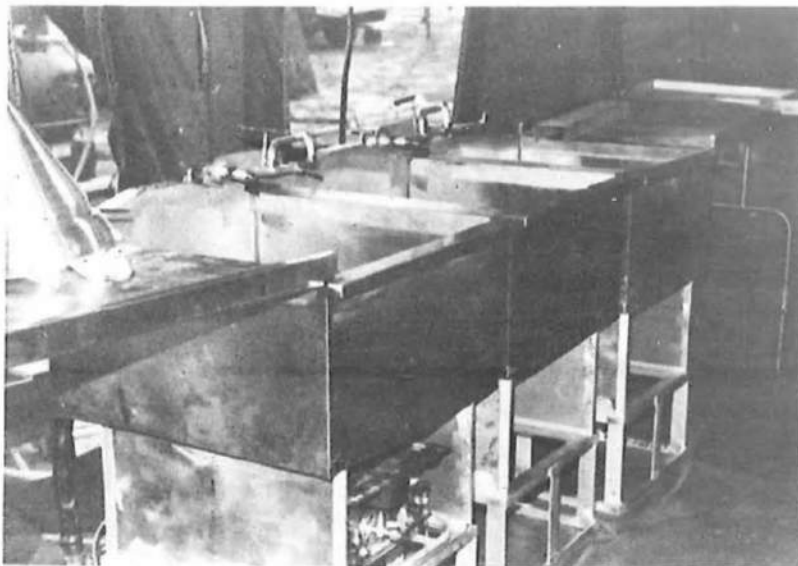

**Figure 120. Complete Three Sink Assembly**

## ASSEMBLY

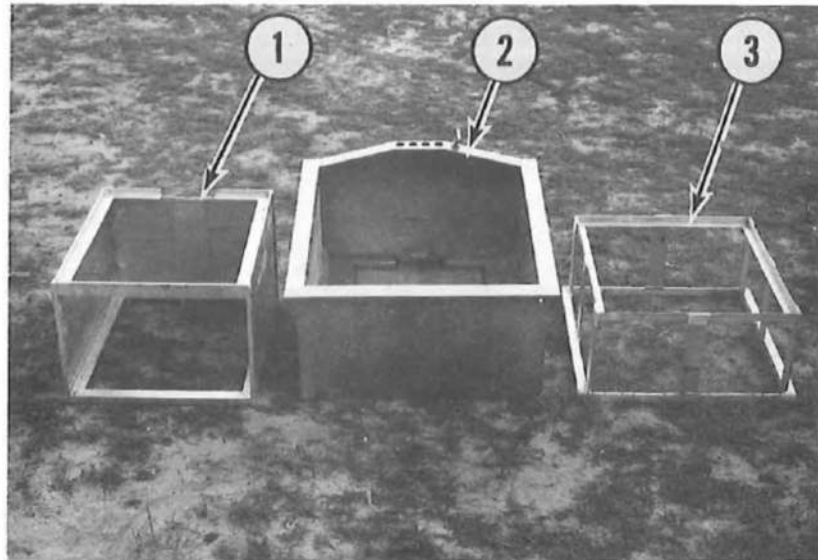

1. Burner Rack  
3. Base

2. Sink Body

**Figure 121. Sink Components**

1. Distinguish between the base and the burner rack. Lay out the base piece so that the flush frame portion rests on the ground and its recessed inner "ledge" portion is uppermost to support the burner.

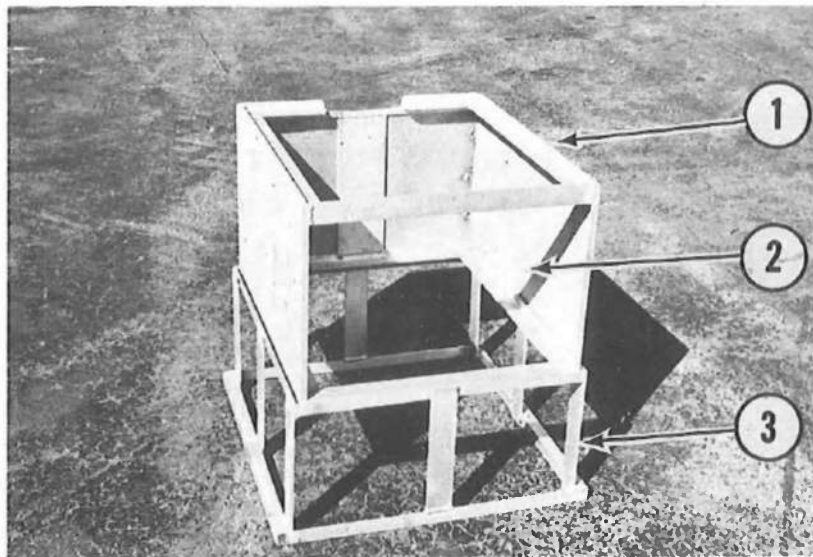

1. Burner Rack
2. Fire Screen
3. Base

**Figure 122. Burner Rack in Place**

2. Place the burner rack on top of the base by lowering it onto the frame "ledge" support. The burner rack has a mesh "fire-screen" on three sides. The open side should be at the front of the sink so that a burner unit can easily be placed beneath the sink and serviced from the front.



**Figure 123. Sink Body in Place**

3. Place the sink body on the burner rack. Be certain that it fits snugly into position and sits level on its base.

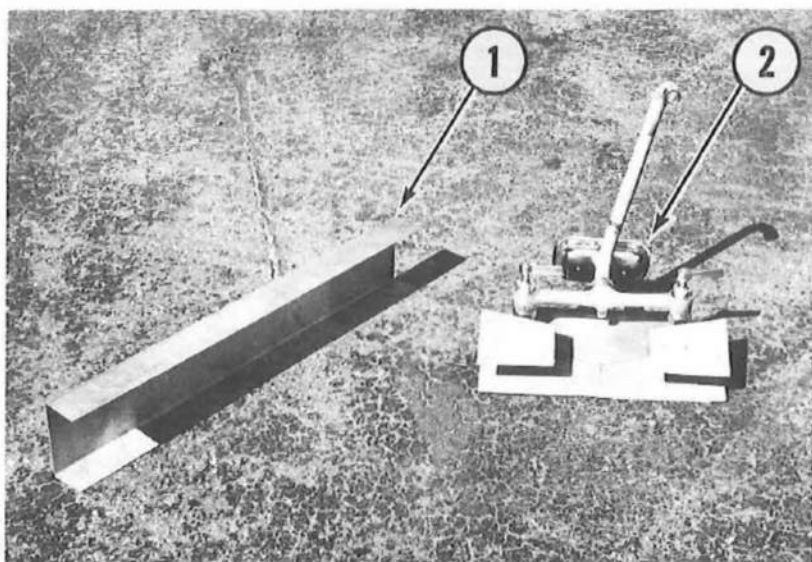

1. Sink Adapter

2. Sink Faucet Fixture

**Figure 124. Sink Adapter and Sink Faucet Fixture**

4. Locate the sink faucet fixture and the metal "sink adapter" which is used to join two sinks together. The "sink adapter" will prevent water from spilling on the shelter floor when a running faucet swings from one sink basin to the next.

5. Assemble a second sink by following the procedures in steps 1–3.

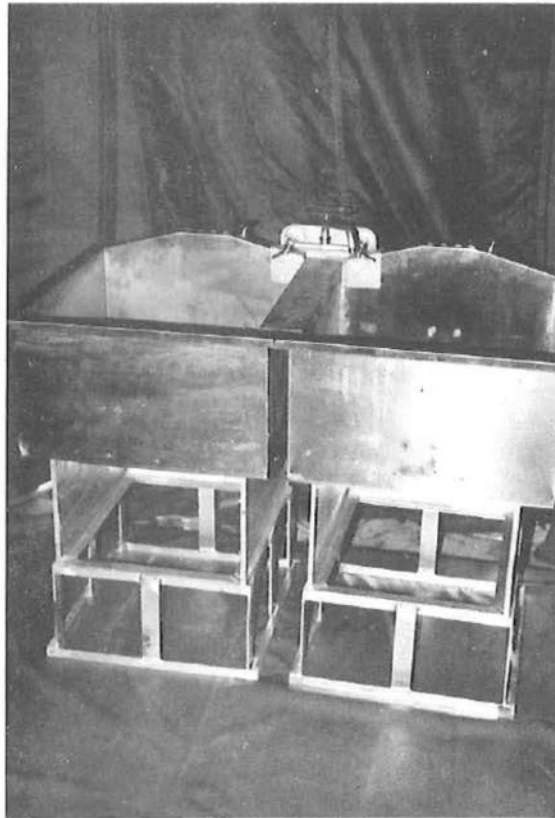

**Figure 125. Sinks Joined Together**

6. Position the two sinks side by side so that the lip of each sink almost touches. Be certain that the open portion of the burner rack is facing frontwards. Place the metal "sink adapter" over each sink lip to join them tightly together.

7. Place the sink faucet fixture over the back edge of both sink bodies so that it straddles the "sink adapter." Note that the faucet itself is positioned directly above the metal "sink adapter."

8. Assemble a third sink by following the procedures in steps 1–3. Place the third sink assembly next to the two previously assembled sinks and join them by following the procedures in steps 6 and 7.

9. Sink drain tables are provided for use on both sides of the sink assembly. On the side closest to the kitchen, two (2) drain tables are placed in an "L" shape. These tables are for temporary placement of soiled pots and pans. A single drain table is placed on the opposite end to provide a place for pots and pans to drain after they have been sanitized. The sink drain tables have legs and angle supports, and are set up by folding the legs down and pushing the angle supports into place.

10. After connecting the hot and cold water hoses to the sink assembly, it is ready for use. Be certain, however, that the sinks drain properly out to the grease trap.



**SECTION X**

**TRAY PACK**

## OVERVIEW

The tray pack is an innovation in packaging for the food service market as well as for military feeding systems. Tray packs are hermetically-sealed containers of ready-to-eat foods that can be transported and stored without refrigeration, until needed. Most importantly, tray packs can be rapidly heated "as is" in customary heating media (hot air, steam, and boiling water) and can be served directly from the container. Rapid heating results not only in savings in time, but in savings in energy and improvement in nutrition retention and food quality. Choices of foods available in tray packs include vegetables, starches, entrees, and desserts.

## TRAINING OBJECTIVES

1. To familiarize the trainee with the different types of equipment for heating tray-packed foods to serving temperatures.
2. To learn the procedures for heating, opening and serving tray-packed products.
3. Develop techniques of handling this new item in the kitchen and in storage.

### A. PACKING/SHIPPING/STORAGE INSTRUCTIONS

1. **Packing.** Four cans of product shall be packed in a snug-fitting fiberboard box described below. The cans shall be packed flat, four in depth within a style RSC box. The inside of each box shall be provided with a box liner and five fiberboard pads. The pads shall be placed between the cans and on the top and bottom of the stacked cans. The pads shall be full length and width less approximately 1/4 inch in each dimension. The box liner and pads shall be fabricated of grade V3c fiberboard.

2. **Shipping containers.** Fiberboard boxes constructed, closed and reinforced in accordance with PPP-B-636 as follows:

Type — CF	Style RSC
Class — Weather-resistant	Grade — V3c

Each box shall be reinforced with nonmetallic strapping or pressure-sensitive adhesive, filament reinforced tape applied one lengthwise and one girthwise.

3. **Unit loads.** The shipping containers shall be arranged in unit loads in accordance with type I, class D of MIL-L-35078. Alternatively, each unit load shall be bonded with stretch film in accordance with MIL-STD-147, except when using PVC or EVA film. Then, a minimum of six wraps is required.

4. **Labeling of cans.** Cans shall be labeled to comply with the Federal Food, Drug and Cosmetic Act and regulations promulgated thereunder. In addition, labeling shall include the following requirements. The name of the product or abbreviation thereof and date of pack (day, month, year) shall be stamped on the end of the can. The markings on the can shall be legible after exposure to boiling water for 30 minutes.

5. **Marking of shipping containers.** Shipping containers shall be marked in accordance with MQ Notice (MG) 894A.

6. **Marking of unit loads.** Unit loads shall be marked in accordance with MIL-L-35078.

**NOTE:** The USDA and NLABS maintain the right to verify, using appropriate test procedures, that packaging and packing materials used comply with those requirements.

7. **Storage.** Tray packs are shelf-stable and do not require refrigeration. They may be stored until needed in their fiberboard shipping cases if the storage area is cool and dry. Tray packs, however, should not be regarded as nonperishable commodities which do not require care or protection in storage. While tray packs are not nearly so susceptible to spoilage as fresh produce, spoilage can and will occur if the products are mishandled, improperly stored, or stored for excessive periods of time.

## **B. INSTRUCTIONS FOR HEATING**

Tray packs can be heated "as is" in standard food service equipment with customary heating media. They can be heated in conventional ovens and steamers provided one notable precaution is observed—**THAT THE TRAY PACK IS OPEN.** When oven heating, pierce the container lid at several points across the surface to prevent pressure development at oven temperature.

Tray packs can also be heated by submerging **UNOPENED** containers in boiling water. A 15-gallon stockpot and a tilt grill are two vessels that can be used for water heating.

So that it may be used for heating tray packs, the standard stockpot cradle has been modified with sheet metal to provide a flame guard and to heat the pot more efficiently from below. Use a thermometer to verify that the water temperature does not fall below 165°F throughout the heating period. The stockpot should be only half-filled with water prior to loading the tray packs. The trays should be placed to rest on their short side (end) in an upright position to maintain proper water circulation during heating. The capacity of the pot is seven (7) tray packs.

The tilt grill may also be used for heating tray packs. Fill the tilt grill about one-half full of water and when the water is boiling, place the unopened tray packs in the water. Be sure that the temperature of the water does not fall below 165°F throughout the heating period.

Heating times vary according to the contents of the tray pack. Use the following as a guide:

Tray Pack Contents	Heating Time (In boiling water – 212°F, or oven heating at 350°F)
Entree	30–35 minutes
Vegetables	8–15 minutes
Starches	10–15 minutes
Other	8–10 minutes

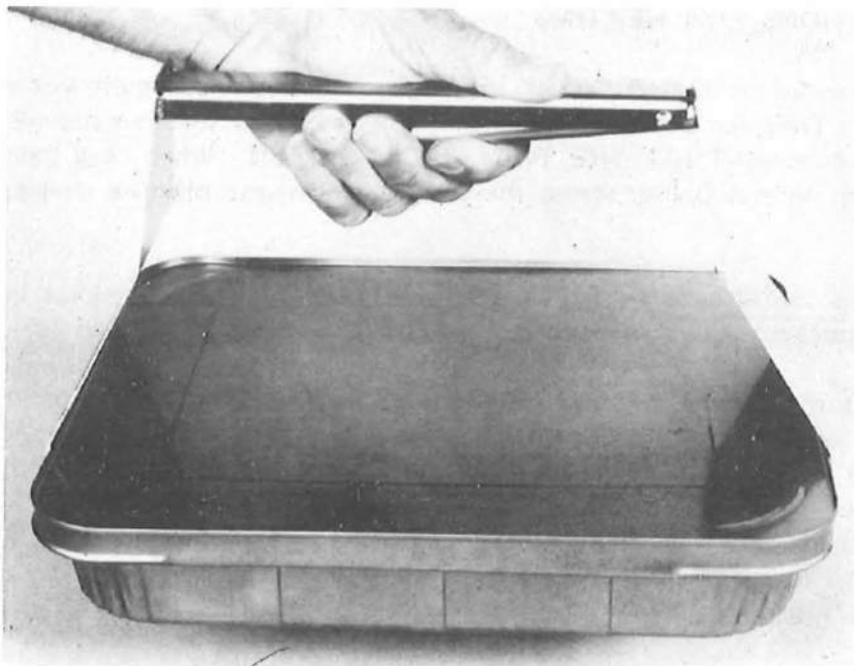
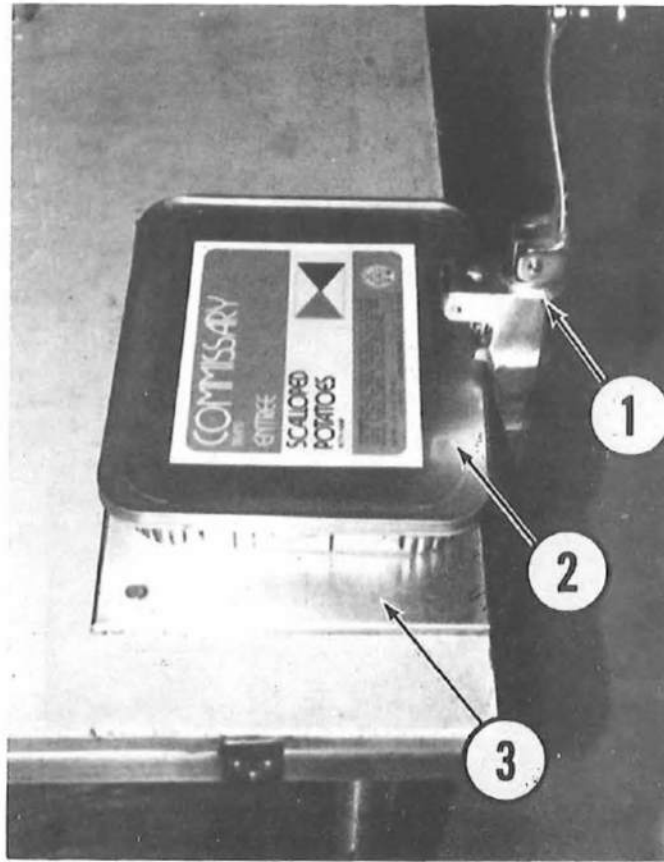

Figure 126. Tray Pack and Lifter

To remove the hot tray pack from the boiling water, use a tray lifter or extractor provided among your kitchen utensils. Make sure that the extractor has a secure grip on the side of the tray pack before you lift it out of the water and carry it to the holding cabinet. The holding cabinet temperature is to be maintained at 165°F until the serving line.

### C. INSTRUCTIONS FOR OPENING



1. Manual Can Opener
2. Tray Pack
3. Metal Place on Tabletop

Figure 127. Tray Pack Positioned for Opening

When ready to serve, open each tray pack with the institutional-type Edlund No. 1 manual can opener. Clean cloth pads or gloves may be used to avoid burning your hands while opening the trays.

With the can opener handle in an upright (open) position, move the tray pack directly under the knife-edge of the opener. Lower the opener to puncture the tray pack lid. Lower the handle to lock the tray pack in the opener. Gently guide the tray pack with one hand (protected by a clean cloth pad or glove) while the other hand operates the opener in the usual manner—rotating the handle to cut along the lid. Raise the handle to free the tray pack when the lid has been cut around completely. Remove the lid and dispose of it in an appropriate manner.



**Figure 128. Tray Packs in Steamtable on Serving Line**

**SECTION XI**  
**OTHER FOOD SERVICE EQUIPMENT AND SUPPLIES**

A. DINING SHELTER

Table 6. Food Service Equipment and Supplies for Dining Shelter

Description	Quantity	Requirements	Comments
1. Coffee Brewers Bunn RL-35	2	Elect. 120/240V AC, 60 Hertz, 3 wire, 1-phase, 20 amp  Water Filterpapers	Operating Instructions are included in the manufacturer's notes that accompany the item. Standard operation except pour-over procedure when not connected to water line.
2. Toasters; Electric, Conveyor Continuous, 540 slices per hr.	2	Elect. 115V AC, 60 cyc	Standard operation.
3. Chairs; Folding, tubular metal frame, metal seat and back	200	---	
4. Tables; Folding legs, wood top, metal frame, 72" x 30"*	40	---	
5. Dispensers; Condi- ment Counter Top SS. Stand & Con- tainers (30 oz. Containers)	4	---	
6. Small Equipment and Supplies; Pitchers, 5 qt. Waste Cans	24 24	--- ---	
7. Disposable Supplies; Napkins, Utensils, Plates, Bowls, Straws, Cups, Can Liners, Sanitation Supplies			

**Table 6. Food Service Equipment and Supplies for Dining Shelter (cont'd)**

Description	Quantity	Requirements	Comments
8. Individual Pack Condiments; Salt, Pepper, etc.			

\* It has been required by Air Force Engineering and Services Center personnel to increase the number of dining shelter sections from 11 sections to 13 sections (one at each end—Figure 18A). It is anticipated that the two additional 8' sections and the combination of 8' long and 6' long tables will increase the seating capacity to 220 (Figure 18A). The following items are required for the 220 capacity configuration:

Item	Quantity	Manufacturer	Model
** Folding Table 30" x 96" (dining)	16	Correll, Inc.	F3096P
Folding Bench 15" x 96" (dining)	28	Correll, Inc.	F1596P
Folding Table 30" x 72" (dining)	10	Correll, Inc.	F3072P
Folding Bench 15" x 72" (dining)	20	Correll, Inc.	F1572P

\*\* Two (2) to be used in dining area for condiment, beverage, dessert, etc., tables.

## B. KITCHEN SHELTER

Table 7. Food Service Equipment and Supplies for Kitchen Shelter

Description	Quantity	Requirements	Comments
1. Steam Tables (Serving Line)	2		
a. Electric, 4 Full or 8 Half Size Rectangular Pans, No Protector		Elect.  Water, Drain	Fill with water to level mark and preheat before inserting food. Operate to maintain food at 140°F or above.
OR			
b. Gasoline Burner, Fried, 4 Full or 8 Half Size Rectangular Pans		Water, Drain, Gasoline Burner System	Fill with water and pre- heat before inserting food. Operate to maintain food at 140°F or above.
2. Tilt Grill; Electrical Model FPC-4	1	Elect. 208V 3 ph 40 amp 14.5 kw	Operating instructions are included in the manufacturer's notes that accompany the item. Unit may be used for braising, shallow frying, or boiling water to heat tray packs.
3. Potato Extruder; Electric	1	Elect. 115V 1 ph 12 amp	Operating instructions are included in the manufacturer's notes that accompany the item.
AND/OR			
4. Potato Extruder; Manual	1		Same as 3.
5. Refrigerator; Upright, Reach-in	1	Elect. 115V 1 ph 6.3 amp	Operate to maintain food at 40°F or lower. This is a standard food service refrigerator. Check tempera- ture periodically.

Table 7. Food Service Equipment and Supplies for Kitchen Shelter (cont'd)

Description	Quantity	Requirements	Comments
6. Ventilator; Proximity, Jennair Model No. PV 300	1	Elect. 115/230V 60 cyc 1 ph 8.8 amps at 115V 4.4 amp at 230V	Operating instructions are included in the manufacturer's notes that accompany the item. Inspect filter and grease fry after each use of deep fat fryer. Clean as necessary.
7. Filter for Deep Fat Filter; Dean Model MF-90A	1	Elect. 115V 60 Hertz 7.8 amp  Filterpapers Filter Aid	Operating instructions are included in the manufacturer's notes that accompany the item. Wear hand and eye protection when filtering hot fats.
8. Deep Fat Fryer; Electric, McGraw- Edison Toastmaster Model 1456TC (with top cover)	1	Elect. 208V 3 ph 40.2 amps	Operating instructions are included in the manufacturer's notes that accompany the item. Fire extinguisher located near fryer.
9. Meat Slicing Machine; Electric, Table Type	1	Elect. 115V 60 cyc 1 ph	Standard operation.
10. Holding Cabinets; Electric, Model H-138-1834 Series, Cres-Con (12)	2	Elect. 115V 1 ph 13 amp	Operating instructions are included in the manufacturer's notes that accompany the item. Preheat cabinet before loading with food. Check heat distribution with thermometer.
11. Ovens; Convection	4	Gasoline Burner System	
12. Cook Pot Cradles	3	Gasoline Burner System	
13. Cook Pots	3	60-Quart	

### C. SANITATION AND STORAGE SHELTER

Table 8. Food Service Equipment and Supplies for Sanitation and Storage Shelter

Description	Quantity	Requirements	Comments
1. Can Opener; Electric, Hand Held, Edlund Model No. 201, Fan Cooled, 1/8 hp	1	Elect. 115V	
2. Can Opener; Manual, Bench Mounted	1		Modified plate to permit opening of tray packs.
3. Ice Making Machine; Cube, Auto Dispensing, 400 lbs ice cap. per 24 hrs.	1	Elect. 230V 60 cyc 1 ph 15 amp Water Drain	Standard operation. Monitor frequently to assure continuous water supply.
4. Vegetable Cutter; Electric; Slicer, Grater, Shredder	1	Elect. 120V 1 ph 5.1 amp	
5. Coffee Brewer; Bunn OL.15		Elect. 120V 1 ph 15 amp Filterpapers	Operating instructions are included in the manufacturer's notes that accompany the item.
6. Refrigerator; Walk-In, Portable Type, 150 cu ft capacity with Refrigeration Unit, Mech Panel Type, 5,000 BTU/hr	3	Elect. 208V 3-phase 19 amps	Check temperatures periodically.

\*As of this writing the subject of refrigeration capacity is under review by the Air Force Engineering and Services Center. Their present, tentative recommendation is to increase the "reefer" capacity and to convert to 450 cu ft units.

**SECTION XII**  
**MANUFACTURERS' OPERATION AND MAINTENANCE**  
**INSTRUCTIONS**

## OVERVIEW

The following has been extracted from manufacturers' manuals for specific commercial equipment. It is made available to assist the user for the routine operation and maintenance of the major pieces of this system which were not previously found in field feeding systems.

The following items are included:

- A. Bunn-O-Matic Coffee Brewers
- B. Deep-Fat Fryer
- C. Ventilator for Deep-Fat Fryer
- D. Grease Filter for Deep-Fat Fryer
- E. Automatic Potato Extruder
- F. Hand Operated Potato Extruder
- G. Tilt Fry/Braising Pan
- H. Insulated Hot Food Cabinet
- I. Refrigerator, Upright, Reach-In

**A. BUNN-O-MATIC COFFEE BREWERS**

- IMPORTANT:**
- Electrician's and Plumber's instructions are provided on Page 2. These instructions should be carefully followed before proceeding with initial operation instructions.
  - Be sure all electrical and plumbing connections are tight.
  - Top lid of brewer should be level for proper operation.

1. Turn power to brewer ON.
  2. Place brewing funnel in proper position for brewing. Place a decanter containing a little water on center warmer and turn ON-OFF toggle switch to the ON position. This switch must be ON to operate a brew cycle.
  3. Deflect the start switch. This will start a brew cycle and allow water to flow into the tank. The brew cycle will run for approximately three minutes. Repeat the brew cycle two more times allowing approximately three minutes per cycle. Water should overflow tank into the decanter on center warmer during the third cycle.
  4. This brewer has been factory-set to deliver 64 ounces of water each cycle regardless of water line pressure variations. If less than 64 ounces of water is desired, an adjustment may be made to deliver less water. Turn power OFF and remove the top lid via (3) three screws and remove the spring clip on top of the water level switch. Each washer on top of the magnetic spool represents 2 ounces of water. If 62 ounces of water is desired, remove one washer. If 60 ounces of water is desired, remove two washers. Be sure to replace spring clip on top of water level switch.
  5. Turn power OFF and remove front panel via four screws. Turn control thermostat knob clockwise to a 4 o'clock setting. Turn power to brewer ON and allow approximately 10 to 20 minutes for water in tank to heat. (RL35-OL35 approximately 10 minutes—OL20 approximately 15 minutes—OL15 approximately 20 minutes.) When the water reaches brewing temperature, the control thermostat will click off and the heating noise will stop. On initial heat up, normal water expansion will occur in the water tank. Water may drip from the funnel due to this expansion, but will not occur thereafter.
  6. Turn ON-OFF switch to the ON position. Place empty decanter on center warmer under the funnel, deflect start switch and run a cycle of water to remove expanded water from tank and to cycle control thermostat.
  7. When control thermostat clicks off and heating noise stops, run a cycle to check for proper temperature setting. With an accurate thermometer, take the temperature of the water at the point below the funnel opening and at the time when the decanter is about half full. Recommended temperature of the water is approximately 195°F. The water temperature may be increased by turning thermostat knob clockwise.
- NOTE:** Proper adjustment to final temperature setting is best done by gradually increasing thermostat setting upward. Adjustment of temperature setting downward is much harder due to previously overheated water remaining in the tank.
8. If water volume and temperature are correct, replace front panel. Coffee brewer is now ready for brewing coffee.

## COFFEE BREWING DIRECTIONS

FAST, CLEAN, CONVENIENT — BUNN® DISPOSABLE PAPER FILTERS



Drop Bunn filter into funnel.



Pour in fresh coffee.



Slide funnel into head and brew.

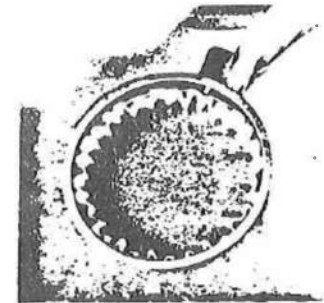

Simply throw out grounds.

1. Place Bunn filter in funnel and add desired amount of coffee.
2. Level the bed of coffee and insert funnel in hood guides.
3. Place empty decanter on center warmer under funnel.
4. Turn on-off toggle switch to the "ON" position, deflect start switch and brew a pot of coffee.

**IMPORTANT!** Use Bunn Filters for Bunn Coffee Brewers. There is a difference.

## CLEANING TIPS

1. For cleaning all metal surfaces, use any reputable stainless steel cleansing compound.
2. Sprayhead should be checked and cleaned regularly. (At least once a week.) Sprayhead holes must be kept open.
3. To prevent "LIMING" problems in the water tube and air tube, remove sprayhead and insert spring probe all the way into the tank through both tubes. When inserted into tank properly, no more than two inches of the spring should be visible. Saw back and forth five or six times. This will keep tubes open and clear of lime. In hard water areas this should be done every day; this takes less than a minute.

**B. DEEP-FAT FRYER**

## 4. OPERATION

4.1 General - Although the finest materials, engineering planning, and manufacturing facilities have provided for safety and trouble free operation, only proper use and maintenance will assure personnel safety and long life of the equipment.

The following is a list of safety precautions for operator(s) of this equipment.

- (a) **KEEP THE FAT LEVEL ABOVE THE TOP HEATING ELEMENT.** Failure to do this will result in overheating of the element sheaths and possibly flash fire if fat is splashed on them.
- (b) De-energize fry kettle at the end of each day's operation.
- (c) Do not leave fry kettle in operation without an attendant.
- (d) Turn thermostat dial down to 250 or turn off by pressing "OFF" switch, when the fryer is not in active use.
- (e) As the frying fat is being used it is wearing out, consequently the flash point (the temperature at which fire may result by overheating of the fat) becomes lower. Replace old fat with new when it begins bubbling excessively without food immersed, by taste of foreign flavors, or when gummy film collects on fry baskets.
- (f) Keep the exterior of the fry kettle clean of splashed grease.
- (g) Do not lift heating element assembly out of fat when elements are energized.

## 4.2 Operator's Information

- (a) Swing up element assembly contains all the heating elements and temperature controls. The element assembly may be held out of the fat at an intermediate 45° angle or at a 90° position. In either case it must be manually released to return to operating position in the fat container.
- (b) Baskets - Twin style baskets are furnished with the fryers. Full size baskets are available as additional equipment
- (c) Overall "On-Off" switches are provided at the front of the unit. A green signal light glows when fryer is energized.
- (d) The temperature control thermostat automatically maintains fat at selected temperatures from 250-400°F. It also de-energizes the elements when turned to the "OFF" position.
- (e) The operating signal light is amber in color, glows when the temperature control is turned to any heating position indicating the elements are energized; goes out

when fat temperature reaches control dial setting. The signal light will again glow during operation to indicate selected temperature setting is being automatically maintained.

- (f) An auxiliary manual reset thermostat is standard equipment. The second thermostat is installed in the electric circuits of the models, and will interrupt the electric current to the heating elements, in case of overheating of the cooking oil. A red signal light will glow when the auxiliary thermostat breaks the circuit, indicating that the cooking oil is overheated. The device should not be operated under these conditions. Manual reset for the auxiliary thermostat is incorporated into the "On-Off" switches at the front. After the cooking oil has cooled to a safe temperature, first push the "OFF" switch in the control panel and then push the "ON" switch to re-energize fryer. If this condition repeats itself, turn fryer off and call an authorized agency to take care of the necessary repairs.
  - (g) **The Heating Cycle** - The heating elements are energized periodically during the frying of foods. Progressive heating of the fat from the bottom and all 4 sides creates turbulence and thorough mixing of the hot fat resulting in even temperature distribution in the frying zone above the heating elements. Adequate sediment space below the heating elements is comparatively undisturbed. Keep the fat level above the top heating element at all times.
  - (h) The green signal light must go off when the "OFF" switch is pressed. If it does not, call an authorized service agency for necessary repairs.
  - (i) Fat expansion is approximately 25% of capacity from room temperature to 400°F
- 4.2.1 **Choose A Good Fat** - You will want to choose a fat made especially for commercial deep fat frying. The investment in good quality fat will be rewarded with a long time use and fried foods of high standards. Fat for frying should be bland in taste so it will not impart off flavors to foods. It is essential that the fat selected have a high smoke point, well above the recommended frying temperatures. When the fat reaches its smoking point, it begins to break down and become indigestible. Even with normal use the composition of fat changes and the smoking point becomes lower as it is used. Generally hydrogenated fats, because of their high smoke point and resistance to

## FRY KETTLES

break down, are considered ideal for deep fat frying. There are a number of reliable concerns packing fats of this type who guarantee the smoke point of their product to be well above 400° F.

### 4.3 Prepare For Operation

- (a) Be sure the thermostat dial is at "OFF" position before energizing the fry kettle for day's operation.
- (b) Fill the fat container with required amount of fat. NOTE: If solid fat is used, pack tightly around heating elements. Set thermostat to 250° until the elements are immersed in fat.
- (c) If fat has been used before, set thermostat to 250° until the fat has melted in fat container. Do not start fryer from cold (OFF) to high temperatures because heating element sheath temperature rises continually while elements are energized resulting in scorched fat and hastened shortening breakdown.
- (d) After fat is melted in fat container, set thermostat dial to desired temperature, wait until amber signal light goes out and proceed with frying.

### 4.4 Deep Fat Frying

- (a) Use the cooking guide on page 6 for amount of food per basket load to obtain best results.
- (b) Whenever possible, drain and dry foods before frying. Excessively moist foods break down shortening, hydrolyzing fat thus releasing fatty acids. Such fats will soon begin to smoke and its frying value is decreased considerably.
- (c) Save frying time by lowering the basket into the fat immediately after the signal light goes out. At this time the fat is at the peak of the temperature cycle.
- (d) Don't drop basket of food into the fat, lower it gently. Have all pieces in each load as nearly uniform as possible.
- (e) Allow foods to cook until done and/or an extended short time for extra browning.
- (f) For such small foods as potatoes, oysters, onion rings, etc., are more uniformly browned if the basket is lifted and shaken several times during frying. This also prevents their sticking together or to the basket.

- (g) Pastry enclosed foods should be kept submerged during frying.
- (h) Doughnuts, fritters and other foods that rise to the surface of the fat during frying should be turned over only once.
- (i) When breaded foods are prepared, strain the fat frequently.
- (j) To speed food service during rush hours, such foods as thick chops, chicken, and potatoes may be partially cooked in advance at a temperature of 325°F. For proper browning, complete frying at a higher temperature.
- (k) When finished cooking food, hang the basket on support to allow excess fat to drain off. Serve food while piping hot.
- (l) Do not salt food directly over fat. Salt or seasoning is another breakdown catalyst that shortens fat life.

NOTE: FOR MODELS WITH AUTOMATIC BASKET LIFTS. Set timer for proper frying time of product being cooked. Load basket(s) with product. Press button in center of timer knob. Baskets will lower, raise at end of the preset time.

### 4.5 Prolonging Fat Life

Your Toastmaster fry kettle and the fat used in it will give longer, more profitable service if the following instructions are observed.

- #### 4.5.1 MODELS WITH REMOVABLE FAT WELLS -
- Straining the fat and cleaning fat container.
- (a) Raise the heating elements to the intermediate position and allow to drain a few seconds, then swing to the upright position.
  - (b) Have spare fat container or pail able to contain 29 pounds of fat set in front of fry kettle.
  - (c) Locate siphon as shown on diagram and attach filter bag.
  - (d) Raise siphon pump handle to top position, then with a steady push, lower pump handle all the way down. The fat will then start siphoning from the top fat container through the filter bag into the lower fat container.
  - (e) As soon as fat has drained sufficiently from the filter bag, lift off siphon from fry kettle and remove to sink for cleaning.
  - (f) Remove fat container from fry kettle to sink for cleaning with hot water and soap.

- (g) Rinse siphon and fat container thoroughly with clear water and wipe dry.  
NOTE: This step is very important. A very small amount of soap left in the fat container will cause violent boiling and sputtering when fat is hot.
- (h) Replace fat container in fry kettle and pour strained fat from pail into fat container. If matching fat containers are used, simply place fat container of strained fat in fry kettle.

4.5.1.1 MODELS WITH FIXED FAT WELLS - Straining the fat and cleaning the fat container.

- (a) Beneath the fryer's drain valve place a vessel capable of holding half of the amount of fat contained in the well. Three vessels will be needed.
- (b) Be sure each vessel is securely covered with several thicknesses of cheesecloth allowing slack to form a pocket.
- (c) Open valve and allow fat to flow into vessel at a rate so as not to overflow the pocket in the cheesecloth. Close valve after draining about half the fat and exchange vessels and continue until well is empty.
- (d) Wipe remaining food particles from fat well into drain with a dry cloth. Close valve and set vessels aside.
- (e) Thoroughly wash fat well with soap and water. Drain into a third vessel. Rinse thoroughly to remove all traces of soap.
- (f) Wipe fat well completely dry. Water remaining in the fat well will cause violent sputtering and boiling when fat is hot.
- (g) Close drain valve and pour strained fat back into fat well.
- (h) Lower heating elements.
- (i) Reheat fat to 300° F. Add enough new fat to bring fat level to "FULL" mark on back of fat container.
- (j) Discard fat as soon as it tends to bubble excessively before food is immersed, or when gummy film collects on fry baskets or heating elements.
- (k) At least once a day cool a small amount of fat and taste to see if it has picked up any foreign flavors. If so, discard fat load, clean fat container and refill with fresh fat.

4.5.2 Revitalize Fat

Frying fat begins to break down from the first time it is used; however, the life use of good fat may be prolonged by the following. At least once a day replace 15% of fat in use with fresh fat. (The difference between "FULL" and "ADD FAT" marks represents approximately 15% of fat capacity or 4-1/2 pounds when fat is hot.) Keep fat level above top heating element at all times.

5. CLEANING

5.1 Cleaning the Fat Container - Refer to Par. 4.5.1 for cleaning the fat container.

5.2 Exterior Surfaces - Keep all surfaces of the fry kettle free of splashed grease or other foreign particles by washing with hot water and soap. Rinse and wipe off excess water. Polish with a dry soft cloth. This simple treatment not only keeps the fry kettle free of dirt and sparkling, but eliminates the danger of grease accumulation forming hard to remove stains if left too long.

5.3 Cleaning the Heating Elements - If considerable carbon has collected on the heating elements it can be burned off by operating the unit with a dry fat container at a temperature setting of 250° F. for a few minutes. Turn thermostat dial back to "OFF", then brush off loose carbon and clean the fat container.

6. IN CASE OF FIRE

FIRST - De-energize fryer at disconnect switch. This will cut off power to the heating elements and allow the fat to cool thus reducing the flash point temperature and making it easier to stop the fire.

SECOND - Immediately cover the fat container with the fryer cover and/or a heavy blanket or canvas. This will cut off oxygen to the fire.

THIRD - Play the fire extinguisher nozzle over the blanket or cover to seal off additional oxygen thus smothering the fire.

CAUTION: Do not attempt to fight a grease fire by playing the fire extinguisher nozzle directly on the burning fat. The force will cause the burning fat to be sprayed on adjoining equipment making it difficult to contain the fire. Only use a fire extinguisher filled with CO<sub>2</sub> for liquids and oils and suitable for electric powered equipment.

8. DEEP FAT FRIED FOODS COOKING GUIDE

F O O D	CONTROL SETTING	TIME IN MINUTES	C A P A C I T Y   L O A D
French Fried Potatoes One Temperature Method	375° F.	5½ to 6	6.5 pounds cut in 3/8 inch strips
French Fried Potatoes Two Temperature Method			
Blanche	325° F.	4 to 5	8 pounds cut in 3/8 inch strips
Brown	375° F.	2 to 3	10 pounds cut in 3/8 inch strips
Potato Chips	350° F.	3 to 4	4 pounds cut in thin slices
Fish Fillets	365° F.	3 to 4	20 to 24 fillets 5 x 2½ inches
Shrimp	375° F.	2 to 3	6.5 pounds
Oysters & Clams	395° F.	2 to 3	7.5 pints
Chicken			
Quartered	350° F.	10 to 13	10 servings 12 to 14 ounces each
Halved			10 servings 12 ounces each
Croquettes	365° F.	3 to 4	40 servings 2½ inch diameter
Fritters			
Fruit-Vegetable-Meat	375° F.	4 to 5	20 servings 2½ inch diameter
French Toast	325° F.	2 to 3	20 servings 2 x 4½ inches
Turnovers			
Fruit-Vegetable-Meat	375° F.	3 to 4	20 servings 4 x 2½ inches

**C. VENTILATOR FOR DEEP-FAT FRYER**

**CLEANING**

Stainless steel filters, interior surfaces, fans, ducts and other appurtenances must be cleaned at frequent intervals prior to such surfaces becoming heavily contaminated with grease or oily sludge. Flammable solvents or other flammable cleaning aids shall not be used. Metallic fibre scouring pads should not be used on stainless steel exterior surfaces. Permanent filters may be effectively cleaned in dishwasher if desirable. At the start of the cleaning process all electrical switches for the system must be in the "off" position to prevent accidental start-up of the motor and fan. When cleaning the motor, it should be unplugged from its internal plug-in connection. Care must be taken, during cleaning process not to use cleaning compounds on the fusible links.

WHEN CLEANING PROCEDURES ARE COMPLETED, ALL ELECTRICAL SWITCHES AND PLUGS SHALL BE RETURNED TO AN OPERABLE STATE, ALL ASSEMBLIES MUST BE IN PROPER OPERATING POSITION WITH DAMPERS POSITIONED FOR PROPER AIR FLOW.

**1. Fire Extinguishing Equipment.**

1.1 Approved fire extinguishing equipment shall be provided for the protection of Cooking equipment (such as fat fryers, ranges, griddles, and broilers), which may be a source of ignition of grease in the grease removal device.

**2. Duct Systems.**

2.1 **MATERIALS.** Ducts shall be constructed of and supported by steel not lighter than No. 16 Manufacturers Standard Gage or stainless steel not lighter than No. 18 Manufacturers Standard Gage, so as to comply with NFPA 96.

**2.2 INSTALLATION REQUIREMENTS FOR INTERIOR LOCATIONS.**

- (a) All seams and joints shall have a liquidtight continuous external weld.
- (b) All ducts should lead, as directly as possible, to the exterior of the building and shall be installed without forming dips or traps which might collect residues.

**3. Operating Procedures.**

3.1 Exhaust systems should be operated during all periods of cooking.

3.2 Care must be exercised not to create flash grease fires by placing solid fats on preheated cooking surfaces. Solid fats heated too rapidly can be ignited at the edges before entirely melted.

3.3 The Jenn-Air exhaust system should not be operated with fillers or dampers removed.

3.4 Instructions for manually operating the fire extinguishing system should be posted conspicuously in the kitchen and should be reviewed periodically with employees by the management.

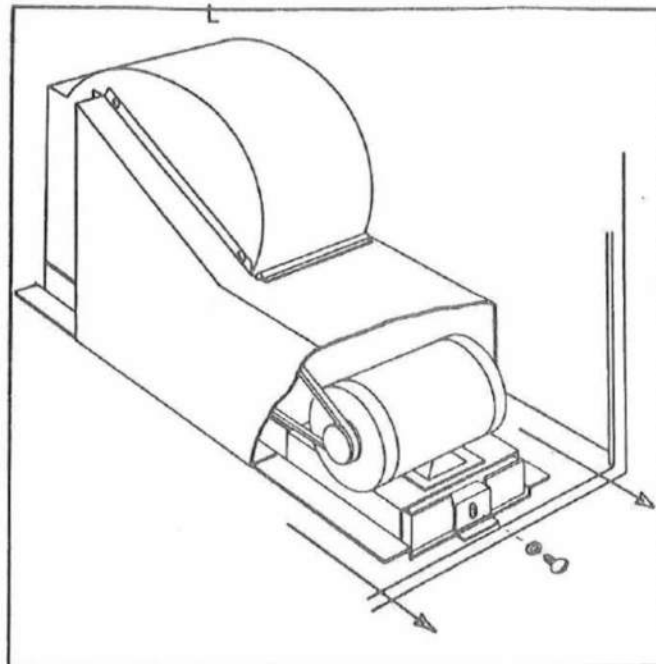

**MAINTENANCE—OPERATION**

- 1. Fan wheel, belt, motor and dampers should be inspected after three (3) months and based on these findings a periodic inspection schedule should be established. Clean as required.
- 2. The motor and fan shaft bearing housings in this unit are equipped with pre-lubricated ball bearings. These bearings will require no relubrication for normal operation.
- 3. Filters should be inspected and cleaned regularly. Dirty filters impair the operation of the unit. A removable grease tray is located on interior below ON/OFF switch mullion. This tray should be emptied regularly.
- 4. Removal of power assembly for maintenance and cleaning is accomplished simply by removing screw in retaining clip, unplugging motor and sliding complete power assembly out of unit. Removal of power assembly shroud is accomplished by removing attachment screws.
- 5. Inlet dampers—The inlet dampers of the unit are adjustable framed assemblies, which are easily removed from the unit housing for cleaning. To remove slide frame to either front or rear and lift out. Fusible firelinks are located in the inlet damper assembly. Should fire cause tripping of these links the inlet dampers will close thereby preventing fire from traveling into unit and duct work. To prevent unwanted link separation fusible firelinks should be removed if inlet damper assembly is steam cleaned or cleaned in dishwasher.

**NOTE:** All installations shall be performed in strict compliance with all applicable codes.

**JENN INDUSTRIES INC.**  
A JENN-AIR COMPANY

3035 North Shadeland Avenue • Indianapolis, Indiana 46226

**WARRANTY**

The Jenn-Air Corporation warrants this equipment to be free from defects in material and workmanship for a period of one year from date of purchase. Any units or parts proving defective within this period will be repaired or replaced at our option when returned to our factory, transportation charges prepaid. Under no circumstances will the Jenn-Air Corporation be responsible for any installation or removal cost.

**MOTOR SERVICE**

Should the motor prove defective within the one year period, it should be returned to your nearest authorized motor service station. (See the classified section of your telephone directory under the particular motor manufacturer).

**D. GREASE FILTER FOR DEEP-FAT FRYER**

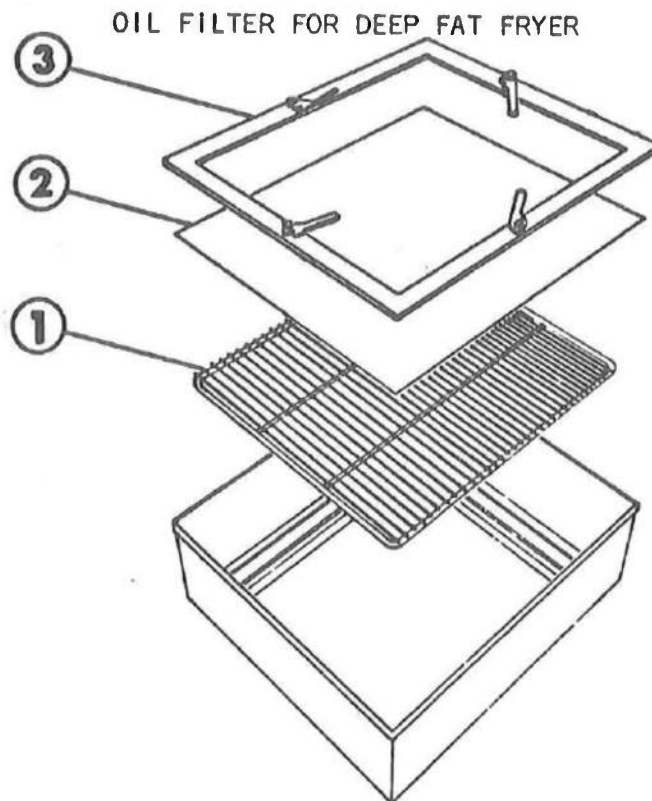

**MF 90-A SUCTION  
OPERATION INSTRUCTIONS**

1. Oil temperature at 300°-350°; USE GLOVES FOR PROTECTION.
2. Move filter to fryer. Turn fryer off.
3. Put filter switch to IN position, turn timer to start pump and insert nozzle into fryer one inch from bottom. For best results insert nozzle into a kitchen strainer placed in the oil to keep harmful sediment from filter pump and lines.
4. Vigorously whip in 16 oz. by volume of Micro Precoat into filter. Do not put filter to OUT position until this has been done.

**Optional:**

A second fryer can be filtered at the same time, if so desired, utilizing the same Micro Precoat for both batches.

**Optional:**

If acid absorbing Micro Media is used, blend in 3 oz. by volume into filter for each 35 lbs. of oil, after using precoat.

5. Put filter in OUT position (motor must be stopped to reverse) with hose nozzle in pan holster. Put timer on five minutes for recycling.
6. Lift out electric fry pot, pour content into filter, wash out pots and dry.
7. Insert pans into fryer, pump oil back using OUT position.
  - A. If additional fryers are to be filtered proceed with step-no. 4, except use 8 oz. by volume of precoat.
8. When pumping oil into last fryer, direct hose nozzle into filter when one inch of oil remains. Use hot oil to flush all sediment from bottom corners and pan walls. Return oil to fryer and use scraper to remove all impurities and particulate matter from paper. Wipe filter with dry towel. With solid shortening, hose must be drained after use.
9. Change paper when it becomes dark and scuffed in appearance.

**CONDITION OF SALE**

1. All shipments—F.O.B. Culver City, California
2. Payment terms are net 10 days. Unpaid invoices beyond terms will be subject to a 1½% service charge each month they remain unpaid. Customers sending purchase orders for the first time should enclose trade reference, otherwise first shipments will be sight draft, pro forma, or C.O.D.
3. Damaged shipments should be so noted on the incoming bill of lading. The customer will be responsible for collection of damage claims.
4. Merchandise for return to factory must be authorized by Dean Industries, Ltd. and shipped prepaid. A 15% restocking charge will prevail.
5. Unless noted to contrary, prices shown shall remain in force for 60 days.
6. Minimum factory parts order is \$10.
7. We reserve the right to amend specifications and availability without prior notice.
8. Model number and serial number of appliance must accompany all parts orders.

## **E. AUTOMATIC POTATO EXTRUDER**

### SECTION 3 OPERATION AND CLEANING

Operation is divided into four procedures. 1. The Charging Procedure which must be performed each operational day and when the FRISPO-MATIC has been idle for a long period of time. 2. The AUTO Operation Procedure, in which the FRISPO-MATIC dispenses all of the potato pieces and then charges itself for the next cycle. 3. The SINGLE Operation Procedure in which the FRISPO-MATIC dispenses one portion of potato pieces. When all of the potato is used, the FRISPO-MATIC will then charge itself for the next cycle. 4. The Operation Checkout which contains procedures for checking and adjusting the FRISPO-MATIC.

#### WARNING

Failure to clean the FRISPO-MATIC daily could result in food poisoning or machine damage.

CLEANING is divided into two procedures. 1. The Daily Cleaning Procedure which must be performed each day. 2. The Periodic Major Cleaning Procedure which is to be performed as often as local conditions may require.

#### OPERATION

##### Charging Procedure

1. Place POWER switch [1] at ON. If Frispos light does not illuminate, refer to Section 6.
2. Remove front door [12].
3. Lift cutter sleeve [5] and remove cutter [6].
4. Rotate slicer [11] counterclockwise and remove slicer.
5. Lift and remove deflector plate [10].
6. Remove cylinder [13].
7. Install diaphragm [9] on piston [4].
8. Slide piston off shaft [7] and onto charging pin [8].
9. With side opening [2] toward top of cylinder [13], place the cylinder over

piston [4] and firmly press cylinder onto piston.

10. Install door [12].
11. Check that red REFILL light [3] is ON.

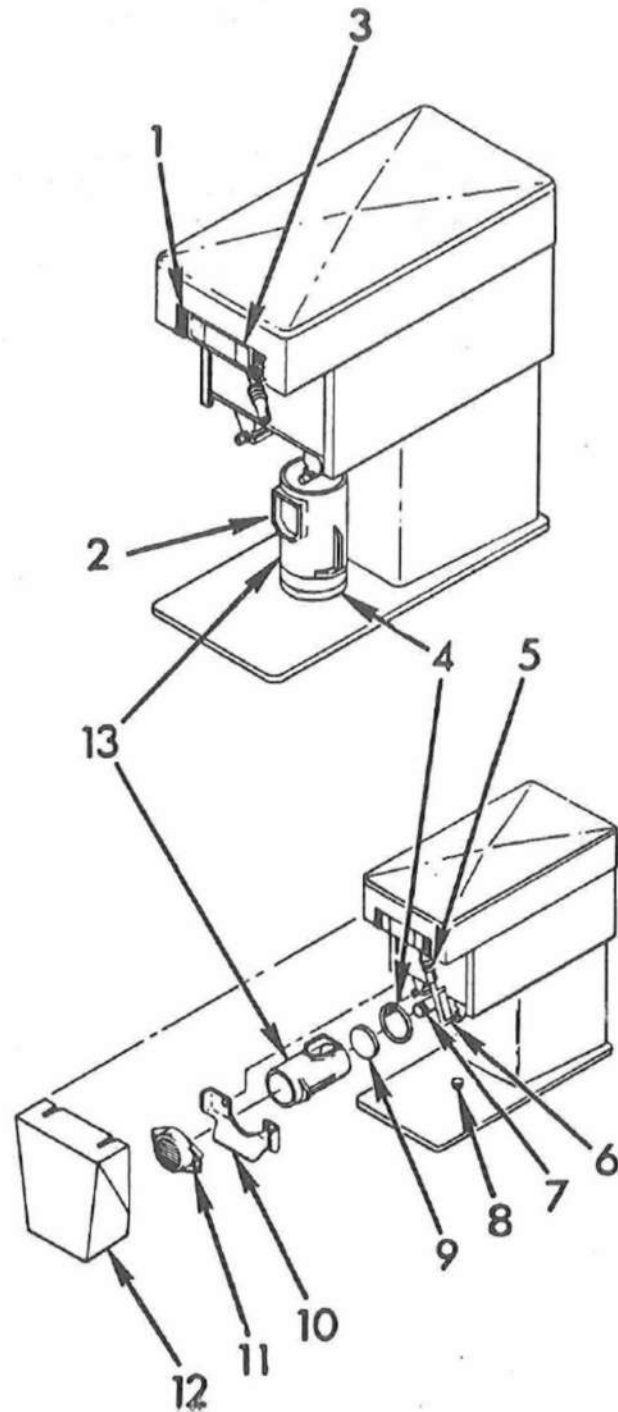

If red REFILL light [4] is off, go to Step 15.

For optimum french fry quality, do not refill hopper with FRISPO French Fry Mix until red REFILL light [4] is on.

12. Remove top cover [1].
13. Fill hopper [2] with French Fry Mix.
14. Install cover [1].
15. When green READY light [6] is on, place PORTION CONTROL switch [3] at AUTO and depress push-plate [5].

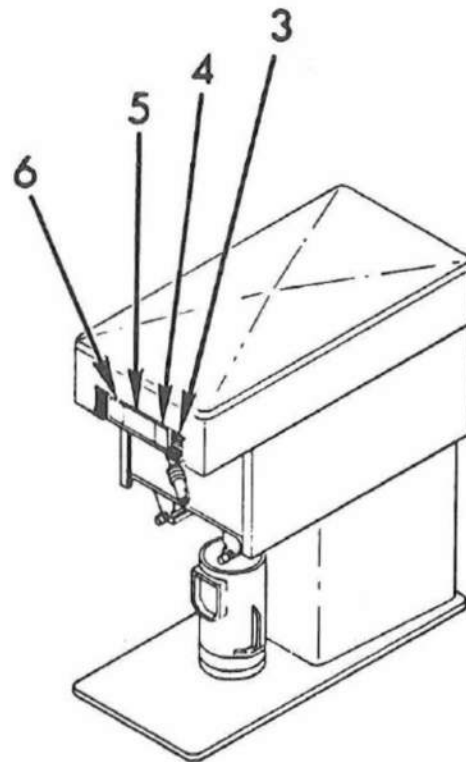
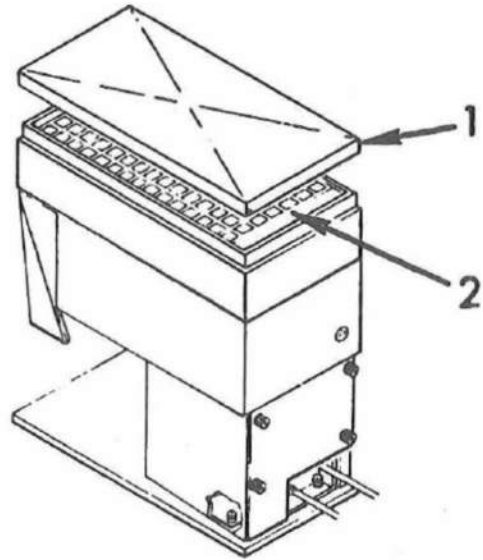

16. After one minute, remove door [10].
17. Lift and remove cylinder [12] and piston/diaphragm [11].
18. Install piston/diaphragm [11] onto shaft [6].
19. Install cylinder [12] and deflector plate [8].
20. Install slicer [9] and rotate slicer clockwise.
21. Install cutter [7] and door [10].
22. When green READY light [2] is on, FRISPO-MATIC is ready to operate.

#### AUTO Operation Procedure

1. Place POWER switch [1] at ON. Check that FRISPOS light [3] is on.

If FRISPOS light [3] is off, refer to Section 6.

2. Place transfer tray under deflector plate [8].

#### WARNING

Hands must be kept away from deflector plate [8] while FRISPO-MATIC is operating.

If red REFILL light [4] is on, perform Steps 12 through 14 of Charging Procedure.

3. When green READY light [2] is on, place PORTION CONTROL switch [5] at AUTO and depress push-plate [3].

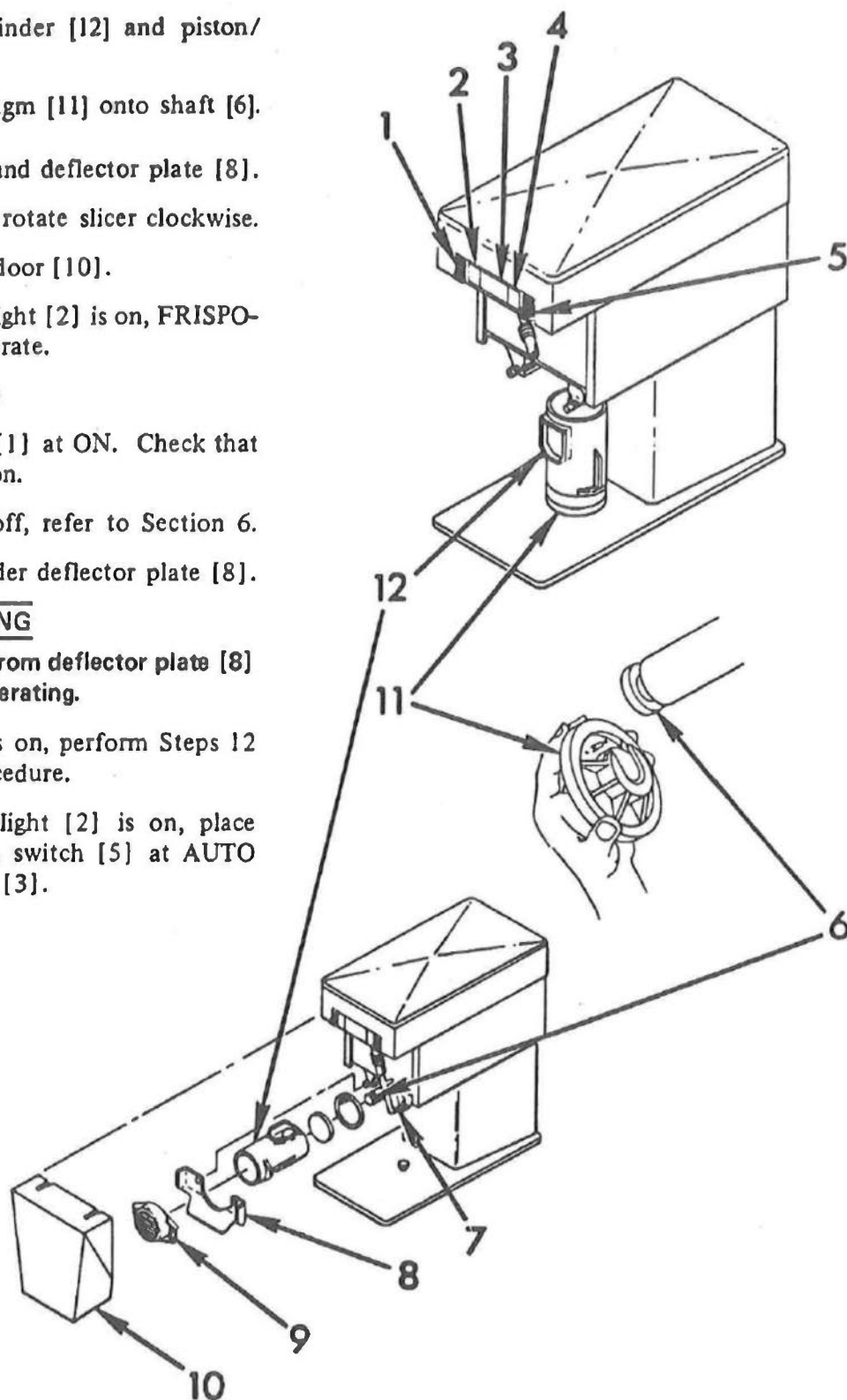

4. Move transfer tray slowly to distribute potato pieces evenly.
5. Place potato pieces into submerged fry basket.
6. After the potato pieces are immersed in oil, shake basket with up and down motion.

Fry potato pieces in approximately 350°F oil.

7. After 1½ minutes, remove basket from fryer, shake basket briskly and place FRISPOS under a red heat lamp.
8. Check FRISPOS for sticking and breaking.

If FRISPOS stick, or break excessively perform Operation Checkout and/or refer to Section 6.

Fry potato pieces in approximately 350°F oil.

7. After 1-1/2 to 2 minutes, remove basket from fryer, shake basket briskly and place FRISPOS under a red heat lamp.
8. Check FRISPOS for sticking and breaking.

If FRISPOS stick, perform Operation Checkout and/or refer to Section 6.

If FRISPOS break into pieces less than 2 inches in length, perform Operation Checkout and/or refer to Section 6.

#### SINGLE Operation Procedure

1. Place POWER switch [1] at ON. Check that FRISPOS light [3] is on.

If FRISPOS light [3] is off, refer to Section 6.

2. Place transfer tray under deflector plate [6].

#### WARNING

Hands must be kept away from deflector plate [6] while FRISPO-MATIC is operating.

If red REFILL light [4] is on, refill product hopper.

3. When green READY light [2] is on, place PORTION CONTROL switch [5] at SINGLE and quickly depress and release push-plate [3].
4. Move transfer tray slowly to distribute potato pieces evenly.
5. Place potato pieces into submerged fry basket.
6. After the potato pieces are immersed in oil, shake basket with up and down motion.

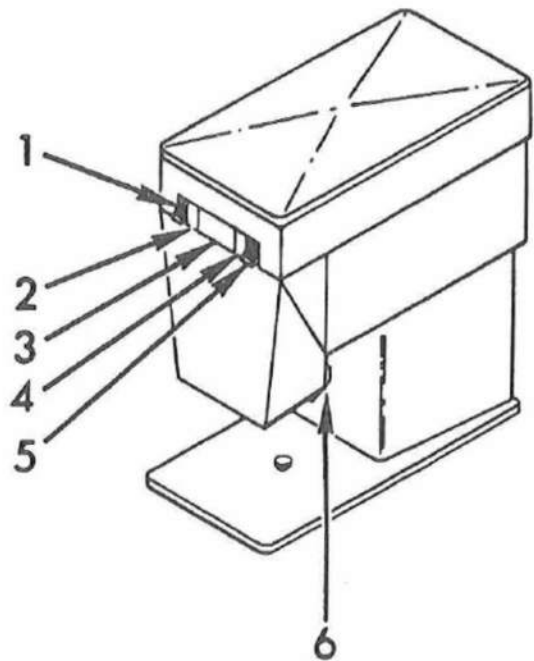

## Operation Checkout

### Tools:

Thermometer, °F or °C

Scale, gram

Graduated cylinder, 500 ml.

2 containers, greater than 1-pint capacity

1. Place POWER switch [1] at OFF.
  2. Remove front door [11].
  3. Lift cutter sleeve [5] and remove cutter [6].
  4. Rotate slicer [10] counterclockwise and remove slicer.
  5. Lift and remove deflector plate [9].
  6. Remove cylinder [8] and piston [7].
  7. Place one container under nozzle opening [12] and other container under dry product opening [13].
  8. Install door [11] and place POWER switch [1] at ON.
- If red REFILL light [4] is on, perform Steps 12 through 14 of Charging Procedure.
9. When green READY light [2] is on, depress push-plate [3].
  10. When FRISPO-MATIC stops operating, remove containers and place thermometer in the water container. Check that temperature of water is  $145^{\circ} \pm 2^{\circ}\text{F}$  ( $62^{\circ} \pm 1^{\circ}\text{C}$ ).

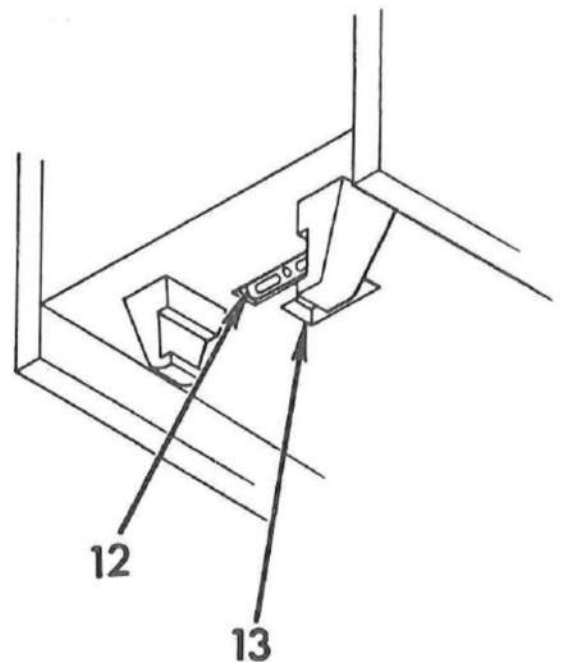
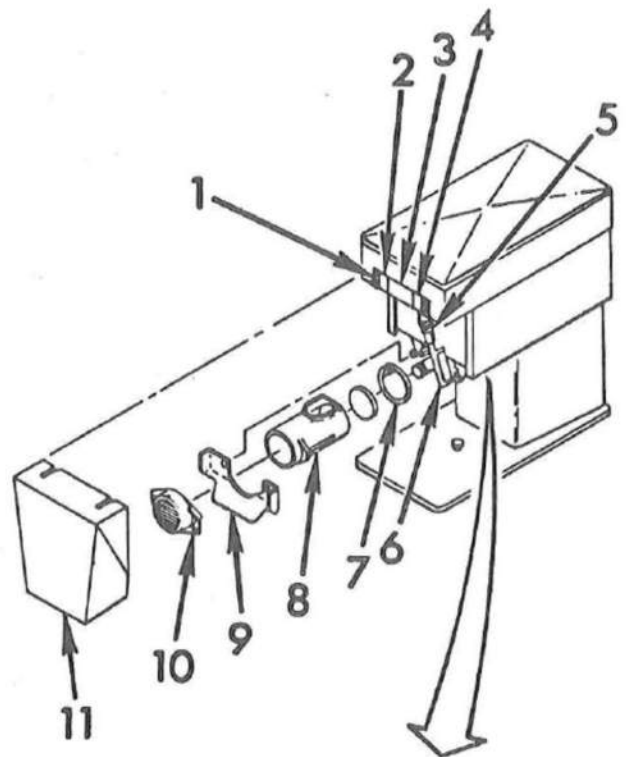

If water temperature is below 143°F (61°C), remove thumb screws [1] and lower back panel [2]. Slightly turn adjusting screw [3] clockwise, and recheck temperature. Install panel and screws.

If water temperature is above 147°F (63°C), remove thumb screws [1] and lower back panel [2]. Slightly turn adjusting screw [3] counterclockwise and recheck temperature. Install panel and screws.

11. Pour contents of container into graduated cylinder. Check that water volume is  $450 \pm 3$  ml.

One full turn of high probe [4] equals 8 ml.

If water volume is below 447 ml., remove thumb screws [1] and lower back panel [2]. Rotate high probe [4] counterclockwise and recheck volume.

If water volume is above 453 ml., remove thumb screws [1] and lower back panel [2]. Rotate high probe [4] clockwise and recheck volume. Install panel and screws.

12. Place contents of other container on gram scale. Check weight of potato product mix.

If weight of mix is less than 175 grams, perform Daily Cleaning Procedure.

If weight of concentrate is greater than 195 grams, (as may happen through mishandling of product) French Fry Mix should be replaced. Go to Step 13.

If any of previous checks indicate machine out of tolerance, repeat Steps 9 through 12.

If the FRISPO-MATIC is to be operated, go to Charging Procedure.

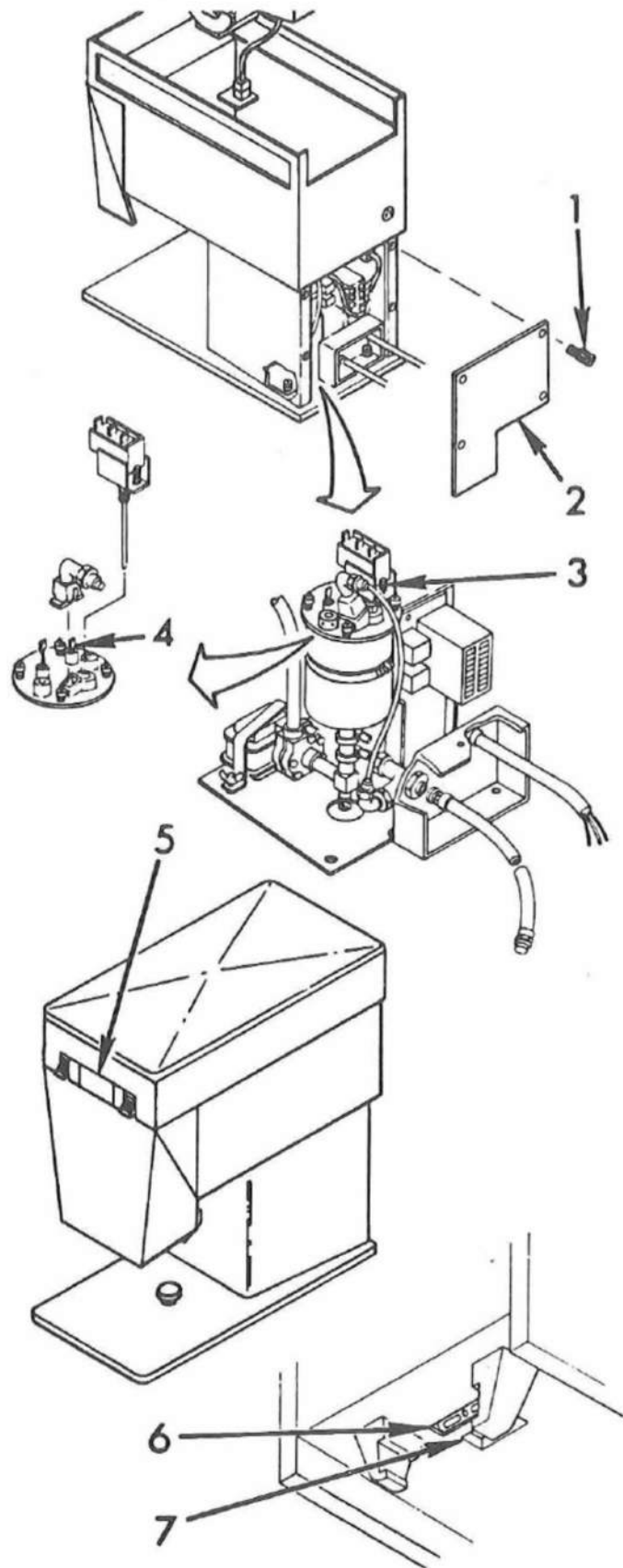

## CLEANING

### Daily Cleaning

#### Supplies:

Clean damp cloth  
Soap  
Sanitizing solution

#### WARNING

Failure to clean the FRISPO-MATIC could cause food poisoning or machine damage.

1. Place POWER switch [2] at ON.
2. Place transfer tray [4] under the deflector plate [1].

#### WARNING

Hands must be kept away from deflector plate [1] while FRISPO-MATIC is operating.

If red REFILL light [3] is on, perform Steps 12 through 14 of Charging Procedure.

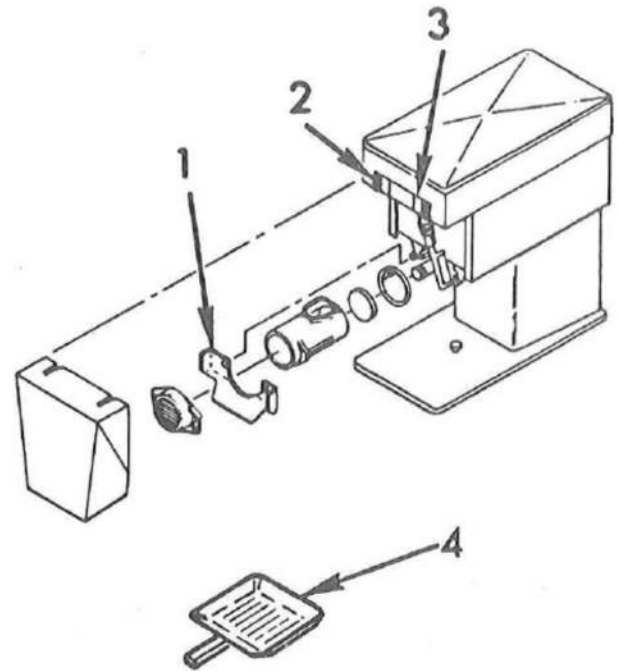

Read Steps 3 and 4 before proceeding.

3. When green READY light [2] is on, place PORTION CONTROL switch [4] at AUTO and depress push-plate [3].
4. When potato pieces stop falling, place POWER switch [1] at OFF.
5. Remove door [13].
6. Lift cutter sleeve [5] and remove cutter [6].
7. Rotate slicer [12] counterclockwise and remove slicer.
8. Lift and remove deflector plate [11].
9. Remove cylinder [10] and slide piston [8] from shaft [7].
10. Remove remainder of rehydrated potato product. Remove diaphragm [9] from piston [8].

If performing Periodic Major Cleaning Procedure, go to Page 3-9.

11. Wipe clean all surfaces of the FRISPO-MATIC with a clean damp cloth. Wipe dry.

**CAUTION**

Do not use abrasives on rubber, plastic or stainless steel surfaces.

Do not use solvents on plastic parts.

Do not place parts in automatic dishwasher.

Hard to remove dry product may be softened by soaking parts for a short time in warm water.

12. Wash all removed parts in warm, soapy water. Rinse parts in clear, clean, potable water. Submerge parts in sanitizing solution and allow parts to air dry.

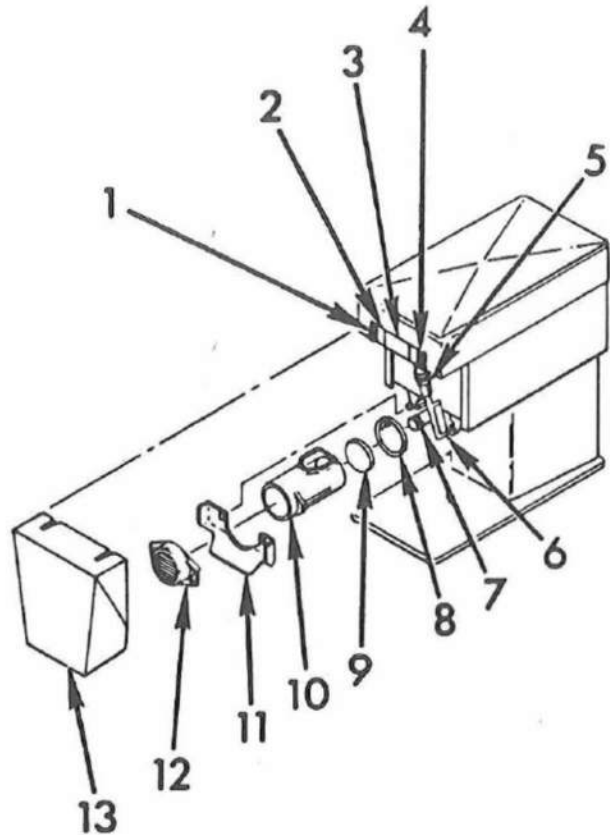

13. Check shaft [6] and area around nozzle discharge and dry product discharge for dirt and product buildup. Wipe clean as required.

Do not reassemble (steps 14 through 17) until machine has been charged.

14. Install diaphragm [3] on piston [7] and install piston on shaft [6].
15. Install cylinder [2] and deflector plate [8].
16. Install slicer [1] and rotate slicer clockwise.
17. Lift cutter sleeve [4], install cutter [5], and lower sleeve.

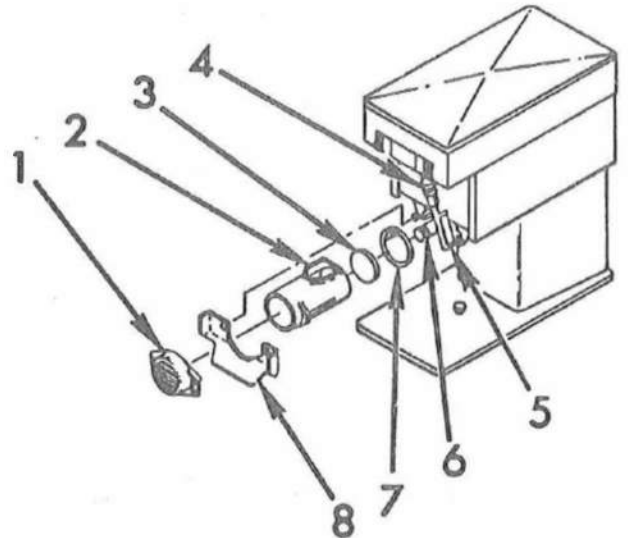

**Periodic Major Cleaning Procedure (as local conditions require)**

Supplies:

Clean container, 3-5 gallon capacity

1. Perform Steps 1 through 10 of Daily Cleaning Procedure.
2. Disconnect power cord [14].
3. Lift and remove top cover [9], top band [10], and hopper screen [11].

**CAUTION**

Do not grasp wires when disconnecting plug [13].

4. Lift hopper assembly [12] up and to the rear of the FRISPO-MATIC. Grasp upper half of plug [13] and disconnect plug.
5. Place contents of hopper assembly [12] into container.

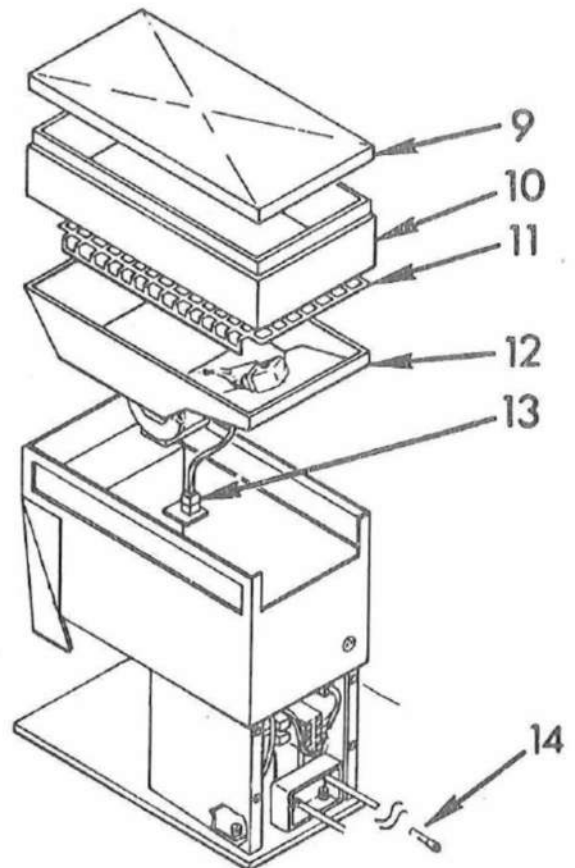

6. Remove following components from hopper assembly [4]:

- Wing nuts [1]
- Meter hopper end plate [2]
- Meter drive assembly [6]
- Meter rotor [3]
- Meter hopper end plate [5]

7. Wipe clean all surfaces of the FRISPO-MATIC with a clean damp cloth. Wipe dry.

**CAUTION**

Do not use abrasives on rubber, plastic or stainless steel surfaces.

Do not use solvents on plastic parts.

Do not place parts in automatic dishwasher.

Do not submerge meter drive assembly [6]. Damage to assembly will result.

Hard to remove dry product may be softened by soaking parts for a short time in warm water.

8. Wash all removed parts in warm, soapy water. Rinse parts in clean, clear, potable water. Submerge parts in sanitizing solution and allow parts to air dry.
9. Install end plate [5] and rotor [3] onto motor drive assembly [6].
10. Invert hopper assembly [4] and install drive assembly [6] onto hopper assembly.
11. Install end plate [2] and wing nuts [1].

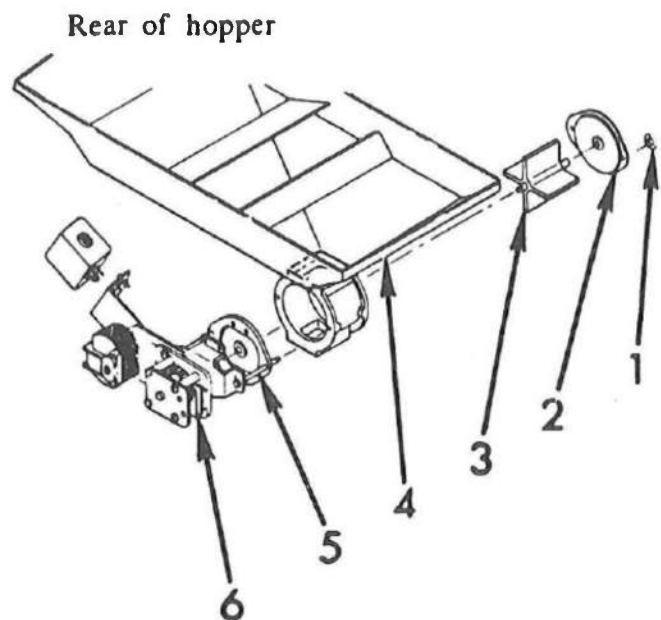

12. Remove thumb screws [3] and disconnect nozzle [2] from tubing [1].
13. Remove thumb screws [5] and lower back panel [6].
14. Remove thumb nuts [7].
15. Disconnect electrical connector [4].
16. Close shutoff valve.
17. Disconnect fill line [9] from water inlet line [8].
18. Remove water system assembly [11] and place assembly over drain.
19. Remove drain screw [10]. When all water has drained, install drain screw.

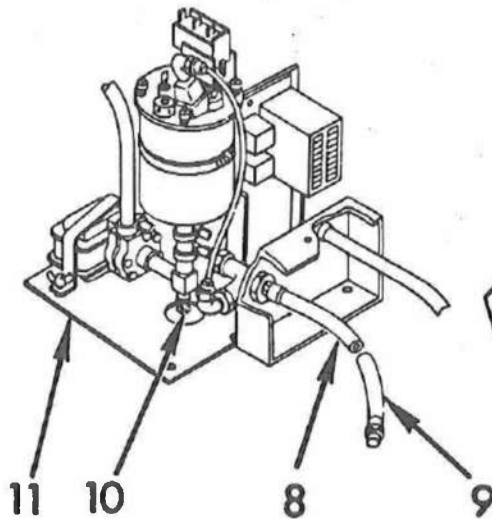
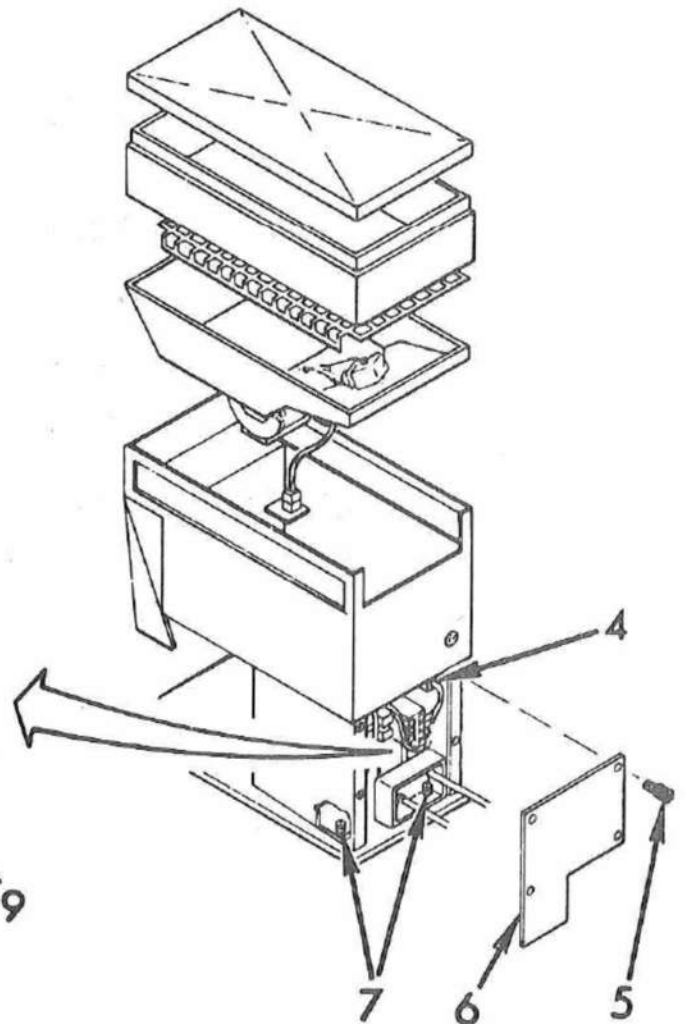
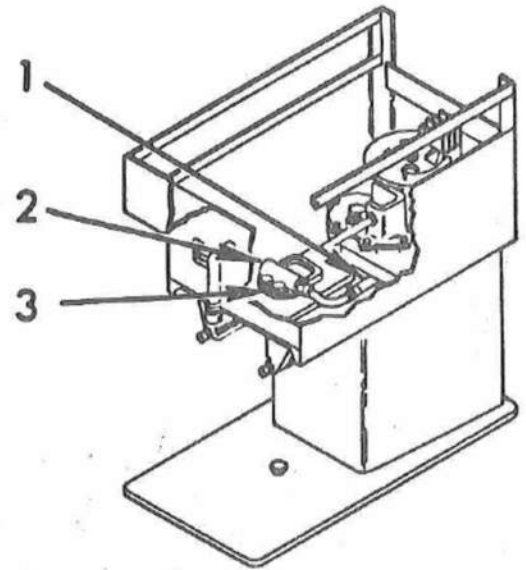

20. Disconnect fill line adapter [3].
21. Remove knurled nuts [1] and lift cap [2] from water tank [17].
22. Check the following components for traces of scale and rust:
  - High level probe [21]
  - Low level probe [19]
  - Heating element [20]
  - Thermostat sensing element [22]

If scale and rust buildup are present, place cap [2] on water tank [17] and install knurled nuts [1]. Perform Steps 14 through 60 of Descaling Procedure in Section 7. Go to Step 44.

23. Disconnect knurled fittings [4, 9] with hose [5] attached.
24. Remove wing nuts [15] and pump band [16].
25. Loosen hose clamps [6]. Rotate pump [13] upward and disconnect hose [8] from nipple [7]. Remove pump.
26. Loosen remaining hose clamp [10] and disconnect hoses [8, 18].
27. Remove pump thumb screws [12] and pump housing [11] from pump [13].

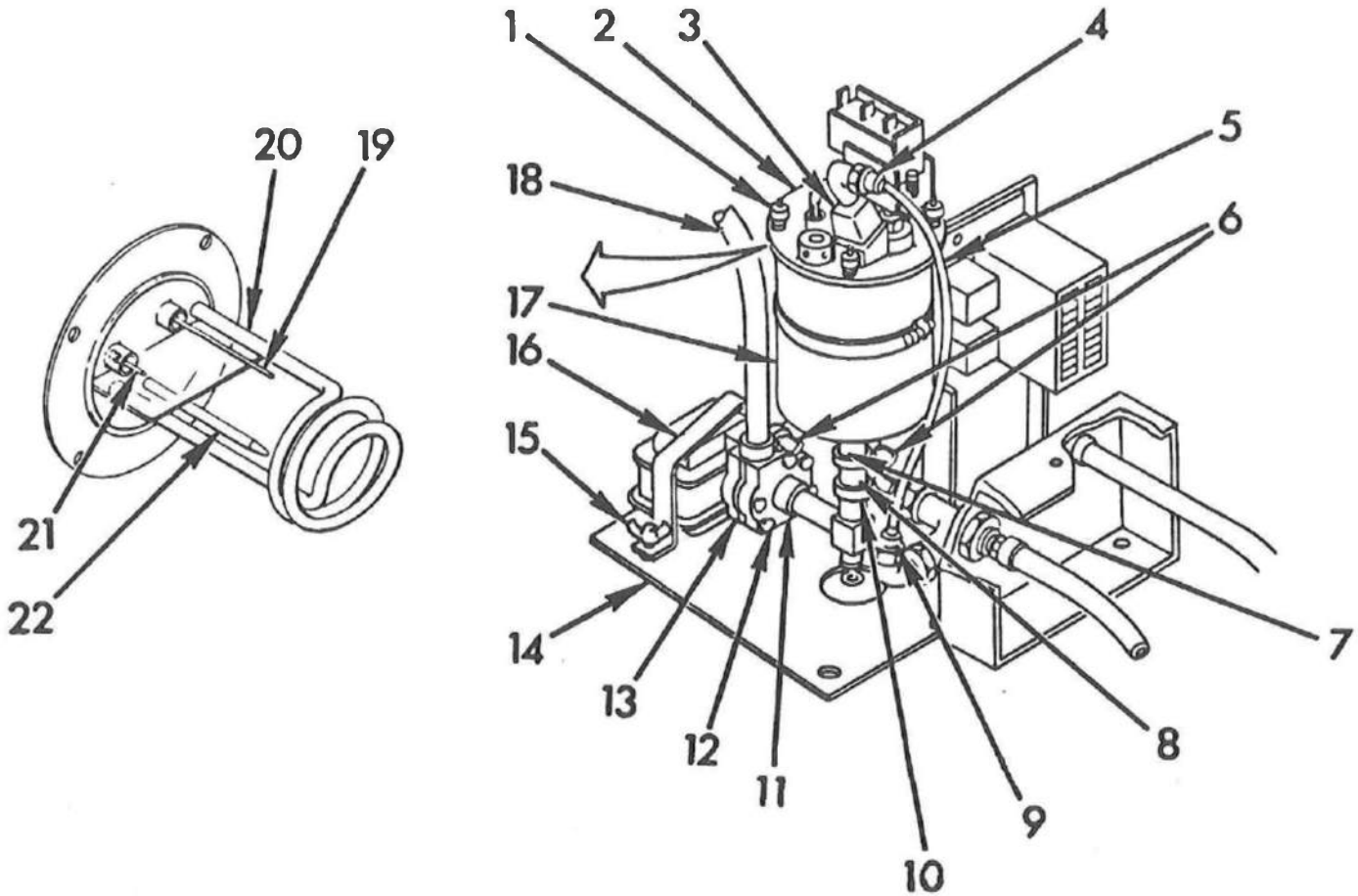

### CAUTION

Do not submerge heater tank [17], cap [2] or pump [13] in water or sanitizing solution. Damage to electrical components will result.

28. Clean all water contact areas.
29. Install pump housing [11] onto pump [13]. Install thumb screws [12].
30. Connect hoses [8,18] and tighten hose clamp [10].
31. Connect hose [8] to nipple [7] and rotate pump [13] downward into installed position.
32. Install pump band [16] and wing nuts [15].
33. Tighten hose clamps [6].
34. Connect hose [5] to knurled fittings [4,9] and connect fittings.
35. Place cap [2] on heater assembly [17] and install knurled nuts [1].
36. Connect fill line adapter [3].

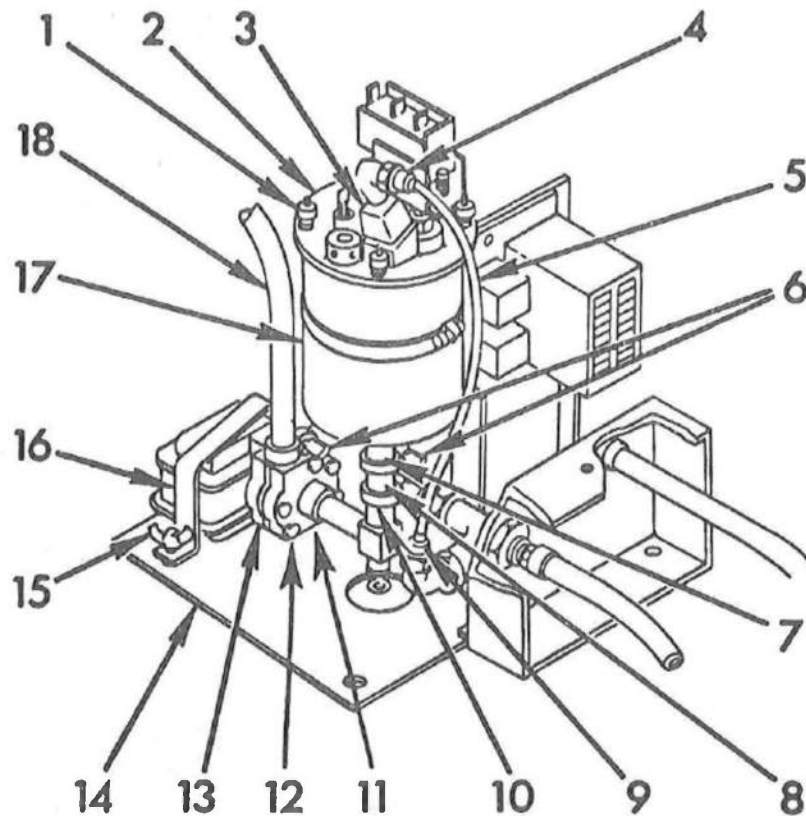

37. Install water system assembly [1].
38. Connect water inlet line [4] to fill line [2].
39. Open shutoff valve and check connections for leaks.

**CAUTION**

If connections leak, close shutoff valve and repair leaks before continuing procedure.

40. Place tubing [6] through slot [5] and push nozzle [3] into tubing.
41. Place nozzle at installed position and install thumb screws [7].

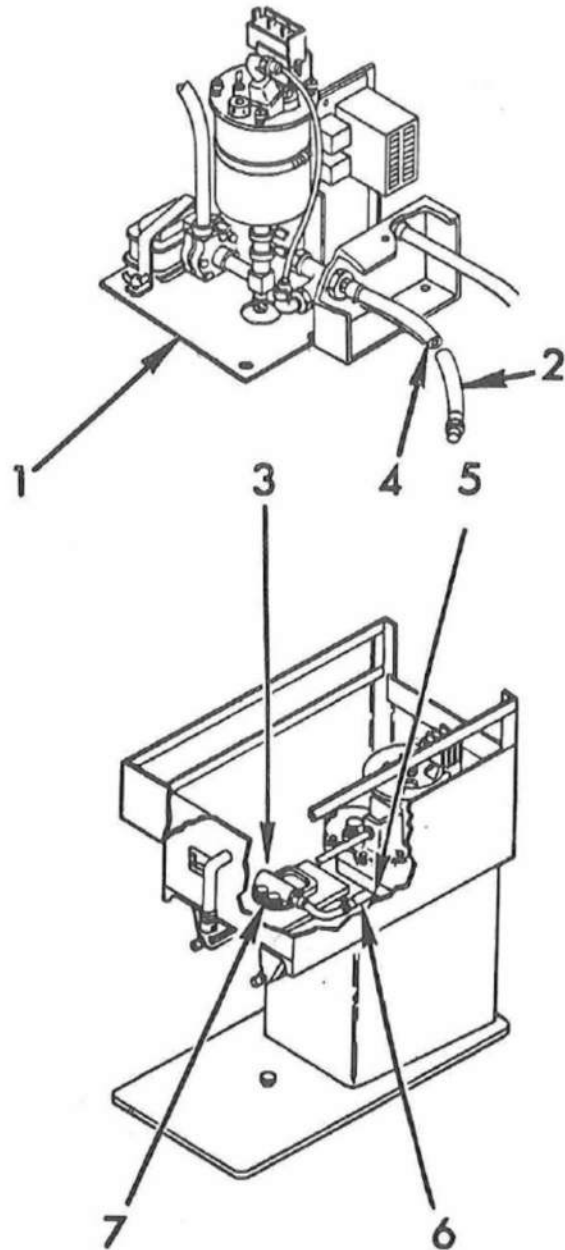

42. Install thumb nuts [10].
43. Connect electrical plug [6].
44. Install hopper assembly [4], hopper screen [3] and top band [2].
45. Connect electrical plug [5].

Check water volume and temperature as described in Section 2.

46. Place contents of 3-5 gallon container into hopper assembly [4].

If FRISPO-MATIC is to be operated, go to Charging Procedure.

47. Install top cover [1].
48. Place lower back panel [9] at installed position and install thumb screws [8].
49. Connect power cord [7].
50. Perform Steps 11 through 17 of Daily Cleaning Procedure.

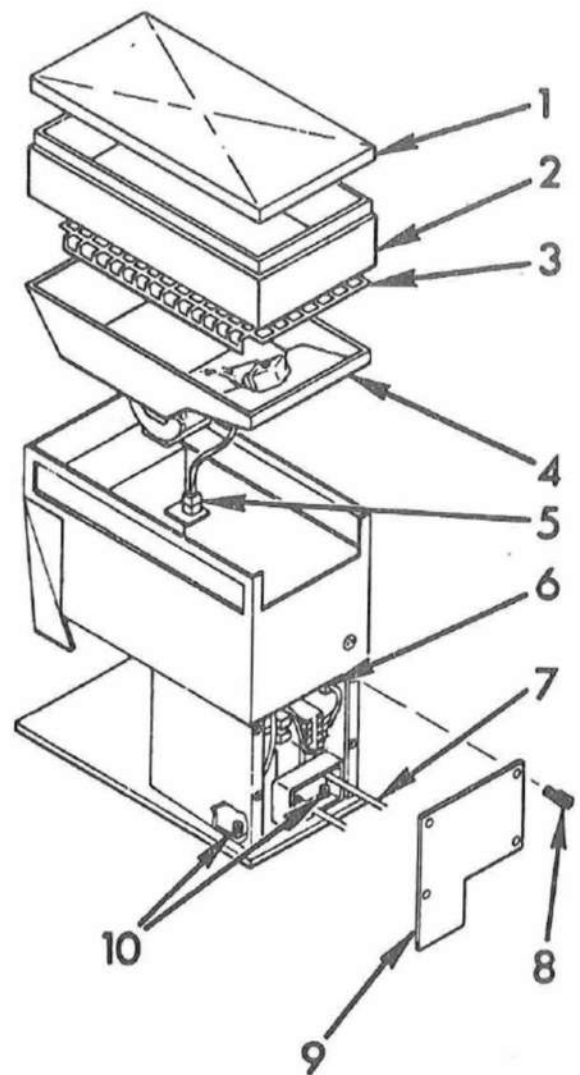

**F. HAND OPERATED POTATO EXTRUDER**

# Frispo-ette . . .

## French Fries Machine

Beautifully designed and simple to operate.

### Compact:

38cm deep x 24cm wide x 88cm high. Takes up very little space and is light enough to be moved by one person. Ideal for low or high volume shops.

### Simple to Operate:

Simple 6-step operation. From dry product to hot, crispy french fries in less than 10 minutes. By using 3 cylinders it is possible to prepare 720 portions per hour.

One cylinder produces 24 servings.

### Easy Installation:

No direct water hook-up is required. The Frispo-ette machine is hand operated and requires no electrical outlet. Ideal for **any** foodservice operation.

### Sanitary:

The key components of the Frispo-ette French Fry Machine are easily removed for cleaning.

### Reliable and Safe:

Hand operated machine with a minimum of moving parts makes Frispo-ette French Fries Machine reliable and safe to operate.

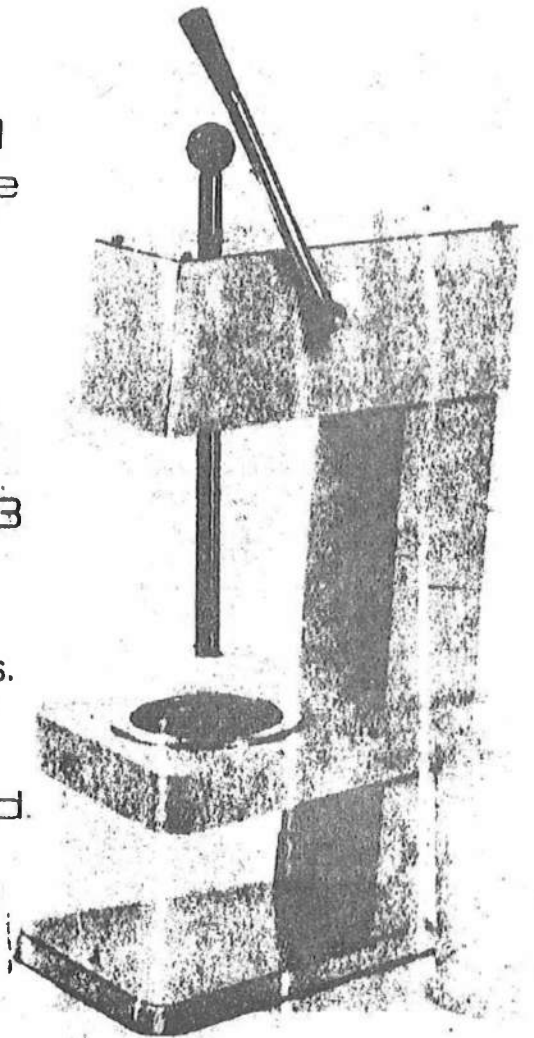

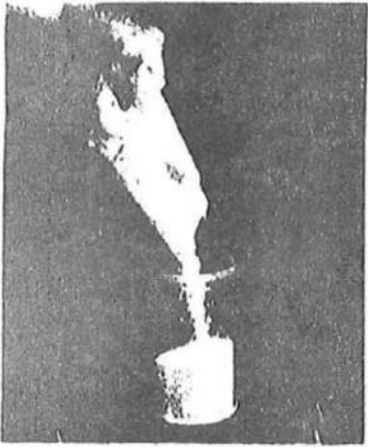

Fig. 1

## Directions

1. Place plastic cap on bottom of cylinder and pour complete bag of Frispo-ette Potato Mix into cylinder.  
(Fig. 1)

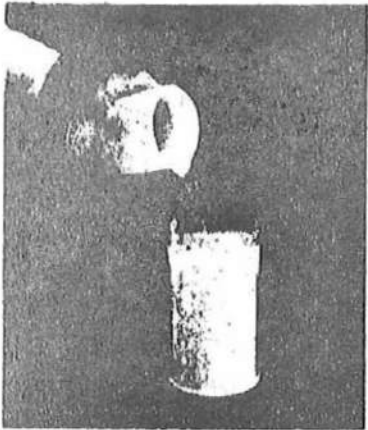

Fig. 2

2. Measure 1165 ml of cool tap water  $10-38^{\circ}\text{C}$  ( $50-100^{\circ}\text{F}$ ) and pour into center of cylinder as rapidly as possible. Gently shake cylinder to wet top of potato mix. No stirring required. Allow to stand 5 minutes.  
(Fig. 2)

3. Remove plastic cap from bottom of cylinder and place cylinder onto Frispo-ette machine.  
(Fig. 3)



Fig. 3

4. Hold transfer tray approximately 2 inches below slicer and quickly pull dispenser lever all the way down. Allow lever to return to raised position slowly.

**Do not push lever up.**  
One pull dispenses one serving.  
(Fig. 4)

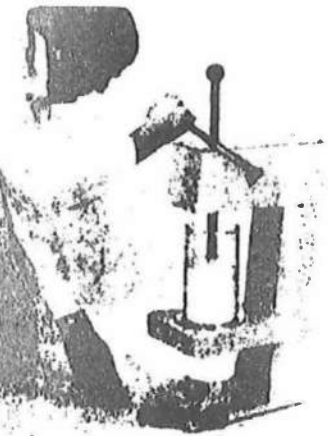

Fig. 4

5. Lower empty fry-basket into hot oil, then slide french fries into submerged fry-basket by tilting transfer tray so that french fries roll off **parallel** to lower edge of tray.

6. Fry for 90 seconds at  $175^{\circ}\text{C}$  ( $350^{\circ}\text{F}$ )

**G. TILT FRY/BRAISING PAN**

## GROEN

### TILT FRY/BRAISING PAN

#### SECTION I

##### A - OPERATING INSTRUCTIONS

1. CHECK that electric power supply is in "ON" position.
2. Turn the unit "on", set the thermostat dial to the desired temperature - 150° - 400°F. The pan will heat to the set temperature and automatically maintain it. Red light will indicate when heating elements are on, and will normally cycle on and off. As the pan cycles on and off, the contactors will make a clicking sound once during the cycle.
3. To turn the pan "off", turn the thermostat dial to the "off" position.
4. For best frying/braising results, pan should be preheated before product is put into pan. (Approximately 15 minutes.)
5. An approximate setting of 210 or less will slowly heat or simmer an item. With the cover down, moisture loss will be held to a minimum. Higher settings will cook more rapidly and will tend to drive off moisture, especially with the cover up. The thermostat may be adjusted to cook the product exactly as required, high or low or any setting between.
6. The braising pan may be used to prepare many items start to finish in the pan, including sauces, swiss steaks, pot roasts, stews, sauteed items, etc. The pan is suitable for high volume grill work such as frying bacon, sausage, hamburgers, hotcakes and similar items including eggs, both fried or scrambled. Additionally, the braising pan is widely used to prepare various types of barbecue sauces, spaghetti sauces, gravies, chop suey, potato salad, etc.
7. For removal or draining of grease from the product, the pan may be tilted slightly and excess grease may be removed.
8. Chops may be easily prepared in the pan. The chop should be browned or seared quickly on both sides, the heat should be turned down and the cover may be closed to complete the preparation.
9. The cover vent may be opened to allow excess steam or vapor to escape. For long simmering operations, the vent may be closed at the operators option.
10. To check cooking progress with cover in closed position, grasp plastic part of vent handle, lift slightly and move quickly to either side. Grasp cover handle at any point and raise quickly. Cover will be automatically maintained in an open position.

##### B - GENERAL CLEANING INSTRUCTIONS

Suggested Tools: Cleaner, such as Klenzade HC8 or HC10 or comparable product.  
One short handled gong brush.  
Liquid chlorine disinfectant.

IMPORTANT: 1. Clean as soon as possible after cooking.  
2. Measure all cleaning and disinfecting material EVERY TIME you clean.

PROCEDURE: 1. Flush pan thoroughly with luke warm water and drain to remove all loose soil.  
2. Flush and clean all parts soiled by foods, checking underside of covers, body, etc.  
3. As required, clean the outside of the unit thoroughly using the solution from the pan and rinse carefully.  
4. Flush with water. NOTE: AVOID SPRAYING ELECTRICAL CONTROLS AND ELECTRICAL CONNECTIONS.

##### ADDITIONAL PROCEDURES IF REQUIRED

5. Best sanitation practice recommends sanitation of each piece of equipment prior to use by flushing thoroughly with a 200 p.p.m. solution of the above liquid chlorine disinfectant.
6. To reduce water spotting caused by mineral deposits or film due to hard water and certain food residues, the following procedure may be performed as required.
  - a. Kettle must be clean. Using a deliming agent (such as Klenzade Ster-Kleen) and following the manufacturers suggested solution strength, thoroughly brush and clean inside and outside of unit. Drain, rinse well and allow to dry or proceed with Step No. 5 if required.

**IMPORTANT:** Never use steel wool, metal sponges, or harsh scouring powders. They may scratch the equipment surface and make the cleaning job increasingly difficult, as well as ruin the general appearance. These minute scratches can provide a home for bacteria, which, although invisible to the naked eye, can collect and develop rapidly, causing contamination of food. If especially difficult cleaning problems persist, contact your cleaning product representative for assistance. He has a trained technical staff with complete laboratory facilities to serve you.

**NOTE:** The above are general cleaning instructions only.

### C - CONTROLS

Pan is provided with a thermostatic temperature control, cover and actuator and tilt mechanism.

1. **THERMOSTAT** - The thermostat is a "break circuit on temperature rise" type control. When the thermostat switch is closed, power is supplied to the heater elements. When the temperature of the pan reaches the set temperature on the dial of the thermostat, the thermostat switch opens and breaks the electrical circuit to the heaters. When the thermostat again calls for heat, the cycle will automatically be repeated. No additional attention is required by the operator.
2. **HI-LIMIT THERMOSTAT** - The high limit thermostat is designed to interrupt the heat cycle if the pan temperature exceeds 425°F. It will automatically reset as it cools.
3. **ELECTRIC HEATER ELEMENTS** - The electric heater elements are designed to operate at the voltage stamped on the nameplate. The elements are clamped to the pan bottom and protected by a cover plate.

## SECTION II

### A - MAINTENANCE

1. Power should be disconnected before servicing.
2. The entire unit should be inspected and cleaned periodically. The period of time between cleanings will vary, depending upon the operating conditions.
3. In the event the controls require cleaning, care must be taken not to get moisture in the controls. Electric controls should not be cleaned or sprayed with water.
4. The pan should be cleaned after each use with a soap solution or commercial cleaner. Further, the exterior pan may be polished with a recognized stainless steel cleaner.
5. Steel wool is NOT recommended for cleaning any surface of the pan. Particles of steel wool may become imbedded in the surface causing corrosion and pitting.
6. Approximately twice a year it is recommended that a service man check and service the pan. There are grease fittings provided on the trunnions. A high temperature grease should be used and also applied to the open gears. Wires and connections should be checked for soundness.
7. Inside of console housing should be cleaned during service checks.
8. If tilt mechanism does not move smoothly, gears should be checked for foreign materials, lubrication and/or possibly alignment. (FPC and MW/FPC)

### B - TROUBLE SHOOTING

This section will describe some difficulties that may be encountered. A wiring diagram is furnished in the control housing of the unit. The wiring of controls may be checked against this diagram.

1. **PAN WILL NOT HEAT.**
  - a. **Pilot light out.**
    1. Verify that electrical power is on.
    2. Check for loose or broken wire.
    3. Check for defective thermostat.
    4. On 480 volt pan only, control circuit is fused.
  - b. **Pilot light on.**
    1. Heater elements burned or shorted out.
2. **THERMOSTAT WILL NOT SHUT OFF THE HEATERS WHEN PRODUCT REACHES DESIRED TEMPERATURE.**
  - a. Set Thermostat lower.
  - b. Thermostat may be inoperative. (It is recommended the entire thermostat be replaced if damaged or inoperative.)

**H. INSULATED HOT FOOD CABINET**



# CRES-COR

CRESCENT METAL PRODUCTS INC. 12711 TAFT CLEVELAND OHIO 44108

H-138-1834	FL-1470
Rev. 4 (10-77)	

## OPERATING AND MAINTENANCE INSTRUCTIONS

Model H-138-1834 Series Insulated Hot Cabinets  
with HU-18-671-11 and -12 Hot Units



"LIFT-OUT" TUNNEL

"LIFT-OUT"  
CORRUGATED  
INSERTS

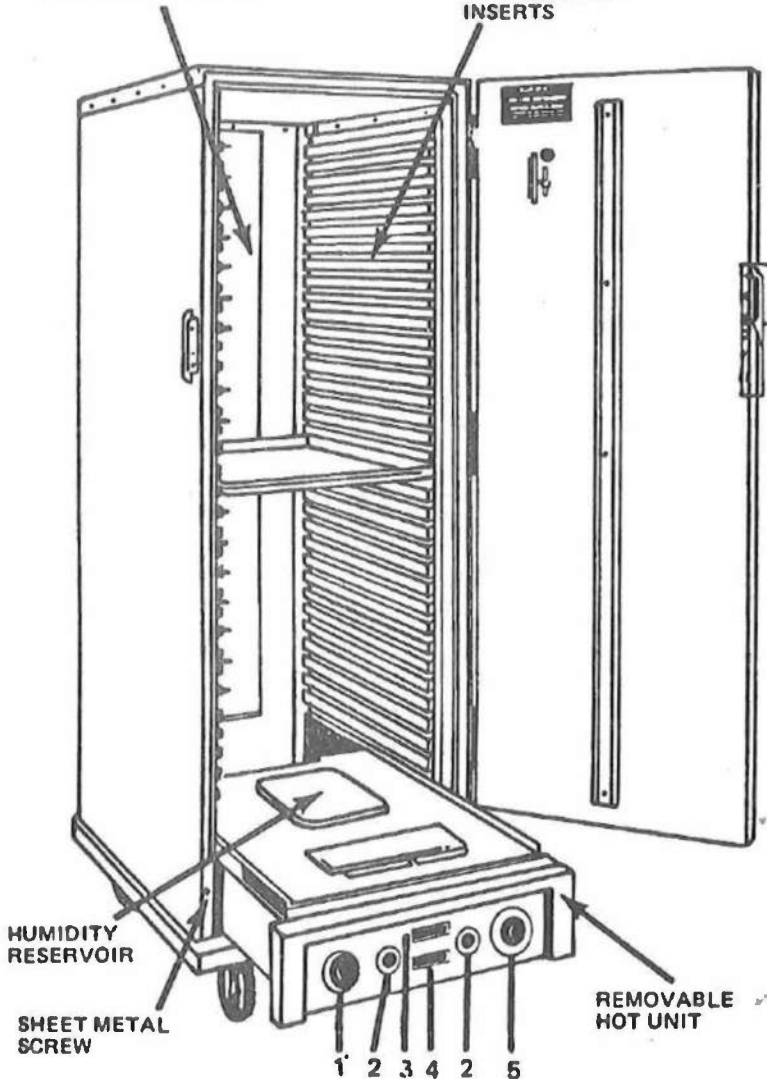

**CONTROL PANEL**  
Models HU-18-671-11 and  
HU-18-671-12 Hot Units

- |               |                       |
|---------------|-----------------------|
| 1. THERMOSTAT | 3. PILOT LIGHT, AMBER |
| 2. AIR VENTS  | 4. PILOT LIGHT, RED   |
|               | 5. TIMER              |

AN EXPERIENCED ELECTRICIAN CAN QUICKLY CHECK, FIND AND REPLACE THE DEFECTIVE PART. REFER TO WIRING DIAGRAMS FOR EITHER 110-120 V OR 220-240 V HOT UNITS.

Before leaving our plant, each Hot Cabinet is thoroughly inspected, tested and adjusted under various operating conditions. This model is UL listed and CSA certified for 2075 Watts, 110-120 and 220-240 Volts, single phase 60 Cyc. AC service. Refer to UL Guide No. 165E30.3, File No. E27846 and CSA File No. LR 18148.

No. LR 18148.

**Note:** A 20 Amp wall receptacle is required to operate unit. Also available are special Heating Units designed to operate on 220-240 Volt, 60 Cycle, 1 Phase, AC Service.

A cord clip on top rear of cabinet is provided for securing power supply cord when not in use.

### TO START UNIT

1. Start unit by turning timer knob (5) clockwise from OFF position to operating time desired. (Timer dial is graduated in 15 minute intervals up to 10 hours.)

Amber Pilot Light (3) will glow indicating power is ON.

Set thermostat (1) for cabinet temperature required. (Dial is graduated in approximately 25 increments, 1 thru 10 over the range of 25° to 250°F. No. 6 on dial is approximately 150°F.)

When unit starts up, built-in blower (under baffled intakes) draws air in, moving it over the heaters, and forcing it up through the tunnel in the rear of the cabinet. Louvers in the tunnel allow hot air circulation through the entire cabinet. Unit is thermostatically controlled, cycling the heater on and off automatically to maintain the desired temperature. The Red pilot light (4), when lit, indicates heater is on. The inside cabinet temperature can be read on the door mounted thermometer.

2. Additional humidity may be provided in the cabinet by adding water to the reservoir. Reservoir is provided with a lift-off perforated and baffled cover. Reservoir capacity is 1/2 gallon. Experience with cabinet will determine how much water is to be used.
3. We recommend that the Hot Cabinet be preheated for at least 30 minutes with thermostat set on 10 before use. This CRES-COR Hot Cabinet is primarily designed as a food warmer only, for maintaining food temperatures after food has been prepared. Hot or preheated foods can be kept at 150°F. or higher until ready for serving.

**Note:** To use the cabinet as a Cold Cabinet with CRES-COR's K-1218 Kold Keepers, dry ice or other coolants ---

Leave the thermostat (1) in the OFF position and turn timer knob (5) on. This will operate the blower and the cold air will circulate through the cabinet.

4. To shut off manually, turn timer knob (5) to OFF position. The Amber pilot light (3) will go out.

H-138-1034	FL-1470

**CLEANING**

1. Refer to FL-304 for removal of corrugated rack inserts. Cabinet is provided with lift-out type corrugated rack inserts and air circulation tunnel. These are readily removable without the use of tools.
2. Recommended cleaning procedure:
  - A. Remove and empty water reservoir at least once a week.
  - B. Clean the Cabinet inside as follows:

- (1) Remove Hot Unit.
- (2) Remove corrugated rack inserts and tunnel.
- (3) Use hot water and a detergent approved for aluminum in the concentration recommended.
- (4) Rinse in clean hot water, 170° to 190°F.
- (5) DO NOT USE ABRASIVES OR HARSH CHEMICALS.
- (6) Avoid getting water into hot unit controls.

**MAINTENANCE**

1. The heating unit may be removed from the cabinet. Remove the sheet metal screws (8) from each side panel on the outside of the cabinet. Slide entire heating unit from the front of cabinet.

2. Possible causes of failure to operate:

Failure	Cause - Check
A. Amber Pilot Light does not go on	A1. No power, defective cord or connections. A2. Timer not turned on. A3. Defective pilot light, timer switch or internal wiring.
B. Red Pilot Light does not go on	B1. Thermostat in OFF position. B2. Thermostat set too low. B3. Defective thermostat, heater, or pilot light.
C. Unit runs too hot.	C1. Thermostat set too high. C2. Defective thermostat.
D. Unit will not shut off.	D1. Defective timer - Pull Plug to shut off.
E. Blower does not operate.	E1. Defective blower.
F. Noisy Blower.	F1. Defective motor. F2. Loose Squirrel Cage. F3. Foreign object in blower.

Pilot Light, Red .....	CMP 766-47
Power Supply Cord Assy. ....	CMP 810-97
Thermometer Only .....	CMP 5238-8
Thermometer Kit .....	CMP 5240-6
Card Holder .....	CMP 5258-1
Door Latch Kit .....	CMP-1006-75

3. PARTS LIST - 220-240 V, 60 Cyc. AC Service - (1) Phase

Hot Unit Complete.....	CMP-HU-18-671-12
Heater Kit 2000W.....	CMP-6126-28
Timer Kit.....	CMP-6215-1
Motor Blower Kit.....	CMP-6227-1
Power Supply Cord.....	CMP-810-39
Pilot Light Amber.....	CMP-766-45
Pilot Light Red.....	CMP-766-46

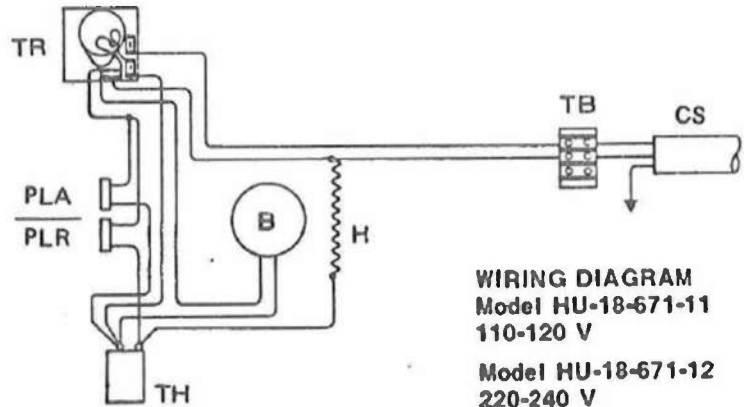

**WIRING DIAGRAM**  
Model HU-18-671-11  
110-120 V  
Model HU-18-671-12  
220-240 V

**REPLACEMENT PARTS**

1. When ordering replacement parts, please include all information shown on the heating unit (HU-18) name plate in addition to the CMP number of the part or parts required.

2. PARTS LIST 110-120 V, 60 Cyc. AC Service --- (1) Phase

Heating Unit .....	CMP HU-18-671-11
Water Reservoir .....	CMP 1017-10
Reservoir Cover Assy. ....	CMP 761-7
Heater Kit 2000 W .....	CMP-6126-27
Thermostat Kit .....	CMP 6216-1
Timer Replacement Kit .....	CMP 6215
Motor Blower Kit .....	CMP 6227
Pilot Light, Amber .....	CMP 766-48

**LEGEND**

H-	Heater	TB-	Terminal Block
TH-	Thermostat	PLR-	Pilot Light, Red
B-	Blower	PLA-	Pilot Light, Amber
TR-	Timer	CS-	Cord Set

I. REFRIGERATOR, UPRIGHT, REACH-IN

**HOBART**

# INSTRUCTION MANUAL

... with Replacement Parts

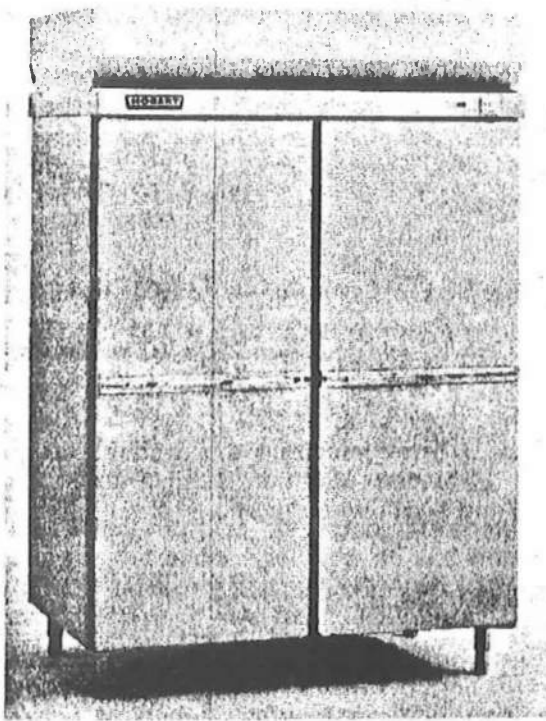

## MODEL H SERIES REFRIGERATORS

A product of HOBART CORPORATION

TROY, OHIO 45374

FORM 12262B (Rev. 2-77) (Supds. F. 12262A, 10-76)

## Installation, Operation and Care of MODEL H SERIES REFRIGERATORS

### IMPORTANT NOTICE TO INSTALLER:

It is the responsibility of the installer to properly install and adjust the unit in order to obtain good service after installation.

This refrigeration system has been properly charged and tested at the factory. It must be installed in accordance with established refrigeration practices, all specific instructions with the unit, and in compliance with any local codes. During shipment it may have been subjected to extreme stress and vibration. The installer must pay particular attention to the following important areas:

1. **INSTRUCTION MANUAL** – The installer must read and follow the instruction manual.
2. **SYSTEM TIGHTNESS** – Check all tubing and connections.
3. **HINGES, HANDLES, SCREW, ETC.** – Check for tightness.
4. **ELECTRICAL** – Proper voltage must be applied as shown on the data plate, located inside the cabinet in the upper left hand corner of the liner. Check all field connections and all accessible factory connections.
5. **ADEQUATE AIR** – Self-contained units must be located to insure an adequate air supply to the condenser. Check all fans to see that air is moving properly and without restriction.
6. **OPERATIONAL CHECK** – The refrigeration and defrost cycles should be checked for proper

operation before loading the cabinet with the product.

7. **CONTROL SETTINGS** – On freezers the defrost time control must be set to the proper time of day.

### SECTION A — GENERAL

The H Series reach-ins are available as Frozen Food Cabinets, Medium Temperature Refrigerators, and Warming Cabinets.

#### Frozen Food Cabinets:

Models HSF, HSDF, HVF, HVDF, HAF, and HADF Series Frozen Food Cabinets consist of one, two, or three section cabinets. A convertible "Dual Range" option is available which converts a frozen food cabinet into a normal temperature refrigerator by operating a selector switch.

#### Medium Temperature Refrigerators:

Models HS, HSD, HV, HVD, HA, and HAD Series Medium Temperature Refrigerators are available in one, two, or three section cabinets. A "Safe-T-Thaw" option is available which offers sanitary, convenient thawing of frozen foods while the refrigerator keeps food safe. This feature reduces food inventory storage needs, simplifies menu planning, and eliminates extra handling. It assures maximum quantity by maintaining thawed food at 38° to 40° F. until needed.

### Warming (Hot Food Storage) Cabinets:

Models HSH and HSDH Warming Cabinets are available in one, two, and three sections. Each vertical section of the cabinet is warmed by a 1000 watt heater and is controlled separately. A temperature control, humidity control, and indicator light are located directly above each section. Two temperature cabinets (combining hot food and refrigerator temperatures) and (refrigerator temperatures and frozen foods) are also available. Frozen food temperature cabinets are not available in combination with warming temperature cabinets.

**NOTE:** The warranty on your equipment must be registered within five days of installation date. Make sure that you receive a copy of the warranty certificate.

When replacement parts are necessary, make sure you give a complete and accurate description of the part or parts required. **ALWAYS GIVE SERIAL NUMBER AND MODEL NUMBER.**

## SECTION B — INSTALLATION

### B.1 Uncrate and Inspect.

B.1.1 When unit is delivered, it should be inspected for damage to crate and contents. If any damage has occurred, report it to the carrier at once and insist it be noted on the freight bill.

B.1.2 Remove crate carefully, leaving cabinet on skid until it is moved as close as possible to the final location.

B.1.3 Inspect the cabinet for damage. If damage of any kind is found, report it to the carrier at once and insist it be noted on the freight bill. The receiver must make a final inspection and report any damage to the carrier within 15 calendar days. **NOTE:** Concealed damage reported after the 15-day limit does not qualify as a freight claim.

B.2 Move cabinet and skid as close to the final location, then remove cabinet from skid.

B.2.1 Remove 5/16" bolts that secure cabinet to skid.

B.2.2 Remove cabinet from skid. A pry bar may be used but **MUST NOT BE USED TO SLIDE THE CABINET OR DAMAGE WILL OCCUR.**

B.3 Install the legs and level the cabinet (see Fig. 1).

B.3.1 Legs are packed in a separate carton along with an additional set of mounting instructions.

B.3.2 Raise and block up cabinet at least seven inches from the floor. **WARNING:** Cabinet should be blocked and stable before installing the legs.

B.3.3 Place the legs in position and install the leg mounting, self-tapping screws. Remove blocks.

B.3.4 Level the cabinet, front to back and side to side, by turning the micro-adjustable legs (see Fig. 1).

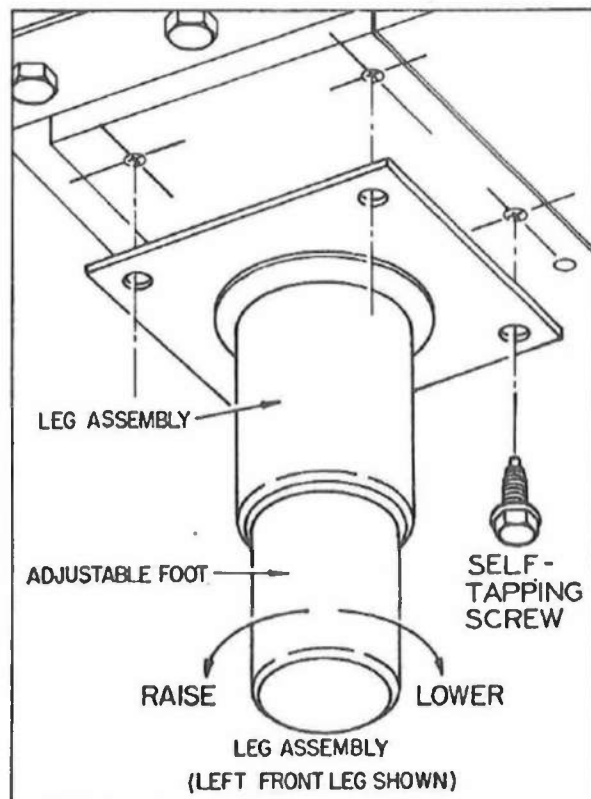

Fig. 1

## H SERIES INSTRUCTIONS

### B.4 Install shelves (see Fig. 2).

B.4.1 The shelves are packed in a carton separately from the cabinet, with an adequate supply of shelf clips.

B.4.2 Insert shelf clips in the pilaster.

B.4.3 Install shelves.

B.4.4 Bonus shelves are provided for added shelf area in front of the cold air ducts. They are positioned and held in place by the adjoining shelves.

**NOTE:** Index holes are provided in the pilaster to help in leveling the shelves.

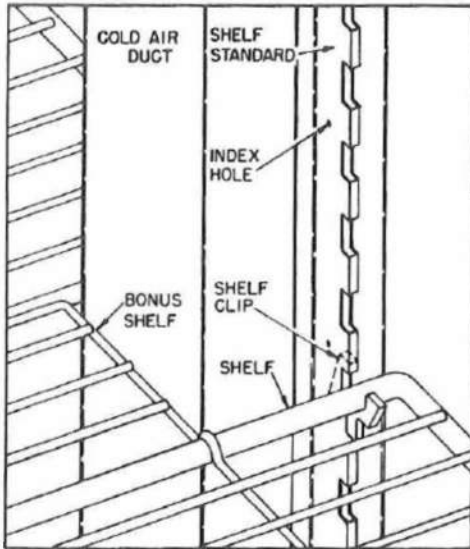

Fig. 2

B.5 Door(s) rehinging or removal (see sections E.19 and E.20).

B.6 Remove shipping block(s) when provided (see tag attached to compressor).

B.7 Locate refrigerant charge on top of condenser shroud (see parts listing).

B.8 Remove packaging and place heater in dish located on top of cabinets. Heater (furnished) is used for remote refrigeration systems. Connect heater to the electrical outlet provided.

B.9 Thermometer recalibration (see Fig. 3).

B.9.1 Compare the thermometer on the cabinet with an accurate test thermometer. If there is any variation, adjust as follows:

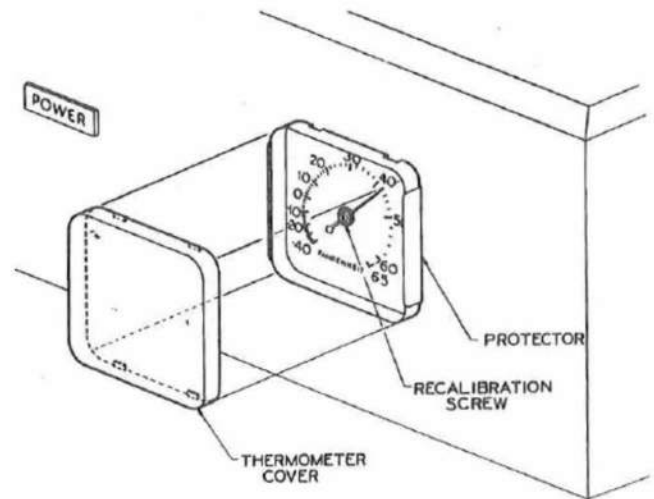

Fig. 3

B.9.1.1 Using a thin, bladed screwdriver, pry off the plastic cover.

B.9.1.2 While holding the zero adjusting screw with a screwdriver, turn the pointer to the correct reading with your fingers.

B.9.1.3 Snap plastic cover into place.

B.10 Defrost Timer (Freezers) (see Fig. 4).

B.10.1 The defrost cycle is time initiated and terminated by the defrost timer. Units are set for three 26-minute cycles per day (6 A.M.; 2 P.M.; and 10 P.M.) at the factory.

B.10.2 The front trim must be removed before setting defrost timer (see section E.1).

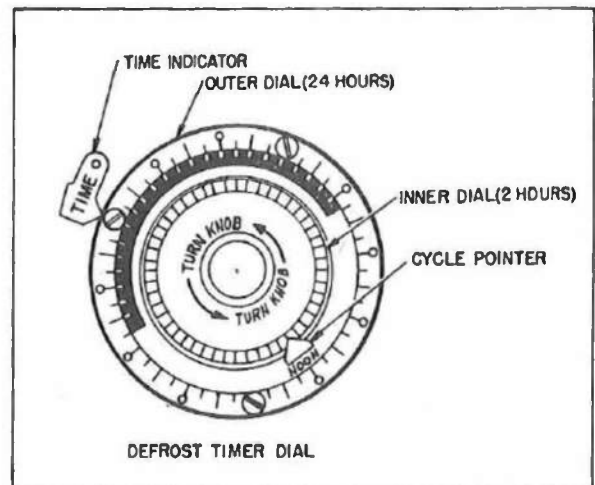

Fig. 4

B.10.3 To set the defrost timer to proper time of day, turn knob counterclockwise until proper time is opposite the time pointer.

B.10.4 If system is heavily used, it may be necessary to increase the number and length of the defrost cycles. To change defrost period, depress the cycle pointer and rotate it to the desired time period.

B.10.5 To change the time of defrost cycles, unscrew the pins located on outer dial and move to the desired time.

B.10.6 When the power supply is interrupted, the timer must be reset to the proper time of day.

## SECTION C — OPERATION & CLEANING

### C.1 Cleaning Cabinet.

C.1.1 The inside of the cabinet should be cleaned once a week. Use a mild soap or detergent, rinse thoroughly, and wipe dry with a clean soft cloth. If juices or food are spilled, they should be wiped up at once.

C.1.2 Clean the door gaskets weekly with a damp cloth.

C.1.3 Eliminate unpleasant odors by placing an open dish of unused coffee grounds or activated charcoal inside the cabinet.

### C.2 Periodic Inspection and Cleaning Condenser.

**NOTE:** The condenser should be inspected and cleaned as required on a regular schedule since dirt and lint will impair the efficiency of the unit.

C.2.1 Disconnect all electrical power supply to the cabinet.

C.2.2 Remove front trim (see section E.1).

C.2.3 Carefully vacuum or brush dirt or lint from the condenser.

C.2.4 Replace the front trim.

C.2.5 Periodically remove and clean the cooling coil drain pan (section E.13) and condensate dish (section E.3). Thoroughly wash dish in detergent.

C.2.6 Connect electrical power supply.

C.3 Controls (Warming Cabinet Only): A temperature control, humidity control, and indicator light (Fig. 5) are located directly above each section.

C.3.1 The humidity is controlled by a vent in the top of each section. The left-hand control knob rotates a cover over the vent tube. The size of the opening determines the amount of humidity. **NOTE:** The larger the opening the lower the humidity.

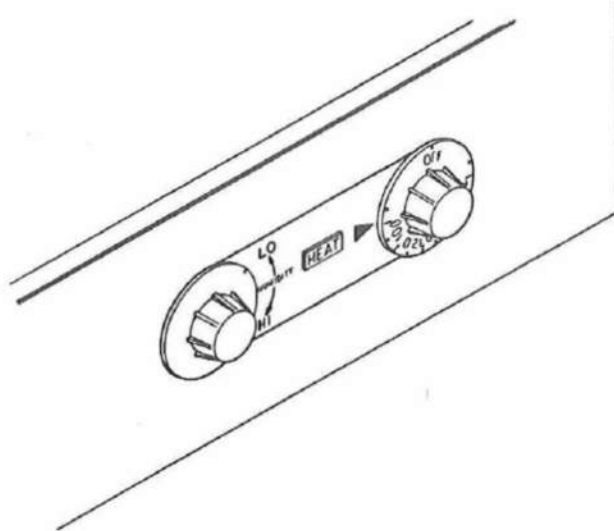

Fig. 5

C.3.2 The indicator light is on when the heater is on. The light will cycle off and on as the heater cycles.

C.3.3 The temperature control knob indicates a heat range. When the compartment reaches the temperature setting on the control, the heater will shut off. If the temperature drops below the control setting, the heaters will start up again.

### C.4 Controls (Refrigerators and Frozen Food cabinets).

C.4.1 Each temperature control has been factory set but local conditions may necessitate some adjustments. The temperature control is behind the compressor housing front. To service or adjust the temperature control, remove the housing front (see section E.1). To lower the temperature, turn the control knob (1, Fig. 9), (1, Fig. 10), (1, Fig. 11) or adjusting screw (1, Fig. 12). Turn the knob or adjusting screw in the direction of the arrow. Adjust a small amount each time. Replace compressor housing front.

## SECTION D — MAINTENANCE

### D.1 Lubrication.

D.1.1 Compressors on self-contained units and all fan motors are permanently sealed and require no further lubrication.

## SECTION E — SERVICE

### E.1 Removing and Replacing the Front Trim (see Fig. 6).

**NOTE:** It is necessary to remove the front trim to gain access to the refrigeration equipment on the top of the cabinet.

E.1.1 To remove, lift front trim up approximately one inch to disengage it from end panels, then pull forward.

E.1.2 To replace, engage clips in holes in end panels and push down.

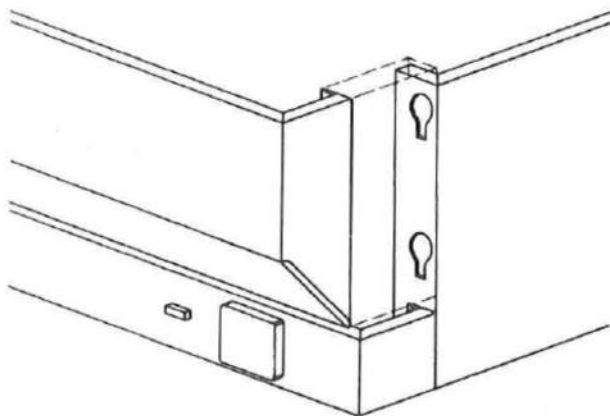

Fig. 6

### E.2 Removing and replacing Evaporator Housing (see Fig. 7).

**NOTE:** It is necessary to remove the evaporator housing to service the evaporator parts.

E.2.1 Disconnect all electrical power supply to the cabinet.

E.2.2 Remove front trim (see section E.1).

E.2.3 Remove shipping tie wire from latches and discard.

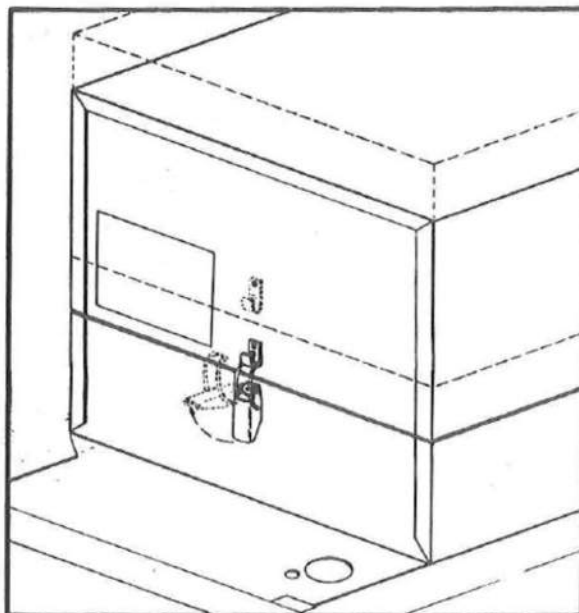

Fig. 7

E.2.4 Unhook the latches and lift off the housing taking care not to damage the refrigeration lines, electrical lines, or gasket.

**NOTE:** The housing for a single section cabinet should be moved about 5/8" to the left before raising in order to clear the end panel.

E.2.5 After cleaning and servicing, replace in the reverse order. **NOTE:** The evaporator housing must have a vapor tight seal.

### E.3 Condensate Evaporation Dish Removal (see Fig. 8).

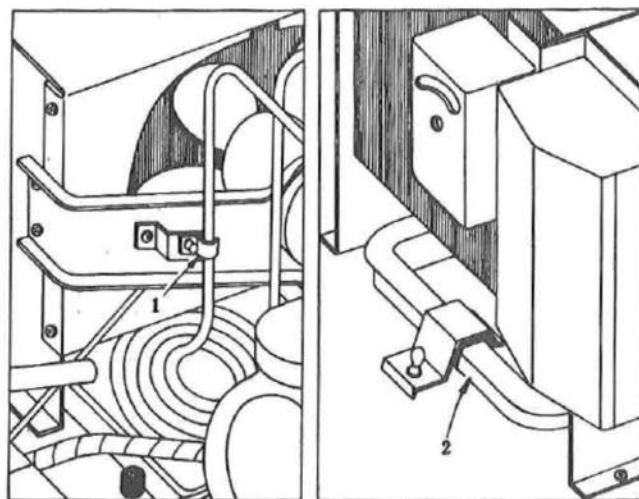

Fig. 8

E.3.1 Disconnect all electrical power to the cabinet.

E.3.2 Remove front trim (see section E.1).

E.3.3 Loosen discharge line from discharge line clamp (1, Fig. 8).

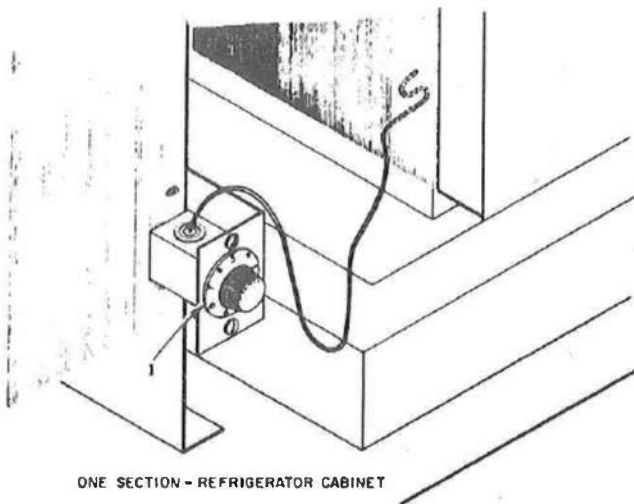

Fig. 9

E.3.4 Remove thumbscrew, dish clip, and cushion at front of evaporation dish (2, Fig. 8).

E.3.5 Remove evaporation dish by raising coiled discharge line out of dish and sliding dish toward front of cabinet.

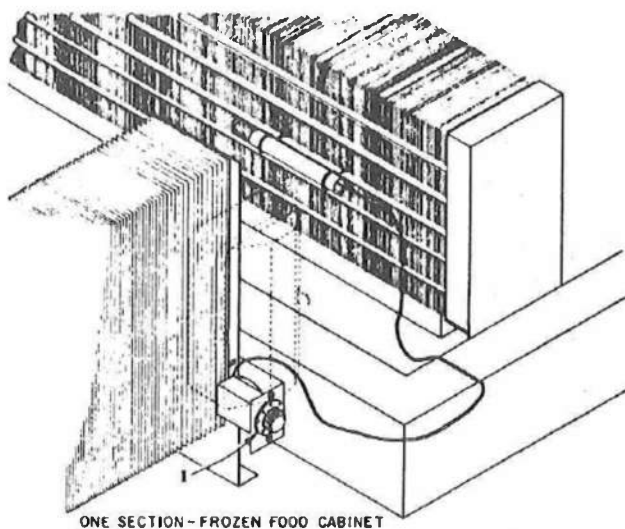

Fig. 10

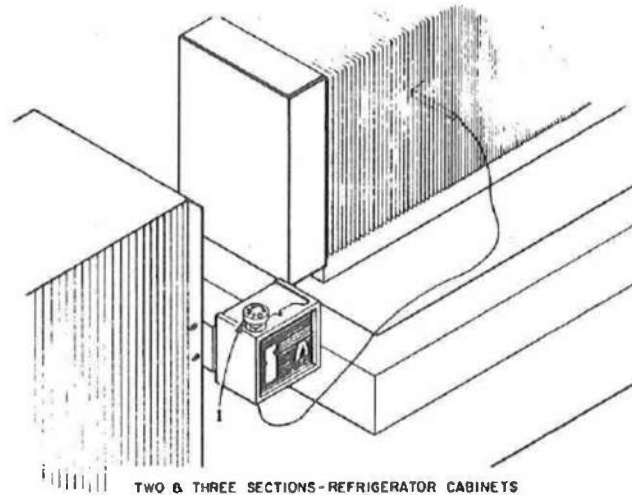

Fig. 11

E.3.6 Wash dish (see section C.2.5) and replace in reverse order. **NOTE:** When reinstalling the evaporation dish, the discharge line must be near the bottom and positioned to eliminate noise. Place the cushion between dish clip and dish.

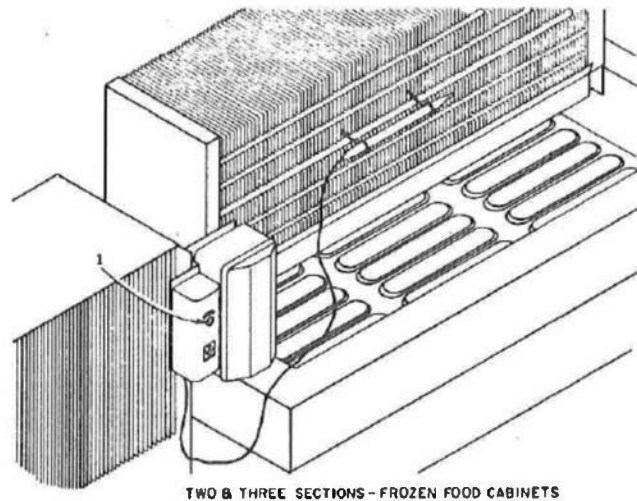

Fig. 12

E.4 Remove and Replace Temperature Control (see Figs. 9, 10, 11 & 12).

E.4.1 Disconnect all electrical power supply to the cabinet.

E.4.2 Remove front trim (see section E.1).

E.4.3 Remove evaporator housing (see section E.2).

## H SERIES INSTRUCTIONS

E.4.4 Remove electrical leads from temperature control and clip holding bulb.

E.4.5 Remove the old temperature control from bracket and install a new one (see Figs. 9, 10, 11 & 12).

E.4.6 Replace in reverse order observing bulb location. **CAUTION:** Make sure the capillary tube leading from the temperature control is not kinked or damaged.

### E.5 Remove and Replace Safety Thermostat (Freezers Only).

E.5.1 All frozen food cabinets are equipped with a safety thermostat to prevent overheating of contents, in case defrosting is completed before the timed termination.

E.5.1.1 Disconnect electrical power supply to cabinet.

E.5.1.2 Remove trim (see section E.1).

E.5.1.3 Remove evaporator housing (see section E.2).

E.5.1.4 Remove screws securing the evaporator to its supports and move the evaporator until the end with the safety thermostat is clear of the support.

E.5.1.5 Disconnect safety thermostat leads where leads are connected to the cabinet wiring.

E.5.1.6 Remove screws that retain thermostat to bracket.

E.5.1.7 Install new safety thermostat, reconnect wiring and reassemble cabinet in reverse order.

### E.6 Remove and Replace Defrost Heater (Freezers Only).

E.6.1 All frozen food cabinets are equipped with a coil defrost heater located on the front face of the coil.

E.6.1.1 Disconnect the electrical power supply to the cabinet.

E.6.1.2 Remove front trim (see section E.1).

E.6.1.3 Remove the evaporator housing (see section E.2).

E.6.1.4 Disconnect the coil defrost heater leads from the cabinet wiring (see Fig. 13).

E.6.1.5 Carefully remove heating element as not to damage fins of coil by pulling element away from coil face.

E.6.1.6 Insert the new heating element in the face coil slots, reconnect the heater leads, and reassemble cabinet.

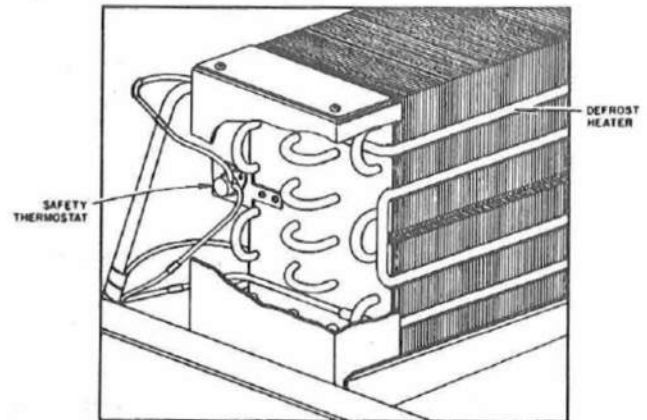

Fig. 13

### E.7 Power On Light Replacement.

E.7.1 Disconnect all electrical power supply to cabinet.

E.7.2 Remove front trim (see section E.1).

E.7.3 Remove screws and remove lower trim rail cover (see Fig. 14).

E.7.4 Depress the two spring clips that hold light and push it through front of lower trim rail.

E.7.5 Install new light.

E.7.6 Reassemble in reverse order.

### E.8 Automatic Light Switch Replacement (see Fig. 15).

E.8.1 Disconnect all electrical power supply to the cabinet.

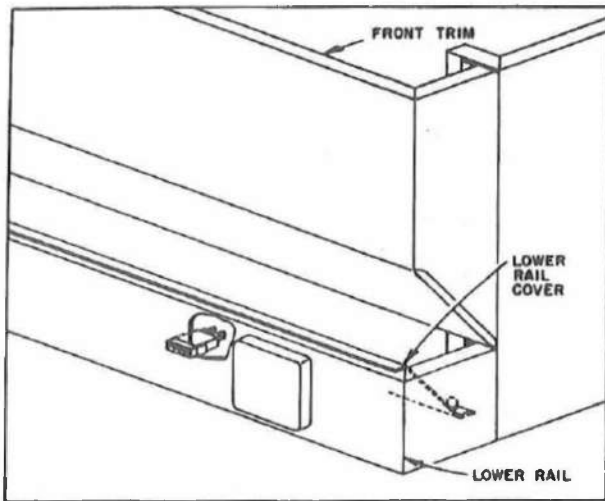

Fig. 14

E.8.2 Remove two switch mounting screws.

E.8.3 Pull switch through opening and disconnect from connector.

E.8.4 **NOTE:** Be sure to install new switch with slanted surface toward door (see Fig. 14). Reassemble in reverse order.

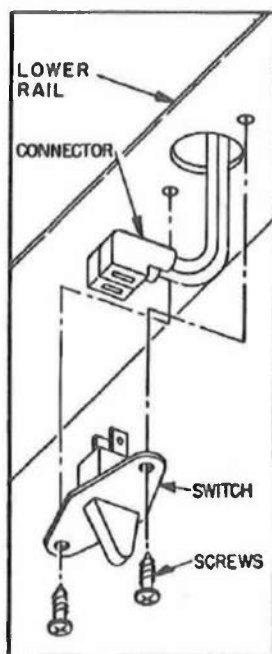

Fig. 15

E.9 Toggle Switch (Incandescent Lights) (see Fig. 16).

E.9.1 Cabinets with hinged glass doors are equipped with a manual (toggle) switch(s) and incandescent light(s). The switch is installed in the top of the liner and is next to the light shield. Replace toggle switch as follows:

E.9.1.1 Disconnect all electrical power supply to the cabinet.

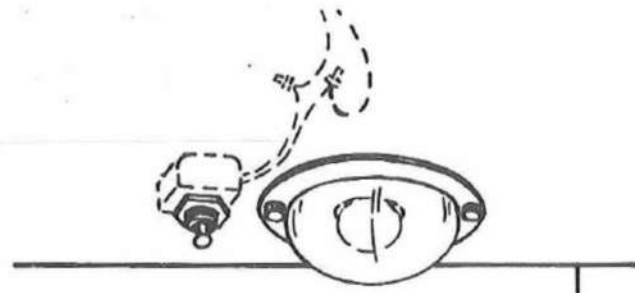

Fig. 16

E.9.1.2 Remove knurled nuts that fasten the light shield to the liner top. Remove shield and bulb.

E.9.1.3 Carefully remove the rubber light socket. Wiring can be damaged by pulling too hard on the socket.

E.9.1.4 Remove hex nut from the toggle switch and pull it through the light socket opening.

E.9.1.5 With the wiring for the toggle switch and light exposed, cut off the connectors.

E.9.1.6 Connect new switch lead wires to the cabinet wiring and replace the new switch in the liner top. Replace bulb, shield, and knurled nuts.

**NOTE:** The switch on a three section cabinet is located in front of the left-hand duct.

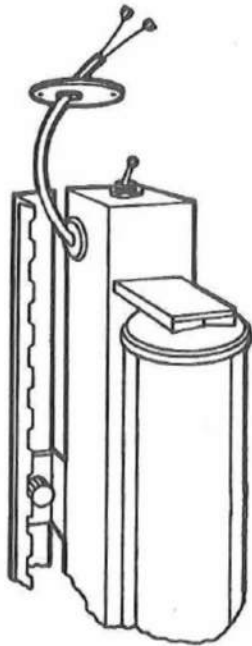

Fig. 17

**E.10 Toggle Switch (Fluorescent Light Assy.).**

E.10.1 Cabinets may be equipped with fluorescent lights with manual (toggle) switches. The manual switch is located on top of the light fixture (see Fig. 17). Replace toggle switch as follows:

E.10.1.1 Disconnect all electrical power supply to the cabinet.

E.10.1.2 Remove lamp and shield.

E.10.1.3 Remove cover plate and disconnect lead wires to lamp assembly.

E.10.1.4 Remove knurled nuts holding light box assembly.

E.10.1.5 Cut connectors that connect switch lead wires to cabinet wiring.

E.10.1.6 Unscrew hex nut and remove switch.

E.10.1.7 Install new switch in top of light box and connect the switch wiring to the cabinet wiring.

E.10.1.8 Remount light box to liner mullion and connect lamp assembly wiring to cabinet wiring.

E.10.1.9 Replace cover plate and connect to electrical power supply.

**E.11 Removing and Replacing Evaporator Fan (see Fig. 18).**

**NOTE:** The evaporator drain pan must be removed on a single section cabinet. With this exception, the service procedure for two and three sections are the same.

E.11.1 Disconnect electrical power supply.

E.11.2 Follow the procedure in section E.2 and remove evaporator housing. For single section cabinets, follow procedure in section E.13 (removing evaporator drain pan).

E.11.3 Disconnect the fan motor wire from the cabinet wiring and remove the male plug from the end of the fan motor wire. Remove the strain relief bushing on the orifice panel and allow the fan motor wire to fall through the hole.

E.11.4 Loosen and remove nut for the fan blade and remove fan blade.

E.11.5 Loosen and remove fan motor bracket retaining screws. Be sure to hold fan motor while removing screws to prevent motor falling and damaging liner top.

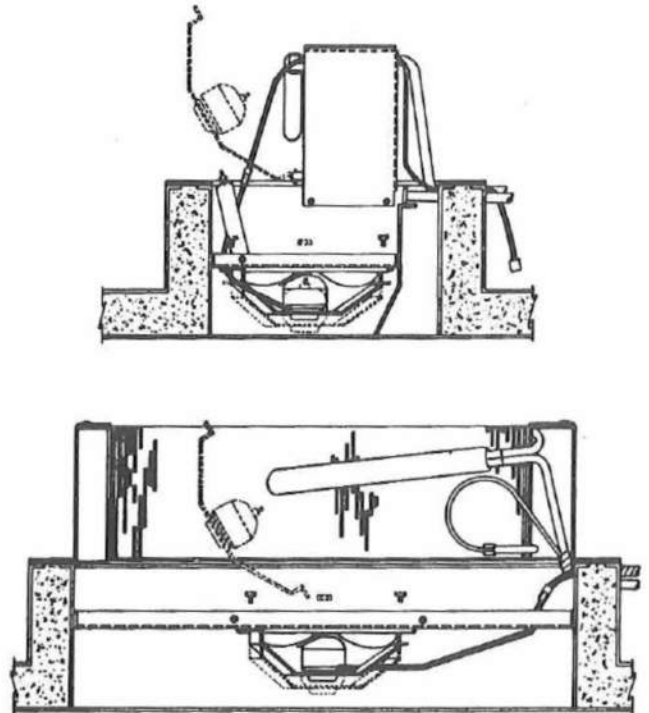

Fig. 18

E.11.6 Move bracket forward until end of bracket can be seen through orifice, then tilt up and remove.

E.11.7 With fan motor and bracket outside cabinet, remove screws that hold motor and bracket together. Replace with new motor and reassemble with bracket by reversing disassembly procedure.

E.12 Removing and Replacing Condenser Fan (see Fig. 19).

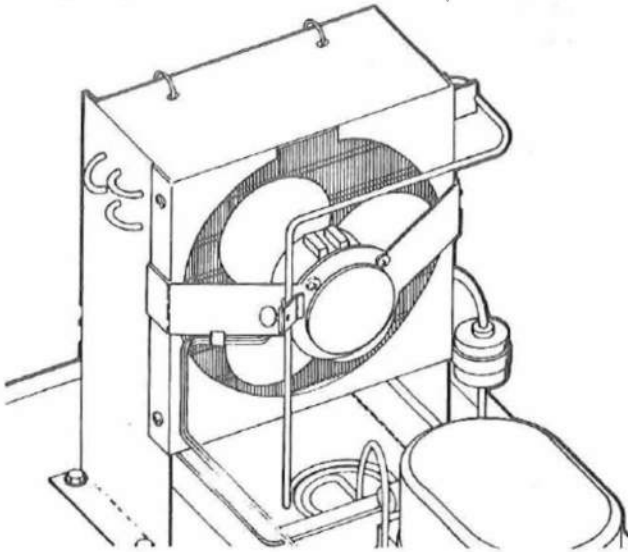

Fig. 19

E.12.1 Disconnect all electrical power supply to cabinet.

E.12.2 Remove front trim (see section E.1).

E.12.3 Remove two clips holding shroud to top of condenser and lift up shroud.

E.12.4 Remove fan blade from motor by removing hex nut and lock washer. When installing a new fan blade, be sure the convex side of the blade is toward the motor and a fiber washer is between the motor and fan blade.

E.12.5 Remove fan leads from junction box attached to compressor.

E.12.6 Remove three screws and washers that attach fan motor to bracket. Remove fan motor.

E.12.7 In reassembling, reverse procedure.

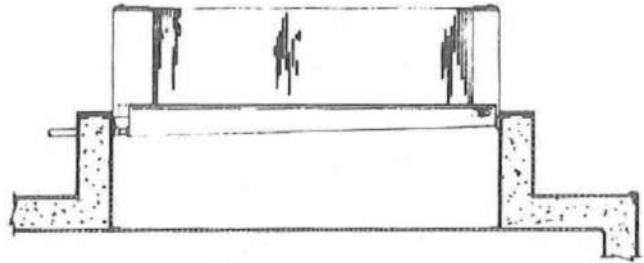

Fig. 20

E.13 Removing and Replacing Evaporator Drain Pan.

E.13.1 Disconnect electrical power supply to cabinet.

E.13.2 Remove front trim (see section E.1).

E.13.3 Remove evaporator housing (see section E.2).

E.13.4 See Figs. 20 and 21 and use the following procedure to remove drain pan on two and three section units:

E.13.4.1 Loosen thumbscrew and slide pan to the right.

E.13.4.2 Pull pan forward to clear thumbscrew and drop front edge down to release pan at rear of evaporator.

E.13.4.3 Remove drain pan at front.

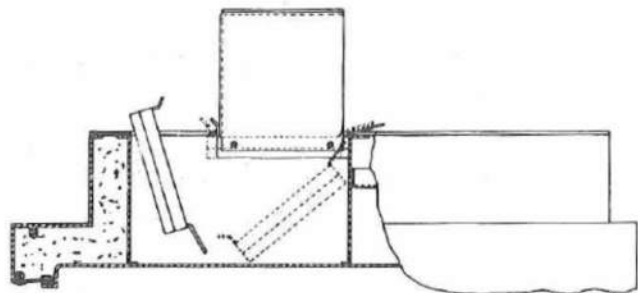

Fig. 21

## H SERIES INSTRUCTIONS

E.13.5 See Fig. 22 to remove drain pan on one section of cabinets and use the following procedure:

E.13.5.1 First, follow procedure as outlined in section E.13.4.1 and E.13.4.2.

E.13.5.2 Then loosen the two thumbscrews holding left side or rear of drain pan and move bracket away from pan and slide to the right.

E.13.5.3 Slide drain pan forward to remove front pin and remove by pulling pan forward to clear thumbscrew.

**NOTE:** It is important that accumulated deposits do not interfere with operation of the drain tube. Clean pan and drain tube thoroughly and replace in reverse order.

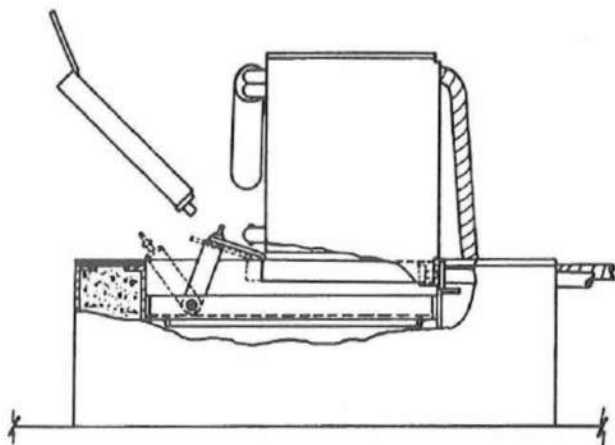

Fig. 22

### E.14 Removing and Replacing Drain Pan Heater (Freezer Only).

E.14.1 Follow procedure in section E.13 to remove drain pan.

E.14.2 Straighten heater clips that fasten heater to bottom of drain pan.

E.14.3 Replace heater and fold clips down. Reverse order of disassembly procedure.

### E.15 Removing and Replacing Anti-Condensate Heater.

The anti-condensate heater is located behind the front edge of vinyl door opening breakers.

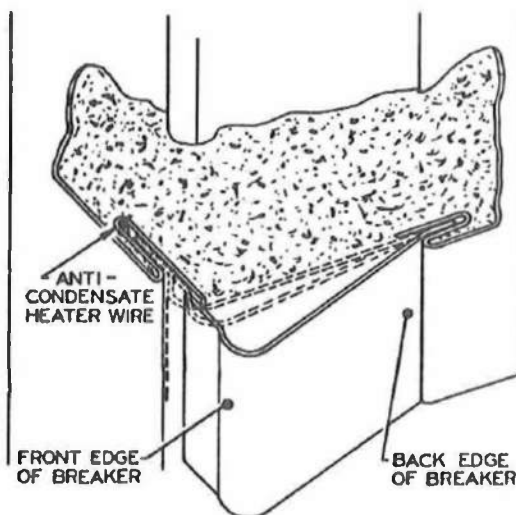

Fig. 23

E.15.1 Disconnect all electrical power supply to cabinet.

E.15.2 Remove breakers by exerting pressure at front edge (Fig. 23) toward center of door opening and pulling breaker toward front to release back edge of breaker. Disconnect anti-condensate wiring connection under rail cover.

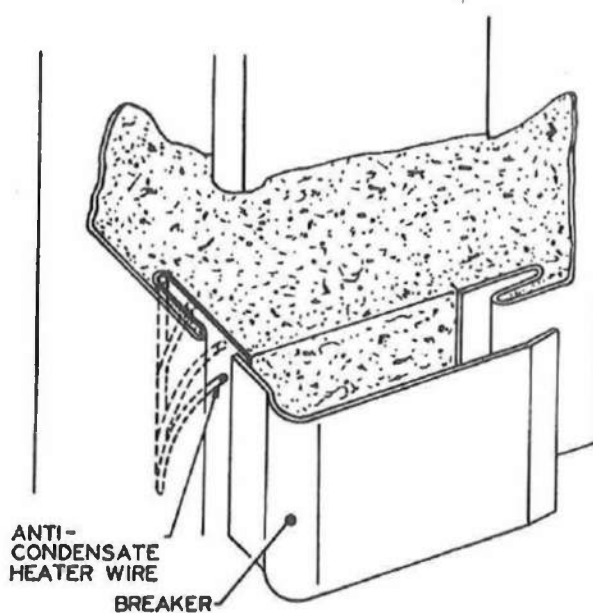

Fig. 24

E.15.2.1 Loosen screws securing rail cover and remove cover, to disconnect anti-condensate heater (wiring extending through cabinet).

E.15.3 Remove anti-condensate heater from hem of cabinet (Fig. 24).

E.15.4 Replace heater in hem. (Heater must be positioned at the bottom of the hem before installing breakers).

E.16 Replacing breaker.

E.16.1 Insert back edge of breaker in hem (Fig. 23). **NOTE:** Breaker must be completely retained in back hem before front hem engagement is possible.

E.16.2 Insert front edge of breaker in hem where anti-condensate heater is installed (Fig. 23).

E.16.3 Reconnect heater and replace rail cover.

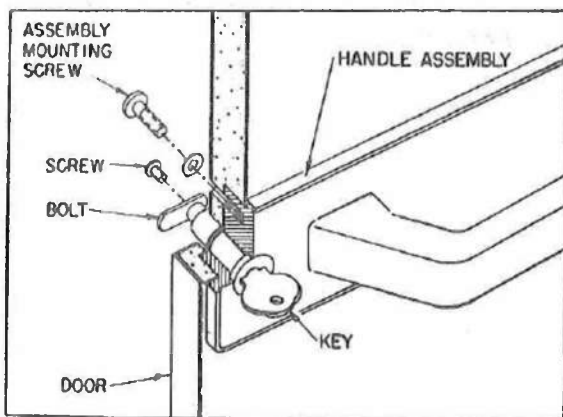

Fig. 25

E.17 Removing and Replacing the Door Handle Assy. (see Fig. 25).

**NOTE:** It may be necessary to remove the handle assembly in order to get cabinet through a door opening.

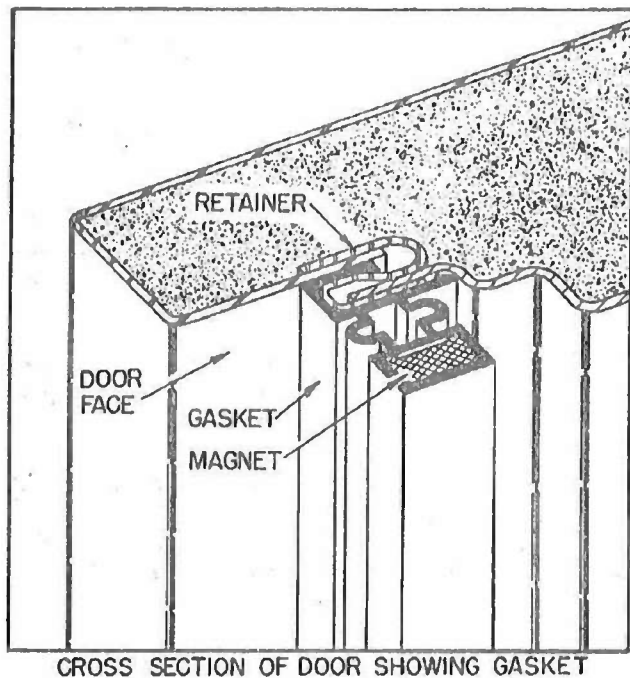

Fig. 26

E.17.1 Remove bolt from tumbler.

E.17.2 Remove the three mounting screws from the inside door and lift off handle assembly.

E.17.3 Replace in reverse order.

E.18 Removing and Replacing Door Gasket (see Fig. 26).

**NOTE:** It is not necessary to remove door from cabinet to replace the door gasket.

E.18.1 Pull old gasket off retainer.

E.18.2 Clean gasket retainer and remove any pieces of gasket material which may have broken off.

E.18.3 Start new gasket into retainer. After gasket is positioned, seat it firmly with a smooth object such as a spline roller. **CAUTION:** Do not tap gasket with a sharp or heavy object to avoid cutting or damaging gasket.

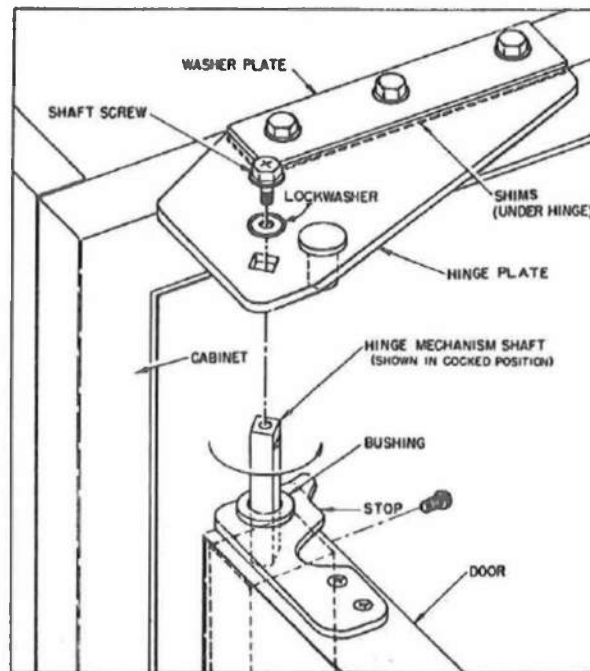

Fig. 27

E.19 Rehinging Door and Cocking Hinges (Full Height Units) (Fig. 27).

- E.19.1 Disconnect all electrical power to the cabinet.
- E.19.2 Remove front trim (see section E.1).
- E.19.3 Remove screws and rail cover (Fig. 14).
- E.19.4 Remove screws and washers from the hinge mechanism shaft at both top and bottom hinge.
- E.19.5 Open door to the 90° position to cock the hinge mechanism.
- E.19.6 Loosen upper hinge plate enough to lift it off hinge mechanism shaft.
- E.19.7 Lift door off lower hinge plate and remove.
- E.19.8 Remove hinge cutout cover in the top rail.
- E.19.9 Remove upper and lower hinge plates, washer plates and shims.
- E.19.10 Install upper hinge plate, washer plate and shim on lower opposite side and tighten.

E.19.11 Install lower hinge plate, washer plate and shim on upper opposite side, but do not tighten.

- E.19.12 Remove strike and shims.
- E.19.13 Remove the two white plug buttons and install strike in new location.
- E.19.14 Mount door on lower hinge plate by holding door perpendicular to cabinet and engaging hinge mechanism shaft in square hole on hinge plate.
- E.19.15 Position the hinge mechanism shaft on the top of the door in the square hole in the upper hinge plate.
- E.19.16 Tighten the upper hinge plate mounting screws.
- E.19.17 Replace the screws and washers for the upper and lower hinge mechanism and tighten.
- E.19.18 Install the remaining hinge cutout covers in the top rail over the exposed cutouts.
- E.19.19 Check the door for proper seal, operation of key locks and alignment of handles.

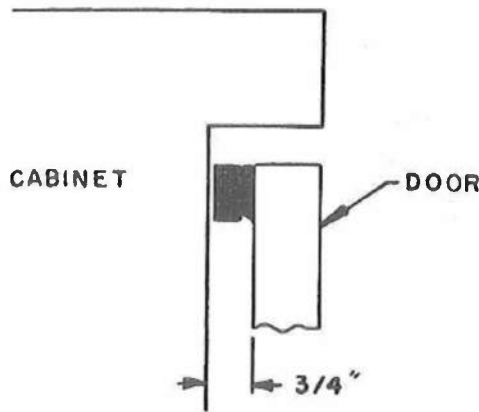

Fig. 28

**NOTE:** To adjust door, loosen the hinge plate mounting bolts. Adjust the door so it is approximately 3/4" from the face of the cabinet to the inside of the door face (see Fig. 28). Retighten the mounting bolts. Where hinges for two doors are mounted on the same mullion, hinges should be separated as far as possible (approximately 1-1/8" between doors). This will reduce interference when both doors are open at the same time. (Handles will contact when both doors are opened about 85°).

E.19.20 If the hinge mechanism should become uncocked while changing the door, it will be necessary to recock the hinge mechanism.

E.19.20.1 Remove the door from the cabinet.

E.19.20.2 Position the door face down on a work table.

E.19.20.3 Using a 5/16" open end or adjustable wrench, turn the hinge mechanism shaft 135° (see Fig. 29).

E.19.20.4 Mount the door on the cabinet (see E.19.14 thru E.19.19).

E.19.21 Reinstall the rail cover.

E.19.22 Replace the front housing trim.

E.19.23 Connect electrical power supply to the cabinet.

**E.20 Rehinging Door and Cocking Hinges (Full Height Units) (Alternate Method).**

Remove door as outlined in E.19.1, E.19.2, E.19.3, E.19.4 and E.19.6. With hinge plates loosely installed in appropriate location, proceed as follows:

E.20.1 Make sure the hinge cam is in the rest position (stem should have spring resistance when turned in either direction).

E.20.2 Set door in closed position against cabinet by inserting upper hinge stem upward through notch in trim rail. The upper hinge plate should be loose enough to allow bottom hinge pin to be swung into position above hole in lower hinge plate.

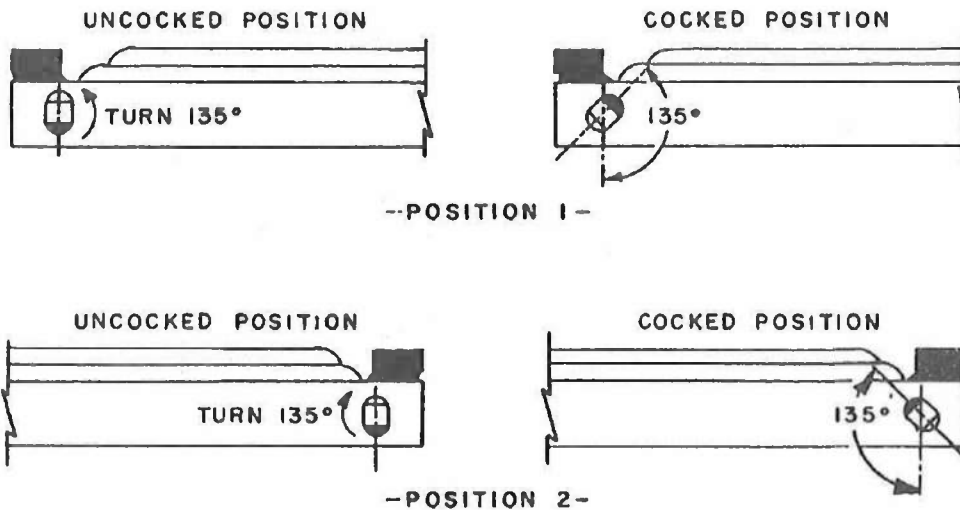

POSITION DOOR IN ONE OF THE TWO POSITIONS SHOWN.

Fig. 29

## H SERIES INSTRUCTIONS

---

- E.20.3 Using a thin 5/16" open end wrench, turn lower hinge stem in the DIRECTION OF DOOR CLOSING (45°) until the square stem indexes in hole in hinge plate. When the stem drops into the hinge hole, install stem screw immediately to prevent accidental disengagement.
- E.20.4 Index the upper hinge stem in the upper hinge plate as described in E.20.3 by turning stem in DIRECTION OF DOOR CLOSING (45°). Install and tighten stem screw immediately.
- E.20.5 Adjust alignment and door seals. Tighten all hinge screws.
- E.21 Rehinging doors (Half Height Units).
- On half height units, the center door hinge must be relocated.
- E.21.1 Install center hinge.
- E.21.2 Install upper and lower door after installing center hinge.
- E.22 Removing Hinge Mechanism (see Fig. 27).
- E.22.1 Remove door (see section E.19).
- E.22.2 Remove two screws from door edge and lift door stop plate off hinge mechanism plate.
- E.22.3 Remove two screws from interior side of door and lift mechanism from door.
- E.22.4 Replace in reverse order.
- E.23 Replacing Temperature Control (Warming Cabinet).
- E.23.1 Disconnect all electrical power supply.
- E.23.2 Remove front trim (see section E.1).
- E.23.3 Remove screws and remove the trim rail cover.
- E.23.4 Remove cover from junction box.
- E.23.5 Remove knurled nuts to remove vertical heater shield from inside the cabinet.
- E.23.6 Remove the rubber stopper in the liner top where the control bulb capillary tube enters the liner. Save the rubber stopper for reuse.
- E.23.7 Remove and save the clips which hold the control bulb to the heater.
- E.23.8 Pull the knob off of the control shaft. Remove the two control mounting screws, disconnect the wiring from the control and pull the control bulb through the hole in the top of cabinet.
- E.23.9 Feed the control bulb of the new control down through the hole in the cabinet top. CAUTION: Be very careful not to damage or kink the capillary tube.
- E.23.10 Fasten the control to the heater tubes with the mounting clip.
- E.23.11 Reinstall rubber stopper in liner hole. The stopper prevents heat and moisture loss.
- E.23.12 Replace heater shield.
- E.23.13 Coil the capillary tube carefully to take up excess length of tubing.
- E.23.14 Reconnect control wiring, remount control to lower rail and push knob control shaft.
- E.23.15 Replace the junction box cover, trim rail cover and front trim.
- E.23.16 Connect unit to electrical power supply.
- E.24 Replacing Heater (Warming Cabinet).
- E.24.1 Disconnect all electrical power supply.
- E.24.2 Remove front trim (see section E.1).
- E.24.3 Remove junction box cover and disconnect push-on heater wiring connectors.
- E.24.4 Remove the knurled nuts to remove heater shields from inside the cabinet.
- E.24.5 Remove the rubber stopper in the liner top where the control bulb capillary tube enters the liner. Save the rubber stopper for reuse.
- E.24.6 Remove and save the clips which retain the control bulbs to the heater.

E.24.7 Remove heater retainer bracket and slide heater down. Pull heater leads out through top of cabinet.

E.24.8 Slide leads of new heater (be sure electrical characteristics are the same) through cabinet top into junction box. Replace heater retainer brackets. Clamp control

bulb to the heater. Replace rubber stopper and heater shields.

E.24.9 Connect heater wiring to heater. Replace junction box cover and front trim.

E.24.10 Connect unit to the electrical power supply.

---

**SECTION XIII**

**NEW HARVEST EAGLE FIELD FEEDING SYSTEM  
ON-THE-JOB TRAINING GUIDE**

## PURPOSE

This guide provides information and guidance to be used by individuals in acquiring, while on the job, the knowledge and skills necessary to operate each major item of equipment in the New Harvest Eagle (NHE) Field Feeding System. It also offers an approach to certifying food service personnel as qualified field feeding experts.

## BACKGROUND

The NHE is an integrated field kitchen designed to be compatible with the support requirements of an operational environment that provides only a runway and sanitary drinking water, i.e., a "Bare Base." This system has a high potential for:

- Enabling food service personnel to produce high quality meals with more menu options than previous field kitchens;
- Improving efficiency and reducing effort through the use of improved menus, equipment, and procedures.

Like all technological developments, the NHE cannot achieve the full benefits promised by new equipment and processes unless each element is installed, operated, and maintained properly. For this to happen, each member of a food service unit must be familiar with the equipment and be able to operate it safely and efficiently.

## PROCEDURES

1. Examine the instruction manual and videotape to become familiar with the name and purpose of each item of equipment and assembly/operational instructions. Do this as soon as possible noting the learning objectives for each piece of equipment. These are the standards one must meet to become checked out, i.e., what you must be able to determine.
2. Select one or two items of equipment as the target(s) for check out and read the appropriate sections of the manual. Identify the actual piece of equipment and inspect it carefully by observation rather than use.
3. Seek out someone who has been checked out on the equipment and ask for a demonstration and opportunity to practice under his/her supervision.
4. When prepared to demonstrate that you know or can do the things listed as learning objectives in the manual, ask to be checked out by the training supervisor. If unsuccessful, continue practice and testing until the standards are met and your check out sheet has been signed.
5. When you have been successfully checked out on an equipment item, turn in the check out sheet to the supervisor, be prepared to help others, and turn to another item of equipment. Continue until you are checked out on all items. Note that the shelter complex is different from the other items. Unless you were involved in its erection, you may be unable to actually demonstrate your knowledge. If this be the case, check out may be limited to verbal descriptions of how operations are carried out. The video tape as well as the manual will provide useful information for a successful check out.

## COORDINATION AND CONTROL

Progress toward the objective of all members of the food service staff formally checked out on all items of equipment is monitored by the training supervisor. Administrative processing of records is minimized by returning all signed check out forms to the supervisor as soon as they have been completed. These forms are filed under the name of the appropriate staff member.

It should be noted that all listed learning objectives must be met for a check out signature to be justified. When a less-than-acceptable performance occurs on check out, additional practice along with an explanation of the error may be followed by additional demonstrations of the required skill and knowledge. Thus, the requirement in every case is mastery of all the skills and knowledge described in the learning objectives.

## CHECK OUT FORMS

For each item of equipment a separate form identifies the learning objectives or what must be demonstrated to be checked out on that item. At the bottom of the forms is a place for the printed name and signature of the individual certifying that all objectives have been met and the date.

One additional form is used. This is the individual record of equipment check out. It is retained as the individual's record of achievement and contains the date of check out and initials of the supervisor entered at the time of successful check out. This individual record form is provided below. NHE OJT check out forms are provided separately.

### INDIVIDUAL QUALIFICATION RECORD OF NHE EQUIPMENT

	CHECK OUT DATE	SUPERVISOR'S SIGNATURE
1. Shelter Complex Erection	_____	_____
2. Equipment Layout	_____	_____
3. Portable Water Heater and Pump	_____	_____
4. Grease Trap	_____	_____
5. Remote Tank Burner System	_____	_____
6. Shelter Lighting	_____	_____
7. Tent Heater	_____	_____
8. Steam Table and Griddle	_____	_____
9. Three Sink Assembly	_____	_____

	<b>CHECK OUT DATE</b>	<b>SUPERVISOR'S SIGNATURE</b>
10. Tray Pack	_____	_____
11. Deep-Fat Fryer/Ventilator/Filter	_____	_____
12. Electric Potato Extruder	_____	_____
13. Manual Potato Extruder	_____	_____
14. Tilt Fry Pan	_____	_____
15. Vegetable Slicer	_____	_____

**OJT TRAINING GUIDE AND CHECK OUT  
NHE PROTOTYPE FIELD FEEDING SYSTEM**

**EQUIPMENT: SHELTER COMPLEX – ERECTION**

Using the manual, available equipment, and with a previously qualified individual, learn and demonstrate that you can do **all** of the following. (If you did not assist in the erection of the shelter complex, describe correctly how each action listed below is carried out.)

1. Identify individual components of the shelter frame, with special attention being given to doorway purlins.
2. Work with another to assemble the shelter frame: arches, headers, and purlins.
3. Work with another to cover frame with a roof blanket which matches the type of ground purlin used.
4. Distinguish between ridge extenders and eave extenders, and install them in an appropriate place on the frame.
5. Work with another to attach fly.
6. Work with another (one person per arch) to erect shelter—first raise one side and then the other side of the shelter.
7. Secure the shelter with guylines and ground pegs.
8. Install the lighting bar between the headers. After installation of the lighting bar, the kitchen liner should be installed.
9. Work with another to install the liner inside the kitchen shelter.

**Vestibule**

10. Identify individual components of the vestibule frame.
11. Work with another to assemble, cover, and erect vestibule in position as a walkway between two adjoining shelters.

When all learning objectives have been demonstrated correctly, the supervisor and worker sign here.

\_\_\_\_\_  
Worker Name- Print

\_\_\_\_\_  
Signature

\_\_\_\_\_  
Supervisor Name-Print

\_\_\_\_\_  
Signature

Date \_\_\_\_\_

**EQUIPMENT: SHELTER COMPLEX – LAYOUT**

Using the manual, available equipment, and from a previously qualified individual, learn and demonstrate that you can do all of the following:

1. Identify the key pieces of interior and exterior food service equipment and describe their use.
2. Plan for appropriate location of key pieces of equipment and define the special requirements of these items.

When learning objectives have been demonstrated correctly, the supervisor and worker sign here.

\_\_\_\_\_  
Worker Name-Print

\_\_\_\_\_  
Signature

\_\_\_\_\_  
Supervisor Name-Print

\_\_\_\_\_  
Signature

Date \_\_\_\_\_

**EQUIPMENT: PORTABLE HOT WATER HEATER AND WATER PUMP**

Using the manual, available equipment, and from a previously qualified individual, learn and demonstrate that you can do **all** of the following:

1. Select a location for the pump and water heater in close proximity to the water source and kitchen.
2. Set up the water pump for operation including the attachment of the appropriate water hoses and electrical lead.
3. Orient and set up heater for operation including the attachment of appropriate water hoses, fuel lines, and electrical lead.
4. Set up fuel drum, install fuel-vent fill assembly in the drum, and attach the return and supply fuel lines from the heater to the corresponding fitting.
5. Perform the pre-start-up checks and start water pump.
6. Perform pre-start-up checks and start heater.
7. If the fuel-air mixture is not correct, a combustion specialist should be consulted.
8. Adjust flow of water to sink faucets.
9. Take corrective action in event of flame safeguard control "cut-off."
10. Shut down the heater and pump and prepare for storage.

When learning objectives have been demonstrated correctly, the supervisor and worker sign here.

\_\_\_\_\_  
Worker Name-Print

\_\_\_\_\_  
Signature

\_\_\_\_\_  
Supervisor Name-Print

\_\_\_\_\_  
Signature

Date \_\_\_\_\_

**EQUIPMENT: GREASE TRAP**

Using the manual, available equipment, and from a previously qualified individual, learn and demonstrate that you can do all of the following:

1. Choose a suitable site for location of grease trap. (A suitable site is defined in terms of distance from sinks, power source, elevation and discharge receptacle, as outlined in the manual.)
2. Dig a suitable hole for grease trap.
3. Identify components of the grease trap and assemble using hammer and nails.
4. Set up sump pump, float switch, and control box.
5. Connect water hoses and electrical lead to heater.
6. Test water flow into grease trap and check that trap operates automatically.
7. Take corrective action in the event of system failure.
8. Maintain grease trap routinely to avoid excessive grease build-up.
9. Describe removal of pump and heater and preparation of equipment for storage.

When learning objectives have been demonstrated correctly, the supervisor and worker sign here.

\_\_\_\_\_  
Worker Name-Print

\_\_\_\_\_  
Signature

\_\_\_\_\_  
Supervisor Name-Print

\_\_\_\_\_  
Signature

Date \_\_\_\_\_

**EQUIPMENT: KITCHEN SHELTER LIGHTING**

Using the manual, available equipment, and from a previously qualified individual, learn and demonstrate that you can do all of the following:

1. Unpack lighting tubes and position them for installation.
2. Install lighting tubes in suspension straps. Adjust suspension straps so that the lighting tubes hang level.
3. Connect lighting tubes in series and to a power source and switch each ON or OFF.
4. Disconnect lighting tubes.
5. Remove lighting tubes from suspension straps.
6. Place lighting tubes in case with transformer end (heavy ends) opposite each other.

When learning objectives have been demonstrated correctly, the supervisor and worker sign here.

\_\_\_\_\_  
Worker Name-Print

\_\_\_\_\_  
Signature

\_\_\_\_\_  
Supervisor Name-Print

\_\_\_\_\_  
Signature

Date \_\_\_\_\_

**EQUIPMENT: SHELTER HEATER**

Using the manual, available equipment, and from a previously qualified individual, learn and demonstrate that you can do all of the following:

1. Set up the tent heater, including the attachment of appropriate air ducts.
2. Start up the heater and describe the operating controls.
3. Adjust temperature and volume of air flow.
4. Shut down the tent heater and prepare it for storage.
5. Demonstrate correct fueling procedures.

When learning objectives have been demonstrated correctly, the supervisor and worker sign here.

\_\_\_\_\_  
Worker Name-Print

\_\_\_\_\_  
Signature

\_\_\_\_\_  
Supervisor Name-Print

\_\_\_\_\_  
Signature

Date \_\_\_\_\_

**EQUIPMENT: STEAMTABLE AND GRIDDLE**

Using the manual, available equipment, and from a previously qualified individual, learn and demonstrate that you can do all of the following:

1. Identify the individual component parts.
2. Assemble them correctly.
3. Demonstrate correct use, including filling and steamtables.
4. Demonstrate correct griddle cleaning procedures.

When learning objectives have been demonstrated correctly, the supervisor and worker sign here.

\_\_\_\_\_  
Worker Name-Print

\_\_\_\_\_  
Signature

\_\_\_\_\_  
Supervisor Name-Print

\_\_\_\_\_  
Signature

Date \_\_\_\_\_

**EQUIPMENT: TRIPLE SINK ASSEMBLY**

Using the manual, available equipment, and from a previously qualified individual, learn and demonstrate that you can do all of the following:

1. Identify the individual component parts.
2. Assemble them correctly.
3. Describe procedures for the efficient use of the sinks, the drain boards, and storage racks.
4. Identify the correct water temperatures for each sink compartment.

When learning objectives have been demonstrated correctly, the supervisor and worker sign here.

\_\_\_\_\_  
Worker Name-Print

\_\_\_\_\_  
Signature

\_\_\_\_\_  
Supervisor Name-Print

\_\_\_\_\_  
Signature

Date \_\_\_\_\_

**EQUIPMENT: TRAY PACK**

Using the manual, available equipment, and from a previously qualified individual, learn and demonstrate that you can do all of the following:

1. Describe the different types of equipment and procedures for heating tray-packed foods to serving temperatures.
2. Utilize correct procedures for heating, opening and serving tray-packed products.
3. Describe correct techniques for handling a high volume of tray packs in the kitchen and in storage.

When learning objectives have been demonstrated correctly, the supervisor and worker sign here.

\_\_\_\_\_  
Worker Name-Print

\_\_\_\_\_  
Signature

\_\_\_\_\_  
Supervisor Name-Print

\_\_\_\_\_  
Signature

Date \_\_\_\_\_

## EQUIPMENT: DEEP-FAT FRYER; FAT FILTER; PROXIMITY VENTILATOR

Using the manufacturer's operational manual\* for the deep-fat fryer, fat filter, and ventilator, as applicable, learn and demonstrate that you can do all of the following:

1. Deep-Fat Fryer
  - a. Connect unit to electrical supply source.
  - b. Identify operating controls.
  - c. Place frying medium in cooking vessel.
  - d. Turn fryer **ON**, set thermostat to desired temperature.
  - e. Operate fryer.
  - f. Turn fryer **OFF**.
  - g. Drain fat (cautiously).
  - h. Clean deep-fat fryer unit.
2. Fat Filter
  - a. Connect unit to electrical supply source.
  - b. Identify operating controls.
  - c. Drain hot fat from deep-fat fryer into fat filter reservoir.
  - d. Filter oil per manufacturer's operational manual.
  - e. Clean fat filter unit.
3. Ventilator
  - a. Open ventilator door adjacent to fryer.
  - b. Identify ventilator components.
  - c. Operate ventilator.
  - d. Observe filters for fat buildup.
  - e. Clean ventilator unit.

\*See Section VIII of the  
"Instructional Manual"

When learning objectives have been demonstrated correctly, the supervisor and worker sign here.

\_\_\_\_\_  
Worker Name-Print

\_\_\_\_\_  
Signature

\_\_\_\_\_  
Supervisor Name-Print

\_\_\_\_\_  
Signature

Date \_\_\_\_\_

**EQUIPMENT: POTATO EXTRUDER; AUTOMATIC, ELECTRIC OPERATED & POTATO EXTRUDER; MANUALLY OPERATED**

Using the manufacturer's operational manual\* for the electrically operated automatic potato extruder, learn and demonstrate that you can do all of the following:

**1. Potato Extruder, Automatic, Electric**

- a. Assemble unit as per manufacturer's operational manual including the hopper extension.
- b. Connect unit to supply sources, i.e., water and electrical.
- c. Identify control switches and indicator lights.
- d. Load hopper with potato product.
- e. Place cylinder in charge position (vertical).
- f. Actuate switch to charge cylinder.
- g. Place charged cylinder on normal operating position.
- h. Assemble cutter unit, cutter blade, baffle and front panel assembly.
- i. Operate unit.
- j. Shut off unit.
- k. Disassemble unit.
- l. Clean unit.

**2. Potato Extruder, Manually Operated**

- a. Identify components per manufacturer's manual.
- b. Load cylinder with product.
- c. Place loaded cylinder on unit.
- d. Extrude potato.
- e. Disassemble unit and clean.

\*See Section VIII of the  
"Instructional Manual"

When learning objectives have been demonstrated correctly, the supervisor and worker sign here.

\_\_\_\_\_  
Worker Name-Print

\_\_\_\_\_  
Signature

\_\_\_\_\_  
Supervisor Name-Print

\_\_\_\_\_  
Signature

Date \_\_\_\_\_

**EQUIPMENT: TILTING FRY BRAISING PAN**

Using the manufacturer's operational manual\* for the tilt fry pan, as applicable, learn and demonstrate that you can do all of the following:

1. Connect unit to electrical supply source.
2. Identify controls and tilting mechanism.
3. Operate tilt fry pan per manufacturer's operational manual.
4. Clean tilt fry pan.

When learning objectives have been demonstrated correctly, the supervisor and worker sign here.

\*See Section VIII of the "Instructional Manual"

\_\_\_\_\_  
Worker Name-Print

\_\_\_\_\_  
Signature

\_\_\_\_\_  
Supervisor/ Name-Print

\_\_\_\_\_  
Signature

Date \_\_\_\_\_

**EQUIPMENT: VEGETABLE SLICER**

Using the manufacturer's operational manual\* for the vegetable slicer, as applicable, learn and demonstrate that you can do all of the following:

1. Connect unit to electrical supply source.
2. Operate slicer per manufacturer's operational manual.
3. Disassemble unit and clean.
4. Assemble unit after cleaning.

When learning objectives have been demonstrated correctly, the supervisor and worker sign here.

\*See Section XII of the "Instructional Manual"

\_\_\_\_\_  
Worker/Name-Print

\_\_\_\_\_  
Signature

\_\_\_\_\_  
Supervisor Name-Print

\_\_\_\_\_  
Signature

Date \_\_\_\_\_

**EQUIPMENT: REMOTE TANK BURNER SYSTEM**

Using the manual, the components of the burner system, and from a previously qualified individual, learn and demonstrate that you can do all of the following:

1. Identify and describe the function of each component of the system.
2. Describe the layout of component parts and the fuel/air line configuration for the basic New Harvest Eagle.
3. Describe burner system start-up procedures.
4. Start up burner system from complete shutdown mode.
5. Remove an individual burner unit from the system, perform preventive maintenance on burner, and return unit to system.
6. Demonstrate correct response (mock) to system failures, e.g., pressure loss, unit flame out, safety valve malfunction, gasoline fire inside shelter.
7. Shut down burner system from full operational mode.

When learning objectives have been demonstrated correctly, the supervisor and worker sign here.

\_\_\_\_\_  
Worker Name-Print

\_\_\_\_\_  
Signature

\_\_\_\_\_  
Supervisor Name-Print

\_\_\_\_\_  
Signature

Date \_\_\_\_\_

**SECTION XIX**  
**GUIDELINES FOR FOOD SERVICE MANAGERS**

The New Harvest Eagle is designed to provide high quality food service in the field with minimum manpower. In its field tests, the New Eagle functioned in accordance with its design criteria and was well received by customers and food service personnel.

To operate at maximum efficiency, the Eagle must be managed at maximum effectiveness. The management of a field feeding system presents a unique challenge to the food service manager, for it is in the field where worker interaction becomes most intense, and where time constraints produce highest pressure.

To assist the manager in managing the New Harvest Eagle, videotapes and an instructional manual have been produced. These contain procedures for system set-up and operation, and an OJT program guide. Additionally, to provide general direction to the manager, several general principles of effective management are listed below. These are not intended to describe the many faceted task of system management, but to offer guidelines for the manager's most useful analyses—self-analysis.

- The successful manager is a builder of teams capable of innovation and adaptation to diverse situations.
- The successful manager recognizes and reinforces productive behavior. He does not reinforce counter productive behavior.
- The effective manager can operate and teach others to operate food service equipment.
- The mission-oriented manager assigns high priority to training all his people to operate each piece of equipment and perform each major task required of a field situation.
- The development-conscious manager is open to varied approaches to planning, implementing, and assessing food service operations.
- The productive manager includes his workers in system appraisal and development.

This document reports research undertaken at the US Army Natick Research and Development Command and has been assigned No. NATICK/TR-821034 in the series of reports approved for publication.