

AD-A120 834

AZIMUTH MONITORING EXPERIMENT STATUS REPORT(U) AIR
FORCE GEOPHYSICS LAB HANSCOM AFB MA R L ILIFF ET AL.
26 JUL 82 AFGL-TR-82-0200

1/1

UNCLASSIFIED

F/G 1777

NL



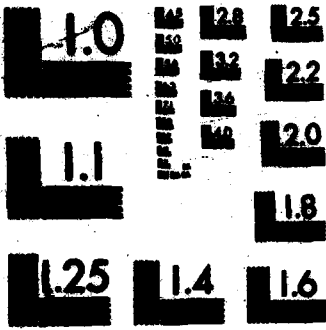

MICROCOPY RESOLUTION TEST CHART
NATIONAL BUREAU OF STANDARDS-1963-A

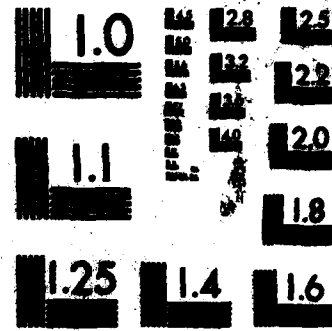

MICROCOPY RESOLUTION TEST CHART
NATIONAL BUREAU OF STANDARDS-1963-A

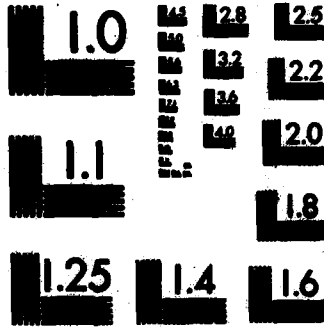

MICROCOPY RESOLUTION TEST CHART
NATIONAL BUREAU OF STANDARDS-1963-A

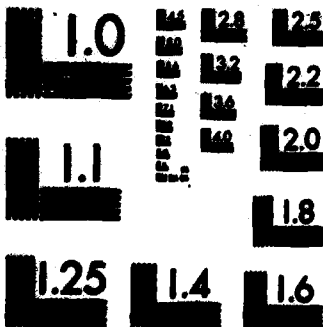

MICROCOPY RESOLUTION TEST CHART
NATIONAL BUREAU OF STANDARDS-1963-A

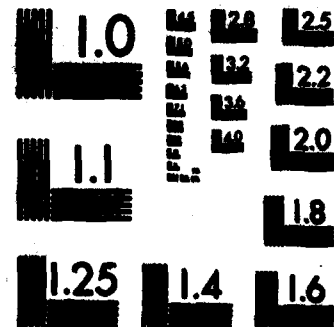

MICROCOPY RESOLUTION TEST CHART
NATIONAL BUREAU OF STANDARDS-1963-A

12

ADA 120834

AFGL-TR-82-0200
INSTRUMENTATION PAPERS, NO. 311



Azimuth Monitoring Experiment Status Report

ROBERT L. ILIFF
ROGER W. SANDS, TSgt , USAF
THEODORE E. WIRTANEN

26 July 1982

DTIC
OCT 29 1982
S H

Approved for public release; distribution unlimited.

FILE COPY

TERRESTRIAL SCIENCES DIVISION PROJECT 7600
AIR FORCE GEOPHYSICS LABORATORY
HANSCOM AFB, MASSACHUSETTS 01731

AIR FORCE SYSTEMS COMMAND, USAF



82 10 29 021

[REDACTED]

Unclassified

SECURITY CLASSIFICATION OF THIS PAGE (When Data Entered)

REPORT DOCUMENTATION PAGE		READ INSTRUCTIONS BEFORE COMPLETING FORM
1. REPORT NUMBER AFGL-TR-82-0200	2. GOVT ACCESSION NO. AD-A120 834	3. RECIPIENT'S CATALOG NUMBER
4. TITLE (and Subtitle) AZIMUTH MONITORING EXPERIMENT STATUS REPORT	5. TYPE OF REPORT & PERIOD COVERED Scientific. Final.	
	6. PERFORMING ORG. REPORT NUMBER IP No. 311	
7. AUTHOR(s) Robert L. Iliff Roger W. Sands. TSgt, USAF Theodore E. Wirtanen	8. CONTRACT OR GRANT NUMBER(s)	
9. PERFORMING ORGANIZATION NAME AND ADDRESS Air Force Geophysics Laboratory (LWG) Hanscom AFB Massachusetts 01731	10. PROGRAM ELEMENT, PROJECT, TASK AREA & WORK UNIT NUMBERS 62101F 76000605 76000607	
11. CONTROLLING OFFICE NAME AND ADDRESS Air Force Geophysics Laboratory (LWG) Hanscom AFB Massachusetts 01731	12. REPORT DATE 26 July 1982	
	13. NUMBER OF PAGES 21	
14. MONITORING AGENCY NAME & ADDRESS (if different from Controlling Office)	15. SECURITY CLASS. (of this report) Unclassified	
	15a. DECLASSIFICATION/DOWNGRADING SCHEDULE	
16. DISTRIBUTION STATEMENT (of this Report) Approved for public release; distribution unlimited.		
17. DISTRIBUTION STATEMENT (of the abstract entered in Block 20, if different from Report)		
18. SUPPLEMENTARY NOTES		
19. KEY WORDS (Continue on reverse side if necessary and identify by block number) Geodesy Azimuth Lasers Prismatic reflectors		
20. ABSTRACT (Continue on reverse side if necessary and identify by block number) With the increase in precision of inertial guidance systems has come a parallel need for techniques to monitor and measure the stability of azimuth references. These azimuth references are used to transfer astronomic direction to inertial system test platforms, for rocket engine test tracks, and for precision test facilities construction, among other requirements. Vibration damping techniques, the peculiarities of differential expansion, refraction, diffraction all emphasize that we are building on a living, moving earth, within the bottom layers of an ocean of air. Thus anything which can monitor and		

DD FORM 1 JAN 73 1473

Unclassified
SECURITY CLASSIFICATION OF THIS PAGE (When Data Entered)

Unclassified

SECURITY CLASSIFICATION OF THIS PAGE(When Data Entered)

20. (contd)

measure the stability of USAF's carefully surveyed azimuths will help in the progress toward precision. AFGL initiated the concept of monitoring the rotational and translational movements of directional references.



Accession For	
DTIC GRA&I	<input checked="" type="checkbox"/>
DTIC TAB	<input type="checkbox"/>
Unannounced	<input type="checkbox"/>
Justification	
By _____	
Distribution/	
Availability Codes	
Dist	Avail and/or Special
A	



Unclassified

SECURITY CLASSIFICATION OF THIS PAGE(When Data Entered)

Contents

1. INTRODUCTION	5
2. THE REQUIREMENT	5
3. OBJECTIVE	7
4. DESCRIPTION OF EXPERIMENT	8
5. DATA RECORDING AND REDUCTION	9
6. RESULTS	17
7. SYSTEM RESPONSE LINEARITY	18
8. CONCLUSION	19

Illustrations

1. Source-Reflector Motion Combinations	6
2. Azimuth Monitoring System	7
3. Transmitting and Receiving Equipment	8
4. Optical Targets	9
5. External Target Mount	10
6. Photodiode	11
7. Dual Axis Photodiode Position Sensor	12

Illustrations

8.	Y Rotation Data Plot	13
9.	X Rotation Data Plot	14
10.	Y Translation Data Plot	15
11.	X Translation Data Plot	16
12.	Y Rotational Data Plot	17
13.	Photodiode Calibration Plot	18
14.	Photodiode Calibration Data	19
15.	Spectral Analysis, Y Rotation	20
16.	Spectral Analysis, X Rotation	20
17.	Spectral Analysis, Y Translation	21
18.	Spectral Analysis, X Rotation	21

Azimuth Monitoring Experiment Status Report

1. INTRODUCTION

AFGL personnel have recently completed a series of field tests designed to establish the sensitivity and stability of an azimuth monitoring device in an operational environment. The experimental system was set up at the Satellite Tracking Station, New Boston AFS, New Hampshire, and operated over an 8-day period. Later, a 6-day record was collected at AFGL, Bedford, Massachusetts. Data taken emphasized the stability of the recording equipment. Additional tests were directed toward the sensitivity of the measuring sensors to any movement of the reflected light sources.

2. THE REQUIREMENT

The Air Force, during facilities construction, testing of navigation and guidance sensors, and in its ballistic weapons delivery mission, has many requirements for verification of the directional integrity of azimuth reference markers. The azimuth references are used for precision directional references in the operation and testing of guidance sensors, and in the siting of various structures for operational use. A carefully established azimuth reference requires considerable labor and the use of

(Received for publication 22 July 1982)

expensive equipment. The most critical of these directional references are re-observed frequently to determine if they have maintained directional validity. Because the earth is subject to many sources of movement, a requirement has evolved for a method of monitoring the horizontal rotation and translation of these directional references. It is necessary to determine the magnitude, direction, and frequency of these positional movements and the extent they affect weapons component test precision, missile guidance precision, and structural alignment precision. There are other considerations—station location, local topography, and so on, which may require that the measuring unit and targets be separated by a distance of 100 m or more. Also, a single configuration of one emitter/receiver and one set of target reflectors will not tell whether the motion is at the emitter or the targets (Figure 1). However, another target placed at a different azimuth will reduce the problem. The motions can be monitored by alternately sending the output beams to each set of targets and noting the relative movement. A mirror in the beam path can be used for this redirection.

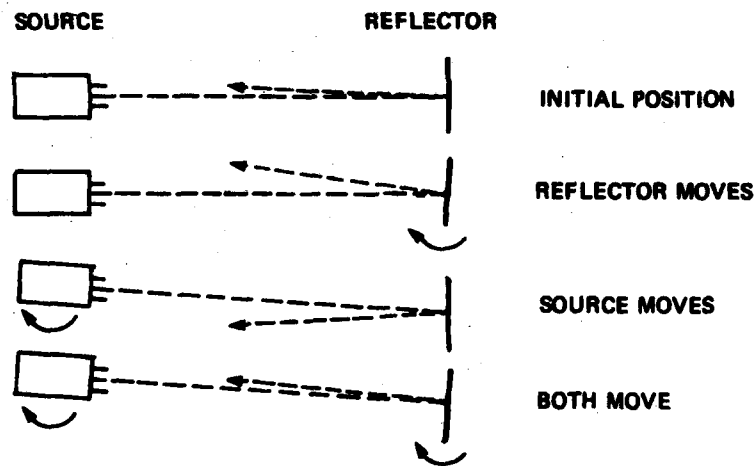

Figure 1. Source-Reflector Motion Combinations

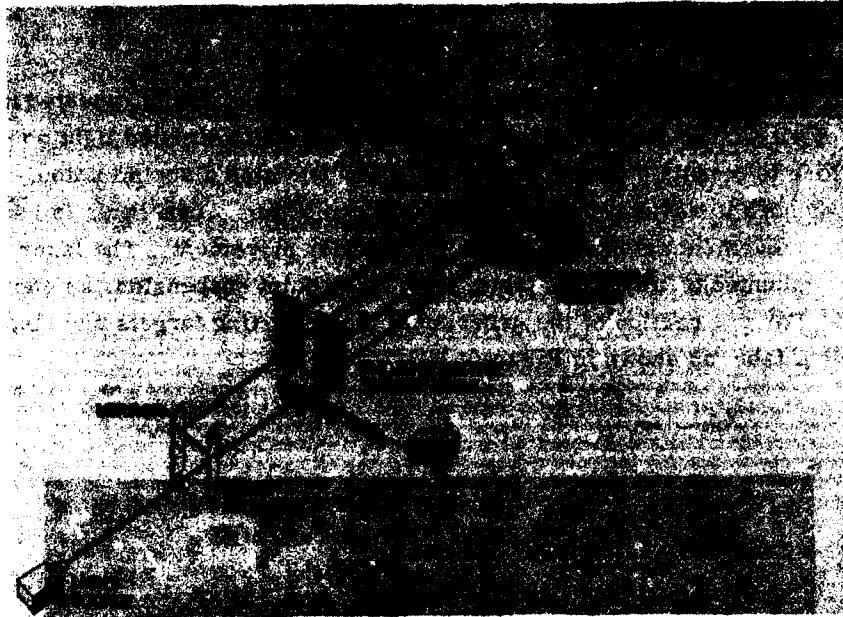

Figure 2. Azimuth Monitoring System

3. OBJECTIVE

The Air Force Geophysics Laboratory has developed a device which can precisely monitor the translational and rotational movements of reference pillars, test tables, and other devices where the stability of alignment must be known. The goal with this experiment is to be able to track and record these movements with a demonstrated precision of less than one arc second for each measurement of the four recorded motions. These motions are: (1) X_t , translation in the horizontal plane perpendicular to the laser beam, (2) Y_t , translation in the vertical plane, (3) X_r , rotation about the vertical axis, and (4) Y_r , rotation about the horizontal axis. It is felt that this degree of precision will permit the tracking of earth motions closely enough to learn something about their sources and predictability. Most important, such precision should give a valid indication of the degradation of geodetic direction references as a result of these earth movements.

4. DESCRIPTION OF EXPERIMENT

Some of the equipment has been described elsewhere¹ but is repeated here in part for clarity. The system uses a HeNe laser as the collimated light source with a tuning fork to modulate the beam at 400 Hz for detection discrimination. The beam is then expanded to about 10 mm and split into two beams. One beam is used for translation movement detection and one for rotation movement. The laser and optics are mounted on an optical table, with three point suspension, as shown in Figure 3. For one portion of the experiment the reflecting targets are also fixed to an optical table as shown in Figure 4.



Figure 3. Translating and Rotating Equipment

The targets are a cube corner for translation detection, both lateral and vertical, and a flat mirror for rotation detection in both X and Y movements.

1. Wirtanen, T. E., and Mertr, E. M. (1989) Design of a Unique Azimuth Monitoring Device, AFGL-TR-89-0331, AIAA Paper 89-1754, ADN92513.

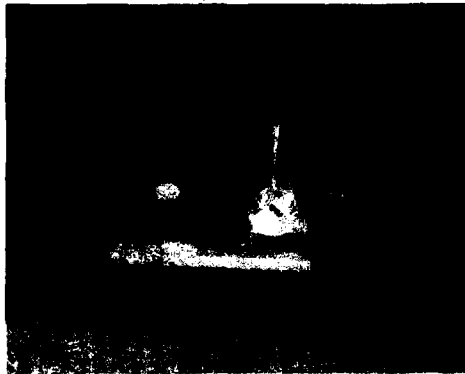

Figure 4. Optical Targets

The equipment, both source and targets, was set up on a stable pier and checked for stability and repeatability. The stability tests showed some drift for about three hours after turn on of the system and then settled to about $5 \mu\text{m}$ of movement which is the noise level. The repeatability tests were performed concurrently with the calibration. This was done by moving the reflector a known amount and recording the amount of movement on the detection/recording system. The repeatability was on the order of $5 \mu\text{m}$. This includes the ability to reset the mechanical displacement micrometers.

The equipment was taken to the New Boston Tracking Station in New Hampshire. This site was chosen because of the availability of piers (left over from WW II) that were separated by the distances of interest.

The first portion of the experiment was to set up the light source and reflectors on two concrete slabs 20.17 m apart. This portion of the experiment was performed inside of a building, the temperature of which fluctuated by only 1°C . The equipment was allowed to "warm up" for four hours before starting to record changes in movement.

The second part of the experiment was to leave the laser and associated optics on the slab and set up the target reflectors outside of the building on a pier located 34.39 m from the slab. Figure 5 shows the tripod used to mount the target reflectors and the doorway where the laser was mounted.

5. DATA RECORDING AND REDUCTION

Data collection is accomplished by means of detecting a change in light position using a biaxial Schottky photodiode, processing the resulting electrical current change through an analog to digital converter and then writing this Binary Coded Decimal (BCD) information on magnetic tape. The magnetic tape is then input to a CDC 6600

computer which in turn outputs the recorded data in either chart form, data listings, or a combination of both.

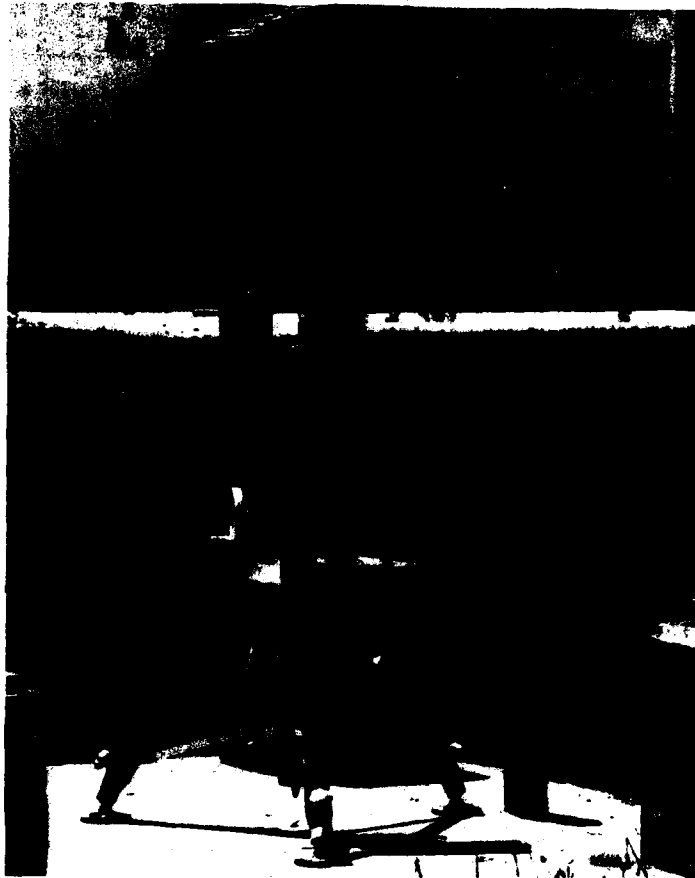

Figure 5. External Target Mount

Main factors in the selection of the Model SC-50 biaxial Schottky barrier photodiode as a light image position sensor for this system were its ability to detect a change in light position in relation to the centroid of its light sensitive surface, its capability to resolve small motion with the provision that any nonlinearity be correctable, plus high repeatability. Figure 6 shows pictorially three different views of the model SC-50 biaxial photodiode. Basically this device has one electrical connection on each of the four sides of its light sensitive surface. Current flows

equally from each connection as long as the light spot is centered on the light sensitive surface. As the centroid of the light image moves away from the center or null point of the sensor a current unbalance occurs. It is this difference in current unbalance that results in a corresponding value for the actual displacement of the light spot centroid from the null position. The following briefly explains signal development using the biaxial Schottky barrier photodiode.

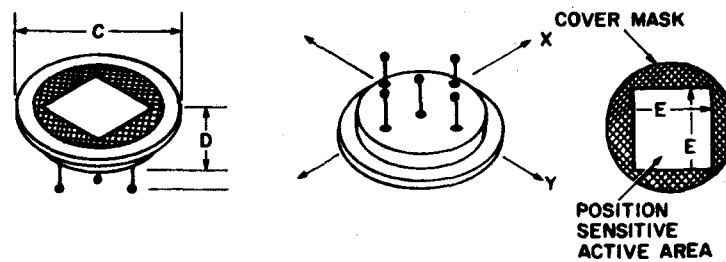

Figure 6. Photodiode

The photodiode is a current source. The preamplifier is a current-to-voltage operational amplifier and the following stage is a difference amplifier which subtracts quadrant voltage signals resulting in a voltage proportional to light spot displacement from center. The difference voltage is proportional to light intensity as well, so if no corrective action were taken the position measurement would vary with intensity. The sum of the two currents is also proportional to light intensity but not to light spot position changes. A straightforward solution is to divide the difference by the sum giving a signal proportional to position but not intensity. Figure 7 shows schematically signal development through one axis of the biaxial photodiode.

Several options are available to us in terms of programs that can be used to sort our data. Basically we use a standard Fortran 4 software package that sorts our data into four specified motions, labels each of these parameters, in column form, with the appropriate channel function at the head of each column. Y_r and X_r are rotational channels, Y_t and X_t are translational channels. This program also keeps a progressive clock count every 23.5 sec from the start of data recording to the finish. The 23.5-sec timing period is the time to sample the four data channels, reset and then repeat this process through the complete recording cycle, which may last as long as eight days. This timing technique has been of significant value since we are able to compare known time events, natural or cultural, with

our data, by allowing us to determine the validity of the events that show up when our data is reduced. After scanning the sorted data listing for minimum and maximum values for each of the four motions, a second program is run giving us scaled plots of the parameters, Y_R , X_R , Y_t and X_t , showing movement (in volts) versus time (in seconds) as shown in Figures 8-11. These plots represent data recorded during a recent field trip and will be discussed in detail later in this report.

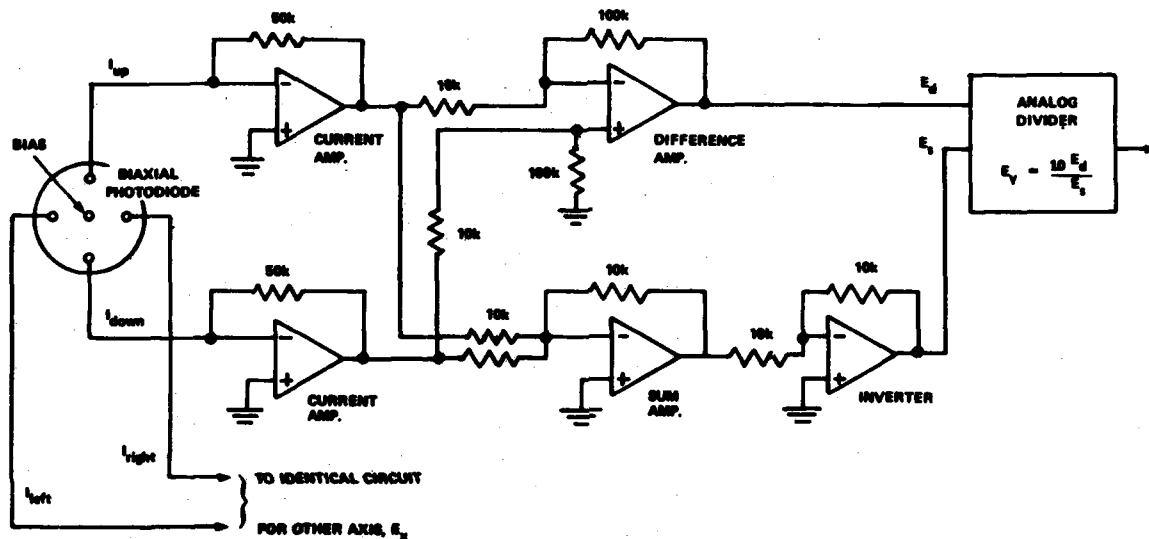

Figure 7. Dual Axis Photodiode Position Sensor

Many options are available to us in data recording, program selection, both listings and plots, and in the techniques used in the actual reduction of our data. Plans were made to update our system to include an on line computer, terminal and printer, giving our system the flexibility necessary to become a self sufficient, operational field apparatus.

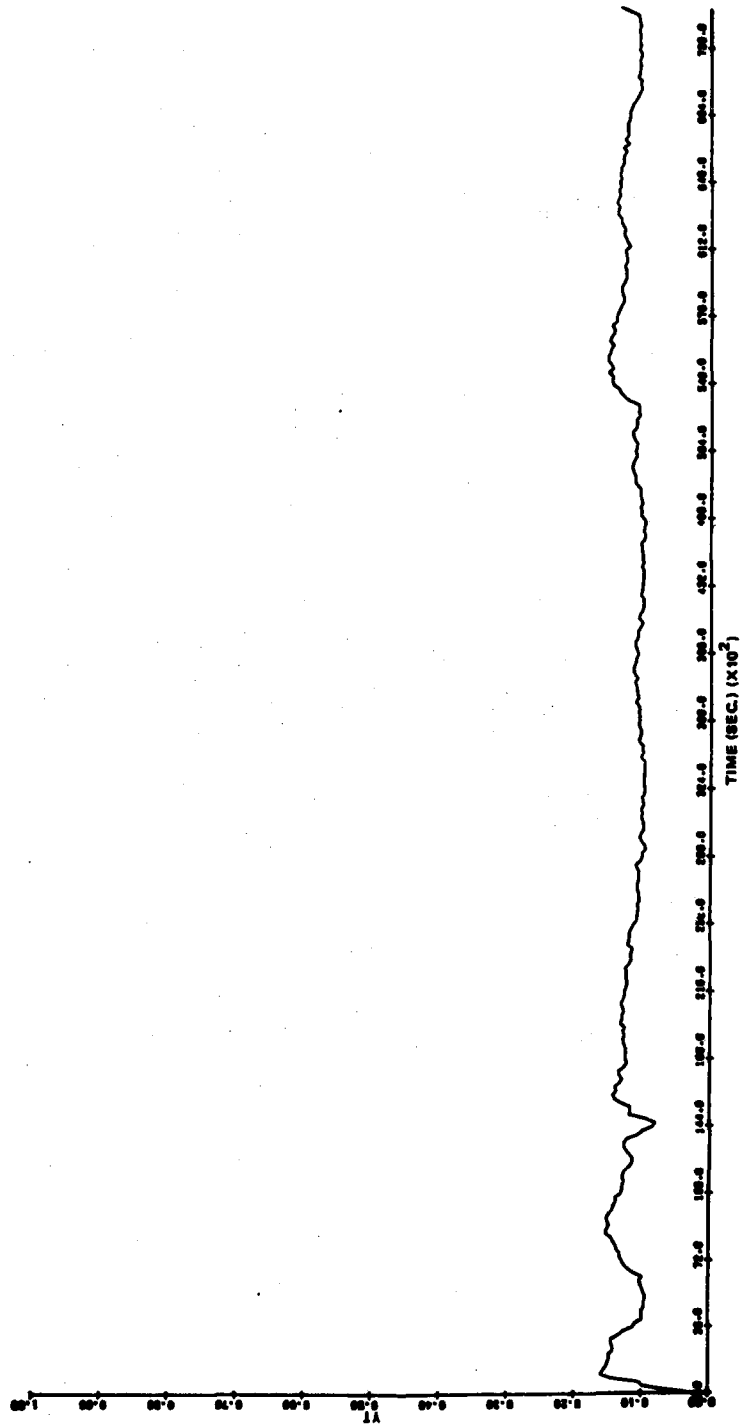

Figure 10. Y Translation Data Plot

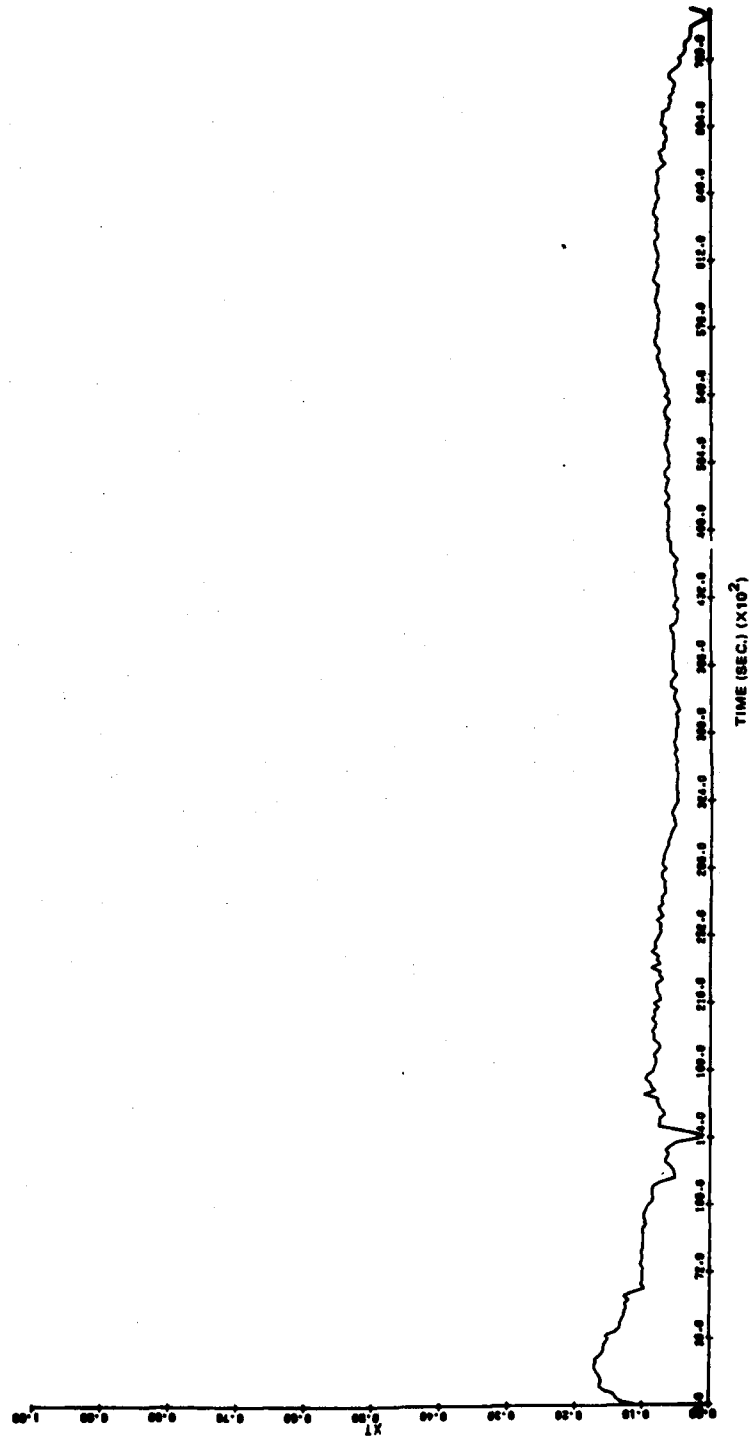

Figure 11. X Translation Data Plot

6. RESULTS

Figure 12 is a computer plot of one of the Y rotational (angular) runs. The following is an explanation of the data. Discounting the first hour to allow for personnel to move far enough away so as not to influence the site, the drift in Y rotational data for the next two hours was 0.710 mm/hr or about 3''/hr. The drift then leveled off to 0.235 mm/hr or about 1''/hr. After seven hours of running time the drift was well under 1''/hr. It should be noted that the large spike seen at about 432×10^2 sec after the start of the run is the result of driving an automobile close (~ 5 m) to the transmitter end of the experiment. As can be seen there is a rather large effect. Again discounting the first hour of the run the X rotation drift was less than 2''/hr for the next three hours. After nine hours the drift settled to about 0''/hr. In both X and Y the drift increased after moving the vehicle but the sun was also coming up so more investigation is required to determine if this is a loading effect or a diurnal cause. The system in its present form did not allow us to observe what the data was like while in the field which would have allowed us to change our approach during the experiment. This, however would be alleviated by integration on an on-line computer.

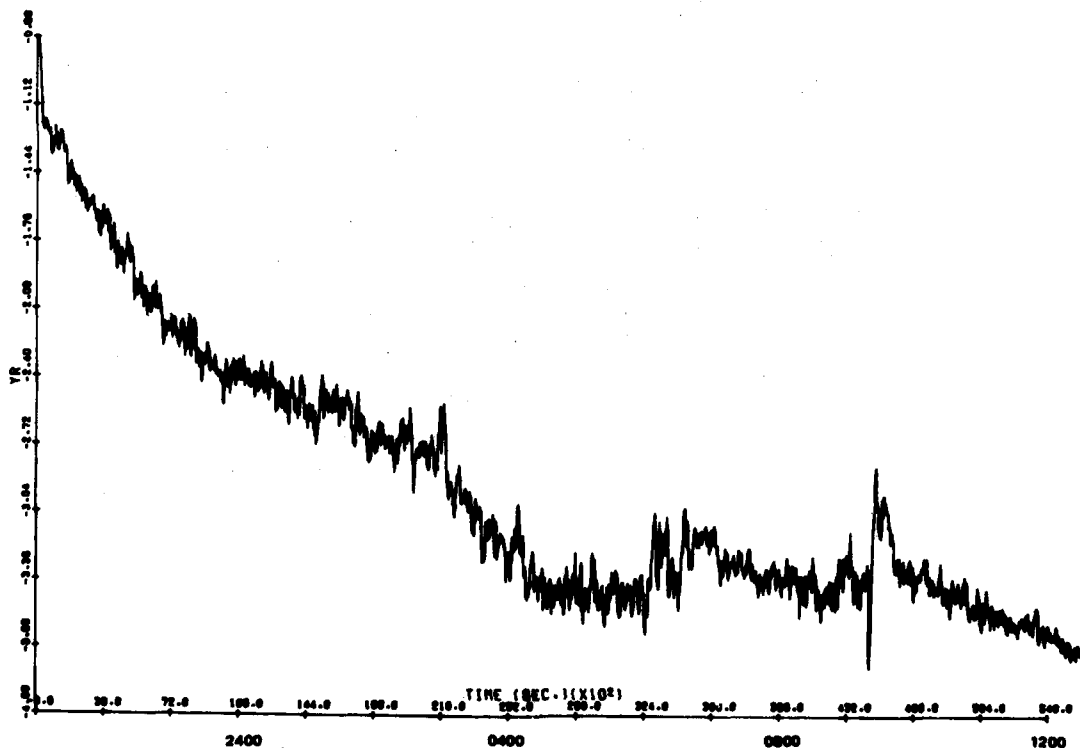

Figure 12. Y Rotational Data Plot

7. SYSTEM RESPONSE LINEARITY

The control module, operating in accordance with the manufacturer's instructions,² requires an adjustment of the sum voltage into the analog divider. This adjustment should be such that a 1-mm linear displacement of the image centroid on the face of the receiver produces a 1 V change in the output signal. This displacement is really non-linear, as Figure 13 shows. The earliest tests of the system's nonlinearity² indicated a response curve of $\pm Y_t = Y_m \pm 0.01 (Y_m)^2$,⁴ where Y_m are measured values in mm of a motion quantity (in this instance Y_{Trans}) and Y_t is the known amount of translation, introduced manually to the mirror mounting. This conversion results in errors less than 0.01 mm within a 6-mm radius from the center point of the junction barrier diode. The experiments performed at AFGL to establish response linearity produced the data shown in Figure 14. From these values we calculated a response voltage/versus centroid movement for direct (non-reflected) reception of an image. These data yield the polynomial

$$Y_t = 0.115 + 2.430Y_m - 0.051Y_m^2 - 0.039Y_m^3.$$

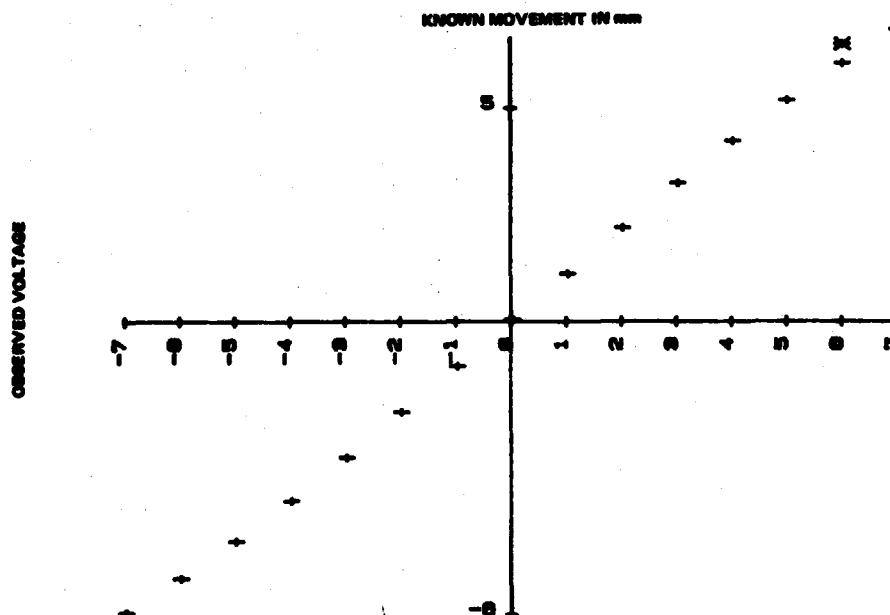

Figure 13. Photodiode Calibration Plot

2. Morse, E. P. (177) A Dual Electro-Optical Light Image Receiver and Recorder, AFGL-TR-77-0002, final report, Contract F19628-76-C-0206, ADA037955.

MOVEMENT X_{mm} \bar{X}	VOLTAGE \bar{V}	MOVEMENT $-X_{mm}$ \bar{X}	VOLTAGE \bar{V}
0	0.05	-0	0.005
0.5	0.51	-0.5	-0.50
1	1.01	-1	-1.01
2	2.00	-2	-2.02
3	2.98	-3	-2.995
4	3.88	-4	-3.93
5	4.75	-5	-4.81
6	5.55	-6	-5.62
7	6.32	-7	-6.36

Figure 14. Photodiode Calibration Data

A spectral analysis of the stability data at frequencies of 1 cycle per 10 min and lower does not show any marked periodicity (Figures 15-18). The diurnal effects acted equally on the transmitting and receiving optics as set up in this experiment and are not recorded as degradations of the instrument/system sensitivity. System sensitivity is in the millivolt range with no meaningful equipment drift shown over the 5-day interval.

8. CONCLUSIONS

The azimuth monitoring technique, in its prototype form, has shown a potential for sensing and recording sub-arcsecond rotational and translational movements of azimuth reference stations. Measurement and system stabilities are acceptable for the system to meet such precision requirements. The non-linearity and repeatability of voltage response to image centroid movement can be simulated with a polynomial to within 0.02 mm. This is also adequate to meet system objectives. Sample integration time of 15 sec minimizes atmospheric effects on image shimmer and beam wander.

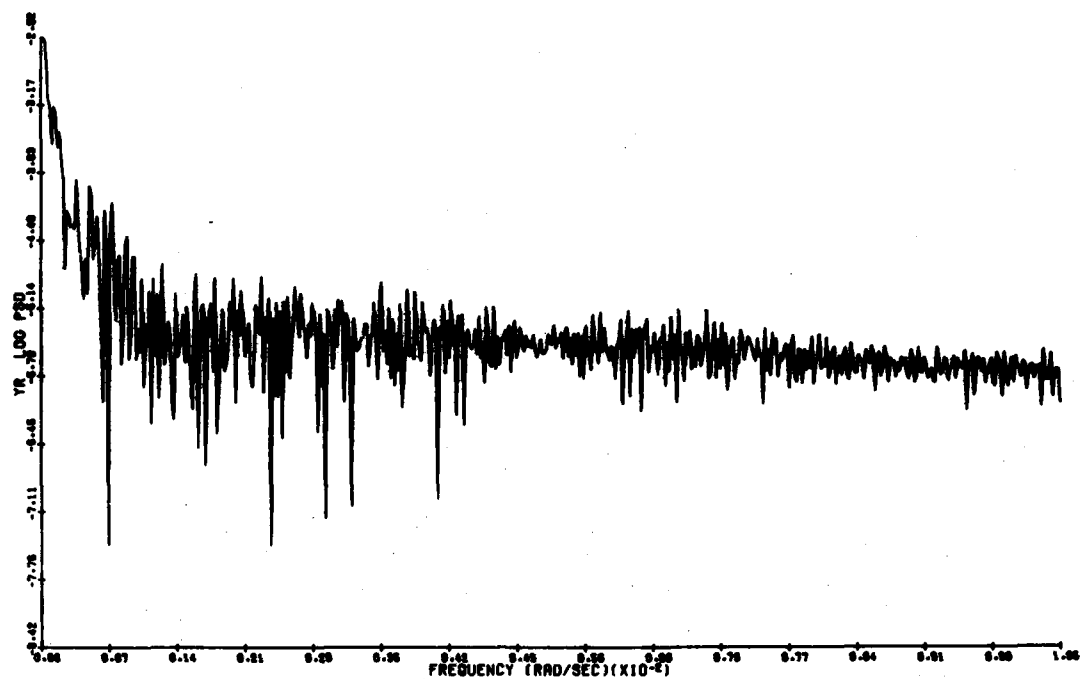

Figure 15. Spectral Analysis, Y Rotation

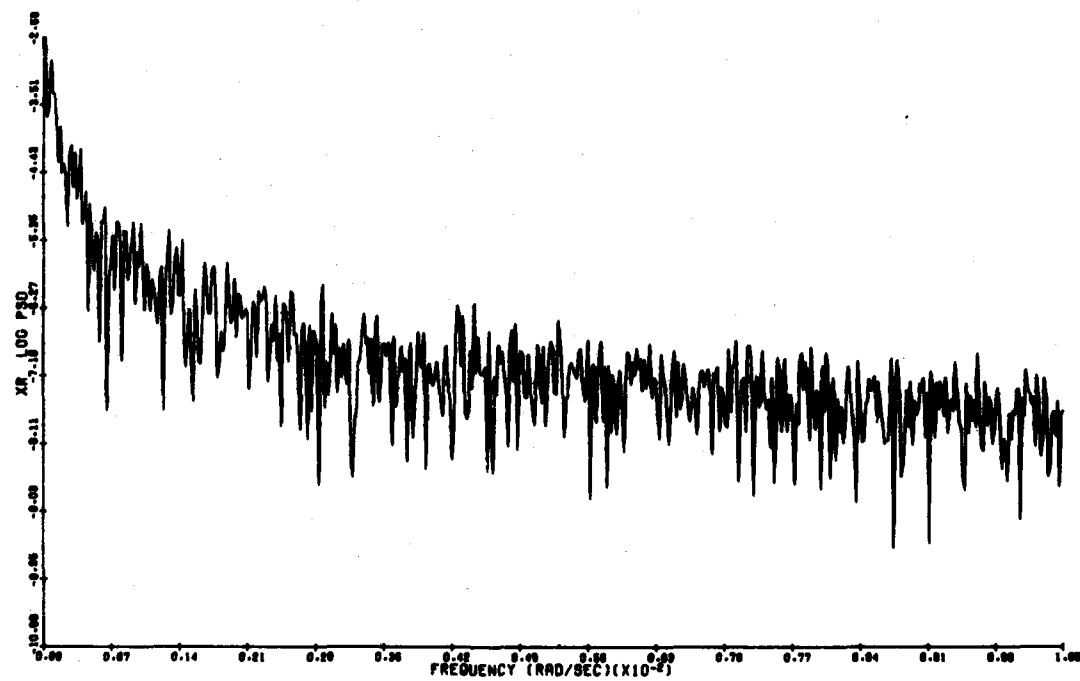

Figure 16. Spectral Analysis, X Rotation

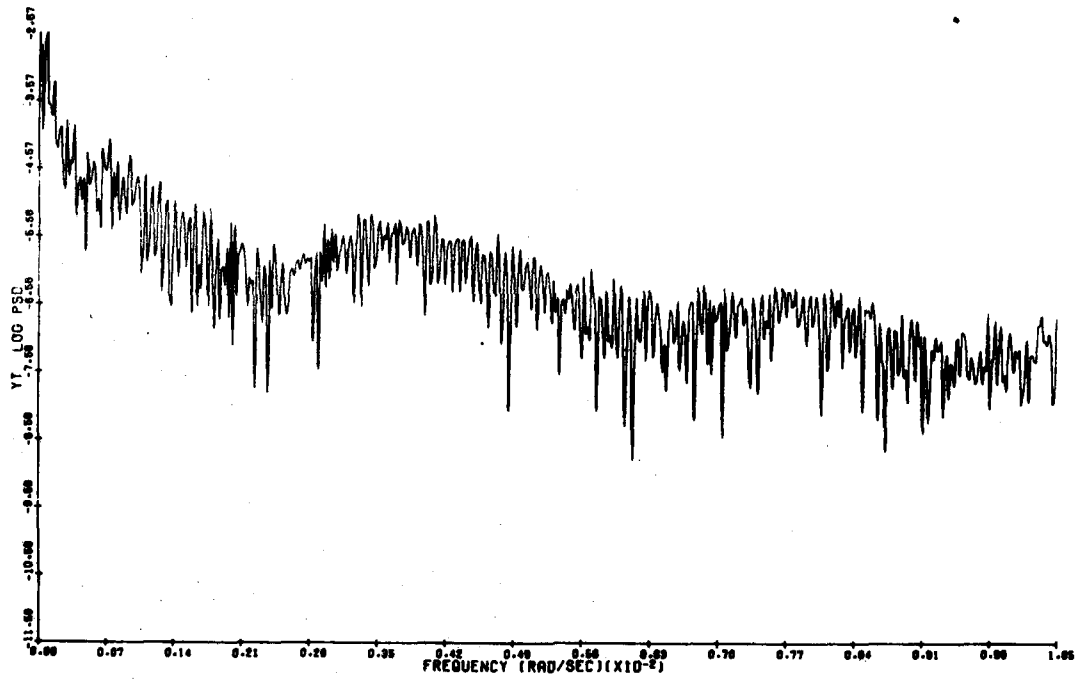

Figure 17. Spectral Analysis, Y Translation

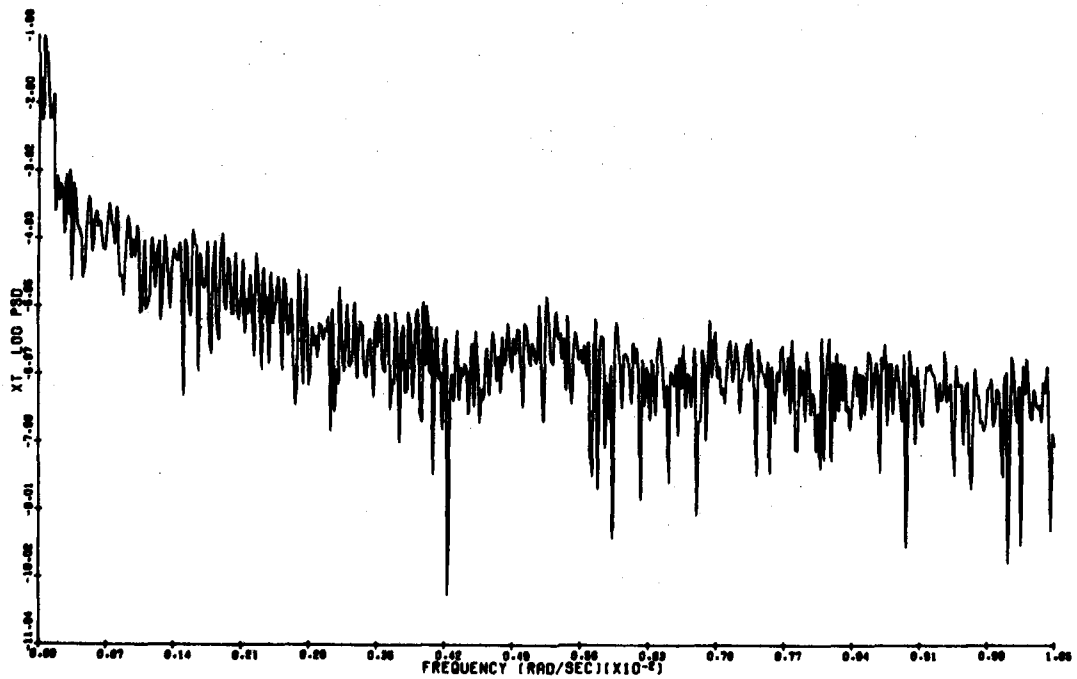

Figure 18. Spectral Analysis, X Translation