

AD-A120 849

DISPOSAL OF CHEMICAL AGENT IDENTIFICATION SETS AT ROCKY  
MOUNTAIN ARSENAL. (U) ARMY TOXIC AND HAZARDOUS  
MATERIALS AGENCY ABERDEEN PROVING GR.  
W R BRANKOWITZ ET AL. JUL 82

1/2

UNCLASSIFIED

F/G 15/2

NL

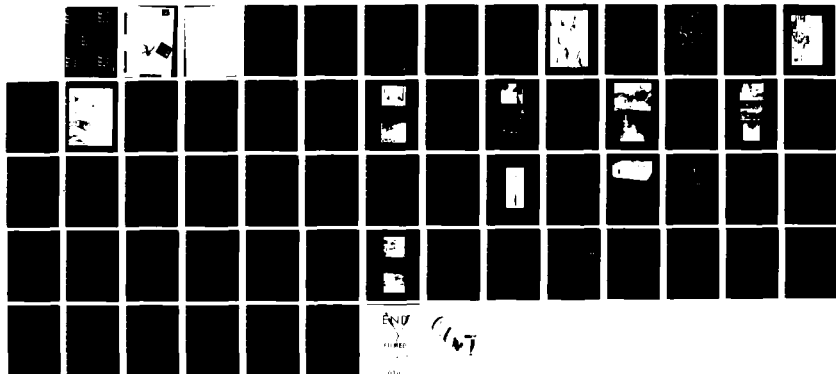

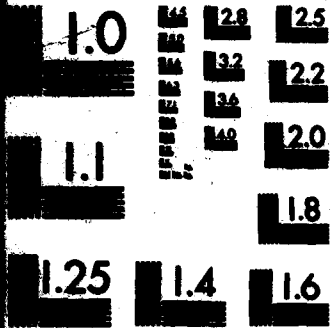

MICROCOPY RESOLUTION TEST CHART  
NATIONAL BUREAU OF STANDARDS-1963-A

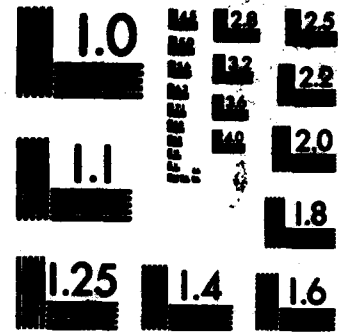

MICROCOPY RESOLUTION TEST CHART  
NATIONAL BUREAU OF STANDARDS-1963-A

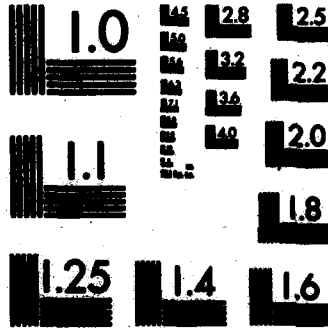

MICROCOPY RESOLUTION TEST CHART  
NATIONAL BUREAU OF STANDARDS-1963-A

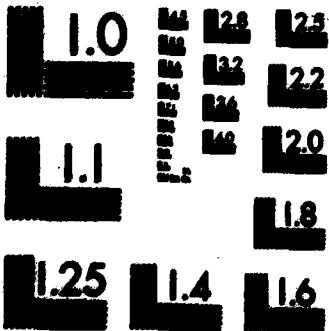

MICROCOPY RESOLUTION TEST CHART  
NATIONAL BUREAU OF STANDARDS-1963-A

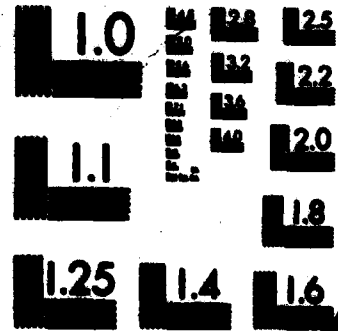

MICROCOPY RESOLUTION TEST CHART  
NATIONAL BUREAU OF STANDARDS-1963-A



DISPOSAL OF CHEMICAL AGENT IDENTIFICATION SETS  
AT ROCKY MOUNTAIN ARSENAL, COLORADO

MUSTARD OPERATIONS: PHASE 1  
FINAL REPORT

Prepared By  
William R. Brankowitz  
USATHAMA

Dr. Michael E. Witt  
RMA

John A. Ursillo  
RMA

Dr. Jack C. Pantler  
Data Processing Associates

JULY 1982



DISTRIBUTION UNLIMITED. CLEARED FOR PUBLIC RELEASE

DEPARTMENT OF THE ARMY  
US ARMY TOXIC AND HAZARDOUS MATERIALS AGENCY  
ABERDEEN PROVING GROUND, MARYLAND 21010

82 10 29 024

Unclassified

SECURITY CLASSIFICATION OF THIS PAGE (When Data Entered)

REPORT DOCUMENTATION PAGE		READ INSTRUCTIONS BEFORE COMPLETING FORM
1. REPORT NUMBER DRXTH-SE-FR-82163	2. GOVT ACCESSION NO. AD-4120 F49	3. RECIPIENT'S CATALOG NUMBER
4. TITLE (and Subtitle) MUSTARD OPERATIONS: PHASE I FINAL REPORT DISPOSAL OF CHEMICAL AGENT IDENTIFICATION SETS At Rocky Mountain Arsenal, Colorado	5. TYPE OF REPORT & PERIOD COVERED Final Operations Report 8 May 1981 - 28 Jan 1982	
	6. PERFORMING ORG. REPORT NUMBER	
7. AUTHOR(s) Mr. William R. Brankowitz, Dr. Jack C. Pantleo, Mr. John A. Ursillo, and Dr. Michael E. Witt	8. CONTRACT OR GRANT NUMBER(s)	
9. PERFORMING ORGANIZATION NAME AND ADDRESS Rocky Mountain Arsenal, Commerce City, Colorado and US Army Toxic & Hazardous Material Agency, Aberdeen Pro Grd, MD	10. PROGRAM ELEMENT, PROJECT, TASK AREA & WORK UNIT NUMBERS	
11. CONTROLLING OFFICE NAME AND ADDRESS US Army Toxic & Hazardous Materials Agency Aberdeen Proving Ground, MD	12. REPORT DATE July 1982	
	13. NUMBER OF PAGES 56	
14. MONITORING AGENCY NAME & ADDRESS (if different from Controlling Office)  NA	15. SECURITY CLASS. (of this report)  Unclassified	
	15a. DECLASSIFICATION/DOWNGRADING SCHEDULE	
16. DISTRIBUTION STATEMENT (of this Report)  <div style="border: 1px solid black; padding: 5px; text-align: center;">           APPROVED FOR PUBLIC RELEASE            Distribution Unlimited         </div>		
17. DISTRIBUTION STATEMENT (of the abstract entered in Block 20, if different from Report)		
18. SUPPLEMENTARY NOTES		
19. KEY WORDS (Continue on reverse side if necessary and identify by block number)		
Chemical Agent Identification Set (CAIS) Rocky Mountain Arsenal (RMA) Demilitarization K941/K942 Set Data Analysis	X-Type Set Incineration Waste Disposal Mustard Downtime	Air Monitoring SF6 Tracer Gas Mustard Wet Chemistry Analysis Quality Control-Chemical Analysis
20. ABSTRACT (Continue on reverse side if necessary and identify by block number)		
<p>This report covers the demilitarization and disposal activities carried on in the Chemical Agent Identification Sets Disposal Plant from 8 May 1981 through 28 January 1982. This portion of the operations destroyed all sets containing only the chemical warfare agent mustard. The report summarizes operations, air monitoring and laboratory efforts and data collection and analysis methods. It provides a concise history in terms of inventory, air monitoring and downtime of the mustard disposal portion of the project.</p>		

## **Acknowledgements**

**A special acknowledgement is made to Mr. Jim White of Stearns-Roger Inc. for his significant contributions to this report.**

**The assistance of the following in providing review and input to the report is also acknowledged:**

**Mr. Jim Clark  
Mr. Dan Wilcox  
Mr. Larry Dale  
Mr. Elijah Jones  
Mr. Jim Mullins  
Mr. Gene Crabtree**

**DP Associates  
DP Associates  
RMA  
RMA  
RMA  
RMA**

# CONTENTS

## CHAPTER 1 PROCESS DESCRIPTION

- 1.1 Purpose
- 1.2 Disposal Procedures
  - 1.2.1 Transportation from Interim Storage
  - 1.2.2 Pig Sets
  - 1.2.3 Box Sets
- 1.3 Waste Disposal

## CHAPTER 2 PRODUCTION SUMMARY

- 2.1 Set Descriptions
- 2.2 Numerical Summary of Sets Destroyed - By Day
- 2.3 Numerical Summary of Waste Generated
- 2.4 Downtime Synopsis By Day and By Subsystem

## CHAPTER 3 AIR MONITORING SUMMARY

- 3.1 Description of Sampling Technique
- 3.2 Description of Analysis Technique
- 3.3 Summary of Standards to Be Maintained
- 3.4 Summary of Air Monitoring Readings by Day

## CHAPTER 4 DATA COLLECTION AND QUALITY CONTROL

- 4.1 Method of Data Collection
- 4.2 Description of Air Monitoring Data Analysis
- 4.3 Description of Inventory Data Collection
- 4.4 Description of Downtime Data Collection

## CHAPTER 5 CONCLUSIONS

- 5.1 Introduction
- 5.2 Plant Operations
  - 5.2.1 General
  - 5.2.2 Air Monitoring Results
  - 5.2.3 Disassembly Room Operations and Set Characteristics
  - 5.2.4 Downtime Analysis



Accession For	
NTIS GRA&I	<input checked="" type="checkbox"/>
DTIC TAB	<input type="checkbox"/>
Unannounced	<input type="checkbox"/>
Justification	
By _____	
Distribution/	
Availability Codes	
Dist	Avail and/or Special
A	

## LIST OF FIGURES

1	ID Sets Demilitarization Program, Building 1611
2	CAIS Facility Site Layout
3	Chemical Agent Identification Sets, Demilitarization Facility
4	Disassembly/Storage Glovebox
5	Screw Conveyor and Feed Chute Locations
6	Disassembly Glovebox and Decontamination Module
7	ID Sets Process Flow Diagram - K941/K942
8	Pigs Being Deposited in Decontamination Furnace
9	Pigs After Decontamination
10	ID Sets Process Flow Diagram - X Sets
11	Box Feed Chute
12	Residue Handling Equipment
13	Electrostatic Precipitator
14	Spray Dryer
15	Identification and Training Sets
16	Toxic Gas Set K941
17	Gas Set Identification, Instructional, X-Sets
18	Typical Mustard Bubbler
19	Sampling Station Locations, Bldg 1611
20	SF <sub>6</sub> Detector/Analyzer
21	SF <sub>6</sub> Flow Diagram
22	Dynascience Monitor, Bldg 1611 Stack
23	Data Collection Flow Chart
24	Laboratory Equipment
25	Data Processing Equipment
26	Calibration Instrument Response
27	Actual Data for H Report
28	Accuracy Control Chart for H
29	Precision Control Chart for H

## LIST OF TABLES

1	Numerical Summary of Sets Destroyed by Day
2	Numerical Summary of Waste Generated
3	Downtime Synopsis By Day and By Subsystem
4	Work Area Readings
5	Stack Readings
6	Downtime Analysis By Sets Destroyed

## **CHAPTER 1 PROCESS DESCRIPTION**

### **1.1 PURPOSE**

The purpose of the Mustard Phase (Phase 1) of the Chemical Agent Identification Sets (CAIS) Demilitarization Program was to completely dispose of all CAIS containing only mustard agent. The types of sets to be destroyed were: pig sets K941 and K942, and box sets X302, X547, X550, and X551. The reader is referred to Chapter 2 for a detailed description of the contents of these sets. Disposal of Phase 1 sets was performed in Building 1611 at Rocky Mountain Arsenal (RMA), Denver, Colorado (see Figure 1), commencing 8 May 1981 and concluding 28 January 1982.

### **1.2 DISPOSAL PROCEDURES**

#### **1.2.1 TRANSPORTATION FROM INTERIM STORAGE**

The Chemical Agent Identification Sets for Phase 1 were shipped to RMA as part of SETCON II. The sets were then stored in sheds at the toxic storage yard. They were stored on pallets (16 to 25 pigs or 40 boxes) and lethal X sets were stored in CNU-80 shipping containers (20 in each). Containers were arranged in order of planned disposal.

The sets were loaded on trucks and transported approximately two miles by convoy on paved roads, during daylight hours, from the toxic storage yard to Bldg. 1611. The demilitarization site layout is shown on Figure 2. A maximum of four containers were loaded by forklift onto a stake body truck and blocked and braced into place. The truck bed was equipped with two roller conveyors, length-wise, so the pallets could be loaded from the rear. Convoy speed was held at 10 mph or less during transportation.

Sets arrived at the covered unloading dock, located on the east end of Bldg. 1611. The sets were unloaded and held in the supply conveyor room until they were ready for processing. No sets were held in the building overnight. In the disassembly room, the shipping containers or pallets were moved to the box feed chute or to the disassembly module for processing.

#### **1.2.2 DISASSEMBLY AND DISPOSAL OF PIG SETS**

##### **1.2.2.1 Equipment Description**

The Chemical Agent Identification Set operation was designed and constructed to reduce personnel contact with chemical agents by reducing the disassembly of sets to a minimum. The K941 and K942 sets were packaged and transported in steel shipping containers referred to as "pigs." These pigs were opened in a glovebox, and the six cans inside were removed. Then the ends of the six cans, each containing four bottles of mustard were opened, the material overpacked, and the overpack was inserted into the deactivation furnace. Figure 3 illustrates the system used for the processing of K941 and K942 sets.

A-382.128



Figure 1 ID SETS DEMILITARIZATION PROGRAM, BUILDING 1611

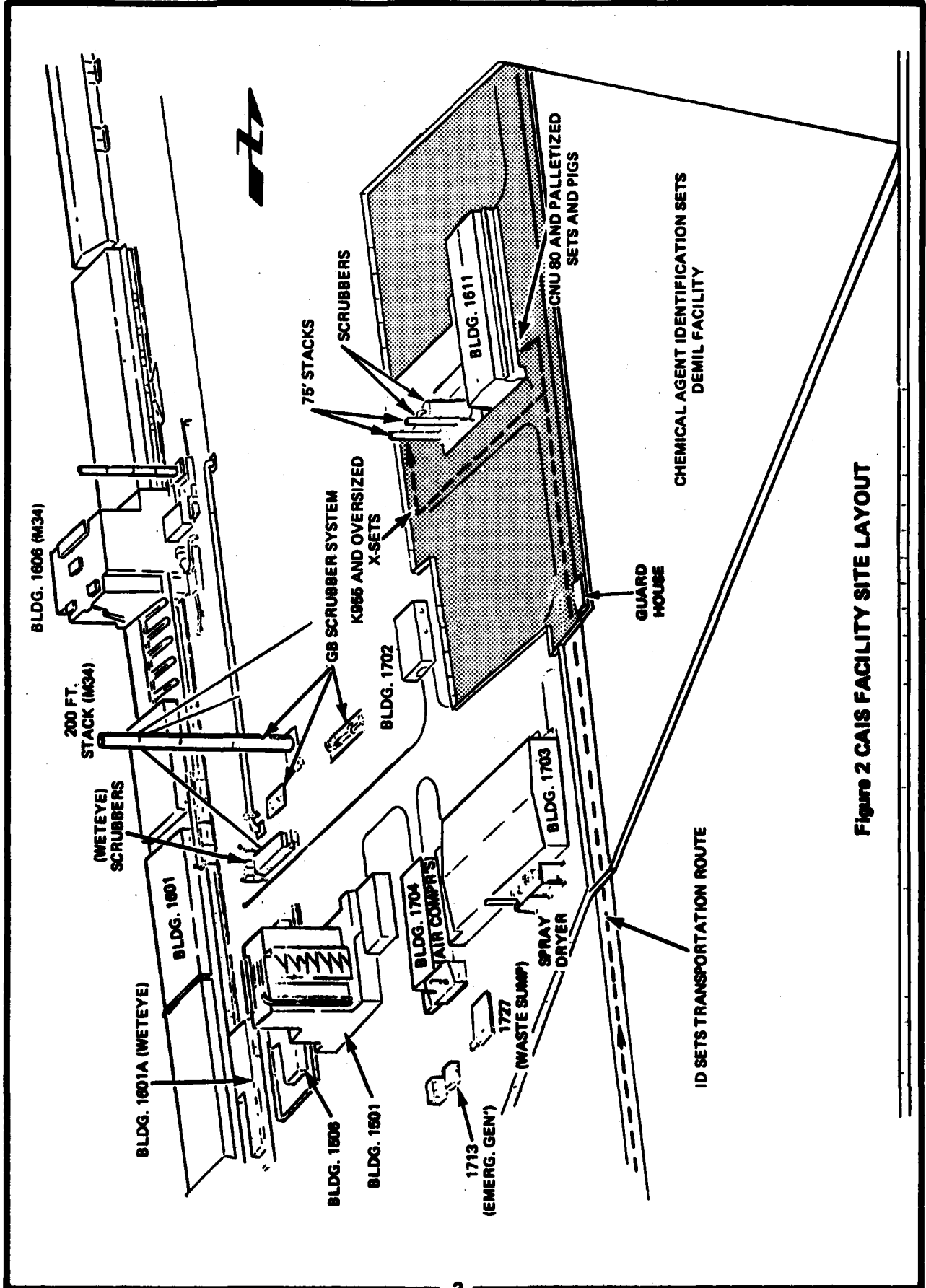

Figure 2 CAIS FACILITY SITE LAYOUT

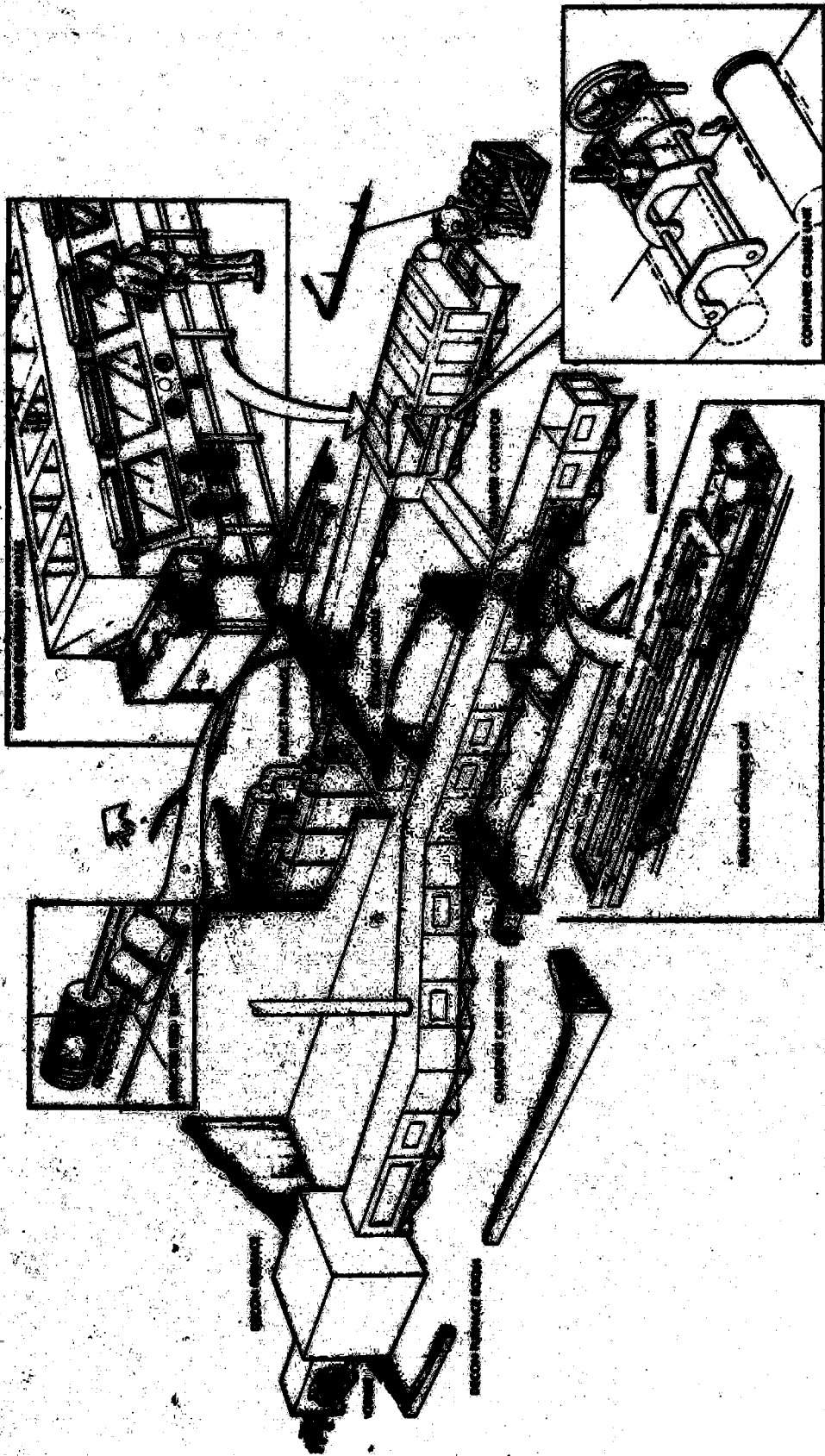

Figure 3 CHEMICAL AGENT IDENTIFICATION SETS, DEMILITARIZATION FACILITY

The glovebox used for disassembly and feeding of Chemical Agent Identification Set hazardous materials consists of two modules sealed to form a single integral unit (see Figure 4). These are referred to herein as the disassembly module and the storage/feed module.

The disassembly module consists of five work stations for the disassembly of the steel cylinders and the removal of set material. This section is approximately 20 feet in length. Two glove ports are provided at each work station to provide access within the glovebox. An opening at the back of each station is controlled by an iris valve and permits entry and exit of the steel cylinder. Electrical interlocks are provided so that only one cylinder at a time is allowed to be entered or discharged from the glovebox. A screw type conveyor, as shown in Figure 5, is provided for the transport of material to the storage/feed module portion of the glovebox. This glovebox has a maximum disassembly rate of 20 sets per hour.

The storage/feed module, approximately 24 feet in length, consists of one operational station at the end of the storage area for inserting materials through a feed device directly into the deactivation furnace. Two gloveports are used in the feeding of set materials. In addition to these gloveports, eight sets of gloveports are provided evenly spaced along the length of the glovebox on one side, for access throughout the box, if required. Under normal operating conditions, these gloveports are sealed. Temporary storage of set cans is provided throughout the length of the glovebox as items are conveyed on the screw type conveyor from the disassembly section. The screw type conveyor has a storage capacity of at least 40 cans. Storage for additional cans is readily available by removing the cans from the conveyor and placing them on the floor of the storage/feed module.

The glovebox is maintained at a negative pressure of approximately 0.8" H<sub>2</sub>O with respect to the disassembly room, and has sufficient air flow to provide a minimum of 25 air changes per hour and surface interface velocity of 150 fpm. Potentially contaminated air is swept through the glovebox and exhausted as part of the air supplied to the afterburner. Fail-safe indicating lamps, and emergency conveyor stops are provided to assure safe operations.

For transporting the ID set shipping containers to and from the disassembly module, a shroud, referred to herein as the decontamination module shroud (Figure 6), parallels the disassembly room, to and through air lock #3, and then is sealed to the entrance door of the decontamination furnace. Within the shroud is a belt drive to transport pigs from the pallet to each disassembly station in the disassembly glovebox.

After disassembly, the containers are transported within the shroud to a decontamination furnace charging cart. The chain-driven charging cart, with a carrying capacity of 12 empty containers, runs on a track within the shroud from the disassembly room to the decontamination furnace. There it unloads the containers on a pedestal within the decontamination furnace. Another charging cart on the opposite end of the furnace is used to remove the containers after they have been thermally decontaminated. All operations in the shroud are done remotely using push-button electric/pneumatic actuated devices. This shroud also has the capacity to store up to 36 containers.

A-3.82.128

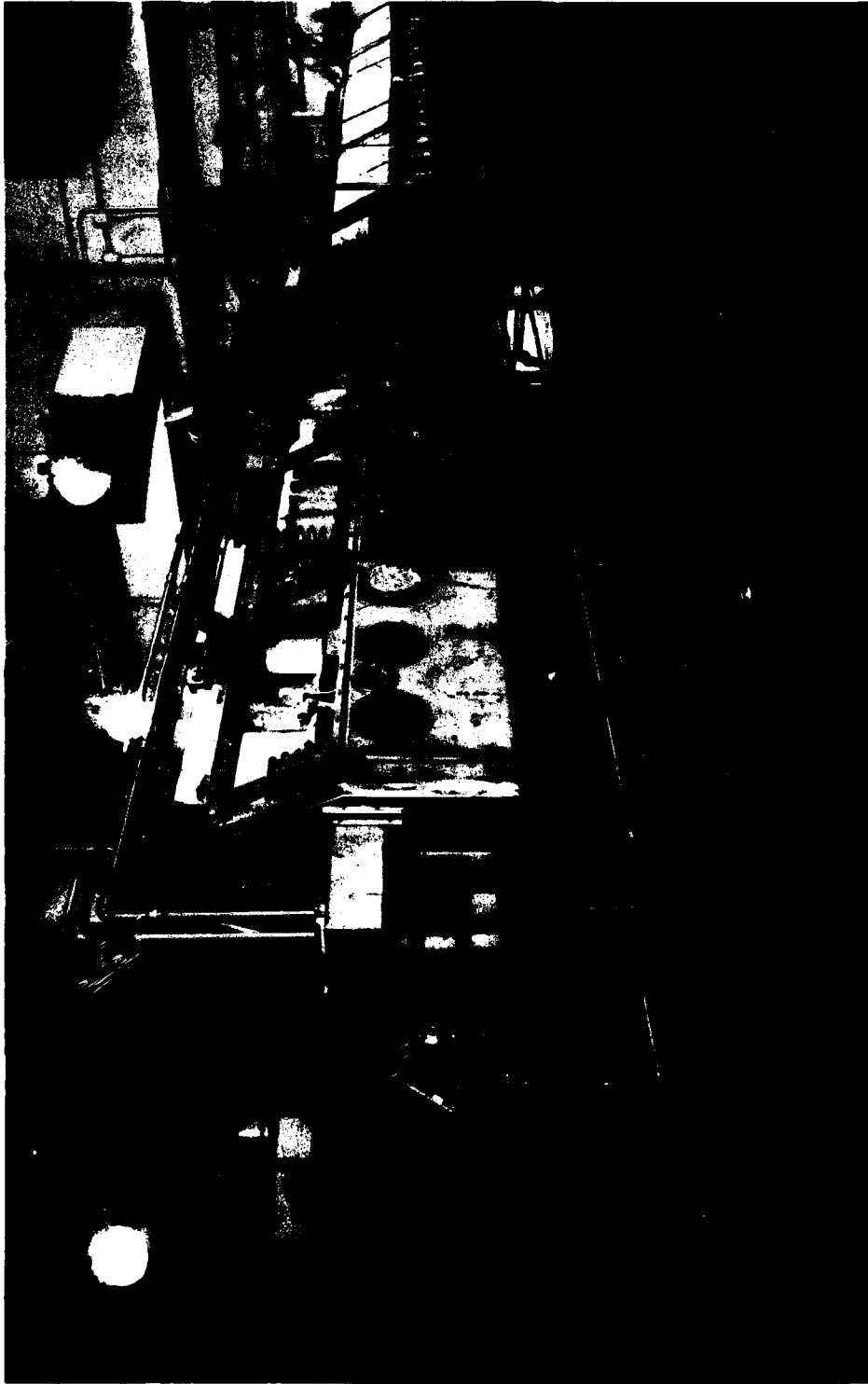

Figure 4 DISASSEMBLY/STORAGE GLOVEBOX

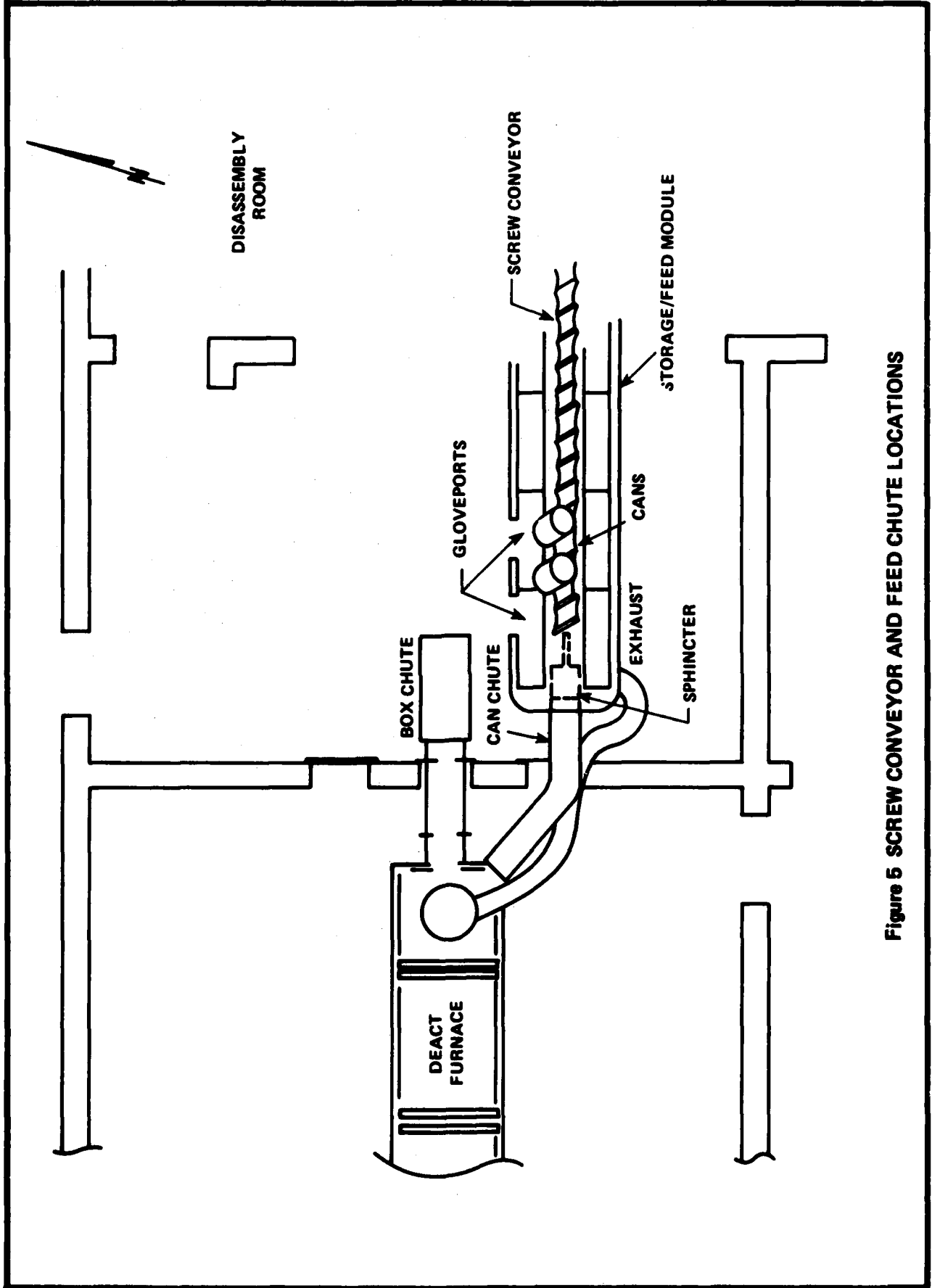

Figure 5 SCREW CONVEYOR AND FEED CHUTE LOCATIONS



Figure 6 DISASSEMBLY GLOVEBOX AND DECONTAMINATION MODULE

The decontamination module is kept under a negative pressure (approximately 0.1" H<sub>2</sub>O) and sufficient air flow to provide a minimum of 25 air changes per hour with an air flow face velocity at all openings of 150 fpm minimum. The decontamination module shroud is connected to the building exhaust air system with room air being drawn through the pig load station (air flow within the shroud in the direction of the decontamination furnace). An air lock, approximately the length of the charging cart, is used on both sides of the decontamination furnace to prevent furnace flameouts when the furnace door is opened.

Handling of the shipping containers (pigs) within the shroud is accomplished by means of a cradle mechanism to lift the pig from the shroud transport conveyor into place in the disassembly module. Remote pushbutton controls are installed at each work station to assist operators in working pneumatic hardware. Some operations feature logic sequencing as well as overload stops to assure safe operations while working in and around the equipment.

A process flow diagram for disassembly and feeding of K941 and K942 sets in metal shipping containers is shown in Figure 7.

#### 1.2.2.2 Process Description

To start operations, steel cylinder pigs were removed from their pallet using an overhead crane. The pigs were then placed on a load tray adjacent to the air inlet to the decontamination module shroud. The operator then pressed a button marked LOAD and several sequenced functions took place. They were as follows:

- a. When a container (pig) was required at a disassembly station, stops located at the appropriate disassembly station were raised slightly above the surface of the belt.
- b. A pig was lowered into the decontamination module onto a continuously moving conveyor. When the pig reached the stops at the disassembly station, its forward motion ceased.
- c. The stops raised the pig into the jaws of the cradle clamp.
- d. The jaws closed and firmly gripped the pig.
- e. The stops returned below the top surface of the belt; concurrently, the iris was opened.
- f. The cradle was pushed toward the disassembly glovebox until the head of the pig was approximately six inches inside the glovebox.
- g. The iris valve closed.
- h. The disassembly operations began.

The disassembly operator, working through gloveports, removed the cans from the pig and resealed the pig with a rubber gasket. The eight bolts, lid and lead gasket were removed and set aside. The cylinder was remotely tipped 35 degrees, to facilitate removal of the cans from the cylinder. The cans were removed one at a time and placed on a screw-type conveyor which transported them through the disassembly module to the storage/feed module. Cans which were ruptured or rusty, or loose ampules/trash, were packed into a fiberboard overpack prior to being placed on the conveyor. The steel cylinder was then inspected to assure all agent containers (cans) were removed. Cans stuck in the the shipping container were removed using a special rotary motion tool that reached up into the shipping container and

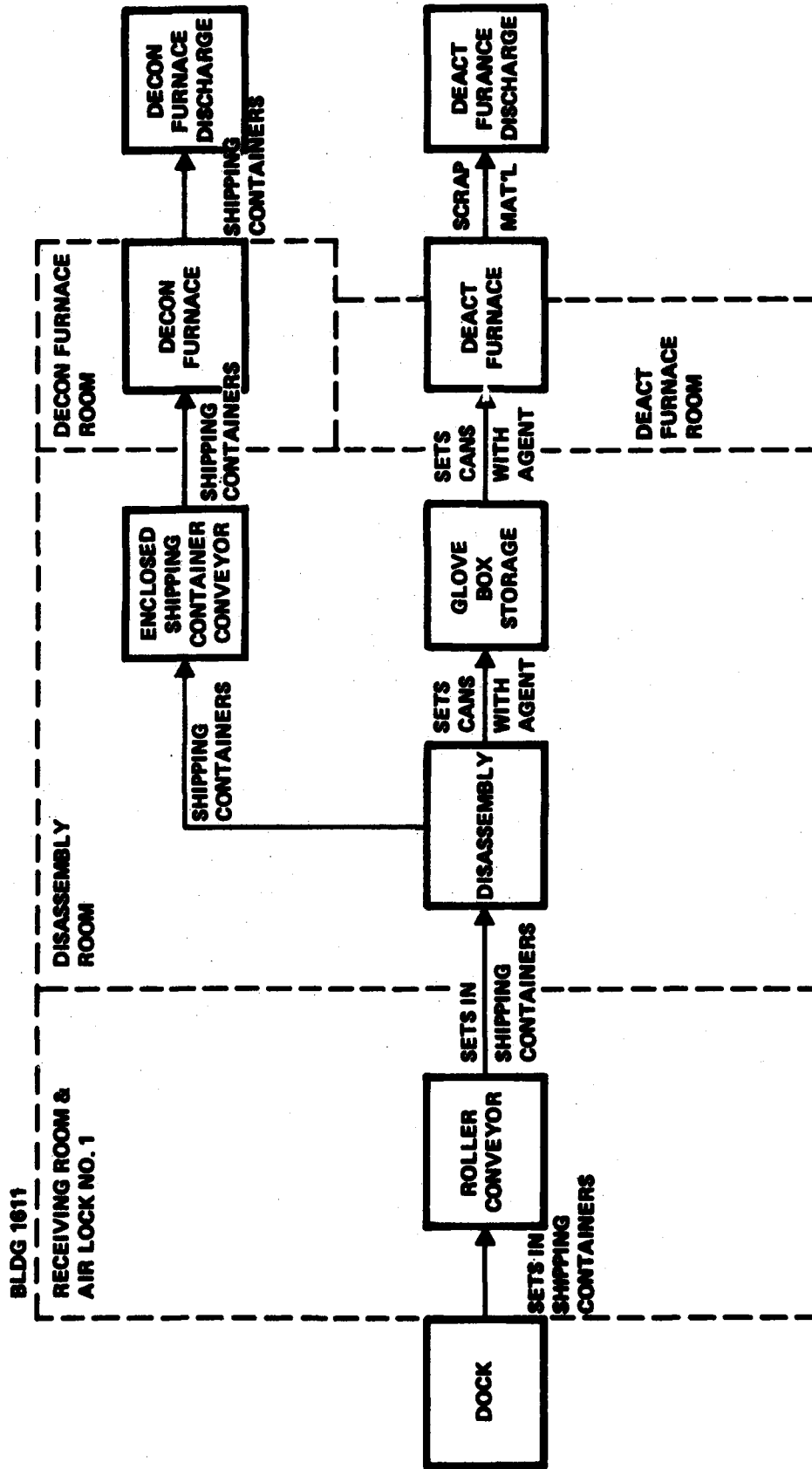

Figure 7 ID SETS PROCESS FLOW DIAGRAM - K941/K942

removed or scraped the can free. After it had been certified that all cans had been removed from the shipping container, the lead gaskets from two containers, or 12 bolts were inserted into the container. The lid of the container was reassembled using a consumable rubber gasket in place of the lead gasket and the two remaining bolts. Excess bolts and lead gaskets were not disposed of in the same container.

The operator inspected for any contamination, and if required, brushed that portion of the pig with methylcellosolve/caustic for decontamination. The work area was also decontaminated if required. The trash generated during decontamination was placed in an overpack and then inserted into the deactivation furnace. The QA inspector then used a key release to allow the decontamination module operator to remove this empty container and to supply a fresh one.

Concurrent with disassembly operations, cans were inserted into the deactivation furnace at the rate of one per minute. They were inserted from the west end of the storage/feed module into the deactivation furnace through a sphincter feed system as previously shown in Figure 5. This system used a can held by two rubber sleeves to seal the feed chute. As a can was pushed into the sphincter, it replaced the previous can, thus retaining the integrity of the seal. The cans were pushed through the sphincter and into the feed tube using a pneumatic ram controlled by a preset timer.

An operator, working through gloveports, removed a can from the conveyor and placed it on the sphincter loading tray. After 60 seconds had elapsed from the feeding of the previous can, the station became operational and the next can could be fed. The last can to be fed was an empty can which was used to push out the previous agent filled can and seal the feed tube until the next operational period.

Prior to removal of an emptied pig from the disassembly module, the decontamination module operator received a green light signal from the QA inspector's key control on the disassembly glovebox. He then pressed the unload button at that station and the following sequence took place:

- a. The iris opened.
- b. The pig was pulled out of the glovebox.
- c. The iris closed and simultaneously stops raised up and rested against the pig.
- d. The jaws of the clamp opened releasing the pig.
- e. The stops descended leaving the pig unobstructed on the moving conveyor belt.

This conveyor transported the pig to a transfer conveyor which moved it onto an intermediate holding table. The holding table has a capacity to hold 24 empty pigs. The intermediate table was manually indexed to provide room for the pigs as they came off the conveyor and also for positioning pigs onto the decontamination furnace charging cart. The transfer conveyor, the intermediate table, and path to the decontamination furnace are enclosed in a shroud which was purged by air coming from the end of the decontamination module and the load station.

When there were 12 pigs on the table, the charging cart operator, located in the disassembly room, positioned the motorized charging cart under the 12 containers. He then raised the cart up and lifted the 12 containers off the intermediate table. He then started a load sequence which automatically conveyed the pigs through the

furnace room to the decontamination furnace door, where the cart stopped. A door closed behind the cart isolating the cart from the shroud thus forming an air lock. At this point, controls were operated to open the furnace door and start the final portion of the load sequence into the furnace. When the cart reached the opposite end, the cart stopped and lowered leaving the pigs to rest on firebrick pedestals (Figure 8). The cart then retracted, the furnace door closed, the air lock opened, and the cart returned to the intermediate table area.

The removal of pigs was accomplished from the discharge end of the furnace. The operator worked an exit cart (same configuration as the unit in the decontamination shroud) using pushbutton controls. The operator started an automatic removal sequence that opened the furnace door and drove the cart into the furnace in the down position. Once in the furnace, the cart was raised lifting the decontaminated pigs off of the firebricks. The cart then left the furnace and stopped in an air lock outside the furnace until the furnace door closed. The door to the air lock was then opened and cart and pigs were brought to the outside (Figure 9). The cart was unloaded using a forklift and was returned to the air lock in a down position. After removal from the furnace, the pigs were verified decontaminated to a "5X" condition. They were then transported to the salvage yard for reissue in accordance with existing procedures.

### **1.2.3 DISPOSAL OF BOXED SETS**

#### **1.2.3.1 General**

Boxed sets (X302, X547, X550 and X551) were transported by truck to Bldg. 1611 in CNU-80 containers. See Figure 10 for a flow diagram of boxed set operations. The CNU-80's were moved from the trucks into the receiving room of Bldg. 1611 and placed on a supply conveyor. The supply conveyor extended through an airlock into the disassembly room. The containers were moved from the supply conveyor, by an electric/manual forklift, to the box feed chute area. The CNU-80 lid was removed once the container was in the disassembly room. These boxed sets required no disassembly. They were manually inserted into the deactivation furnace through the box feed chute assembly (See Figure 11).

#### **1.2.3.2 Equipment Description**

The Box Feed Chute assembly is a small airlock that isolates the deactivation furnace from the disassembly room. The chute is inclined at an angle of 51 degrees above horizontal. The upper (outer) door is manually opened and closed with a pneumatically operated cylinder providing a lock when the assembly has been sequenced. The flapper (lower) door is operated by a pneumatic cylinder to rotate upward 90 degrees, thereby allowing the ID Set box, within the airlock, to slide down into the deactivation furnace.

As soon as the box clears the flapper door, the cylinder closes the door and a two-minute purge begins. Purging air is induced into the airlock chamber at 5.0 PSIG and 690 SCFH. This provides the capability of 20 air charges during the two-minute purge cycle.

The controls are time-sequenced, so that a box set may be inserted into the deactivation furnace every five minutes.



**Figure 8 PIGS BEING DEPOSITED IN DECONTAMINATION FURNACE**

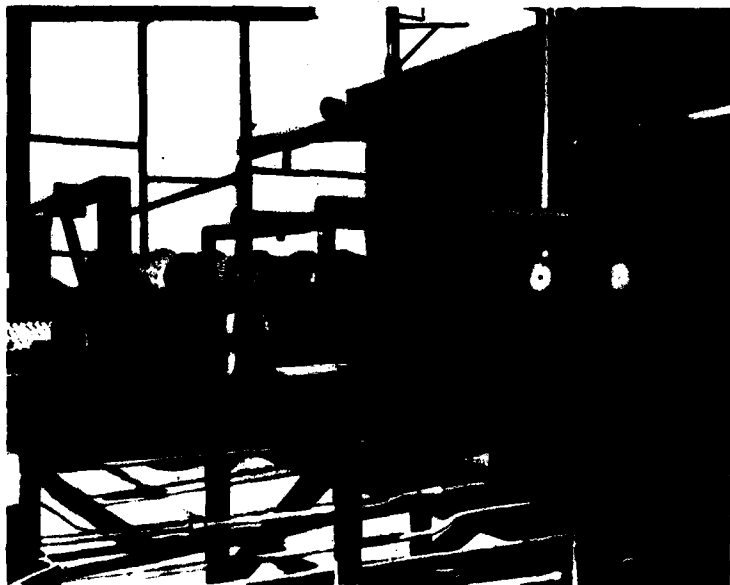

**Figure 9 PIGS AFTER DECONTAMINATION**

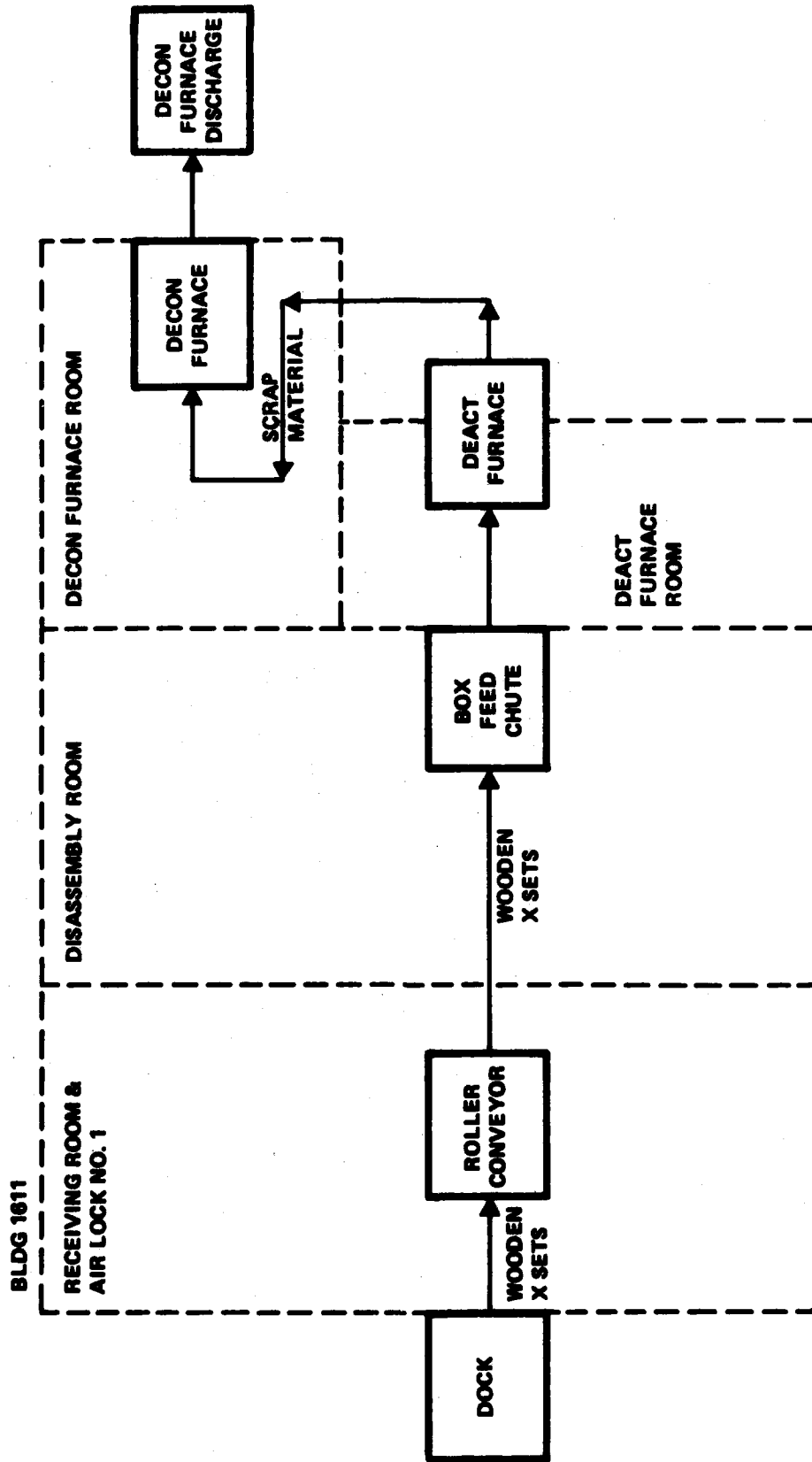

Figure 10 ID SETS PROCESS FLOW DIAGRAM - X SETS



Figure 11 BOX FEED CHUTE

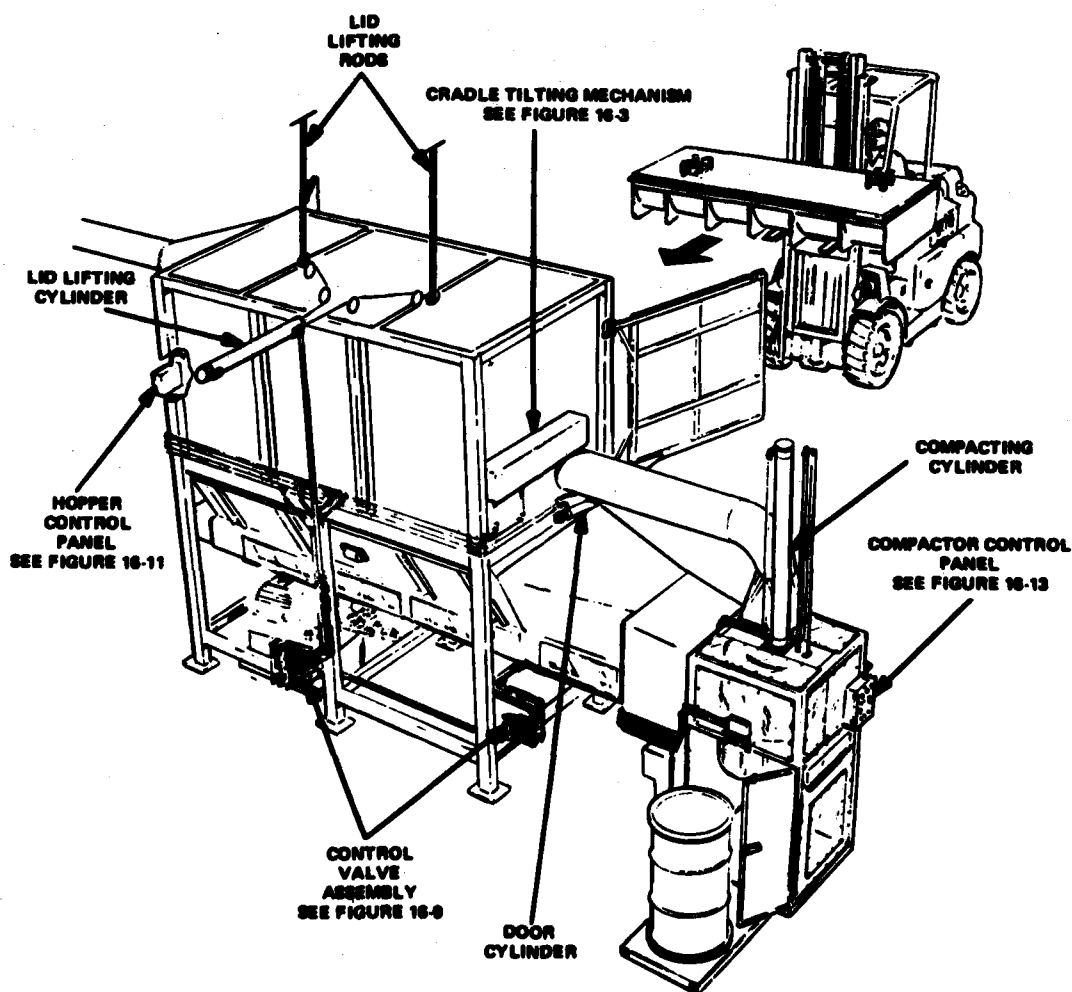

Figure 12 RESIDUE HANDLING EQUIPMENT

### **1.2.3.3 Process Description**

The box feed chute operator opened the upper door and inserted a box set. The door was closed and the PUSH TO CYCLE pushbutton was pressed. The flapper door opened and the boxed set slid into the deactivation furnace. The two-minute purge immediately started upon closing of the flapper door. A delay-loading timer also started and prevented cycling a set to the furnace for five minutes. At the end of five minutes, the BOX FEED CHUTE READY lamp lit and a new feed sequence could commence.

The residue from the deactivation furnace was conveyed to the decontamination furnace for further thermal treatment. A residue tray was inserted into the decontamination furnace to catch this residue and continue treatment. Periodically the tray was raked (from the rear of the furnace) to prevent residue buildup and spilling onto the floor of the decontamination furnace. When operations were completed, the tray was removed and the residue was packaged in 55 gallon drums.

### **1.3 WASTE DISPOSAL**

The waste residue from the CAIS disposal included the furnace trash, electrostatic precipitator (ESP) residue, and the dried salts from spray drying the brines and other liquid industrial wastes (see Figures 12, 13 and 14). The furnace trash, both deactivation and decontamination furnaces, was processed through the residue compactor and placed in 55 gallon drums. The ESP residue was placed in 55 gallon drums directly from the bins at the bottom of the ESP cells. The waste liquid was pumped to the spray dryer holding tanks in Bldg. 1703, dried to salts, and then placed in 55 gallon drums. All drums have been stored in warehouses awaiting determination of final disposition. Refer to Section 2, Paragraph 2.3, for a summary of the wastes generated during mustard operations.



**Figure 13 ELECTROSTATIC PRECIPITATOR**



**Figure 14 SPRAY DRYER**

## **CHAPTER 2. PRODUCTION SUMMARY**

### **2.1. SETS DESCRIPTION**

There are a total of seven types of Chemical Agent Identification Sets scheduled for disposal under this program. Mustard Operations, Phase I of the program, disposed completely of two of the seven types (K941 and K942, Toxic Gas Sets), and the sets containing mustard agent from a third type (X302, X547, X550, and X551, Gas Set Identification, Instruction (Navy)) (see Figure 15.).

#### **2.1.1 K941, TOXIC GAS SET**

These sets were contained in a steel cylinder (pig) 6½ inches (168.3mm) in diameter, approximately 38 inches (956.2mm) long, and a 0.145 inch (3.7mm) thick wall (see Figure 16). The open end was closed by a flanged end cover which was secured by eight bolts and sealed with a lead gasket between the body of the pig and the flange cover. There were six sealed metal containers (cans) packed in each cylinder. Each can contained four, 4 oz. bottles, and each bottle was placed in a layer of sawdust to preclude breakage. Each bottle contained 3½ oz. - 4 oz. (0.103 - 0.188 liter) of mustard agent (H) or distilled mustard (HD) for a total of 84 oz. - 96 oz. (2.433 - 2.839 liters) per cylinder.

#### **2.1.2. K942, TOXIC GAS SET**

These sets were originally packaged in steel drums (3.15 liters per drum), and were repacked in pigs prior to transportation. Two ampules, each 1½ inches (46.65 mm) in diameter and approximately 4½ inches (117.48 mm) long, containing 0.1125 liter of distilled mustard (HD, neat) agent, were packed in vermiculite or sawdust in a K951 type press-fit can. There were two ampules in each can and four cans in each cylinder for a total agent per cylinder of 0.9 liter. Total cylinder weight was 110 lbs.

#### **2.1.3 X SETS, GAS SET IDENTIFICATION, INSTRUCTIONAL (NAVY)**

These sets were packed in wooden boxes with hinged covers (see Figure 17). The boxes measured 7½ inches (191 mm) wide by 16 inches (406 mm) long by 11¼ inches (298 mm) high, and were divided into two compartments. Each compartment held a can 4¼ inches (110 mm) in diameter and 6¾ inches (175 mm) high, surrounded by packing material. Inside each can was a bottle with a ground glass top. Contents of the bottles for the mustard operations were as follows:

**X302** - One bottle with 1.7 fl. oz. (0.025 liter) nitrogen mustard (HN-1) and one bottle with 1.7 fl. oz. (0.025 liter) nitrogen mustard (HM-3). Both agents were absorbed on 3 fl. oz. (90 cc) of activated charcoal.

**X547** - Same as X302, except agent was mustard gas (H or HD) in both bottles.

**X550** - Same as X302, except agent was nitrogen mustard (HN-1) in both bottles.

**X551** - Same as X302, except agent was nitrogen mustard (HN-3) in both bottles.



**Figure 15 IDENTIFICATION AND TRAINING SETS**



**Figure 16 TOXIC GAS SET K941**



**Figure 17 GAS SET IDENTIFICATION,  
INSTRUCTIONAL, X-SETS**

## 2.2 NUMERICAL SUMMARY OF SETS DESTROYED

DATE	TYPE OF SET		X547	X550	X551
	K941/K942	X302			
5/8/81		17			
5/11/81		28			
5/12/81		34			
5/13/81		2	45		
5/14/81			45		
5/19/81			20		
5/20/81			45		
5/21/81			40		
5/22/81			45		
5/26/81	10				
5/27/81	14				
5/28/81			15		
5/29/81			60		
6/1/81			19		
6/4/81			12		
6/5/81			50		
6/8/81	7				
6/9/81	17				
6/11/81	16				
6/12/81			24		
6/17/81	20				
6/18/81			64		
6/19/81			71		
6/22/81	22				
6/23/81	22				
6/24/81	24				
6/25/81			53		
6/26/81			79		
6/29/81	22				
6/30/81	26				
7/1/81	19				
7/2/81			60		
7/6/81	18				
7/7/81	24				
7/8/81	18				
7/9/81			75		
7/10/81			60		
7/13/81			15		
7/14/81			75		
7/15/81			60		
7/16/81			60		
9/24/81			15		
9/25/81			60		
9/28/81			30	30	
9/29/81				60	
9/30/81				75	
10/1/81				75	

TYPE OF SET DATE	K941/K942	X302	X547	X550	X551
10/2/81				60	
10/5/81				45	
10/6/81				60	
10/7/81	11				
10/8/81	17		5		
10/9/81				60	
10/13/81	10				
10/14/81				60	
10/15/81				45	
10/19/81				45	
10/20/81				60	
10/21/81				21	
10/22/81				54	
10/23/81				60	
10/26/81				45	
10/27/81				52	
10/28/81				68	
10/29/81				75	
11/2/81	14				
11/3/81	19				
11/4/81	22				
11/5/81	7				
11/6/81				75	
11/9/81	17				
11/10/81	21				
11/12/81	20				
11/13/81				75	
11/16/81	11				
11/17/81	24				
11/18/81	25				
11/19/81	25				
11/20/81				72	
11/23/81	20				
12/7/81	19				
12/9/81	24				
12/10/81	26				
12/11/81	27				
12/14/81	24				
12/15/81	26				
12/16/81	28				
12/17/81	28				
12/18/81	14				
12/22/81					45
12/28/81					60
12/29/81					30
12/30/81					90
1/4/82					75
1/5/82	22				

TYPE OF SET DATE	K941/K942	X302	X547	X550	X551
1/6/82	22				
1/8/82					75
1/11/82					30
1/12/82					45
1/13/82					90
1/14/82					75
1/15/82					90
1/18/82					70
1/19/82					84
1/20/82					75
1/21/82					90
1/22/82					75
1/25/82					60
1/26/82		1		8	59
1/27/82				22	3
1/28/82					24
<b>TOTAL</b>	<b>802</b>	<b>82</b>	<b>1202</b>	<b>1302</b>	<b>1246</b>

### 2.3 NUMERICAL SUMMARY OF WASTE GENERATED

DATES	FURNACE RESIDUE DRUMS	SPRAY DRYER SALTS DRUMS	ESP RESIDUE DRUMS
5/11/81		3	
5/12/81	1	7	
5/14/81	1		
5/19/81	1	16	
5/20/81		1	
5/21/81	1	1	
5/22/81	1		
5/26/81	1		5
5/28/81		15	
5/29/81		5	
6/1/81	2		
6/8/81	4		
6/11/81	1	14	
6/12/81		11	
6/15/81	1	1	
6/16/81		14	
6/18/81	1		
6/19/81	1		
6/22/81	2		
6/23/81	2		
6/25/81	4		
6/26/81	1		
6/29/81			13
7/1/81	3	34	
7/6/81	4		
7/7/81	4		
7/8/81	2		
7/9/81	2		
7/10/81	2		
7/13/81	4	31	
7/14/81		15	
7/15/81	2		
7/16/81	1		
7/21/81			4
8/3/81		28	
8/5/81		20	
8/6/81		32	
8/7/81		32	
8/10/81		32	
8/11/81		8	
9/1/81	1		
9/3/81		6	
9/8/81		7	
9/25/81	2		
9/28/81	2		3
9/29/81	2		
9/30/81	2		
10/1/81	2		
10/2/81	2		

DATE	FURNACE RESIDUE DRUMS	SPRAY DRYER SALTS DRUMS	ESP RESIDUE DRUMS
10/5/81	3		
10/6/81	2	30	
10/7/81	3		
10/8/81	2		
10/9/81	2		
10/13/81	3		
10/14/81	1		
10/15/81	2		
10/16/81	2		
10/20/81	2		
10/22/81	2	45	
10/23/81	2		
10/26/81	2		
10/27/81		46	
10/28/81	3		
10/29/81	2	19	
10/30/81		27	
11/2/81	1		6
11/3/81	1		
11/4/81	1		
11/5/81	2		
11/6/81	1		
11/9/81	4		
11/10/81	2		
11/12/81	2		
11/13/81	2	14	
11/16/81	3	7	
11/17/81	2		
11/18/81	3		
11/19/81	2		
11/20/81	2		
11/23/81	2		
12/7/81	2		
12/9/81	2		
12/11/81	4		
12/14/81	2		
12/15/81	2		
12/16/81	2		
12/22/81	2		
12/23/81			4
1/5/82	7		
1/11/82	7		
1/14/81	5		
1/19/82	4		
1/25/82	6		
1/26/82	4	1	
1/27/82		1	
TOTAL	<hr/> 174	<hr/> 523	<hr/> 35

## 2.4 SYNOPSIS OF MAJOR DOWNTIME

### 2.4.1 GENERAL

In the interpretation of downtime data, three methods are widely used. These are the "frequency of occurrence," "subsystem downtime," and "process downtime" methods. Each method has inherent advantages and disadvantages.

The most familiar, and most widely used by management, is the "process downtime" method which measures the overall time the plant is not processing. This method fails to identify problems specifically enough for engineering purposes.

Another method, used by maintenance at RMA, is the "frequency of occurrence" method, which is a good "rule-of-thumb" for how a given subsystem is performing. For historical purposes, however, it fails to indicate the extent of an event.

In this report the "subsystem downtime" method is used. This method is very specific and historically accurate. Its main disadvantage is that of being open to misinterpretation by management oriented personnel who must be cautioned that because a certain subsystem is down, it does not mean the overall process is down. One can *not* total hours and arrive at the hours the process was down by this method.

### 2.4.2 SUBSYSTEM DOWNTIME

DATE	SUB-SYSTEM	PRIMARY COMPONENT	DOWN TIME HRS	COMMENTS
5/12/81	Enviro. Monitor	Alarm	1.5	
5/13/81	Decon. Furnace	Burner	2.0	
5/14/81	Decon. Furnace	Burner	8.0	
5/15/81	Decon. Furnace	Burner	8.0	
5/18/81	Decon. Module	Battery	8.0	Battery charger failed
5/19/81	Decon. Module	Ski	2.83	Battery charger failed
5/20/81	Decon. Furnace	Burner	6.05	Replaced burner
5/26/81	Decon. Furnace	Burner	8.0	Flow control valve failed
5/28/81	Set movement	Box set	5.0	Delay due to CAIC exercise
6/2/81	Deact Furnace	Conveyor	8.0	
6/3/81	Deact Furnace	Conveyor	8.0	
6/4/81	Set movement	Box set	3.0	
	Enviro Monitor	Other	2.0	No lab coverage
6/8/81	Set movement	Pig Set	3.5	
6/9/81	Decon Furnace	Burner	1.93	Burner #3 defective
	Glovebox	Pig set	6.5	Bolts from 7 pigs could not be removed; 1 K941 pig contained K 951 cans; manual can opener slow.
6/10/81	Administration	Other	8.0	CAIS exercise
6/12/81	Scrubbers	Fan	8.0	Scrubber fan repair
6/15/81	Scrubbers	Fan	8.0	Scrubber fan repair
6/16/81	Scrubbers	Fan	8.0	Scrubber fan repair
6/22/81	Decon furnace	Conveyor	1.95	Replaced limit switch
6/23/81	Decon furnace	Inside cart	3.97	

6/24/81	Decon furnace	Inside cart	5.98	
6/29/81	Decon furnace	Pilot	8.0	
6/30/81	Electro. Precip.	Other	1.75	Burned out cell resistor
7/1/81	Decon Module	Bridge	8.0	Cart emergency caused bridge track jam
7/8/81	Administrative	Other	1.75	Lab not in control
7/13/81	Deact furnace	Solenoid valve	5.67	
7/16/81	HVAC	AHU-2	8.0	
9/24/81	Box feed chute	Actuator feeler	1.0	Flapper repaired in-place
10/13/81	Decon furnace	Pilot	3.25	Fuel-air mixture adjustment
	Residue handling	Conveyor	4.73	Failures due to switch adjustment
10/15/81	Afterburner	Burner	7.02	Oil-air regulator malfunction
10/16/81	Residue handling	Conveyor	8.0	Repaired conveyor head shaft
10/19/81	Decon furnace	Conveyor	2.0	Final adjustment
10/20/81	Enviro Monitor	Bubbler filter	2.62	SF <sub>6</sub> recirculating from stack
10/21/81	Decon module	Switch	2.05	Damper adjustment
10/22/81	Administrative	Other	2.00	Dead battery in ambulance
10/26/81	Glovebox	Door	1.32	Glovebox door unlatched
10/27/81	Set movement	Other	2.5	Convoy arrived late
10/30/81	Scubbers	Other	7.0	Acid washing
11/4/81	Glovebox	Pigset	1.0	Set misidentified
11/5/81	Glovebox	Pigset	4.8	Jackscrew malfunction
11/9/81	Decon furnace	Fireye	1.35	Dirty lens
11/12/81	Enviro Monitor	Bubbler-filter	1.22	Bubbler tests not completed
11/16/81	Administrative	Other	2.25	Admin. delay
11/23/81	Deact furnace	Conveyor	8.0	Discharge conveyor jammed
12/8/81	Quench	Spraytree	8.0	Water leak into decon furnace room
12/11/81	Decon furnace	Burner	3.0	Flame detector failure
12/21/81	Administrative	Other	1.5	Admin. procedures
	Control room	Fuse	4.8	Loose fuse in processor
12/22/81	Decon furnace	Controller	2.5	UV scanner malfunction
12/23/81	Decon furnace	Controller	8.0	UV scanner ground fault
12/24/81	Decon furnace	Controller	4.0	Fireye system malfunction
	Administrative	Other	4.0	Admin procedures
12/29/81	Residue handling	Tray	2.0	Forklift malfunction
	Control room	Controller	3.5	Processor malfunction
12/31/81	Decon furnace	Burner	8.0	Boxset cans blocked burner port
1/4/82	Enviro Monitor	Bubbler-Filter	1.58	Late bubbler test delayed start
1/6/82	Decon furnace	Burner	1.8	Burner dirty
	Decon furnace	Switch	4.9	Cart limit switch failure
1/7/82	Decon furnace	Burner	3.5	Controller malfunction
1/11/82	Scrubbers	Controller	2.42	Press. & flow gages reset
	Quench	Tank	3.0	Ice in tank
	Scrubbers	Fan	3.0	Ice in damper control

DATE	SUB-SYSTEM	PRIMARY COMPONENT	DOWN TIME HRS	COMMENTS
1/12/82	Scrubbers	Stack	5.83	West scrubber iced up
	Decon furnace	Fireye	1.33	Decon fireye cable shorted
1/14/82	Decon Module	Outside cart	1.75	Cart manually removed from furnace
1/20/82	Box feed chute	Hopper	1.08	Jammed
1/25/82	Afterburner	Fireye	2.33	Dirty lens
	Decon furnace	Controller	3.28	
1/26/82	Decon furnace	Switch	2.57	Draft damper malfunction
1/27/82	Decon furnace	Inside cart	8.0	Cart rails replaced
1/28/82	Residue handling	Hopper	8.0	Hopper conveyor failure

### 2.4.3 PROCESS DOWNTIME

A process downtime analysis is provided in Paragraph 5.2.4 of the Conclusion Section. A process downtime of 38% was calculated which, allowing for startup problems, is not unexpected. The ID Sets project was originally scheduled with a 30% downtime factor and the average downtime is expected to approach this figure by the end of the project. Project schedule status is currently satisfactory on an overall basis.

## CHAPTER 3 AIR MONITORING SUMMARY

### 3.1 DESCRIPTION OF SAMPLING TECHNIQUES

#### 3.1.1 MUSTARD AGENT SAMPLING

Sampling for mustard was accomplished by drawing air from the areas to be sampled through a container filled with a liquid. The liquid of choice, diethylphthalate, had a particular affinity to mustard and collected it with essentially 100% efficiency. The air passed through the solution in the container obviously bubbled, lending the name to this sampling apparatus - the bubbler (see Figure 18).

The bubbler tubes used for mustard were made of glass and were filled with glass beads to maintain high collection efficiency. Air samples were drawn through these bubblers at a rate of 6 liters per minute. The flow was maintained by the use of in-line critical orifices. The standard fill for a mustard bubbler was 10 ml. of diethylphthalate. The bubblers were marked with a ring of brown tape to color-code identify them as mustard bubblers. In addition, at each sampling location was a constant temperature bath in which the bubblers were immersed. The temperature was set at 2 to 8°C and monitored during the two hour sampling period.

Each day, the bubblers were inspected, cleaned, and filled at the laboratory (Bldg. 313) and then transported to the CAIS disposal plant (Bldg. 1611). Monitoring station personnel obtained the bubblers from the plant chemist's office and installed them at four locations: the disassembly room (DR), control room (CR), residue area (RA), and the stack (ST) (see Figure 19).

Bubblers were replaced sequentially after a two-hour sampling period at all locations. In addition, a staggered shift of two hour bubblers were started every hour in the disassembly room. Bubblers in the disassembly room therefore typically ran 0800-1000, 0900-1100, 1000-1200, etc. Upon completion of a sampling term, each bubbler was retrieved, returned to the plant chemist's office, and packed for transportation to the laboratory. They were then taken to the laboratory for analysis. All bubblers, when in transit were packed in ice.

#### 3.1.2 SF<sub>6</sub> TRACER GAS SAMPLING

Sulfur hexafluoride (SF<sub>6</sub>) gas was metered into the disassembly glovebox and box feed chute at a pressure of 35 psi to act as a tracer gas. SF<sub>6</sub> is non-toxic, chemically inert, odorless, tasteless, and can be detected at very low concentrations (10<sup>-12</sup> parts of SF<sub>6</sub> per part of air). Samples of disassembly room and control room air were drawn, automatically by the detector (see Figures 20 & 21), every five minutes. The detector was set to sense buildups of SF<sub>6</sub> outside of the glovebox or box feed chute of 10 parts per trillion to indicate potential leakage.

#### 3.1.3 NO<sub>x</sub> and SO<sub>2</sub> Sampling

The Dynascience monitor sampled Bldg. 1611 exhaust stack gas on a continuous basis (see Figure 22). The stack gas was drawn through a 100 micron Cuno stainless steel filter by a sampler pump. The gas was cooled by a water bath, analyzed, and then returned to the stack. Calibration was maintained by periodically sampling known concentrations of NO<sub>x</sub> and SO<sub>2</sub>.

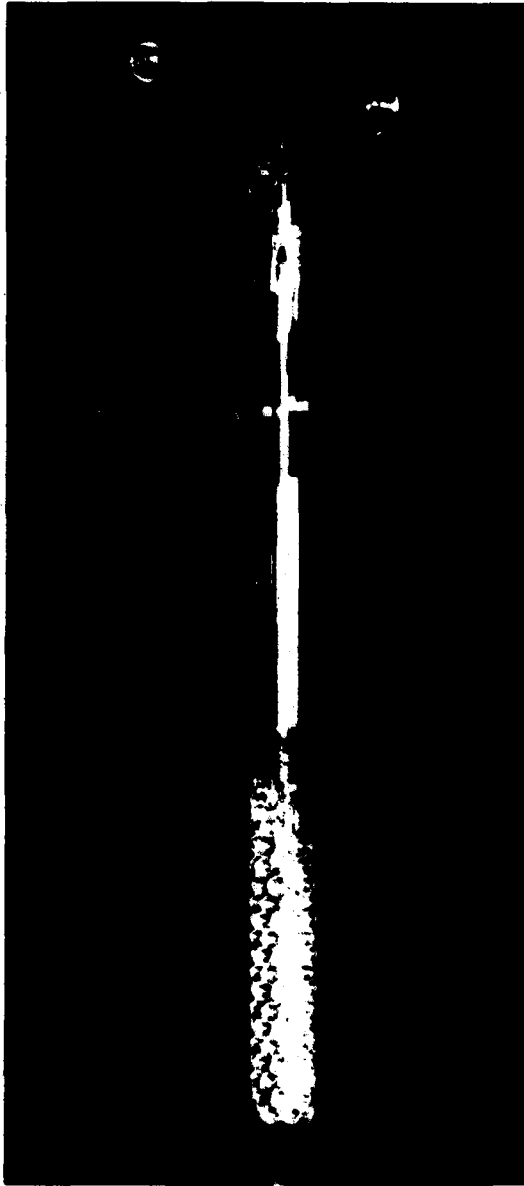

A-982,137

**Figure 18**  
**TYPICAL MUSTARD BUBBLER**



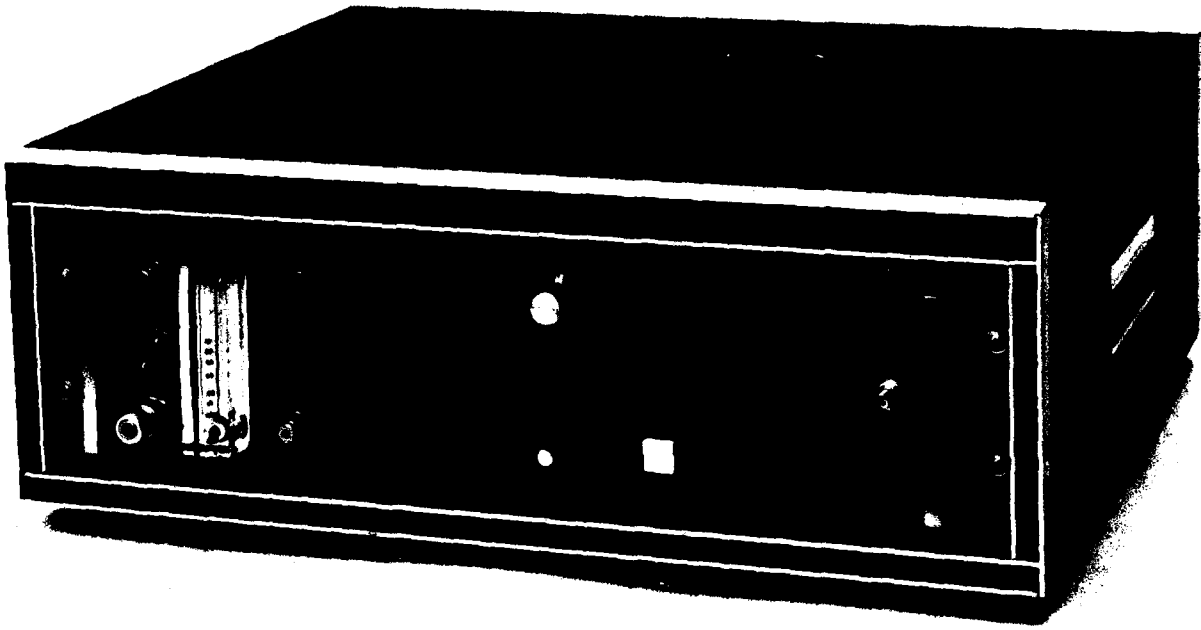

Figure 20 SF<sub>6</sub> DETECTOR/ANALYZER

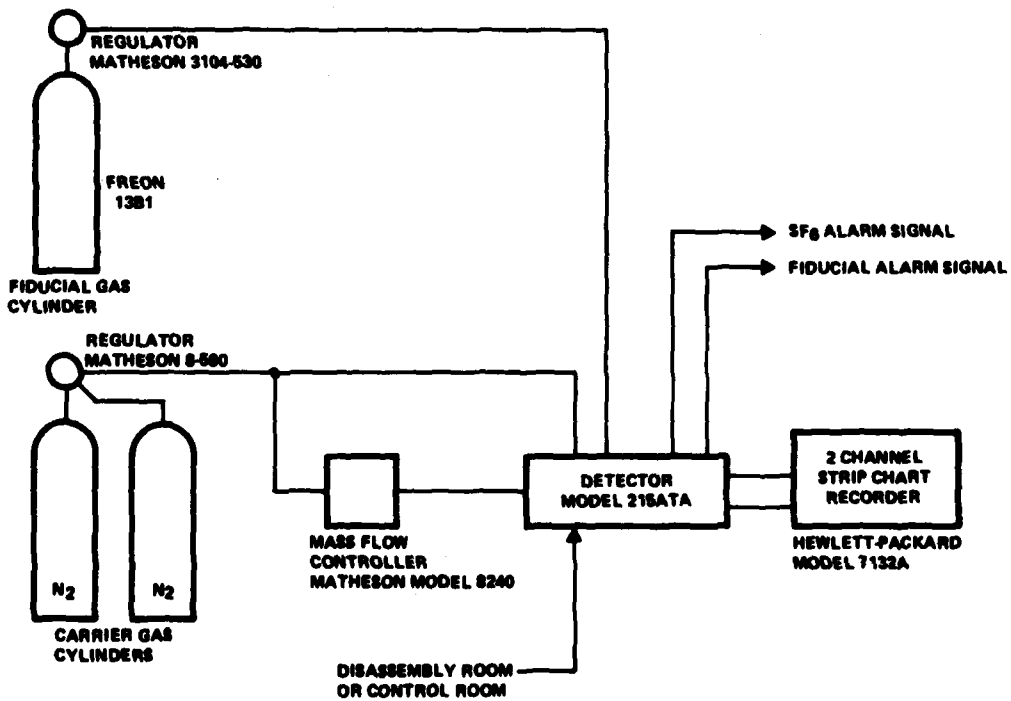

Figure 21 SF<sub>6</sub> FLOW DIAGRAM

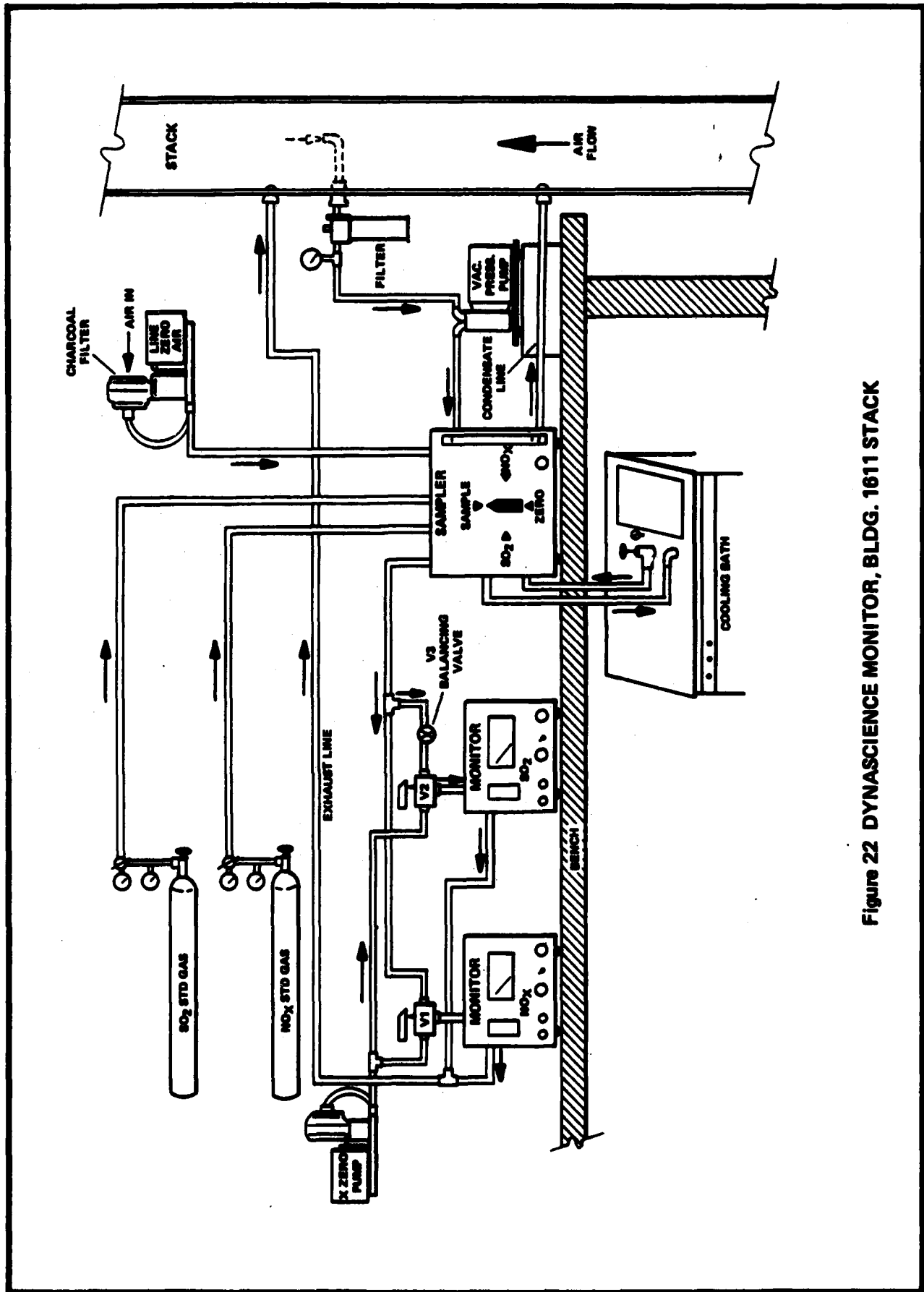

Figure 22 DYNASCIENCE MONITOR, BLDG. 1611 STACK

## 3.2 DESCRIPTION OF ANALYSIS TECHNIQUES

### 3.2.1 MUSTARD AGENT ANALYSIS

#### 3.2.1.1 Analysis of Calibration Standards

The analysis for mustard was colorimetric. The instrument used was a Technicon Autoanalyzer. To initiate the analysis of standards, a 1.21  $\mu\text{g}/\text{ml}$  standard solution was prepared. One aliquot of this solution was placed into the auto-analyzer. The STANDARD CAL control was used to adjust the recorder to a peak height of 80 chart units. This first standard was checked after a 30-minute warm-up period.

Following this initial procedure, duplicate aliquots of three calibration standards (0.0, 0.24, and 1.21  $\mu\text{g}/\text{ml}$ ) were placed on the auto-sampler tray followed by a single aliquot of each of the blank standards. Approximately six minutes after each standard was sampled, the peak appeared on the recorder. The analyst recorded these results on an Analyst Work Sheet designated for calibration.

A standards curve (see Figure 26) was prepared by linear least squares regression of peak height vs. concentration. The acceptable limits for slope were  $66 \pm 5$  units/ $\mu\text{g}/\text{ml}$  and the coefficient of variance (determination of R-squared) could not be below 0.995.

The analyst was required to compare his results at the three standards to the following criteria:

Concentration	Max Peak Height	Min Peak Height
0.00 $\mu\text{g}/\text{ml}$ (2 ea)	0.5 chart units	-1.25 chart units
0.24 $\mu\text{g}/\text{ml}$ (2 ea)	17.25 chart units	13.25 chart units
1.21 $\mu\text{g}/\text{ml}$ (2 ea)	83.00 chart units	77.25 chart units

If the analytical results did not meet all of the above criteria, the operator was required to recalibrate his instrument. If the results were satisfactory the operator was allowed to begin the analysis of actual plant samples.

#### 3.2.1.2 Analysis of Actual Plant Samples and Quality Control Samples

The liquid level in each glass bubbler was checked and changes recorded. If the level was low, the bubbler was brought to the mark by adding DEP. The solution was transferred to test tubes and any water present was removed.

Aliquots were taken from each test tube and transferred to sample cups, which were then placed on the auto-sampler tray. Known Standards were placed as "markers" before and after the unknowns, and periodically among the unknown samples as quality control samples. As with standards analysis, approximately 30 minutes were initially required before results appeared on the recorder. Results were attained every six minutes following the initial reading.

#### 3.2.1.3 Final Analysis of Calibration Standards

At the completion of analysis of actual plant samples, the analyst was required to again run the three calibration standards (0.00, 0.24, 1.21  $\mu\text{g}/\text{ml}$ ) and assure that they met the criteria stated in Paragraph 3.2.1.1. In addition, these results were also

analyzed by computer as described in Paragraph 4.1.1. If the analyst's results did not meet the standardized criteria, he was required to recalibrate his instrument and reanalyze the actual plant samples.

### 3.2.2 SF<sub>6</sub> TRACER GAS ANALYSIS

SF<sub>6</sub> tracer gas analysis was accomplished at ambient temperature, using an electron-capture detector in series with a gas chromatograph column, a sampling valve, and an N<sub>2</sub> carrier gas (see Figure 21). Two detectors were used: one each for the control room and the disassembly room. Sampling was done by drawing air from these rooms into the sampling valve by means of an internal pump. A fixed internal sample volume determined the quantity of the sampled air to be analyzed.

An electron-capture gas chromatograph used the high electron affinity of gases with halogen group elements to provide a measurable signal. A sample was separated into component gases by means of a gas chromatographic column. In the case of SF<sub>6</sub> detection, this column was made of finely ground molecular sieve.

In the detector module, a tritium foil source, provided a stream of beta particles which ionized the dry nitrogen carrier gas and developed a secondary electron flow, termed the standing current. An electronegative gas captured electrons from this ionized gas stream in proportion to the concentration of the gas present in the sample. The detector collected these electrons, and an electrometer measured the current. The presence of an electronegative gas flowing through the detector decreased the standing current (by absorbing electrons) in proportion to the concentration of the electronegative gas. The electrometer operational-amplifier detected the change in current, and provided an output voltage proportional to the concentration of the gas. Through the use of a reference calibration chart, the read-out was directly readable as parts per trillion of SF<sub>6</sub>.

### 3.2.3 NO<sub>x</sub> and SO<sub>2</sub> ANALYSIS

The dynascience monitor used a unique electro-chemical transducer. The transducer was a sealed electrolytic device, in which the direct electro-oxidation of absorbed gas molecules at a sensing electrode, resulted in a current directly proportional to the particle pressure of the pollutant gas. In operation, the gas diffused through the membrane and the thin film electrolyte layer, where it was directly proportional to its concentration of the gas being monitored.

## 3.3 SUMMARY OF REGULATORY STANDARDS MAINTAINED

### Work Area Mustard Standard

.003 mg/m<sup>3</sup> [.216 µg/ml] (Action level .0025 mg/m<sup>3</sup> [.18 µg/ml])

### Stack Mustard Standard

.03 mg/m<sup>3</sup> (Action level .015 mg/m<sup>3</sup>)

### SF<sub>6</sub> Alarm Level

12 ppt

### **3.4 SUMMARY OF AIR MONITORING READINGS BY DAY**

The accompanying two tables are a summary of monitor readings from 8 May 1981 through 26 January 1982 for the various work areas (Table 4) and for the plant exhaust stack (Table 5). Both tables indicate a minimum of incidents, wherein the readings exceeded the established standards. As discussed in Chapter 5, diesel fuel oil adversely affects the ability of the monitors to differentiate it from mustard agent. When there were no malfunctions in the fuel oil delivery system there were no monitor readings that exceeded the standards.

Three ID Set facility improvements have been undertaken to correct these misreadings. They consist of:

1. Installation of a small blower in the fuel oil pump house to dissipate the fumes, from the pumping operation, to the field north of Bldg. 1611.
2. Sealing any small leaks in the fuel oil delivery system.
3. Replacement of a defective burner assembly on the decontamination furnace.

TABLE 4

8 MAY 81 - 28 JAN 82  
28 READINGS/1985 SAMPLES

DATE	LOCATION	TIME	READING mg/m <sup>3</sup>	RANGE mg/m <sup>3</sup>	SET
7 JUL 81	DR	1000-1200	.001	.001 - .001	K941
7 JUL 81	DR	1100-1300	.002	.002 - .002	K941
CAUSE: DR PROCEDURES VIOLATED — PIG OPENED IMPROPERLY IN ROOM.					
2 NOV 81	CR	0800-1000	.001	.001 - .002	K941
2 NOV 81	RA	0800-1000	.001	.001 - .001	K941
2 NOV 81	DR	1000-1200	.001	.000 - .001	K941
11 DEC 81	DR	1200-1400	.001	.001 - .001	K941
28 DEC 81	RA	1000-1200	.001	.001 - .001	X-551
28 DEC 81	RA	1400-1600	.005	.004 - .005	X-551
CAUSE: GC CONFIRMATION OF .005 READINGS SHOWS IT WAS NOT MUSTARD. FORKLIFTS WERE PULLED INTO AREA OUT OF SNOW STORM, DRY GAS PUT IN TANKS AND ENGINES RUN — AREA "FILLED WITH SMOKE."					
29 DEC 81	RA	0800-1000	.001	.001 - .001	X551
29 DEC 81	CR	1000-1200	.001	.000 - .001	X551
29 DEC 81	RA	1000-1200	.001	.000 - .001	X551
30 DEC 81	DR	0900-1100	.001	.001 - .001	X551
6 JAN 82	RA	0800-1000	.001	.000 - .001	K941
11 JAN 82	CR	0800-1000	.001	.000 - .001	X551
11 JAN 82	RA	0800-1000	.001	.001 - .001	X551
11 JAN 82	CR	1000-1200	.001	.000 - .001	X551
11 JAN 82	RA	1000-1200	.001	.001 - .001	X551
11 JAN 82	CR	1200-1400	.001	.001 - .001	X551
11 JAN 82	CR	1400-1600	.001	.000 - .001	X551
11 JAN 82	RA	1400-1600	.001	.001 - .001	X551
13 JAN 82	RA	0800-1000	.001	.001 - .002	X551
13 JAN 82	CR	0800-1000	.001	.000 - .001	X551
13 JAN 82	RA	1400-1600	.001	.000 - .001	X551
13 JAN 82	RA	1500-1700	.001	.000 - .001	X551
14 JAN 82	RA	1000-1200	.001	.001 - .001	X551
14 JAN 82	CR	1000-1200	.001	.001 - .001	X551
26 JAN 82	RA	1400-1600	.001	.001 - .001	X551
26 JAN 82	RA	1515-1715	.001	.000 - .001	X551

**TABLE 5**  
**STACK READINGS**  
**8 MAY 81 - 28 JAN 82**  
**50 READINGS/500 SAMPLES**

DATE	LOCATION	TIME	READING mg/m <sup>3</sup>	SET
8 MAY 81	ST	0800-1000	.001	X302
13 MAY 81	ST	1000-1200	.002	X547
13 MAY 81	ST	1200-1400	.002	X547
14 MAY 81	ST	0800-1000	.004	X547
14 MAY 81	ST	1000-1200	.009	X547
14 MAY 81	ST	1200-1400	.001	X547
20 MAY 81	ST	0800-1000	.001	X547
20 MAY 81	ST	1000-1200	.001	X547
22 MAY 81	ST	0800-1000	.001	X547
22 MAY 81	ST	1000-1200	.002	X547
26 MAY 81	ST	1400-1600	.020	K941
26 MAY 81	ST	1515-1715	.042	K941
<b>CAUSE: PROCESSED K941 SETS IMPROPERLY IN DEACTIVATION FURNACE</b>				
27 MAY 81	ST	1000-1200	.001	K941
28 MAY 81	ST	0800-1000	.001	X547
9 JUN 81	ST	1000-1200	.001	K941
18 JUN 81	ST	1000-1200	.002	X547
18 JUN 81	ST	1200-1400	.003	X547
18 JUN 81	ST	1400-1600	.001	X547
19 JUN 81	ST	0800-1000	.001	X547
19 JUN 81	ST	1000-1200	.002	X547
19 JUN 81	ST	1200-1400	.002	X547
19 JUN 81	ST	1400-1600	.001	X547
29 JUN 81	ST	1530-1730	.002	K941
13 JUL 81	ST	1400-1600	.001	K941
14 JUL 81	ST	1400-1600	.001	X547
15 JUL 81	ST	1000-1200	.002	X547
24 SEP 81	ST	0800-1000	.001	X547
13 OCT 81	ST	1200-1400	.001	K941
3 NOV 81	ST	1200-1400	.016	K941
<b>CAUSE: AFTERBURNER FLAMEOUT</b>				

DATE	LOCATION	TIME	READING mg/m <sup>3</sup>	SET
20 NOV 81	ST	0800-1000	.001	X550
14 DEC 81	ST	1000-1200	.003	K941
16 DEC 81	ST	0800-1000	.001	K941
22 DEC 81	ST	0800-1000	.002	X551
22 DEC 81	ST	1000-1200	.001	X551
28 DEC 81	ST	0800-1000	.001	X551
29 DEC 81	ST	1000-1200	.001	X551
30 DEC 81	ST	1400-1600	.001	X551
30 DEC 81	ST	1600-1800	.004	X551
<b>CAUSE: DECONTAMINATION FURNACE BURNER MALFUNCTION. FUEL OIL INTERFERENCE NOT MUSTARD.</b>				
4 JAN 82	ST	0800-1000	.009	X551
4 JAN 82	ST	1000-1200	.001	X551
4 JAN 82	ST	1200-1400	.004	X551
4 JAN 82	ST	1400-1600	.005	X551
<b>CAUSE: DECONTAMINATION FURNACE BURNER MALFUNCTION. FUEL OIL INTERFERENCE NOT MUSTARD.</b>				
5 JAN 82	ST	0800-1000	.009	K941
5 JAN 82	ST	1000-1200	.010	K941
5 JAN 82	ST	1200-1400	.006	K941
5 JAN 82	ST	1400-1600	.010	K941
<b>CAUSE: DECONTAMINATION FURNACE BURNER MALFUNCTION. FUEL OIL INTERFERENCE. NOT MUSTARD.</b>				
6 JAN 82	ST	0800-1000	.001	K942
8 JAN 82	ST	0800-1000	.001	X551
11 JAN 82	ST	0800-1000	.004	X551
11 JAN 82	ST	1000-1200	.001	X551

## **CHAPTER 4 DATA COLLECTION AND QUALITY CONTROL**

### **4.1 METHOD OF DATA COLLECTION**

For the Mustard Operations (Phase 1) of the CAIS disposal program, there were four generic categories for which data was collected, processed, and stored. These categories were: calibration, air monitoring, inventory control, and plant downtime. See Figure 23 for an illustrated diagram of data collection.

#### **4.1.1 CALIBRATION**

To establish daily calibration curves, known agent concentrations of 0.00, 0.24, and 1.21  $\mu\text{g}/\text{ml}$  were measured by each man/instrument combination each day (see Figure 24). For each man/instrument combination, one calibration run (0.00, 0.24, 1.21  $\mu\text{g}/\text{ml}$ ) was done before actual sample analysis to establish control, and a second was done at the completion of the actual data analysis, to demonstrate continued control. The data from all calibration runs was pooled and the multiple measurements of each concentration were used to establish confidence intervals around the complete regression line. The results of these measurements were taken to the data processing group each evening. The data was visually scanned for obvious errors and then entered onto magnetic cassette tape. The Tektronix min-computer (see Figure 25) then produced the daily calibration reports.

#### **4.1.2 AIR MONITORING**

For Phase I operations, air monitoring data was taken from the Analyst and Lab Data Coordinator Worksheets for mustard agent. Collected data was processed through the use of two Tektronix programs: Data Entry and Data Print. The purpose of the data entry program was to place the information, from the handwritten data sheets, onto magnetic cassette tape. The data print program was used to "parrot" the input data for checking and verification that the data was entered correctly.

After entering any corrections, the air monitoring statistical program was run. This statistical program used data previously recorded on tape as input, and generated the reports required by CAIS management to verify reliability of laboratory analysis.

#### **4.1.3 INVENTORY CONTROL**

Inventory data was collected, processed, and stored for the following six items:

- a. Receipt Inspection of CAIS at Bldg. 1611.
- b. Process Data on Furnace Residue (Pigs).
- c. Process Data on Furnace Residue (Drums).
- d. Process Data on Spray Dryer (Drums).
- e. Process Data on Electrostatic Precipitator (Drums).
- f. Process Data on Disassembly Room (Exception Report).

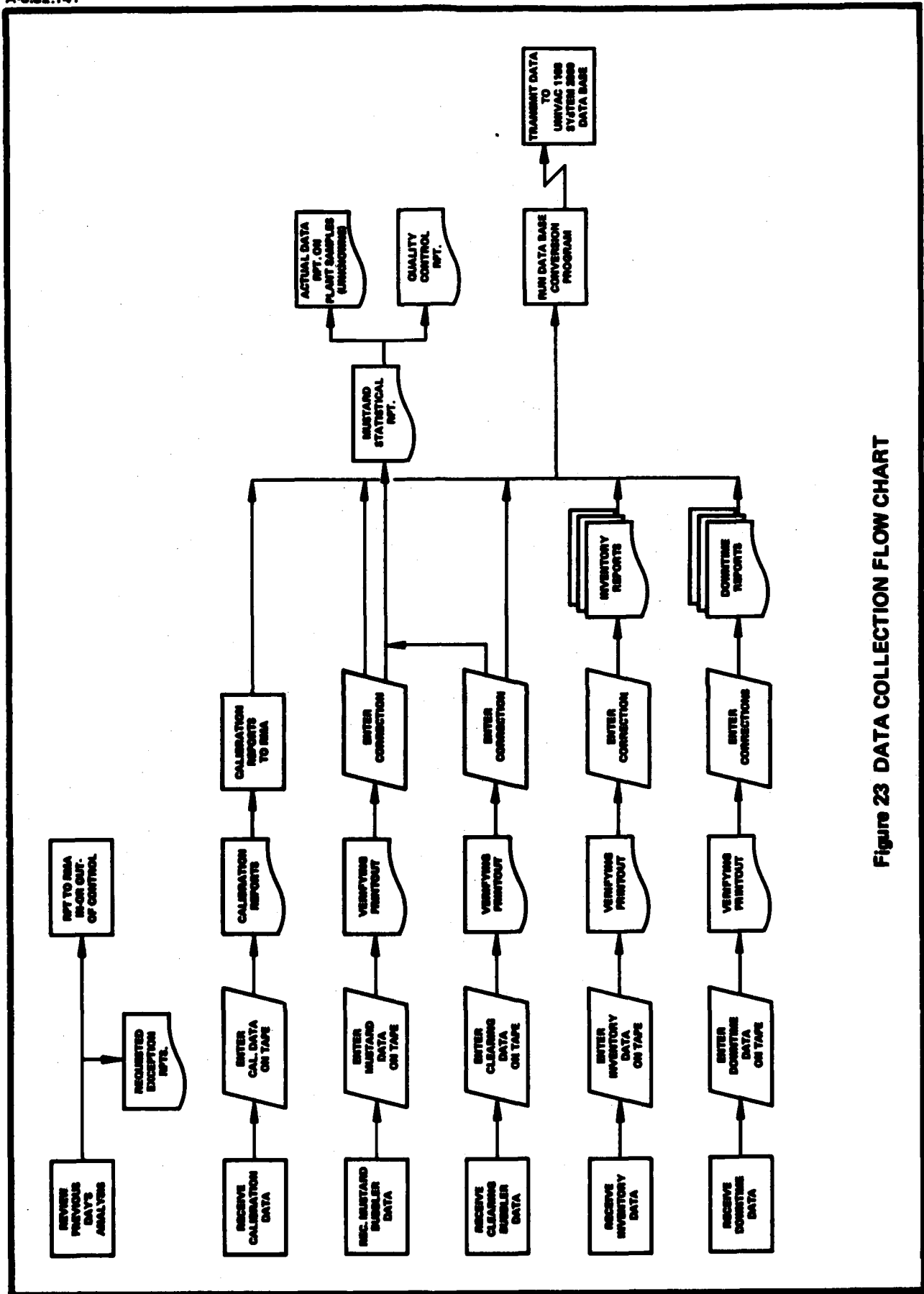
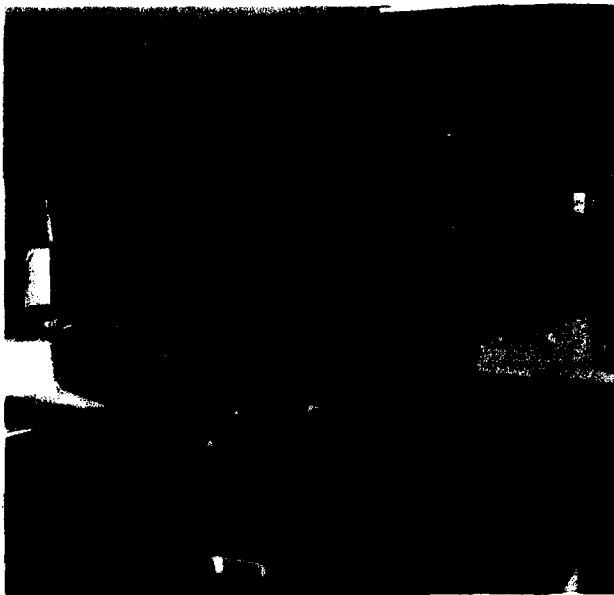

Figure 23 DATA COLLECTION FLOW CHART



**Figure 24 LABORATORY EQUIPMENT**



**Figure 25 DATA PROCESSING EQUIPMENT**

The data entry and data print programs were used in the same manner as for air monitoring (refer to Paragraphs 4.1.1). The data stored on the tape was manipulated by a program to produce desired inventory summary reports of various formats.

#### **4.1.4 DOWNTIME**

Building 1611 downtime was recorded on a data sheet and then entered, verified, and reported in the same manner as other data entry-data print programs. A daily report was required, even if it only stated "NO DOWNTIME." Various summary reports (normally monthly) were produced.

#### **4.1.5 DATA CONVERSION AND PERMANENT STORAGE**

At the end of each operating day, data was placed on a condensed or "merged" tape which was then sent to USATHAMA on a weekly basis. Inventory data was condensed from multiple files into a single file in this operation. At USATHAMA the processed data for each day was converted to a format that was acceptable to the Univac 1108 System 2000 data base.

To create a merged data tape, the computer operator inserted the program tape, the current day's data entry tape, and a blank tape in the Tektronix. The program tape obtained data from the data entry tape, converted it to Univac 1108 format, and entered the newly formatted data on the blank "merged" tape. The new "merged" tape was then sent to USATHAMA and used there to transmit the "merged" data to the Univac 1108. The Univac 1108 automatically scanned the data to assure that the format was acceptable.

At the conclusion of the transmission, the operator required the Univac 1108 to "playback" the transmitted data in order to confirm that the original transmission was correct and accurate.

### **4.2 DESCRIPTION OF AIR MONITORING DATA ANALYSIS**

#### **4.2.1 GENERAL**

The purpose of the air monitoring statistical program was to determine the relationship between a known concentration of mustard agent and an instrument/man response (measurement). The three main components of this program are: calibration, wherein each man/machine combination relationship established a daily curve; actual data analysis, wherein the accuracy and confidence limits of measurements taken in the CAIS disposal plant were established; and quality control charting, which determined accuracy and the precision of lab measurements. The statistical program drew its source data from the air monitoring data tape for the day under consideration.

#### **4.2.2 PROGRAM OPERATION**

In the early production runs, calibration curves for mustard were established at concentrations of 0.04, 0.24, 0.61, 0.97 and 1.21  $\mu\text{g}/\text{ml}$  for each man/instrument combination each day. In later operations, this was reduced to known concentrations

of 0.00, 0.24 and 1.21  $\mu\text{g}/\text{ml}$  were measured by each man/instrument combination each day. Two measurements of each concentration were used to establish confidence intervals around the complete regression line.

The statistical program drew upon the mustard air monitoring data tape, extracting the calibration data for the day. Using the peak heights obtained for each known concentration, the computer constructed a plot of known concentrations (X-axis) vs. peak height/instrument response (y-axis). The computer provided this plot (see Figure 26) as a report, along with the following information:

- a. Standard Army agent code for mustard.
- b. Date
- c. Bartlett's - a probability for the Bartlett's test, indicating the tendency of this small data set to be either homogeneous (a probability greater than 0.05) or non-homogeneous (a probability less than 0.05).
- d. R-squared - a statistical evaluation of how well the computer-selected equation fits the data. An R-squared value of 0.995 or greater was acceptable.
- e. MSE - mean square error - a statistical evaluation of the "distance" that the points fell from the selected regression line. No set criteria was used.
- f. (a) - the intercept of the regression line with the Y-axis.
- g. (b) - the slope of the selected regression line.
- h. (f), (g) and (h) - correction factors for data that might fit non-linear or special cases.

Using information from the calibration curve, the peak height readings from the actual data sheets were factored to establish a "true" value with corresponding upper and lower limits of accuracy. The actual measurements were revised to take into account the measurement errors determined by the calibration report. The upper and lower limits of accuracy were determined by the computer, which used a previously entered data base. The data base was kept in the statistical program. A report was then produced (see Figure 27) which displayed the following information:

- a. Actual data for Mustard agent.
- b. Date
- c. Sample - control number corresponding to the data entry print routines.
- d. Location - location of the ID Sets where the sample was collected.
- e. True - the value calculated by the computer, based on the previously constructed calibration curve (in  $\text{mg}/\text{m}^3$ ).
- f. Lower 95% - the value calculated by the computer, based on the IDS/HISTORY data base for the lower confidence value (in  $\text{mg}/\text{m}^3$ ). Values were printed only for work area samples.
- g. Upper 95% - the value calculated by the computer, based on the IDS/HISTORY data base for the upper confidence value (in  $\text{mg}/\text{m}^3$ ). Values were printed only for work area samples.
- h. Time - sampling interval.

The IDS/HISTORY tape contained statistical limits, established by USATHAMA and the Department of Health and Human Sciences (DHHS), used for accuracy and precision charts. These charts provided the upper and lower bounds for accuracy of measurements (mean value) and the precision (standard deviation) or variance of mean readings.

CALIBRATION OF INSTRUMENT RESPONSE GBR - 4

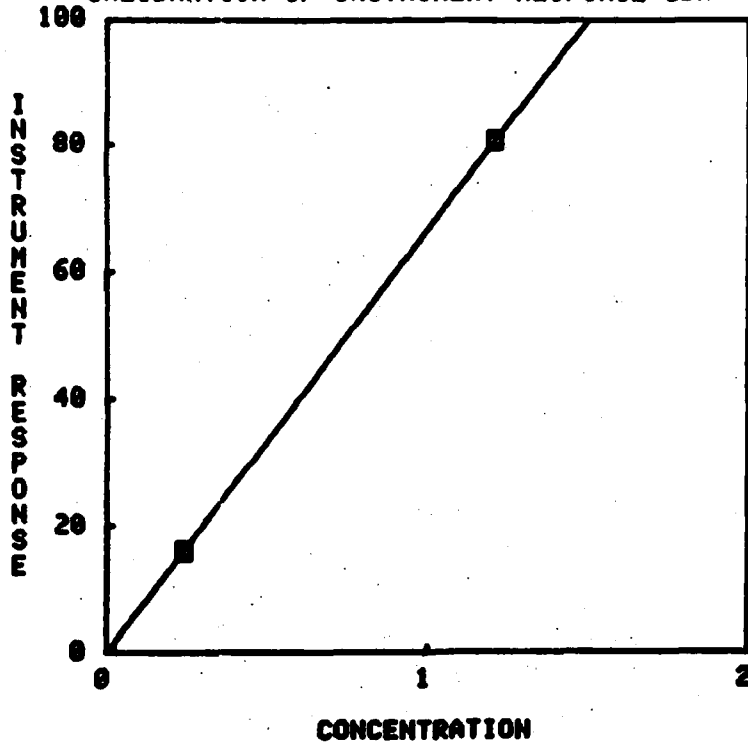

AGENT: H  
DATE: 11/17/81

STATISTICS

BARTLETTS:  
0.752  
R-SQUARED:  
1.000  
MSE:  
3.943E-002

PARAMETERS

$Y' = a + bX'$   
a = -2.850E-002  
b = 6.686E+001  
 $Y' = (Y + f) + g$   
 $X' = X + h$   
f = 0.000E+000  
g = 1.000E+000  
h = 0.000E+000

Figure 26

ACTUAL DATA FOR H

DATE: 07/14/81

AGENT CONCENTRATION

SAMPLE	LOCATION	TRUE	LOWER 95%	UPPER 95%
AYEH04	DR	0.000x		
AYFH02	ST	0.000x		
AYFH03	CR	0.000x		
AYFH05	RA	0.000x		
AYFH06	DR	0.000x		
AYGH03	DR	0.000x		
AYHH01	DR	0.000x		
AYHH03	RA	0.000x		
AYHH04	CR	0.000x		
AYHH06	ST	0.001		
AYIH01	DR	0.000x		
AYIH04	CR	0.000x		
AYIH05	RA	0.000x		
AYIH06	DR	0.000x		
AYIH07	ST	0.000x		

Figure 27

Accuracy and precision charts (see Figures 28 through 29) were produced as quality control with respect to the laboratory and the calibration chart for each day. The measurements of each of four bubblers, spiked with known concentrations of 0.04 and 0.216  $\mu\text{g}/\text{ml}$ , were averaged to determine the accuracy. USATHAMA and DHHS had established upper and lower limits for accuracy measurements for mustard agent as follows:

MEAN CONCENTRATION	LIMITS	
	LOWER	UPPER
0.04 $\mu\text{g}/\text{ml}$	0.023 $\mu\text{g}/\text{ml}$	0.057 $\mu\text{g}/\text{ml}$
0.216 $\mu\text{g}/\text{ml}$	0.191 $\mu\text{g}/\text{ml}$	0.241 $\mu\text{g}/\text{ml}$

Daily points should scatter about the mean. Points above the upper line or below the lower line constituted the measuring process as being "out-of-control." Seven continuous runs above or below the mean line also constituted the measuring process as being "out-of-control."

Precision charts indicated the standard deviation of the mean accuracy readings. Average deviations, using past data as a base, had been established of 0.04 and 0.216 concentrations, as follows:

CONCENTRATION	AVG. DEVIATION	UPPER LIMIT
0.04 $\mu\text{g}/\text{ml}$	0.009	0.029
0.216 $\mu\text{g}/\text{ml}$	0.013	0.042

It was expected that precision calculations would scatter above and below the average deviation. The desirable situation was for all calculations to fall between 0 and the upper limit. If a point fell above the upper limit, the measuring process was considered to be "out-of-control." After an initial period of operations, control charting and quality control at the 0.04  $\mu\text{g}/\text{ml}$  level was discontinued. Quality control at 0.216  $\mu\text{g}/\text{ml}$  continued throughout all operations.

#### 4.3 DESCRIPTION OF INVENTORY DATA COLLECTION

For the CAIS disposal program, inventory control can be divided into two basic categories: incoming or receipt inspection; and outgoing or process recording. Receipt inspection for Phase I consisted of recording the serial numbers of incoming ID Sets (pigs and boxes) and noting that they were either destroyed or returned to the toxic storage yard. Process inspections were conducted to record any unusual observations in the disassembly room (leakers, rusted cans, etc.) and the final disposition of the pigs, furnace residue, and the salts from the spray dryer and the electrostatic precipitator.

##### 4.3.1 RECEIPT INSPECTION

Each day the Bldg. 1611 Receipt Inspection form was delivered to the computer group for processing. The data entry and data print programs were used to insert and verify the entry of the data. After corrections (if any) were made, the day's report was run. The report showed the date, serial number of received ID Sets, whether they were destroyed or returned to the toxic storage yard, and pertinent comments.

ACCURACY CONTROL CHART FOR H QL.216  
 HQH QL.216

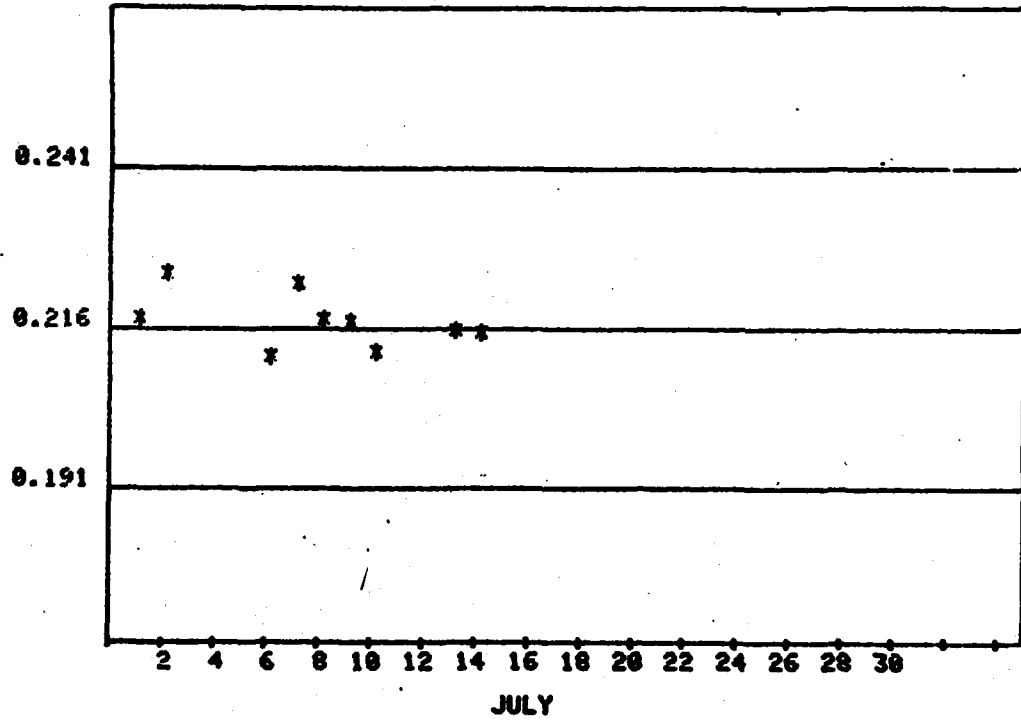

Figure 28

PRECISION CONTROL CHART FOR H QL.216  
 HQH QL.216

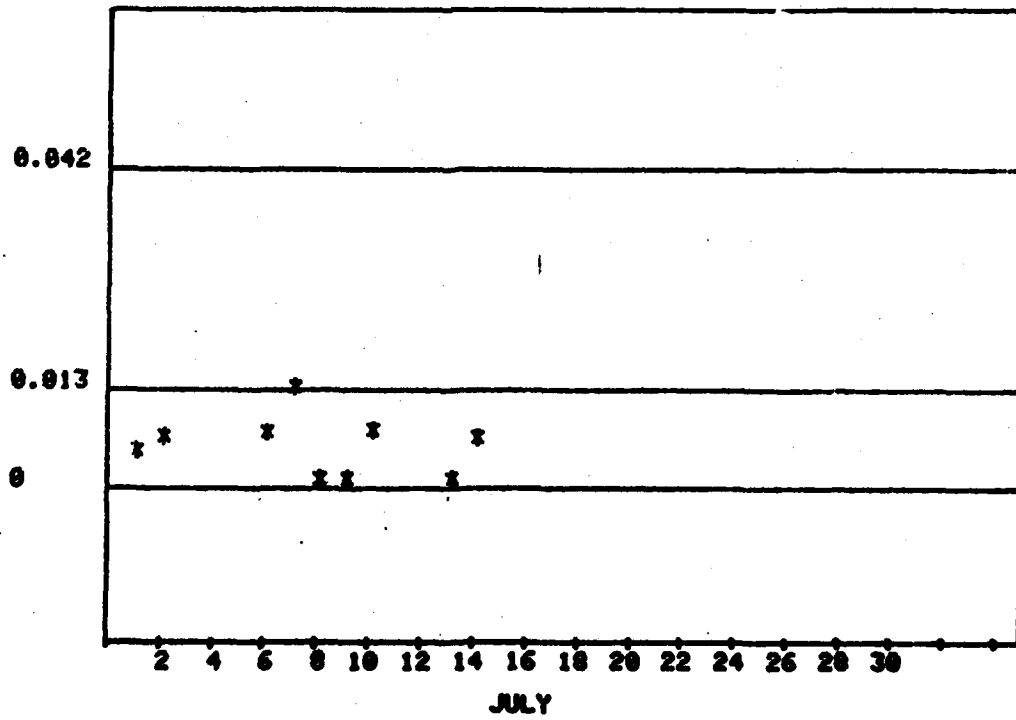

Figure 29

#### **4.3.2 PROCESS INSPECTION**

The process data sheet for the disassembly room for the current day was delivered to the computer group. The data sheet contained notes on any unusual occurrences or observations for the day's operation. If there were none noted for the day, the data sheet was not taken to the computer group. The data was processed in the same manner as other data entry/print programs and produced a report showing the ID Sets type, serial number, any unusual occurrence or observation, and action taken.

#### **4.3.3 FINAL DISPOSITION**

Data sheets from the residue area (daily), and spray dryer and electrostatic precipitator (as required) were processed by the computer group. Processing procedures were the same as for other data sheets. Reports were produced as follows:

- a. Decontaminated (Deconned) pigs
- b. Furnace residue (drums)
- c. Spray dryer residue (drums)
- d. Electrostatic precipitator residue (drums)

#### **4.3.4 DATA CONVERSION**

All inventory data for the day was converted to Univac 1108 format and sent to USATHAMA, in accordance with the details of Paragraph 4.1.5.

#### **4.4 DESCRIPTION OF DOWNTIME DATA COLLECTION**

A coded downtime data sheet was provided each day, even for those days when there was no downtime. Data was processed in the same manner as other program inputs: ie: entered, verified, corrected as required, and reports generated. The reports were printed with definitions rather than the numerical-code data entries. These reports provide the following information:

- a - Date
- b - Start and Stop times of the downtime.
- c - Whether or not this was a simultaneous experience with other malfunctions.
- d - Subsystem affected.
- e - Primary components affected
- f - Secondary components affected
- g - Description action
- h - Failure modes
- i - Corrective action taken
- j - Effect on operation
- k - Operator comments

If there was no downtime experienced during the day, the report so stated. Thus, there was a downtime report each day.

The downtime report data was converted to Univac 1108 format and sent to USATHAMA, in accordance with the procedures outlined in Paragraph 4.1.5.

## **CHAPTER 5 CONCLUSIONS AND RECOMMENDATIONS**

### **5.1 INTRODUCTION**

The purpose of this section is to provide a summary of lessons learned which can be applied to future phases of the ID Sets operation as well as other demilitarization programs. The conclusions will be collected into the three functional areas of demilitarization operations, which are: plant operations, laboratory operations, and data center operations. It must be emphasized that the overall demilitarization operation was found to operate as a "tripod"; that is that all three functional areas had to be simultaneously operational. No two of the functional areas could be allowed to continue operation if the remaining area was experiencing problems which kept it from functioning properly. This is the first time that a demilitarization program has been run such that the data center operations and laboratory operations were considered a prerequisite for daily plant operations. It is also the first time that daily quality control acceptance criteria were used as a prerequisite for daily plant operations.

### **5.2 PLANT OPERATIONS**

#### **5.2.1 GENERAL**

In looking at how the plant operated during the period of 8 May 1981 to 28 January 1982 there are three areas which must be evaluated. These are as follows:

1. Air Monitoring results
2. Disassembly room operations and set characteristics
3. Downtime analysis

#### **5.2.2 AIR MONITORING RESULTS**

The air monitoring results in specific terms are addressed in Chapter 4. In general terms, and in the form of conclusions, a number of findings can be made as follows:

- 5.2.2.1 The concepts of removing the worker from the ID Sets to a maximum extent and minimizing set disassembly were major factors in the almost total lack of disassembly room readings. The one operation which occurs outside of the glovebox—bolt replacement—was responsible for two of the five minimal readings recorded. It is noteworthy that this occurred during a violation of Standing Operating Procedures. The conclusion is that it is better to build safety into the materials handling equipment than it is to try to write it into the procedures.
- 5.2.2.2 Forklift exhaust and/or dry gas additive cause a positive indication in the DB3 colorimetric analysis for mustard. This can be eliminated, however, by the use of a gas chromatographic verification.
- 5.2.2.3 It was concluded from the overall plant air monitoring results over the period of 21 December 1981 - 26 January 1982 that unburned fuel oil vapor in an incineration system can cause low level positive indications for mustard in the DB3 colorimetric

analysis technique. This is particularly aggravated in work areas by cold, still conditions. It is also seen where the workers close doors to keep out the chill winds and, in so doing, allow fuel oil vapor to build up. It should be noted that the gas chromatographic verification does not work in distinguishing this type of reading due to a peak with similar retention time in the fuel oil spectrum. The following are recommendations to mitigate this condition:

- a. In future demilitarization incinerator designs, further attention should be paid to ventilating non-toxic work areas to prevent a build up of fuel oil vapor, particularly in residue disposal areas.
- b. Future designs of demilitarization systems should attempt to minimize fuel oil leakage around furnaces, afterburners, and in work areas to allow for more accurate air monitoring data.
- c. The separation of the fuel oil pump transfer station from plant facilities is advisable due to fuel oil vapor build up which is unavoidable at this point. This has a definite negative effect on cold weather bubbler results for mustard.
- d. Over an operational period of seven months, only one reading was recorded (26 May 81, .042  $\mu\text{g}/\text{m}^3$ , stack) which exceeded either work area or stack standards agreed to by the Department of the Army, the Department of Health and Human Services, and the State of Colorado. This reading was the result of a transitory upset which was quickly corrected and represented by itself no threat to the work force or the environment. It is again noteworthy that this was the result of running the deactivation furnace in an improper mode in violation of Standing Operating Procedures. This was unintentional and due to operator error. The RMA response to this event was the installation of a "K941/K942 mode" switch on the deactivation furnace panel which automatically performed the function properly. Again, the design of the control equipment to handle the function was proved to be more effective than attempting to handle the problem procedurally.

### 5.2.3 DISASSEMBLY ROOM OPERATIONS AND SET CHARACTERISTICS

#### 5.2.3.1 Box Sets

The X-Sets packaged into wooden boxes were generally in good condition. They did not appear fundamentally different than those which were destroyed in the 1979 Pilot Test. These sets were generally handled without incident, although a number became jammed in the chute or resulted in breaking the pins upon which the "flapper" — a counting mechanism installed in the feed chute — was hung. All of these were cleared to the furnace without incident.

#### 5.2.3.2 Pig Sets

- a. K941/K942. The K941/K942 pig sets encountered during the 1981-1982 production run were significantly more deteriorated than those encountered in 1979 during the Pilot Test. This is to some extent due to the prolonged storage of about 800 of the total 847 of these items on Johnston Atoll. This was

particularly true for the eight bolts around the flanged end of the pig. The salt air had rusted these to such an extent that even the impact wrenches used in the glovebox could not easily free the bolts. A manual one-for-one replacement operation using special tools was performed at the loading station to alleviate this problem. It is suggested that items stored on Johnston Atoll in overpacks be physically inspected prior to designing materials handling or unpack equipment such that problems caused by the highly corrosive environment will be anticipated.

The interior of the K941/K942 sets were also significantly worse than expected. The incidence of leaking sets was, for all intents and purposes, 100%. Many cans were significantly deteriorated and mustard leakage within the glovebox was common. Although an unusually high amount of cardboard overpacks were used during this period, no other problems were caused by this condition. There is no question that the glovebox operation was essential in preventing mustard exposure of the workers.

- b. X-Sets. A certain group of X-sets, specifically those packaged at Aberdeen Proving Ground, were placed into pigs prior to shipment. These items were handled in the same mode as K941/K942 sets and were handled without incident.

#### **5.2.3.3 Engineering Drawings**

During the development of the equipment to process both pigs and boxes, U.S. Army drawings of the ID Sets were used to prepare process equipment. It cannot be emphasized enough that these drawings were frequently in error or incomplete. The item, be it a box or a pig, was rarely delivered as shown or described on the engineering drawings. It is imperative in designing equipment for future demilitarization that the actual items to be destroyed should be physically surveyed for key design parameters or mistakes made in this regard on the ID Sets program will be repeated.

#### **5.2.4 DOWNTIME ANALYSIS**

##### **5.2.4.1 General**

There are a number of methods as to how downtime should be calculated (refer to Paragraph 2.4.1). As this is essentially a production oriented operation, I have chosen as a management yardstick the number of sets "produced" — therefore destroyed — on any given day versus the number of those type of sets which should have been destroyed on a normal full production day. This is the calculation made to produce "process downtime." By month, this "process downtime" is shown as follows:

**Table 6  
Downtime Analysis By Sets Destroyed**

Month	Days Of Scheduled Opns	Sets Destroyed	Sets Scheduled	Percent Downtime
May 81	15	420	984	57.3%
Jun 81	22	548	912	39.9%
Jul 81	11	484	600	19.3%
Sep 81	10	270	576	53.1%
Oct 81	21	928	1368	32.2%
Nov 81	19	447	600	25.5%
Dec 81	22	441	864	49.0%
Jan 82	19	1096	1176	6.8%

Using the results of Table 6 and calculating downtime by an average weighted by days results in the following calculation:

$$1. \frac{(57.3 \times 15) + (39.9 \times 22) + (19.3 \times 11) + (53.1 \times 10) + (32.2 \times 21) + (25.5 \times 19) + (49.0 \times 22) + 6.8(19)}{(15) + (22) + (11) + (10) + (21) + (19) + (22) + (19)}$$

$$2. \frac{859.5 + 877.8 + 212.3 + 531 + 1115.8 + 484.5 + 1078.0 + 129.2}{139}$$

$$3. \frac{5288.1}{139} = 38\% \text{ or } 53 \text{ lost days out of } 139 \text{ potential operating days.}$$

This total represents, at least initially, a higher figure than the 30% predicted in the Pilot Test report. Two major contributing factors to this 38% figure were a lightning strike which destroyed the plant microprocessor (3.6% or 5 days) and the failure of the deactivation furnace conveyor (6.5% or 9 days). These two items alone account for 10.1% of the available processing time of 139 days. Downtime excepting these two major failures then drops to 27.9%.

Another contributing factor was startup which saw an unusually high downtime figure of 57.3% for the month of May. Generally speaking, downtime improved considerably as the operation progressed. This is somewhat mitigated by the December 1981 figure, but that month is traditionally one when higher downtime is experienced due to the holidays and cold weather problems. The month of January 1982 was unusually trouble-free, but the weather was also unusually mild for the later part of the month.

#### 5.2.4.2 Specific Action

Excepting the two major failures of the microprocessor and the deactivation furnace conveyor, downtime has occurred primarily in the decontamination furnace subsystem and in a number of cold weather related areas. Other causes have been essentially random among the various process modules. Given this situation the following actions are being taken:

- a. All exposed water/fuel lines are being extensively heat traced. Old heat tracing is being replaced, as a good deal of this has been found to be defective.
- b. The preventive maintenance program is being revitalized by the use of extensive contractor assistance. This is in response to limiting the various random failures experienced.

#### 5.2.4.3 Conclusions

Some conclusions and recommendations in observing the downtime encountered on the ID Set Program and attempting to extrapolate the experience to other future work is as follows:

- a. Preventive Maintenance

The initial attempt to staff this work with the three full time maintenance people currently available has been a failure. This is due to a constant demand for these people to handle unscheduled maintenance. It is obvious that this area has been undermanned and future demilitarization projects should look toward adequately manloading it with personnel separate from the unscheduled maintenance personnel.

- b. Furnace Operation

As an overall comment, the constant shutting down and firing up of furnaces every weekend at RMA has definitely taken a toll on the equipment. While this is unavoidable at RMA with the current manpower constraints, it should be studiously avoided in planning for operations of other facilities. Other lessons learned include the following:

- (1) Include on the control panel the ability to monitor the status of fuel oil storage.
- (2) Include flow meters on all fuels lines to indicate oil usage. This would undoubtedly provide clues or early warning for burner malfunctions.
- (3) For cold weather facilities (all CONUS) provide testing of all plant heat tracing every fall, particularly for fuel lines. If possible, design these lines such that they are inside, not outside, the facility or run underground.
- (4) Use of the Kaiser product "Helskote" has greatly relieved slagging at the afterburner throats and has enabled these to be cleaned rapidly. Maintenance to clean the burner throats is scheduled once a week, on the weekend.

- c. Microprocessor Operation

This unit, while essential to various plant operations, has not been as trouble-free as was first expected. When using a microprocessor to control plant functions, two important "back-up" strategies should be maintained:

- (1) A spare unit should be kept plugged in and pre-programmed to reduce switch-over time if the primary unit fails.

**(2) Back-up magnetic tapes of the microprocessor programs should be strictly maintained and kept up to date. Also a log of all program changes should be maintained.**

## DISTRIBUTION LIST

Names	Copies
<b>Commander</b> <b>U.S. Army Toxic and Hazardous Materials Agency</b> <b>Aberdeen Proving Ground, MD 21010</b> <b>Attn: DRXTH-SE</b> <b>Attn: DRXTH-ES</b>	<b>20 Copies</b> <b>2 Copies</b>
<b>Commander</b> <b>Rocky Mountain Arsenal</b> <b>Commerce City, Colorado 80022</b> <b>Attn: SARRM-TO</b>	<b>10 Copies</b>
<b>DP Associates Field Office</b> <b>Rocky Mountain Arsenal</b> <b>Commerce City, Colorado 80022</b> <b>Attn: Dr. Jack Pantleo</b>	<b>4 Copies</b>
<b>Defence Technical Information Center</b> <b>Cameron Station</b> <b>Alexandra, VA 22314</b>	<b>12 Copies</b>
<b>Defense Logistics Studies Information Exchange</b> <b>U.S. Army Logistics Management Center</b> <b>Fort Lee, VA 23801</b>	<b>2 Copies</b>
<b>Commander</b> <b>U.S. Army Armament Command</b> <b>Rock Island, IL 61299</b> <b>Attn: DRSAR-DR (Mr. Lathrop)</b> <b>Attn: DRSAR-ASN (Mr. Baker)</b> <b>Attn: DRSAR-PEC (Mr. Cecil)</b>	<b>1 Copy</b> <b>1 Copy</b> <b>1 Copy</b>
<b>Commander</b> <b>U.S. Army Development and Readiness Command</b> <b>5001 Eisenhower Avenue</b> <b>Alexandria, VA 22333</b> <b>Attn: DRCNC</b>	<b>5 Copies</b>

AD-A120 849

DISPOSAL OF CHEMICAL AGENT IDENTIFICATION SETS AT ROCKY  
MOUNTAIN ARSENAL..(U) ARMY TOXIC AND HAZARDOUS  
MATERIALS AGENCY ABERDEEN PROVING GR..

22

UNCLASSIFIED

W R BRANKOWITZ ET AL. JUL 82

F/G 15/2

NL

				END
				DATE
				FILMED
				8 83
				DTIC

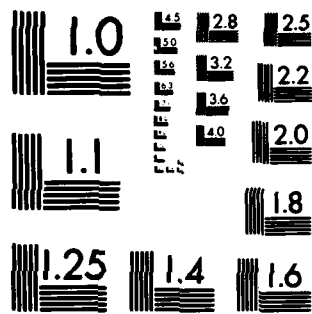

MICROCOPY RESOLUTION TEST CHART  
NATIONAL BUREAU OF STANDARDS-1963-A

**SUPPLEMENTARY**

**INFORMATION**

AD-7120849

updated

TYPE OF SET DATE	K941/K942	X302	X547	X550	X551
1/6/82	22				
1/8/82					75
1/11/82					30
1/12/82					45
1/13/82					90
1/14/82					75
1/15/82					90
1/18/82					70
1/19/82					84
1/20/82					75
1/21/82					90
1/22/82					75
1/25/82					60
1/26/82		1		8	59
1/27/82				22	3
1/28/82					25
<hr/> TOTAL	<hr/> 802	<hr/> 82	<hr/> 1202	<hr/> 1302	<hr/> 1246

PD-A/26849

updated

**Table 6  
Downtime Analysis By Sets Destroyed**

Month	Days Of Scheduled Opns	Sets Destroyed	Sets Scheduled	Percent Downtime
May 81	15	420	984	57.3%
Jun 81	22	548	912	39.9%
Jul 81	11	484	600	19.3%
Sep 81	10	270	576	53.1%
Oct 81	21	928	1368	32.2%
Nov 81	19	447	600	25.5%
Dec 81	22	441	864	49.0%
Jan 82	19	1096	1176	6.8%

Using the results of Table 6 and calculating downtime by an average weighted by days results in the following calculation:

1. 
$$\frac{(57.3)(15) + (39.9)(22) + (19.3)(11) + (53.1)(10) + (32.2)(21) + (25.5)(19) + (49.0)(22) + 6.8(19)}{(15) + (22) + (11) + (10) + (21) + (19) + (22) + (19)}$$
2. 
$$\frac{859.5 + 877.8 + 212.3 + 531 + 676.2 + 484.5 + 1078.0 + 129.2}{139}$$
3. 
$$\frac{4848.5}{139} = 34.9\% \text{ or } 49 \text{ lost days out of } 139 \text{ potential operating days.}$$

This total represents, at least initially, a higher figure than the 30% predicted in the Pilot Test report. Two major contributing factors to this 34.9% figure were a lightning strike which destroyed the plant microprocessor (3.6% or 5 days) and the failure of the deactivation furnace conveyor (6.5% or 9 days). These two items alone account for 10.1% of the available processing time of 139 days. Downtime excepting these two major failures then drops to 24.8%.

Another contributing factor was startup which saw an unusually high downtime figure of 57.3% for the month of May. Generally speaking, downtime improved considerably as the operation progressed. This is somewhat mitigated by the December 1981 figure, but that month is traditionally one when higher downtime is experienced due to the holidays and cold weather problems. The month of January 1982 was unusually trouble-free, but the weather was also unusually mild in the later part of the month.

#### 5.2.4.2 Specific Action

Excepting the two major failures of the microprocessor and the deactivation furnace conveyor, downtime has occurred primarily in the decontamination furnace subsystem and in a number of cold weather related areas. Other causes have been essentially random among the various process modules. Given this situation the following actions are being taken:

**DATE**  
**ILME**