

AD-A121 318

SOLAR THERMOCHEMICAL ENERGY CONVERSION AND TRANSPORT
(U) NEW MEXICO STATE UNIV LAS CRUCES PHYSICAL SCIENCE
LAB J H MCCRRARY ET AL. 10 NOV 82 NMSU/PSL-P501010
N00014-77-C-0229

1/1

UNCLASSIFIED

F/G 10/2

NL

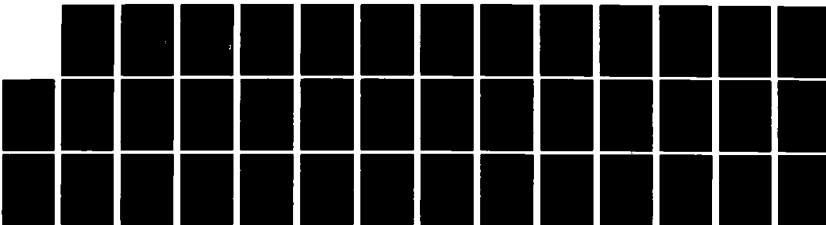

END

FORM
1
DTC

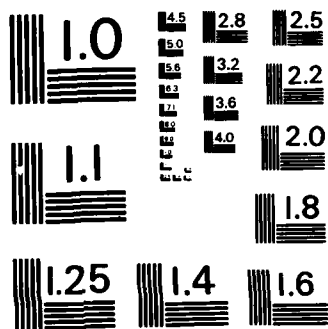

MICROCOPY RESOLUTION TEST CHART
NATIONAL BUREAU OF STANDARDS-1963-A

SOLAR THERMOCHEMICAL ENERGY CONVERSION AND TRANSPORT

J.H. McCrary
Gloria E. McCrary
Physical Science Laboratory
New Mexico State University
Las Cruces, NM 88003-3548

10 November 1982

FINAL REPORT
15 March 1977 - 30 September 1982

prepared for:

Naval Research Laboratory
4555 Overlook Ave., S.W.
Washington, D.C. 20375

ONR Resident Representative
Department of the Navy
Bandolier Hall West - Room 204
University of New Mexico
Albuquerque, NM 87131

STIC
ELECTED
NOV 12 1982
H

DISTRIBUTION STATEMENT A
Approved for public release;
Distribution Unlimited

ADA121318

STIC FILE COPY



Physical Science Laboratory

BOX 3548, LAS CRUCES, NEW MEXICO 88003-3548
AREA (505) 522-9100 TWX 910-883-0641

82 11 12 010

UNCLASSIFIED

SECURITY CLASSIFICATION OF THIS PAGE (When Data Entered)

REPORT DOCUMENTATION PAGE		READ INSTRUCTIONS BEFORE COMPLETING FORM
1. REPORT NUMBER	2. GOVT ACCESSION NO. A121318	3. RECIPIENT'S CATALOG NUMBER
4. TITLE (and Subtitle) SOLAR THERMOCHEMICAL ENERGY CONVERSION AND TRANSPORT		5. TYPE OF REPORT & PERIOD COVERED FINAL REPORT 15 March 1977 - 30 Sept 1982
		6. PERFORMING ORG. REPORT NUMBER PSL #PS01010
7. AUTHOR(s) J.H. McCrary, Gloria E. McCrary		8. CONTRACT OR GRANT NUMBER(s) N00014-77-C-0229
9. PERFORMING ORGANIZATION NAME AND ADDRESS Physical Science Laboratory New Mexico State University Las Cruces, NM 88003-3548		10. PROGRAM ELEMENT, PROJECT, TASK AREA & WORK UNIT NUMBERS
11. CONTROLLING OFFICE NAME AND ADDRESS Naval Research Laboratory 4555 Overlook Avenue, S.W. Washington, D.C. 20375		12. REPORT DATE 10 November 1982
		13. NUMBER OF PAGES 36
14. MONITORING AGENCY NAME & ADDRESS (if different from Controlling Office) G. Max Irving ONR Resident Representative University of New Mexico - Bandolier Hall, West Albuquerque, NM 87131		15. SECURITY CLASS. (of this report) UNCLASSIFIED
		15a. DECLASSIFICATION/DOWNGRADING SCHEDULE
16. DISTRIBUTION STATEMENT (of this Report) Approved for public release; distribution unlimited.		
17. DISTRIBUTION STATEMENT (of the abstract entered in Block 20, if different from Report) Approved for public release; distribution unlimited.		
18. SUPPLEMENTARY NOTES		
19. KEY WORDS (Continue on reverse side if necessary and identify by block number) Solar Energy Thermochemistry Energy Conversion		
20. ABSTRACT (Continue on reverse side if necessary and identify by block number) The high temperature catalytic dissociation of SO ₃ and the CO ₂ -CH ₄ reforming-methanation cycle are important chemical processes being considered in the development and application of solar-thermal energy conversion, transport, and storage systems. Separate facilities for		

DTIC

NOV 12 1982

H

DD FORM 1 JAN 73 1473

EDITION OF 1 NOV 65 IS OBSOLETE

UNCLASSIFIED

SECURITY CLASSIFICATION OF THIS PAGE (When Data Entered)

evaluating chemical converter-heat exchangers at temperatures to 1000°C with high flow rates of SO₃ and of mixtures of CO₂ and CH₄ feedstocks have been assembled and operated on the NMSU campus. A number of receiver elements (chemical reactors) have been tested in these laboratory facilities in an effort to optimize catalyst parameters and catalyst reactor configurations. These tests led to the design and fabrication of both low power and high power solar energy receivers which were operated successfully at the White Sands Solar Furnace. Energy delivery methanation reactor design and parametric studies led to the fabrication and operation of a laboratory closed-loop, energy conversion, transport, and delivery system. These latter experiments met with limited but promising success. Carbon deposition, though a problem, is believed to be controllable with the optimization of catalyst parameters and feedstock composition.

Table of Contents

	Page No.
I. INTRODUCTION.	1
II. SO ₃ DISSOCIATION EXPERIMENTS.	2
III. CO ₂ -CH ₄ REFORMING EXPERIMENTS	4
IV. CLOSED LOOP EXPERIMENTS	6
V. CONCLUSIONS	9
VI. FIGURES	11
VII. DISTRIBUTION LIST	36



Accession For	
NTIS GRA&I	<input checked="" type="checkbox"/>
DTIC TAB	<input type="checkbox"/>
Unannounced	<input type="checkbox"/>
Justification	
By _____	
Distribution/	
Availability Codes	
Avail and/or	
Dist	Special
A	

I. INTRODUCTION

Thermochemical capture of solar energy - Solchem - is an important concept in the development of economical, practical, alternate energy systems¹⁻⁴. Solchem provides an alternative to the more conventional method of transporting solar thermal energy to directly drive a heat engine power cycle. Solchem involves the use of the high temperature heat available from concentrating collectors to activate an energy absorbing chemical reaction which will then produce an energy rich chemical product. The thermochemical receivers involve no moving parts, only gas passages and catalytic surfaces.

Two gaseous chemical fluids have been considered for thermochemical energy conversion systems. These are SO_3 and a mixture of CH_4 and CO_2 . The SO_3 dissociation reaction may be written as

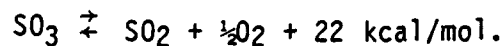

The forward reaction is used in a receiver to convert solar energy into chemical heat of reaction. This energy is then transported and is deposited in a storage system via the reverse reaction. The use of SO_3 as a working fluid offers the following advantages: (1) the lack of side chains in the chemical reaction; (2) the sensitivity of the reaction to control by catalysis; (3) the relatively low gas pressures

-
1. T.A. Chubb, Analysis of gas dissociation solar thermal power system. *Solar Energy* 17, 129 (1975).
 2. T.A. Chubb, J.J. Nemecek and D.E. Simmons. Application of chemical engineering to large scale solar energy. *Solar Energy* 20, 219 (1978).
 3. T.A. Chubb, J.J. Nemecek and D.E. Simmons, Design of small thermochemical receiver for solar thermal power. *Solar Energy* 23, 217 (1979).
 4. T.A. Chubb, Characteristics of CO_2 - CH_4 reforming-methanation cycle relevant to the solchem thermochemical power system. *Solar Energy* 24, 341 (1980).

involved; and (4) the temperature range of gas dissociation and recombination. The disadvantages are: (1) toxicity; (2) incompatibility with low cost materials; (3) corrosiveness at receiver temperature; and (4) poor thermal conductivity.

The CO₂-CH₄ reforming-methanation reactions and the accompanying shift reaction can be written as

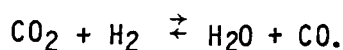
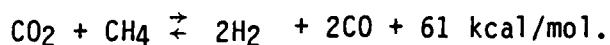

The reforming chemical cycle offers the following advantages: (1) the relative nontoxicity of the components of the working fluids; (2) the low pressure and temperature requirements for both feedstock and synthesis gases; (3) the compatibility of the working fluids with low cost materials; and (4) no serious corrosion problems at receiver temperature. The disadvantages are: (1) complicated chemistry with several possible side reactions; and (2) carbon deposition can be a problem.

The work performed under this contract falls into three categories. These are: (1) SO₃ dissociation experiments; (2) CO₂-CH₄ reforming experiments; and (3) methanation and closed-loop experiments.

II. SO₃ DISSOCIATION EXPERIMENTS

Although SO₃ is a toxic chemical, there are well established rules for handling the material which have led to production rates of 2x10¹⁰ kg/yr. In addition, SO₃ is the end product of SO₂, which is introduced into the atmosphere in enormous quantities during the burning of coal.

Its use in a closed loop energy conversion and transport process thus imposes negligible ecological problems. The use of SO_3 does, however, involve significant material problems. At 100°C , these problems are not severe, although common material choices are largely restricted to Teflon, mild steel, stainless steel, glass, quartz and ceramics. At receiver temperature (1000°C), Teflon and steel are not usable. While there are indications that aluminium rich alloys, such as Kanthal A-1, may be usable, the materials of choice for SO_3 energy converters are fused silica and ceramics.

The objective of the present work is to measure the dissociation efficiency of several reactor-catalyst configurations. A facility was assembled at NMSU which permitted the testing of prototype Solchem SO_3 dissociation reactors under conditions similar to those which would be encountered in a full-scale solar power conversion plant. A typical reactor with its counter-current heat exchanger is configured as a flat helix whose outer diameter is 0.75 m and whose inner diameter is 0.30 m. This test article is positioned in a furnace in such a manner that only the innermost turn of the helix, the converter turn which contains the catalyst, is heated. Electrical heaters, simulating the focussed solar beam, were located within a cavity which was surrounded by the reactor's inner (converter) turn. The test facility does not utilize closed-loop operation; gaseous feedstock, evaporated from liquid SO_3 , was introduced to the reactor at controlled temperature, pressure, and flow rate. The reactor effluent was completely scrubbed after being analyzed to prevent the release of SO_2 or SO_3 to the environment. From the molar fraction of SO_2 measured in the effluent gas the power converted to chemical heat of reaction was calculated.

From September 1979 through September 1980, twenty-five separate tests were conducted in the SO_3 laboratory on four separate reactors. The conditions attending these tests and the experimental results have been published^{5,6}. Conversion powers of 2kW with conversion efficiencies of greater than 50% were observed in these single coil tests.

III. CO₂-CH₄ REFORMING EXPERIMENTS

A facility was assembled at NMSU in which reforming converter-heat exchangers were tested under conditions similar to those which would be encountered in a full-scale solar power conversion plant. A typical reformer was configured as a helical, tube-in-tube, counter-current heat exchanger surrounding a single turn converter in which the reforming reaction is catalyzed. Most of the receiver elements studied in this work were fabricated from type 316 stainless steel tubing. Other materials, including types 304 and 310 stainless steel and Kanthal A-1 tubing, have also been utilized. In nearly all of the (approx. 20) reactors tested, the outer diameter of the outer tube was 25.4 mm while that of the inner tube was 15.9 or 19.0 mm. The wall thickness of these tubes is typically 1.2 mm. Heat exchanger lengths have varied from 4 to 6 turns. In some of the reactors the converter turn was the inner turn of the helix, while in others a circular converter, manifolded to the heat exchanger, was used. A number of catalyst and catalyst configurations were tested. In the first reactor tested, the converter was loaded with small (6x6 mm) alumina pellets which were coated with NiO catalyst. Other converters studied during the first phase (1979) of the program contained NiO coated alumina Raschig rings. The number and distribution of these rings within the converter tube were varied and optimized early in the project.

Early in the project it was found that catalyst deterioration was an important problem. In an effort to circumvent this difficulty, different catalyst configurations and materials were studied. A short

5. J.H. McCrary and Gloria E. McCrary, "Evaluation of Metallic Converters," Final Report submitted to California Institute of Technology, Jet Propulsion Laboratory, Pasadena, Calif. Contract No. 955704, December 1980.

6. J.H. McCrary, Gloria E. McCrary, T.A. Chubb, and Y.S. Won, "An Experimental Study of SO₃ Dissociation as a Mechanism for Converting and Transporting Solar Energy," *Solar Energy* 27, 433 (1981).

sequence of tests was conducted with tubewall reactors. These converters contained Ni catalyst material deposited directly on the inner wall of the converter tubes. For the tubewall converters tested the conversion efficiency was unacceptably low. The most successful catalyst material used in the reforming work was ruthenium. The material was in the form of small, perforated stainless steel saddles, coated with a ruthenium bearing surface layer. The converter tube was tightly packed with the Ru coated stainless steel saddles. The Ru catalyzed reactors were found to have good long-term stability. During ten months of tests and experimentation there was no evidence of catalyst deterioration.

Two solar energy receivers were assembled and operated at the White Sands Solar Furnace in December 1979 and January 1981 respectively. At this facility, the full power of the furnace is concentrated within a conical envelope with a half angle of 45° and a focal spot of less than 10 cm dia. In December 1979 the full power capability of the furnace was 30 kW; in January 1981, 26 kW was the maximum power available.

From May 1979 through January 1981 approximately eighty separate tests were conducted in the reforming laboratory at NMSU and at the White Sands Solar Furnace. These tests involved some twenty reactors utilizing many different catalyst-converter configurations. The results of this work have been published⁷⁻¹¹.

7. J.H. McCrary, Gloria E. McCrary, and D.H. Clark, "Solchem Thermochemical Tests and Demonstrations at NMSU," Proceedings, 1980 Annual Meeting, American Section, International Solar Energy Society, Inc. Vol 3.1, 99 (1980).

8. J.H. McCrary, Gloria E. McCrary, and T.A. Chubb, "Solchem Thermochemical Demonstration at the White Sands Solar Furnace," Proceedings, 1980 Annual Meeting of Solar Thermal Test Facility Users Association.

9. "Solar-Chemical Energy Converter Tested," Chemical and Engineering News 57, 26 (July 30, 1979).

IV. CLOSED-LOOP EXPERIMENTS

Relatively little work has been done on the energy delivery part of the Solchem system. An attempt was made to operate an ordinary re-forming receiver element as a methanator. The synthesis gas used as the feedstock in these tests consisted of mixture of 3 parts (by volume) CO to 3 parts H₂ to 2 parts CO₂. From the results of this work it was concluded that a good reformer is not necessarily a good methanator. The results, however, did indicate that methanation reactivity would be improved if the space velocity could be reduced by a large factor. A methanation reactor was then fabricated which was similar to the reformer receiver elements except that the converter turn was made from 5.08cm O.D. stainless steel tubing with 1.2mm thick walls. The converter was loaded with tightly packed NiO Raschig rings of the type described earlier. With space velocities in the range of 500 hr⁻¹, this reactor was found to perform well as a methanator, delivering about 1kW of heat while producing an effluent gas which contained 25% CH₄ and less than 5% CO from the 3:3:2 feedstock described above¹⁰.

From April through October 1981 a sequence of experiments was performed in the NMSU Solchem reforming laboratory to demonstrate a low-power, laboratory model, closed-loop, energy delivery system. Figure 1 shows a chemical engineering flow chart for the system. Included in the chart are temperatures and pressures at various points in the loop.

10. J..H. McCrary, Gloria E. McCrary, T.A. Chubb, J.J. Nemecek, and D.E. Simmons, "An Experimental Study of the CO₂-CH₄ Reforming-Methanation Cycle as a Mechanism for Converting and Transporting Solar Energy," *Solar Energy* 29, 141 (1982).

11. T.A. Chubb, J.J. Nemecek, D.E. Simmons, J.H. McCrary, and Gloria E. McCrary, "Thermochemical Receiver Tests," *Proceedings, 1981 Annual Meeting, American Section, International Solar Energy Society, Inc. Vol 4.1*, 166 (1981).

Due to the fact that project funding was running low at this time, every effort was made to minimize spending in the construction and operation of the closed-loop test facility. Virtually all of the hardware comprising the loop were taken from the reforming and SO_3 test facilities described earlier. The most difficult item to procure was the blower. After a lengthy search, a \$300 blower manufactured by a milking machine company was acquired and found to be technically adequate for short-term operations.

A total of sixteen test runs were made in the closed-loop facility. The first such run (Run 80) used a start-up (make-up) gas comprised of 77.5% H_2 , 21.1% CO , and 1.4% CO_2 (volume percent). During this 2.75 hour test, the mass flow slowly dropped from 0.5 g/s to 0.1 g/s. The methane concentration in the reformer feedstock line was high (>40%) and the CO concentration in the synthesis gas line ran from 12 to 20% during most of the run. The $[\text{CO}]$ in the feedstock line ran <1%. Approximately 500 watts of power was delivered to the methanation furnace. The test was terminated due to blower failure. Runs 81 and 82 were hampered by blower and catalyst problems.

On May 18, 1981 Run 83 was conducted with the same start-up gas composition as used in Runs 80-82. Figures 2-13 contain plots of the results from this test. The test was terminated after eight hours due to carbon build-up in the lines and on the mass-flow transducer. Except for the first and last hours of Run 83 the pressures, pressure drops, mass flow, feedstock and synthesis gas composition, and all temperatures exhibited very stable operation as power was delivered to the methanation reactor furnace. This demonstration of closed-loop operation was considered to be a success in spite of carbon build-up problems. After start-up in all of these runs the methanation furnace heaters were removed and methanator cooling was achieved by blowing compressed air through the furnace cavity.

Runs 84 and 85 utilized a slight increase in the hydrogen concentration of the start-up gas in an effort to decrease carbon deposits. The results from these runs were little different from Run 83 with line carbonization still a problem.

In August, September, and October 1981, Runs 86 through 96 were conducted with a start-up synthesis gas mixture of 80% H₂ and 20% CO₂. With the reformer operating at 900°C and the methanator at 550 to 600°C the equilibrium feedstock and synthesis gas compositions should be as follows:

	Feedstock	Synthesis Gas
H ₂	38.4%(vol.)	62.8% (vol.)
H ₂ O	35.2	17.1
CO	3.2	16.6
CO ₂	7.2	3.3
CH ₄	16.0	0.3

These numbers were calculated assuming 50% CO₂ reforming and 50% steam reforming at 4 atmospheres pressure.

During the course of the eleven runs made under these conditions, a total of 41 operating hours was put on the closed-loop system. The system generally performed well. There were some carbon fouling incidents, and considerable difficulty was experienced with the blower. Run 91 was typical of this series and graphs of its results are shown in Figures 14 through 25. The equilibrium values of the gas concentrations which were measured are consistent with those predicted above. Clearly, it would be desirable to measure the concentration of all constituents, but instrumentation for this purpose was not available.

It is believed that the carbon problem can be eliminated through the optimization of catalyst, catalyst configuration, pressure, temperatures, and gas composition. If this is not possible, the carbon

problem can be minimized and coped with by proper mechanical and chemical engineering design.

V. CONCLUSIONS

The work reported here has clearly demonstrated not only the feasibility but the practicality of the chemical conversion and transport of solar energy. The present field model Solchem receiver is capable of operating at the focus of a 6m paraboloidal collector with an efficiency of 60-65%. This receiver efficiency could be increased to perhaps 85% by improving the cavity design. If the spacing of receiver elements in the cavity were optimized, the difference between the temperatures of the front and back converter coils could be reduced from 350C^o (Run 74) to less than 100C^o. With all six coils operating in the 850-950C^o temperature range and with 2 g/s of gas flowing through each, results show that the improved cavity receiver would be converting about 20kW of solar power. A major cause of energy loss was reflection of light from the back surface of the cavity out of the entrance aperture. Addition of a special receiver element designed to cover this surface would largely eliminate this source of energy loss. Finally, receiver heat losses could be reduced through the use of more efficient thermal insulation and through use of a concave cone shaped entrance window. Such an entrance cone would reduce both convective and radiative aperture losses.

Nickel catalyst deterioration was a serious problem early in the project. This problem, however, appears to have been resolved by the use of a ruthenium-on-stainless-steel catalyst. During hundreds of hours of operation of ruthenium catalyzed reformers no effects due to

catalyst degradation have been observed. Side reactions have presented minor problems. The shift reaction leads to the formation of small quantities of steam which are controlled by the steam reforming reaction and by allowing line temperatures to operate above their respective dew points.

A major problem area in closed-loop operation was found to be carbon deposition. It is strongly felt, however, that this problem can either be eliminated or tolerated through the optimization of chemical and mechanical design.

FIGURE 1.

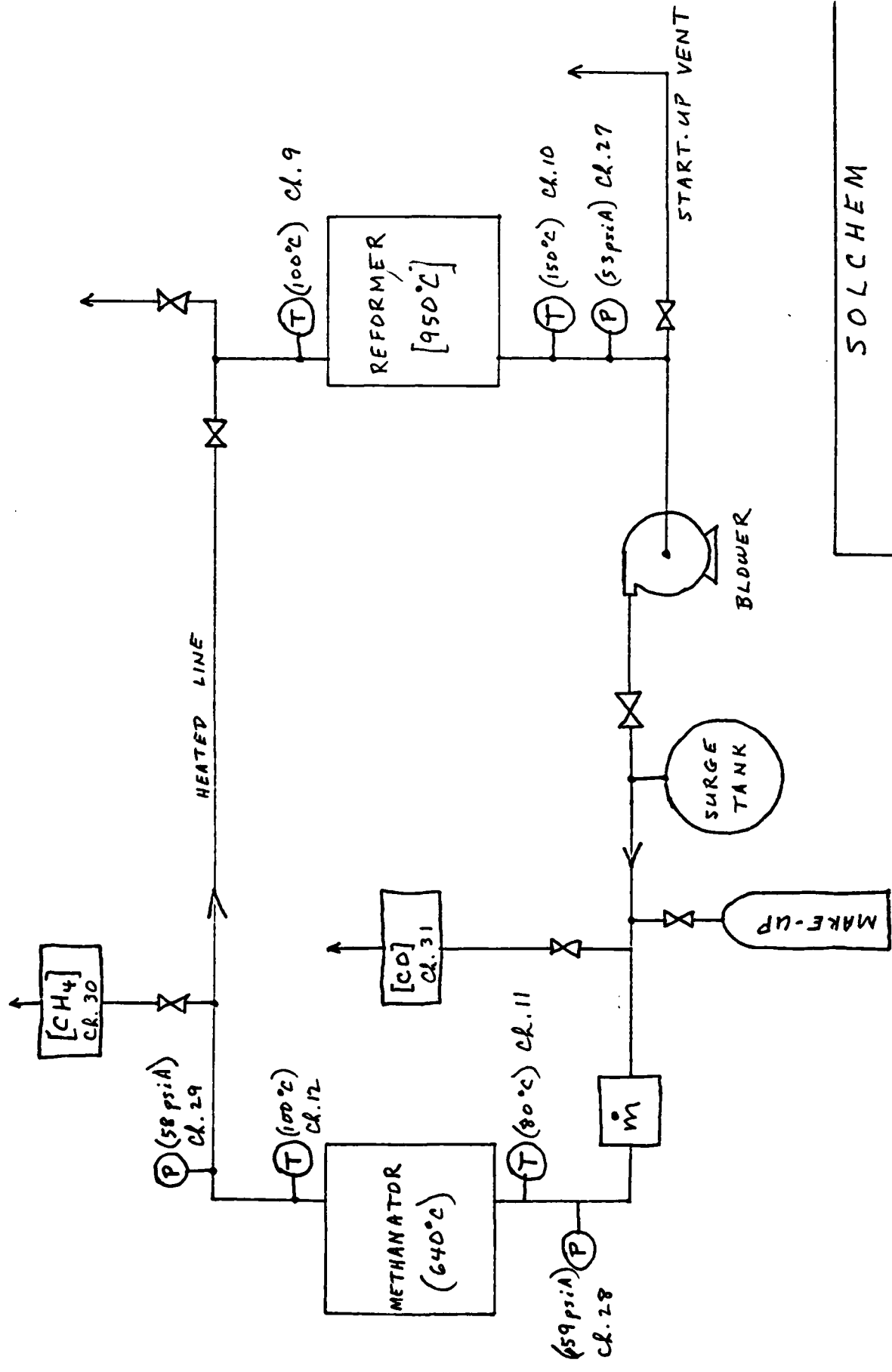

SOLCHEM
LABORATORY CLOSED LOOP
5/21/81
WJF

FIGURE 2.

May 18, 1981

Run No. 83

Closed Loop

Solgas 0.6

SOLCHEM PRESSURE SET
PRESSURE IN +

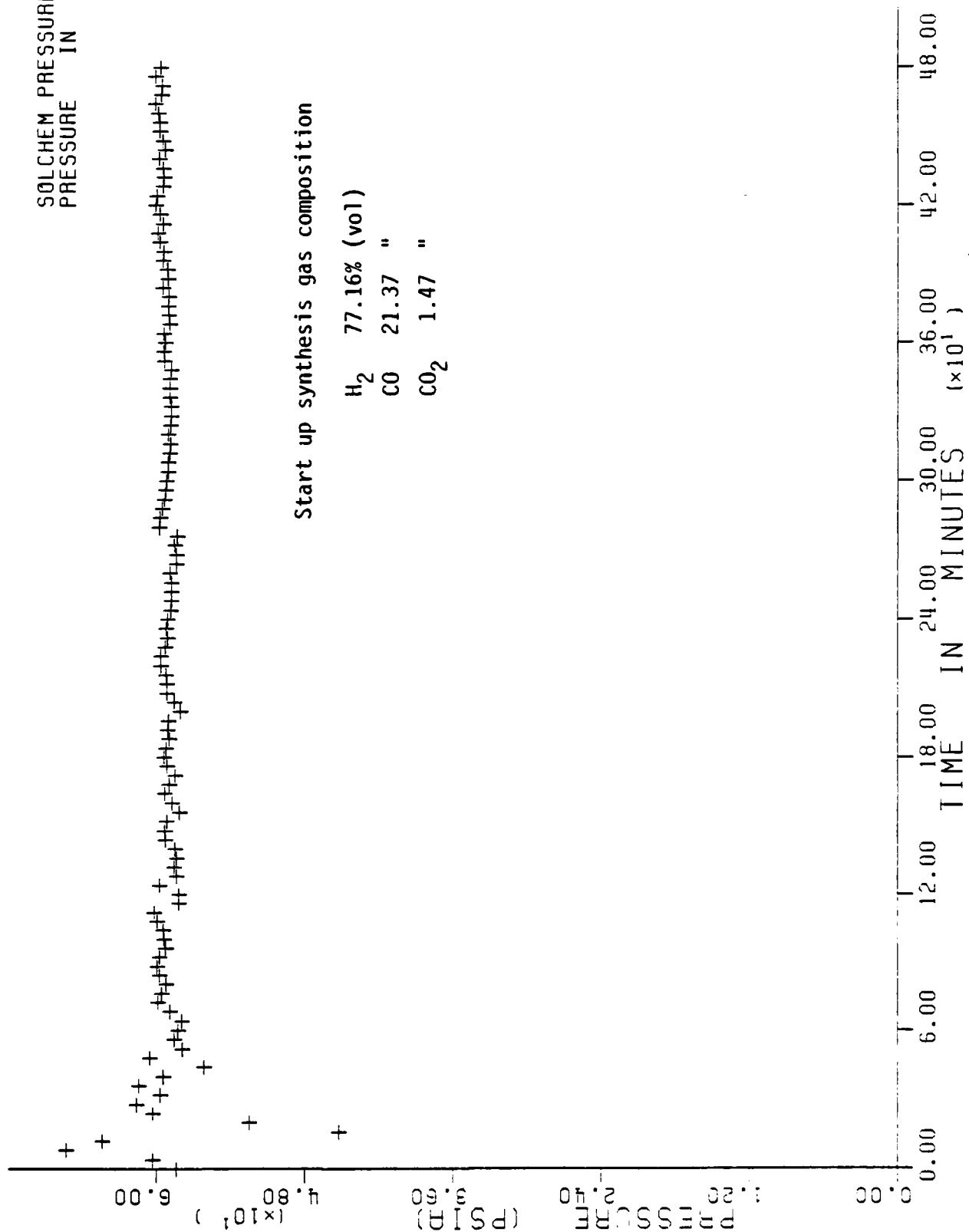

Start up synthesis gas composition

H₂ 77.16% (vol)
CO 21.37 "
CO₂ 1.47 "

FIGURE 3.

May 18, 1981

Run No. 83

Closed Loop

Solgas 0.6

SOLCHEM PRESSURE SET
PRES IN - PRES OUT +

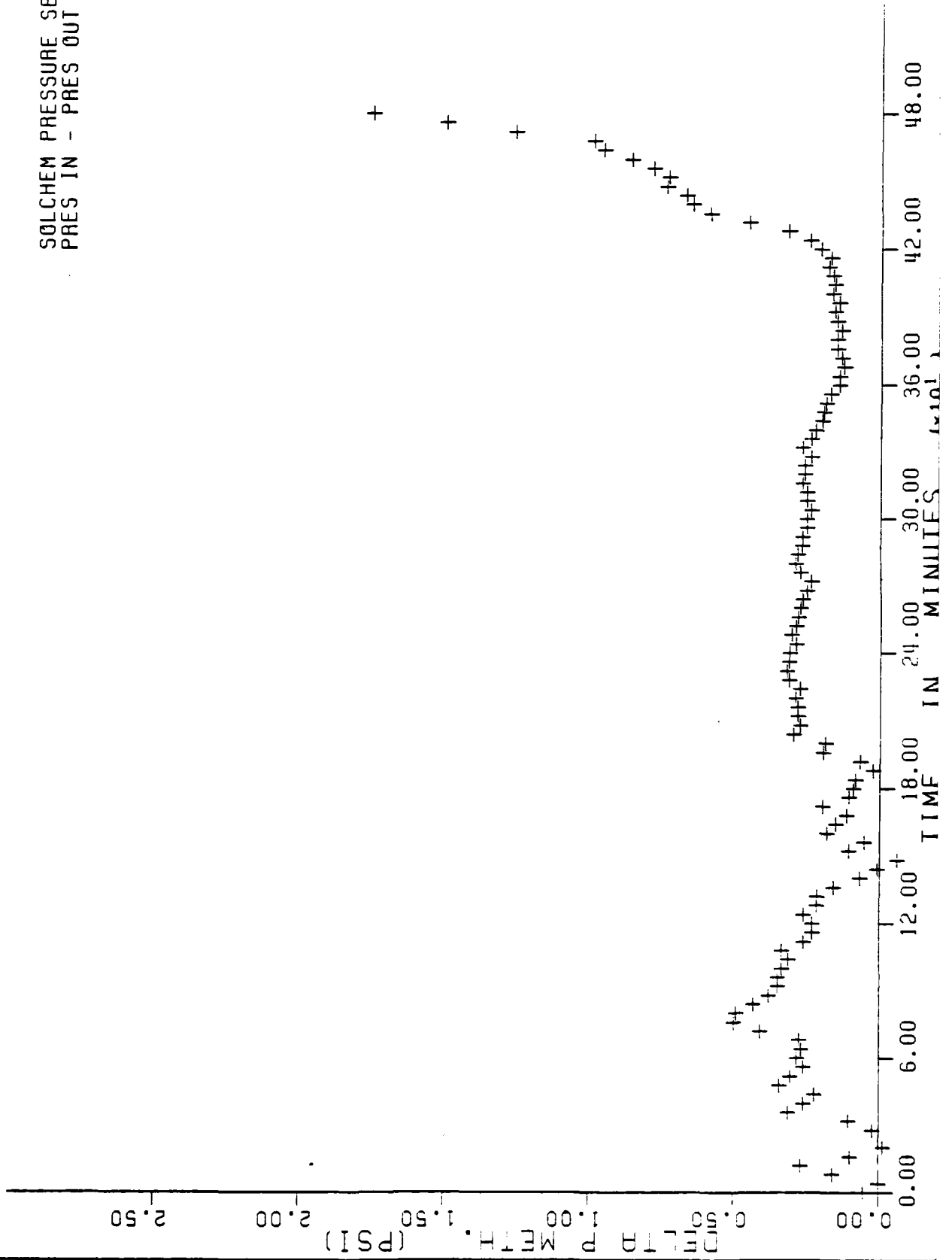

FIGURE 4.

May 18, 1981

Run No. 83

Closed Loop

Solgas 0.6

SOLCHEM PRESSURE SET
PRES IN - PRES OUT +

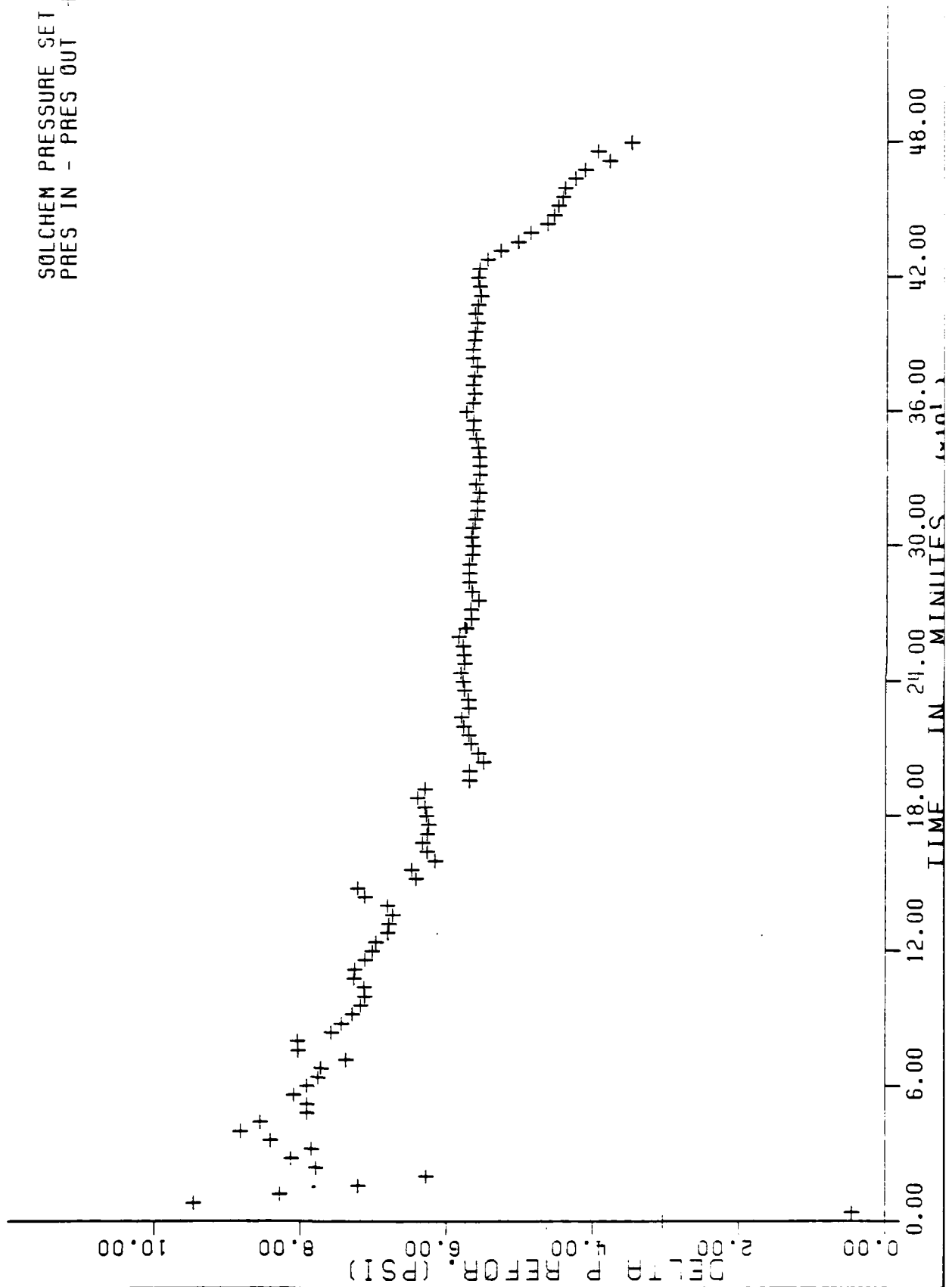

FIGURE 5.

Solgas 0.6

Closed Loop

Run No. 83

May 18, 1981

SOLCHEM MASSFLOW SET
MASS FLOW +

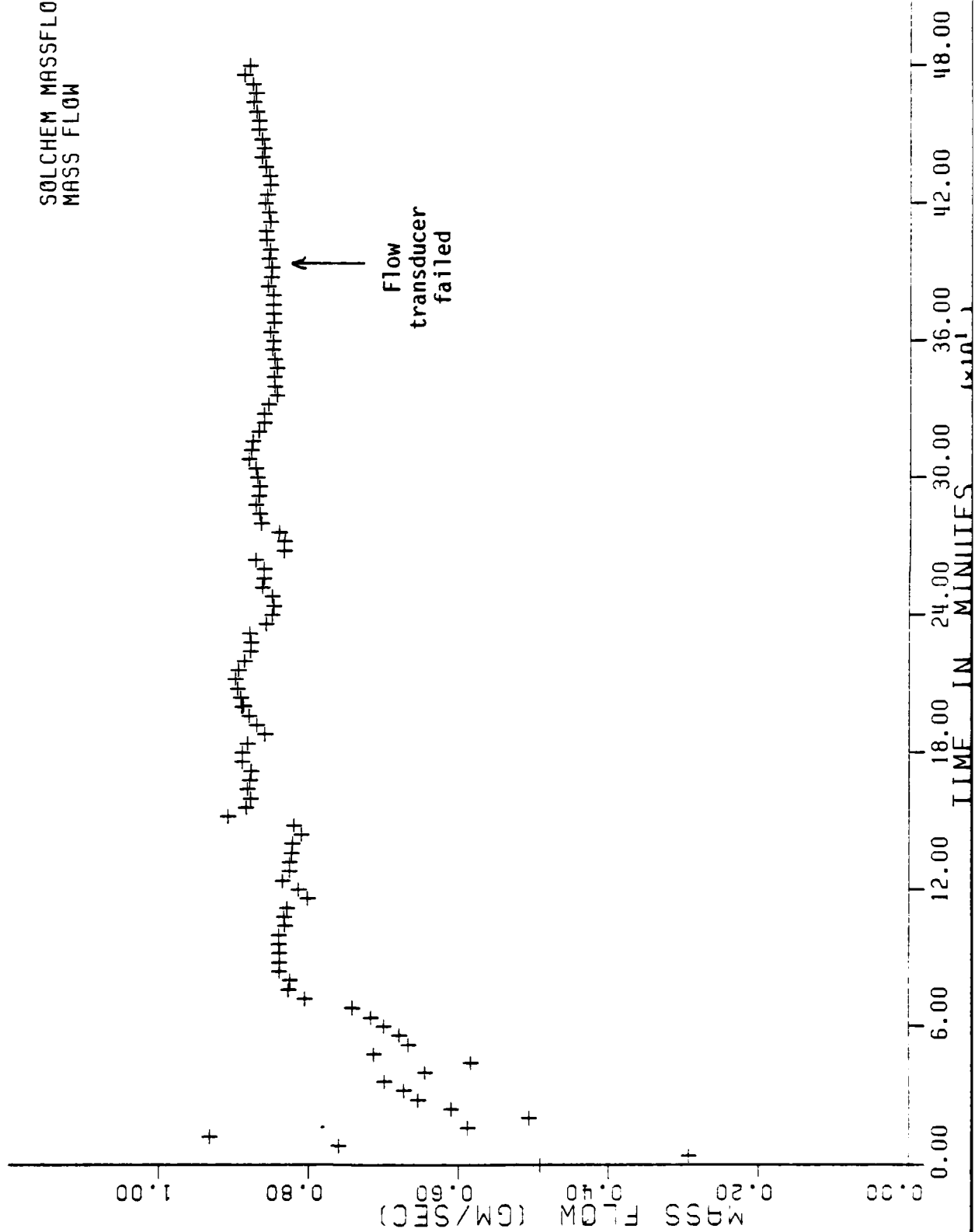

FIGURE 6.

May 18, 1981

Run No. 83

Closed Loop

Solgas 0.6

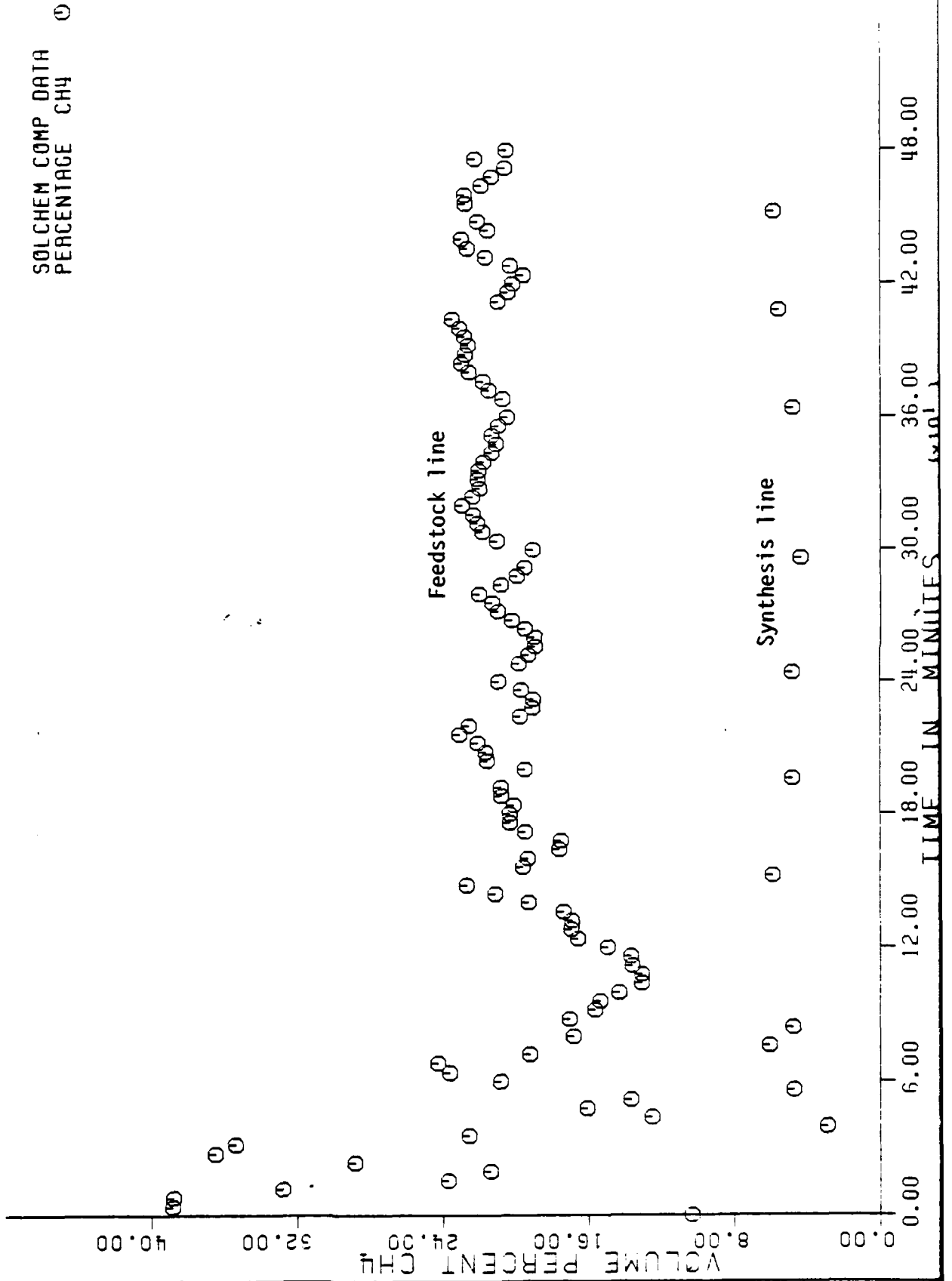

FIGURE 7.

SoIgas 0.6

Closed Loop

Run No. 83

May 18, 1981

SOLCHEM COMP DATA
PERCENTAGE CO +

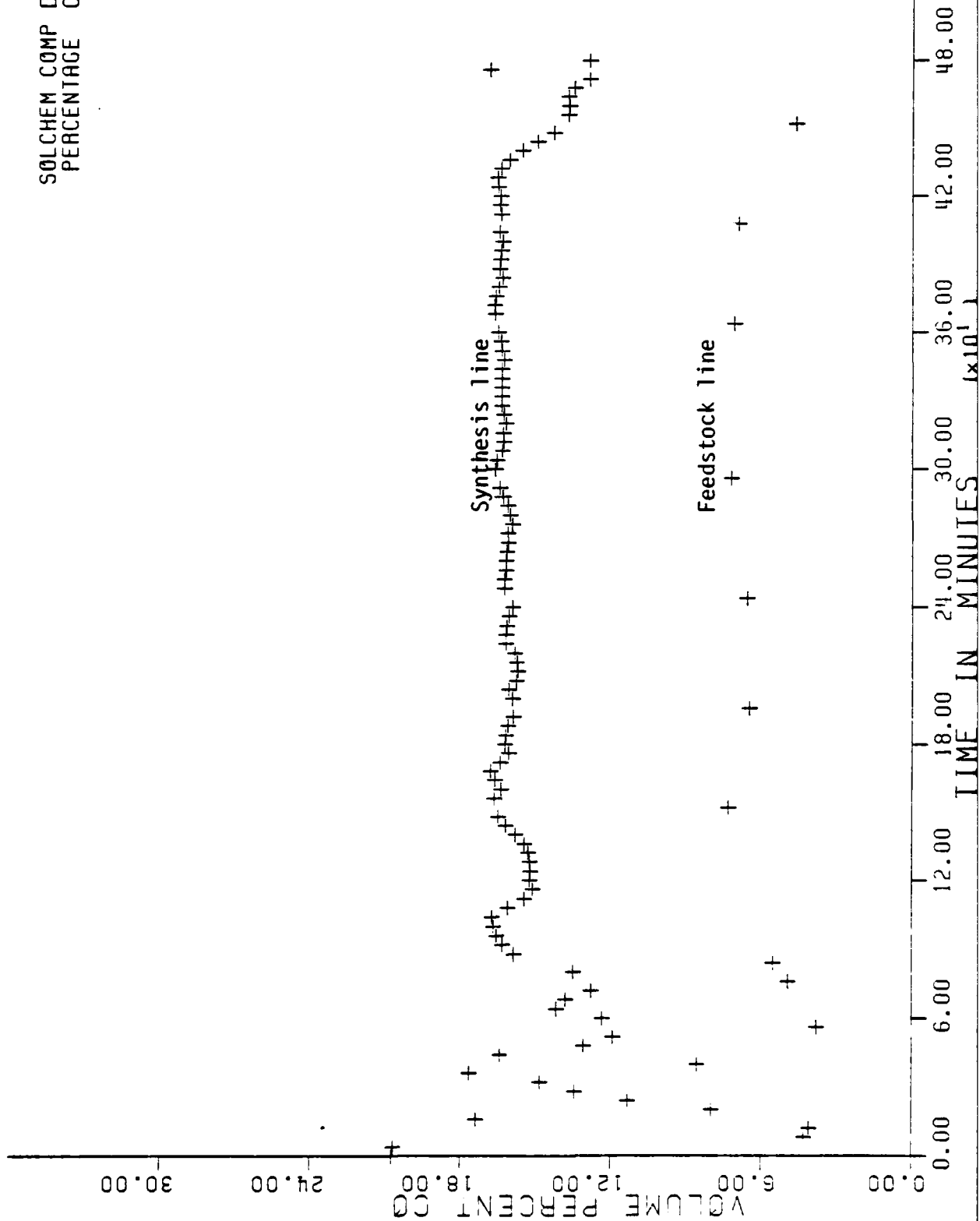

FIGURE 8.

May 18, 1981

Run No. 83

Closed Loop

So1gas 0.6

THERMOCOUPLE GRAPHS
THERMOCOUPLE 1 +
THERMOCOUPLE 2 X
Reformer Converter

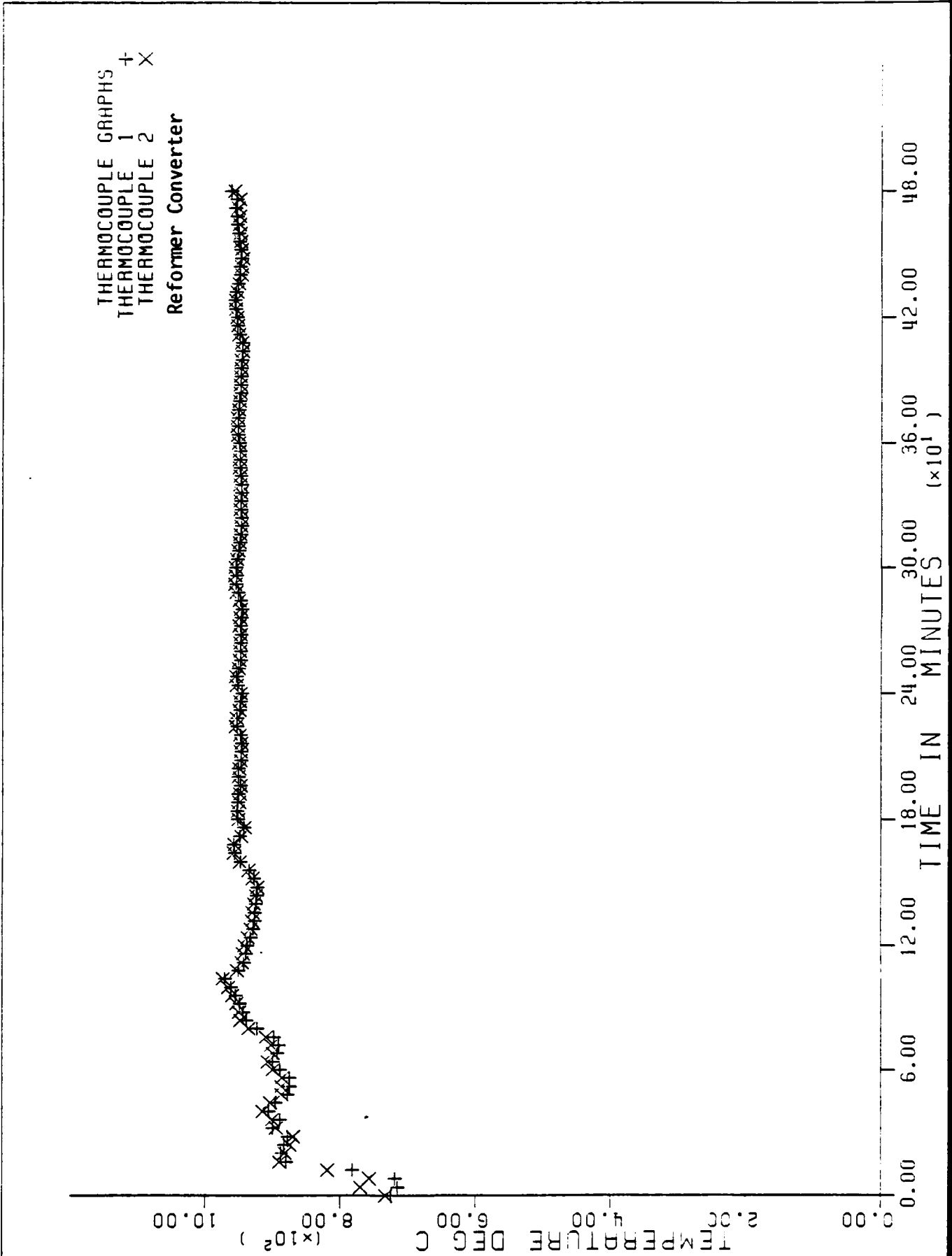

FIGURE 9.

May 18, 1981 Run No. 83 Closed Loop Solgas 0.6

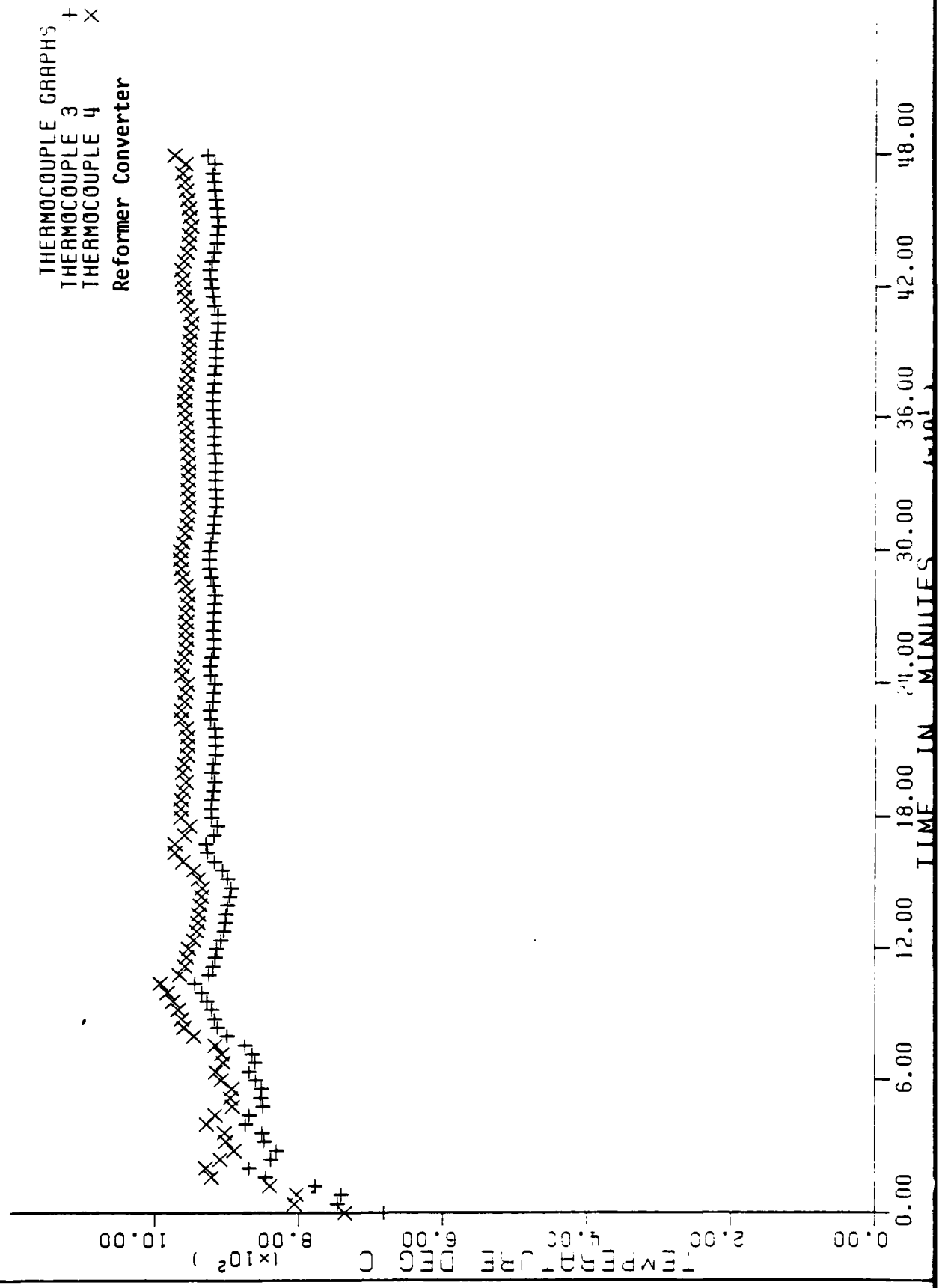

FIGURE 10.

May 18, 1981 Run No. 83 Closed Loop Solgas 0.6

THERMOCOUPLE GRAPHS
THERMOCOUPLE 5 X
THERMOCOUPLE 6 O
Methanator Converter

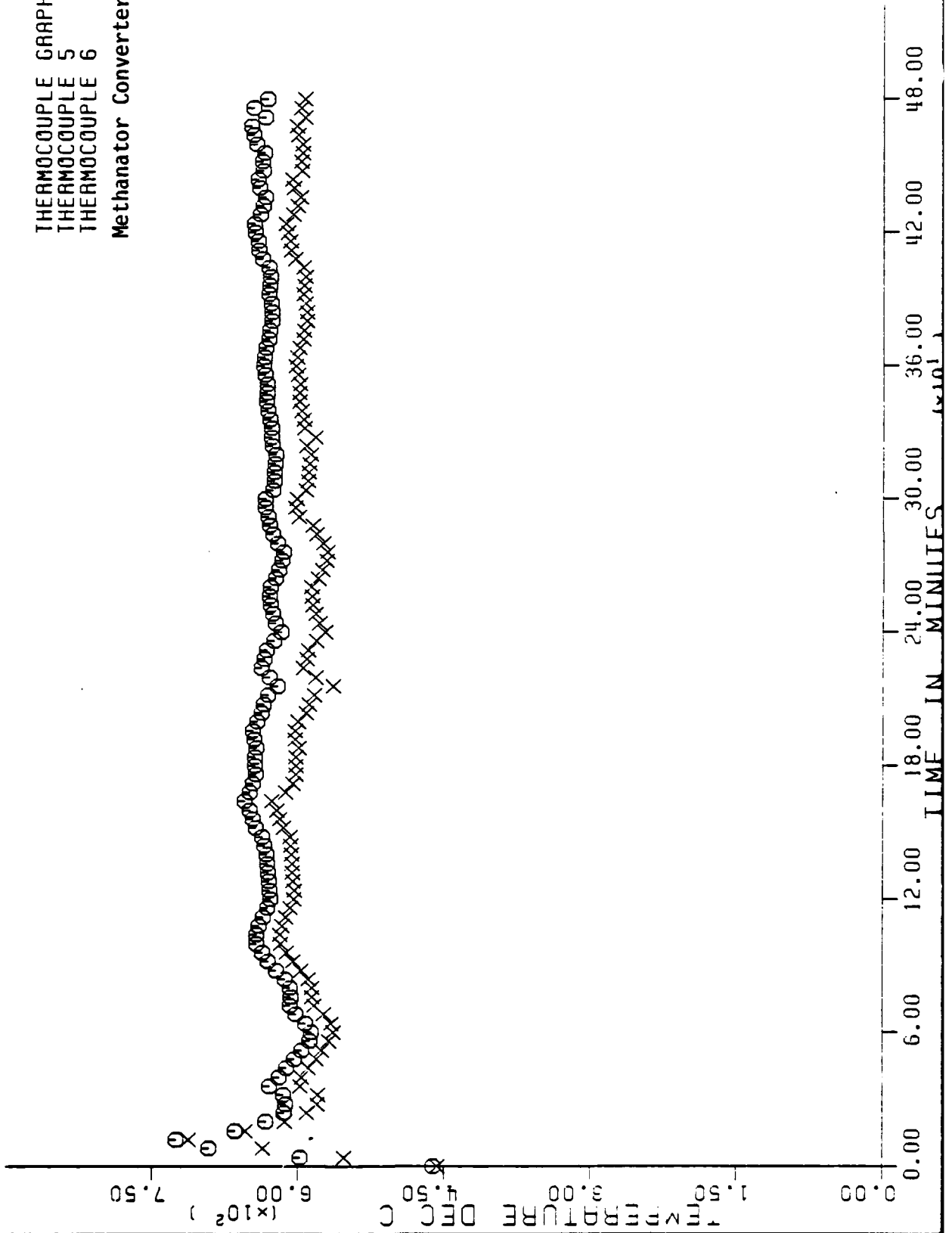

FIGURE 11.

May 18, 1981

Run No. 83

Closed Loop

Solgas 0.6

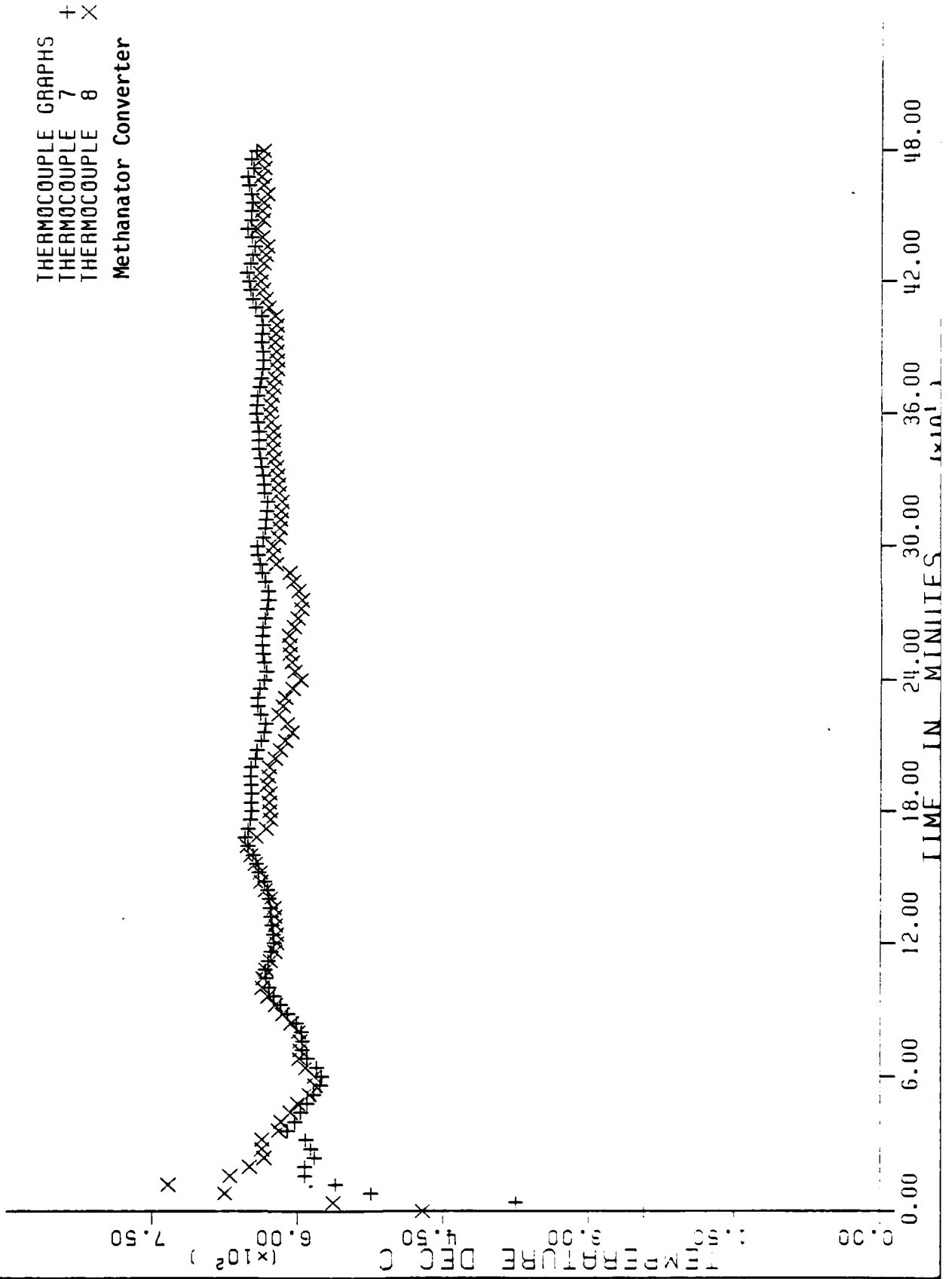

FIGURE 12.

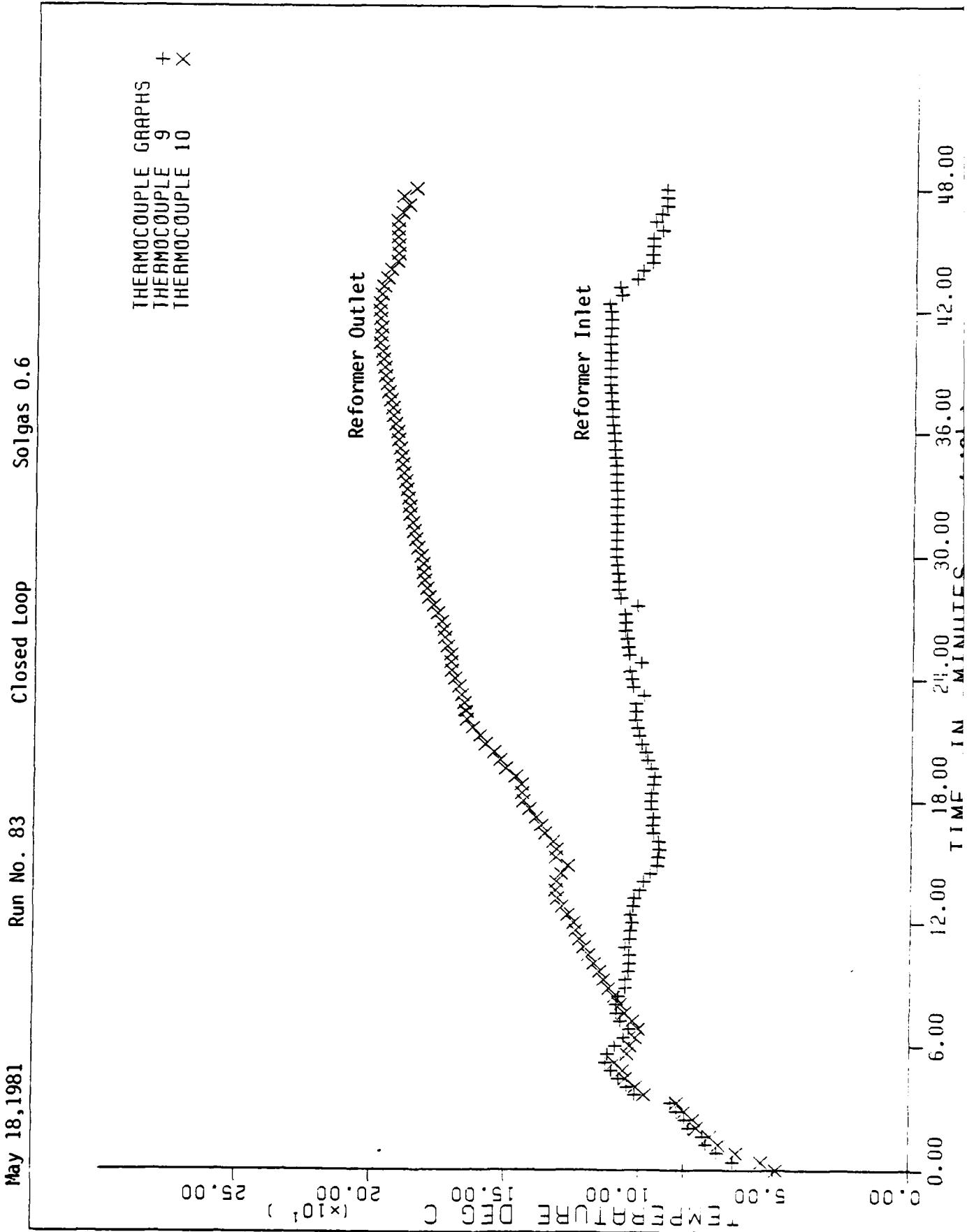

FIGURE 13.

May 18, 1981

Run No. 83

Closed Loop

Solgas 0.6

THERMOCOUPLE GRAPHS
THERMOCOUPLE 11 +
THERMOCOUPLE 12 X

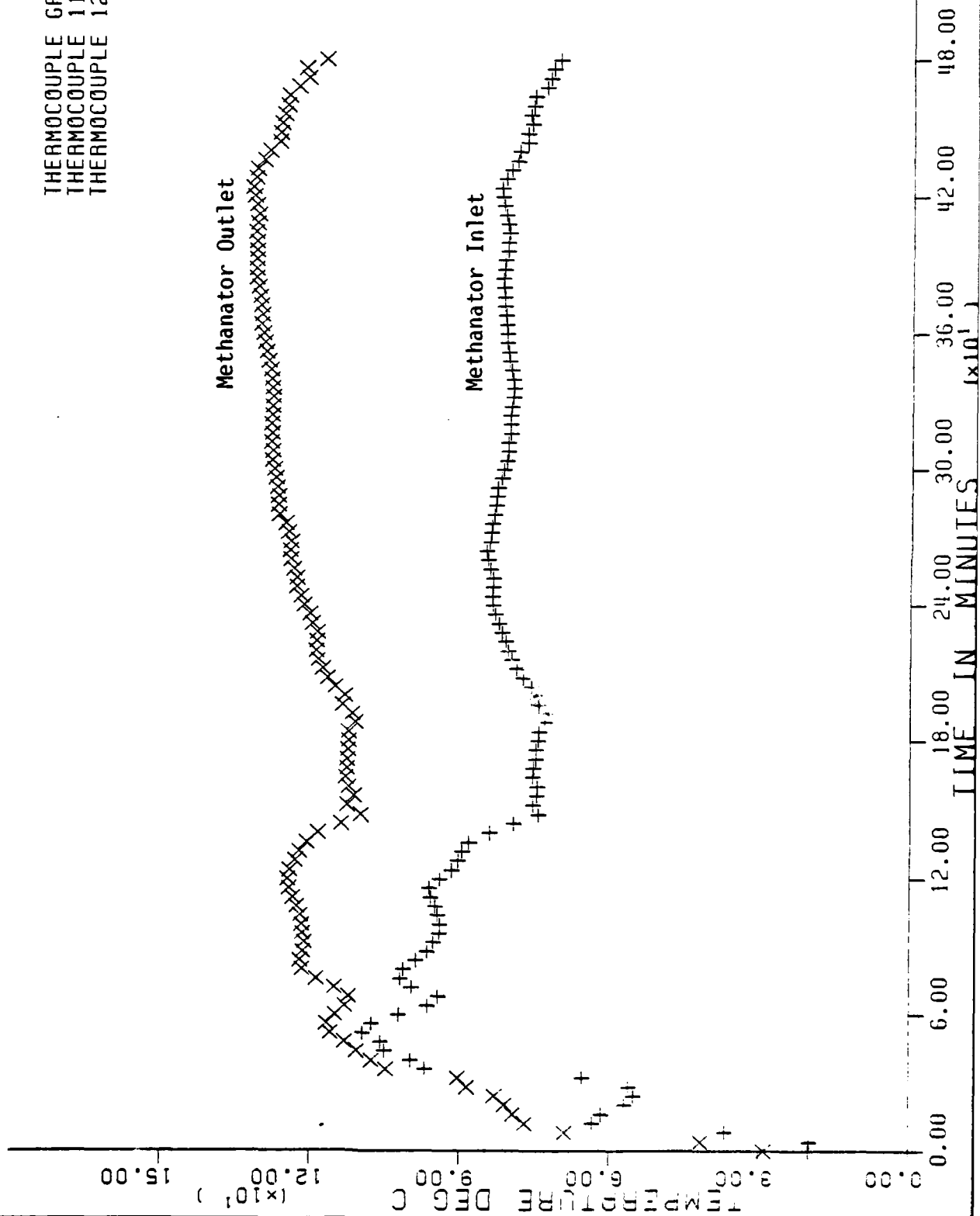

FIGURE 14.

Sept. 18, 1981 Run No 91 Closed Loop

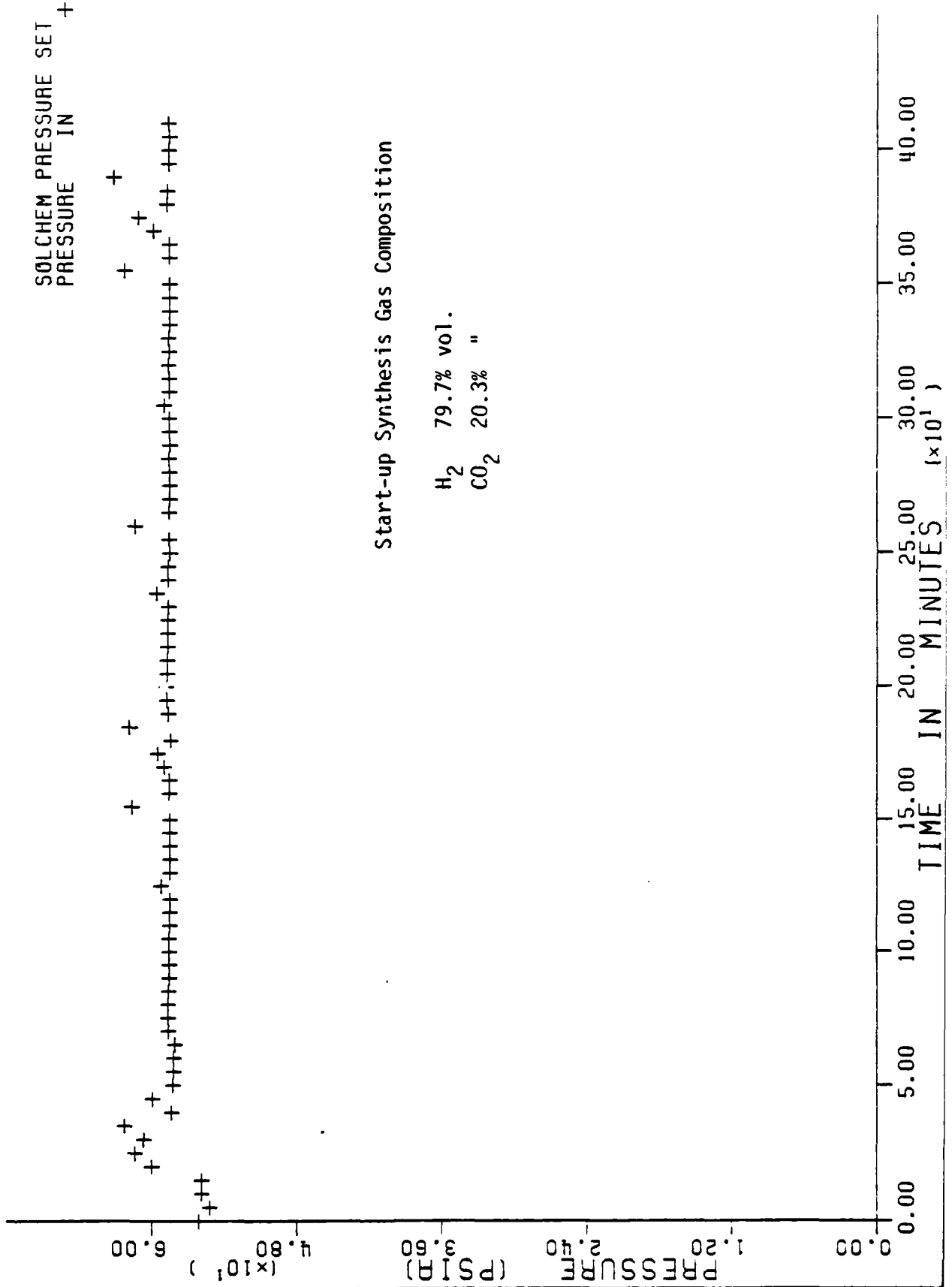

FIGURE 15.

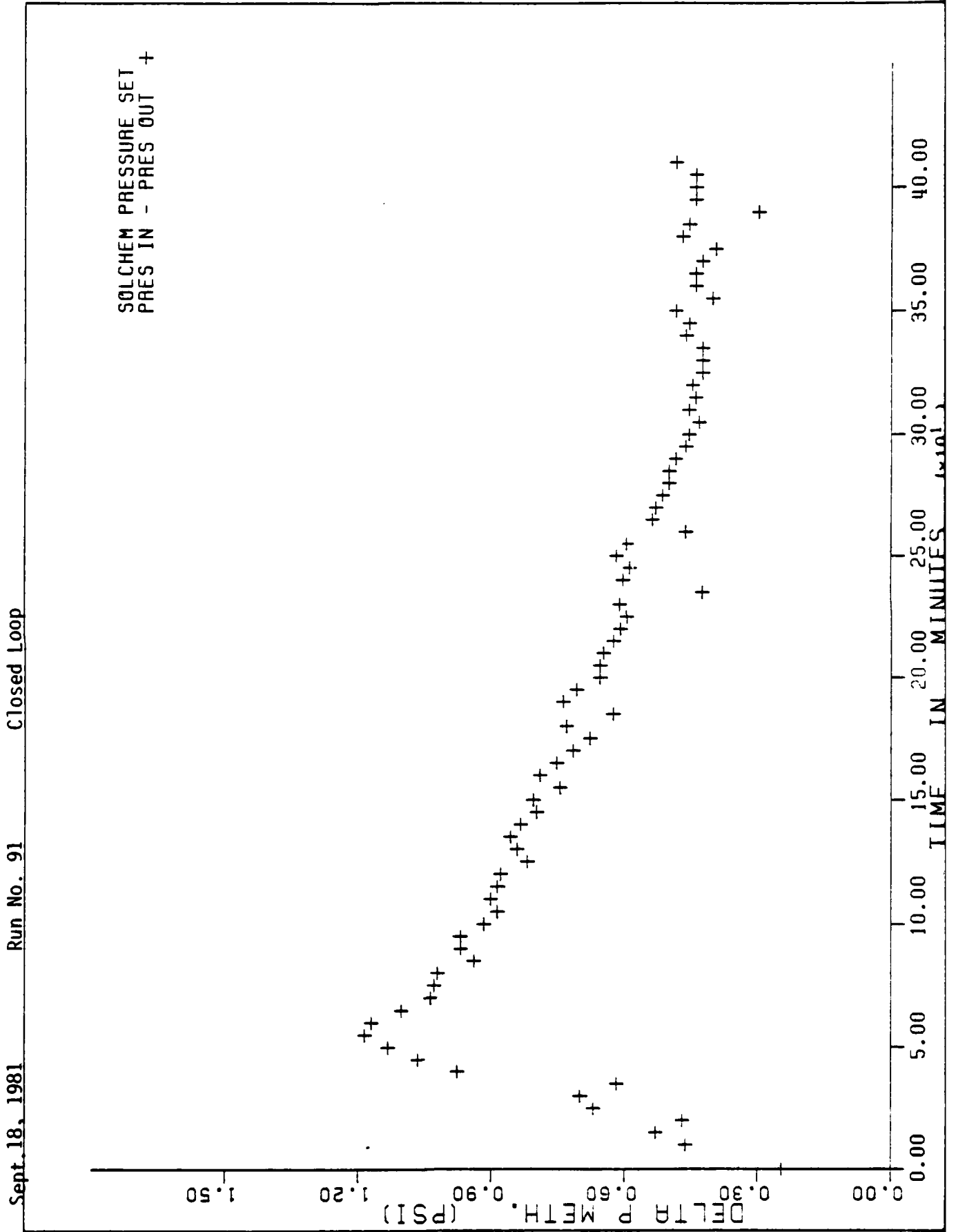

FIGURE 16.

Sept. 18, 1981

Run No. 91

Closed Loop

SOLCHEM PRESSURE SET
PRES IN - PRES OUT +

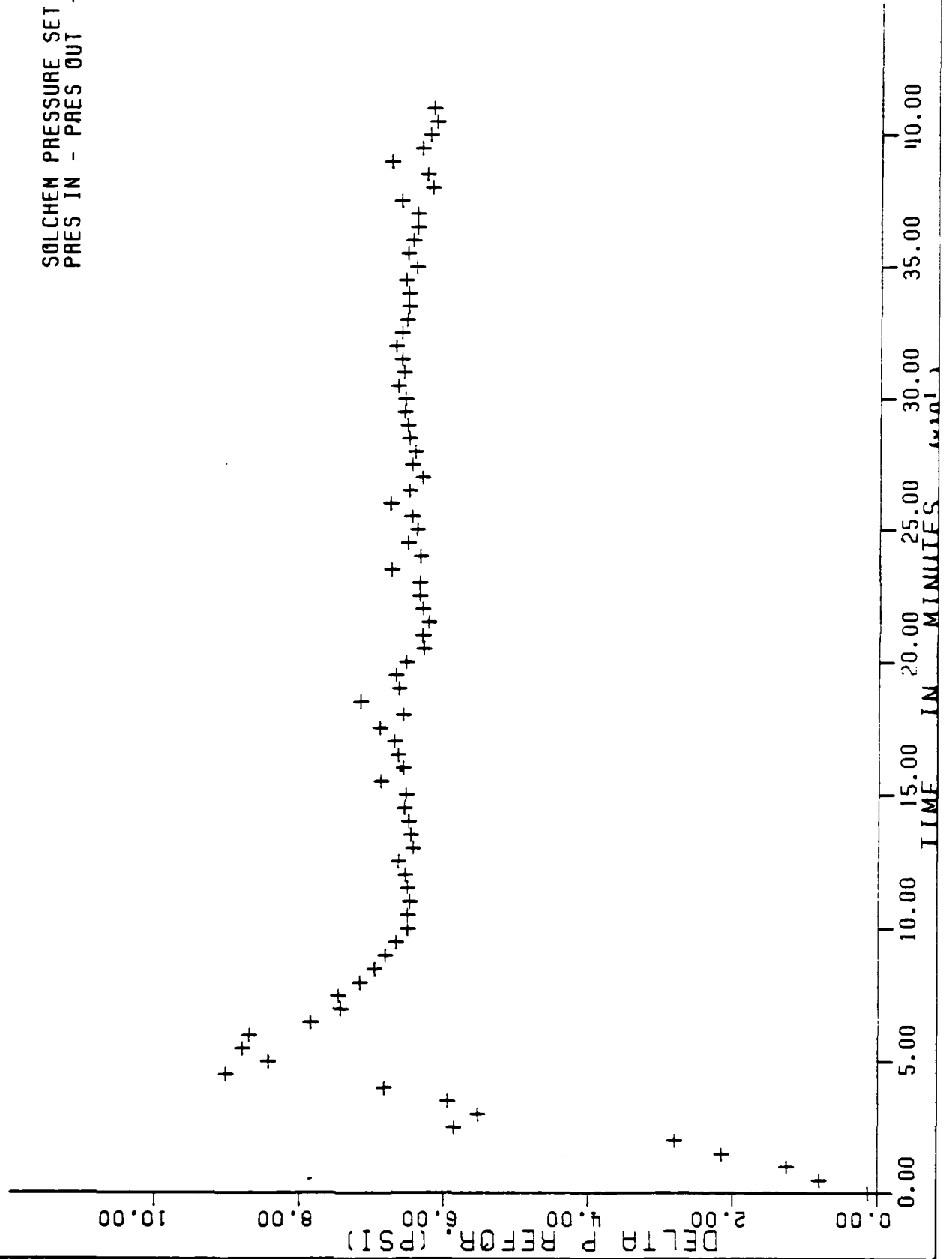

FIGURE 17.

Sept. 18, 1981

Run No. 91

Closed Loop

SOLCHEM MASSFLOW SET
MASS FLOW +

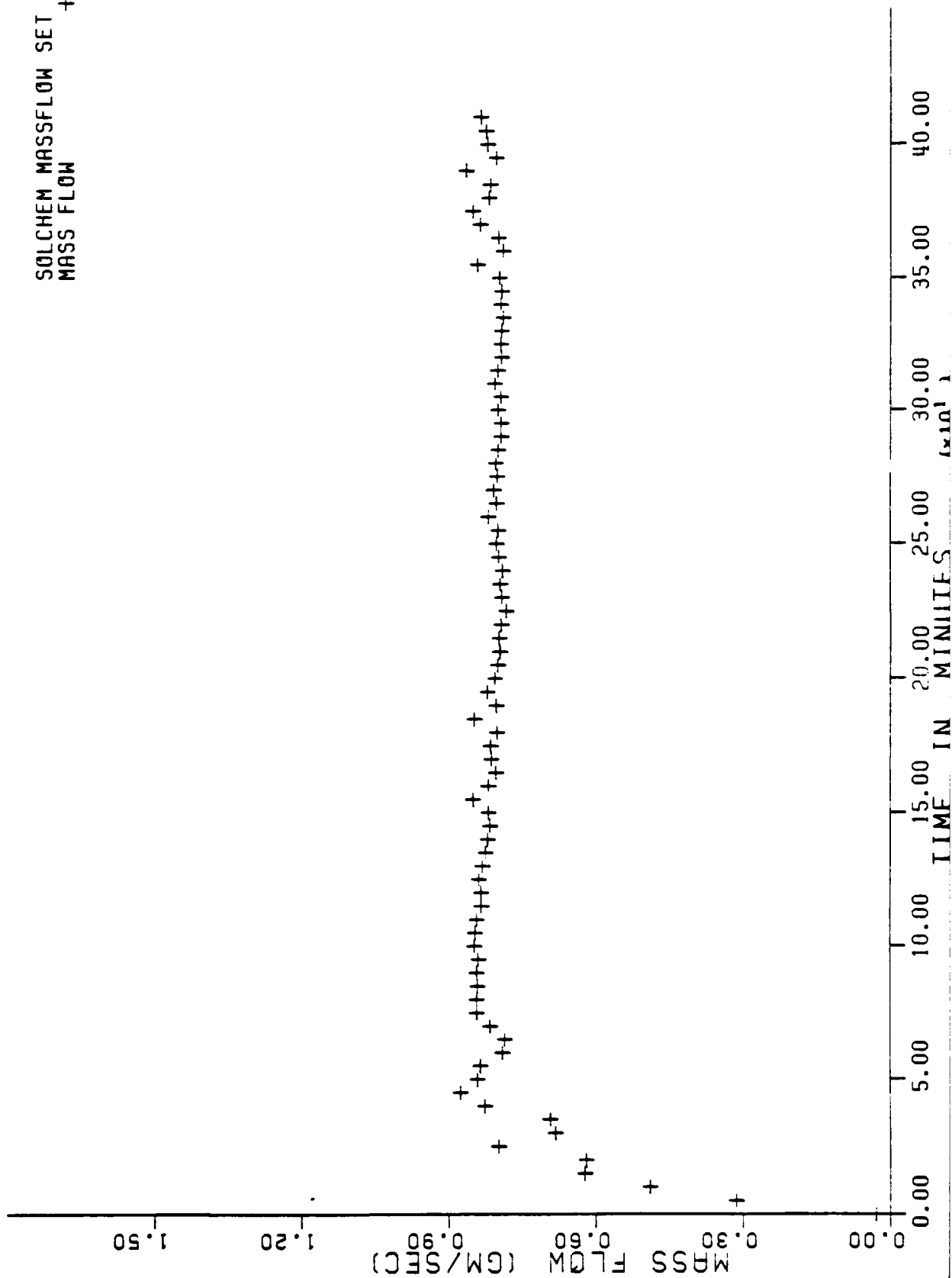

FIGURE 18.

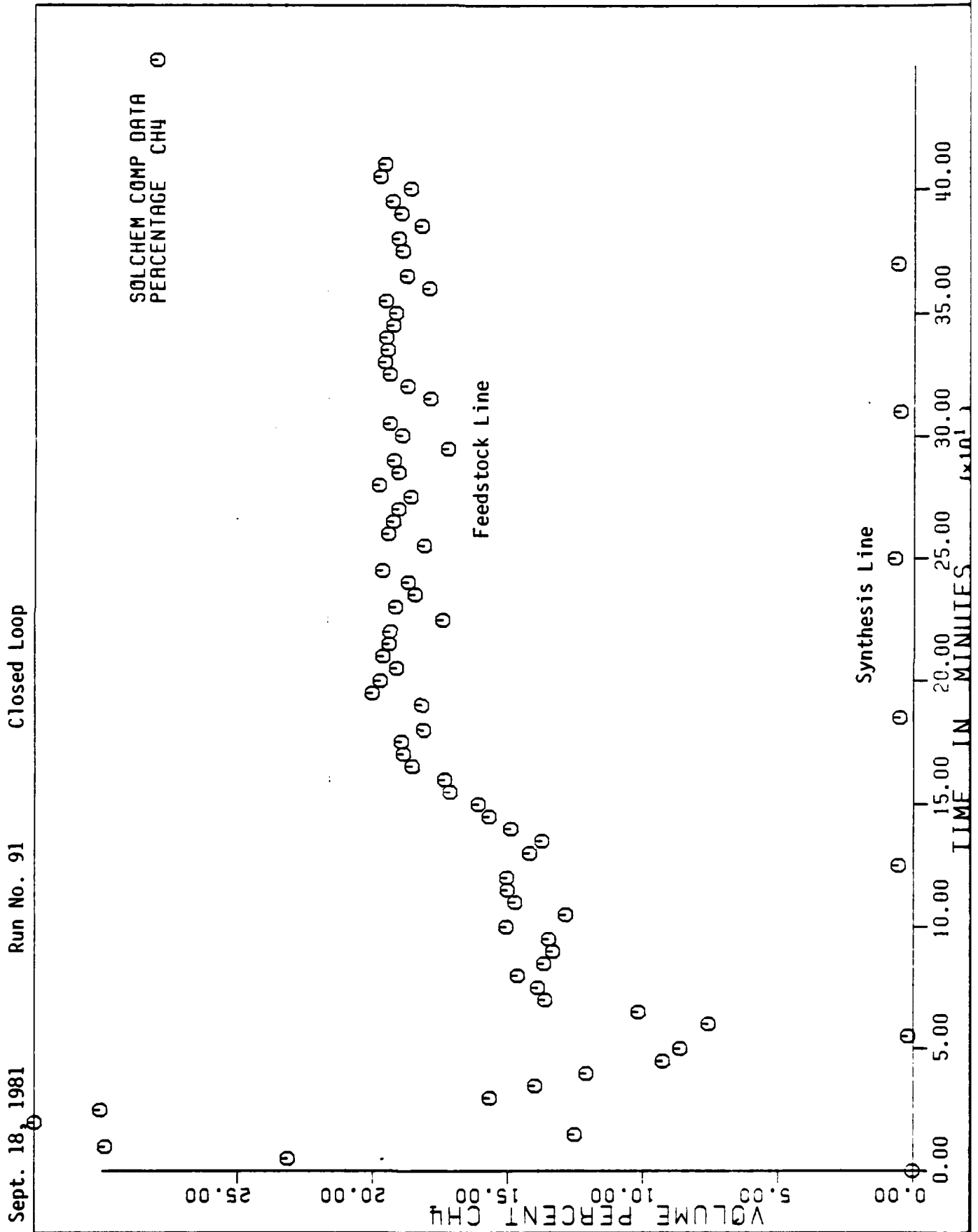

FIGURE 19.

Sept. 18, 1981 Run No. 91 Closed Loop

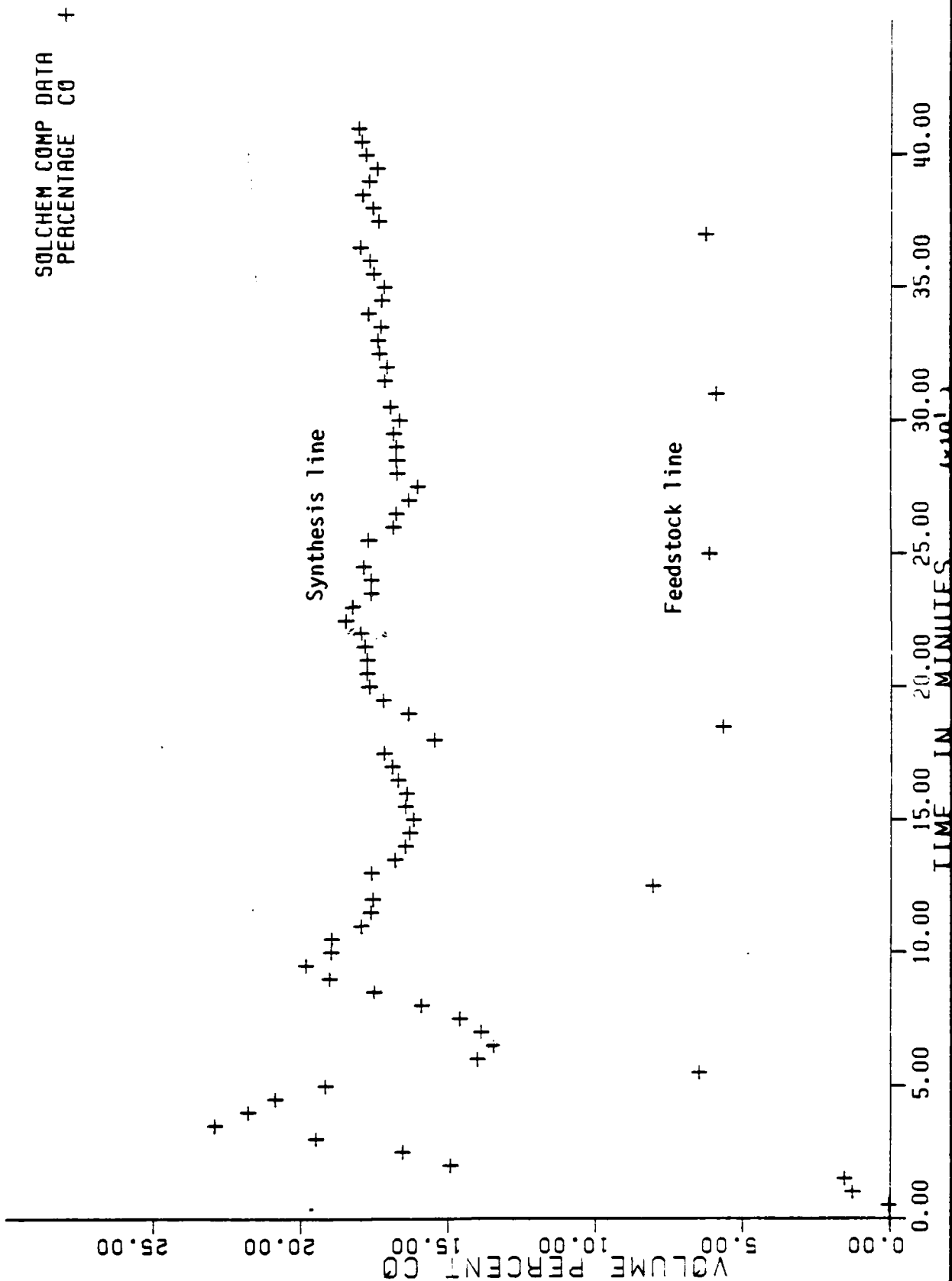

FIGURE 20.

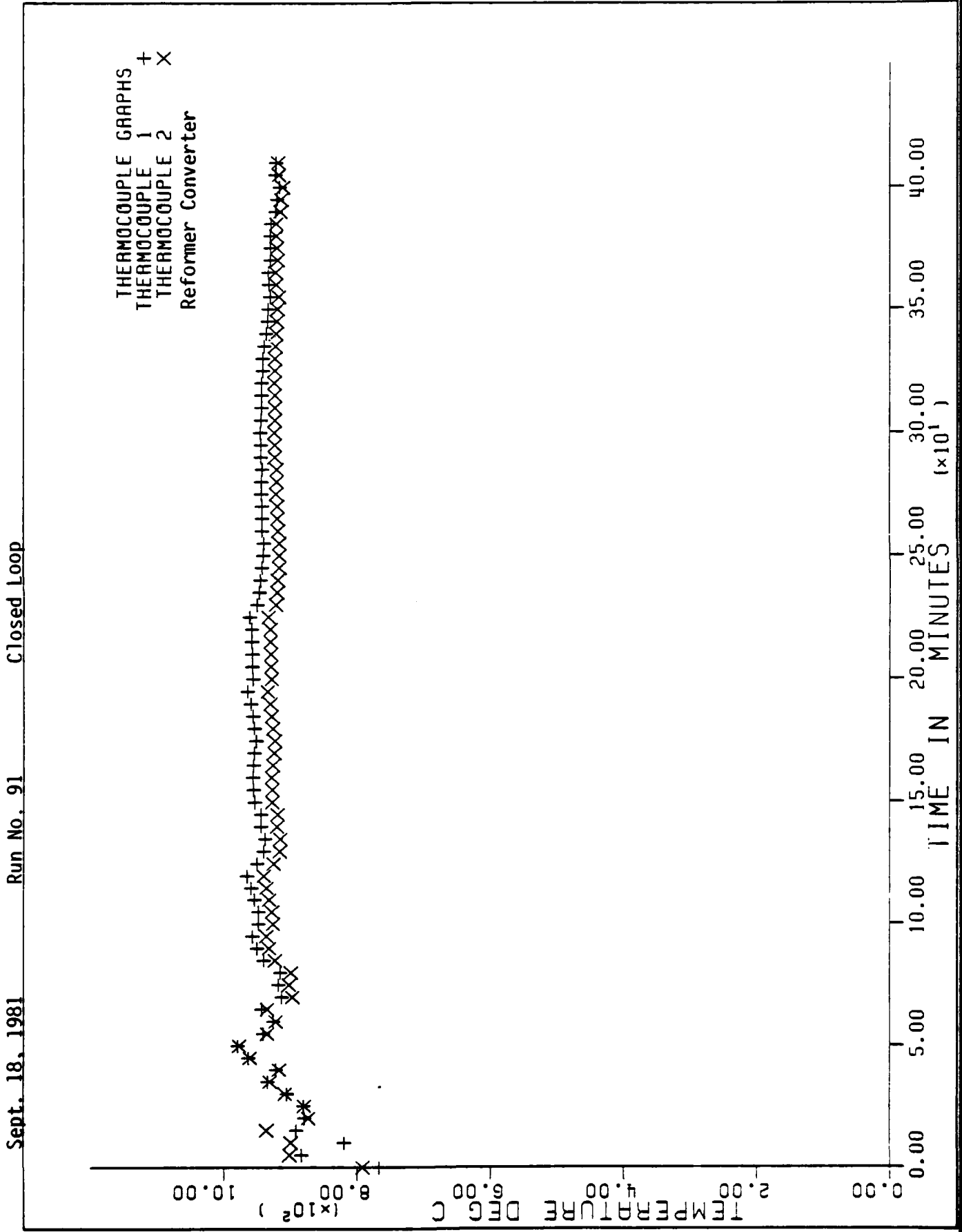

FIGURE 21.

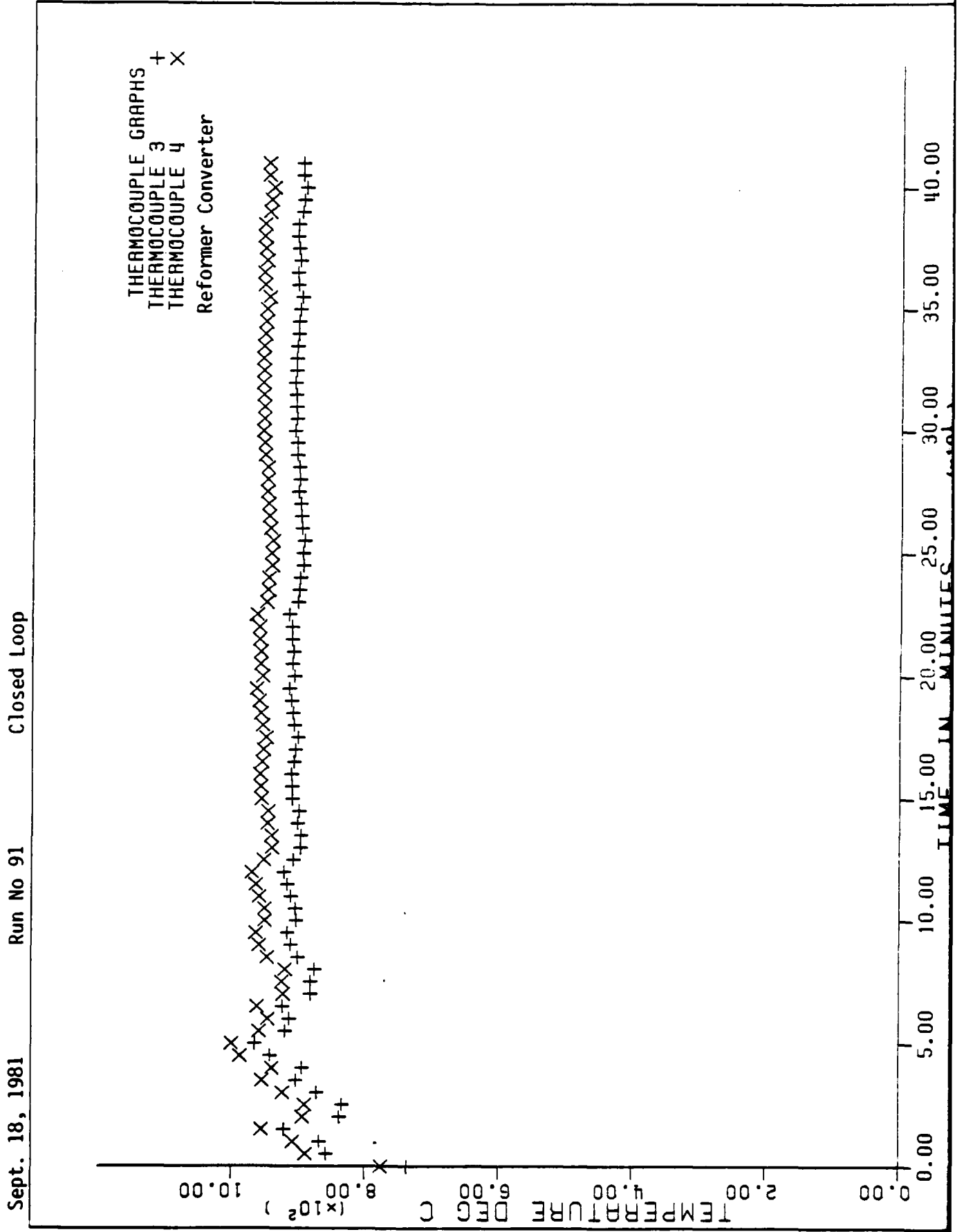

FIGURE 22.

Sept. 18, 1981

Run No. 91

Closed Loop

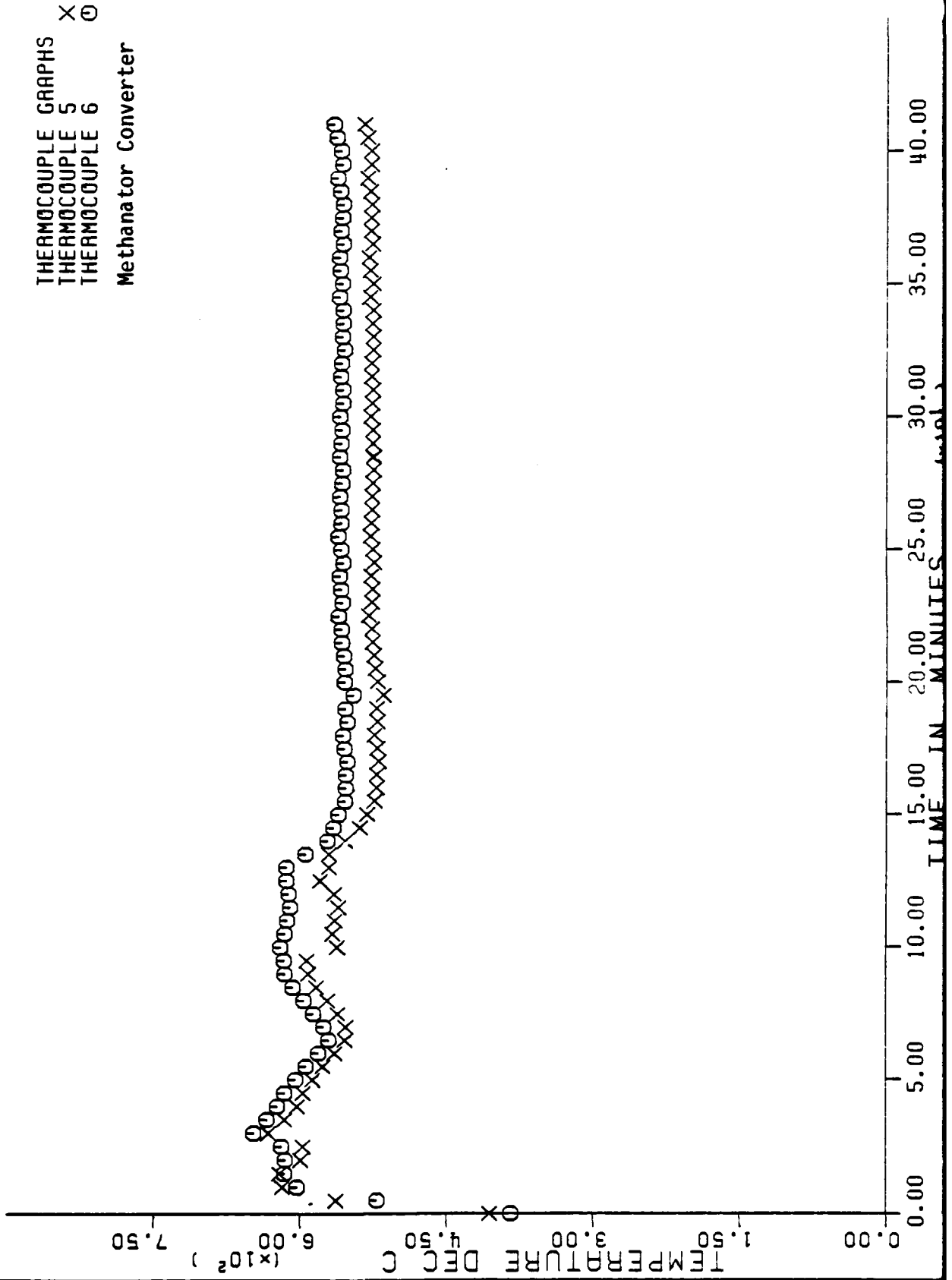

FIGURE 23.

Sept. 18, 1981

Run No. 91

Closed Loop

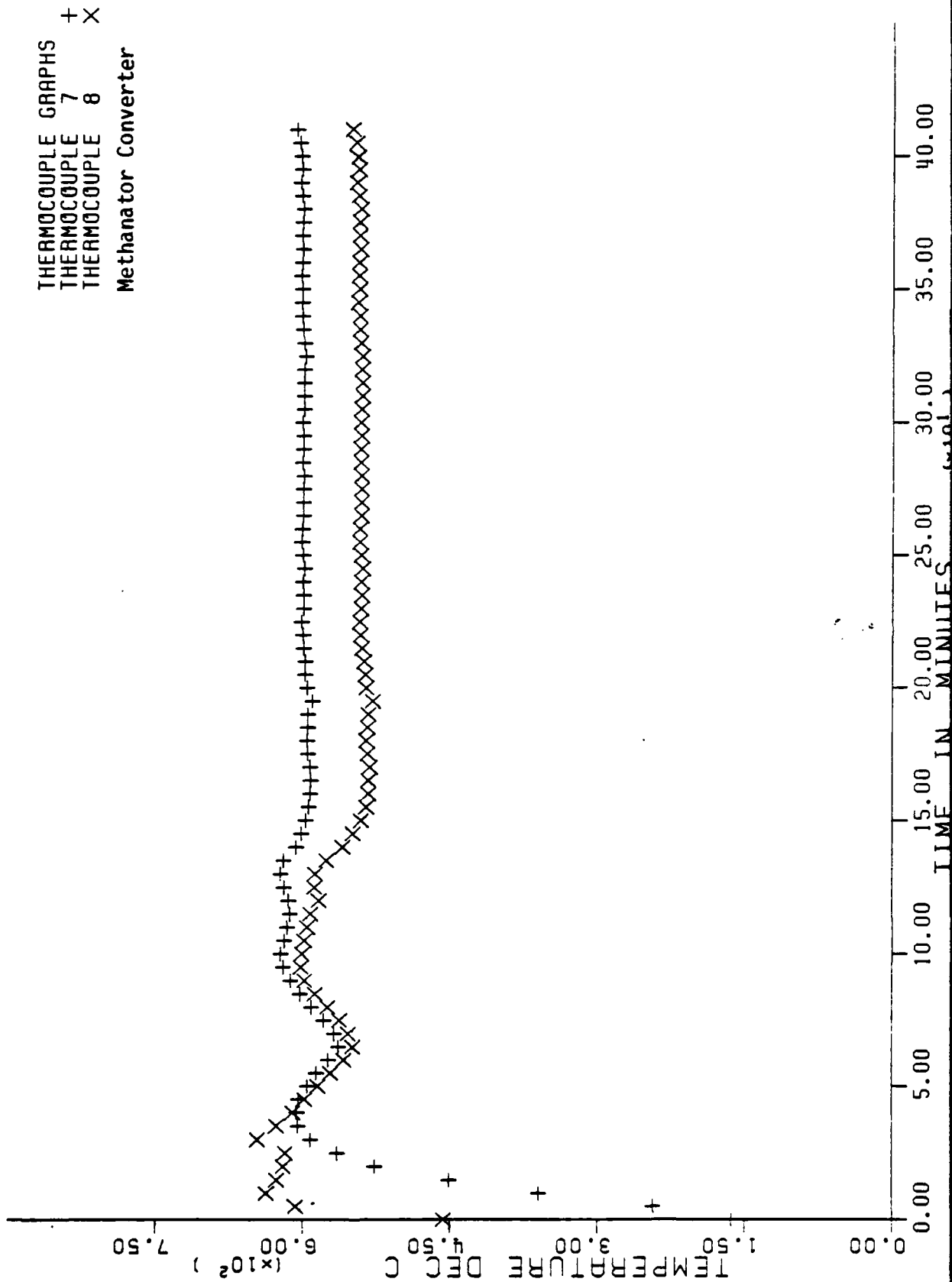

FIGURE 24.

Sept. 18, 1981

Run No. 91

Closed Loop

THERMOCOUPLE GRAPHS
THERMOCOUPLE 9 +
THERMOCOUPLE 10 X

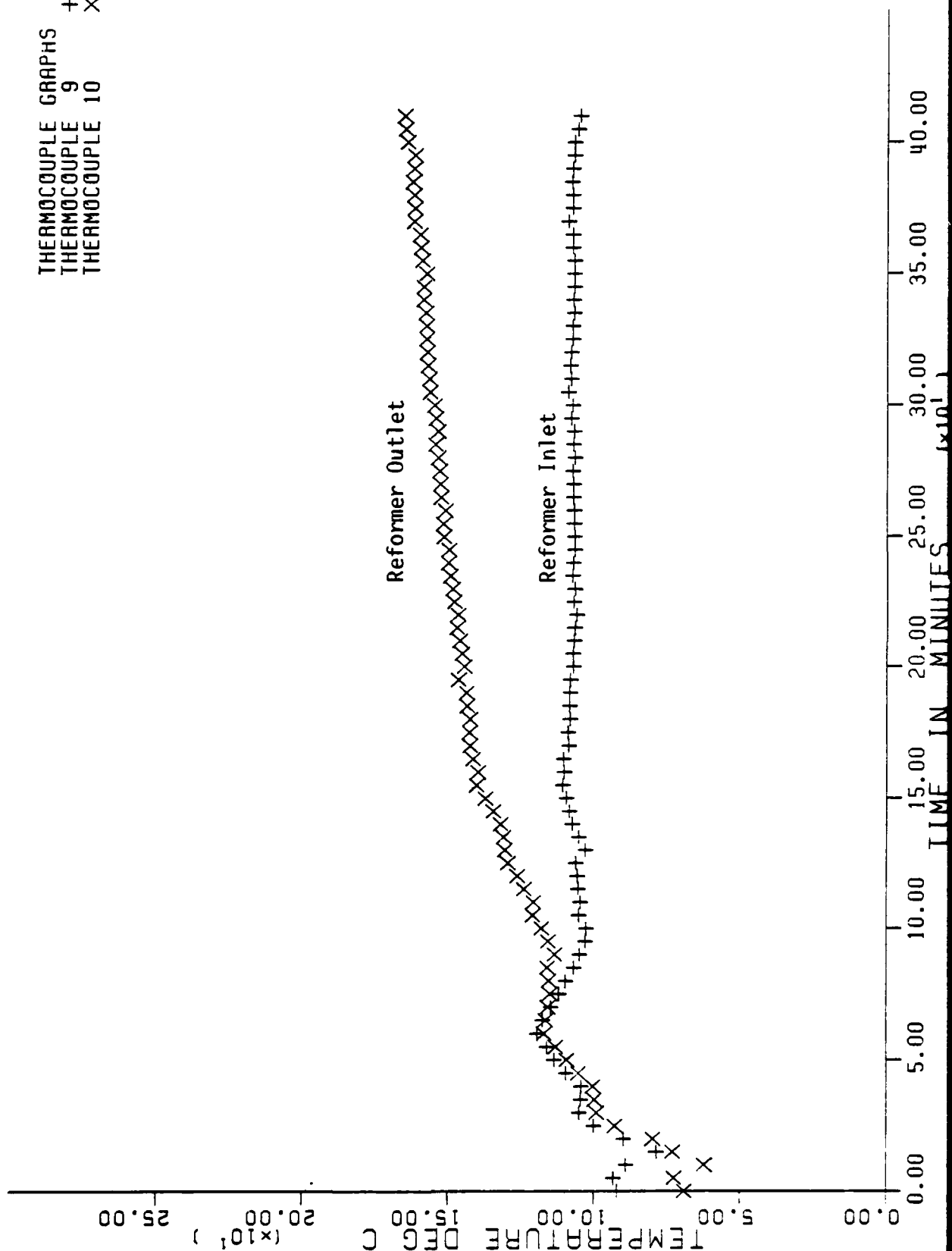
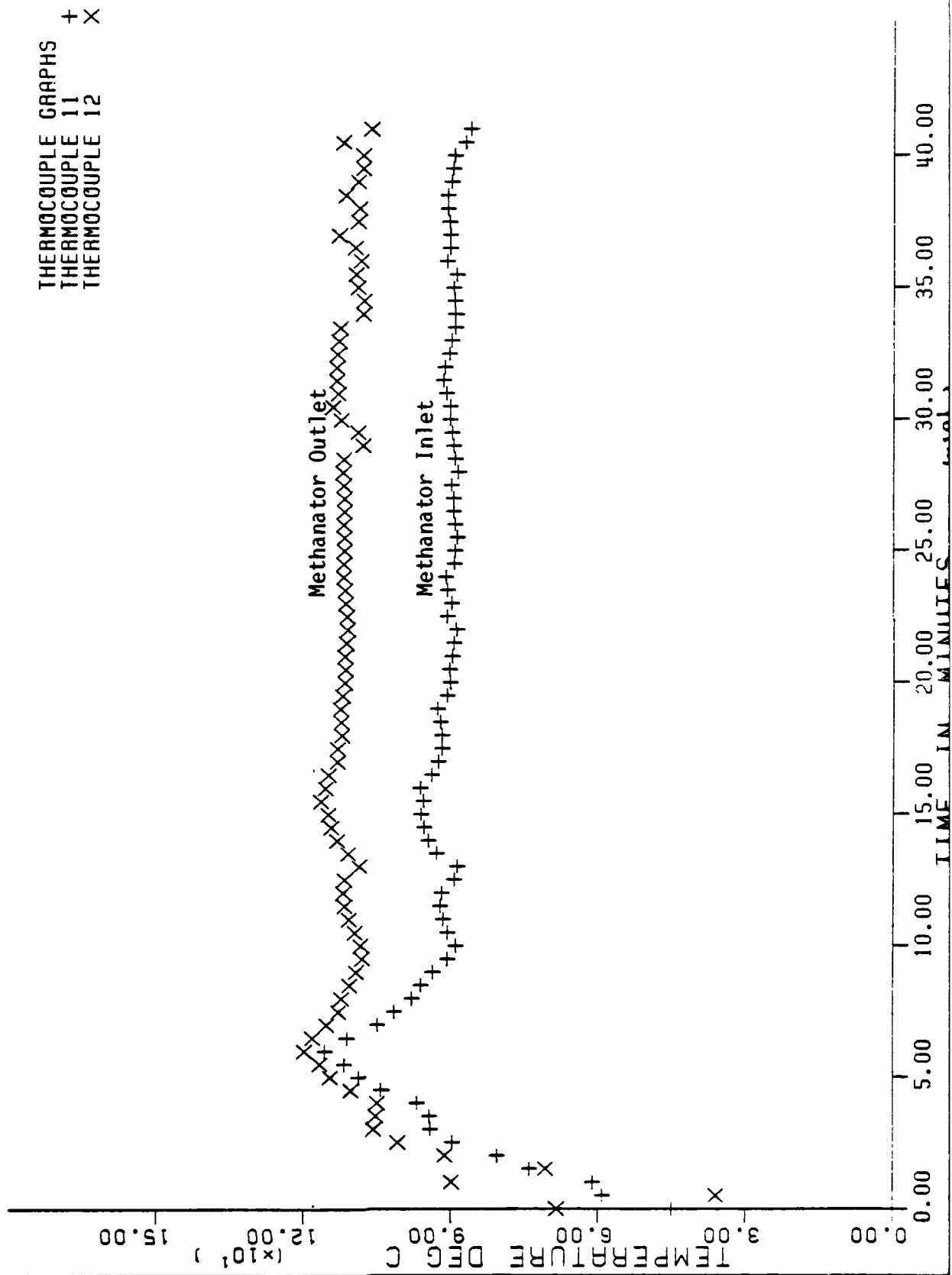

FIGURE 25.

Sept. 18, 1981 Run No. 91 Closed Loop



DISTRIBUTION LIST

NO. OF COPIES

1	C. McDonald/Code 4105.1 Scientific Officer Naval Research Laboratory 4555 Overlook Ave.,SW Washington, DC 20375
1	Commanding Officer, ONR DADAAD Code N62887 1030 E. Green Street Pasadena, California 91106
Letter Of Transmittal	G. Max Irving ONR Resident Representative Department of the Navy Bandolier Hall West - Room 204 University of New Mexico Albuquerque, NM 87131
6	Naval Research Laboratory NRL Code 2627 DODAAD Code N00173 Washington, D.C. 20375
6	ONR/Code 102IP 1030 E. Green Street Pasadena, California 91101
12	Defense Documentation Center Code S47031 Building 5, Cameron Station Alexandria, Virginia 22314
1	A. Gilcrease/PSL
Letter of Transmittal	Contracts/PSL