

AD-A121 601

DRSAR-LEA-L  
TECHNICAL LIBRARY  
Tech. Lib

AD A-121 601

MEMORANDUM REPORT ARBRL-MR-03218

(Supersedes IMR No. 643)

INSTRUMENTATION FOR MEASURING  
PRESSURE WAVES IN GUNS

James W. Evans

November 1982



**US ARMY ARMAMENT RESEARCH AND DEVELOPMENT COMMAND**  
**BALLISTIC RESEARCH LABORATORY**  
**ABERDEEN PROVING GROUND, MARYLAND**

Approved for public release; distribution unlimited.

Destroy this report when it is no longer needed.  
Do not return it to the originator.

Secondary distribution of this report is prohibited.

Additional copies of this report may be obtained  
from the National Technical Information Service,  
U. S. Department of Commerce, Springfield, Virginia  
22161.

The findings in this report are not to be construed as  
an official Department of the Army position, unless  
so designated by other authorized documents.

*The use of trade names or manufacturers' names in this report  
does not constitute indorsement of any commercial product.*

UNCLASSIFIED

SECURITY CLASSIFICATION OF THIS PAGE (When Data Entered)

REPORT DOCUMENTATION PAGE		READ INSTRUCTIONS BEFORE COMPLETING FORM
1. REPORT NUMBER Memorandum Report ARBRL-MR-03218	2. GOVT ACCESSION NO.	3. RECIPIENT'S CATALOG NUMBER
4. TITLE (and Subtitle) Instrumentation For Measuring Pressure Waves In Guns	5. TYPE OF REPORT & PERIOD COVERED	
	6. PERFORMING ORG. REPORT NUMBER	
7. AUTHOR(s) James W. Evans	8. CONTRACT OR GRANT NUMBER(s)	
9. PERFORMING ORGANIZATION NAME AND ADDRESS U.S. Army Ballistic Research Laboratory ATTN: DRDAR-BLI Aberdeen Proving Ground, MD 21005	10. PROGRAM ELEMENT, PROJECT, TASK AREA & WORK UNIT NUMBERS 1L162618AH80	
11. CONTROLLING OFFICE NAME AND ADDRESS U.S. Army Armament Research & Development Command U.S. Army Ballistic Research Laboratory (DRDAR-BL) Aberdeen Proving Ground, MD 21005	12. REPORT DATE November 1982	
	13. NUMBER OF PAGES 18	
14. MONITORING AGENCY NAME & ADDRESS (if different from Controlling Office)	15. SECURITY CLASS. (of this report) UNCLASSIFIED	
	15a. DECLASSIFICATION/DOWNGRADING SCHEDULE	
16. DISTRIBUTION STATEMENT (of this Report)  Approved for public release; distribution unlimited		
17. DISTRIBUTION STATEMENT (of the abstract entered in Block 20, if different from Report)		
18. SUPPLEMENTARY NOTES  Supersedes BRL IMR 643		
19. KEY WORDS (Continue on reverse side if necessary and identify by block number) Transducer Calibration Piezoelectric Charge Amplifier Differential Pressure Pressure Measurement		
20. ABSTRACT (Continue on reverse side if necessary and identify by block number) The continuous measurement of the pressure difference between the breech and forward ends of a cannon chamber is used by the charge designer to make an evaluation of the ignition process and to determine the existence of pressure waves. The technique of making this measurement involves the analog differencing of two optimally located transducers with a recording system that is properly adjusted, calibrated, and scaled. The resulting differential pressure versus time relationship reveals wave structure that may not be obvious by visual inspection of the two original pressure-time curves.		

TABLE OF CONTENTS

	<u>Page</u>
LIST OF FIGURES. . . . .	5
I. INTRODUCTION . . . . .	7
II. PRESSURE MEASUREMENT TECHNIQUES. . . . .	8
A. Basic Pressure Measurement . . . . .	8
B. Differential Pressure Measurement . . . . .	10
III. RESULTS. . . . .	14
DISTRIBUTION LIST . . . . .	17

LIST OF FIGURES

<u>No.</u>		<u>Page</u>
1.	Pressure Transducer Locations . . . . .	7
2.	Data Format . . . . .	9
3.	Basic Piezoelectric Pressure Measurement . . . . .	9
4.	Differential Pressure Measurement . . . . .	11
5.	Pressure-Analog Voltage Relationship . . . . .	12
6.	Differential Pressure-Analog Voltage Relationship . . . . .	14
7.	Typical Data, No Pressure Waves . . . . .	15
8.	Typical Data, Large Pressure Waves . . . . .	16

## I. INTRODUCTION

During the study of interior ballistic phenomena, it is desirable at times to difference two analog pressure signals and display the calibrated output. This technique is particularly useful in the study of propellant charge ignition<sup>1,2</sup>. From the difference of a pressure transducer located in the breech of a gun and one located in the side wall of the chamber near the rear of the projectile (Figure 1), the charge designer can make an evaluation of the ignition process and determine the existence of pressure waves, even if they are of very low amplitude. The resulting differential pressure versus time relationship reveals wave structures that would not be obvious by visual inspection of two original pressure-time curves.

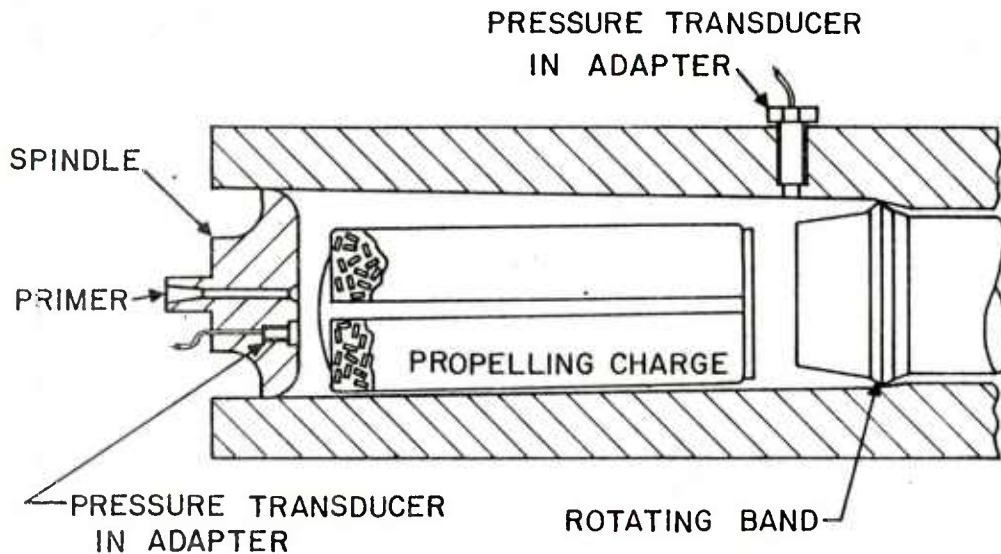

Figure 1. Pressure Transducer Locations

The technique described here is particularly useful when operating in the field where data are recorded on analog magnetic tape and played back at reduced speed on a chart recorder. An initial appraisal of the data can be made on site without the necessity of processing at a data reduction facility.

<sup>1</sup>I. W. May, E. V. Clarke, Jr., H. Hassmann, "A Case History: Gun Ignition Related Problems and Solutions for the XM-198 Howitzer," *Proceedings of the International Symposium on Gun Propellants, Picatinny Arsenal, 15-19 October 1973.*

<sup>2</sup>I. W. May, E. V. Clarke, Jr., "The Reverse Chamber Pressure Gradient: A Tool for Assessing the Effects of Wave Dynamics on the Ballistic Performance of Guns," *Proceedings of the Second International Symposium on Ballistics, Sponsored by the American Defense Preparedness Association, Daytona Beach, Florida, 9-11 March 1976.*

## II. PRESSURE MEASUREMENT TECHNIQUES

### A. Basic Pressure Measurement

In order to keep the data reduction process compatible with existing in-house hardware, data reduction programs, and procedures; a standard format<sup>3</sup> is used. This format has five linear calibration steps, each with a 50-millisecond duration, preceding the analog voltage data as shown in Figure 2. When a piezoelectric transducer and charge amplifier<sup>4</sup> are used for making the pressure measurement, the calibration is realized through the charge amplifier calibration port (Figure 3). This input is coupled to the charge amplifier through a built-in 1000-picofarad capacitor and the top step calibration voltage is chosen to induce a charge on this capacitor somewhat greater than the charge that will be generated by the transducer at the maximum expected pressure. The calibration voltage is determined by the relationship:

$$V_c = q_c/C \quad (1)$$

Where:

$V_c$  = Calibration voltage, top step (volts)

$q_c$  = Charge induced by the top step calibration voltage (picocoulombs)

$C$  = Capacitance of the calibration capacitor (picofarads)

The charge generated by the transducer at an "even" value of pressure somewhat greater than the maximum pressure is:

$$q_t = k P_t \quad (2)$$

Where:

$q_t$  = Charge generated by the transducer at  $P_t$  (picocoulombs)

$k$  = Transducer linear calibration constant (picocoulombs/lb/in.<sup>2</sup>)

$P_t$  = Pressure at top calibration step (lb/in.<sup>2</sup>)

$$\text{if: } q_c = q_t$$

$$\text{Then: } V_c = k P_t/C \quad (3)$$

<sup>3</sup>C.L. Henry, R. L. Martz, E. M. Wineholt, "An Improved Procedure for the Reduction of Interior Ballistic Data Recorded on Analog Tape," Ballistic Research Laboratories Memorandum Report No. 2374, April 1974 (AD#919924L)

<sup>4</sup>"Model 504E4 Dual-Mode Amplifier Instruction Manual," Sundstrand Data Control, Inc., Redmond, Washington 98052

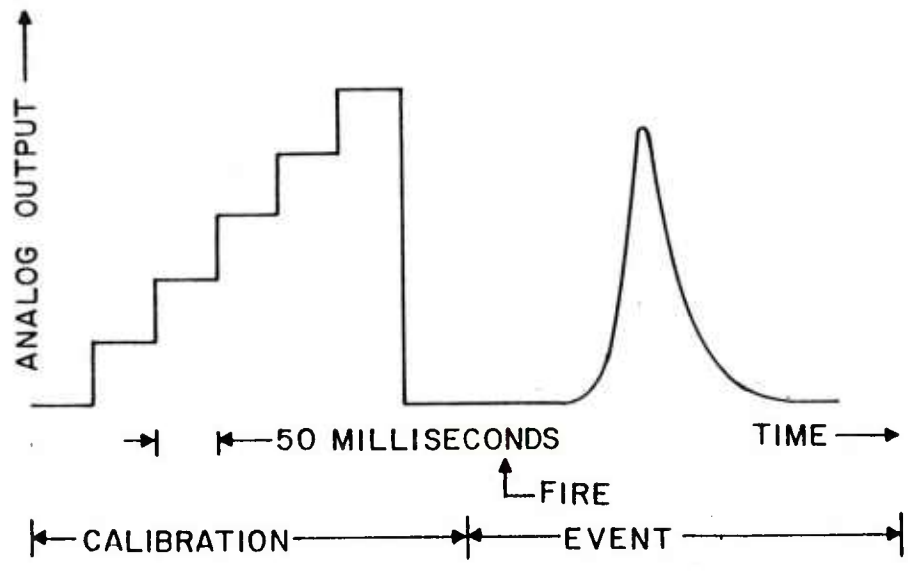

Figure 2. Data Format

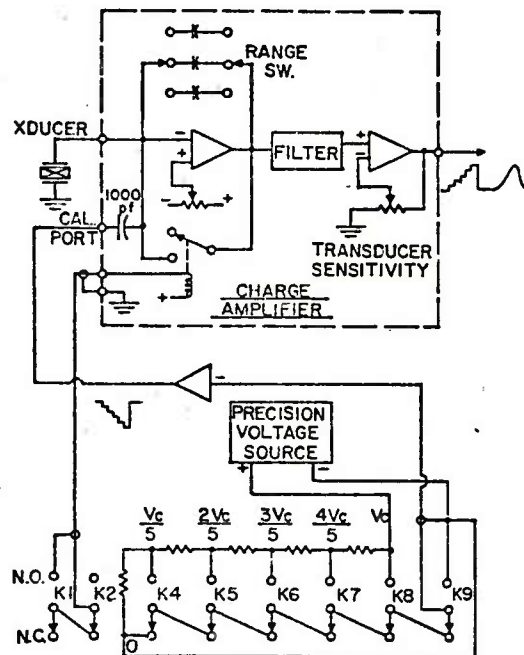

Figure 3. Basic Piezoelectric Pressure Measurement

The charge amplifier's analog voltage output can be adjusted to the desired magnitude with the "range switch" (R) and the "transducer sensitivity" (S) setting<sup>4</sup>. The overall gain of the charge amplifier is the product of R and S, which is set to the desired gain by:

$$RS = kP_t/V_o = V_c C/V_o \quad (4)$$

Where:

R = Charge amplifier range switch setting ( $\frac{\text{lb/in.}^2}{\text{volt}}$ )  
(R = 1, 2, 5, 10,.....,5K)

S = Charge amplifier transducer sensitivity setting S = 1 to 11  
(picocoulombs/lb/in.<sup>2</sup>)

V<sub>o</sub> = Required analog output for P<sub>t</sub> (volts)

Note: English units are used here since most commercial charge amplifiers and transducers are calibrated using these units.

Just prior to calibration, the charge amplifier's feedback capacitor is remotely shorted for several milliseconds to eliminate any stray charge. This is done with two relay stages (K<sub>1</sub> and K<sub>2</sub>) of a pre-programmed sequence timer. The voltage staircase is generated from a precision voltage source and series connected precision resistors. The pre-programmed sequence timer energizes in sequence the relays (K<sub>4</sub> through K<sub>9</sub>) that are connected as shown in Figure 3. An amplifier with unity gain is used to insure that the calibration circuit is not overloaded since it may be used to calibrate more than one amplifier. This is a so-called "end-to-end" calibration and calibrates the entire data circuit with the exception of the transducer.

#### B. Differential Pressure Measurement

The pressure difference of two analog pressure signals is derived using the system shown in Figure 4. It is important that the paths of the analog signals are identical to avoid errors due to phase shifts and slew rates. The two charge amplifiers (Q<sub>1</sub> and Q<sub>2</sub>) use the same calibration and remote short circuits. When selecting the calibration voltage, consideration must be given to the fact that the calibration constants for the transducers may be different and the greater value should be used to calculate the calibration voltage. It is desirable that the transducers have nearly the same parameters and those selected have the most linear outputs. It is necessary that the magnitude of the input voltages (V<sub>1</sub>' and V<sub>2</sub>') to the differential amplifier (A<sub>3</sub>) represent the same pressure magnitude and that they be compatible with the recording device. For an FM channel of a magnetic tape recorder, the required input signal is usually one volt RMS. In this general case it is selected as plus and minus a band edge voltage ( $\pm V_E$ ). To make the analog data from the two transducers compatible, every circuit in the system must be precisely adjusted. Assuming that from the calibration of the selected transducers, pressure (P<sub>t1</sub>) is greater than pressure (P<sub>t2</sub>) for the top calibration step. This will serve as a basis for adjusting the various circuits. The output of charge amplifier (Q<sub>1</sub>) is adjusted to have

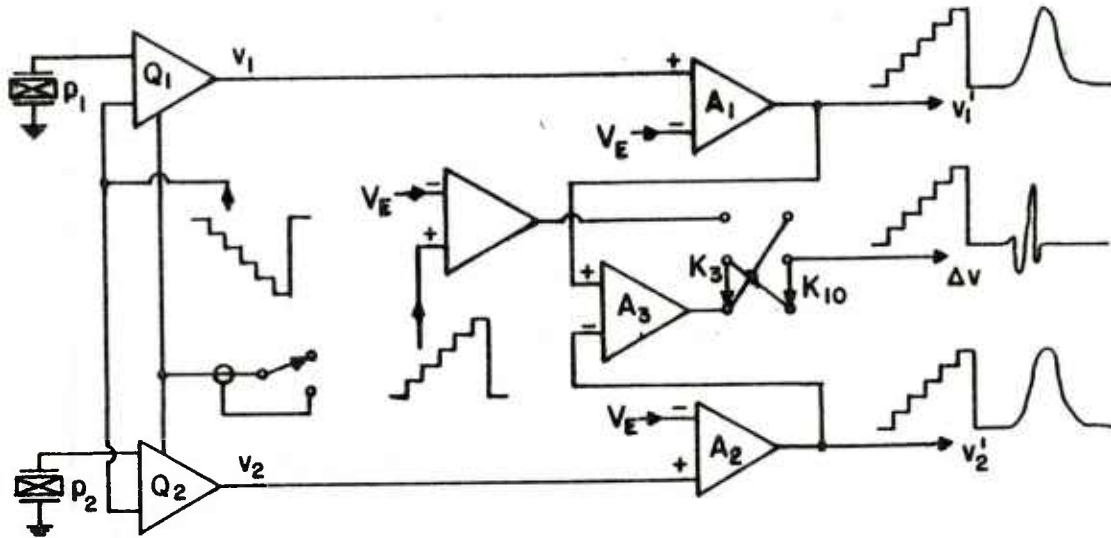

Figure 4. Differential Pressure Measurement

the following values:

@ Calibration baseline

$$P_{b_1} = 0 \quad ; \quad V_{b_1} = 0$$

@ Top Calibration step

$$P_{t_1} = V_c C / k_1 \quad ; \quad V_{t_1} = 2 V_E$$

This is accomplished by calculating the charge amplifier settings (R and S) using Equation (4) with  $2V_E$  as the required output for the top calibration step. Several combinations of R and S are possible for each calculated condition. Once the selected R and S combination is set, the output conditions can be monitored while manually operating sequence timer stage  $K_8$  to impress the top calibration step. It may be necessary to adjust the amplifier zero and the transducer sensitivity setting to compensate for dial inaccuracies. The remote short should be activated just before making zero adjustments to remove any stray charge. From the conditions adjusted into  $Q_1$  and assuming that the system is linear, it follows that the relationship of the pressure to the analog voltage is:

$$v = 2V_E (k_1 / V_c C) p \quad (5)$$

Where:

v = variable voltage output (volts)

P = variable pressure (lb/in.<sup>2</sup>)

This is graphically depicted in Figure 5 as the linear equation that passes through the point (0,0) and ( $P_{t_1}, V_{t_1}$ ). Using this relationship and manually operating sequence times stages  $K_4$  through  $K_9$  while observing  $Q_1$  output, the linearity of the system can be determined. Charge amplifier

$Q_2$  is then adjusted to have the same pressure-voltage relationship as  $Q_1$ . It is obvious that the calibration baseline should have the values:

$$P_{b2} = 0 \quad ; \quad V_{b2} = 0$$

Using Equations (3) and (5), the top calibration step values are determined as follows:

$$P_{t2} = V_{cC}/k_2 \quad ; \quad V_{t2} = 2V_E(k_1/k_2)$$

This is shown as point  $(P_{t2}, V_{t2})$  on figure 5.

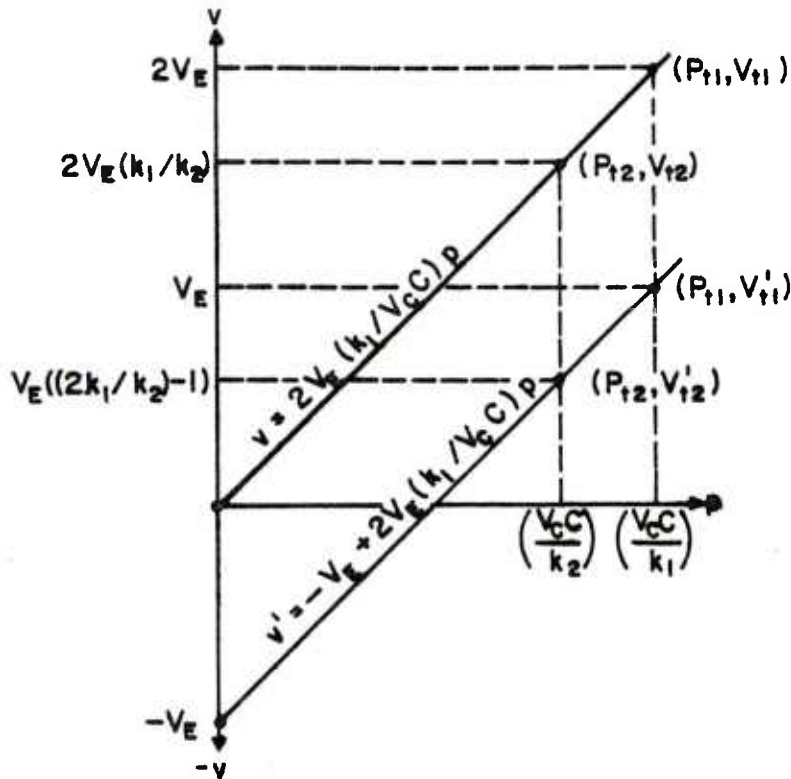

Figure 5. Pressure-Analog Voltage Relationship

Amplifiers  $A_1$  and  $A_2$  should be adjusted for unity gain with the analog signals fed into the non-inverting inputs. A voltage source is fed into the inverting inputs to offset the output by the negative band edge voltage  $(-V_E)$  for compatibility with the recording device. (On some amplifiers, this function is internally incorporated). The expression for the pressure-voltage relationship at the outputs of  $A_1$  and  $A_2$  is:

$$v' = -V_E + 2V_E (k_1/V_{cC})p \quad (6)$$

This relationship is shown graphically on Figure 5. The calibration baseline values for amplifiers A<sub>1</sub> and A<sub>2</sub> are:

$$\begin{aligned} P_{b_1} &= 0 & ; & & V_{b_1} &= -V_E \\ P_{b_2} &= 0 & ; & & V_{b_2} &= -V_E \end{aligned}$$

Using Equations (3) and (6), the top calibration step values are determined as follows:

$$\begin{aligned} P_{t_1} &= V_c C / K_1 & ; & & V_{t_1} &= V_E \\ P_{t_2} &= V_c C / K_2 & ; & & V_{t_2} &= V_E [(2k_1/k_2) - 1] \end{aligned}$$

The output of differential amplifier A<sub>3</sub> is the analog voltage ( $\Delta v$ ) of the differential pressure ( $\Delta p$ ). The inputs, in this configuration, are from amplifiers A<sub>1</sub> and A<sub>2</sub>, but could have been from Q<sub>1</sub> and Q<sub>2</sub>. The former configuration was selected for convenience since the recording system had monitor points at the A<sub>1</sub> and A<sub>2</sub> outputs. This additional rank of amplifiers that the differential signal must pass was insignificant because of the relatively wide bandwidth and fast slew rate of the amplifiers. The analytical expression for the output of A<sub>3</sub> is:

$$\begin{aligned} \Delta v &= G(v_1' - v_2') \\ &= G[2V_E (k_1/V_c C) (p_1 - p_2)] \\ &= 2GV_E (k_1/V_c C) \Delta p \end{aligned} \tag{7}$$

Where: G = Voltage gain of A<sub>3</sub>

To make the differential pressure data consistent with the data format<sup>3</sup>, it is necessary that the analog signal be preceded by calibration steps. The signal is interrupted by switching to a voltage staircase during the normal calibration cycle and switching back to the amplifier output when calibration is completed. This is done by two stages of the pre-programmed sequence timer (K<sub>3</sub> and K<sub>10</sub>). The voltage staircase is generated by a circuit similar to the one that calibrates the charge amplifier and is time-coordinated with it. Baseline (-V<sub>E</sub>) and top-step voltages (+V<sub>E</sub>) are adjusted to the same magnitude as the calibration staircase of A<sub>1</sub>.

The quiescent state of amplifier (A<sub>3</sub>) at zero differential pressures is zero volts and during the dynamic event can swing both positive and negative. This implies that zero pressure does not coincide with the baseline but lies mid-way between the baseline and the top calibration step. This is depicted graphically as Figure 6. Values at the calibration baseline and calibration top step, calculated from Equation 7, are as follows:

$$\Delta V_b = -V_E \quad ; \quad \Delta P_b = -\frac{1}{2G_1} (V_c C/k_1)$$

@ Top Calibration step

$$\Delta V_t = +V_E \quad ; \quad \Delta P_t = \frac{1}{2G_1} (V_c C/k_1)$$

Since the analog of the differential pressure is a function of amplifier  $A_3$  gain, it is necessary that the gain be precisely known and that it is adjusted for the expected differential pressure.

### III. RESULTS

Typical examples of data acquired using the described techniques are shown in Figures 7 and 8. These data are from experimental propelling charge and igniter configurations. From the  $\Delta p$  versus time plots, the charge designer can evaluate the ignition process as described in References 1 and 2. Figure 7 is an example of a good ignition as evidenced by the normal non-oscillatory positive pressure difference. Figure 8 is an example where abnormal pressure waves exist with the substantial negative pressure gradient indicating poor ignition.

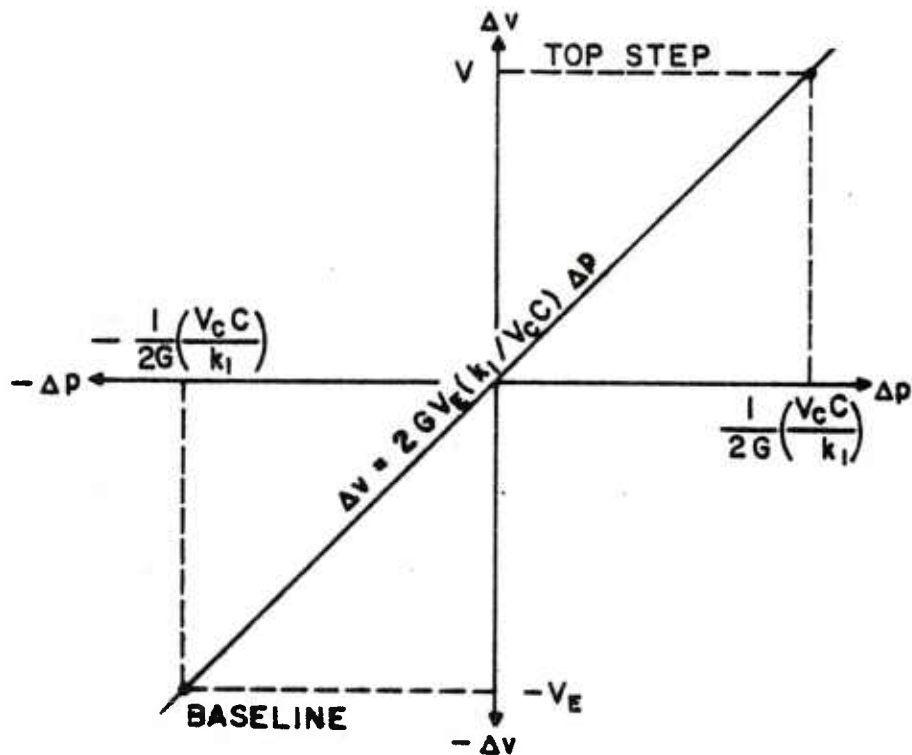

Figure 6. Differential Pressure-Analog Voltage Relationship

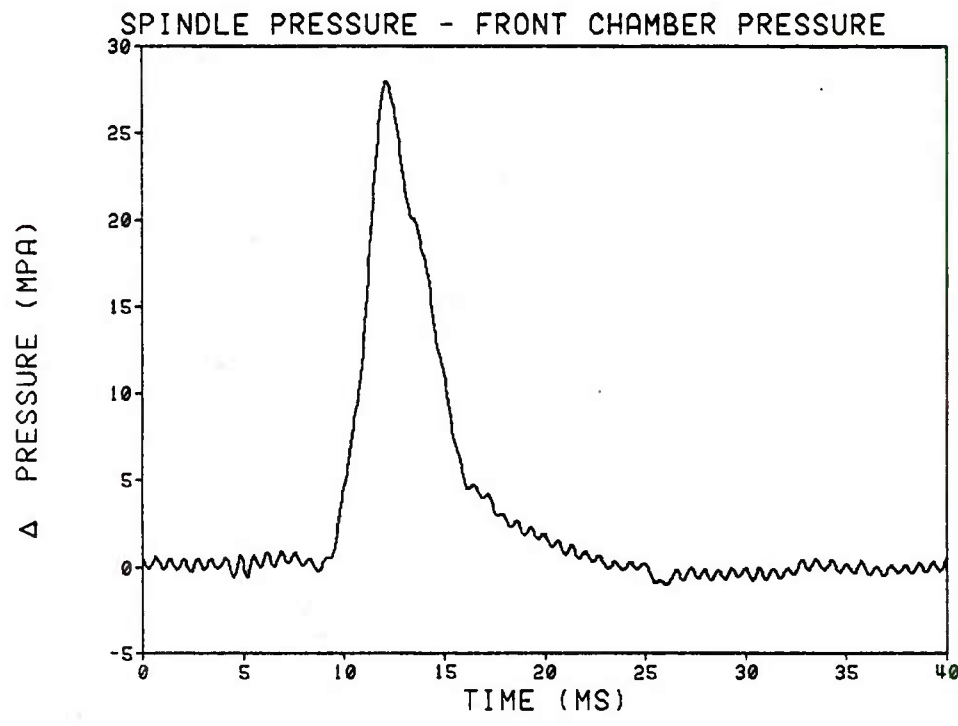
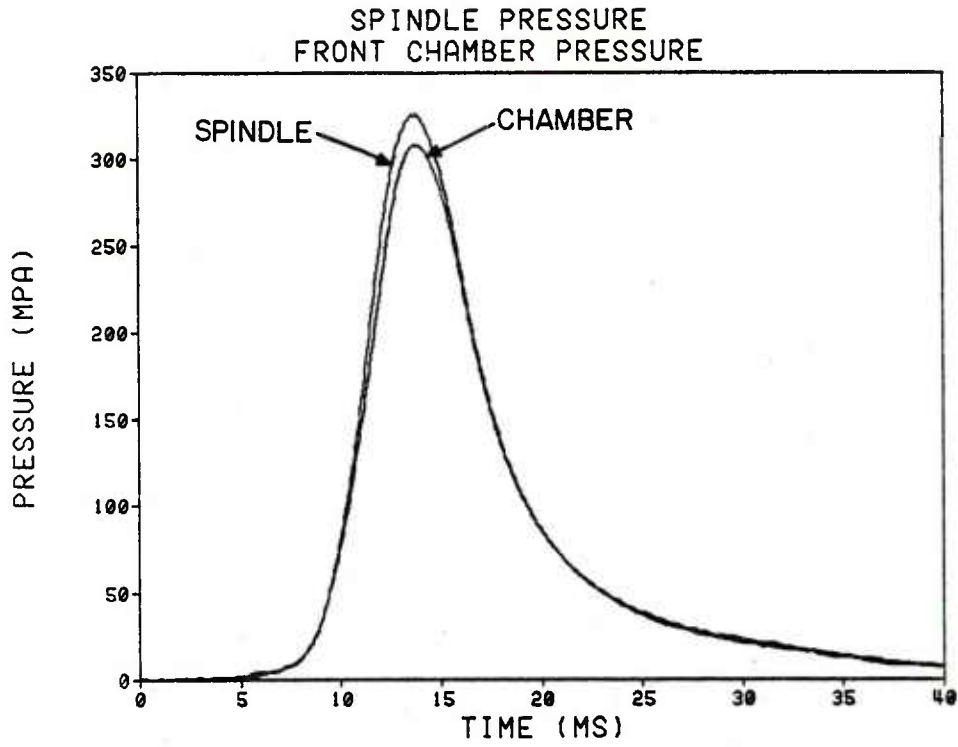

Figure 7. Typical Data, No Pressure Waves

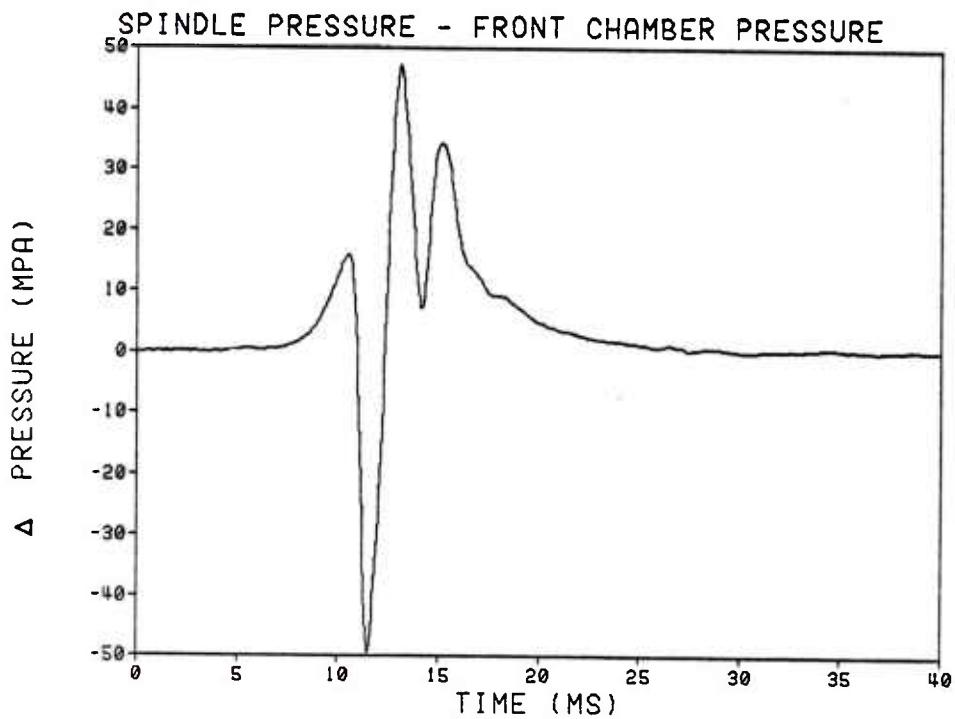
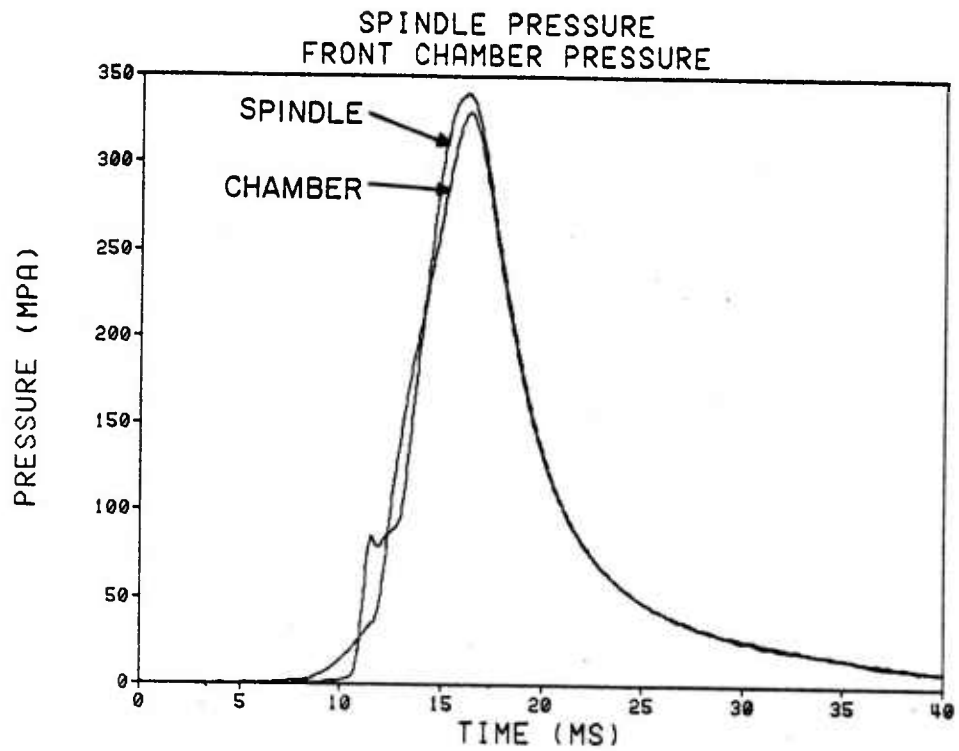

Figure 8. Typical Data, Large Pressure Waves

DISTRIBUTION LIST

<u>No. Of Copies</u>	<u>Organization</u>	<u>No. Of Copies</u>	<u>Organization</u>
12	Administrator Defense Technical Info Center ATTN: DTIC-DDA Cameron Station Alexandria, VA 22314	3	Director US Army ARRADCOM Benet Weapons Laboratory ATTN: DRDAR-LCB-TL DRDAR-LCB, Mr. W. Austin DRDAR-LCB-RM, D. Kendall Watervliet, NY 12189
1	Commander US Army Materiel Development and Readiness Command ATTN: DRCDMD-ST 5001 Eisenhower Avenue Alexandria, VA 22333	1	Commander US Army Aviation Research and Development Command ATTN: DRDAV-E 4300 Goodfellow Blvd. St. Louis, MO 63120
9	Commander US Army Armament R&D Command ATTN: DRDAR-TSS (2 cys) DRDAR-TDC DRDAR-LCA, S. Westley D. Gulliksen D. Collette DRDAR-LCA-G, K. Klingaman S. Bernstein DRDAR-BE-IA, L. Goldsmith Dover, NJ 07801	1	Director US Army Air Mobility Research And Development Laboratory Ames Research Center Moffett Field, CA 94035
3	Commander US Army Armament R&D Command ATTN: DRCPM-CAWS, F. Menke H. Noble Dover, NJ 07801	1	Commander US Army Communications Research and Development Command ATTN: DRDCO-PPA-SA Fort Monmouth, NJ 07703
3	Project Manager Cannon Artillery Weapons System DRCPM-CAWS-AM, R. DeKleine H. Hassmann Dover, NJ 07801	1	Commander US Army Electronics Research and Development Command Technical Support Activity ATTN: DELSD-L Fort Monmouth, NJ 07703
1	Commander US Army Armament Materiel Readiness Command ATTN: DRSAR-LEP-L, Tech Lib Rock Island, IL 61299	2	Commander US Army Missile Command ATTN: DRSMI-R DRSMI-YDL Redstone Arsenal, AL 35898
		3	Commander US Army Dugway Proving Ground ATTN: STEDP-MT, Mr. W. Dyer Mr. J. Deale Mr. C. Dewitt Dugway, UT 84022

DISTRIBUTION LIST

<u>No. Of Copies</u>	<u>Organization</u>	<u>No. Of Copies</u>	<u>Organization</u>
2	Commander US Army Materiel Testing Directorate ATTN: STEJP-MT, V. Gudkese M. Shepherd Jefferson Proving Ground Madison, IN 47251	1	Princeton Combustion Research Lab., Inc. ATTN: M. Summerfield 1041 US Highway One North Princeton, NJ 08540
2	Commander US Army Materiel Testing Directorate ATTN: SEEYP-MC, W. Phillips J. Gallett Yuma Proving Ground Yuma AZ 85364	1	Commander Naval Ordnance Station ATTN: Code 5254 E, F. Drinkard Indian Head, MD 20640
			<u>Aberdeen Proving Ground</u>
1	Commander Hawthorne Army Ammo Plant ATTN: Mr. V. C. Miller Hawthorne, CA 90250		Dir, USAMSAA ATTN: DRXSY-D DRXSY-MP, H. Cohen Cdr, USATECOM ATTN: DRSTE-TO-F DRSTE-AD-M, J. Gehrig STEAP-MT, S. Walton D. Lacey C. Herud K. Balliet
1	Commander US Army Tank Automotive Research and Development Command ATTN: DRDTA-UL Warren, MI 48090		Dir, USACSL, Bldg. E3516, EA ATTN: DRDAR-CLB-PA
1	Director US Army TRADOC Systems Analysis Activity ATTN: ATAA-SL, Tech Lib White Sands Missile Range, NM 88002		
2	Commander Naval Surface Weapons Center ATTN: Code G33, J. L. East D. McClure Dahlgren, VA 22448		
1	Commander Naval Surface Weapons Center Silver Spring, MD 20910		

USER EVALUATION OF REPORT

Please take a few minutes to answer the questions below; tear out this sheet, fold as indicated, staple or tape closed, and place in the mail. Your comments will provide us with information for improving future reports.

1. BRL Report Number \_\_\_\_\_

2. Does this report satisfy a need? (Comment on purpose, related project, or other area of interest for which report will be used.)

\_\_\_\_\_  
\_\_\_\_\_  
\_\_\_\_\_

3. How, specifically, is the report being used? (Information source, design data or procedure, management procedure, source of ideas, etc.) \_\_\_\_\_

\_\_\_\_\_  
\_\_\_\_\_

4. Has the information in this report led to any quantitative savings as far as man-hours/contract dollars saved, operating costs avoided, efficiencies achieved, etc.? If so, please elaborate.

\_\_\_\_\_  
\_\_\_\_\_

5. General Comments (Indicate what you think should be changed to make this report and future reports of this type more responsive to your needs, more usable, improve readability, etc.) \_\_\_\_\_

\_\_\_\_\_  
\_\_\_\_\_  
\_\_\_\_\_

6. If you would like to be contacted by the personnel who prepared this report to raise specific questions or discuss the topic, please fill in the following information.

Name: \_\_\_\_\_

Telephone Number: \_\_\_\_\_

Organization Address: \_\_\_\_\_

\_\_\_\_\_  
\_\_\_\_\_