

AD-A121 603

TECHNICAL
LIBRARY

AD#-121603

MEMORANDUM REPORT ARBRL-MR-03208

(Supersedes IMR No. 735)

PRESSURE MEASUREMENTS OF A ROTATING
LIQUID FOR IMPULSIVE CONING MOTION

William P. D'Amico, Jr.
William G. Beims
Thomas H. Rogers

November 1982



US ARMY ARMAMENT RESEARCH AND DEVELOPMENT COMMAND
BALLISTIC RESEARCH LABORATORY
ABERDEEN PROVING GROUND, MARYLAND

Approved for public release; distribution unlimited.

Destroy this report when it is no longer needed.
Do not return it to the originator.

Secondary distribution of this report is prohibited.

Additional copies of this report may be obtained
from the National Technical Information Service,
U. S. Department of Commerce, Springfield, Virginia
22161.

The findings in this report are not to be construed as
an official Department of the Army position, unless
so designated by other authorized documents.

*The use of trade names or manufacturers' names in this report
does not constitute indorsement of any commercial product.*

UNCLASSIFIED

SECURITY CLASSIFICATION OF THIS PAGE (When Data Entered)

| REPORT DOCUMENTATION PAGE | | READ INSTRUCTIONS BEFORE COMPLETING FORM |
|---|-----------------------|---|
| 1. REPORT NUMBER Memorandum Report ARBRL-MR-03208 | 2. GOVT ACCESSION NO. | 3. RECIPIENT'S CATALOG NUMBER |
| 4. TITLE (and Subtitle) Pressure Measurements of a Rotating Liquid for Impulsive Coning Motion | | 5. TYPE OF REPORT & PERIOD COVERED Final |
| | | 6. PERFORMING ORG. REPORT NUMBER |
| 7. AUTHOR(s) William P. D'Amico, Jr. William G. Beims Thomas H. Rogers | | 8. CONTRACT OR GRANT NUMBER(s) |
| 9. PERFORMING ORGANIZATION NAME AND ADDRESS US Army Ballistic Research Laboratory ATTN: DRDAR-BLL Aberdeen Proving Ground, MD 21005 | | 10. PROGRAM ELEMENT, PROJECT, TASK AREA & WORK UNIT NUMBERS RDT&E 1L162618AH80 |
| 11. CONTROLLING OFFICE NAME AND ADDRESS US Army Armament Research and Development Command US Army Ballistic Research Laboratory (DRDAR-BL) Aberdeen Proving Ground, MD 21005 | | 12. REPORT DATE November 1982 |
| | | 13. NUMBER OF PAGES 49 |
| 14. MONITORING AGENCY NAME & ADDRESS (if different from Controlling Office) | | 15. SECURITY CLASS. (of this report) UNCLASSIFIED |
| | | 15a. DECLASSIFICATION/DOWNGRADING SCHEDULE |
| 16. DISTRIBUTION STATEMENT (of this Report) Approved for public release; distribution unlimited. | | |
| 17. DISTRIBUTION STATEMENT (of the abstract entered in Block 20, if different from Report) | | |
| 18. SUPPLEMENTARY NOTES Supersedes IMR 735 dated December 1981. | | |
| 19. KEY WORDS (Continue on reverse side if necessary and identify by block number) Pressure Measurements Rotating Liquids Telemetry | | |
| 20. ABSTRACT (Continue on reverse side if necessary and identify by block number) (1cb) A spinning cylinder which contained a liquid in rigid body rotation was impulsively forced to cone at a small angle away from a vertical orientation. The response of the fluid to this abrupt, circular coning motion was measured by pressure transducers that were located in the end wall of the cylinder. The time for the fluid to achieve a steady state response to the impulsive coning motion was several seconds. Cone-up times were experimentally determined for a range of coning frequencies. The Reynolds number was 5.23×10^5 . In general, the cone-up times were comparable in magnitude to the spin-up time (the time required by the | | |

DD FORM 1 JAN 73 1473

EDITION OF 1 NOV 65 IS OBSOLETE

UNCLASSIFIED

SECURITY CLASSIFICATION OF THIS PAGE (When Data Entered)

20. ABSTRACT (Continued):

liquid to adjust to an impulsive change in the spin rate of the cylinder). These experiments indicate that numerical simulations for liquid payloads carried by spin-stabilized, gun launched projectiles must account for both spin-up and cone-up and that these effects must be treated simultaneously.

TABLE OF CONTENTS

| | <u>Page</u> |
|---|-------------|
| LIST OF FIGURES | 5 |
| LIST OF APPENDIX FIGURES | 6 |
| I. INTRODUCTION | 7 |
| II. DESCRIPTION OF EXPERIMENTS | 9 |
| III. EXPERIMENTAL RESULTS | 10 |
| A. Coning Angle of 0.02deg | 10 |
| B. Coning Angle of 0.05deg | 11 |
| IV. DETERMINATION OF THE CONE-UP TIME | 11 |
| V. CONCLUSIONS | 13 |
| VI. ACKNOWLEDGEMENT | 13 |
| REFERENCES | 14 |
| APPENDIX A | 33 |
| DISTRIBUTION LIST | 45 |

LIST OF FIGURES

| <u>Figure</u> | | <u>Page</u> |
|---------------|--|-------------|
| 1. | Gimbal Case | 15 |
| 2. | Placement of Pressure Transducers | 16 |
| 3. | Typical Coning Frequency Histories | 17 |
| 4. | Pressure Response Curve | 18 |
| 5a. | Pressure versus Time for $\omega=3.5\text{Hz}$ and $\epsilon=0.02\text{deg}$ | 19 |
| 5b. | Pressure versus Time for $\omega=3.75\text{Hz}$ and $\epsilon=0.02\text{deg}$ | 20 |
| 5c. | Pressure versus Time for $\omega=3.918\text{Hz}$ and $\epsilon=0.02\text{deg}$ | 21 |
| 5d. | Pressure versus Time for $\omega=4.0\text{Hz}$ and $\epsilon=0.02\text{deg}$ | 22 |
| 5e. | Pressure versus Time for $\omega=4.168\text{Hz}$ and $\epsilon=0.02\text{deg}$ | 23 |
| 6a. | Pressure versus Time for $\omega=3.5\text{Hz}$ and $\epsilon=0.05\text{deg}$ | 24 |
| 6b. | Pressure versus Time for $\omega=3.75\text{Hz}$ and $\epsilon=0.05\text{deg}$ | 25 |
| 6c. | Pressure versus Time for $\omega=3.918\text{Hz}$ and $\epsilon=0.05\text{deg}$ | 26 |
| 6d. | Pressure versus Time for $\omega=4.0\text{Hz}$ and $\epsilon=0.05\text{deg}$ | 27 |
| 6e. | Pressure versus Time for $\omega=4.168\text{Hz}$ and $\epsilon=0.05\text{deg}$ | 28 |
| 7. | Cone-Up Time versus Pressure Coefficient -- 0.02deg | 29 |
| 8. | Cone-Up Time versus Pressure Coefficient -- 0.05deg | 30 |
| 9. | Comparison of Pressure Coefficients | 31 |

LIST OF APPENDIX FIGURES

| <u>Figure</u> | | <u>Page</u> |
|---------------|---|-------------|
| A1. | Coning Frequency History: 0.02 Degrees Run #1 | 34 |
| A2. | Coning Frequency History: 0.02 Degrees Run #2 | 35 |
| A3. | Coning Frequency History: 0.02 Degrees Runs #3 and #6 | 36 |
| A4. | Coning Frequency History: 0.02 Degrees Run #4 | 37 |
| A5. | Coning Frequency History: 0.02 Degrees Run #5 | 38 |
| A6. | Coning Frequency History: 0.05 Degrees Runs #1 and #9 | 39 |
| A7. | Coning Frequency History: 0.05 Degrees Runs #2 and #7 | 40 |
| A8. | Coning Frequency History: 0.05 Degrees Runs #3 and #6 | 41 |
| A9. | Coning Frequency History: 0.05 Degrees Runs #4 and #8 | 42 |
| A10. | Coning Frequency History: 0.05 Degrees Run #5 | 43 |

I. INTRODUCTION

The stability of a projectile can be markedly reduced by the presence of a liquid payload. This problem has been addressed analytically and experimentally¹. It can be shown that, if certain natural frequencies of the fluid correspond to the fast precessional frequency of the projectile, a periodic liquid moment is applied to the projectile. This moment can be sufficiently large and produce dramatic flight instabilities. Experimental data are normally gathered by tracking the angular motion of a projectile during flight with yawsondes² or by measuring the yaw history of a freely gimballed gyroscope in the laboratory³. In this study, pressures were measured for a liquid which was spinning as a quasi-rigid body when the container was impulsively subjected to small amplitude circular coning motion. This type of motion will be termed as cone-up.

Pressure measurements for rotating liquids have been made by Aldridge⁴⁻⁶ and by Whiting⁷. These investigations have considered axisymmetric and non-axisymmetric disturbances when the liquid is in rigid body rotation or undergoes spin-up. A schematic of the device used by Whiting is shown in Figure 1. A rotor is held within a cage support. Below the cage, a small DC motor drives the liquid-filled rotor at constant spin rates (normally 83Hz). The spin drive motor is surrounded by a smaller cage which is connected to a bushing that is held in a cam. The position of the bushing in the cam can be set and fixed by a pair of adjustable screws, thus producing an inclination of the spin axis of the rotor/cage support assembly to the vertical. The cam is driven from beneath the support stand by a second DC motor via a belt drive

1. K. Stewartson, "The Stability of a Spinning Top Containing Liquid," Journal of Fluid Mechanics, Vol. 5, 1959, pp. 557-592.
2. Andrew Mark and William H. Mermagen, "Measurement of Spin Decay and Instability of Liquid-Filled Projectiles Via Telemetry," BRL Memorandum Report 2333, October 1973. AD No. 771919.
3. B.G. Karpov, J.T. Frasier, and W.P. D'Amico, "Experimental Studies with a Liquid-Filled Gyroscope," Journal of Spacecraft and Rockets, Vol. 9, No. 3, March 1972, pp. 220-222.
4. K.D. Aldridge, "Experimental Verification of the Inertial Oscillations of a Fluid in a Cylinder During Spin-Up," BRL Contract Report 273, November 1975. AD No. A018797.
5. K.D. Aldridge, "Axisymmetric Inertial Oscillations of a Fluid in a Cylindrical Cavity During Spin-Up from Rest," Geophys. Astrophys. Fluid Dynamics, Vol. 8, 1977, pp. 279-301.
6. K.D. Aldridge and S. Stergiopoulos, "Ringdown of Coupled Inertial Waves in a Rotating Fluid," presented at the Canadian Geophysical Union Meeting, Calgary, Alberta, May 1981.
7. Richard D. Whiting, "An Experimental Study of Forced Asymmetric Oscillations in a Rotating Liquid-Filled Cylinder," BRL Technical Report ARBRL-TR-02376, October 1981. AD No. A107948.

and a pulley. A typical steady coning frequency for this system is 4Hz. A pair of miniature pressure transducers are mounted on the flat surface of an insert which forms the end wall of the liquid-filled cylinder, as shown in Figure 2. The output from the pressure transducers is amplified, conditioned, and transmitted to the laboratory frame via a telemetry system located below the cylinder and within the rotor. The present electronics system permits only the measurement of pressure fluctuations and not steady pressure responses. Further details of the pressure measurement system can be found within Ref. 7.

A short review of some of the basic phenomena common to rotating liquid systems is necessary so that the experimentally determined pressure data can be properly processed and understood. Assuming that the liquid is in a state of rigid body rotation, any disturbance in the motion of the container will generate a system of inertial waves⁸. Once the flow has adjusted to the new motion of the container, the waves will be dissipated by viscosity. If a forced motion of the container is induced and sustained, then the initial circulation of the flow will be modified and the wave motion will persist. If the frequency of the forcing motion is programmable, then the response of the liquid can be measured as a function of the forcing frequency. In the experiments of Whiting, the spin rate, coning rate, and coning angle of the rotor were all constant within a particular experimental trial. Ordinarily, steady state pressure was determined as a function of coning frequency. Subsequently, the coning angle or the kinematic viscosity of the test liquid were changed. Since the pressure of the liquid will depend upon many variables, a pressure coefficient was formulated, $C_p = P/\epsilon\rho\dot{\phi}^2a^2$. If a linear formulation of the pressure is assumed, then a Fourier decomposition should adequately describe the steady state response of the pressure. The magnitude of the Fourier component whose frequency corresponds to the coning frequency of the rotor is defined as P . The density of the liquid is ρ , the spin rate of the rotor is $\dot{\phi}$, the radius of the cylinder is a , and the coning angle is ϵ . The Reynolds number, Re , is defined as $a^2\dot{\phi}/\nu$, where ν is the kinematic viscosity.

In the experiments conducted by Whiting, P was measured after the rotor had been spinning and coning for extremely long times. A range of coning angles were tested to determine the linear regime for C_p . A most startling result was established as a consequence of these experiments: linear behavior for C_p was limited to coning angles no larger than 0.027deg for $Re=5\times 10^5$.

This boundary for linear behavior is dependent upon Re , with larger permissible amplitudes for smaller values of Re . Previous experiments by Scott and D'Amico had shown that linear models for the yaw growth rate of a liquid-filled gyroscope were limited to approximately one degree for a similar Re ⁹. These boundaries for linear behavior are quite disturbing since projectiles typically have Reynolds numbers well in excess of one million and execute angular motions during free flight of several degrees. The additional impact of spin-up from rest or cone-up on these boundaries for linear behavior are

8. H.P. Greenspan, *The Theory of Rotating Fluids*, Cambridge Press, 1969.

9. W.E. Scott and W.P. D'Amico, "Amplitude-Dependent Behavior of a Liquid-Filled Gyroscope," *Journal of Fluid Mechanics*, Vol. 3, 1966, pp. 17-26.

unknown. There have been many investigations and experiments that have determined the time to liquid spin-up within projectiles¹⁰⁻¹¹, but cone-up has not been addressed. The purpose of the present set of experiments is to determine the behavior of the unsteady pressure during cone-up, to determine the time for the liquid to achieve a steady state response, and to determine if the boundary between linear and nonlinear behavior is substantially modified by cone-up.

II. DESCRIPTION OF EXPERIMENTS

The coning device that was used by Whiting was modified to produce impulsive coning motion. A detailed description of the pressure measurement system and the telemetry link is found in Ref. 7. Modifications to the experimental device and supporting equipment were not required except to produce impulsive coning motion. This was done by locating a magnetic clutch on the shaft between the pulley and the cam, which was used to impulsively start or brake the cam. The cam rotation period is monitored by a magnetic sensor. The time between successive pulses from the sensor is processed by a time interval measurement system with a resolution of 0.01ms. These times are inverted to obtain the coning frequency. The generation of impulsive coning motion will present operational difficulties. If rapid rise times are desired, overshoots from the planned steady state coning frequency may occur. A pair of typical coning frequency histories are shown in Figure 3. (All coning histories are provided within Appendix A for reference.) The dashed line represents the desired steady state coning frequency. Operationally, the cam was initially oriented such that the first timing pulse occurred only after 90deg of rotation. This pulse was then used as a starting pulse for the processing of all timing pulses. The coning frequency during the first period of rotation for the cam exceeded the desired steady state frequency of 3.5Hz. The rise time is quite impulsive, but an overshoot in the coning frequency, ω , occurs. Also, a decay to the steady state coning frequency required several seconds. The impact of this overshoot on the measured pressures must be clearly understood. Figure 4 is an idealized response curve for the steady state pressure as a function of coning frequency, ω . The response of the liquid to a coning frequency history of the type shown in Figure 3 could be unusual. The coning frequency which produces the maximum pressure is identified as ω_{max} . Two cases must be examined: (1) $\omega < \omega_{max}$ and (2) $\omega > \omega_{max}$. For (1), the liquid is momentarily forced at a frequency that is slightly faster than ω , but still slower than ω_{max} . Under these circumstances, the pressure will overshoot the anticipated steady state value. For (2), the liquid is momentarily forced at a frequency that will produce a lower pressure than the pressure associated with the steady state coning frequency. An overshoot in pressure will not occur, but the time to reach the steady state pressure may be modified. For the data in Figure 3 where $\omega < \omega_{max}$, a small overshoot in ω can yield a large,

10. Andrew Mark, "Measurements of Angular Momentum Transfer in Liquid-Filled Projectiles," BRL Technical Report ARBRL-TR-02029, November 1977. AD No. A051056.

11. Clarence W. Kitchens, Jr., and Nathan Gerber, "Prediction of Spin-Decay of Liquid-Filled Projectiles," BRL Report 1996, July 1977. AD No. A043275.

momentary over-pressure due to the steepness of the response curve. The effect of these undesirable overshoots in ω are not understood at this time, and further experiments must be conducted where the rise time, overshoot, and decay time are varied. The sensitivity of the liquid response to these effects can thereby be identified.

Pressures were measured during cone-up for two cone angles: 0.02 and 0.05deg. A single cylinder geometry (height=19.99cm, diameter=6.35cm, aspect ratio(c/a)=3.15) were tested at a $Re=5.23 \times 10^5$ (spin=83.3Hz, $\nu=0.01\text{cm}^2/\text{s}$). The amplitude of the pressure signal was determined by a spectrum analyzer (Hewlett-Packard 3582A). A data window of 2.5s with a flat top passband shape was utilized and resulted in a frequency resolution of 1.45Hz and an amplitude error of less than 1%. Unsteady data were processed using sliding time samples with overlaps of 0.5s. Such a technique implicitly assumes that the data are quasi-steady during the time interval which is processed, and such an assumption cannot be justified. However, the time to the steady state pressure response can be determined by such a procedure. The pressure data were recovered from the telemetry link and stored on an analog recorder. The data were then processed through the spectrum analyzer with the aid of a computer and a time delay generator. Raw voltage amplitudes were converted into pressures using system transfer functions with the aid of the computer.

The sequence of events during a data trial were as follows. First, the rotor would be inclined to the vertical at the proper coning angle. Second, the rotor would be allowed to spin at a steady rate for a sufficiently long period of time such that the pressures measured by the spectrum analyzer were steady. Third, with the magnetic clutch disengaged, the precessional drive was set to the proper speed. Fourth, the clutch was engaged producing impulsive coning motion. It was necessary to modify this procedure slightly since the clutch had a tendency to drift and produce a very slow rotation of the cam. A solenoid was used to hold the cam in position. The clutch would then be simultaneously engaged when the solenoid was retracted. The clutch was also used to brake the precessional drive. Data were recorded during cone-down, but have not been processed. Ordinarily, two runs would be made on both sides of ω_{max} , starting from $\omega < \omega_{max}$. After a survey in ω had been accomplished, a few values of ω were duplicated. Duplicate runs at ω_{max} were always made.

III. EXPERIMENTAL RESULTS

The pressure histories for the transducer located at a radius of 21.2mm will be reported as P/P_{ss} , where P is the instantaneous amplitude determined by the spectrum analyzer and P_{ss} is the steady state pressure. The first plotted value of the pressure ratio is at 1.25s, which corresponds to the middle of the 2.5s data window. Successive determinations of amplitude are at 0.5s intervals as previously discussed.

A. Coning Angle of 0.02deg.

Figures 5a-e provide pressure ratio histories for five different coning frequencies. When $\omega < \omega_{max} = 3.918\text{Hz}$, overshoots in P/P_{ss} did occur, as expected. For $\omega > \omega_{max}$, overshoots did not occur. In general the time to

achieve a steady response is several seconds, and oscillations about $P/P_{ss}=1$ persist even for long times. The data in Figure 5a indicate an overshoot to 1.8, then a relaxation below $P/P_{ss}=1$, and then a continuing oscillatory behavior. The data in Figure 5b exhibit an overshoot to only 1.2 at 3-4s, and then a relaxation to $P/P_{ss}=1$. Data in Figure 5c did not exhibit an overshoot. Two runs were made since $\omega=\omega_{max}$. The runs were not made in immediate succession, but displayed consistent trends. Data within Figure 5d did not exhibit an overshoot. Data within Figure 5e also did not exhibit an overshoot, but an unusual excursion in P/P_{ss} occurred between 1.25 and 3.25s.

B. Coning Angle of 0.05deg

Data for this case are presented within Figures 6a-e. As before, overshoots in P/P_{ss} occur for $\omega < \omega_{max}$. Figure 6a shows an overshoot of 1.8, and a relaxation below $P/P_{ss}=1$. The two runs show consistent trends. Data within Figure 6b show an overshoot to 1.2 and a decay to $P/P_{ss}=1$. Small differences exist between the two runs. If the coning frequency histories for these runs are carefully examined (refer to Appendix A), it is seen that the frequency overshoot for Run 7 exceeded ω_{max} , and this condition will yield a lower pressure. The data in Figure 6c does not have an overshoot, but a sizeable amplitude difference exists during the 6-17s timeframe. Again, a careful examination of the coning frequency history for these runs shows that Run 6 was slightly slower in frequency than Run 3 during this time period. A slightly faster coning frequency for $\omega=\omega_{max}$ will produce a reduction in pressure. The data in Figures 6d and 6e do not exhibit overshoots in P/P_{ss} or other anomalous behavior.

IV. DETERMINATION OF THE CONE-UP TIME

The pressure histories provide a direct measurement of the time required by the liquid to adjust to the motion of the cylinder. Since P/P_{ss} adjusts to the final steady state response in an asymptotic form, the time at which $P/P_{ss}=0.95$ was arbitrarily selected as the cone-up time. In practice, each pressure history was examined for the time at which $|1-P/P_{ss}|>0.05$. The presence of overshoots and oscillatory behavior in the pressure histories will affect the determination of cone-up times, but the simple criterion of $|1-P/P_{ss}|>0.05$ was applied. The cone-up times were correlated with the steady state value of C_p (Figures 7 and 8). The correlations have a linear trend.

Some of the times do not correlate well, for example Run 2 for the 0.02deg case and Runs 1, 2, 7, and 9 for the 0.05deg case. All of these runs were pressure histories with overshoots, and a better correlation would be produced if slightly shorter cone-up times could be justified for these cases. An overshoot in ω would produce higher pressures and slightly longer cone-up times, as determined by the selected criterion for cone-up time. Since the overshoot effects are not understood at this time, however, it seems to be unreasonable to modify the cone-up criterion in an attempt to simply produce better correlations of the data. The results indicate that longer cone-up times are required for larger C_p values. If C_p is reduced by modification of operational parameters such as Re , coning amplitude, or aspect ratio, then the cone-up times will also be reduced. Conversely, if C_p is increased, the cone-up times will also increase.

Since the experiments of Whiting have shown nonlinear effects for C_p , the selected coning angles for these initial cone-up experiments were quite small, especially by projectile standards. Figure 9 shows a comparison between data by Whiting and "steady state" responses from the cone-up experiments. Since C_p is scaled by the coning angle, data from experiments at different coning angles should fall within a narrow band if linear behavior exists. Departures from this band should be considered as nonlinear. The data by Whiting exhibit nonlinear trends only for the larger values of C_p . Data from the cone-up experiments are consistent within themselves, but are outside the band established by the Whiting data. All of the data indicate a maximum C_p for $\omega/\dot{\phi}$ approximately equal to 0.046. This indicates that parameters which may tend to shift the location of the ω_{max} , principally Reynolds number and aspect ratio, are consistent between the various experiments. It simply appears that the C_p amplitudes for the cone-up data are lower. Transfer functions for the pressure transducer/telemetry systems were independently determined, but were essentially identical to those used by Whiting. It is possible that nonlinear effects have been introduced by the impulsive disturbance during cone-up. These effects once introduced may not dissipate. Due to the nature of the experiments and the limited operating time of the battery operated telemetry system, very long time records were not taken during the cone-up experiments.

A crude estimate of the cone-up time for linear pressure responses can be made. Assume

$$P_{total} = P_{ss} + P_{transient} \quad , \quad (1)$$

where $P_{transient}$ is the unsteady pressure response during cone-up. Now P_{ss} can be represented as a superposition using the natural modes of oscillation (eigenfrequencies) and a proper set of eigenfunctions. $P_{transient}$ could be expressed in the same fashion. For $\omega = \omega_{max}$ (the case of exact resonance), $P_{transient}$ will be dominated by the eigenfrequency equal to $\omega_{max}/\dot{\phi}$.

$$P_{transient} = \sum A_m e^{i\dot{\phi}\tau_m t} \quad , \quad (2)$$

This eigenfrequency is complex and the imaginary part (τ_I) will control the response or decay time for $P_{transient}$. The viscous corrected eigenfrequency can be computed by methods established by Wedemeyer¹², where an order of magnitude approximation will yield $\tau_I = 0(\text{Re}^{\frac{1}{2}})$. The cone-up time, T_c , for coning angles of linear pressure response is,

$$T_c = \text{Re}^{\frac{1}{2}}/\dot{\phi} \quad (3)$$

12. E.H. Wedemeyer, "Viscous Corrections to Stewartson's Stability Criterion," BRL Report 1325, June 1966. AD No. 489687.

For Run 3 or Run 6 of the 0.02deg case, the viscous eigenfrequency is $\tau_m = 0.467 + i 1.35 \times 10^{-3}$ and $T_c = 1.42$ s. These estimates of cone-up time should correspond to the e-folding time or the time for P/P_{ss} to reach 0.623. From Figure 5c, $P/P_{ss} = 0.623$ occurs at approximately one second, which roughly corresponds to the estimated values for T_c . Further experiments to determine the dependence of T_c on the coning angle should be made.

If the cone-up time of a liquid is several seconds, then the simulation of a liquid payload on-board a projectile must account for spin-up from rest and cone-up. Kitchens and Gerber have shown that a substantial exchange of angular momentum can occur in-bore for a liquid-filled projectile¹¹. Kitchens and Gerber defined L/L_0 as the ratio of the instantaneous angular momentum of the liquid to the angular momentum that the liquid would have as a solid body rotating at the launch spin rate. Within Ref. 11 for $Re = 3.32 \times 10^3$ and 1.70×10^6 , computed values for L/L_0 at muzzle exit were 0.20 and 0.03, respectively. Yawing motion for the projectile is initiated in an impulsive fashion upon launch, but spin-up is in progress during travel down the bore. There is also a very small amplitude yawing motion during travel down the bore (ballotting). The amplitude of this in-bore motion is probably similar to the present set of experiments. This in-bore motion may produce an unusual set of initial conditions for the free-flight motion. There is, however, an overlap of the spin-up and cone-up regimes. An estimate for the spin-up time can be found in Ref. 8: $T_s = (c/a) Re^{1/2} / \phi$. Since spin-up is an exponential process, T_s represents the characteristic or e-folding time for a cylinder when $Re \gg 1$. Since both T_s and T_c are $O(Re^{1/2})$, the unsteady processes for cone-up and spin-up must be considered simultaneously for a liquid-filled projectile. For the present experiments, $T_s = 4.3$ s (as labeled on Figures 7 and 8).

V. CONCLUSIONS

A series of experiments were performed to determine the response time of a spinning liquid to impulsive coning motion. For the aspect ratio and Reynolds number tested, the cone-up times were several seconds in duration. Linear correlations were developed for the cone-up times and steady state pressure coefficients.

Coning angles were restricted to very small angles (0.02 and 0.05deg) so that the pressure data could be easily interpreted without the presence of gross nonlinear effects. It is probable that yaw levels typical of real projectiles will modify the conclusions that have been reached by this initial investigation, but an engineering estimate for the cone-up time is $Re^{1/2} / \phi$.

VI. ACKNOWLEDGEMENT

The authors wish to thank Dr. C. H. Murphy for suggestion of these experiments and for valuable discussions of the data and its import.

REFERENCES

1. K. Stewartson, "The Stability of a Spinning Top Containing Liquid," Journal of Fluid Mechanics, Vol. 5, 1959, pp. 557-592.
2. Andrew Mark and William H. Mermagen, "Measurement of Spin Decay and Instability of Liquid-Filled Projectiles Via Telemetry," BRL Memorandum Report 2333, October 1973. AD No. 771919.
3. B. G. Karpov, J. T. Frasier, and W. P. D'Amico, "Experimental Studies with a Liquid-Filled Gyroscope," Journal of Spacecraft and Rockets, Vol. 9, No. 3, March 1972, pp. 220-222.
4. K. D. Aldridge, "Experimental Verification of the Inertial Oscillations of a Fluid in a Cylinder During Spin-Up," BRL Contract Report 273, November 1975. AD No. A018797.
5. K. D. Aldridge, "Axisymmetric Inertial Oscillations of a Fluid in a Cylindrical Cavity During Spin-Up from Rest," Geophys. Astrophys. Fluid Dynamics, Vol. 8, 1977, pp. 279-301.
6. K. D. Aldridge and S. Stergiopoulos, "Ringdown of Coupled Inertial Waves in a Rotating Fluid," presented at the Canadian Geophysical Union Meeting, Calgary, Alberta, May 1981.
7. Richard D. Whiting, "An Experimental Study of Forced Asymmetric Oscillations in a Rotating Liquid-Filled Cylinder," BRL Technical Report ARBRL-TR-02376, October 1981. AD No. A107948.
8. H. P. Greenspan, The Theory of Rotating Fluids, Cambridge Press, 1969.
9. W. E. Scott and W. P. D'Amico, "Amplitude-Dependent Behavior of a Liquid-Filled Gyroscope," Journal of Fluid Mechanics, Vol. 3, 1966, pp. 17-26.
10. Andrew Mark, "Measurements of Angular Momentum Transfer in Liquid-Filled Projectiles," BRL Technical Report ARBRL-TR-02029, November 1977. AD No. A051056.
11. Clarence W. Kitchens, Jr., and Nathan Gerber, "Prediction of Spin-Decay of Liquid-Filled Projectiles," BRL Report 1996, July 1977. AD No. A043275.
12. E. H. Wedemeyer, "Viscous Corrections to Stewartson's Stability Criterion," BRL Report 1325, June 1966. AD No. 489687.

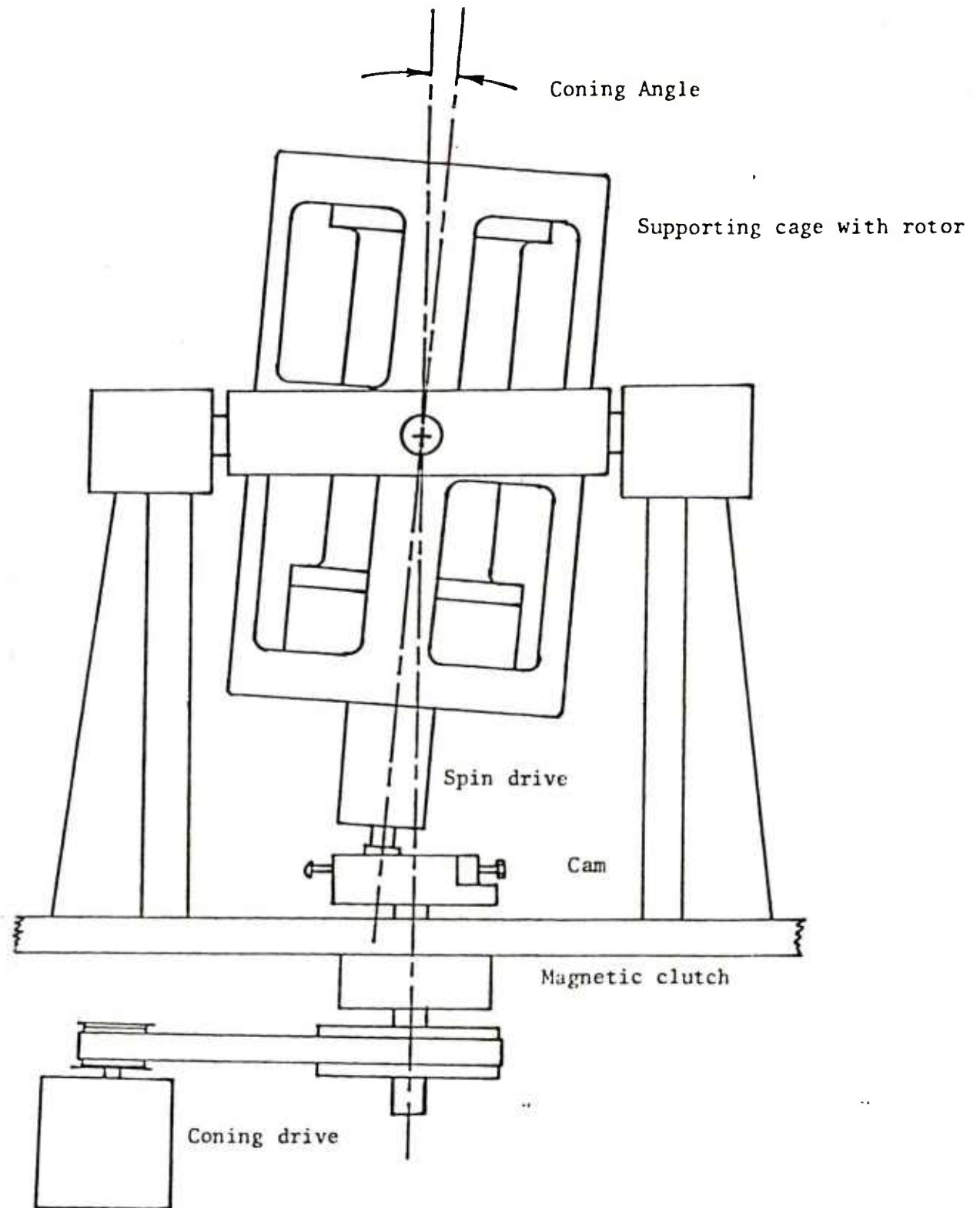
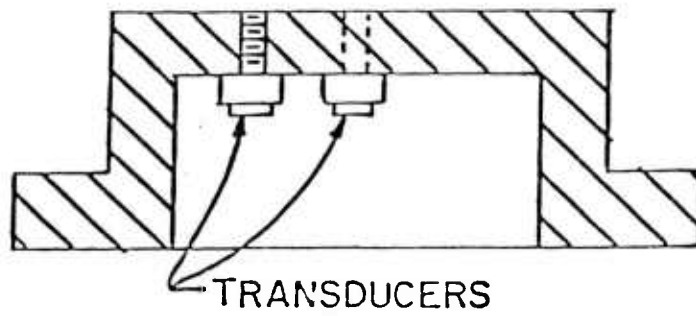
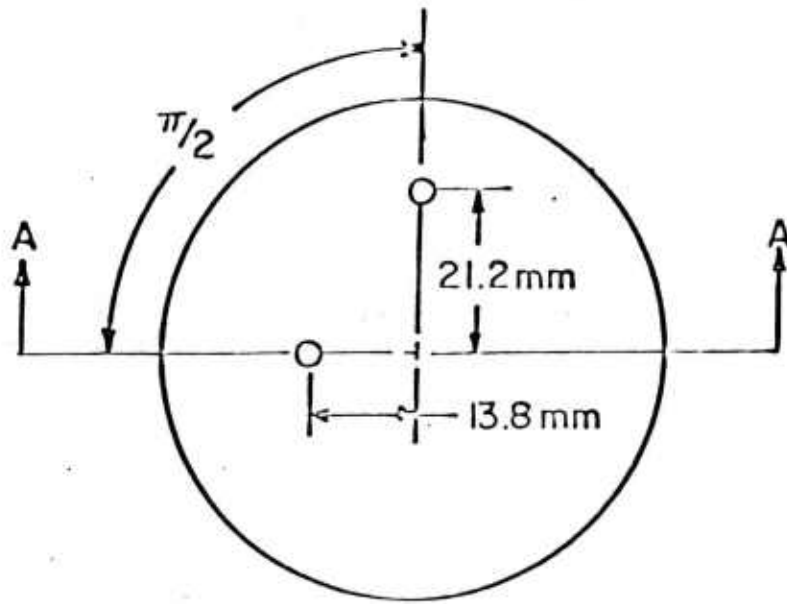

Figure 1. Gimbal Case



SECTION A-A

Figure 2. Placement of Pressure Transducers

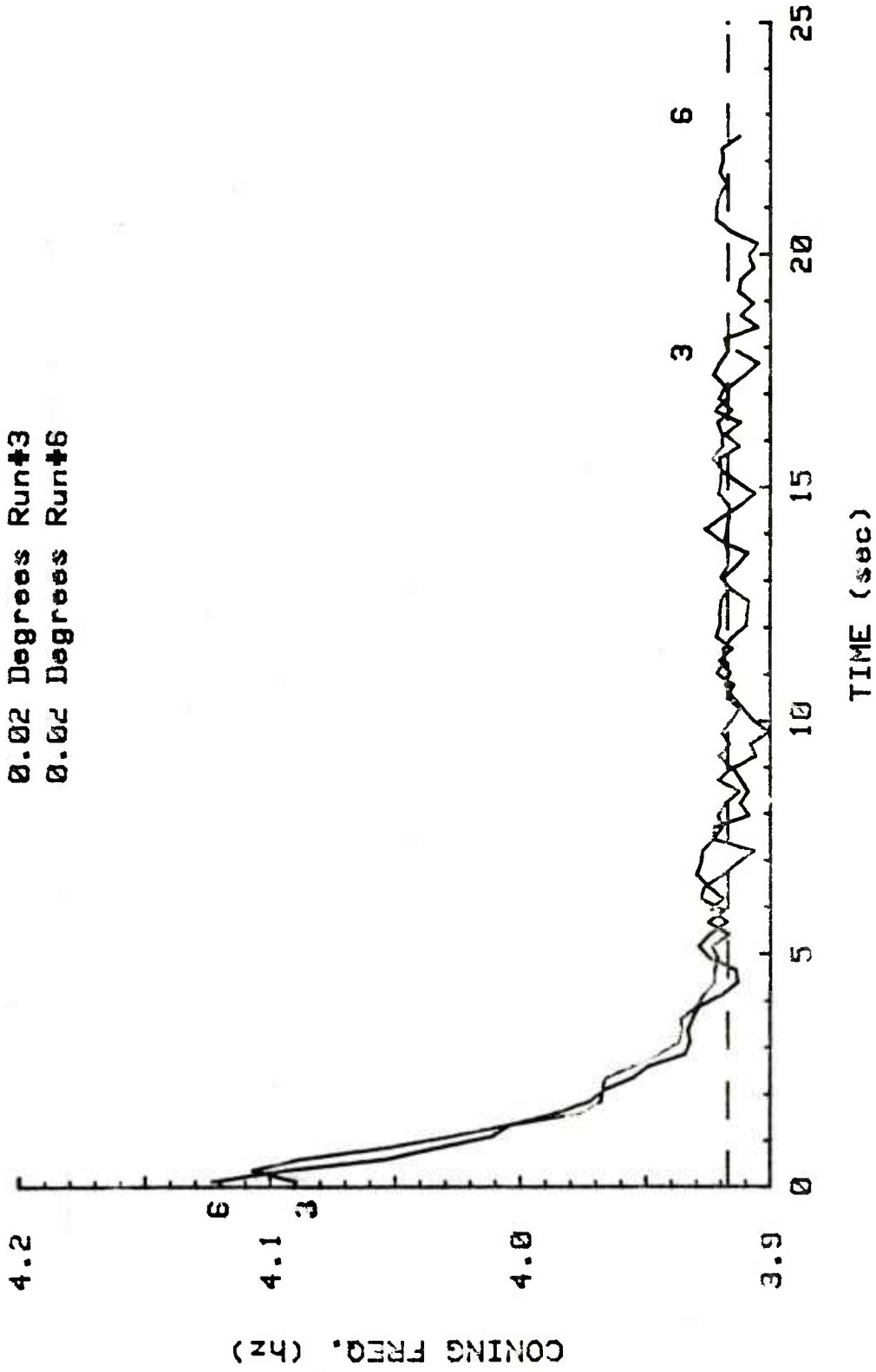

Figure 3. Typical Coning Frequency Histories

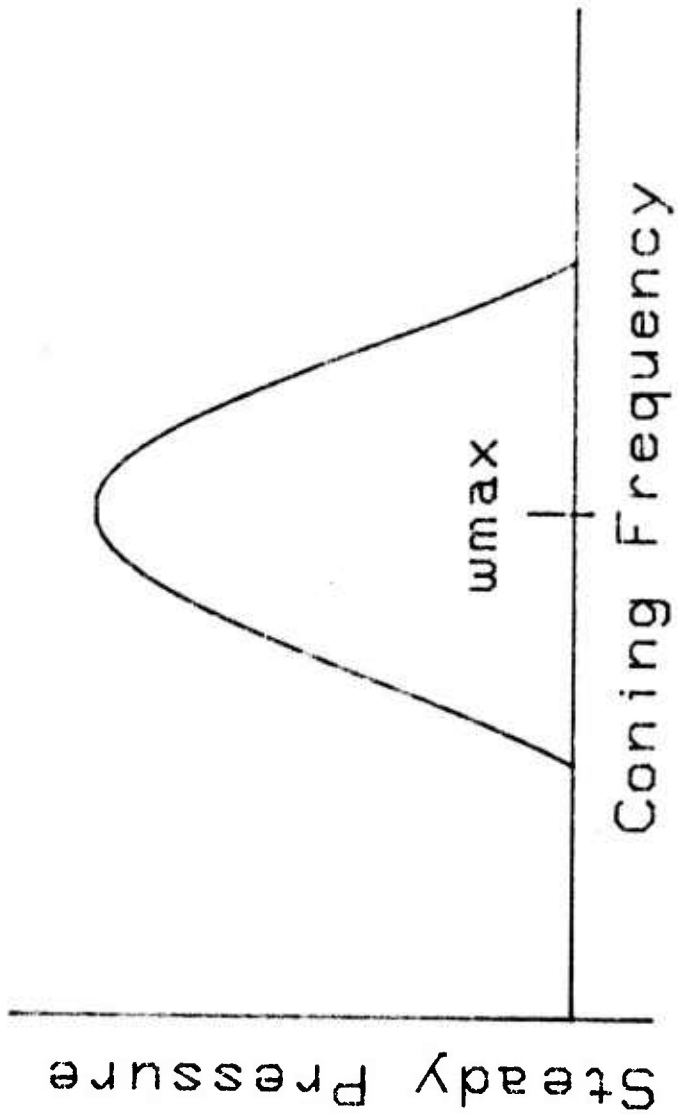

Figure 4. Pressure Response Curve

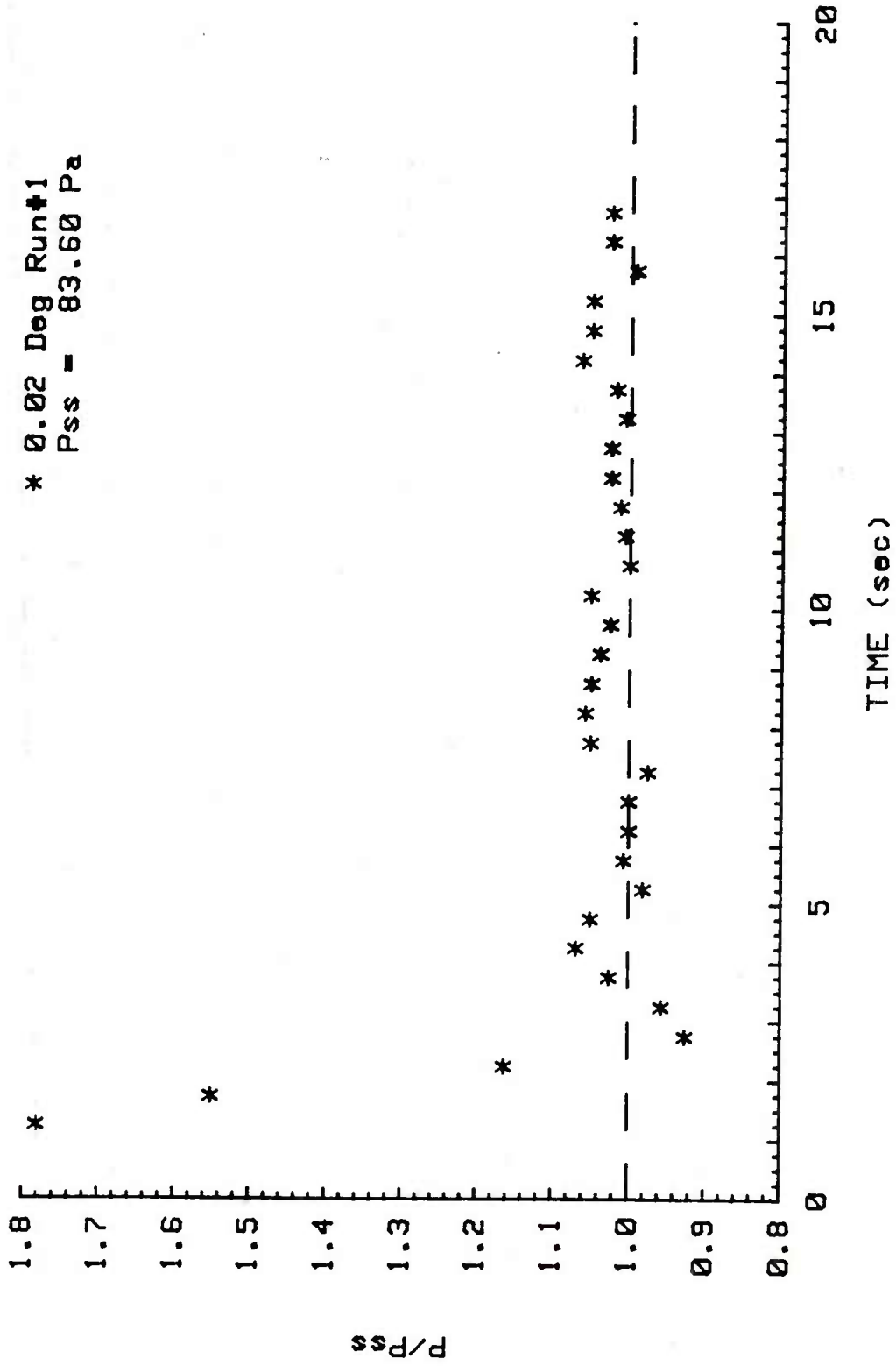

Figure 5a. Pressure versus Time for $\omega=3.5\text{Hz}$ and $\epsilon=0.02\text{deg}$

* 0.02 Deg Run#2
 Pss = 209.30 Pa

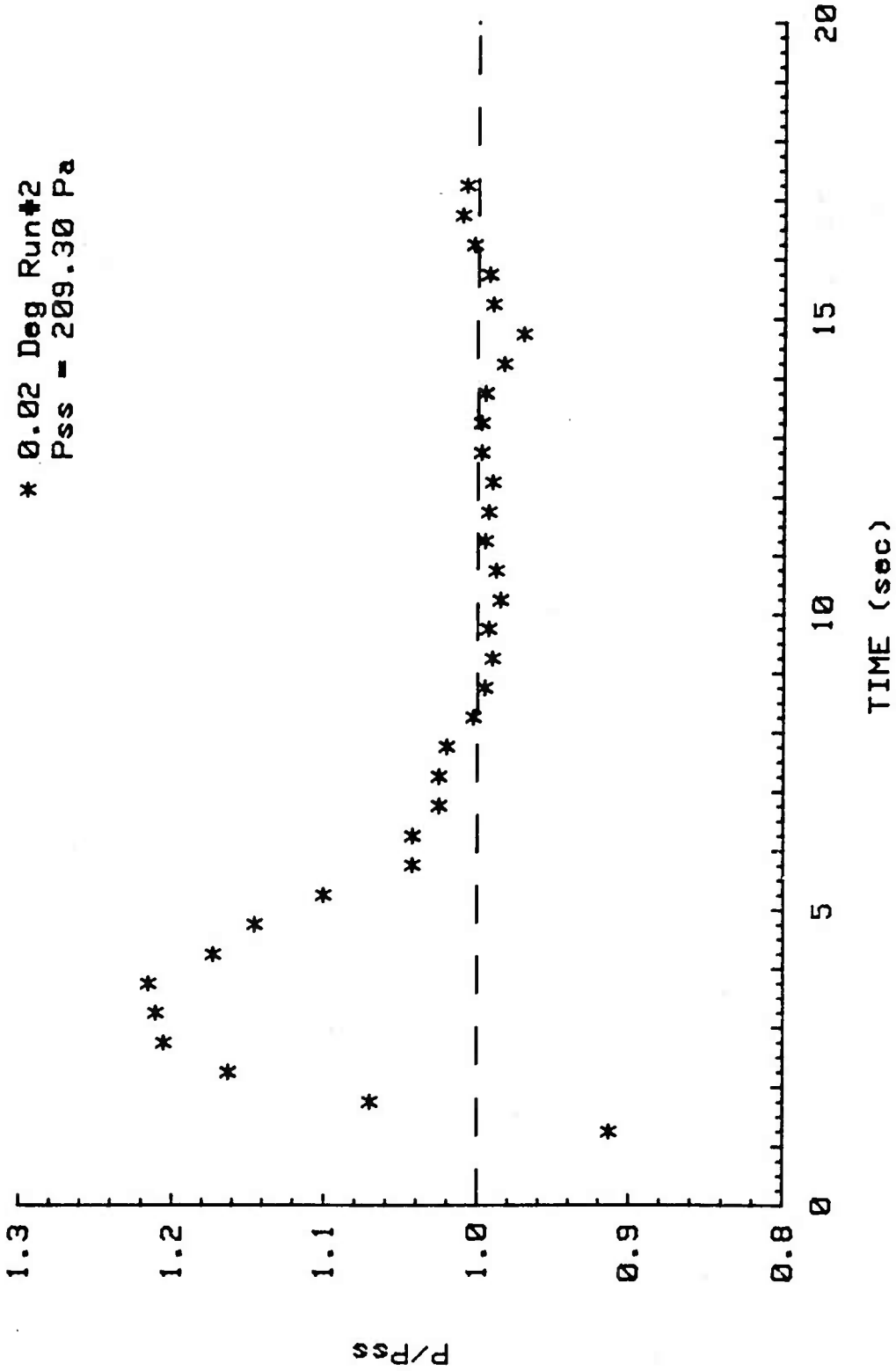

Figure 5b. Pressure versus Time for $\omega=3.75\text{Hz}$ and $\epsilon=0.02\text{deg}$

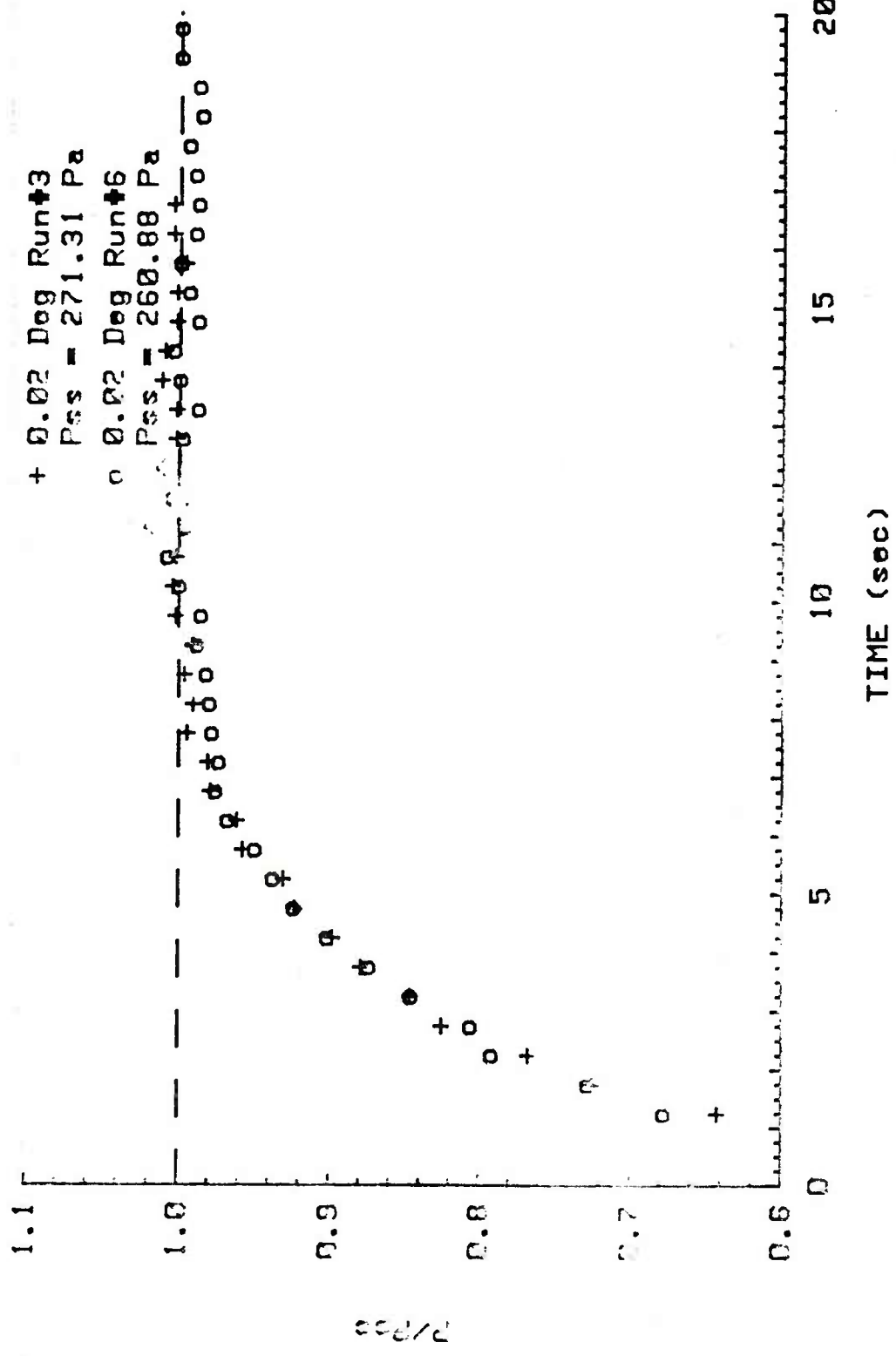

Figure 5c. Pressure versus Time for $\omega=3.918\text{Hz}$ and $\epsilon=0.02\text{deg}$

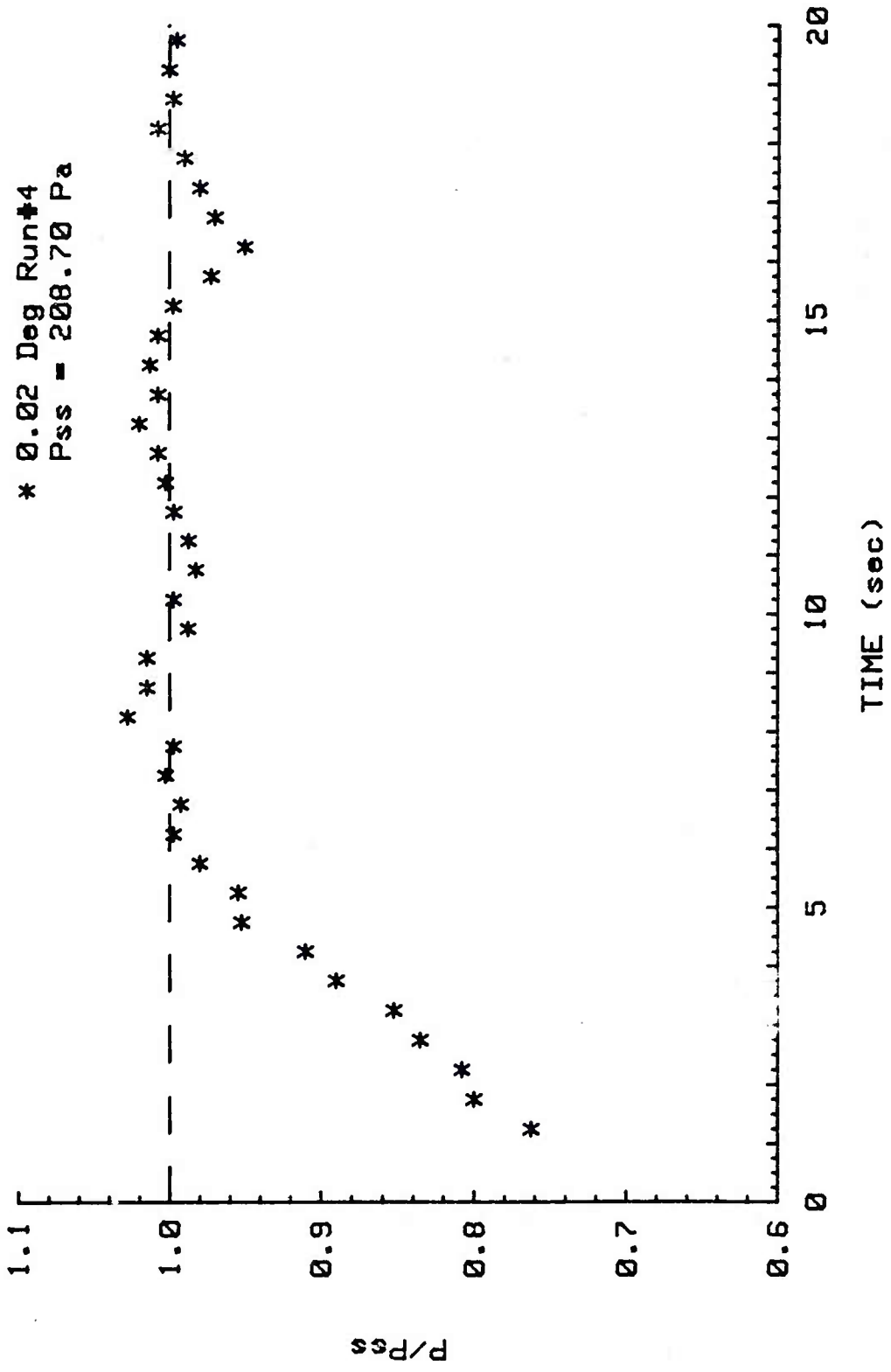

Figure 5d. Pressure versus Time for $\omega=4.0\text{Hz}$ and $\epsilon=0.02\text{deg}$

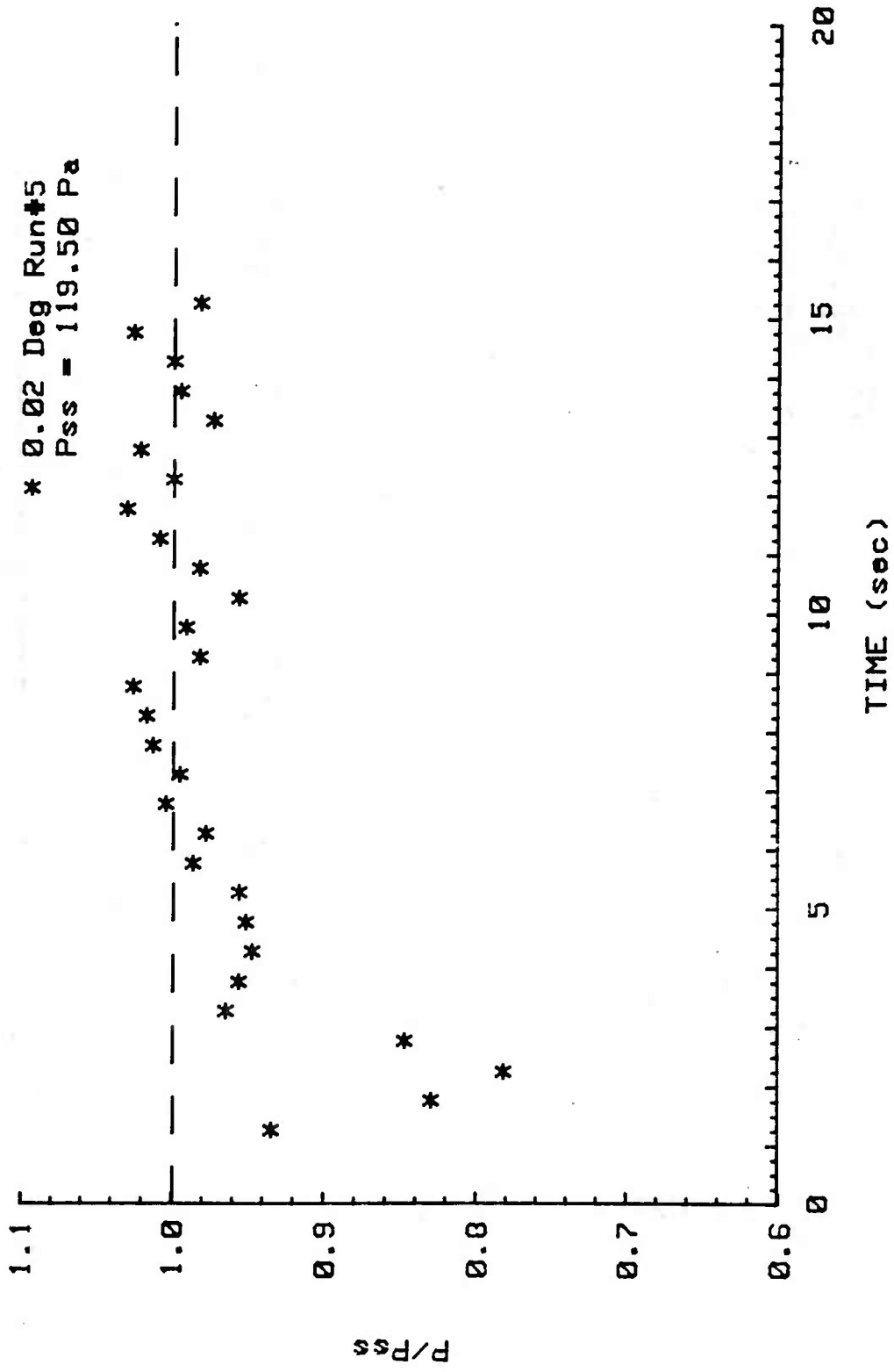

Figure 5e. Pressure versus Time for $\omega=4.168\text{Hz}$ and $\epsilon=0.02\text{deg}$

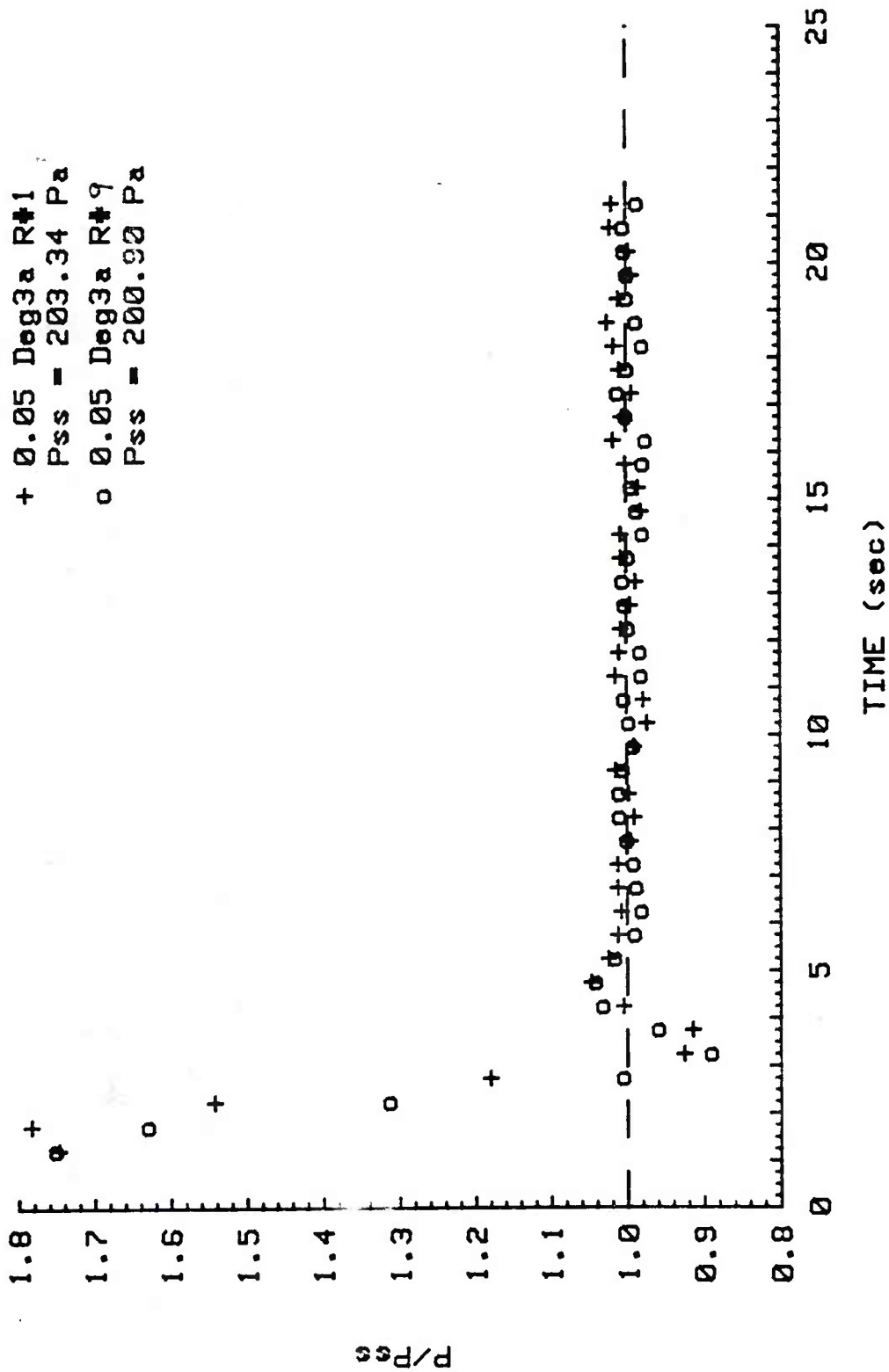

Figure 6a. Pressure versus Time for $\omega=3.5\text{Hz}$ and $\epsilon=0.05\text{deg}$

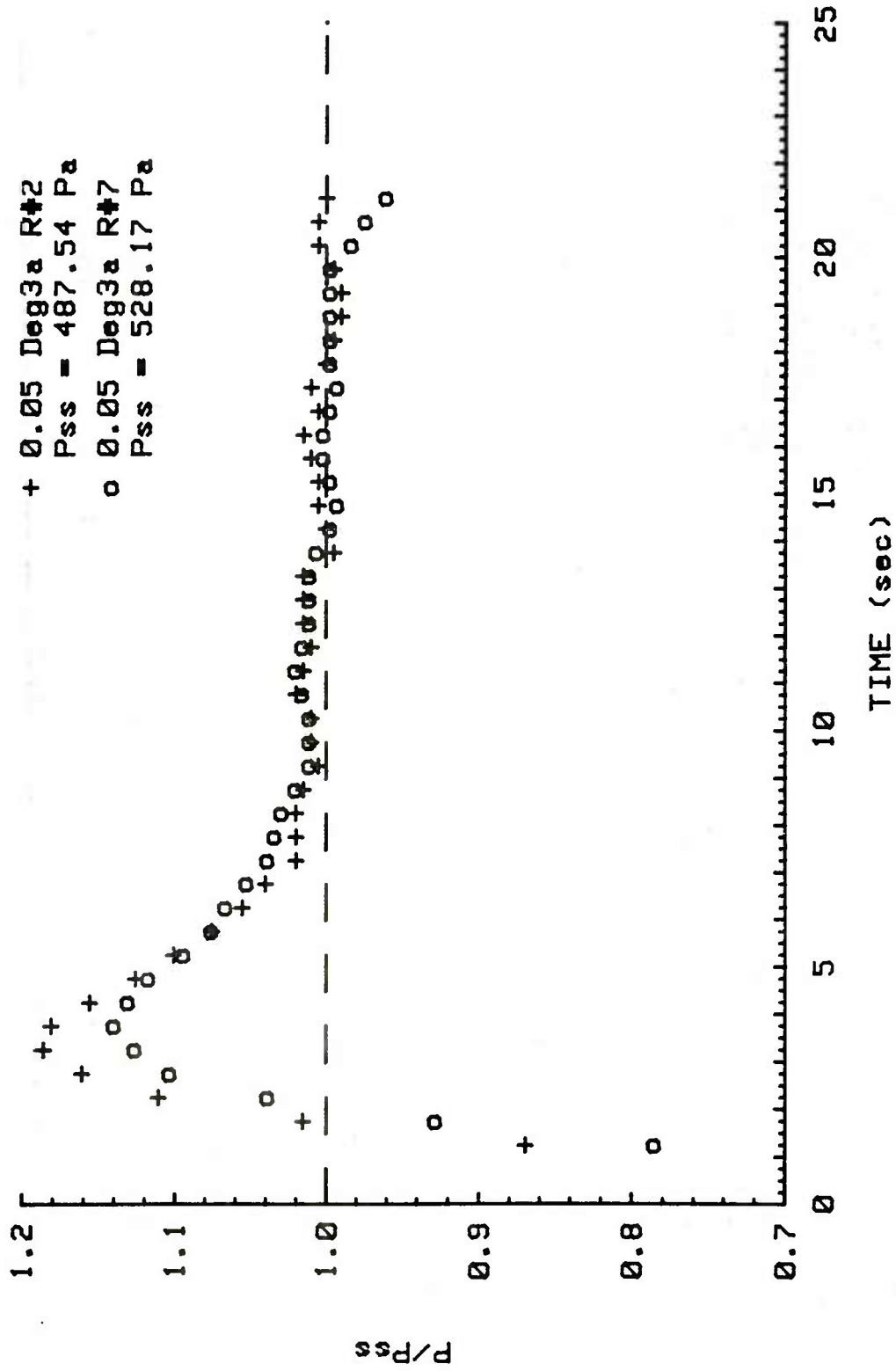

Figure 6b. Pressure versus Time for $\omega=3.75\text{Hz}$ and $\epsilon=0.05\text{deg}$

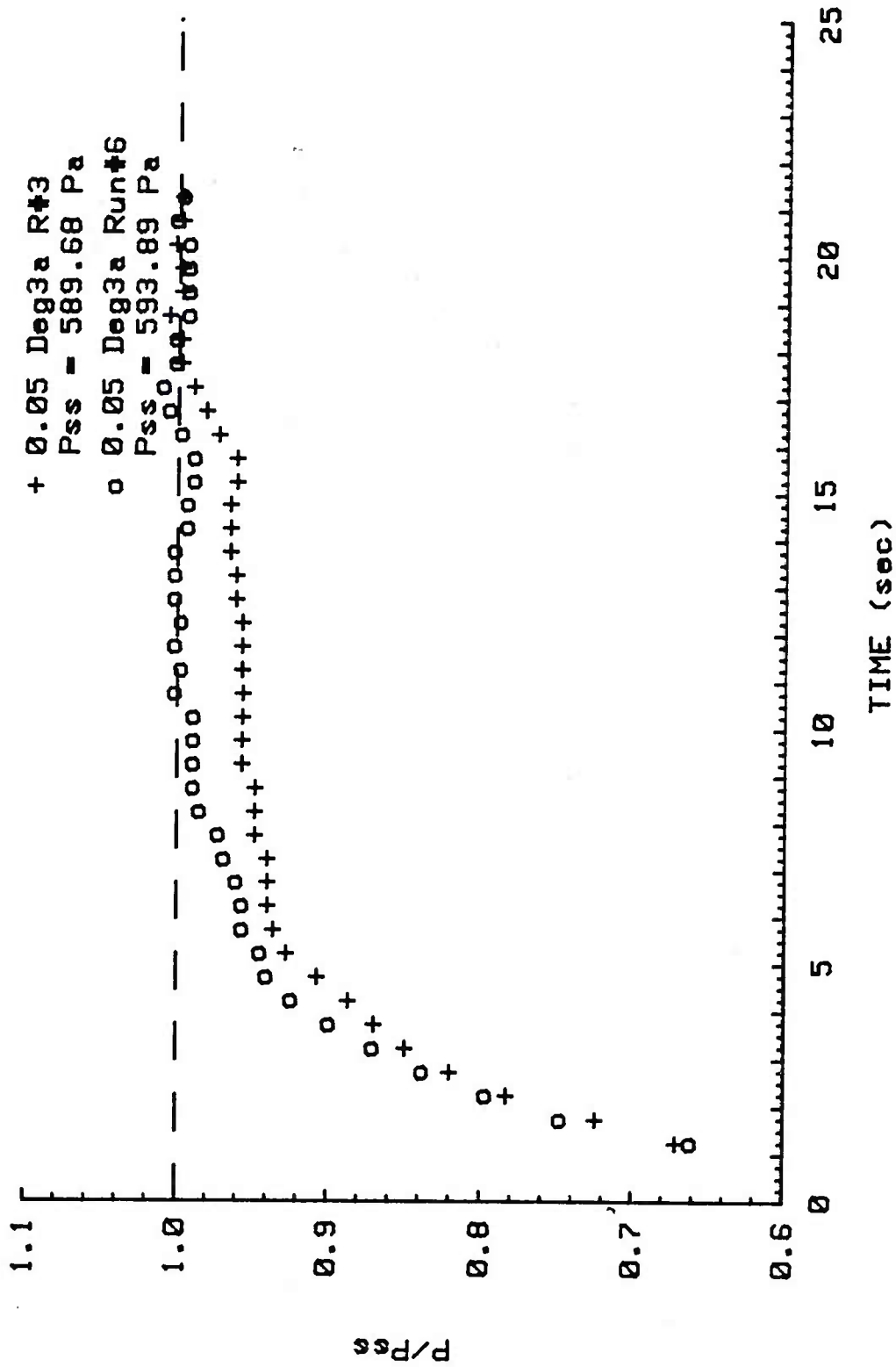

Figure 6c. Pressure versus Time for $\omega=3.918\text{Hz}$ and $\epsilon=0.05\text{deg}$

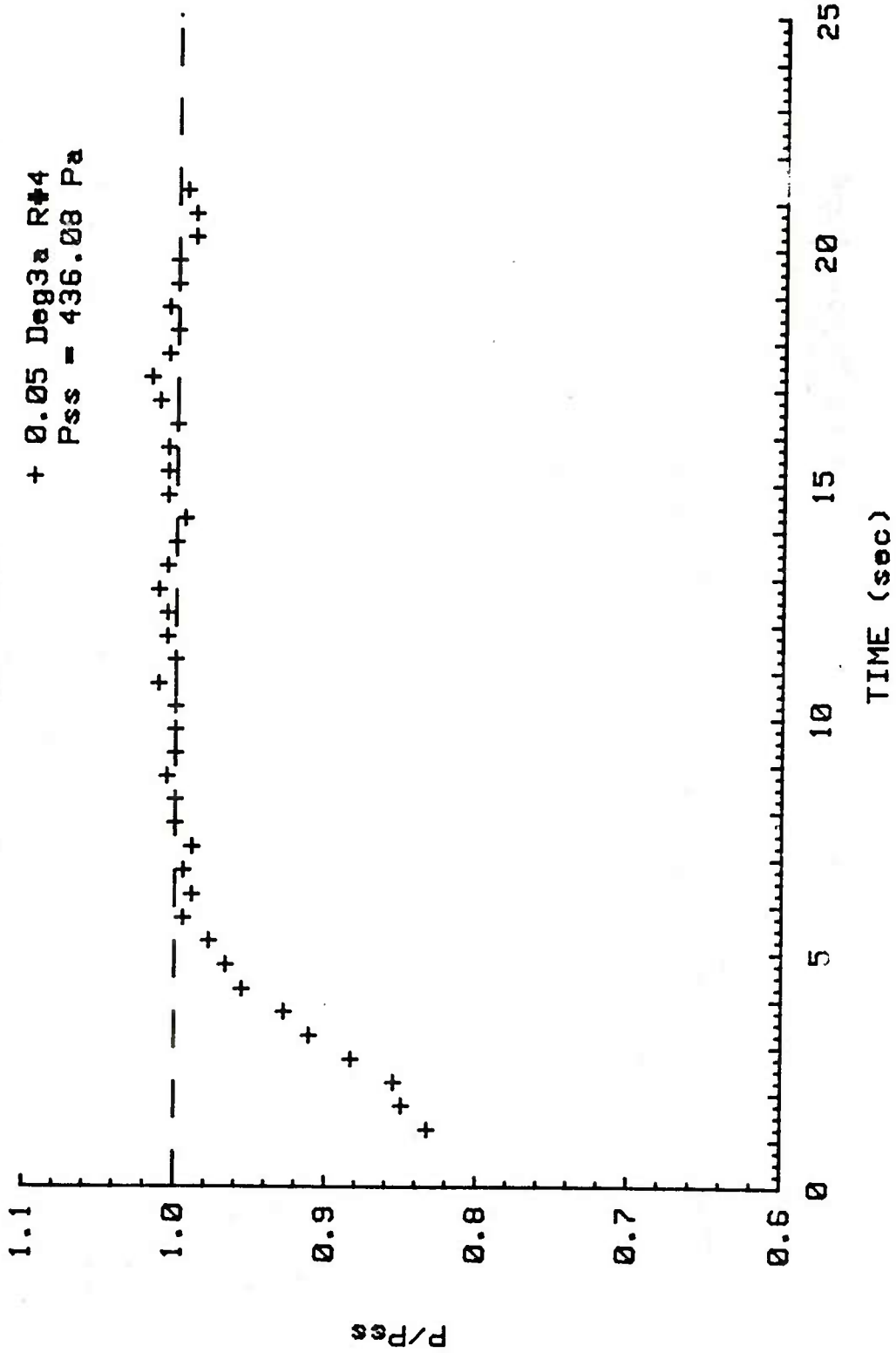

Figure 6d. Pressure versus Time for $\omega=4.0\text{Hz}$ and $c=0.05\text{deg}$

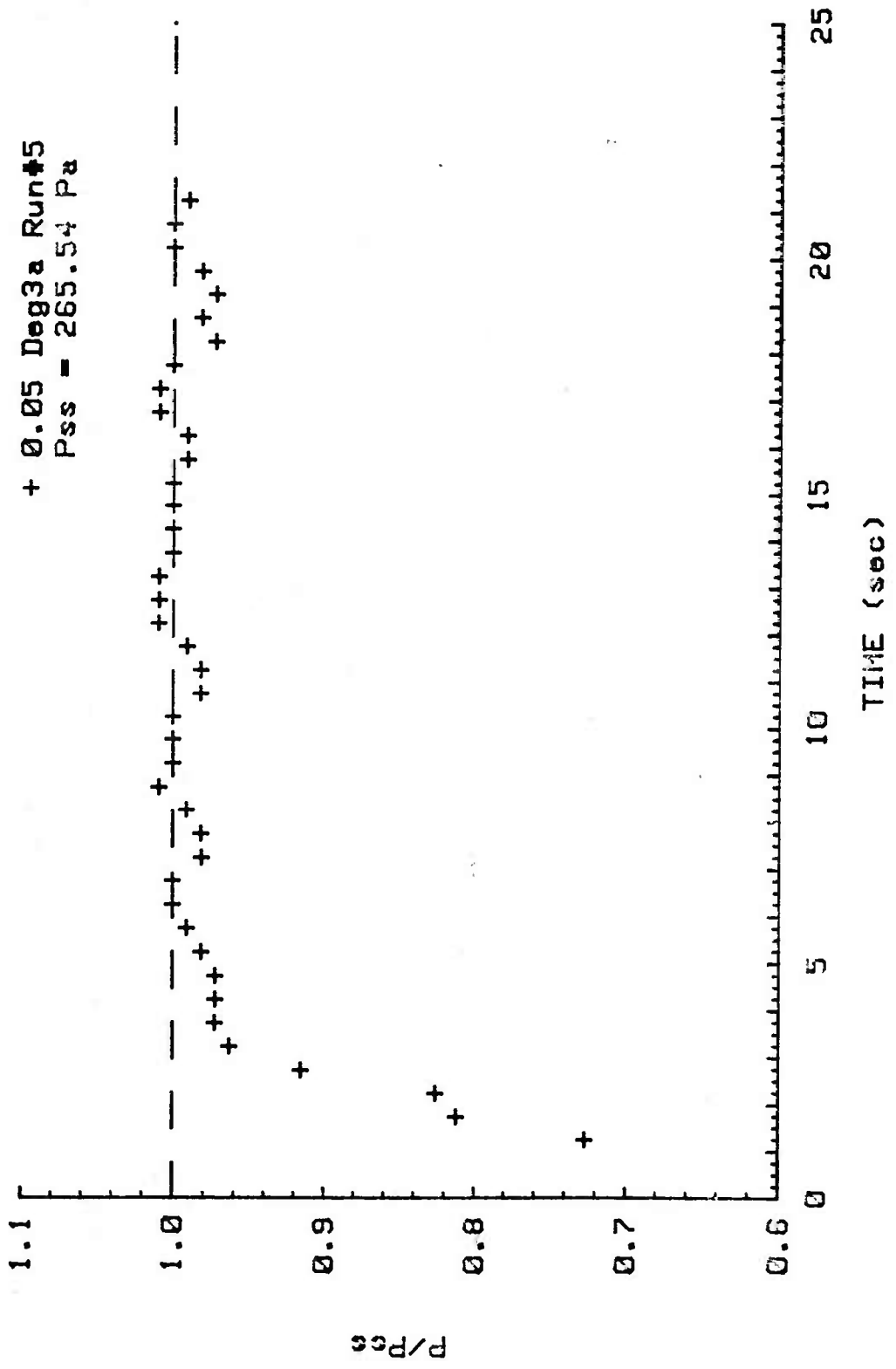

Figure 6e. Pressure versus Time for $\omega=4.168\text{Hz}$ and $\epsilon=0.05\text{deg}$

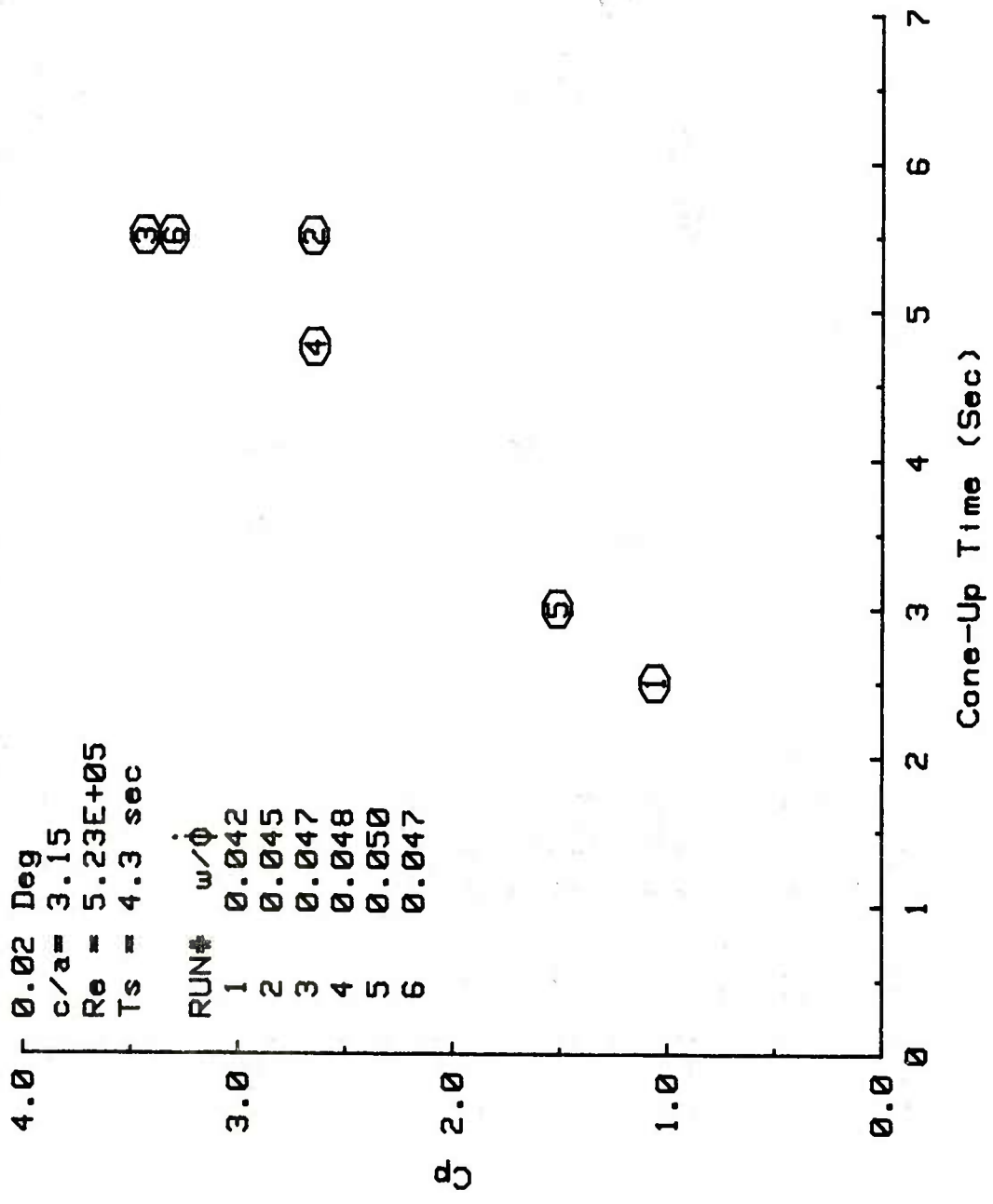

Figure 7. Cone-Up Time versus Pressure Coefficient -- 0.02deg

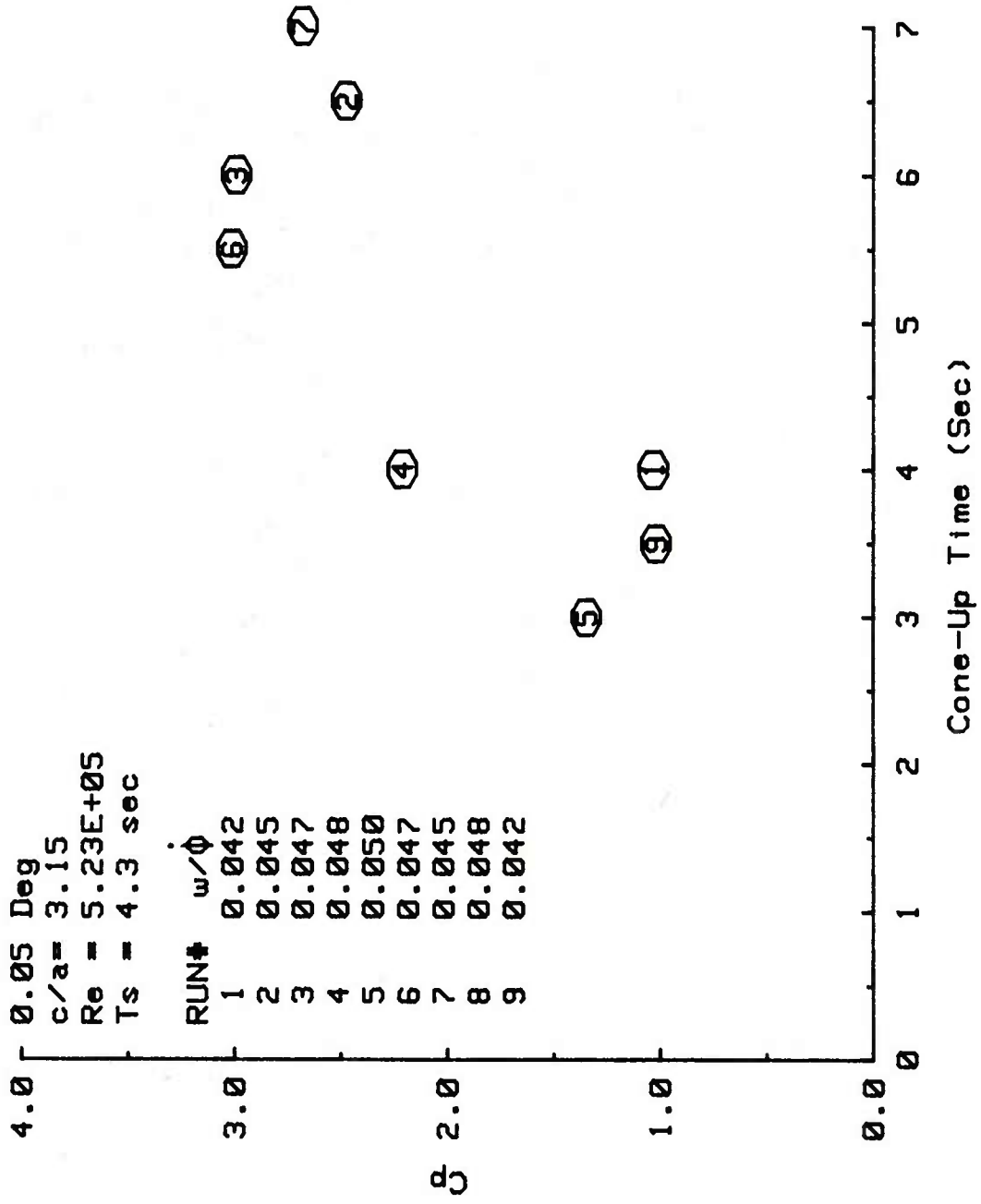

Figure 8. Cone-Up Time versus Pressure Coefficient -- 0.05deg

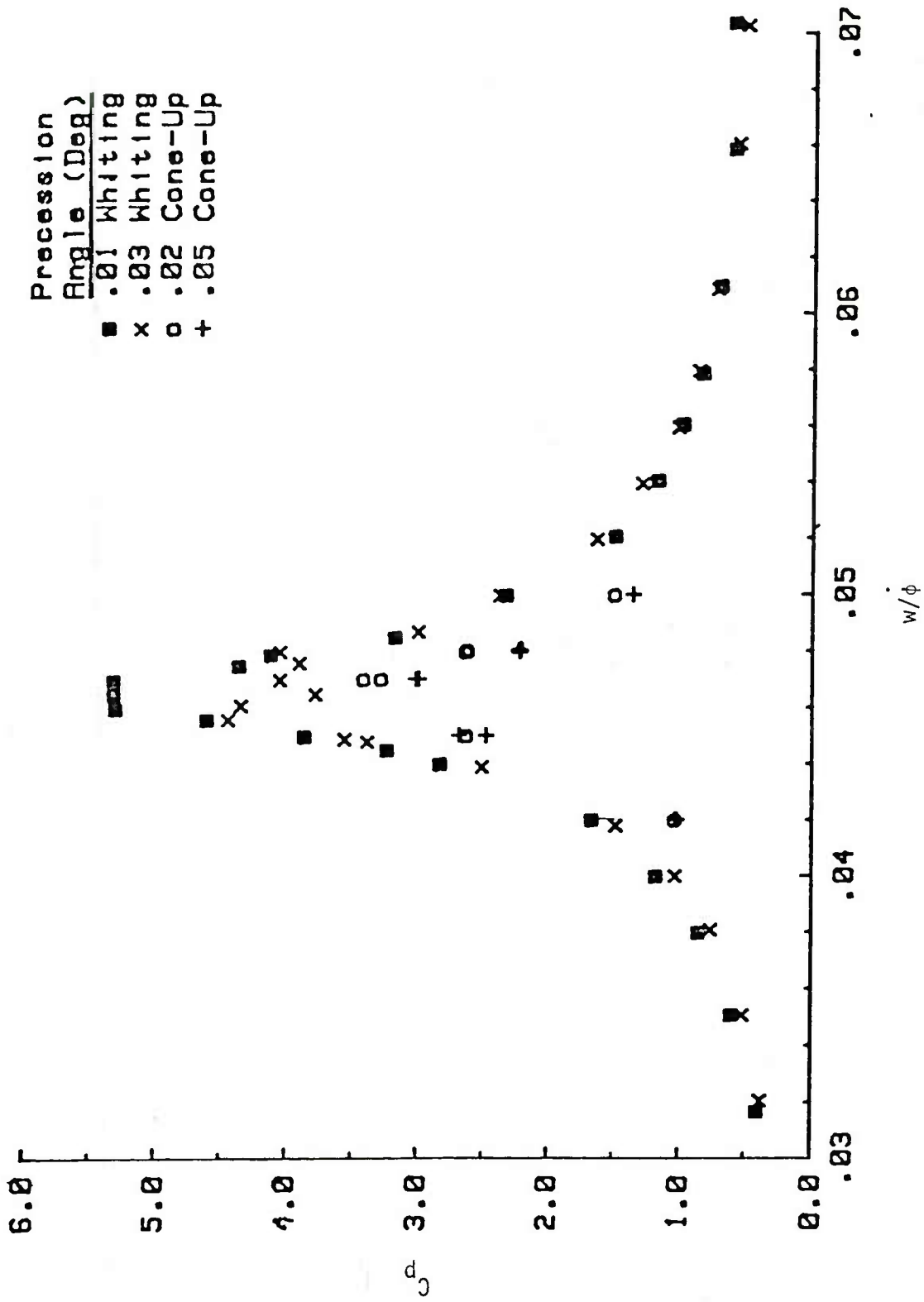

Figure 9. Comparison of Pressure Coefficients

APPENDIX A
Coning Frequency Histories

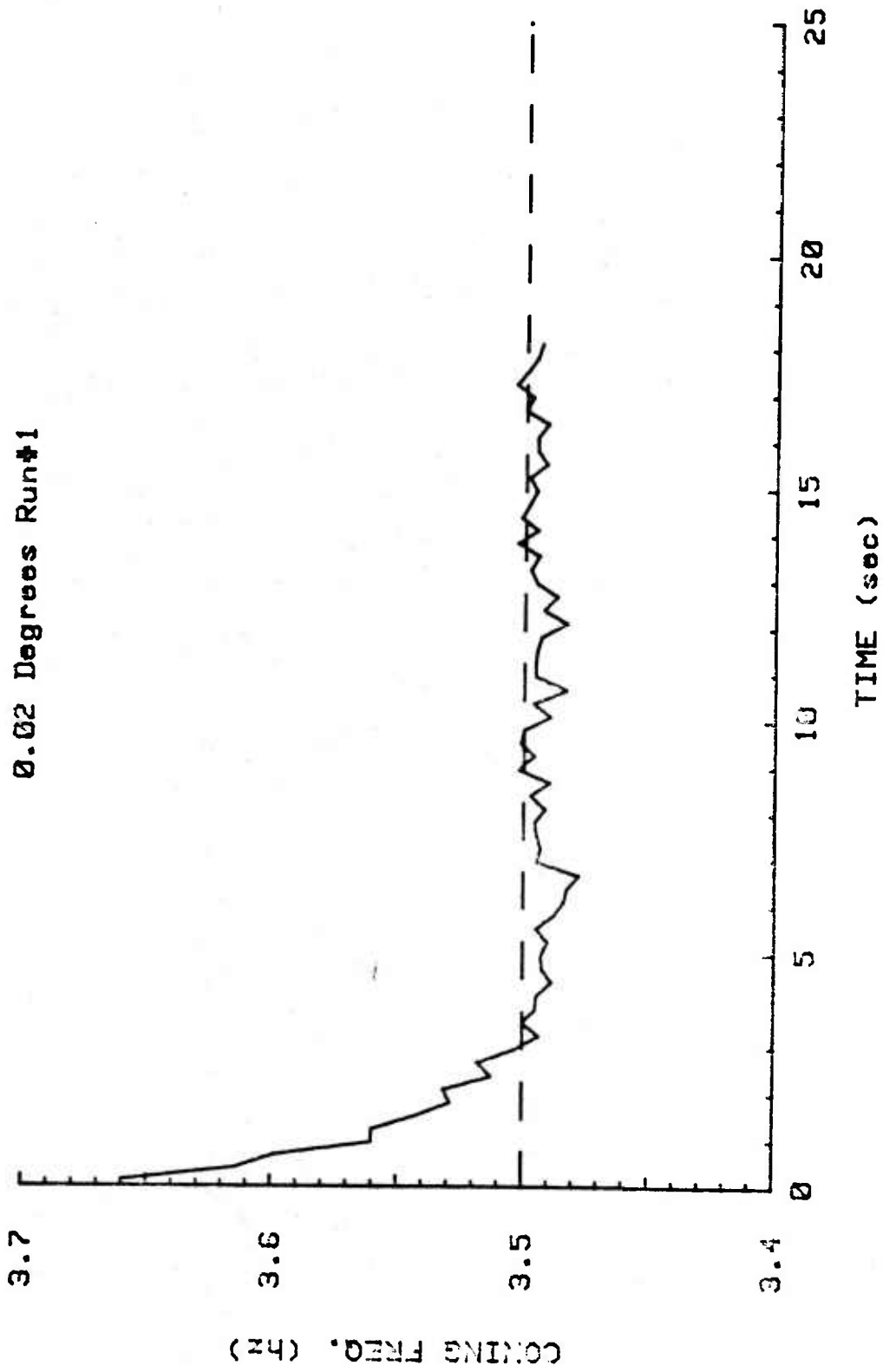

Figure A1. Coning Frequency History: 0.02 Degrees Run #1

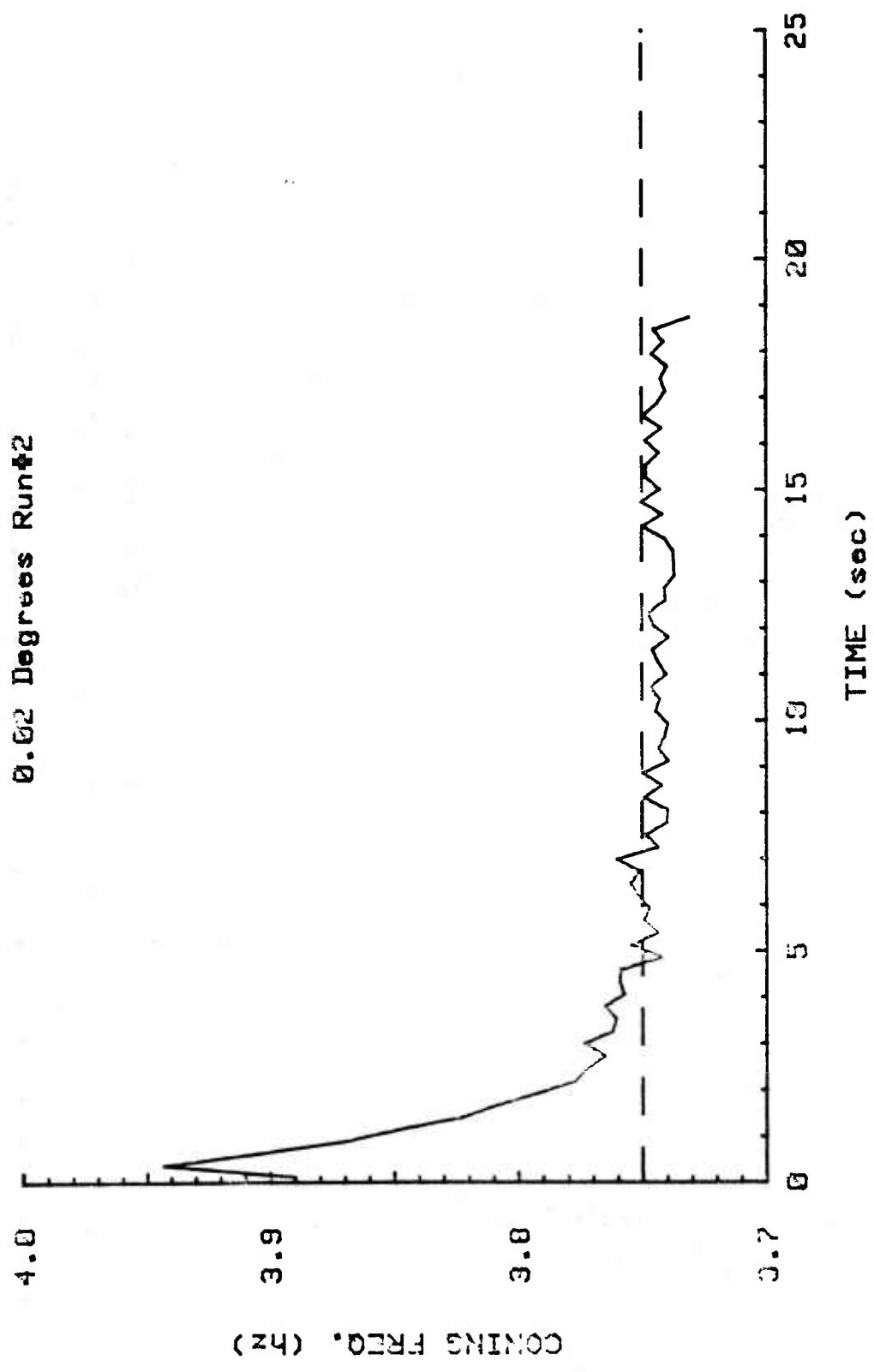

Figure A2. Coning Frequency History: 0.02 Degrees Run #2

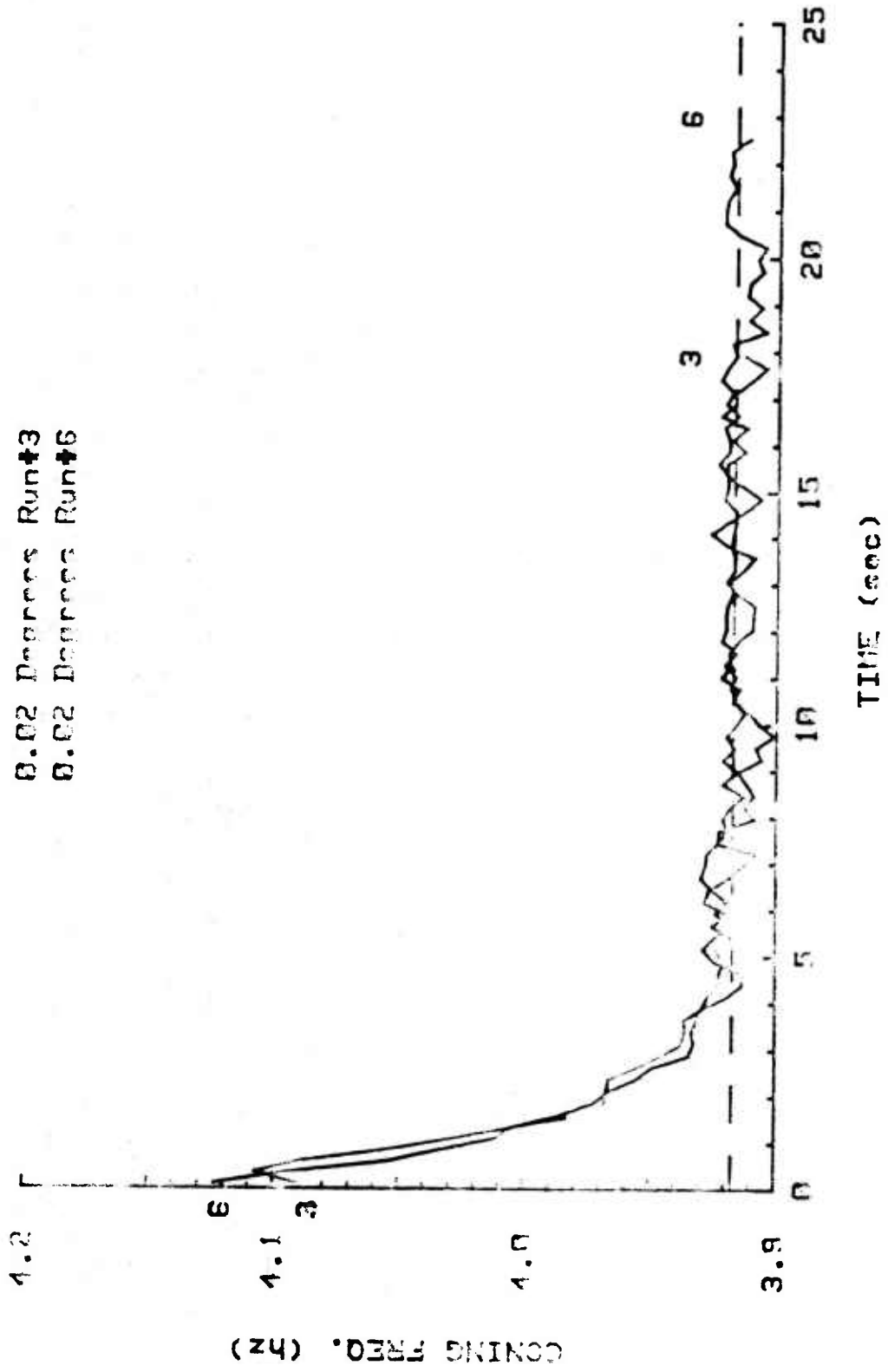

Figure A3. Coning Frequency History: 0.02 Degrees Runs #3 and #6

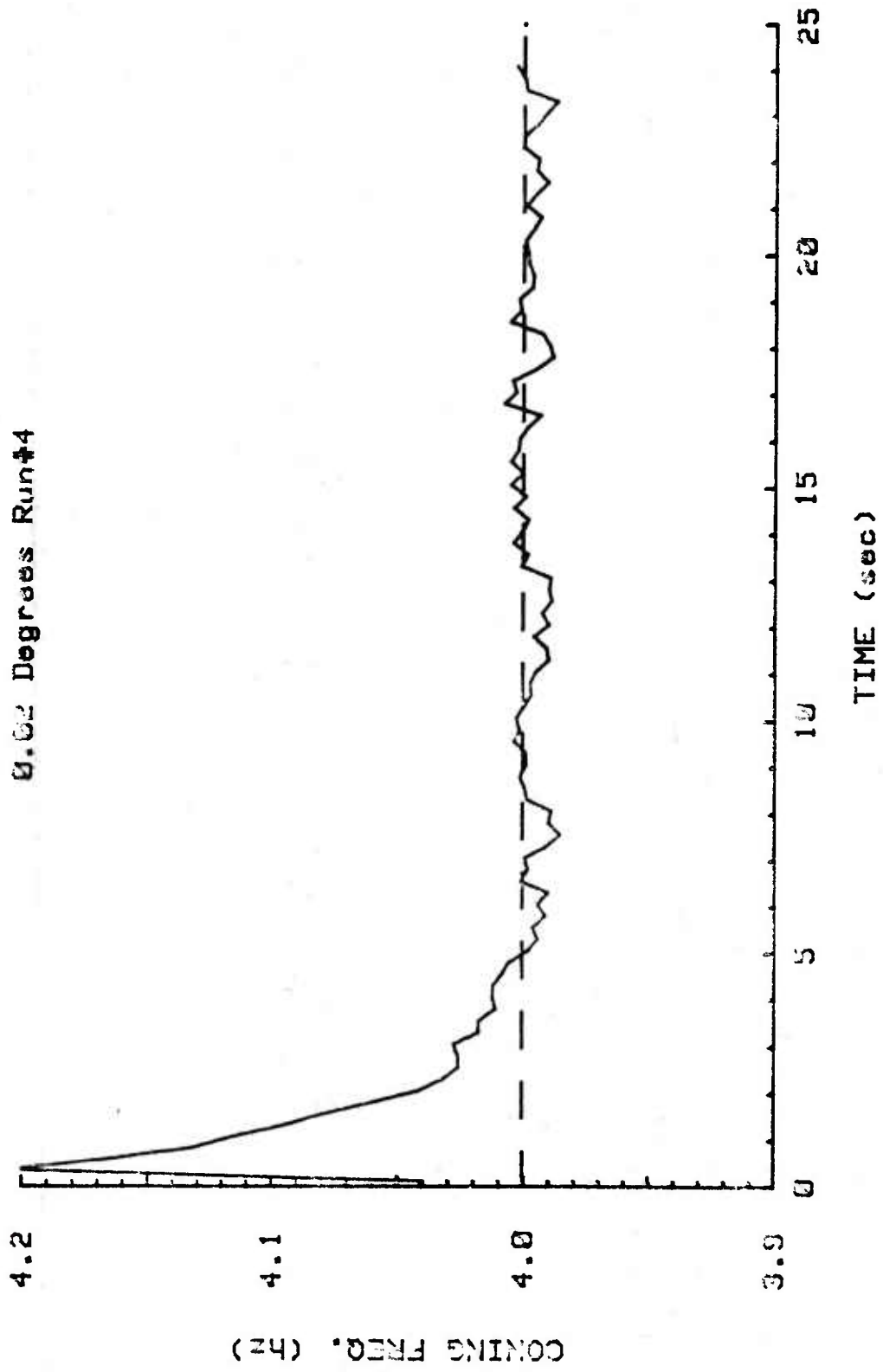

Figure A4. Coning Frequency History: 0.02 Degrees Run #4

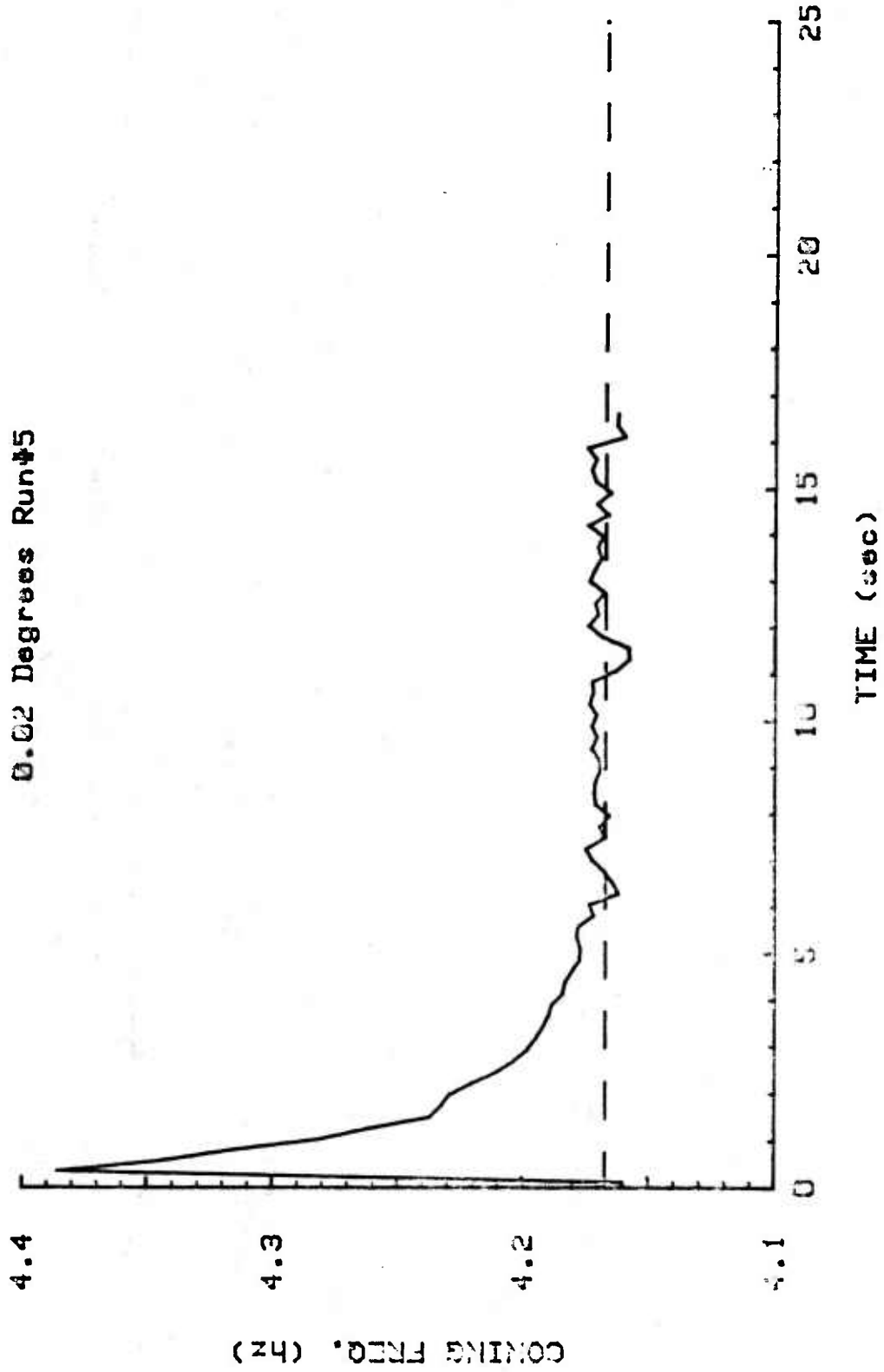

Figure A5. Coning Frequency History: 0.02 Degrees Run #5

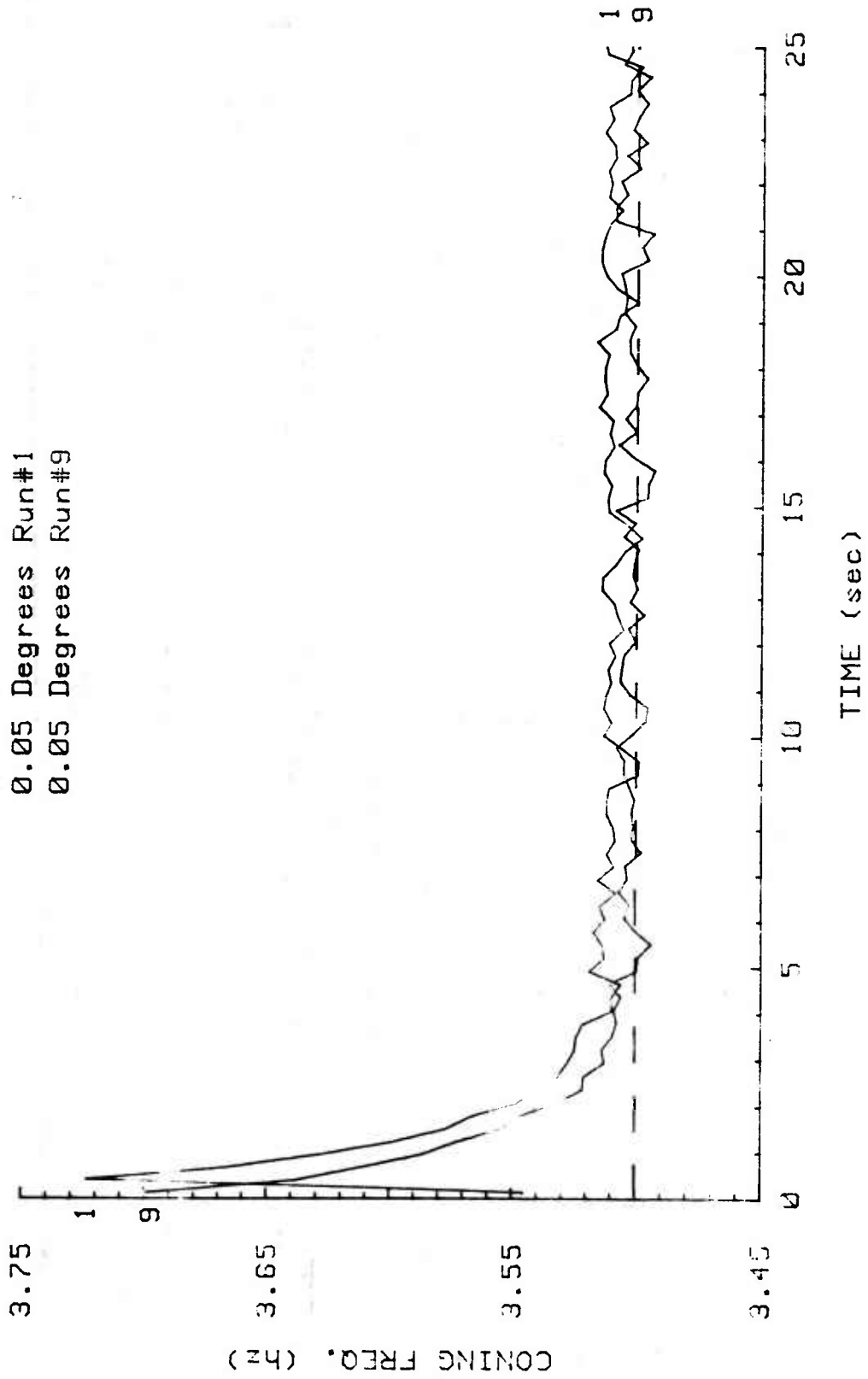

Figure A6. Coning Frequency History: 0.05 Degrees Runs #1 and #9

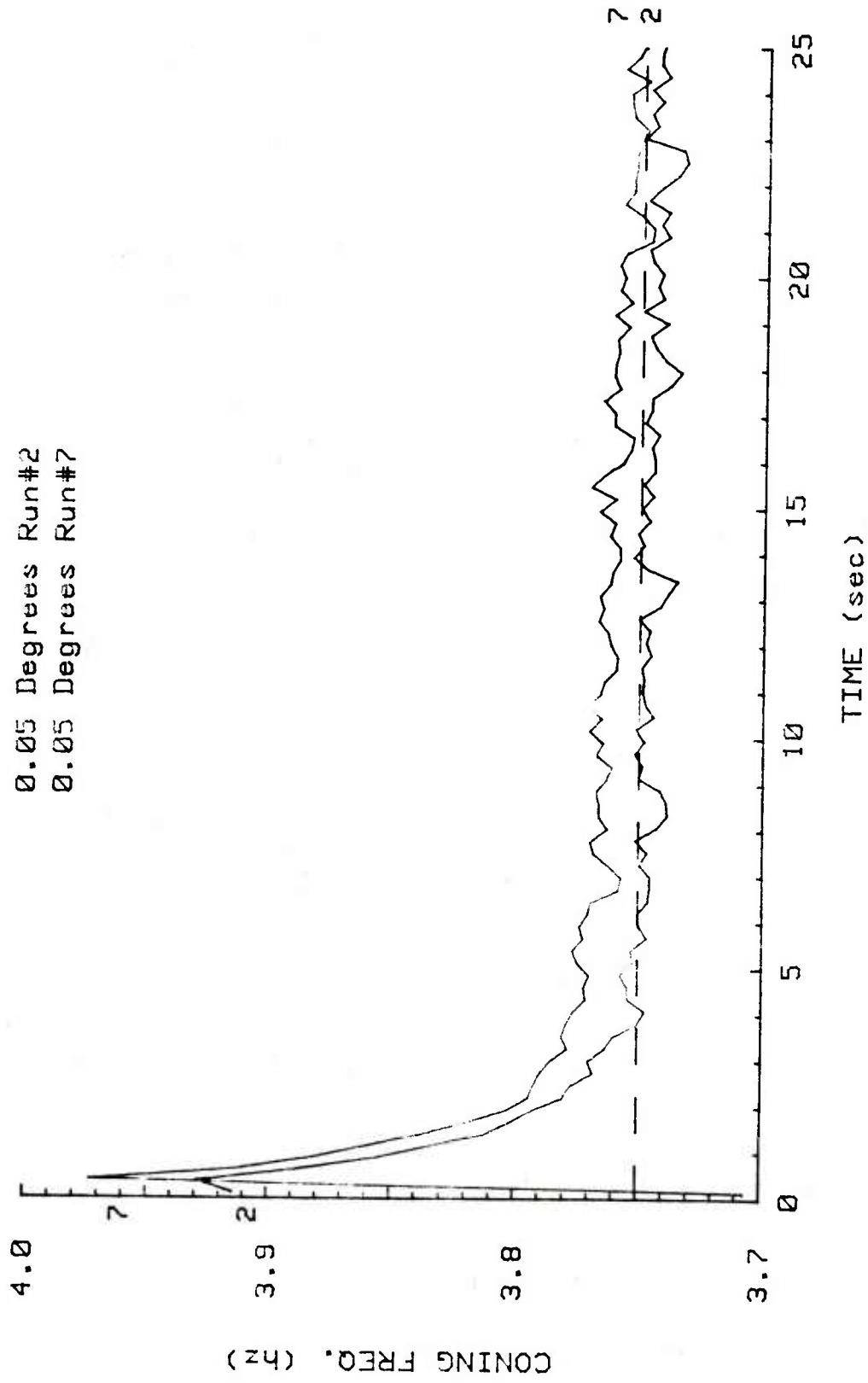

Figure A7. Coning Frequency History: 0.05 Degrees Runs #2 and #7

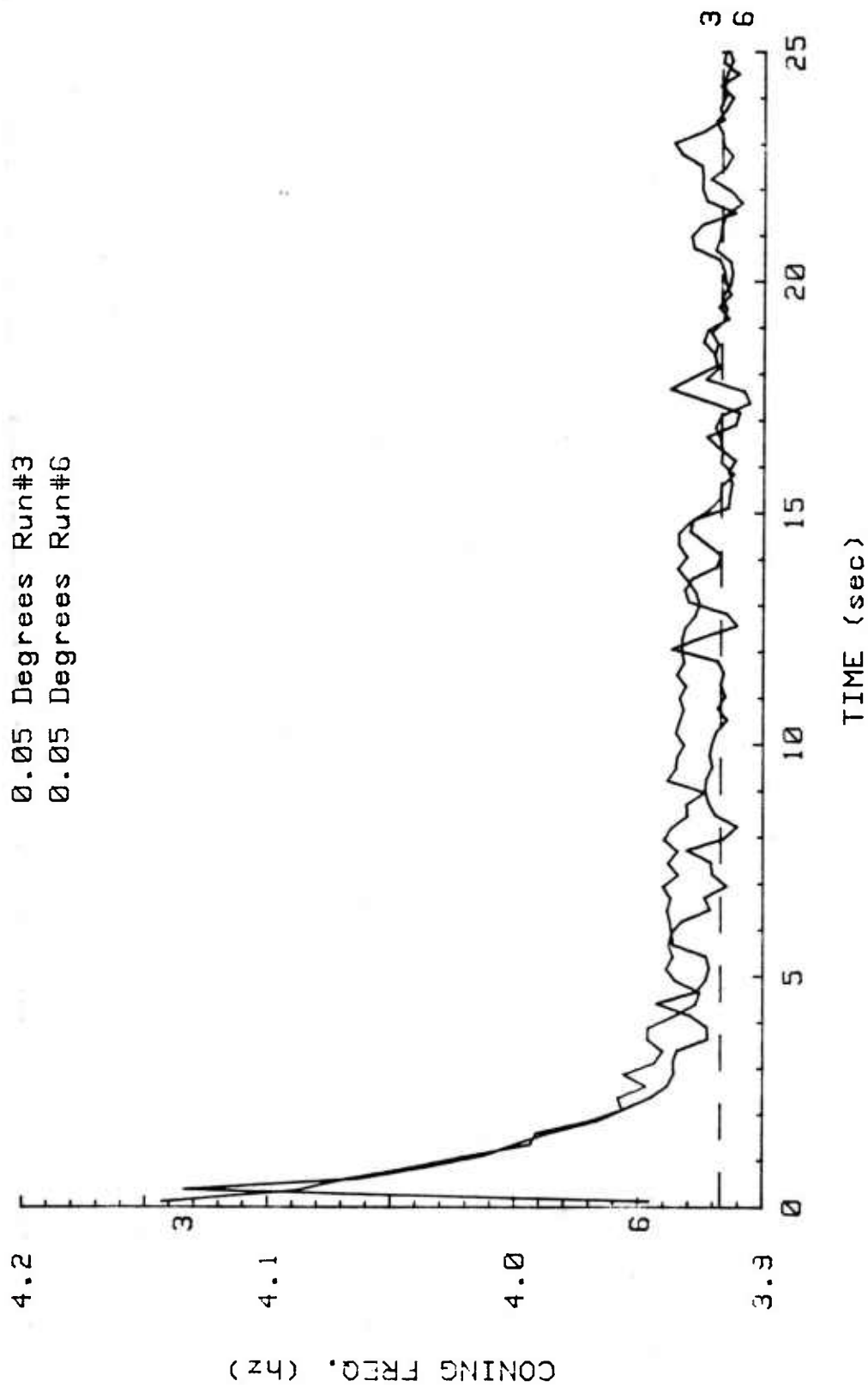

Figure A8. Coning Frequency History: 0.05 Degrees Runs #3 and #6

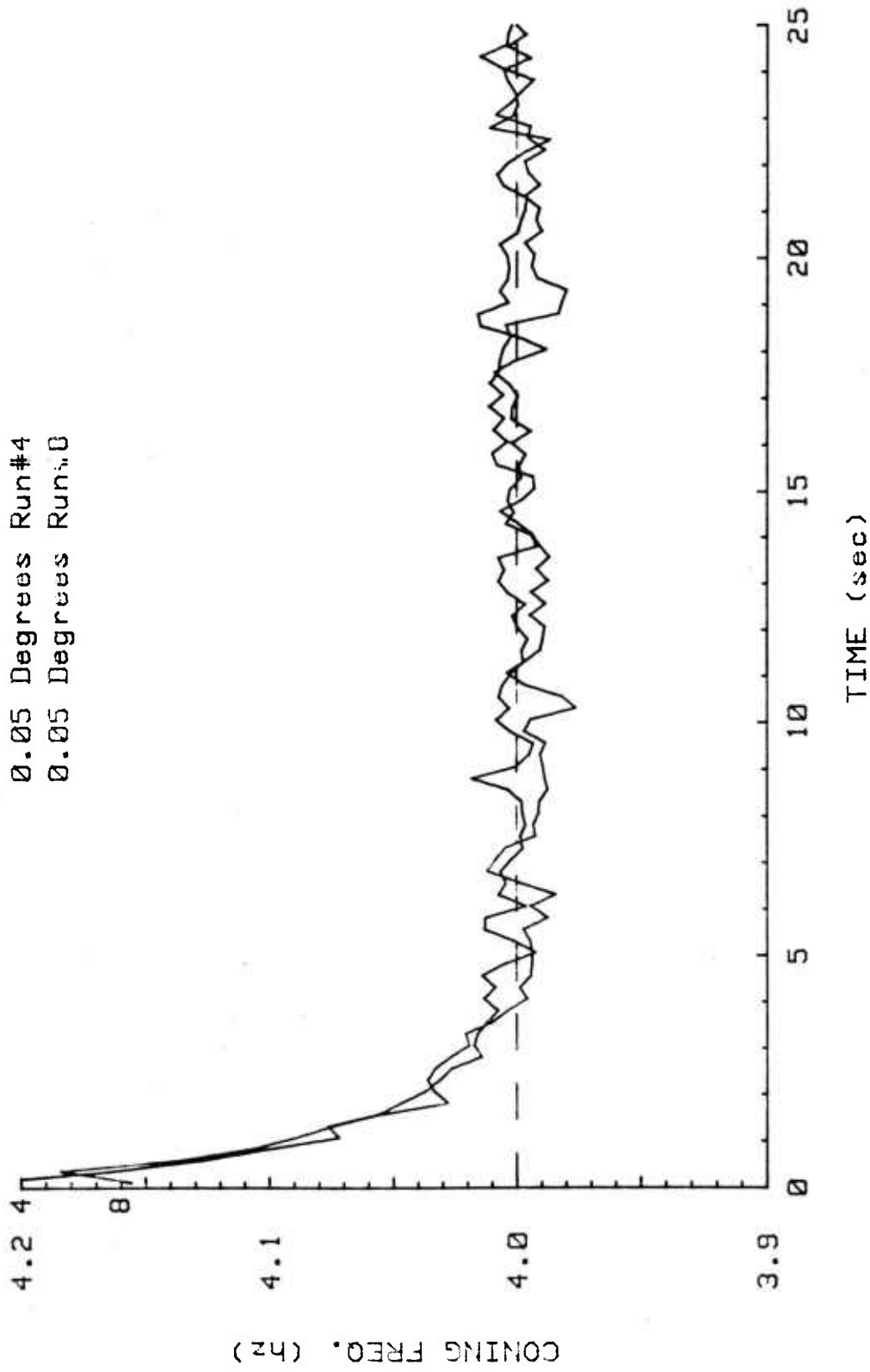

Figure A9. Coning Frequency History: 0.05 Degrees Runs #4 and #8

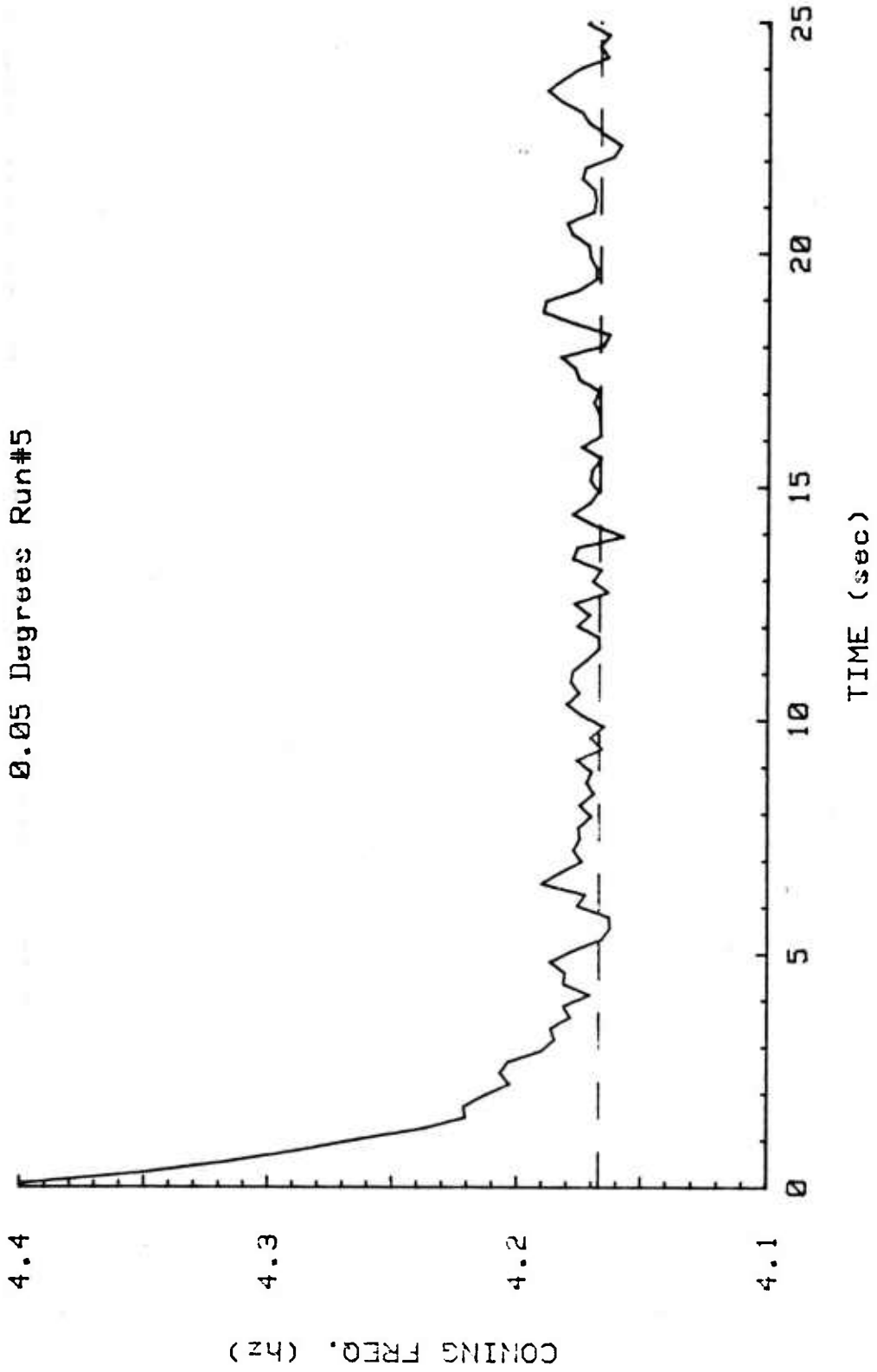

Figure A10. Coning Frequency History: 0.05 Degrees Run #5

DISTRIBUTION LIST

| <u>No. of Copies</u> | <u>Organization</u> | <u>No. of Copies</u> | <u>Organization</u> |
|--------------------------|---|--------------------------|---|
| 12 | Administrator Defense Technical Info Center ATTN: DTIC-DDA Cameron Station Alexandria, VA 22314 | 1 | Director US Army Armament Research and Development Command Benet Weapons Laboratory ATTN: DRDAR-LCB-TL Watervliet, NY 12189 |
| 1 | Commander US Army Engineer Waterways Experiment Station ATTN: R.H. Malter Vicksburg, MS 39181 | 1 | Commander US Army Aviation Research and Development Command ATTN: DRDAV-E 4300 Goodfellow Blvd St. Louis, MO 63120 |
| 1 | Commander US Army Materiel Development and Readiness Command ATTN: DRCDMD-ST 5001 Eisenhower Avenue Alexandria, VA 22333 | 1 | Director US Army Air Mobility Research and Development Laboratory ATTN: SAVDL-D, W.J. McCroskey Ames Research Center Moffett Field, CA 94035 |
| 1 | Commander US Army Armament Research and Development Command ATTN: DRDAR-TDC Dover, NJ 07801 | 1 | Commander US Army Communications Research and Development Command ATTN: DRDCO-PPA-SA Fort Monmouth, NJ 07703 |
| 3 | Commander US Army Armament Research and Development Command ATTN: DRDAR-TSS (2 cys) DRDAR-LC, Dr. J. Frasier Dover, NJ 07801 | 1 | Commander US Army Electronics Research and Development Command Technical Support Activity ATTN: DELSD-L Fort Monmouth, NJ 07703 |
| 4 | Commander US Army Armament Research and Development Command ATTN: DRDAR-LCA-F Mr. D. Mertz Mr. A. Loeb Mr. R. Kline Mr. S. Kahn Dover, NJ 07801 | 1 | Commander US Army Missile Command ATTN: DRSMI-R Redstone Arsenal, AL 35898 |
| 1 | Commander US Army Armament Materiel Readiness Command ATTN: DRSAR-LEP-L, Tech Lib Rock Island, IL 61299 | 1 | Commander US Army Missile Command ATTN: DRSMI-YDL Redstone Arsenal, AL 35898 |

DISTRIBUTION LIST

| <u>No. of Copies</u> | <u>Organization</u> | <u>No. of Copies</u> | <u>Organization</u> |
|--------------------------|---|--------------------------|--|
| 1 | Commander US Army Missile Command ATTN: DRSMI-RDK Mr. R. Deep Redstone Arsenal, AL 35898 | 4 | Commander Naval Surface Weapons Center Applied Aerodynamics Division ATTN: K.R. Enkenhus M. Ciment A.E. Winklemann W.C. Ragsdale Silver Spring, MD 20910 |
| 1 | Commander US Army Tank Automotive Research and Development Command ATTN: DRDTA-UL Warren, MI 48090 | 3 | Director National Aeronautics and Space Administration Ames Research Center ATTN: D.R. Chapman J. Rakich P. Kutler Moffett Field, CA 94035 |
| 2 | Commander US Army Research Office ATTN: Dr. R.E. Singleton Dr. Jagdish Chandra P.O. Box 12211 Research Triangle Park NC 27709 | 4 | Director National Aeronautics and Space Administration Langley Research Center ATTN: E. Price J. South J.R. Sterrett Tech Library Langley Station Hampton, VA 23365 |
| 1 | AGARD-NATO ATTN: R.H. Korkegi APO New York 09777 | 1 | Director National Aeronautics and Space Administration Lewis Research Center ATTN: MS-60-3, Tech Lib 21000 Brookpark Road Cleveland, OH 44135 |
| 1 | Director US Army TRADOC Systems Analysis Activity ATTN: ATAA-SL, Tech Lib White Sands Missile Range NM 88002 | 2 | Director National Aeronautics and Space Administration Marshall Space Flight Center ATTN: A.R. Felix, Chief S&E-AERO-AE Dr. W.W. Fowlis Huntsville, AL 35812 |
| 3 | Commander Naval Air Systems Command ATTN: AIR-604 Washington, DC 20360 | | |
| 2 | Commander David W. Taylor Naval Ship Research & Development Center ATTN: H.J. Lugt, Code 1802 S. de los Santos, Head, High Speed Aero Div. Bethesda, MD 20084 | | |
| 1 | Commander Naval Surface Weapons Center ATTN: DX-21, Lib Br Dahlgren, VA 22448 | | |

DISTRIBUTION LIST

| <u>No. of Copies</u> | <u>Organization</u> | <u>No. of Copies</u> | <u>Organization</u> |
|--------------------------|---|--------------------------|--|
| 2 | Director Jet Propulsion Laboratory ATTN: L.M. Mach Tech Library 4800 Oak Grove Drive Pasadena, CA 91103 | 1 | Vought Systems Division LTV Aerospace Corporation ATTN: J.M. Cooksey, Chief Gas Dynamics Lab. 2-53700 P.O. Box 5907 Dallas, TX 75222 |
| 1 | Arnold Research Organization, Inc. ATTN: J.C. Adams Arnold AFB, TN 37389 | 1 | Arizona State University Department of Mechanical and Energy Systems Engineering ATTN: G.P. Neitzel Tempe, AZ 85281 |
| 1 | Aerospace Corporation Aero-Engineering Subdivision ATTN: Walter F. Reddall El Segundo, CA 90245 | 3 | California Institute of Technology ATTN: Tech Library H.B. Keller, Mathematics Dept. D. Coles, Aeronautics Dept. Pasadena, CA 91109 |
| 1 | AVCO Systems Division ATTN: B. Reeves 201 Lowell Street Wilmington, MA 01887 | 1 | Cornell University Graduate School of Aero Engr ATTN: Library Ithaca, NY 14850 |
| 3 | Calspan Corporation ATTN: A. Ritter G. Homicz W. Rae P.O. Box 400 Buffalo, NY 14225 | 1 | Illinois Institute of Technology ATTN: H. M. Nagib 3300 South Federal Chicago, IL 60616 |
| 1 | Lockheed Missiles and Space Company ATTN: Tech Info Center 3251 Hanover Street Palo Alto, CA 94304 | 1 | The Johns Hopkins University Department of Mechanics and Materials Science ATTN: S. Corrsin Baltimore, MD 21218 |
| 2 | McDonnell-Douglas Corporation Douglas Aircraft Company ATTN: T. Cebeci K. Stewartson 3855 Lakewood Blvd Long Beach, CA 90801 | 1 | The Johns Hopkins University Applied Physics Laboratory ATTN: Dr. R.D. Whiting Johns Hopkins Road Laurel, MD 20707 |
| 3 | Sandia Laboratories ATTN: F.G. Blottner W.L. Oberkampf Tech Library Albuquerque, NM 87115 | | |

DISTRIBUTION LIST

| <u>No. of Copies</u> | <u>Organization</u> | <u>No. of Copies</u> | <u>Organization</u> |
|--------------------------|---|--------------------------|---|
| 3 | Massachusetts Institute of Technology ATTN: E. Covert H. Greenspan Tech Library 77 Massachusetts Avenue Cambridge, MA 02139 | 1 | Rensselaer Polytechnic Institute Department of Math Sciences ATTN: R.C. DiPrima Troy, NY 12181 |
| 2 | North Carolina State University Mechanical and Aerospace Engineering Department ATTN: F.F. DeJarnette J.C. Williams Raleigh, NC 27607 | 1 | San Diego State University Department of Aerospace Engineering and Engineering Mechanics College of Engineering ATTN: K.C. Wang San Diego, CA 92182 |
| 1 | Notre Dame University Department of Aero Engineering ATTN: T.J. Mueller South Bend, IN 46556 | 1 | University of California- Davis ATTN: H.A. Dwyer Davis, CA 95616 |
| 2 | Ohio State University Department of Aeronautical and Astronautical Engineering ATTN: S.L. Petrie O.R. Burggraf Columbus, OH 43210 | 1 | University of Colorado Department of Astro-Geophysics ATTN: E.R. Benton Boulder, CO 80304 |
| 2 | Polytechnic Institute of New York ATTN: G. Moretti S.G. Rubin Route 110 Farmingdale, NY 11735 | 1 | University of Hawaii Department of Ocean Engineering ATTN: G. Venezian Honolulu, HI 96822 |
| 3 | Princeton University James Forrestal Research Center Gas Dynamics Laboratory ATTN: S.M. Bogdonoff S.I. Cheng Tech Library Princeton, NJ 08540 | 2 | University of Maryland ATTN: W. Melnik J.D. Anderson College Park, MD 20742 |
| 1 | Purdue University Thermal Science and Prop Center ATTN: Tech Library W. Lafayette, IN 47907 | 1 | University of Santa Clara Department of Physics ATTN: R. Greeley Santa Clara, CA 95053 |
| | | 3 | University of Southern California Department of Aerospace Engineering ATTN: T. Maxworthy P. Weidman L.G. Redekopp Los Angeles, CA 90007 |

DISTRIBUTION LIST

| <u>No. of Copies</u> | <u>Organization</u> |
|--------------------------|--|
| 1 | University of Virginia Department of Aerospace Engineering and Engineering Physics ATTN: I.D. Jacobson Charlottesville, VA 22904 |
| 1 | University of Washington Department of Mechanical Engineering ATTN: Tech Library Seattle, WA 98105 |
| 1 | University of Wyoming ATTN: D.L. Boyer University Station Laramie, WY 82071 |
| 2 | Virginia Polytechnic Institute and State University Department of Aerospace Engineering ATTN: Tech Library W. Saric Blacksburg, VA 24061 |

Aberdeen Proving Ground

Director, USAMSAA
ATTN: DRXSY-D
DRXSY-MP, H. Cohen

Commander, USATECOM
ATTN: DRSTE-TO-F

Director, USACSL
Bldg. E3516, EA
ATTN: DRDAR-CLB-PA
M. Miller

Director, USACSL, EA
Bldg. E3330
ATTN: W.C. Dee
J. McKivrigan
C. Hughes

USER EVALUATION OF REPORT

Please take a few minutes to answer the questions below; tear out this sheet, fold as indicated, staple or tape closed, and place in the mail. Your comments will provide us with information for improving future reports.

1. BRL Report Number _____

2. Does this report satisfy a need? (Comment on purpose, related project, or other area of interest for which report will be used.)

3. How, specifically, is the report being used? (Information source, design data or procedure, management procedure, source of ideas, etc.) _____

4. Has the information in this report led to any quantitative savings as far as man-hours/contract dollars saved, operating costs avoided, efficiencies achieved, etc.? If so, please elaborate.

5. General Comments (Indicate what you think should be changed to make this report and future reports of this type more responsive to your needs, more usable, improve readability, etc.) _____

6. If you would like to be contacted by the personnel who prepared this report to raise specific questions or discuss the topic, please fill in the following information.

Name: _____

Telephone Number: _____

Organization Address: _____
