

AD-R122 136

INFLUENCE OF CHUCK DESIGN ON SPIN-OUT TORQUE IN
SOFTWOOD VENEER PEELING BLOCKS(U) FOREST PRODUCTS LAB
MADISON WI F J FRONCZAK ET AL. SEP 82 FSRP-FPL-427

1/1

UNCLASSIFIED

F/G 13/9

NL

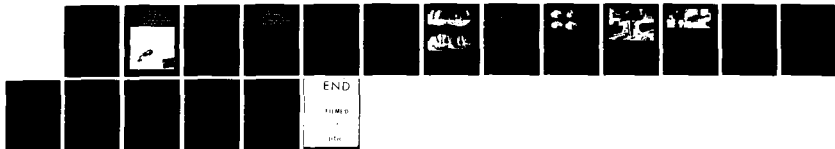

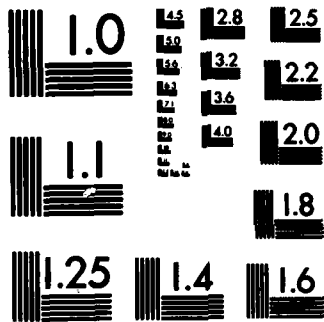

MICROCOPY RESOLUTION TEST CHART
NATIONAL BUREAU OF STANDARDS-1963-A

United States
Department of
Agriculture

Forest Service

Forest
Products
Laboratory

Research
Paper
FPL 427

Influence of Chuck Design on Spin-Out Torque in Softwood Veneer Peeling Blocks



AD A 122 136

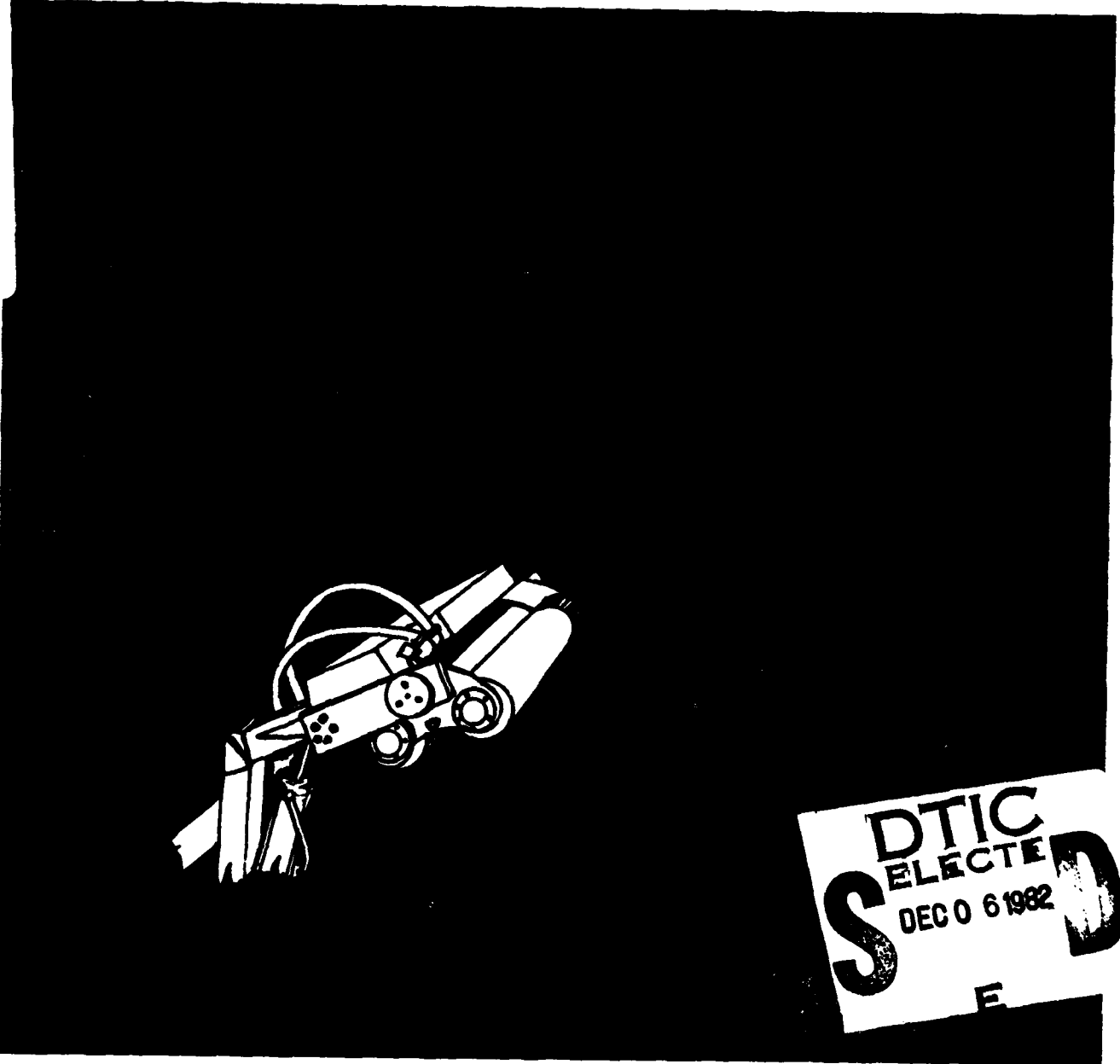

FILE COPY

This document has been approved
for public release and sale; its
distribution is unlimited.

82 12 06 060

Abstract

Five chuck configurations were used to determine maximum torque deliverable to peeling blocks of four species. Chucks with relatively slender spurs transmitted greater torque before spinning out than did chucks with relatively large circumferential surface profiles. Maximum torque increased with depth of spur penetration. Limiting factors were spur stiffness and strength.

Properly designed chucks can deliver substantially increased torque, thus reducing spin-out rate at a minimal cost.

Note

This paper is the first in a series of four papers describing the FPL powered back-up roll. The other Research Papers are:

- FPL 428 Powered Back-Up Roll—New Technology for Peeling Veneer**
- FPL 429 Laboratory Performance of a Powered Back-Up Roll for Peeling Veneer**
- FPL 430 Industrial Performance of Powered Back-Up Roll for Peeling Veneer**

United States
Department of
Agriculture

Forest Service

Forest
Products
Laboratory¹

Research
Paper
FPL 427

September 1982

Influence of Chuck Design on Spin-Out Torque in Softwood Veneer Peeling Blocks



By
FRANK J. FRONCZAK, Research General Engineer
and
ROBERT A. PATZER, Physical Science Technician

Unannounced Justification	
<input checked="" type="checkbox"/> <input type="checkbox"/>	
By _____ Distribution/	
Availability Codes	
Dist	Avail and/or Special
A	

Introduction

Increasing log costs have increased the need to achieve maximum recovery from logs. Because veneer is one of the most valuable products recovered from a log, developments that increase veneer yield are especially important to effecting better utilization of our natural resources.

As the supply of large-diameter peeler logs has diminished, the problem of reduced yield has been accentuated. The relatively small size of logs being peeled and the necessity of peeling to smaller core diameters aggravate problems that exist even with large-diameter logs. One problem that is especially influenced by efforts to reduce core diameter is spin-out.

Spin-out occurs when the torque required to turn the veneer bolt exceeds the amount deliverable to the bolt through the chucks, and the chucks spin free in the ends of the bolt. While no detailed information is available that accurately defines the magnitude of the problem, it is certainly significant. Different plants suffer the problem in varying degrees, but the result is the same in all. Veneer bolt spin-outs waste both money and raw material that could be converted into useful products.

In 1974, at the request of the Forest Products Laboratory (FPL), the American Plywood Association surveyed 47 plywood plants for causes of unpeelable

logs. The most common problems were soft centers, spin-out, and splits in logs. The percent unpeelable varied from negligible to 40 percent. The "negligible" reports came from mills that had already segregated the logs before they arrived at the mill. Based on this survey, a reasonable estimate would be that 25 percent of logs from the forest are considered not peelable. Among logs considered peelable, a certain percentage still spin-out. Estimates from industry indicate that as many as 7 percent of sound new-growth logs spin-out.

To put this into perspective, consider a plywood plant producing 100 million square feet per year, 3/8-inch basis, from logs averaging 14 inches in diameter. With logs this size, spin-out generally occurs when the outer chucks retract. This results in an oversized core of about 8 or 9 inches in diameter, compared to the typical target core diameter of 5 inches. With a spin-out rate of 7 percent, the loss is equivalent to almost 7 million square feet of 1/8-inch veneer. At a cost of \$38 per thousand square feet, such a loss would amount to more than \$160,000 per year for that plant. While better peeling techniques and better chuck designs will not completely eliminate oversized cores, it is apparent that reducing the spin-out rate by even 1 percentage point would be significant.

Background

The problem of veneer bolt spin-out has been investigated using a number of different approaches. The fundamental problem is to provide sufficient torque to the bolt through the chucks to overcome the forces encountered when peeling the bolt. The torque, T , re-

¹ Maintained at Madison, Wis., in cooperation with the University of Wisconsin.

quired to peel veneer is a function of the tangential component of the cutting force, F_T , the radius, R , the angular acceleration of the bolt, α , and the mass moment of inertia, I .

$$T = F_T R + I \alpha.$$

For the case most common in practice, in which spin-out occurs when the outer chuck retracts, the component of torque due to the angular acceleration of the block is negligible compared to the torque due to the cutting force. So, for all practical purposes, the torque delivered to the bolt during peeling is $T = F_T R$ (fig. 1).

Previous experiments have investigated the effects that various treatments have on both the magnitude of F_T and the ability of the chucks to impart a greater torque to the bolt (9).²

The resultant cutting force has several components. Among these are frictional drag between the knife and the bolt, friction between the pressure bar or roller and the bolt, the tangential force between the knife and the bolt required to cut the wood fibers, and the radial force that the pressure bar exerts on the bolt. All of these forces directly or indirectly affect the tangential component of the cutting force and thus the torque required to peel veneer.

Both analytical and experimental studies have been conducted to determine the magnitudes of the component and resultant forces. Among the factors affecting the magnitude of the forces are veneer thicknesses, wood temperature, type of pressure bar, and lathe settings (5,9-11).

Factors Affecting Cutting Force

Veneer Thickness The resultant cutting force generally increases with an increase in the thickness of veneer being cut. Kollmann found that the power required to cut veneer was roughly proportional to the thickness of the veneer (5). It is not clear, however, if this is a consequence of the different thicknesses directly or of the different pressure bar settings normally used for different thicknesses of veneer. While it is likely that the force required to actually cut the wood does not change with a change in veneer thickness, this force is only one component of several encountered in peeling veneer. Thicker veneers are usually peeled with more absolute pressure bar compression than are thin veneers even though the percent compression may be less. This certainly increases the drag between the pressure bar and the bolt. It also can increase the friction between the knife and the veneer. Both of these increases would cause an increase in the resultant cutting force when peeling thicker veneer. In any event, the thickness of the veneer being cut is normally determined by the total thickness and construction of the panel rather than by its effect on cutting force and thus

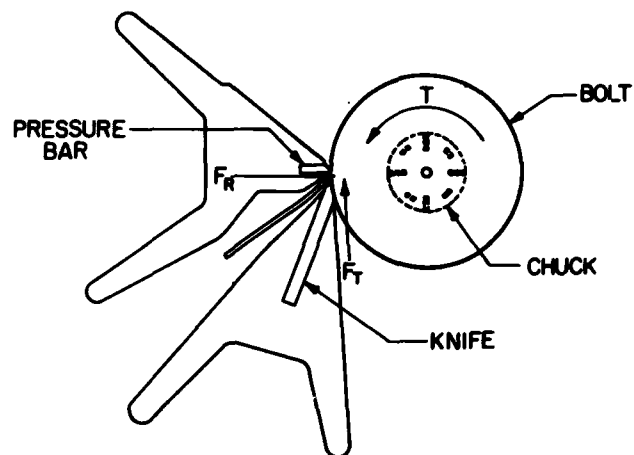

Figure 1.—Cross section of a veneer lathe showing resultant cutting forces and torque.

(M 149 924)

spin-out. Thus, while reducing the thickness of the veneer being cut could result in less bolt spin-out, other considerations dictate the thickness of the veneer being peeled.

Log Heating Procedures employed in log heating are a somewhat controversial subject. Lutz (7) indicated that for southern pine, for the same lathe settings, heated wood exerts less force on the pressure bar. This should result in reduced friction at the pressure bar, with a corresponding decrease in the torque required to peel veneer. Studies with basswood also showed a direct correlation between wood temperature and the torque required to cut veneer (9). While it is apparent that the torque required is reduced somewhat by log heating, the strength of the wood—and thus its ability to transmit torque—is diminished at higher temperatures. For basswood the torque required to cut veneer at 145°F is approximately 75 percent of the torque at 90°F. Similarly, the strength properties of wood at 150°F are about 75 percent of the values at 90°F (13). In spite of the reduced strength of the wood, it appears that proper log conditioning reduces the spin-out rate. In one case (3), a decrease in the spin-out rate, from 7 percent to 3 percent, was attributed to increasing the log heating time.

Regardless of the effect that log heating has on spin-out rate, its beneficial effects on the quality of the veneer are well documented (2,6-8). Veneer cut from properly heated logs is generally tighter and smoother than veneer cut from unheated logs. Because the knots are softened when heated, knife damage and subsequent downtime are reduced. Because of these beneficial effects, log heating will continue in the foreseeable future.

To achieve the benefits attainable from heating logs, it is important that the heating is done properly. Because

² Italicized numbers in parentheses refer to literature cited at end of report.

of the nature of wood, its thermal conductivity is approximately 2 to 3 times greater parallel to the grain than in either the radial or tangential directions (12). Thus the ends of the logs heat much more rapidly than the center. If the heating medium is hotter than the desired cutting temperature, the ends of the log will reach the temperature of the heating medium long before the wood near the core is heated to the optimum temperature for peeling. Similarly, if the log is heated by a medium close to the final desired temperature, but for an insufficient length of time, the outer wood and the ends will be sufficiently heated, but the interior of the log will not be at the temperature desired for good peeling. In both of these cases, the spin-out problem will be aggravated. That is, the strength of the wood at the ends of the log will be reduced, thus reducing the maximum torque deliverable to the bolt through the chucks. This is tolerable only if the wood near the center of the log being peeled has also been heated sufficiently. But in the cases described here, the interior wood is not sufficiently heated, resulting in a higher cutting force, thus increasing the torque required to turn the bolt. This increase in cutting torque, combined with a decrease in the strength of the wood and its ability to transmit torque, cannot fail to increase the probability of bolt spin-out.

For optimum log heating, it is important to sort the logs according to size and then heat them to a nearly uniform temperature best determined by veneer quality criteria.

Pressure Bar An important factor that affects the tangential component of the cutting force, and thus the required torque, is the type of pressure bar used. Two types in general use are the fixed bar, primarily for peeling hardwoods, and the roller bar for peeling softwoods. Research indicates that cutting forces are lower when a roller bar is used (1,9). The type of pressure bar selected is generally dictated by considerations other than its effect on bolt spin-out. The use of a roller nosebar results in lower forces than the use of a conventional fixed pressure bar. One of the significant disadvantages of the roller bar is its inherent complexity, resulting both in higher initial and maintenance costs. Recent research conducted at the Western Forest Products Laboratory³ may provide a nosebar with the desirable characteristics of the roller bar but without the high maintenance costs (14). This bar is a fixed, contoured, steam-heated nosebar. Preliminary work indicates that the steam-heated nosebar reduces friction as compared to conventional fixed bars and produces higher quality veneer than roller nosebars. In addition, maintenance is dramatically reduced with an accompanying reduction in production downtime.

Any development that affects the frictional force exerted on the nosebar will have a direct bearing on the amount of torque required to turn the bolt. This, in turn,

affects the spin-out rate. While information is not available on the effect of the contoured steam-heated nosebar specifically on spin-out, it should—because of its reduced friction—contribute to a reduced spin-out rate.

Lathe Settings Research results and in-plant experience indicate that lathe settings can have a significant effect on cutting forces and thus spin-out rates. Work done at FPL shows that different knife angle and pressure bar gap settings can affect the required torque by as much as 40 percent (9). Changes of this magnitude will obviously have an effect on the spin-out rate. In a mill study done by the Western Forest Products Laboratory, changing the lathe settings to recommended values decreased the spin-out rate from greater than 10 percent to about 6 percent (4). Adjusting the lathe to the proper settings also resulted in an improvement in the quality of the veneer.

Factors Affecting Deliverable Torque

In addition to the factors that affect the required cutting torque, the amount of torque deliverable to the log will also affect the spin-out rate. Spin-out will occur when the required cutting torque exceeds the capability of the wood in the vicinity of the chucks to withstand the load applied through the chucks. If the required cutting torque is below this threshold value, normal peeling will occur. However, when the strength of the wood is inadequate to transmit the required torque from the chucks to the block, spin-out occurs, the wood in the vicinity of the chuck fails dramatically, and peeling cannot continue.

Spin-Out Mechanism Inspection of spun-out blocks (fig. 2) reveals that the wood fails along the circumference of the chuck to a depth somewhat deeper than the length of the spurs. During peeling, the torque is transmitted to the log by rolling shear from the wood within the circumference of the chuck to the wood outside this area (fig. 3). The area over which this rolling shear acts is essentially a cylinder with a diameter equal to the diameter of the chuck and a depth somewhat greater than the length of the spurs. Some of the torque load is also transmitted by transverse shear across the circular surface at the tips of the spurs; however, examination of spun-out blocks clearly reveals that the wood fails in rolling shear when failure (spin-out) occurs. Factors that increase the rolling shear area—that is, the cylindrical area over which the rolling shear acts—will result in a decrease in the rolling shear stress for a given torque value. This would allow greater torque to be transmitted before spin-out is initiated by the rolling shear failure of the wood. This accounts for the effectiveness of both larger chuck diameters and longer spurs in reducing the likelihood of spin-out.

Nested Chucks The logical and effective first approach to this aspect of the problem is to use larger-diameter chucks, as the deliverable torque increases with the chuck diameter. This is the basis for retractable chucks. When

³ Forintek Canada Corp., Western For. Prod. Lab., Vancouver, B.C.

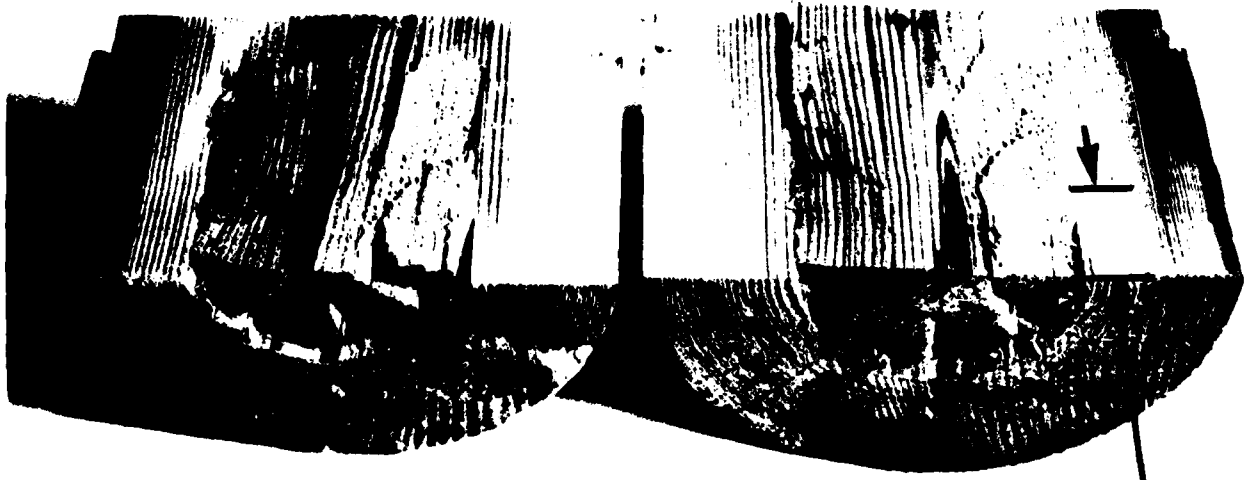

Spur
Penetration
Depth

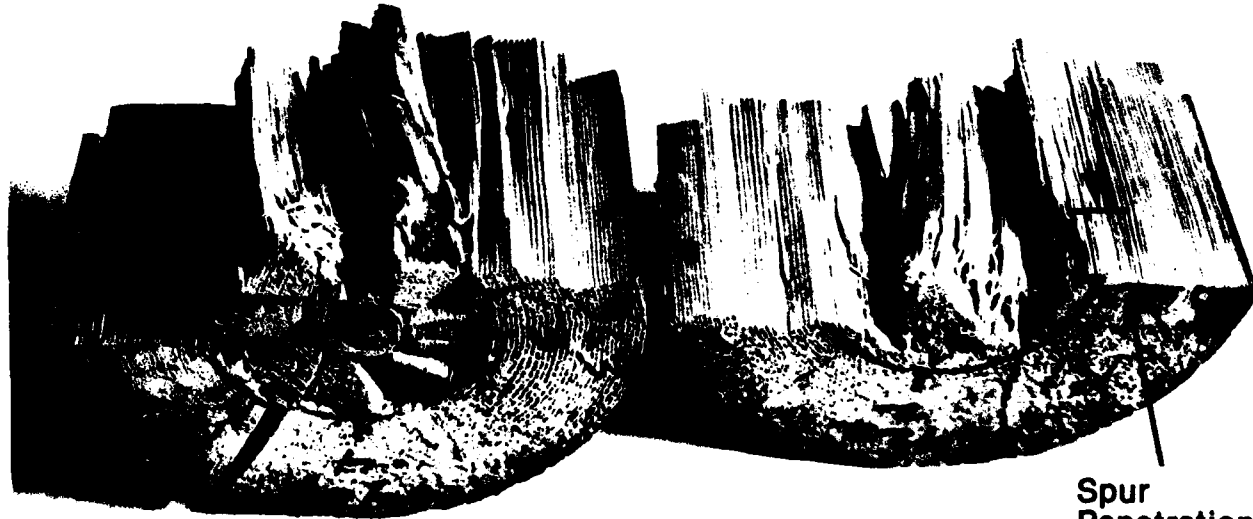

Spur
Penetration
Depth

Figure 2.—Blocks showing spin-out.

(M 147 258) (M 147 259)

the required torque is highest, because of a relatively large bolt radius, the deliverable torque is also highest. As the bolt is peeled and the radius decreases, the required torque decreases as well. When the outer chuck is retracted, the required torque has been reduced from its initial value; but the deliverable torque of the inner, smaller-diameter chuck is also smaller. When the required torque exceeds the deliverable torque at this critical point, spin-out will occur. To maximize the veneer yield from the bolts, it is desirable to use as small a chuck as possible for the inner chuck. This aggravates the spin-out problem. While the use of dual spindles is a definite improvement over single spindles,

it obviously does not provide a completely satisfactory solution to the spin-out problem. Evidence of this is the continued occurrence of spin-out and the multitude of different chucks designed in an attempt to cope with the problem. Because of a lack of basic information, chuck design has been based largely on intuition.

To overcome these deficiencies, FPL, in cooperation with industry, began a program to evaluate a representative sample of existing chuck designs. The original study by Lutz and Patzer (9) evaluating 16 different chuck designs was intended as a general survey of the field and did not involve a detailed evaluation of the

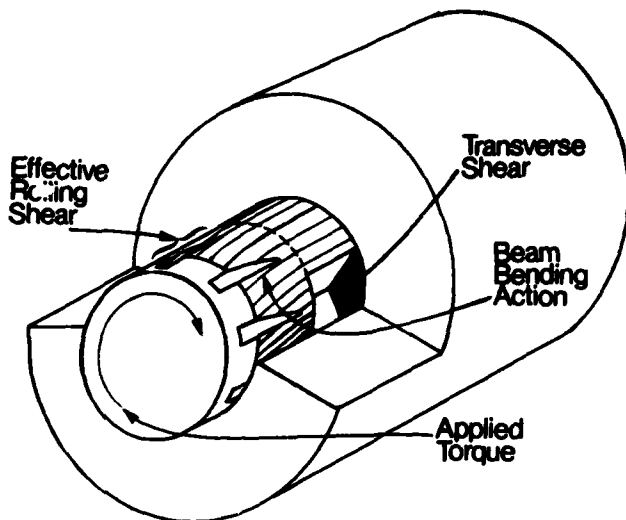

Figure 3.—Modes of load transfer from chuck to log.

(M 149 925)

performance of the chucks in different species of wood.

Using the results from that initial study, two chucks were selected for further testing. These two, plus one designed at FPL and a commercial chuck, were tested with Douglas-fir, southern pine, white fir, and western hemlock. A fifth chuck, an experimental configuration tested by a major wood products company, was tried with Douglas-fir and southern pine using a slightly different procedure. This study was intended to provide sufficient information to develop a rational approach to chuck design.

Experimental Procedure

Stage I

The four chucks examined in Stage I of this study (fig. 4) were all 4 inches in diameter with 1-1/2-inch-long spurs. All of the chucks except No. 2 had eight individual spurs; chuck 2 had four semicircular spurs.

Douglas-fir, southern pine, western hemlock, and white fir were tested during this part of the study. All logs were relatively sound, without any defects that would render them unpeelable. The Douglas-fir logs were received with the bark still on. The other species had been debarked prior to shipment to FPL, and had been protected from excessive drying by covering during shipping. All logs were sprinkled while stored.

Eighteen Douglas-fir bolts and 22 western hemlock bolts were peeled to a 9-1/2-inch diameter and one end of each specimen trimmed to fit the test fixture (fig. 5). Fifty-five white fir bolts and 39 southern pine were peeled to 8-1/2-inch and 8-inch diameters, respectively, before end trimming. Each 8-foot bolt was cut into four 2-foot-long test blocks. To provide as direct a comparison between chucks as possible, each chuck was

tested with one block from each bolt. Thus all four chucks were tested in the adjacent, freshly cut surfaces of the blocks.

The chucks were tested using a modified machine lathe (fig. 6). Sufficient end pressure to fully set the chucks in the test specimens was provided by the hydraulic cylinder fixed to the lathe tailstock. When the blocks were fully chucked, they were inspected to determine if splitting of the blocks was evident. When the chucks were fully set, the pressure in the cylinder was reduced so that a force of approximately 2,500 pounds was applied while the chuck was being turned. A thrust bearing was located between the hydraulic cylinder and the bolt so that the only reaction to the torque applied through the chuck was that provided by the lever arm acting against the load cell. The torque was measured using a load cell that was fixed to the lathe bed and provided the reaction to the yoke lever arm. The block was restrained by the lever arm reacting against the load cell. Thus the block was not free to rotate, and the chuck was forced to spin-out when the chuck was turned. The chuck was driven by the lathe at 7 revolutions per minute until the torque peaked and dropped off. The force measured by the load cell, and thus the torque, was recorded on a strip chart recorder. The maximum torque developed was measured from the strip chart recording.

The pressure in the hydraulic cylinder used to set the chucks was also measured continuously and recorded on the strip chart recorder.

The procedure used is obviously somewhat different than what actually occurs in practice. However, it provides a repeatable, precise procedure by which the maximum torque generated by different chucks can be compared.

Samples were taken from the end of each section to measure the specific gravity of the test specimens. These data were recorded along with the maximum torque values.

Stage II

After testing had been substantially completed with the first four chucks, a major wood products company approached FPL with an experimental chuck configuration that they felt would provide considerable torque to the bolt. This chuck (fig. 7) was tested using essentially the same method and equipment, except as noted otherwise, as were the original four chucks.

This chuck differs substantially from the others. It has a diameter of 3.75 inches and six spurs, each 3.5 inches long.

To facilitate block preparation, a different fixture was fabricated to hold the blocks and provide the resisting torque (fig. 7). Rather than trimming the ends of the blocks as was described previously, the round blocks were gripped between plates. The plates provided ade-

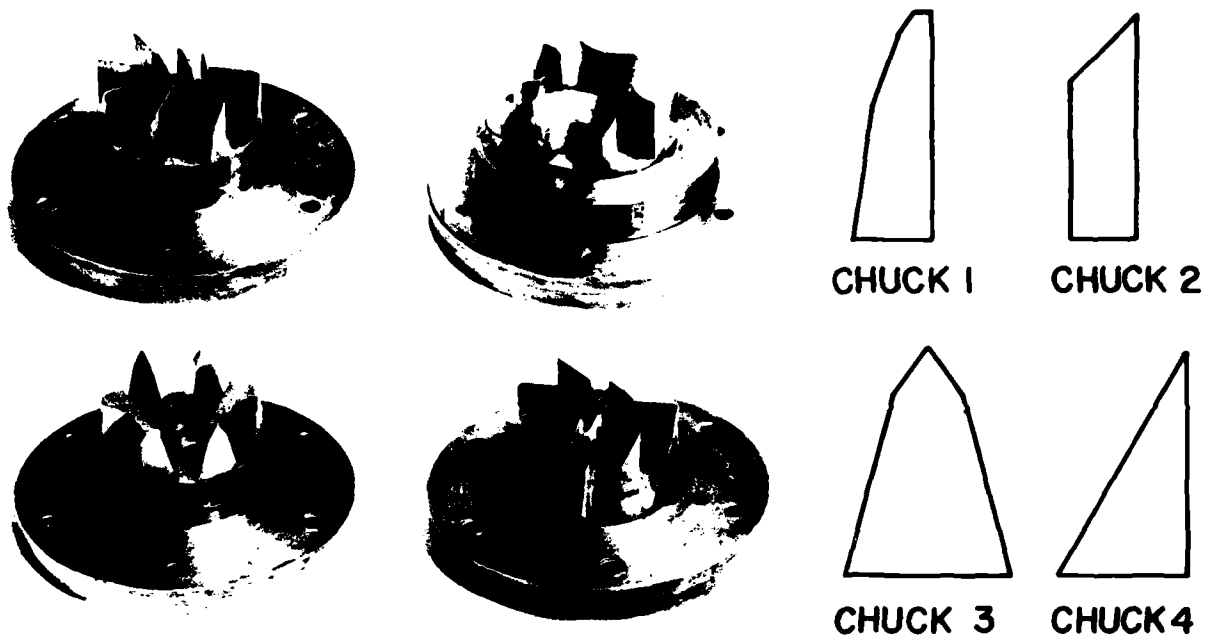

Figure 4.—Four chucks tested in Stage 1: Photos and spur cross sections.
(M 147 266) (M 147 265) (M147 263) (M149 926)

quate resistance to slipping and eliminated the time-consuming work of trimming the block ends.

The variables investigated in this part of the study included species, depth of penetration, and wood temperature. Southern pine and Douglas-fir were the two species tested. The chuck was tested at depths of 1, 1-1/2, 2-1/4, and 3-1/4 inches, and at temperatures of 60°, 120°, and 150° F. The blocks were 7-1/2 inches in diameter when tested. Because of the large number of variables involved, five blocks were tested at each variable value. The test specimens were obtained from oversize cores that had been previously peeled for veneer. These cores were then peeled to 7-1/2 inches in diameter and crosscut to length. The blocks were all kept under water in holding tanks prior to testing. Those tested at 120° and 150° F were heated for at least 12 hours before testing. The blocks were tested immediately upon retrieval from the hot water tanks to avoid the ends cooling off. The actual spin-out testing and data acquisition followed the same procedure as described for the other four chucks.

Results

Stage I

Examination of the blocks after spin-out showed that the wood damage extended somewhat deeper than the spur penetration. The blocks showed a consistent pattern of failure in which the wood outside the circumference of the chuck was left relatively undamaged while the wood inside the chuck circumference was severely damaged. Observation of the failed specimens indicated that the wood failed in rolling shear around the circumference of the chuck. It also appeared that

after spin-out had been initiated by the rolling shear failure, the wood remaining within the circumference of the chuck was loaded in bending. Tensile failures in the wood at the deepest point of wood damage indicated the presence of bending loads on the wood. This can perhaps be best understood by visualizing the wood between spurs as being short beams cantilevered from a point somewhat deeper than the actual depth of spur penetration. After spin-out is initiated and rolling shear failure has occurred, these cantilevered beams transmit some torque by carrying the load in bending and transverse shear.

An examination of the data indicated that chucks 1 and 2 consistently exhibited a higher average torque value than did chucks 3 and 4 (fig. 8). As is the case in any experiment yielding data with a wide range of values, an amount of uncertainty exists about the validity of the conclusions drawn from that data. In this case the data support the conclusions at a 95 percent or greater confidence level. To make a more definitive statement, it would be necessary to significantly increase the sample size.

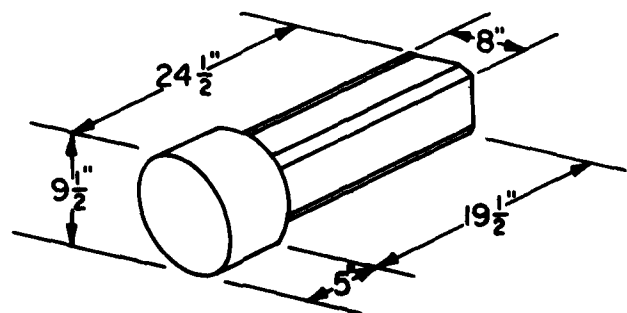

Figure 5.—Typical specimen.

(M 149 927)

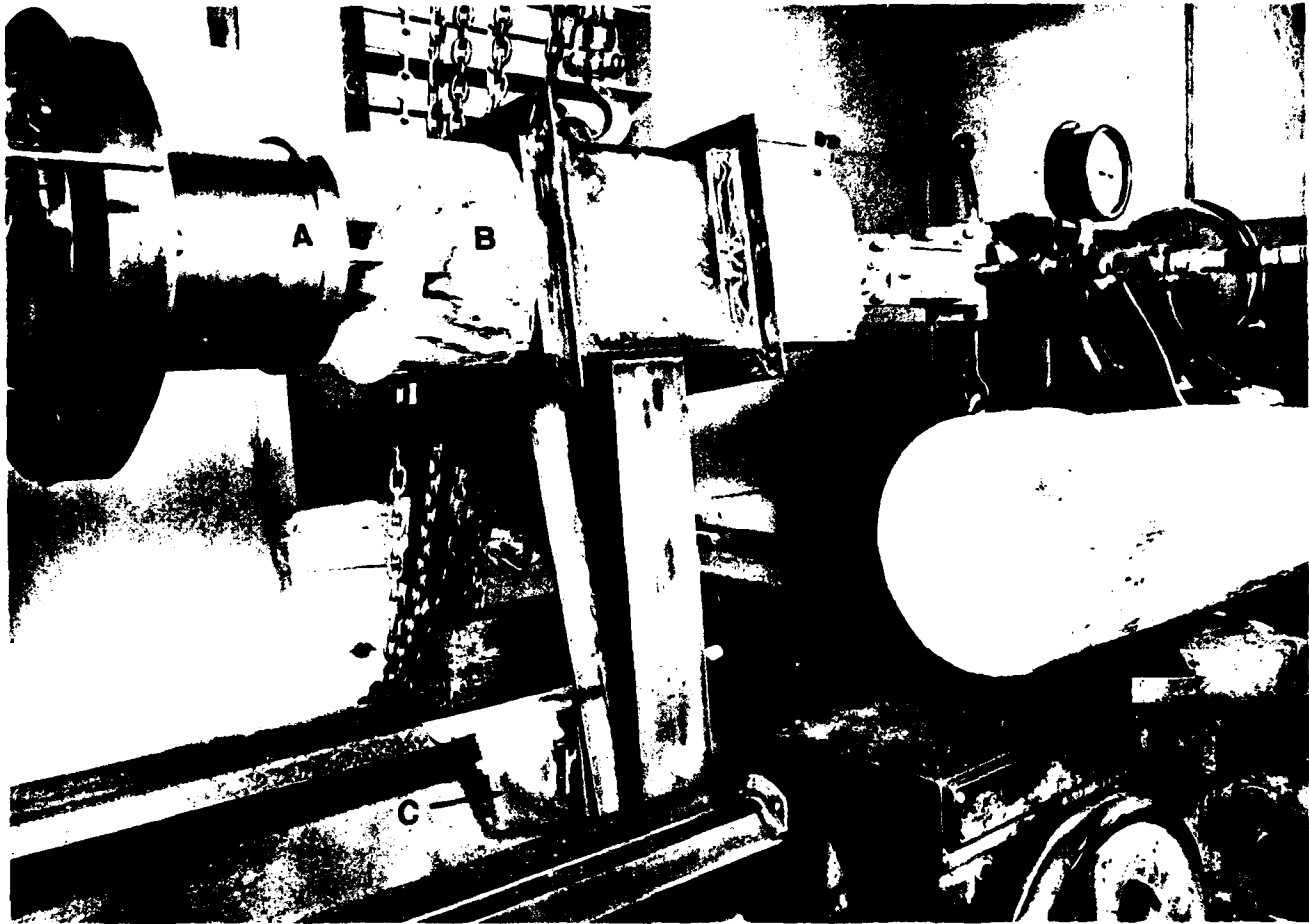

Figure 6.—Test setup, Stage I. A. Chuck B. Test specimen C. Load cell

(M 144 724-7)

Based on a statistical analysis of the data, the following conclusions were reached. In white fir, chucks 1 and 2 appeared to be indistinguishable, as did chucks 3 and 4. Chucks 1 and 2 attained, on the average, significantly higher torques than did chucks 3 and 4. The average difference between chucks 1 and 2 and chucks 3 and 4 was approximately 1,100 inch-pounds.

A somewhat similar pattern evolved when the data from all the species were investigated. In white fir and hemlock, chuck 1 developed somewhat higher torque than did chuck 2 and vice-versa for southern pine and Douglas-fir. These differences were relatively small and, considering the variability of the data, not significant at a 95 percent confidence level. A similar pattern occurred in comparing chuck 3 with chuck 4: chuck 3 developed somewhat higher average torque with white fir, hemlock, and southern pine. With Douglas-fir, chuck 4 delivered higher average torque.

Statistical analysis of the data indicates that chucks 1 and 2 deliver significantly greater torque than do chucks 3 and 4. The differences between 1 and 2 and between 3 and 4, however, are relatively insignificant.

Plots of data (figs. 9-12) clearly showed the wide range of torque values, even within each log. The number of times that each chuck provided the maximum torque in each block was tabulated (table 1). Where more than one chuck had the same torque value, each chuck was counted as providing maximum torque. Again, chucks 1 and 2 taken as a group delivered the maximum torque a significantly greater number of times than did chucks 3 and 4.

The relationship between torque, wood species, and chuck configuration was also examined. Clearly, there are substantial differences between wood species. Southern pine develops the highest torque values and white fir the lowest. The differences between the chucks are less apparent although chucks 1 and 2 transmit more torque than chucks 3 and 4. While there is not an exact correlation between torque and specific gravity, the trend is apparent. The maximum torque transmitted is proportional to specific gravity (fig. 13).

Stage II

The fifth chuck was tested using both 7-1/2-inch-diameter and 4-1/2-inch-diameter blocks, but the vast



Figure 7.—Chuck showing spur deflection and test setup, Stage II.

(M 146 740-3)
(M 146 740-4)

majority of the 4-1/2-inch-diameter blocks split drastically during chucking. Apparently, the method by which the torque was transmitted from the chuck to the block was significantly different than that which occurs in normal operation. Because of this and because of the highly erratic nature of the failures, the data obtained from the 4-1/2-inch-diameter blocks are con-

sidered irrelevant and not representative of what occurs in practice. Consequently, those data are not presented here.

The data obtained with the 7-1/2-inch blocks, however, appear reliable and relevant. The factors controlled in this part of the testing were block temperature and depth of spur penetration. Data were obtained for southern pine and Douglas-fir.

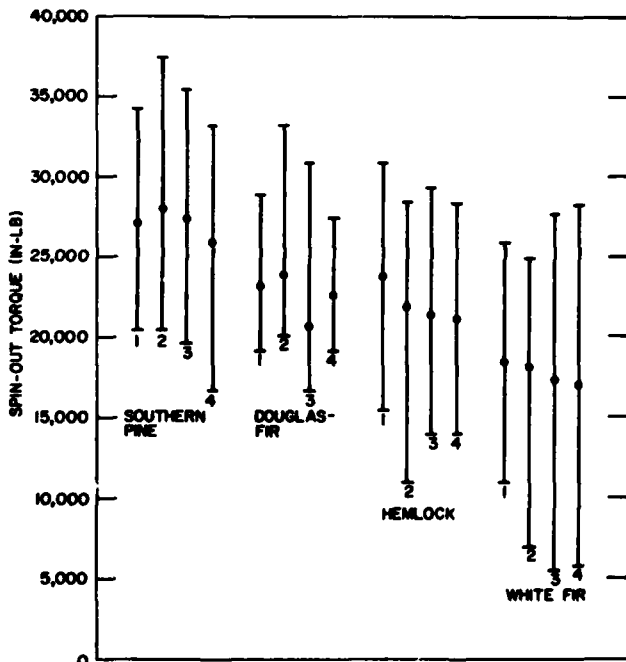

Figure 8.—Spin-out torque showing average value and ranges, for each chuck (Nos. 1, 2, 3, 4) for each block species (39 blocks per chuck for southern pine; 18 blocks per chuck for Douglas-fir; 22 blocks per chuck for western hemlock; 55 blocks per chuck for white fir). (M 149 928)

A direct comparison of the spin-out torque values of this experimental chuck with the four previous chucks is somewhat inappropriate because of the difference in diameter and spur length. It should be remembered that this chuck is an experimental one, and its dimensions are substantially different from those usually found in practice. Also, because of the introduction of additional variables—temperature and depth of penetration—during this phase of the testing, a smaller number of specimens (five) was tested at each parameter value. It is worthwhile to examine the results of the testing independently of the first four chucks, keeping in mind both the differences and the similarity in mode of failure between the first four chucks and the fifth chuck.

The results of this phase of the testing are much as expected. Examination of the data shows that generally, as temperatures increased, the average maximum torque decreased (fig. 14). This corroborates the work reported by Lutz and Patzer (9) and is readily explained by the fact that wood strength decreases with an increase in temperature. Also, not surprisingly, the average maximum torque increases with increased depth of penetration (fig. 15). As before, a fairly broad range exists in the data; however, a statistical analysis of the data indicates that both temperature and depth of penetration are significant at the 95 percent confidence level.

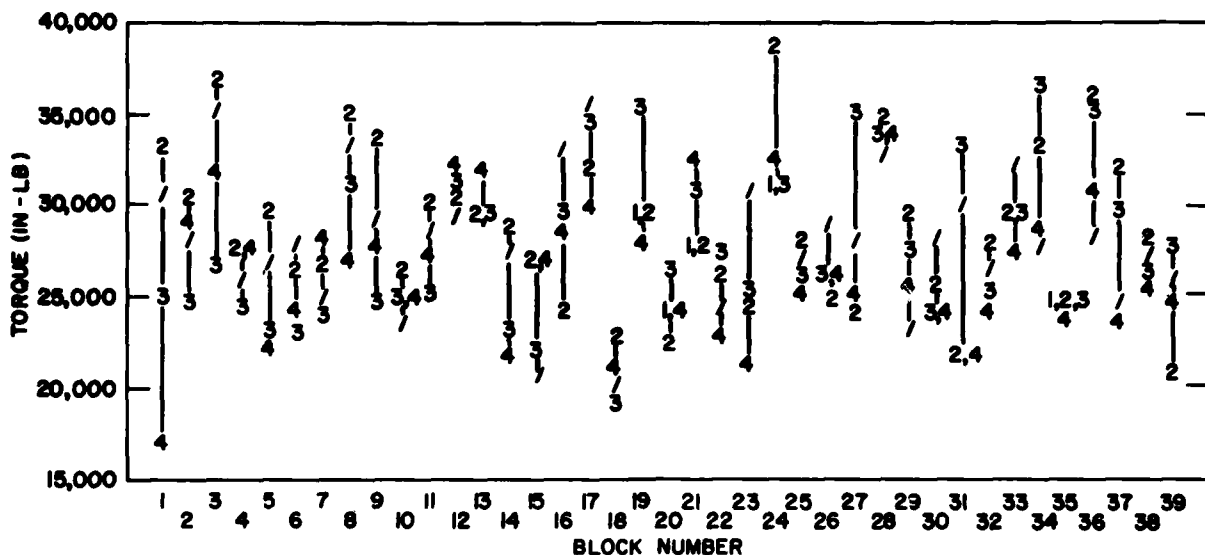

Figure 9.—Torque developed by each chuck on each block (southern pine).

(M 149 929)

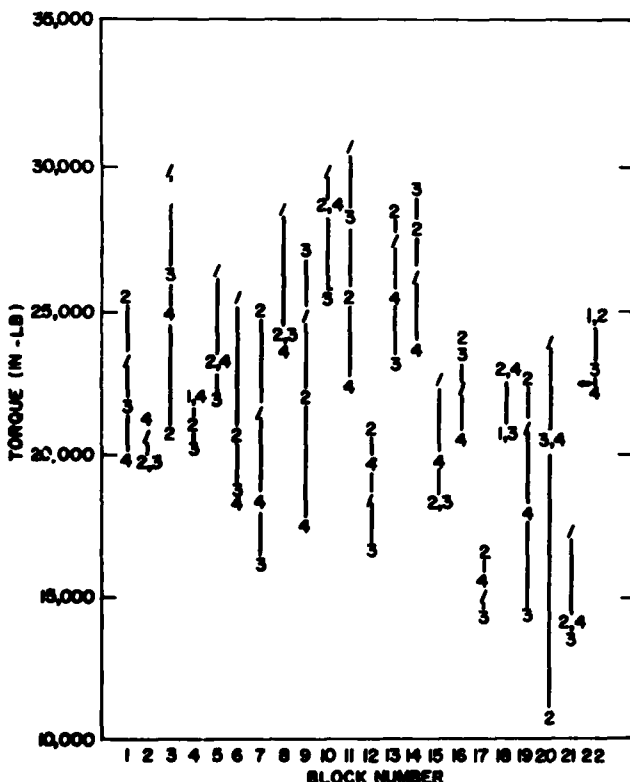

Figure 10.—Torque developed with each chuck on each block (hemlock).

(M 149 930)

One problem that became apparent before actual testing began was that, for chucks with long slender spurs, the hardness of spurs is a very important factor. The first chuck received had been heat treated to a hardness of approximately 56 on the Rockwell C scale. While this results in a relatively high yield point, the chuck spurs are too brittle at this hardness; one spur broke off before maximum torque was developed. The chuck actually used in the testing had a hardness of approximately 45 on the Rockwell C scale and did not break during the entire test program but the spurs developed a permanent deformation (fig. 7). This permanent set was first observed when testing the chuck with 120° F Douglas-fir blocks at 3-1/4-inch depth of spur penetration. The deformation is relatively slight, and while it does not appear to affect the deliverable torque directly it could lead to problems and is undesirable. With proper design the chuck could be modified slightly to eliminate any permanent deformation of the spurs.

Discussion

Based on previous work investigating the relationship between chuck design and deliverable torque, it was not obvious what type of results could be expected. While it was clear that the diameter of the chuck and the spur depth of penetration significantly affected the deliverable torque, the effect of spur configuration was not recognized. In fact, because of the existence of such a wide variety of designs available, it would appear that no one or two optimum spur configurations existed. If an optimum chuck existed, it would seem

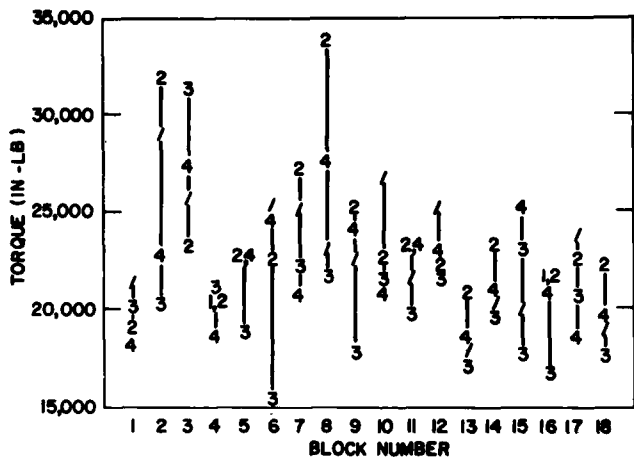

Figure 11.—Torque developed with each chuck on each block (Douglas-fir).

(M 149 931)

that it would have been discovered through a trial and error process involving literally millions of trials. With this in mind, it was anticipated that the work would verify the assumption that chuck size was the only important torque-determining factor. The results of the testing, however, show that a significant difference in transmitted torque exists for chucks with the same size but different spur configurations.

Lutz and Patzer first presented the concept that spin-out occurs with a predominantly rolling shear failure in a cylinder the diameter of the chuck and somewhat deeper than the length of the spurs (9). The torque transmitted to the log is then a function of the size, both diameter and depth, of the chuck and the rolling shear strength of the wood. While this explains why larger chucks with longer spurs can transmit more torque, it does not predict nor explain any torque difference in chucks the same size but with different spur configurations. However, by examining the failure mechanism in more detail and carrying the rolling shear theory one step further, it becomes clearer that spur configuration also affects deliverable torque. The torque is transmitted from the chucks to the log through a complex combination of bending, rolling, and transverse shear with rolling shear predominating. The area over which the rolling shear acts is not the entire cylindrical area previously described, but rather that area less the profile area of the spurs at the circumference of the chuck. That is, the torque can be transmitted only through the effective or net area. Anything that reduces this area, such as smaller chuck diameter, short spur length, or increased spur profile area, will result in a reduction in the area over which the load can be transmitted. This, in turn, increases the shear stress acting on the material. Because spin-out occurs when the material fails—that is, when the ultimate shear strength of the material is exceeded—anything that increases the shear stress will result in a

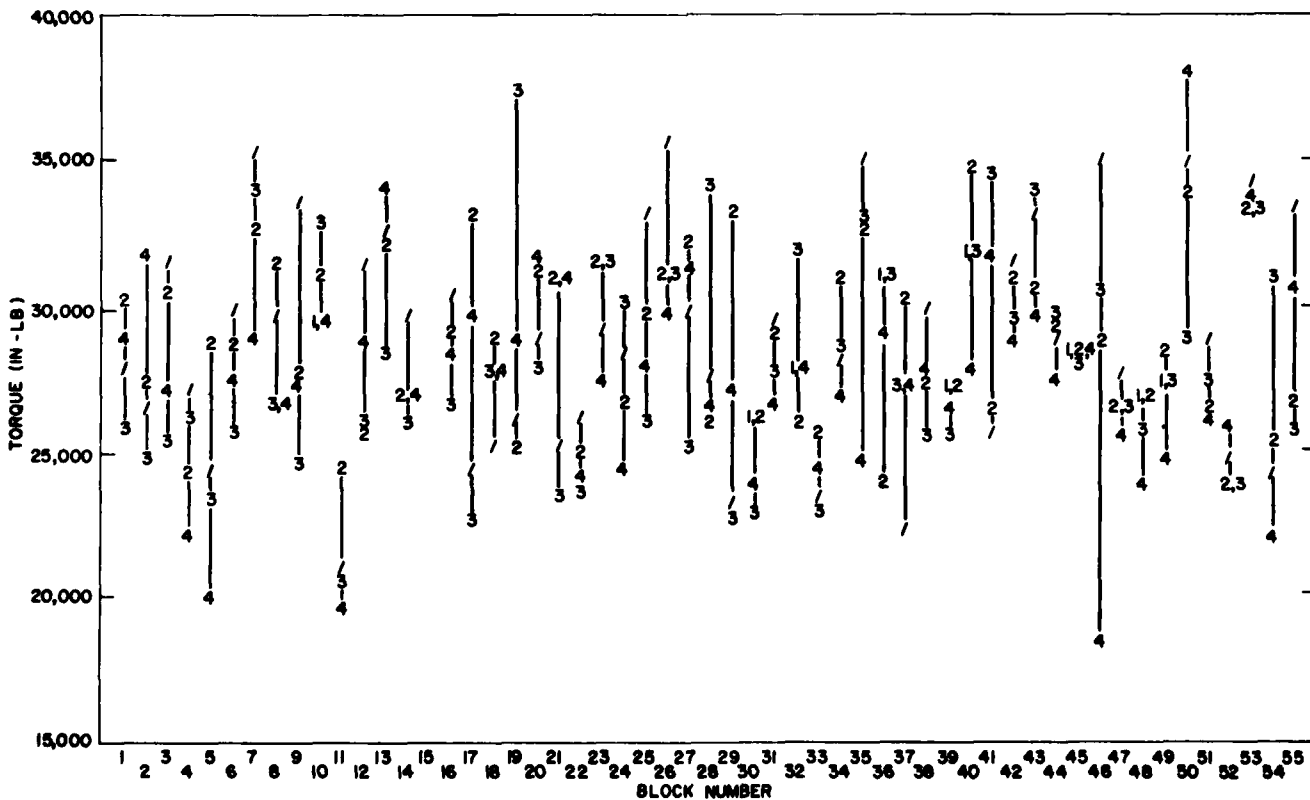

Figure 12.—Torque developed with each chuck on each block (white fir).

(M 149 936)

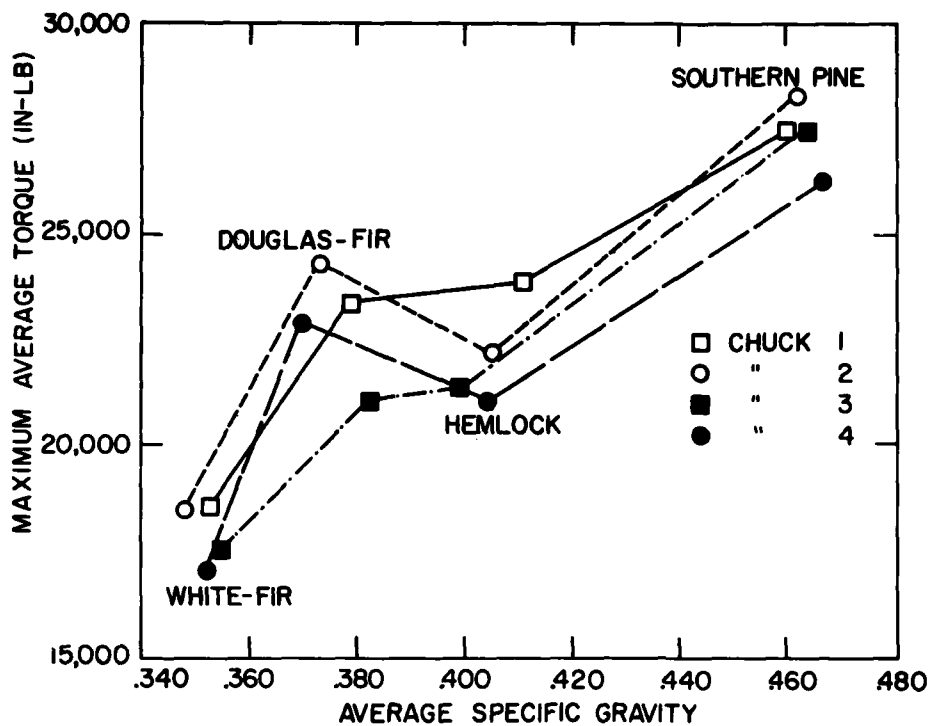

Figure 13.—Maximum average torque developed with each chuck type on each species, in order of increasing specific gravity. (M 149 932)

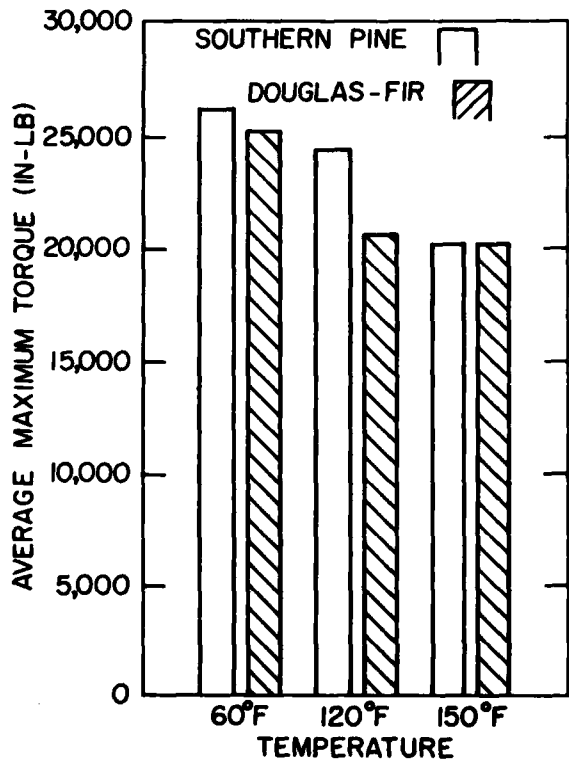

Figure 14.—Average maximum torque developed on southern pine and Douglas-fir blocks at three different temperatures. Twenty samples were taken, five at each spur penetration depth: 1, 1-1/2, 2-1/4, 3-1/4 inches. (M 149 933)

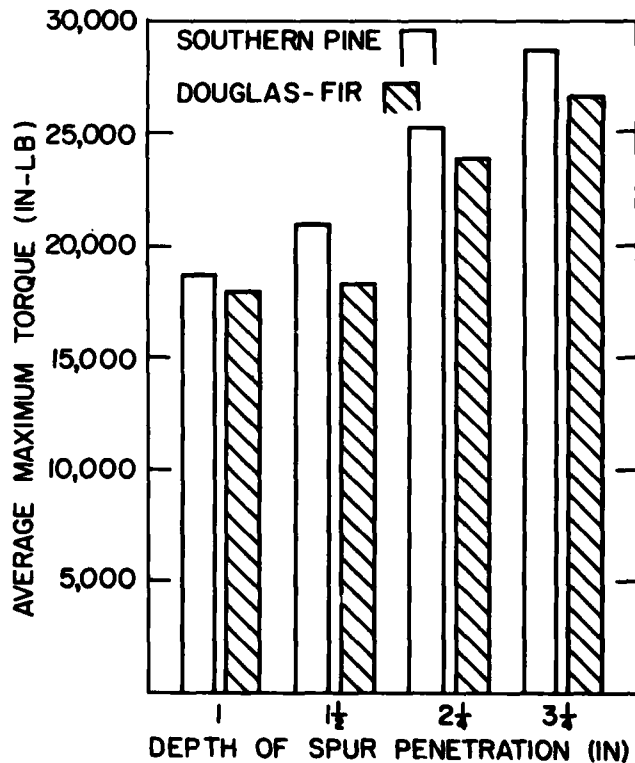

Figure 15.—Average maximum torque developed in southern pine and Douglas-fir at four spur penetration depths. Fifteen samples were taken, five at each of three temperatures: 60° F, 120° F, 150° F. (M 149 934)

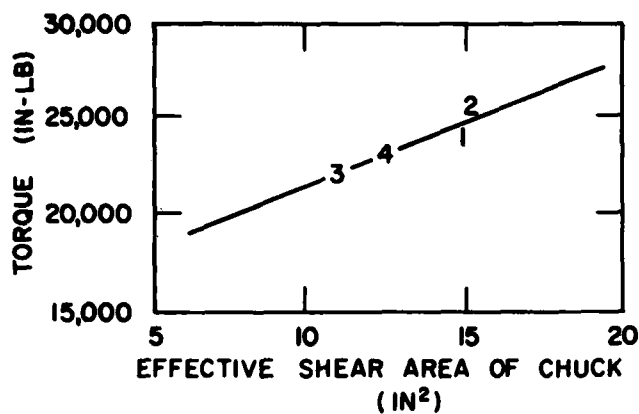

Figure 16.—Effect of shear area on spin-out torque for four chucks in Douglas-fir.

(M 149 935)

reduction in the torque able to be transmitted from the chucks to the blocks. By reducing the area over which the load is carried, the shear stress is increased accordingly. Based on this explanation we would expect chucks with similar spur profiles or, more precisely, approximately equal spur profile areas, to exhibit similar torque-transmitting characteristics. Also, chucks with comparatively large spur profile areas would have a reduced effective area through which the load is transmitted, and they would be expected to fail at lower torque values.

The similarities between chucks 1 and 2 and between 3 and 4, thus, become apparent. An investigation of the failed blocks did not show any apparent significant difference in the failed shear area depth from chuck to chuck. If this is a relative constant, the relationship between the remaining shear area—i.e., net shear area—and the maximum torque developed is informative (fig. 16). Again, profile areas—thus the net effective shear areas—of chucks 1 and 2 are approximately the same and are smaller than the areas of chucks 3 and 4. By distributing the load over a larger area, greater torque can be transmitted before the ultimate shear stress is reached and failure occurs.

Chuck Design Criteria

With this information, criteria for effective chuck design can be developed. These principles for developing maximum torque can be simply stated:

1. Maximum torque increases with increased chuck diameter.
2. Longer spurs increase deliverable torque.
3. Chucks with relatively slender spurs develop higher torque than chucks with large profile spurs.

Other considerations—such as self-cleaning—are obviously important.

While long, slender spurs are desirable for developing maximum torque, it is essential that they be designed for strength and toughness as well. If the chucks are

hardened too much, they will be relatively brittle. Small deflections can result in high stresses and thus failure. This can be a problem because it is necessary for all the spurs to share the load. This is accomplished by individual spurs deflecting somewhat. With brittle material, these small deflections can cause failure of individual spurs long before the maximum torque is developed. Based on actual use, a hardness of approximately 45 on the Rockwell C scale appears optimum. This provides the optimum combination of strength, ductility, and toughness.

It is clear that the experimental chuck (fig. 7) utilizes relatively long, slender spurs. While its durability may be questioned, it is certainly effective at transmitting torque. When tested at its maximum depth of penetration, 3-1/4 inches, this chuck exhibited significantly greater torque than any of the other four chucks tested, even though its diameter is smaller. In spite of its smaller diameter, the effective shear area is greater than any other chuck tested. Thus it is not surprising that it delivered more torque before spin-out occurred. If in practice this chuck design proves to not be durable enough, minor changes—such as adding a stiffening web to the spurs or changing the shape of the spurs to provide a more uniform stress distribution along the length of the spur—can be made without seriously compromising its effectiveness.

The torque required during peeling is highly variable. As discussed earlier, it is a product of the cutting force and the block radius at any time. The cutting force is highly variable and among the factors that influence it are species, density, presence of knots, and log conditioning. In designing chucks for strength, the maximum load that they will encounter must be considered. In any case, the maximum torque that can be delivered is the spin-out torque. Chucks should be designed, after providing for fatigue and a suitable factor of safety, to withstand either the maximum required torque or the maximum spin-out torque, whichever is smaller. No reliable broadly based data on required torque are available. Lacking these data, a reasonable criterion for strength can be obtained using the values for maximum spin-out torque (table 2). Using these values should result in a chuck that has adequate strength to resist breaking and adequate stiffness to resist permanent deformation.

Additional Considerations

One aspect of chuck design that affects spin-out rate is the size relationship between the inner and outer chucks. The use of large-diameter, and thus large-capacity, outer chucks obviously provides substantial torque when peeling begins. While this reduces the likelihood of early spin-out, the use of too-large chucks can increase the likelihood of spin-out occurring when these outer chucks are retracted. Because the large outer chuck must be retracted with the log at a relatively large diameter, the torque required from the inner chucks is relatively large. This increases the chance of spin-out occurring when the outer chuck is withdrawn.

Table 1.—Number of occurrences¹ of maximum torque for four species and four chucks

Chuck No.	Occurrences of maximum torque in			
	18 Douglas-fir bolts	39 Southern pine bolts	55 White fir bolts	22 Western hemlock bolts
1	6	8	26	11
2	10	21	20	9
3	2	8	13	2
4	3	6	8	3

¹ Total numbers of occurrences for each species are greater than total numbers of bolts; when more than one chuck had the same torque value, each chuck was considered to have provided maximum torque.

Table 2—Average maximum spin-out torque for four species and four chucks

Chuck No.	Average maximum torque			
	Douglas-fir	Southern pine	White fir	Western hemlock
	in.-lb			
1	23,369	27,473	16,535	23,882
2	24,249	28,131	16,368	22,198
3	21,026	27,326	17,582	21,319
4	22,784	26,154	17,143	21,026

Because the size of the inner chuck is usually determined by the desired core size, the size of only the outer chuck can be optimized. This optimum size depends on all of the factors influencing cutting force and deliverable torque. One of the critical elements is initial block diameter. Large-diameter blocks will require relatively large chucks to reduce initial spin-out when the chucks are withdrawn. Where the typical block diameters are smaller, smaller outer chucks should reduce the probability of spin-out occurring when the outer chucks are withdrawn.

Sufficient data are not available to accurately predict spin-out rate for various log sizes and chuck sizes. A possible way of optimizing outer chuck size is to compare the value of material and time lost due to initial spin-out to spin-out that occurs when the outer chucks are retracted. If the value lost due to spin-out after the outer chucks are retracted is relatively large, then the outer chucks are too large. On the other hand, if relatively little spin-out occurs when the outer chucks are withdrawn, and substantial initial spin-out occurs, then the outer chucks should be increased in capacity. The same criteria described for optimizing chuck design pertain to both inner and outer chuck design. By

using more efficient outer chucks the size can be limited, thus reducing the likelihood of spin-out occurring at any time.

Summary

A substantial test program was conducted to compare the maximum torque deliverable by four different chucks in Douglas-fir, southern pine, white fir, and western hemlock. A fifth chuck was tested in Douglas-fir and southern pine to determine the effects of spur penetration and block temperature on spin-out torque. Based on the results of these tests, some criteria for rational chuck design have been established. Chucks with relatively slender spurs can transmit greater torque before spinning out than can chucks with spurs with relatively large circumferential surface profiles. Maximum torque generally increases with depth of penetration. Therefore, chucks with relatively long, slender spurs are most effective at transmitting torque. The limiting factors are spur strength and stiffness. While slender spurs are desirable they must have sufficient strength to transmit the maximum torque without failure. The yield strength of the spurs must be high enough to prevent permanent deformation of the spurs

to occur. At the same time, however, the material must be sufficiently ductile to allow load sharing among the spurs.

By using properly designed chucks, it appears that a substantial increase in maximum torque can be obtained. This in turn can have a dramatic effect in reducing spin-out rate, at only a minimal cost.

Literature Cited

1. Feihl, O.
1968. Design and performance of roller pressure bar for veneer lathes. Can. Dep. For. Rural Dev. Publ. 1225., Ottawa, Ont.
2. Feihl, O., and V. Godin.
1975. Heating veneer logs. Can. For. Serv., For Tech. Rep. 9. Eastern For. Prod. Lab., Ottawa, Ont.
3. Fraser, H. R.
1975. Recovery up at a Swedish plymill. World Wood 16(3):13-15.
4. Hancock, W. V.
1977. Improvements in veneer yields through better peeling techniques. In Modern Plywood Techniques, Proc. 5th Plywood Clinic [Portland, Oreg.] Miller-Freeman Publ. Co., San Francisco.
5. Kollmann, F., and H. Geschwandtner.
1954. Measuring work of a veneer peeler. Gr. Br. FPRL, Transl. No. 28. For. Prod. Res. Lab., Princes Risborough, Bucks., England.
6. Lutz, J. F.
1960. Heating veneer bolts to improve quality of Douglas-fir plywood. USDA For. Prod. Lab. Rep. No. 2182. For. Prod. Lab., Madison, Wis.
7. Lutz, J. F.
1967. Research at Forest Products Laboratory reveals that heating southern pine bolts improves veneer quality. Plywood Panel 7(9):20-28.
8. Lutz, J. F.
1978. Wood veneer: Log selection, cutting, and drying. USDA For. Serv. Tech. Bull. No. 1577.
9. Lutz, J. F., and R. A. Patzer.
1976. Spin-out of veneer blocks during rotary cutting of veneer. USDA For. Serv. Res. Pap. FPL 278. For. Prod. Lab., Madison, Wis.
10. Peters, C. C., R. R. Zenk, and A. Mergen.
1968. Effects of roller-bar compression and restraint in slicing wood 1-inch thick. For. Prod. J. 18(1):25.
11. Sugiyama, S.
1977. Fundamental studies on stress distribution and frictional behavior on interface between tool and chip in veneer cutting. I. J. Japan Wood Res. Soc. 23(10):472-479.
12. U.S. Forest Products Laboratory.
1974. Wood handbook: Wood as an engineering material. Ch. 3. p. 3-19. USDA Agric. Handb. No. 72.
13. U.S. Forest Products Laboratory.
1974. Wood handbook: Wood as an engineering material. Ch 4. p. 4-33. USDA Agric. Handb. No. 72.
14. Walser, D. C.
1978. New developments in veneer peeling. In Modern Plywood Techniques, Proc. 6th Plywood Clinic [Portland, Oreg.] Miller-Freeman Publ. Co., San Francisco.

U.S. Forest Products Laboratory

Influence of chuck design on spin-out torque in soft-wood veneer peeling blocks, by Frank J. Fronczak and Robert A. Patzer, FPL, Madison, Wis., 1982.

15 p. (USDA For. Serv. Res. Pap. FPL 427)

Five chuck configurations were used to determine maximum torque deliverable to peeling blocks of four species. Chucks with relatively slender spurs transmitted greater torque before spinning out than did chucks with large

END

FILMED

1-83

DTIC