

AD-A122 757

A RADIO FREQUENCY OSCILLATOR TECHNIQUE FOR MEASURING
PROJECTILE TRANSVERS... (U) ARMY ARMAMENT RESEARCH AND
DEVELOPMENT COMMAND ABERDEEN PROVI... J Q SCHMIDT

1//

UNCLASSIFIED

NOV 82 ARBRL-TR-02448 SBI-AD-F300 137

F/G 19/1

NL .

END
DATE
FILMED
DTIC

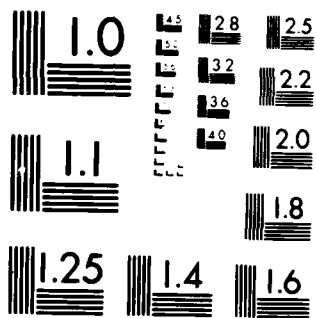

MICROCOPY RESOLUTION TEST CHART
NATIONAL BUREAU OF STANDARDS 1963-A

AD-F300137

12

AD

ADA122757

TECHNICAL REPORT ARBRL-TR-02448

A RADIO FREQUENCY OSCILLATOR TECHNIQUE
FOR MEASURING PROJECTILE TRANSVERSE
DISPLACEMENT AT MUZZLE EXIT

Jimmy Q. Schmidt

November 1982

DTIC
SELECTED
DEC 22 1982
S H D



US ARMY ARMAMENT RESEARCH AND DEVELOPMENT COMMAND
BALLISTIC RESEARCH LABORATORY
ABERDEEN PROVING GROUND, MARYLAND

Approved for public release; distribution unlimited.

DTIC FILE COPY

82 11 29 062

Destroy this report when it is no longer needed.
Do not return it to the originator.

Secondary distribution of this report is prohibited.

Additional copies of this report may be obtained
from the National Technical Information Service,
U. S. Department of Commerce, Springfield, Virginia
22161.

The findings in this report are not to be construed as
an official Department of the Army position, unless
so designated by other authorized documents.

*The use of trade names or manufacturers' names in this report
does not constitute endorsement of any commercial product.*

UNCLASSIFIED

SECURITY CLASSIFICATION OF THIS PAGE (When Data Entered)

REPORT DOCUMENTATION PAGE		READ INSTRUCTIONS BEFORE COMPLETING FORM	
1. REPORT NUMBER Technical Report ARBRL-TR- 02448	2. GOVT ACCESSION NO. AD-A122	3. RECIPIENT'S CATALOG NUMBER 757	
4. TITLE (and Subtitle) A RADIO FREQUENCY OSCILLATOR TECHNIQUE FOR MEASURING PROJECTILE TRANSVERSE DISPLACEMENT AT MUZZLE EXIT		5. TYPE OF REPORT & PERIOD COVERED	
		6. PERFORMING ORG. REPORT NUMBER	
7. AUTHOR(s) JIMMY Q. SCHMIDT		8. CONTRACT OR GRANT NUMBER(s)	
9. PERFORMING ORGANIZATION NAME AND ADDRESS U.S. Army Ballistic Research Laboratory ATTN: DRDAR-BLI Aberdeen Proving Ground, MD 21005		10. PROGRAM ELEMENT, PROJECT, TASK AREA & WORK UNIT NUMBERS 1L162618AH80	
11. CONTROLLING OFFICE NAME AND ADDRESS U.S. Army Armament Research & Development Command U.S. Army Ballistic Research Laboratory (DRDAR-BL) Aberdeen Proving Ground, MD 21005		12. REPORT DATE November 1982	
		13. NUMBER OF PAGES 28	
14. MONITORING AGENCY NAME & ADDRESS (if different from Controlling Office)		15. SECURITY CL. ASS. (of this report) UNCLASSIFIED	
		15a. DECLASSIFICATION/DOWNGRADING SCHEDULE	
16. DISTRIBUTION STATEMENT (of this Report) Approved for public release; distribution unlimited			
17. DISTRIBUTION STATEMENT (of the abstract entered in Block 20, if different from Report)			
18. SUPPLEMENTARY NOTES			
19. KEY WORDS (Continue on reverse side if necessary and identify by block number) Projectile Muzzle Exit Transverse Displacement Sensor			
20. ABSTRACT (Continue on reverse side if necessary and identify by block number) jmk The alignment of a projectile or projectile subcomponent relative to the gun tube axis at muzzle exit is a very important parameter to be considered in gun system investigation. The angle and magnitude of the displacement are usually quite small and can only be obtained by extremely complex instrumentation. Described in this report is a radio frequency oscillator technique which will provide a simple and reliable means for the measurement of the projectile displacement. A four segment sensor arrangement which forms part of a radio (continued on next page)			

DD FORM 1 JAN 73 1473

EDITION OF 1 NOV 65 IS OBSOLETE

UNCLASSIFIED

SECURITY CLASSIFICATION OF THIS PAGE (When Data Entered)

UNCLASSIFIED

SECURITY CLASSIFICATION OF THIS PAGE(When Data Entered)

frequency oscillator circuit is mounted on the muzzle of the gun. Each segment is responsive to the passage of the projectile, with its output proportional to the proximity of the projectile to the individual sensor segments. By properly combining the detected signals, the horizontal and vertical components of the projectile displacement can be measured. From this, the angle and magnitude of the projectile or projectile subcomponent displacement relative to the gun tube axis can be derived.

SECURITY CLASSIFICATION OF THIS PAGE(When Data Entered)

TABLE OF CONTENTS

	Page
LIST OF ILLUSTRATIONS	5
I. INTRODUCTION	7
II. DESCRIPTION OF THE PROJECTILE TRANSVERSE DISPLACEMENT MEASUREMENT SYSTEM	8
III. INITIAL TEST RESULTS OF THE PROJECTILE TRANSVERSE DISPLACEMENT MEASURING SYSTEM ON A 40-mm GUN.	15
IV. SUMMARY	23
REFERENCES	24
DISTRIBUTION LIST	25

Accession For	
NTIS GRA&I	<input checked="" type="checkbox"/>
DTIC TAB	<input type="checkbox"/>
Unannounced	<input type="checkbox"/>
Justification	
By _____	
Distribution/	
Availability Codes	
Dist	Avail and/or Special
A	



LIST OF ILLUSTRATIONS

Figure	Page
1. The Basic Sensor Coil Arrangement.	9
2. Cross-Sectional View of the Sensor Coils Attached to the Gun Tube	9
3. Design of the Four Segmented Sensor With All Loops on the Same Longitudinal Plane	10
4. The Basic Schematic of the RF Oscillator for the Transverse Displacement Sensor.	11
5. Representative Waveforms of A Projectile Aligned in the Horizontal Plane and Cocked in the Vertical Plane.	12
6. Block Diagram of the Signal Processing Circuits and Associated Waveforms.	12
7. The Complete Transverse Displacement Sensor and Amplifier Assembly	14
8. Physical Configurations of the Test Projectile	16
9. Recorded Signals of Round 81, First Modified Projectile.	17
10. X-ray Photograph of the First Modified Projectile.	18
11. X-ray Photograph of the Second Modified Projectile	18
12. Recorded Signals of Round 82, Second Modified Projectile	19
13. X-ray Photograph of the Third Modified Projectile.	20
14. Recorded Signals of Round 83, Third Modified Projectile.	21
15. Recorded Signals of Round 84, Fourth Modified Projectile	22
16. X-ray Photograph of the Fourth Modified Projectile	23

I. INTRODUCTION

Among the many parameters to be considered relating to gun system accuracy is the launch orientation of the projectile relative to the gun tube axis. Excessive misalignment of the projectile at muzzle exit can affect the free flight trajectory of the projectile and thus the accuracy. The misalignment of the projectile is also indicative of gun tube wear and other projectile-gun tube interface problems. Knowledge of the orientation characteristics of the projectile could result in refinement of the projectile design to provide increased accuracy. With increased emphasis on high performance gun-projectile systems, knowledge of the forces affecting the structural integrity of the projectile at launch becomes increasingly important. Projectiles for these systems are quite expensive. If design or structural defects can be detected early in the development phase, they may be corrected resulting in an overall cost savings, increased reliability, and accuracy of the system.

During the past one and one-half years considerable research has been conducted using a radio frequency technique to measure projectile muzzle velocity.^{1,2} Radio frequency velocimeters have been used on a 40-mm, 75-mm, and 105-mm gun primarily to obtain a real time measurement of projectile muzzle velocity. However, analysis of the records of the detected projectile signature has shown that the radio frequency technique can provide measurements of other interior ballistic parameters before, during, and after muzzle exit. In order to provide an accurate and reliable muzzle velocity measurement, the signal modulation caused by these parameters had to be considered extraneous and suppressed as much as possible. Now that these signals have successfully been suppressed to provide muzzle velocity measurements, it is logical to pursue the other applications of the radio frequency technique to complement the velocity measurements.

Recorded signals of some projectiles have shown the radio frequency technique to be capable of detecting small projectile deformation and misalignment as it exits the gun tube. However, since the sensor coil used in the velocimeter system is a single loop, the detected signal is the total integrated signal representing the proximity of the projectile to the sensor over a full 360° arc. Even though the projectile misalignment may be evident, it is not possible to extract the angle or magnitude of the misalignment from the signal.

Described in this report is a radio frequency technique which provides a means to obtain the angle and the magnitude of the displacement of the projectile with respect to the bore axis at the precise instant of projectile exit. It also provides a means to monitor the structural integrity of the projectile at muzzle exit.

Due to the projectile and gun tube tolerances, the displacement from the bore axis is quite small unless the projectile is physically deformed during

¹ Jimmy Q. Schmidt, "A Radio Frequency Oscillator Technique for Measuring Projectile Muzzle Velocity," ARBRL-TR-02158, April 1979.

² Rurik K. Loder, Jimmy Q. Schmidt, "Radio Frequency Oscillator Technique for Monitoring Velocity and Structural Integrity of Projectiles During Their Exit From the Muzzle," ARBRL-MR-03100, April 1981.

its travel in the gun tube. In the past, this small displacement has been difficult to measure since a small displacement is difficult to detect by photographic methods. X-ray photographs are usually not sufficiently well defined to see this small displacement. Using regular photography, the projectile may be obscured by the smoke and blast in the muzzle region. Although the use of an optical lever may be possible, it is likely that the smoke and blast would attenuate the light beam making measurements difficult. The same is true with a multiple interferometry system. All of the above methods are relatively expensive and require a fixed mounting with realignment necessary if the firing angle is changed.

The radio frequency oscillator displacement measuring system has several distinct advantages over the aforementioned methods:

- A. It is more sensitive to small amounts of displacement. Displacement on the order of 0.1 mm (0.005 in.) can be measured.
- B. It is easily integrated into a small computer system for the computation of the angle and magnitude of the displacement.
- C. The sensor and its associated circuitry are simple and inexpensive.
- D. There is no restriction to the firing angle of the gun since the sensor is mounted at the face of the muzzle.

II. DESCRIPTION OF THE PROJECTILE TRANSVERSE DISPLACEMENT MEASUREMENT SYSTEM

The projectile transverse displacement measuring system consists basically of:

- A. A multisegmented active inductance coil, in this design a four-segmented arrangement where one pair of semicircular segments is oriented in a horizontal plane and the other pair displaced by 90° to be in a vertical plane.
- B. A radio frequency oscillator to excite the sensor segments and provide a sensor responsive to the passage of the projectile.
- C. An amplitude detector associated with each segment to remove the radio frequency carrier and provide a pulse, the amplitude of which is proportional to the transverse displacement of the projectile with respect to the sensor segment as the projectile passes the sensor.
- D. A pair of wide band differential amplifiers which amplify the difference between the detected signals of the corresponding horizontally and vertically oriented segments.
- E. A pair of summing amplifiers which sum the detected signals of the corresponding sensor segments.
- F. A pair of two-channel digital oscilloscopes to record and transfer the signals to a computer for the computation of the angle and magnitude of the projectile displacement.

A simple four-segment sensor was used in the initial test of the transverse displacement measurement system. The choice of the number of segments is dictated by the required sensitivity and resolution of the measurement. To simplify the design, two identical segmented coils were fabricated from standard printed circuit board. The design is shown in Figure 1.

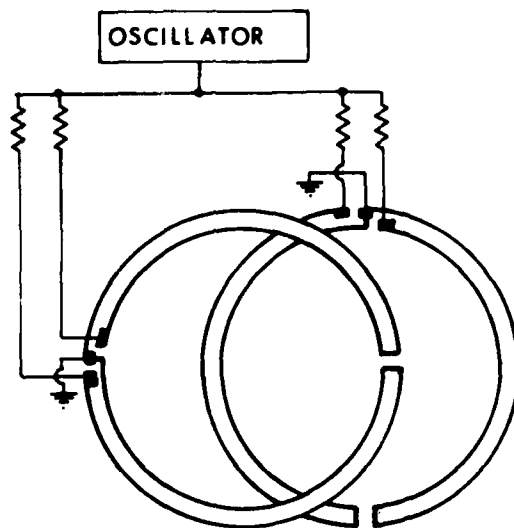

Figure 1. The Basic Sensor Coil Arrangement

The two sensor rings are oriented 90° with respect to each other, epoxied in a mounting collar and bolted to a 40-mm gun tube as shown in Figure 2. A Teflon seal is used between the sensor and gun tube to prevent the high pressure gases from leaking in between the sensor and the gun tube.

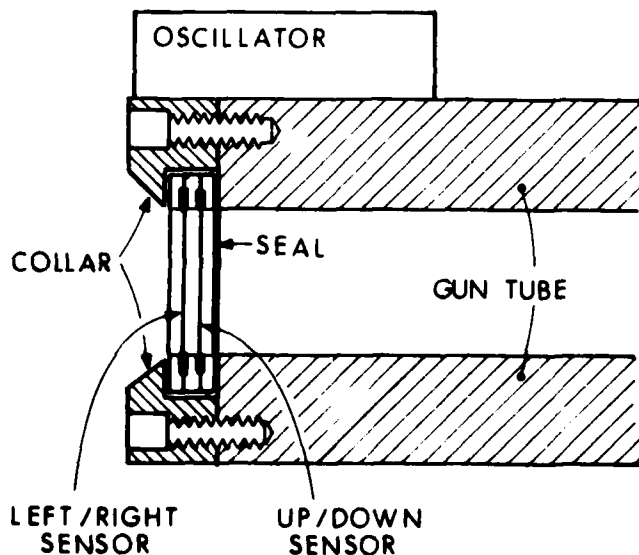

Figure 2. Cross-Sectional View of the Sensor Coils Attached to the Gun Tube

Since the sensor is composed of two rings, there is a slight time difference between the detected signals which must be taken into account in the data analysis. Shown in Figure 3 is a four-segmented sensor coil in which all four segments are in the same longitudinal plane. This eliminates the time differential but has less sensitivity than the original sensor. The simpler, more sensitive, two ring arrangement was chosen for the first test; however, other sensor arrangements such as shown in Figure 5 will be tested at a later time.

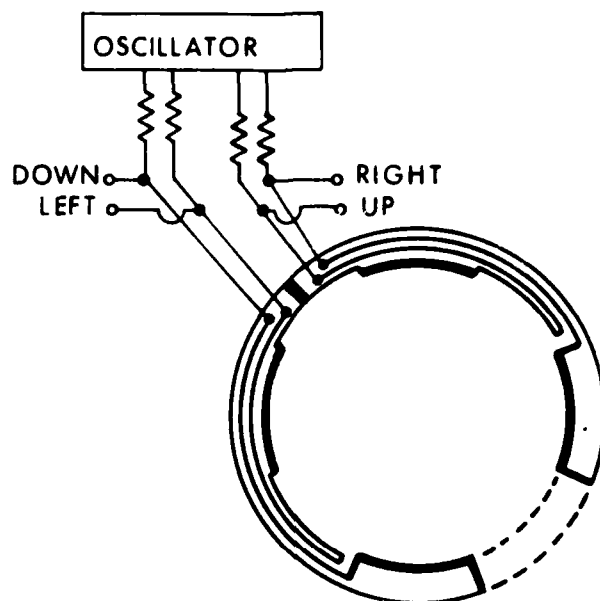

Figure 3. Design of the Four Segmented Sensor With All Loops on the Same Longitudinal Plane

Referring to Figure 1, it can be seen that if the two sensor rings are oriented as shown, one segment of a ring can be used to detect the proximity of the projectile to the left of the center axis of the gun tube while the adjacent segment can be used to detect the projectile's proximity to the right side of the tube axis. With the second sensor ring oriented 90° with respect to the first, one segment detects the "up" displacement while the adjacent segment detects the "down" displacement.

The principle by which a signal is developed in each segment is the same as in the radio frequency muzzle velocimeter.¹ In this application, all four segments of the sensor are part of a radio frequency (RF) oscillator circuit as shown in Figure 4.

Each inductive segment is resonated by a parallel capacitor at approximately the oscillator frequency and is partially isolated by four resistors. An electromagnetic field is radiated from each sensor segment. As the projectile passes, this field induces localized eddy currents in the shell of the projectile which, in turn, couples back into the sensor segments. This

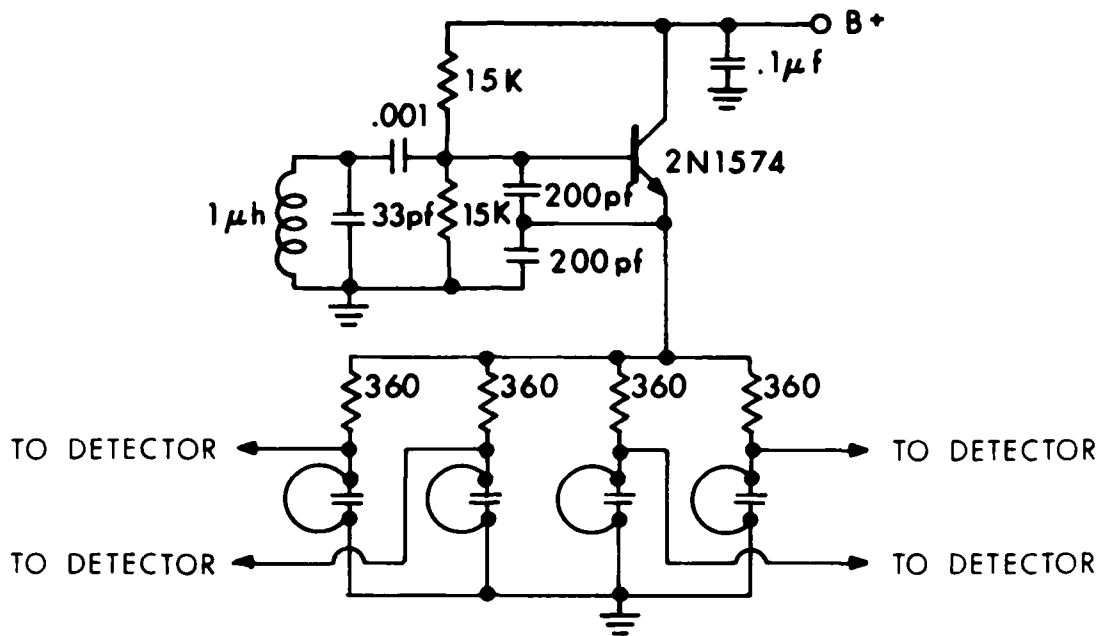

Figure 4. The Basic Schematic of the RF Oscillator for the Transverse Displacement Sensor

causes an impedance transformation which is reflected as a change in the RF level which is across the sensor coil segments. The magnitude of the RF level change is a function of the distance between the sensor segment and the projectile. The closer the projectile is to the sensor segment, the stronger the coupling and the greater the impedance transformation. The resultant change in RF across each segment is amplitude-detected by a conventional diode detector and filtered to remove the RF carrier. As a result of the projectile passing through the sensor, four pulses are generated, the amplitude of each at any given point in time being a function of the distance between the projectile and the sensor segment.

Representative waveforms obtained from a cylindrical projectile are shown in Figure 5. In this example, the projectile is assumed to be perfectly centered and aligned with the gun tube in the horizontal plane (left/right) and cocked, leading edge up, in the vertical plane (up/down). Since the projectile is equidistant from the left and right sensor segments, the amount of amplitude modulation is the same on the left and right sensor segment. After detection and filtering, two positive pulses which are equal to each other are obtained. The two detected pulses are fed to a wide band differential amplifier and a summing amplifier. Since the projectile is cocked in the vertical plane, the leading edge of the projectile will be closer to the "up" segment. The amount of modulation is therefore greater at the leading edge of the modulated signal. As the projectile passes the sensor, the trailing edge will be closer to the "down" segment resulting in greater modulation at the trailing edge of

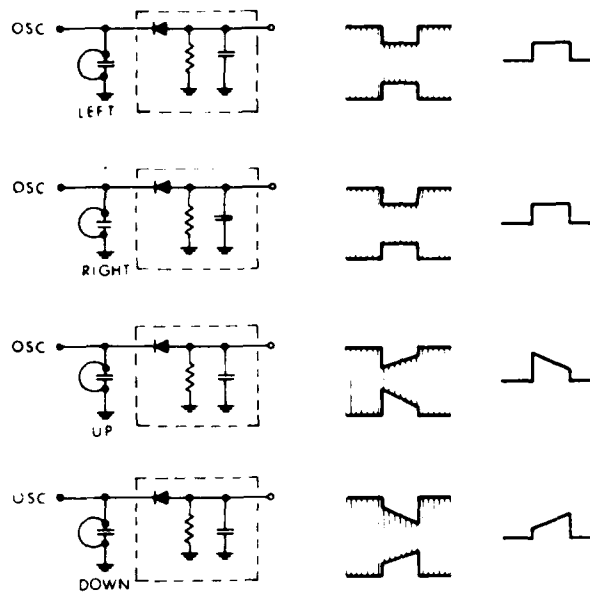

Figure 5. Representative Waveforms of A Projectile Aligned in the Horizontal Plane and Cocked in the Vertical Plane

the signal from the "down" sensor. After detection and filtering, two pulses are obtained and fed to a second wide band differential amplifier and a summing amplifier. The two pulses from the left/right detectors are coupled to the non-inverting and inverting inputs, respectively, of the differential amplifier as shown in Figure 6.

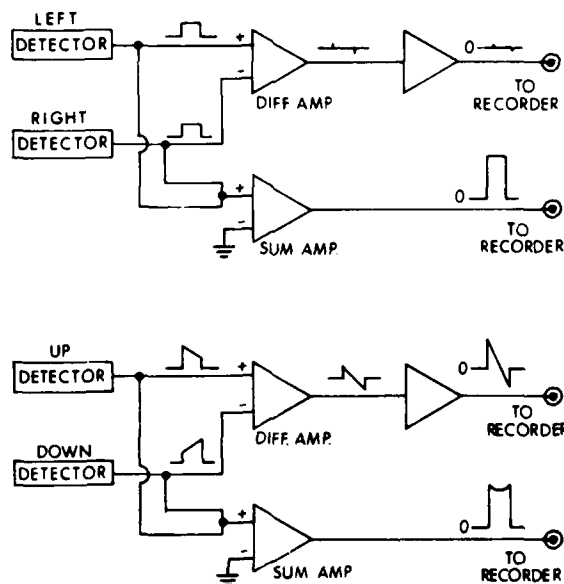

Figure 6. Block Diagram of the Signal Processing Circuits and Associated Waveforms

The signals, being equal are, cancelled in the differential amplifier resulting in no output. If the projectile would have been displaced to the left, a positive output would have been obtained; if it had been displaced to the right, a negative output would have been obtained. A second amplifier provides additional gain for what ever signal is present to increase it to a suitable level for recording. The two pulses are also coupled to a summing amplifier, representing the sum of the two input signals. Thus, two output pulses are obtained from the left/right channel. The first one is the difference signal, the polarity of which indicates the direction of projectile displacement relative to the center axis of the gun tube. The amplitude of this signal is proportional to the displacement. The second signal, the summed one, is the total integrated signal of both segments and is used for the signal normalization and the computation of projectile velocity.

The two pulses from the up/down detectors are fed to the noninverting and inverting inputs, respectively, of the second wide band differential amplifier. In this example, where the projectile has a misalignment in the vertical plane, the two signals are different. The differential amplifier will cancel the equal component of the signal and amplify any difference. The unequal component of the signal derived from the "up" detector is amplified without phase inversion while the unequal component of the signal from the "down" detector is amplified and inverted by 180°. The output pulse of the differential amplifier is a pulse indicating the misalignment of the projectile. The leading edge of the pulse is positive, gradually decreasing to zero and then to a negative peak and returning to zero after the projectile passes. This corresponds to the projectile being cocked in the vertical plane where the leading edge of the projectile is closer to the "up" segment and the trailing edge of the projectile is closer to the "down" segment of the sensor. This pulse is further amplified for recording. The two pulses from the up/down sensors are also fed to a summing amplifier which provides an output pulse for the normalization of the signal.

In summary, four output signals are obtained

- A. A left/right differenced signal, the polarity being indicative of the left or right displacement of the projectile and the amplitude indicative of the magnitude of the displacement.
- B. An up/down differenced signal, the polarity being indicative of the up or down displacement of the projectile and the amplitude indicative of the magnitude of the displacement.
- C. A summed left/right signal for use in the normalization of the signals.
- D. A summed up/down signal for use in the normalization of the signals.

The circuitry for the sensor oscillator, the detectors, and the amplifiers is housed in a small box attached to the sensor mounting collar. The four output pulses are coupled back to a recording facility on four coaxial cables. The complete assembly is shown in Figure 7. Since the gun was approximately 50 m from the recording room, the four signals were coupled through unity gain isolation amplifiers to prevent 60 Hz modulation due to ground current loops. The left/right summed signal was also fed to the logic circuitry of a radio frequency velocimeter to measure the projectile velocity.

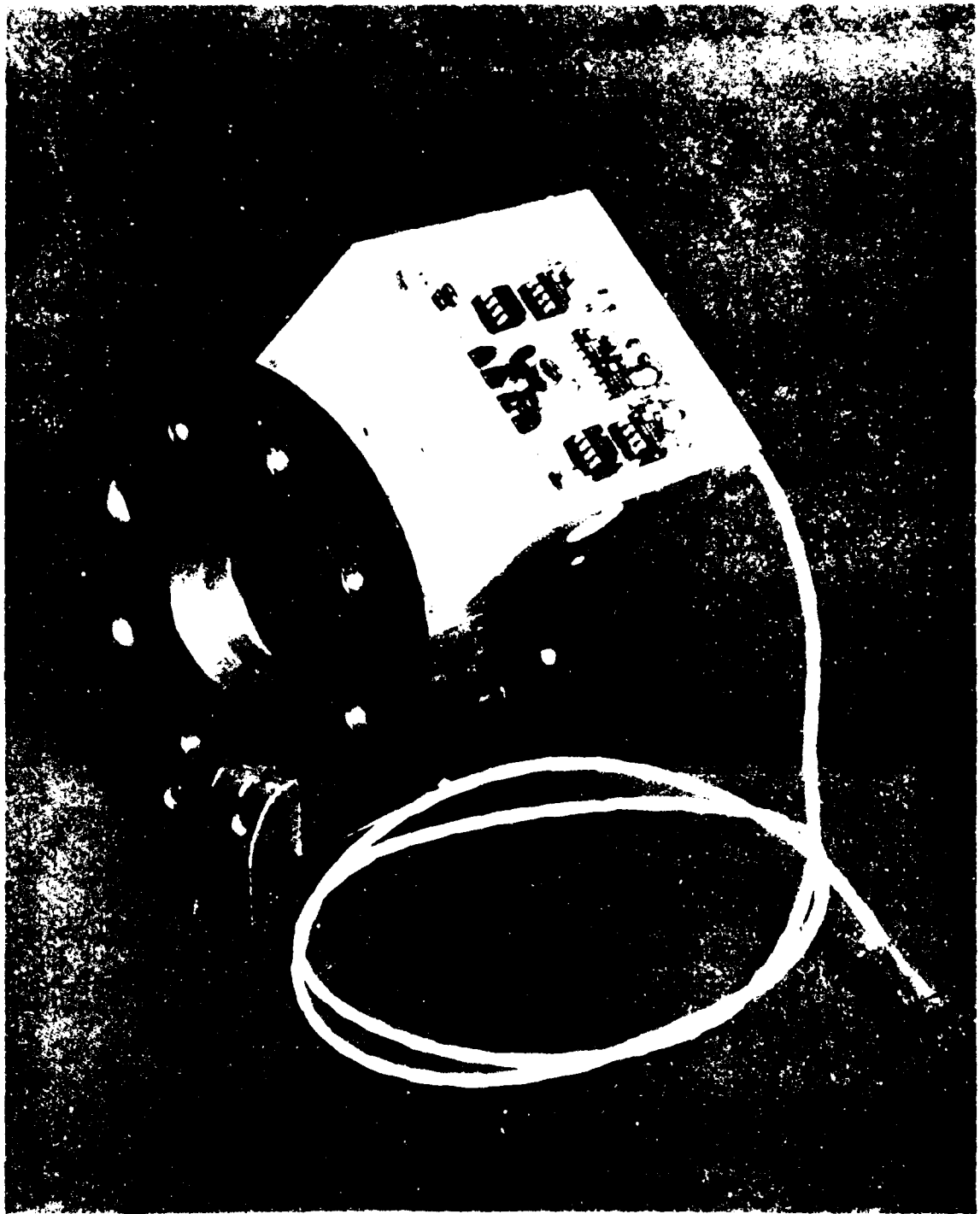

Figure 1. Transverse Displacement of the Cable

III. INITIAL TEST RESULTS OF THE PROJECTILE TRANSVERSE DISPLACEMENT MEASURING SYSTEM ON A 40-mm GUN

The projectile transverse displacement measurement system was tested on a 40-mm smoothbore gun from 26 May 1981 to 11 June 1981. X-ray photographs were taken of the projectiles approximately 30 cm from the muzzle to correlate the angle of displacement observed to the recorded signal. The x-ray photographs were obtained using a new automatic time delay circuit which insures the proper delay time regardless of the projectile velocity.* The real time measurement from the electronic velocimeter is used to calculate the delay to insure capturing the image of the projectile on the x-ray plate.

Since a projectile can be displaced only within the constraints of the projectile and bore tolerances, it is difficult to simulate displacement in a predetermined direction by adding material to one side of the projectile or misaligning it before firing. Asymmetric seating and dynamic effects during in-bore travel can result in unpredictable displacement at muzzle exit. Therefore the projectiles were modified by removing material from one side. This provides the same output result except that the magnitude of the signal is slightly less than if the projectile had actually been closer to the opposite sensor segment. This is due to the nonlinearity of the sensor.

The test projectiles were fabricated in the three sections, a front end piece, a center section called the body, and a rear end piece as shown in Figure 8A. Two plastic bands separate the body from the end pieces.

After several unmodified test projectiles were fired to check out the system, tests were conducted using modified projectiles. In each case, the degree to which the projectile was modified may be considered extreme. However, it guaranteed that the modification could be observed on the x-ray photograph and be employed to confirm the angle of displacement.

The first modified round, Figure 8B, was made by filing two tapered flats on the body. The two flats were filed 90° apart at opposite ends of the projectile. The projectile was loaded in the tube with the leading flat to the right and the trailing flat up. Therefore, the left side in the front was closer to the sensor and the bottom was closer to the sensor in the rear. The recorded signals are shown in Figure 9. A positive or negative signal in the left right channel indicates misalignment to the left or right, respectively, and a positive or negative signal in the up down channel indicates misalignment up or down, respectively. The summed channels provide a signal representing the profile of the projectile. The first pulse is the output from the end piece, the second pulse, the output of the body, and the third pulse, the output of the rear end piece. The signal dropouts between pulses correspond to the plastic bands which are not detected by the radio frequency technique. The x-ray photograph obtained of the projectile is shown in Figure 10.

**Information on the automatic delay circuit will be published in a Ballistic Research Laboratory Report in the near future.*

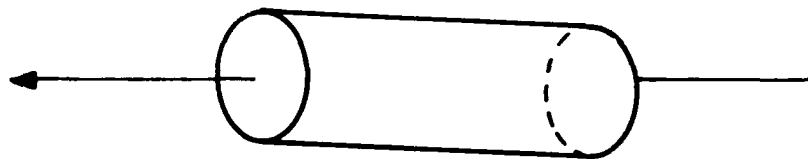
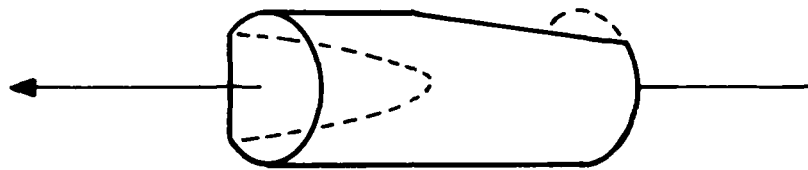
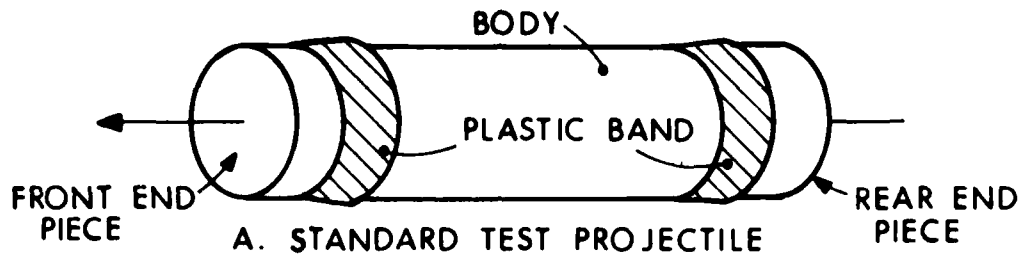

Figure 8. Physical Configurations of the Test Projectile

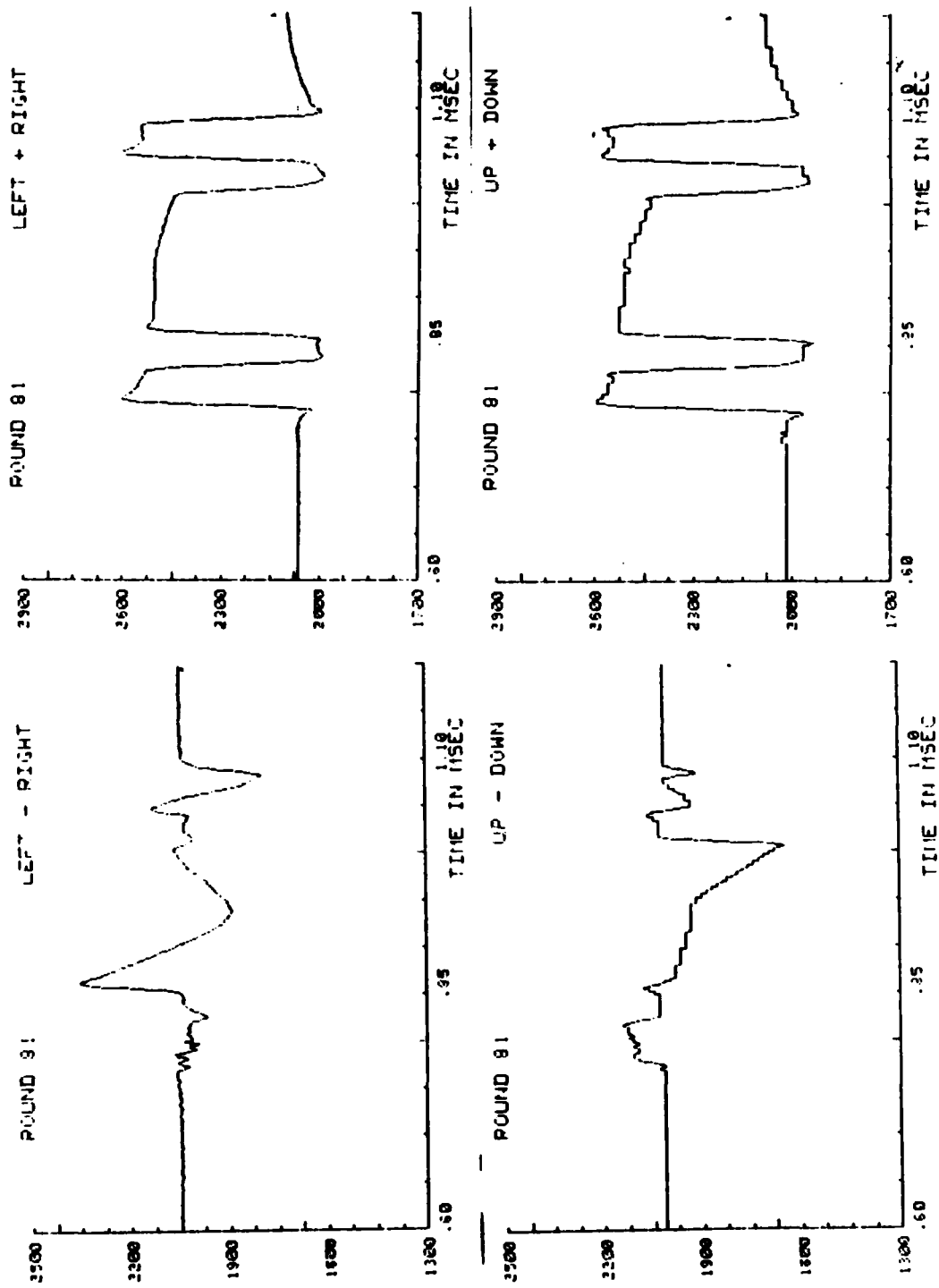

Figure 9. Recorded Signals of Round 81, First Modified Projectile



Figure 10. X-ray Photograph of the First Modified Projectile

In the second example shown, the end pieces had flat spots oriented 180° with respect to each other as shown in Figure 8C. Figure 11 is the x-ray photograph of this projectile. The recorded signals are shown in Figure 12. As can be seen from the records of the left/right channel, the first end piece is well centered and aligned with the tube axis. The body is cocked to the left, and the rear end piece is displaced to the right. In the up/down plane the body is well aligned and the end pieces show a well defined indication of the flat spots. The misalignment of the three sections of the projectile is possible due to the tolerances of the screws holding them together.



Figure 11. X-ray Photograph of the Second Modified Projectile

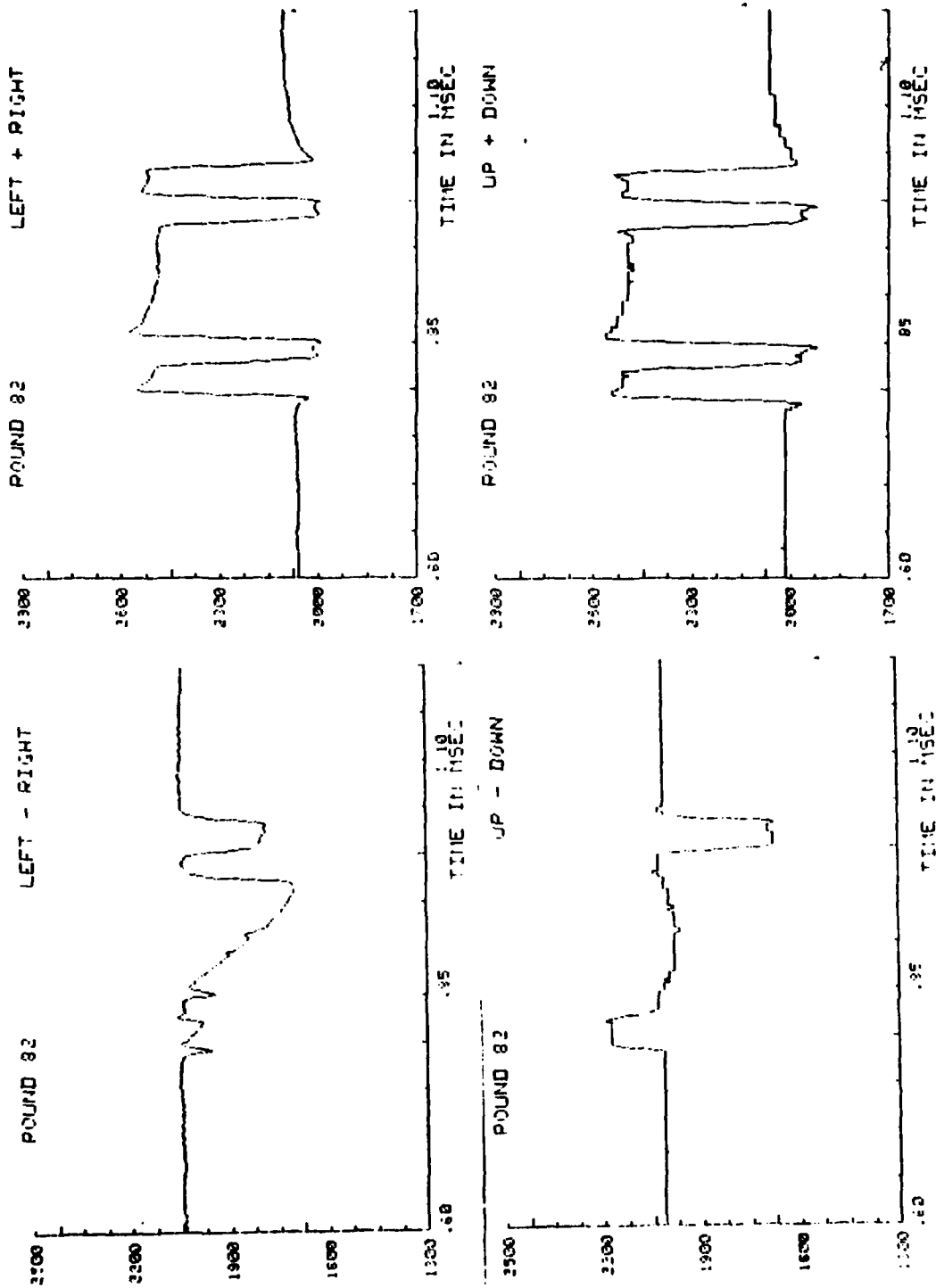

Figure 12. Recorded Signals of Round 82, Second Modified Projectile

The third modified projectile consisted of a body machined down to a smaller diameter and mounted between the end pieces at an angle to the tube axis as shown in Figure 8D. This simulates a cocked projectile, the leading edge up. Shown in Figure 13 is the x-ray photograph of this projectile. The output waveforms are shown in Figure 14. The left right channel indicates that the body of the projectile was displaced to the left. The up down channel shows a clear indication of the inclination of the projectile, where the leading edge of the body was closer to the "up" sensor and the trailing edge of the body was closer to the "down" sensor. It should be noted that the reduced amplitude of the center pulse in the summed channels is a result of the reduced diameter of the body. The reduced diameter was necessary to obtain a simulated cocked projectile.

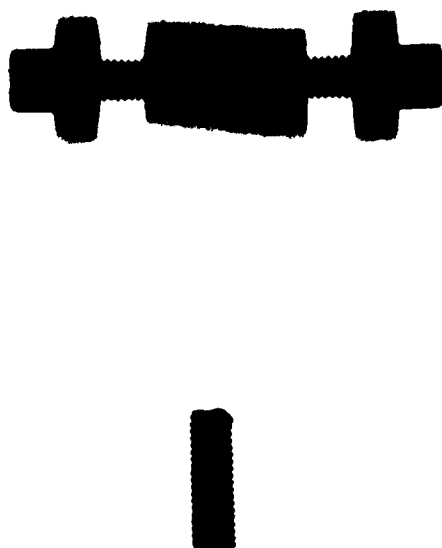

Figure 13. X-ray Photograph of the Third Modified Projectile

A fourth modified projectile is shown in Figure 8E. Three flat steps were filed from the body as shown. The resultant outputs are shown in Figure 15. As can be seen in the left right channel, both end pieces and the body are well aligned with the tube axis. The end pieces are also well aligned in the vertical plane, up down, with the steps on the body being clearly indicated. Figure 16 is the x-ray photograph obtained from this projectile.

As can be seen from these four examples, various forms of misalignment of the projectile or individual projectile components can easily be detected and interpreted using the radio frequency transverse displacement measurement system.

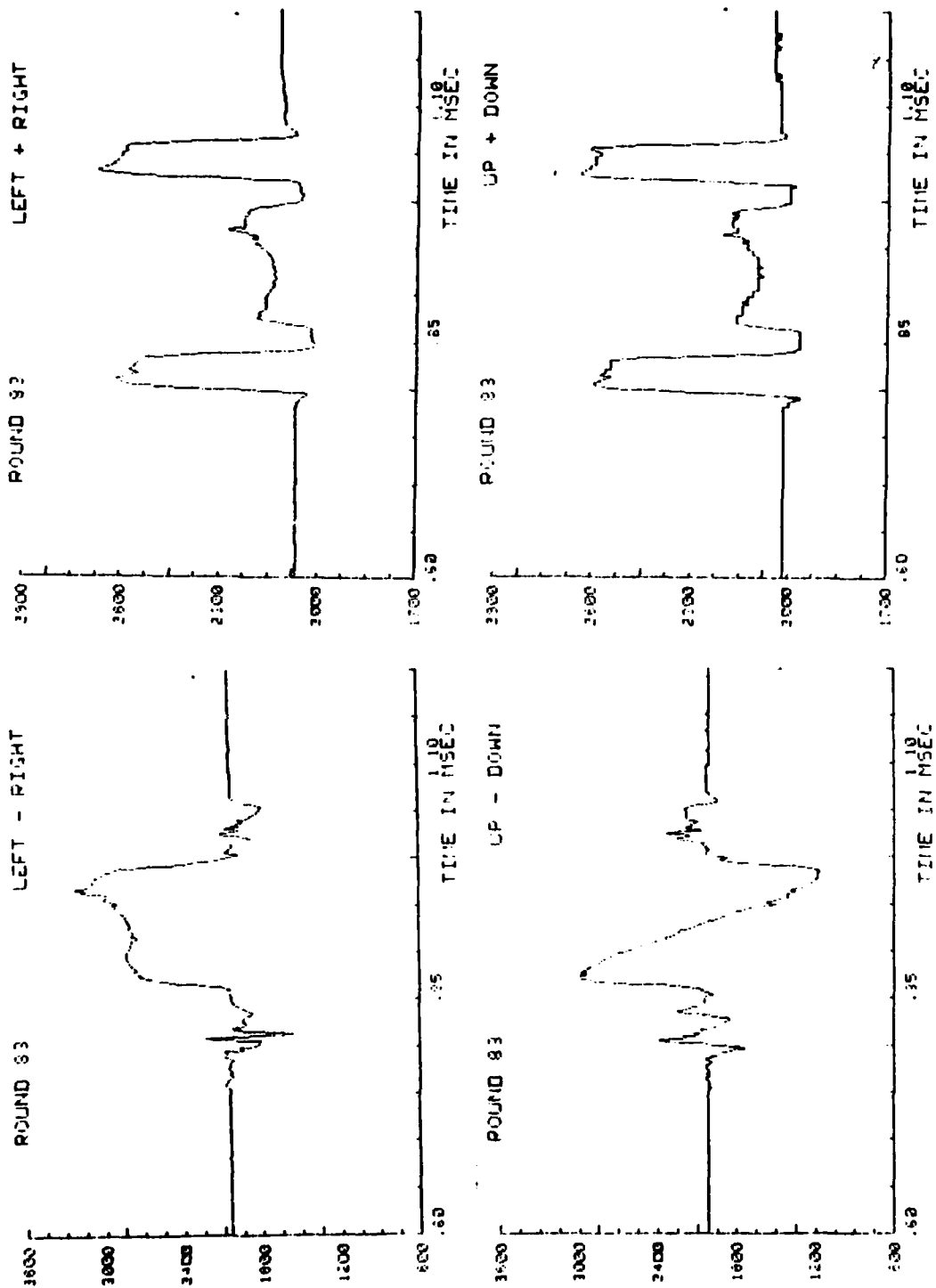

Figure 14. Recorded Signals of Round 83, Third Modified Projectile

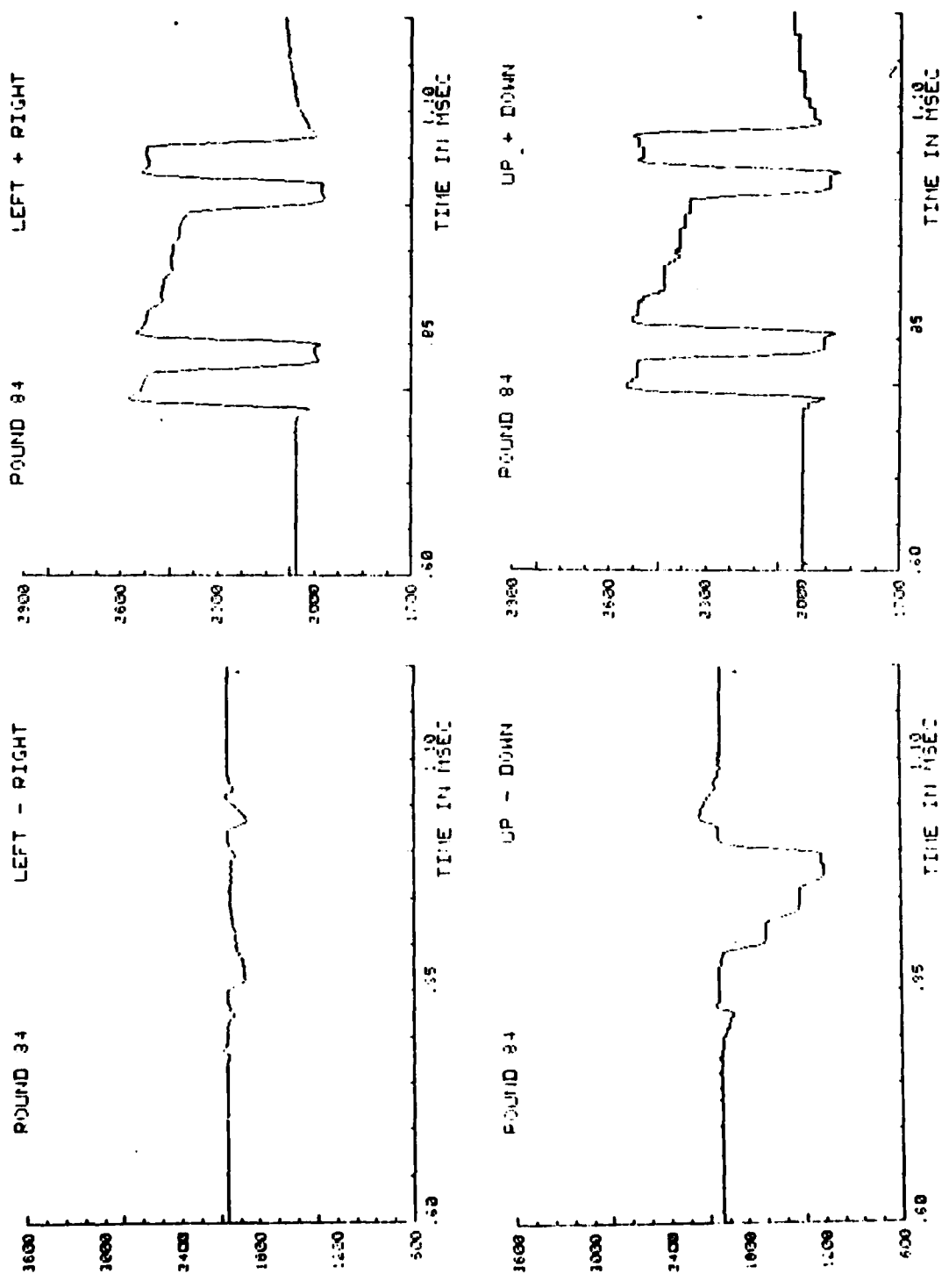

Figure 15. Recorded Signals of Round 84, Fourth Modified Projectile



Figure 16. X-ray Photograph of the Fourth Modified Projectile

IV. SUMMARY

As a result of bench test and the initial test firings of a 40-mm gun with a prototype, the radio frequency technique for measuring projectile transverse displacement has been proven to be a valid concept. This instrumentation should prove to be a valuable asset in the future for the development of projectiles and gun systems. It is highly desirable to apply this technique in the early stage of a projectile or gun development program to define system performance or to detect any projectile-gun interface problems.

At the present time, a computer program is being developed to compute the angle and the magnitude of the displacement relative to the gun tube axis from the horizontal and vertical components recorded.* Additional tests of the projectile transverse displacement measurement system are planned for the near future.

*Results from this and future tests will be published in a future Ballistic Research Laboratory Report.

REFERENCES

1. Jimmy Q. Schmidt, "A Radio Frequency Oscillator Technique for Measuring Projectile Muzzle Velocity," ARBRL-TR-02158, April 1979.
2. Rurik K. Loder, Jimmy Q. Schmidt, "Radio Frequency Oscillator Technique for Monitoring Velocity and Structural Integrity of Projectiles During Their Exit From The Muzzle," ARBRL-MR-03100, April 1981.

DISTRIBUTION LIST

<u>No. of Copies</u>	<u>Organization</u>	<u>No. of Copies</u>	<u>Organization</u>
17	Administrator Defense Technical Info Center ATTN: DTIC-DDA Cameron Station Alexandria, VA 22314	6	Commander USA ARRADCOM ATTN: DRDAR-SC DRDAR-SA DRDAR-SCM DRDAR-SCS DRDAR-SCA DRDAR-SCF Dover, NJ 07801
2	Director Defense Advanced Research Projects Agency 1400 Wilson Boulevard Arlington, VA 22209	2	Commander USA ARRADCOM ATTN: DRDAR-SE Dover, NJ 07801
1	Director Defense Nuclear Agency Washington, DC 20305	2	Commander USA ARRADCOM Product Assurance Directorate ATTN: DRDAR-QA Dover, NJ 07801
1	Commander US Army BMD Advanced Technology Center ATTN: BMDATC-M P.O. Box 1500 Huntsville, AL 35804	2	Commander USA ARRADCOM ATTN: Army Fuze Mgt Project Office DRDAR-FU Dover, NJ 07801
1	Commander US Army Materiel Development and Readiness Command ATTN: DRCDMD-ST 5001 Eisenhower Avenue Alexandria, VA 22333	2	Commander USA ARRADCOM ATTN: Development Project Office for Selected Ammunition DRDAR-DP Dover, NJ 07801
5	Commander USA ARRADCOM ATTN: DRDAR-TSS (2 cys) DRDAR-TDC DRDAR-TDA DRDAR-TDS Dover, NJ 07801	1	Director Benet Weapons Laboratory USA ARRADCOM ATTN: DRDAR-LCB-TL Watervliet, NY 12189
9	Commander USA ARRADCOM ATTN: DRDAR-LCA DRDAR-LCW DRDAR-LCE DRDAR-LCM DRDAR-LCN DRDAR-LCU DRDAR-LC DRDAR-LCS-D, K. Rubin, Maj. J. L. Houle Dover, NJ 07801	1	Commander US Army Rock Island Arsenal ATTN: DRDAR-TSE-SW, R. Radkiewicz Rock Island, IL 61299
		1	Commander US Army Armament Materiel Readiness Command ATTN: DRSAR-LEP-L, Tech Lib Rock Island, IL 61299

DISTRIBUTION LIST

<u>No. of Copies</u>	<u>Organization</u>	<u>No. of Copies</u>	<u>Organization</u>
1	Commander US Army Aviation Research and Development Command ATTN: DRDAV-E 4500 Goodfellow Blvd. St. Louis, MO 63120	1	Commander US Army Missile Command ATTN: DRSMI-RBL Redstone Arsenal, AL 35898
1	Director US Army Air Mobility Research and Development Laboratory Ames Research Center Moffett Field, CA 94035	2	Commander US Army Tank Automotive Research and Development Command ATTN: DRDTA-UL Technical Director Warren, MI 48090
2	Director US Army Research and Technology Laboratories (AVRADCOM) Ames Research Center Moffett Field, CA 94035	2	Commander US Army Jefferson Proving Ground ATTN: STEJP-ID-0, Arnold Tilley STEJP-ID-E, Joseph Tooney Madison, IN 47251
1	Commander US Army Communications Rsch and Development Command ATTN: DRDCO-PPA-SA Fort Monmouth, NJ 07703	2	Commander US Army Yuma Proving Ground ATTN: STEYP-MTW, Robert Torp, Graham Stullenbarger Yuma, AZ 85364
1	Commander US Army Electronics Research and Development Command Technical Support Activity ATTN: DELSD-L Fort Monmouth, NJ 07703	2	President US Army Armor and Engineer Board ATTN: ATZK-RE-CV ATZK-RE-IN, Mr. Larry Smith Fort Knox, KY 40121
3	Commander US Army Harry Diamond Labs ATTN: H. Davis H. Curchack DELHD-S-OE-ES, Ben Banner 2800 Powder Mill Road Adelphi, MD 20783	2	Project Manager Division Air Defense Gun ATTN: DRCPM-ADG Dover, NJ 07801
1	Commander US Army Missile Command ATTN: DRSMI-R Redstone Arsenal, AL 35898	3	Project Manager Cannon Artillery Weapons System ATTN: DRCPM-CAWS Dover, NJ 07801
1	Commander US Army Missile Command ATTN: DRSMI-YDL Redstone Arsenal, AL 35898	2	Project Manager Nuclear Munitions ATTN: DRCPM-NUC Dover, NJ 07801
		2	Project Manager Tank Main Armament Systems ATTN: DRCPM-TMA Dover, NJ 07801

DISTRIBUTION LIST

<u>No. of Copies</u>	<u>Organization</u>	<u>No. of Copies</u>	<u>Organization</u>
1	Product Manager for 30mm Ammo. ATTN: DRCPM-AAH-30mm Dover, NJ 07801	1	Commander Naval Missile Center Point Mugu, CA 93041
2	Product Manager M110E2 Weapon System, DARCOM ATTN: DRCPM-M110E2 Rock Island, IL 61299	2	Commander David W. Taylor Naval Ship Research & Development Center Bethesda, MD 20084
4	Director USA Mechanics and Materials Research Center ATTN: Director (3 cy) DRXMR-ATL (1 cy) Watertown, MA 02172	1	Commander Naval Surface Weapons Center Dahlgren, VA 22448
3	Commander US Army Research Office P.O. Box 12211 ATTN: Technical Director Engineering Division Metallurgy & Materials Division Research Triangle Park NC 27709	4	Commander Naval Surface Weapons Center ATTN: Code G-33, T.N. Tschirn Code N-43, J.J. Yagla L. Anderson G. Soo Hoo Dahlgren, VA 22448
1	Director US Army TRADOC Systems Analysis Activity ATTN: ATAA-SL (Tech Lib) White Sands Missile Range, NM 88002	3	Commander Naval Surface Weapons Center ATTN: Code E-31, R.C. Reed M.T. Walchak Code V-14, W.M. Hinckley Silver Spring, MD 20910
1	Commander Naval Air Systems Command Washington, DC 20360	1	Commander Naval Surface Weapons Center Silver Spring, MD 20910
1	Commander Naval Sea Systems Command Washington, DC 20362	1	Commander Naval Weapons Center China Lake, CA 93555
1	Commander Naval Sea Systems Command ATTN: SEA-03513, L. Pasiuk Washington, DC 20362	3	Commander Naval Weapons Center ATTN: J. O'Malley D. Potts R.G. Sewell China Lake, CA 93555
1	Commander Naval Air Development Center Johnsville Warminster, PA 18974	1	Commander Naval Research Laboratory Washington, DC 20375

DISTRIBUTION LIST

<u>No. of Copies</u>	<u>Organization</u>	<u>No. of Copies</u>	<u>Organization</u>
1	Superintendent Naval Postgraduate School ATTN: Dir of Lib Monterey, CA 93940	2	ARES Inc. ATTN: Duane Summers Phil Conners Port Clinton, OH 43452
1	Commander Naval Ordnance Station Indian Head, MD 20640	1	General Electric Company ATTN: Armament Systems Dept. David A. Graham Lakeside Avenue Burlington, VT 05402
2	Commander Naval Ordnance Station ATTN: Code 5034, Ch, Irish Jr. T.C. Smith Indian Head, MD 20640		<u>Aberdeen Proving Ground</u> Dir, USAMSAA ATTN: DRXSY-D DRXSY-G, E. Christman DRXSY-OSD, H. Burke DRXSY-G, R.C. Conroy DRXSY-LM, J.C.C. Fine DRXSY-MP, H. Cohen
1	AFATL Eglin AFB, FL 32542		Dir, USAHEL ATTN: A.H. Eckles, III
3	AFATL (DLJM, W. Dittrich; DLD, D. Davis; DLDL) Eglin AFB, FL 32542		Cdr, USATECOM ATTN: DRSTE-TO-F
2	AFWL/SUL Kirtland AFB, NM 87115		Dir, USACSL, Bldg. E3516, EA ATTN: DRDAR-CLB-PA DRDAR-CL DRDAR-CLB DRDAR-CLD DRDAR-CLY DRDAR-CLN
1	Director Lawrence Livermore Laboratory P. O. Box 808 Livermore, CA 94550		Cdr, USAAPG ATTN: STEAP-MT-G, James Fasig Kenneth Balliet
1	Director Los Alamos Scientific Lab P. O. Box 1663 Los Alamos, NM 87544		
2	Director National Aeronautics and Space Administration Langley Research Center Langley Station Hampton, VA 23365		
1	Aircraft Armaments Inc. ATTN: John Hebert York Road 7 Industry Lane Cockeysville, MD 21030		

USER EVALUATION OF REPORT

Please take a few minutes to answer the questions below; tear out this sheet, fold as indicated, staple or tape closed, and place in the mail. Your comments will provide us with information for improving future reports.

1. BRL Report Number _____

2. Does this report satisfy a need? (Comment on purpose, related project, or other area of interest for which report will be used.)

3. How, specifically, is the report being used? (Information source, design data or procedure, management procedure, source of ideas, etc.) _____

4. Has the information in this report led to any quantitative savings as far as man-hours/contract dollars saved, operating costs avoided, efficiencies achieved, etc.? If so, please elaborate.

5. General Comments (Indicate what you think should be changed to make this report and future reports of this type more responsive to your needs, more usable, improve readability, etc.) _____

6. If you would like to be contacted by the personnel who prepared this report to raise specific questions or discuss the topic, please fill in the following information.

Name: _____

Telephone Number: _____

Organization Address: _____

FOLD HERE

Director
JS Army Ballistic Research Laboratory
Aberdeen Proving Ground, MD 21005



NO POSTAGE
NECESSARY
IF MAILED
IN THE
UNITED STATES

OFFICIAL BUSINESS
PENALTY FOR PRIVATE USE. \$300

BUSINESS REPLY MAIL
FIRST CLASS PERMIT NO 12062 WASHINGTON, DC
POSTAGE WILL BE PAID BY DEPARTMENT OF THE ARMY



Director
US Army Ballistic Research Laboratory
ATTN: DRDAR-TSB -S
Aberdeen Proving Ground, MD 21005

FOLD HERE

FILM

2-8