

MICROCOPY RESOLUTION TEST CHART
NATIONAL BUREAU OF STANDARDS-1963-A

2

FTD-ID(RS)T-1275-82

AD A122784

FOREIGN TECHNOLOGY DIVISION



DIGITAL MULTIPLEXING SYSTEM OF THE TCC 120 TYPE

by

Bogdan Czajka and Witold Wienskowski

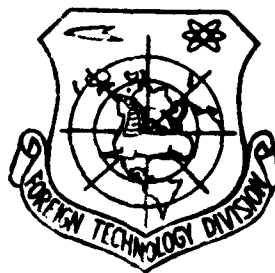

DTIC
SELECTED
DEC 29 1982
S E D

Approved for public release;
distribution unlimited.

FILE COPY



82 12 28 1982

GRAPHICS DISCLAIMER

All figures, graphics, tables, equations, etc. merged into this translation were extracted from the best quality copy available.

EDITED TRANSLATION

FTD-ID(RS)T-1275-82

23 November 1982

MICROFICHE NR: FTD-82-C-001499

DIGITAL MULTIPLEXING SYSTEM OF THE TCC 120 TYPE

By: Bogdan Czajka and Witold Wienskowski

English pages: 20

Source: Przegląd Telekomunikacyjny, Vol. 52, Nr. 9,
1979, pp. 260-265

Country of origin: Poland
Translated by: LEO KANNER ASSOCIATES
F33657-81-D-0264

Requester: RCA
Approved for public release; distribution unlimited

Accession For	
DTIC	<input checked="" type="checkbox"/>
NSA&I	<input type="checkbox"/>
Other	<input type="checkbox"/>
Justification	
By _____	
Distribution/	
Availability Codes	
Dist	Avail and/or Special
A	



<p>THIS TRANSLATION IS A RENDITION OF THE ORIGINAL FOREIGN TEXT WITHOUT ANY ANALYTICAL OR EDITORIAL COMMENT. STATEMENTS OR THEORIES ADVOCATED OR IMPLIED ARE THOSE OF THE SOURCE AND DO NOT NECESSARILY REFLECT THE POSITION OR OPINION OF THE FOREIGN TECHNOLOGY DIVISION.</p>	<p>PREPARED BY: TRANSLATION DIVISION FOREIGN TECHNOLOGY DIVISION WP-AFB, OHIO.</p>
---	---

Bogdan Czajka and Witold Wienskowski

Features of the TCC 120 Equipment

In accordance with worldwide tendencies in the area of telecommunications transmission, the corresponding decision has been made in Poland leading to the goal of introducing multichannel telephone systems into the country's communications network using time division channels. The implications of this problem area have increased significantly in connection with startup of production and the introduction into use of electronic telephone centrals of the E-10 system, which has created, additionally, the need for digital telecommunications transmission systems. For the purposes of meeting these needs, 30-channel telephone equipment of the TCC 30 type has been developed and introduced into production and use, using pulse-code modulation.

The next step in the development of digital systems in Poland involves second order digital multiplexing equipment of the TCC 120 type. It has been developed by the Institute of Communications and the TELKOM-TELETRA Plants. This equipment serves for multiplexing for time-simultaneous digital signals of 2048 kbit/s in the transmission section during a sequence of secondary signals of 8448 kbit/s, as well as the formation of four component signals with the above-named speeds in the reception portion.

The TCC 120 system is specified for transmission of digital signals in intra-regional networks, intra-provincial networks, as well as in district networks at distances from several tens of kilometers to several hundred kilometers. The line routing equipment of the system is adapted for working with special cable with symmetrical channels and a single-core design of the ALTKDNXpx type, planned for the transmission of 2 and 8 Mbit/s digital signals.

The following basic equipment is included in the TCC 120 equipment:

- multichannel terminals (KWZ),
- terminal line route equipment (UKL),
- straight-through repeater stations (SR).

In addition, the system includes auxiliary measuring and checking equipment and facilitates the operational use, including the following items:

- the PL-TCC 120 line tester,
- the UKC-TCC 120 equipment for cyclical control.

The TCC 120 multichannel terminal can work together with the following equipment on the input and output sides of primary groups:

- 30-channel telephone terminal with code-pulse modulation, e.g., of the TCK 30 type,
- 30-channel line route equipment (cable or radio line), in accordance with CCITT provisions, e.g., the TCK 30 system,
- TN 60 intermediate multichannel station (2 x TCK 30; in this case, two input and output multichannel stations are used),
- data transmission equipment with the capacity of 2048 kbit/s.

On the input and output sides of a secondary group, the TCC 120 can work with the following:

- with line route terminal equipment having a capacity of 8448 kbit/s (cable line or radio line),
- with a multichannel terminal of a third order digital multiplexing system.

The TCC 120 multichannel terminal works on the principle of positive bit stop transmission in accordance with recommendation G 742 of the CCITT. Frame structure of this system is shown in Fig. 1. A frame, consisting of 848 bits, is divided into four sections, each of which comprises 212 bits. Eight hundred twenty-four frame bits are specified for the transmission of primary group information. The remaining 24

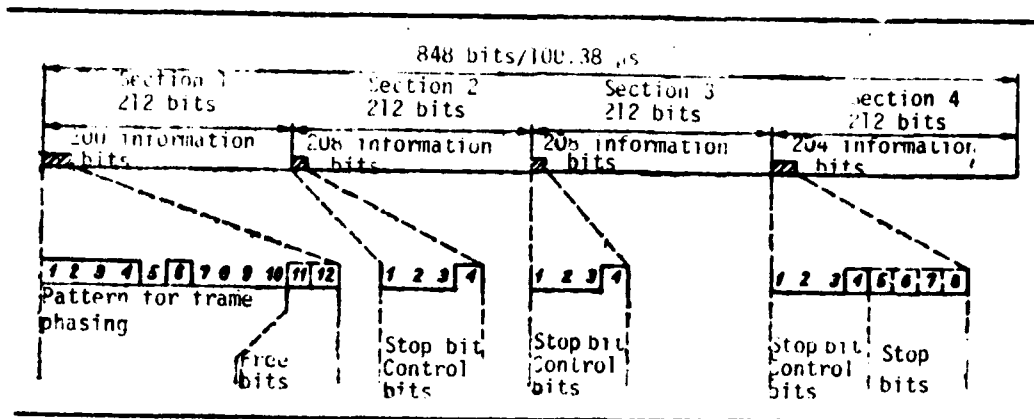

Fig. 1. TCC 120 system frame structure (logical values of "1" for stop bit checking of No. 4 is shown being executed in channel 4).

bits are used for frame phasing, controlling the execution process, sending alarm signals, etc.

The stop bit control bits in sections 2, 3 and 4 are assigned to individual channels in the multichannel terminal. Bits in positions 1-4 are used for execution in the corresponding return channel. If primary groups are executed in the signal for a given channel, the signal 111 is then sent by means of the stop control bits. When execution is lacking, the signal 000 is sent. A decision is taken in the receiving equipment with regard to execution or lack of execution on the basis of the control bits. Bits in the 11 position in section 1 serve for transmitting an alarm signal to an adjacent coworking station (in the alarm state, this bit takes the value of "1").

The TCC 120 route line carrier works in a single cable system using two pairs of conductors placed in different shielded cable bundles. The UKL-TCC 120 terminal line equipment includes terminal regenerators (transmitting and receiving), as well as a remote feeder cable for the straight-through regenerators. The SR-TCC 120 straight through regenerator stations are placed along the cable line every 4 km with a tolerance of ± 200 m, with a maximum distance between line terminal equipment (including equipment with the remote feeder cable) of about 150 km. The UKL receiving and transmitting regenerators can be hooked up end-to-end, forming straight through equipment that may be attended

and serviced and having remote feeder cables, this makes it possible to lengthen the carrier line up to several hundred km.

UKL-TCK 30 terminal line auxiliary equipment, with remote feeder cables, stacked in the UL-TCK 30 rack, is provided for the introduction of primary groups into the TCC 120 multichannel terminals by means of the TCK 30 carrier line. A block diagram of the TCC 120 system is shown in Fig. 2.

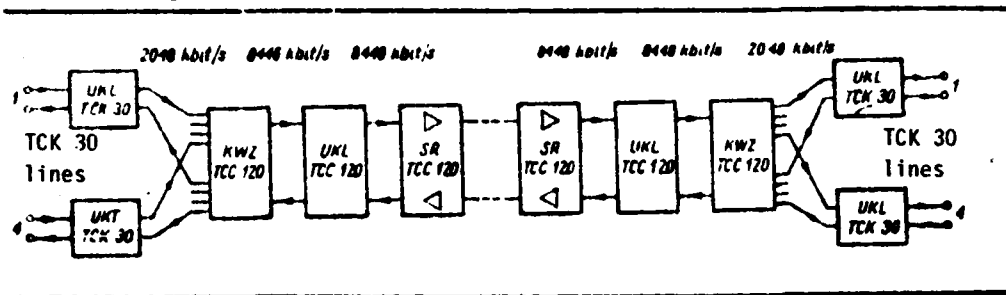

Fig. 2. Block diagram for the TCC 120 system (referred to in text).

Equipment Design and Construction

The terminal equipment for the TCC 120 system is constructed in the form of cubical racks containing, depending on their designations, different component parts. These racks have typical overall dimensions for telecommunications transmission equipment giving access to the assembly groups from only one side: width, 600 mm; depth, 225 mm, height, 2600 mm (the larger racks) or 2000 mm (the small racks). The individual assembly unit components of the equipment are manufactured in the form of packs or blocks with intermediate connections and grouped together in one or three shelf panel units. The internal dimensions for these cubicles, or shelves, have been normalized, and they are: height, 140 mm, width, 460 mm, depth, 150 mm. One multichannel terminal or one piece of terminal line equipment with remote and auxiliary feeder cables are placed in a single shelf or cubicle.

The panel unit cabling is carried out by means of wrapping, and cabling between the panel units as well as between the station units

is carried out by means of multi-conductor cable manufactured with appropriate intermediate connections. All the cables are joined together in a shielded recess on the left-hand side of the rack. The front side of the rack is unshielded, and facing panels placed into the assembly unit racks form a unified front wall.

The design of the racks and the panels makes it possible to put together different variants of the assembly, assuring the economical and optimal outfitting of individual telecommunications transmissions stations with the required equipment.

In accordance with fixed TCC 120 equipment assemblies, the following basic types of racks can be distinguished:

1. the rack for the UM-TCC 120 (small) terminal equipment, into which are placed four KWZ multichannel terminals, as well as four sets of UKL terminal line equipment,
2. the rack for the UK-TCC 120 (large) terminal equipment, into which are placed eight KWZ multichannel terminals, as well as the UKC equipment for cyclical control,
3. the rack for the UL-TCC 120 terminal line equipment, into which are placed 12 sets of UKL-TCC 120 terminal line equipment, as well as the PL-TCC 120 line tester,
4. the rack for the UL-TCK 30 (small) terminal line equipment, into which are placed eight sets of UKL-TCK 30 terminal line equipment, as well as the PL-TCK 30 line tester.

Each rack is outfitted with an additional cubicle for monitoring equipment and communications service equipment, in which appropriate trunk route communications equipment and branch communications equipment, as well as signalling alarm equipment, are placed.

The SR-TCC 120 transit, straight through regenerator stations include six or twelve straight through regenerators, as well as a unit

for locating breakdowns, which makes it possible to carry out remote monitoring of active regenerators or the detection of damaged regenerators. Both the regenerator stations, as well as the straight through regenerators installed in them, are constructed hermetically. The accumulators for the stations are manufactured in the form of cabinets made from light metal in the form of a cube with dimensions 290 x 280 x 510 mm (for six regenerators), or 290 x 280 x 1020 mm (for 12 regenerators). The SR-TCC 120 accumulators are adapted for installation in underground cable channels. The individual types of racks and regenerator stations are shown in Fig. 3.

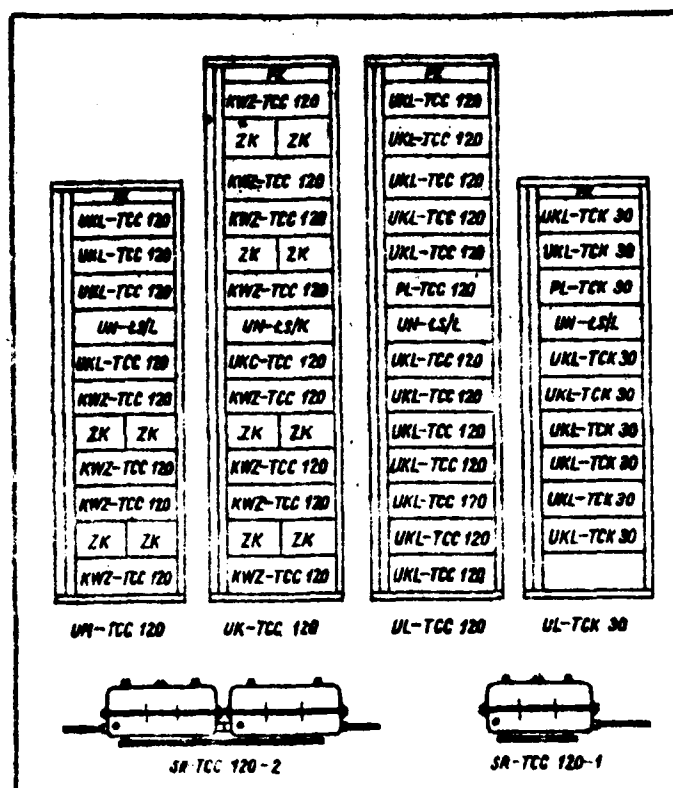

Fig. 3. Types of racks and regenerator stations in the TCC 120 system.

Technical Data for the TCC 120 ([1], [2])

- number of primary channels, 4;
- binary traffic capacity of 2.048 kbit/s primary signals, $\pm 50 \times 10^{-6}$;

- binary flow capacity for a secondary signal of 8440 kbit/s, $\pm 30 \times 10^{-6}$;
- positive pulse execution according to G 742 CCITT.

Contact Point Parameters for the Multichannel Terminal

2 Mbit/s contact points:

- type of code, HDB3;
- load impedance, 120 Ω , symmetrical;
- signal pulse for the output signal, 3V \pm 10%;
- nominal pulse width, 244 ns.

8 Mbit/s contact points:

- type of code, HDB3;
- load impedance, 75 Ω , nonsymmetrical;
- pulse amplitude for output signal, 2.37 V \pm 10%;
- nominal pulse width, 59 ns.

The output pulse shapes are in accordance with G 703 recommendations from CCITT. The shape and amplitudes of the input signals of 2 Mbit/s and 8 Mbit/s are damped and deformed through the line with an attenuation of 0-6 dB at frequencies respectively of 1024 kHz and 4224 kHz.

Parameters of the Line System Equipment

Outputs from the 2 Mbit/s primary channels:

- type of code, HDB3;
- load impedance, 135 Ω , symmetrical;
- pulse amplitude for the output signal, 3 V \pm 10%.

Output of the 8 Mbit/s secondary group:

- code type, HDB3;
- load impedance, 160 Ω , symmetrical;
- pulse amplitude for output signal, 3 V \pm 10%.

Regeneration branches:

- length of branches, 4 km \pm 200 m;
- nominal attenuation at a frequency of 4224 kHz, 56 dB;
- maximum attenuation for frequency of 4224 kHz, 65 kB.

Equipment Power Feed

- accumulator batteries with voltages of 60 V \pm 10% or 50 V \pm 10%, in manufactured blocks of 24 V \pm 25%-10%;
- power consumption by the terminal, 40 VA;
- power consumption by the UKL together with the remote power feed line cable, 80 VA;
- remote power feed current, 90 mA;
- maximum remote power feed voltage, \pm 240 V.

Climatic Parameters for the Equipment

- temperature range for terminal equipment, +5°C-+40°C;
- maximum relative humidity, 85% at a temperature of 30°C;
- working temperature range for regenerator stations, -20°C-+35°C;
- relative ambient humidity for the station, up to 98%.

Principle of Operation

KWZ-TCC 120 Multichannel Terminal

The following assembly units make up the KWZ-TCC 120 multichannel terminal:

4 2 Mbit/s P 601 code transceivers, 4 P 611 input memory assemblies, 1 8 Mbit/s P 621 transmitter, 1 8 Mbit/s P 631 code transceiver, 1 8 Mbit/s P 641 receiver, 4 P 651 output memory assembly units, 1 P 661 control set for the multichannel terminal, and 1 P 671 cyclical control assembly.

In addition, each multichannel terminal has its own individual power feed cable made up of a Z 601 local feed cable and the Z 621 auxiliary feed cable. A block diagram of the KWZ multichannel terminal is shown in Fig. 4.

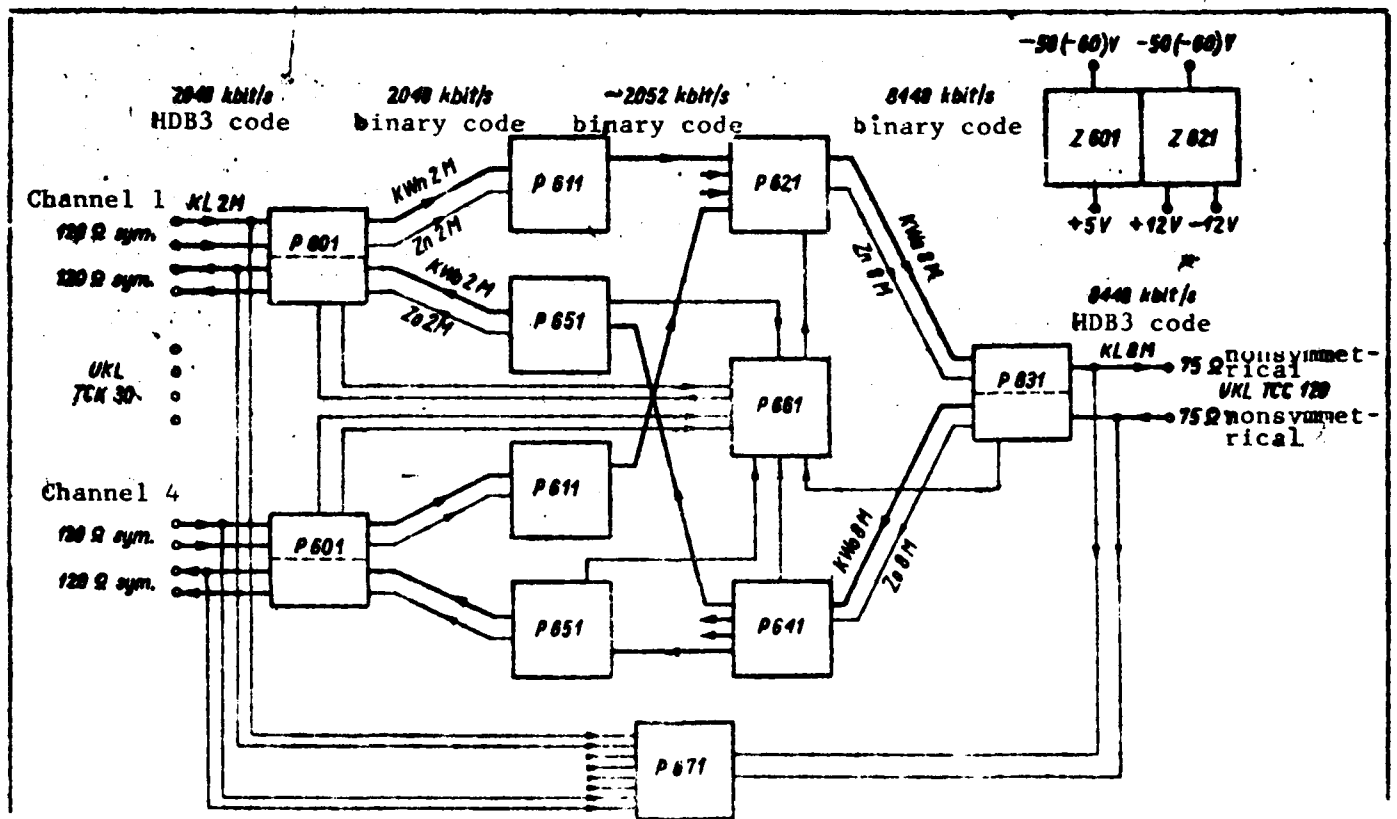

Fig. 4. Block diagram of the KWZ-TCC 120 multichannel terminal.

On the 2 Mbit/s primary group side, the multichannel terminal includes four channel group sets, each of which services one group. Each channel set includes the following: a P 601 code transceiver, a P 611 input memory, and P 651 output memory. The 2 Mbit/s digital signal

arriving from off the line and which has undergone attenuation from the communications cable (maximum 6 dB at a frequency of 1024 kHz), is subjected to compensating regeneration and is decoded from the HDB3 line code into binary code. At the same time, the beat signal for a given group with a frequency of 2048 kHz is taken out of the line code.

Both signals, the binary code and the beat signal, are fed to the input memory. There the process of adding or synchronizing the signal with the frequency of the 8448 kHz secondary group is carried out. The signal is sent to the 8 Mbit/s (P 621) transmitter from the input memory; here the signal is digitally modulated and the four primary channel signals are joined together on the principle of bit quantizing. At the same time, additional bits containing the frame phasing signal, as well as free bits, are introduced into the cumulative signal. In addition, a beat signal of 8448 kHz is generated in the P 621 equipment, as well as clock oscillator processes serving for the control of the input memory systems. The cumulative binary signal as well as the clock oscillator signal of 8448 kHz is sent successively then to the P 631 code transceiver, where the signal is changed from binary code to the HDB3 line code with a binary flow capacity of 8448 kbit/s, and the signal is then transmitted in this form to the line equipment.

The opposite processes are carried out on the receiving end. The digital signal with a flow capacity of 8448 kbit/s received off the line is subjected to compensating regeneration of the attenuation (up to 6 dB at a frequency of 4224 kHz) resulting from the communications cable in the P 631 code receiver, after which it is decoded from the HDB3 line code into binary code. At the same time, the 8448 kHz beat signal is reproduced.

Both signals are sent subsequently to the P 641 receiver, where the process of frame phasing is carried out, as well as breaking down the cumulative group signal into four digital sequences corresponding to the individual primary groups of 2048 kbit/s. In addition, the clock

oscillator processes which serve for controlling the output memory are carried out in the P 641 equipment. The 2048 kbit/s signals that have been separated move from the receiver into the P 651 output memory equipment, where the stop bit controls are eliminated and the initial form of the given binary signal is restored, as well as the original form of the 2048 kHz beat signal. Both signals are sent from the output memory assembly to the transmitting side of the P 601 code transceiver. In the code transceiver the signal is changed from binary code to the HDB3 line code, and the signal is sent into the line in this form.

Multichannel terminal operation is monitored by the control systems and the alarm systems grouped in the P 661 control assembly for the multichannel terminal. The following data are subject to control: exceeding the phase tolerance of the primary signals, the presence of incoming and outgoing signals, the frame phasing states and power feed, the presence of a signal giving information on alarms (SIA), and the state of the adjacent coworking multichannel terminal (through special alarm bits). In cases where irregularities are detected, a visual display of the type of malfunctioning is generated, and appropriate alarm signals are set off. Exceeding the phase tolerance of primary signals, a drop in input and output signals, a loss of compatibility in the frame of a secondary group, as well as detection of an SIA 8 Mbit/s signal, sets off the transmission of 2 Mbit/s alarm information signals from the P 661 assembly to the coworking primary group equipment.

Multichannel terminal operation can be additionally controlled continuously by using the cyclical control equipment UKC-TCC 120. The cyclical control equipment, which is placed in the UK-TCC 120 rack, or else is built itself in the form of a rack (the portable variant), is hooked into the 2 Mbit/s input and the 8 Mbit/s output, or else into the 8 Mbit/s input and the 2 Mbit/s output. This carries out comparison of signals at both ends of the multichannel terminal. The 2 mbit/s channel that is malfunctioning, as well as the number of the multichannel

terminal in which this channel is located, is indicated by means of a light device using light diodes located on the facing plate of the equipment.

The UKC equipment is hooked into the multichannel terminal across the P 671 cyclical control unit, which carries out cyclical commutation of all the channels making up a given multichannel terminal. Power feed for the multichannel terminal is carried out by means of the local Z 601 set and the Z 621 auxiliary set. A local feeder cable includes a main direct current converter, as well as a stabilized voltage power source of +5 V. The auxiliary feeder cable includes a startup converter, as well as a stabilized power voltage source with voltages of -12 V and +12 V.

The UKL-TCC 120 Terminal Line Equipment

The UKL-TCC 120 terminal line equipment is a component of the digital line equipment with a binary flow capacity of 8448 kbit/s. The UKL-TCC 120 equipment is designated for working together with KWZ-TCC 120 secondary modulating digital multichannel terminals, or else together with other digital information sources with binary flow capacities of 8448 kbit/s, in a double-channel nonsymmetrical system with overall characteristic impedance of 75 Ω , as well as for working together with other pieces of UKL-TCC 120 terminal line equipment. Connecting may be done directly, or - by means of a special symmetrical cable with multi-wire design - by means of unattended SR-TCC 120 regenerator stations in a double channel symmetrical system with an impedance of 160 Ω . The UKL-TCC 120 terminal line equipment carries out the following tasks:

- bidirectional digital signal transmission,
- regeneration and matching the equipment for contact point parameters with characteristic impedances of 75 Ω and 160 Ω ,
- remote straight through regenerator power feed,
- controlling for correct working of the digital line,
- safeguarding the anti-lightning and overload equipment.

The following items make up the UKL-TCC 120 terminal line equipment: the L 601 transmitting regenerator set, the L 611 receiving regenerator set, two L 621 line protection and matching assemblies, an L 631 error rate control set, an L 641 line control set, an L 801 remote power feed filter set, the Z 611 remote feeder cable, and the Z 631 local feeder cable.

A block diagram of the UKL-TCC 120 terminal line equipment is shown in Fig. 5. In it, the transmission direction and the reception direction may be distinguished, as well as the auxiliary equipment. The transmission direction includes the L 601 transmission regenerator, as well as the L 621 line protection and matching set. The L 601 transmission regenerator carries out the following functions:

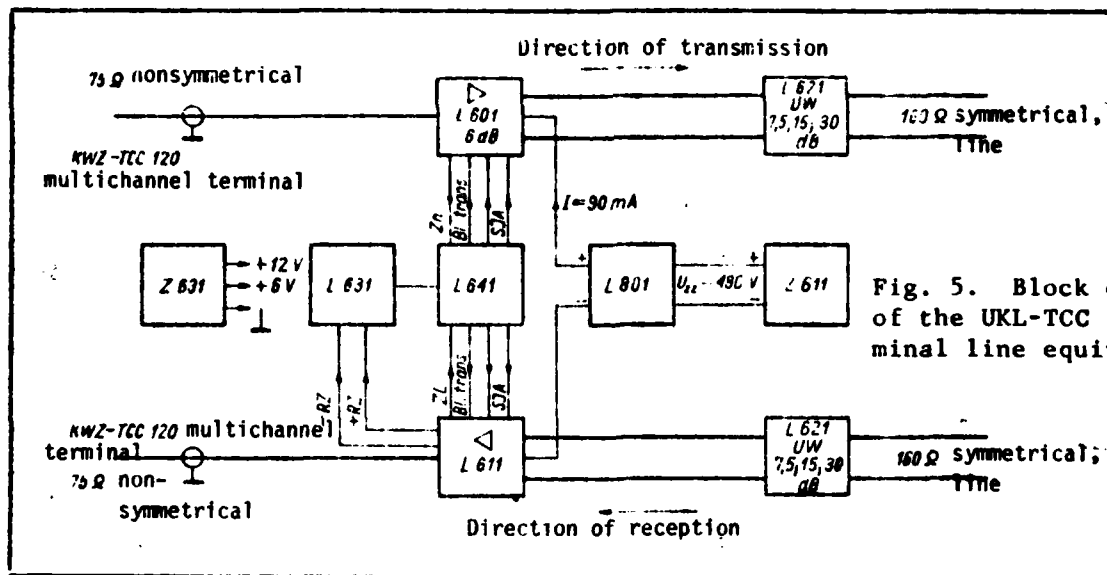

Fig. 5. Block diagram of the UKL-TCC 120 terminal line equipment.

- amplifies and regenerates the digital signal sent into the UKL-TCC 120 terminal line equipment from the station side by means of coaxial cable with damping from 0 to 6 dB for a frequency of 4224 kHz and wave impedance of 75 Ω ;

- makes it possible to introduce a special characteristic SIA signal of the form "111..." and binary rate flow of $8448 \pm 30 \cdot 10^{-6}$ kbit/s

into the channel in the case when there is a signal drop originating from the station side (e.g., from a KWZ-TCC 120 secondary modulation digital multichannel terminal),

- assigns a clock oscillator transmitting signal, which controls the L 641 line control set.

The L 621 line protection and matching equipment carries out the following functions in its turn:

- protects the UKL-TCC 120 equipment against direct current as a result of atmospheric loading or from cable contact with power line conductors,

- matches line attenuation by means of three serially connected symmetrical line systems with increased attenuations of 7.5 dB, 15 dB, and 30 dB, and by means of a primary regenerator circuit with nominal impedance of 56 ± 7 dB at a frequency of 4224 kHz and a temperature of $+10^{\circ}\text{C}$.

The temperature changes in the cable should be taken account of; for a temperature of $+30^{\circ}\text{C}$, attenuation increases by +2.5 dB, whereas at a temperature of 0°C , attenuation is reduced by 1.2 dB.

The receiving direction includes, just as the transmitting direction, an L 621 line protection and matching set, as well as the L 611 receiving regenerator. The L 611 receiving regenerator regenerates the digital signal brought into the UKL-TCC 120 terminal line equipment from the line side, i.e., from the side of the special symmetrical cable with multi-wire design; the L 621 receiving regenerator has an impedance of 160 Ω and a primary regenerator circuit attenuation from 0 to 56 ± 7 dB at a frequency of 4224 kHz.

The receiving regenerator is outfitted, in addition, with a logic gate system making it possible to introduce a characteristic SIA signal

in case of a breakdown in the digital signal coming from the line side (off the cable). The auxiliary assemblies in the terminal line equipment have the following functions:

- continuous control of the working of the UKL-TCC 120,
- to signal in case of detected irregularities in equipment function by means of urgent and non-urgent alarms,
- to provide power feed for the UKL-TCC 120 equipment,
- to provide remote power feed for the L 701 straight through re-generators.

The following equipment is included in the auxiliary equipment: an L 631 control complex for error rate, the L 641 line control complex, the L 801 remote feeder cable filter, the Z 611 remote feeder cable, and the Z 631 local feeder cable.

The L 631 error rate control complex has systems for detecting excesses in error rate of 10^{-5} or 10^{-2} . Exceeding an error rate of 10^{-5} in the signal coming from the line causes an optical indicator to be switched on that shows the type of irregularity, as well as the sending of a signal for the purpose of actuating the non-urgent comprehensive alarm. On the other hand, exceeding an error rate of 10^{-2} in the signal incoming from the line causes the following: switching on the optical indicator, the initiation of a characteristic SIA signal to the multichannel terminal in place of the signal incoming off the line, as well as sending a signal for the purpose of actuating the comprehensive urgent alarm.

The L 641 line control complex monitors the functioning of the UKL-TCC 120. Its control systems for the transmitter and receiver clock oscillator mechanism signal a breakdown in the signal incoming from the multichannel terminal, as well as off the line, in the form of an urgent alarm. Entering into the makeup of this complex are also

the following: an SIA signal generator for alarms, systems for delaying transmission of this signal along the transmission direction for the reception direction, as well as delay systems for initiation and breakoff of an alarm.

The remote feeder cable filter, by means of which remote power feed is provided for the transmission and receiving transformer regenerators, as well as to the phantom circuits for feeding power to the straight through regenerators, has the purpose of increasing the attenuation of signal crosstalk along the transmitting direction for reception by the remote feeder cable circuits. The Z 611 remote feeder cable and the Z 631 local feeder cable form the power feedblock for the UKL-TCC 120, which is outfitted with a startup converter as well as with a current stabilization system and voltage stabilizer systems. In addition, the feeder cables are equipped with alarm signalling systems which detect the following:

- a drop in remote power feed current,
- the overestimation of remote power feed current,
- breakdown in remote power feed current,
- leakage arising in the remote feeder cable jacket,
- a drop of +5 V in the local feeder cable.

The SR-TCC 120 Regenerator Station

The type SR-TCC 120 regenerator station is an unattended telecommunications transmission station that is a part of the line route for the TCC 120 digital system. In its single accumulator battery version, it makes it possible to create a maximum number of six digital channels with a bit rate of 8448 kbit/s. The regenerator station is equipped with the L 701 straight through regenerator and the L 711 locating complex.

The L 701 straight through regenerator (Photo 1) receives an attenuated, deformed and noisy digital signal at input, which is transmitted

across a section of about 4 km in length from another straight through regenerator (nominal attenuation of this section is 56 dB). The signal

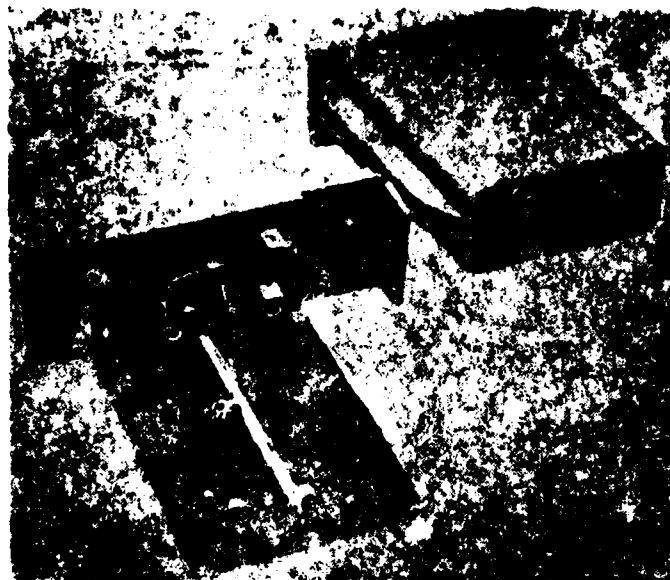

Photo 1. Straight through regenerator for the TCC 120 system (opened).

is amplified and "cleaned" in a preamplifier system. The straight through regenerator is equipped with an automatic line equalizer, which boosts cable channel attenuation to maximum attenuation. The signal amplified in the preamplifier meets the signal reconstituted by the clock oscillator; this signal forms rectangular pulses with a time duration of 59 ns in the appropriate system.

Straight through regenerators are remotely powered from the UKL-TCC 120 terminal line equipment with a steady intensity current of 90 mA and a voltage varying depending on the length of the line, maximally up to 480 V (+240 V in relation to ground). The voltage breakdown in a Zener diode is taken as the feed voltage for the straight through regenerator systems. Voltage breakdown on a bidirectional regenerator is 11 V.

The L 711 location complex works together, on the one hand, with straight through regenerators placed in a given regenerator station,

and on the other hand, it works together with a line tester in locating a broken down straight through regenerator.

Two modules are placed in the L 711 location complex. One includes the location complex proper, and the other includes two location signal repeaters. The location complex proper is made up of the following: a small frequency signal receiver system, a logic system, an executive system, and a low frequency signal transmitter. The location signal repeaters regenerate a location signal that has been transmitted, and they are made up only of receiver and transmitter systems. The location signal repeaters are used in the case when channels are switched in several directions and is necessary to perform additional pairs of remote location. Remote location pairs from the disconnection point of the channels (arriving at the station through the signal repeaters) are connected up to the locator complex proper, making it possible to remotely locate an uncoupled digital line.

The PL-TCC 120 Line Tester

The PL-TCC 120 line tester is designated for testing regenerated transmission quality in a digital line, as well as for the remote location of a damaged or malfunctioning L 701 straight through regenerator.

L 711 locator complexes are installed in regenerator stations for working together with the PL-TCC 120 line tester. They control the loop closing systems in the L 701 straight through regenerators. Remote monitoring and quality testing of a regenerator depend on the direct measurement of error rates in relayed digital transmissions in the loop of a digital line formed in the regenerator being remotely monitored and tested. with the regenerator being used for transmission from the direction A→B to the direction B→A. The checking method is based on the principle of comparing the digital signal being tested, according to its transit time through the line, with a standard signal generated in the receiver. The indicator for correct line functioning is the

number of errors indicated on a digital display. The PL-TCC 120 line tester makes it possible to measure error rates in four ranges: $nx10^{-7}$, $nx10^{-8}$, $nx10^{-9}$, and $nx10^{-10}$.

The appropriate number of the regenerator station which we wish to monitor can be selected from the PL-TCC 120 line tester (i.e., the number of the regenerator station at which we wish to close the loop for transmitting from the direction A→B to the direction B→A). The number of the regenerator station being checked is displayed by means of a digital indicator.

For the purposes of additional monitoring and testing of the place where the transmission loop is closed, the line tester checks and reads out the delay time for pulse passage through the line being studied. This method for determining transmission quality is based on the examination of error rates with variations in the binary bit rate of the digital signal that is being tested as it is emitted from the line tester in a pseudo-random code with a sequence length of 32,767 bits. The variation in the binary bit rate is displayed on a digital display. The following complexes are included in the PL-TCC 120 line tester (Photo 2): L 721 generator complex, L 731 code transmission complex, L 741 code receiver complex, L 751 comparator complex, L 761 station meter complex, L 771 time base complex, P 632 code transceiver, Z 601 local feeder cable, and Z 621 auxiliary feeder cable.



Photo 2. All-purpose line tester for TCK 30 and TCC 120 systems (portable version) used as remote control and locating line equipment in both systems.

LITERATURE

1. Wymagania techniczno-eksploatacyjne na krotnice TCC 120 systemu cyfrowego 8 Mbit/s, "Technical and Use Specifications for the TCC 120 8 Mbit/s Multichannel Terminal Digital System," IL, Warsaw, 1976 (comprehensive version).
2. Wymagania techniczno-eksploatacyjne na urzadzenia traktu liniowego 8448 kbit/s z kablem symetrycznym specjalnym, "Technical and Use Specifications for the 8448 kbit/s Line Equipment with Special Symmetrical Cable," IL, Warsaw, 1976 (comprehensive version).

END

FILMED

2-83

DTIC