

AD-A122 878



CREW ROLES IN MILITARY SPACE OPERATIONS(U) RAND CORP  
SANTA MONICA CA B LEINWEBER MAR 82 RAND/P-6745

1/1

UNCLASSIFIED

F/G 5/9

NL

													
					END DATE FILMED 6-15-83 DTIC								

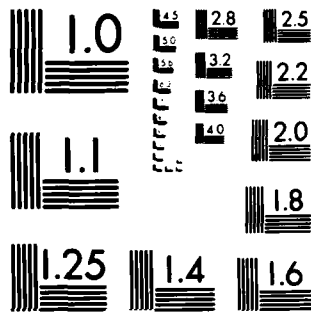

MICROCOPY RESOLUTION TEST CHART  
NATIONAL BUREAU OF STANDARDS-1963-A

2

AD A 1 22878

CREW ROLES IN MILITARY SPACE OPERATIONS

David Leinweber

DTIC  
SELECTED  
JAN 3 1983  
H D

March 1982

DTIC FILE COPY

DISTRIBUTION STATEMENT  
Approved for public release;  
Distribution Unlimited

P-6745

82 12 30 009

### The Rand Paper Series

Papers are issued by The Rand Corporation as a service to its professional staff. Their purpose is to facilitate the exchange of ideas among those who share the author's research interests; Papers are not reports prepared in fulfillment of Rand's contracts or grants. Views expressed in a Paper are the author's own, and are not necessarily shared by Rand or its research sponsors.

The Rand Corporation  
Santa Monica, California 90406

✓ I. INTRODUCTION

*here*  
We are now in the midst of a wide ranging debate on the role of the military in space. This issue has begun to attract substantial attention not only in the defense community, but from Congress, the executive branch, and the public as well.

In simple terms, the debate centers on the question of the degree of involvement of space systems in our future military operations. The military uses of space to date, as described in Refs. 1 through 3, have been largely in support of terrestrial military functions, communications, navigation, reconnaissance and surveillance. The systems have been passive and without capability of initiating hostile actions. There are those both in and out of the military establishment who believe (perhaps for different reasons) that no further expansion in the military use of space beyond the current support missions is called for. Some take this position out of a general opposition to the "militarization" of space, others feel that space systems are far too vulnerable to be relied on for important military purposes.

Another group would contend that, in keeping with technological changes, it is both necessary and prudent to expand the military capacity for operations in space by taking on new missions and expanding existing roles. This increase in capacity might include space defense systems to protect U.S. space assets and counter hostile actions. In this situation, space systems would still be a supporting, rather than a central, element in the nation's military posture. It has become apparent from Soviet activities that, at minimum, the USSR has incorporated these notions in its policy for military space activity.

Other policies proposed for the military use of space are more aggressive.

Military space activities would be limited to earth orbit only in the early stages of a determined effort to expand the strategic role of space. As often cited in plans for civilian space colonization and industrialization, the earth-moon system contains two points of stable equilibrium (known as L-4 and L-5), which are natural locations for the economical conduct of large-scale military and civilian space activities. These points will be of critical importance if the United States and USSR develop the capability to conduct space operations beyond the confines of low and geostationary earth orbits.

A concerted effort to establish military superiority by control of the "high ground" in space would require substantial revision of the treaties now governing space activities. The national security consequences of today's decisions on the military role of space will affect international relations for years to come. They should be made in a reasoned and deliberate fashion, rather than by default or by haphazard attempts to apply both manned and unmanned space techniques in an uncoordinated way.

## II. ROLES OF CREWS

For any outcome of the military space debate, we will still face the question of the appropriate degree of involvement for crews in the development, support, and operation of military space systems. These questions arise whether these systems are unarmed observation and support platforms or powerful weapons.

Soviet attitudes on these matters are in some ways clearer than our own. The extended six-month Salyut missions would have been impossible without the repairs, both scheduled and unscheduled, made by the crews. During the life of the Salyut spacecraft, major modifications were made to the life support systems, communication systems, and other components, including the manual release of a large dish antenna that had not deployed successfully on its own.

Arguments can be made that the Soviets' more backward technology, particularly in areas of information processing, forces them to use crews in space, while American systems can rely on superior computing. In fact, the Soviet experiences as reported confirm what we have seen in our own program (e.g., the emergency repair of Skylab and the reconfiguration of Apollo 13), that the most illuminating episodes of crew utility in space have not been of the "the computer could have done it" variety. The rapid advance in American electronic technology will not eliminate useful roles for military crews in space.

The tasks best suited for crews are first those which can be conducted in relatively safe environments. They should be nonrepetitive and relatively complex, requiring degrees of physical dexterity,

perceptual acuity, learning ability, intuitive decisionmaking, attention to detail, and an ability to deal with a wide range of contingency applications requiring the use of mechanical or electrical procedures.

Some tasks are best left for machines: those which are repetitive or rigidly defined, such as beam fabrication; those in acutely hostile environments, e.g., those requiring long exposures to radiation or subject to hostile military action; those in very remote locations, such as translunar space; and those requiring only routine and predictable mechanical and electrical manipulations.

We do know that in some ways astronauts are at a disadvantage. Many assembly tasks, such as bolting together components, are far more tiring in space due to the lack of gravity and limited mobility of suited crew members. While on earth many physical forces are provided by the friction between our feet and the ground, in space much greater muscular effort must be expended, for instance, just to stand still and turn a screw driver. As seen in Fig. 1, mobility limits are restrictive but not prohibitive, and many designs for individual work modules to attach directly to a spacecraft and hold the crew member in place have been proposed. These would allow mechanical work to be performed with far greater efficiency.

For some tasks, any mechanical disadvantage is outweighed by the perceptual and cognitive abilities of human crew members to notice unexpected and subtle phenomena.

A dramatic illustration of this important aspect of manned space activity occurred when astronauts on board Skylab noticed unexpected eddy current phenomena in the sea currents below. Their findings are important both for the military application of minimization of submarine

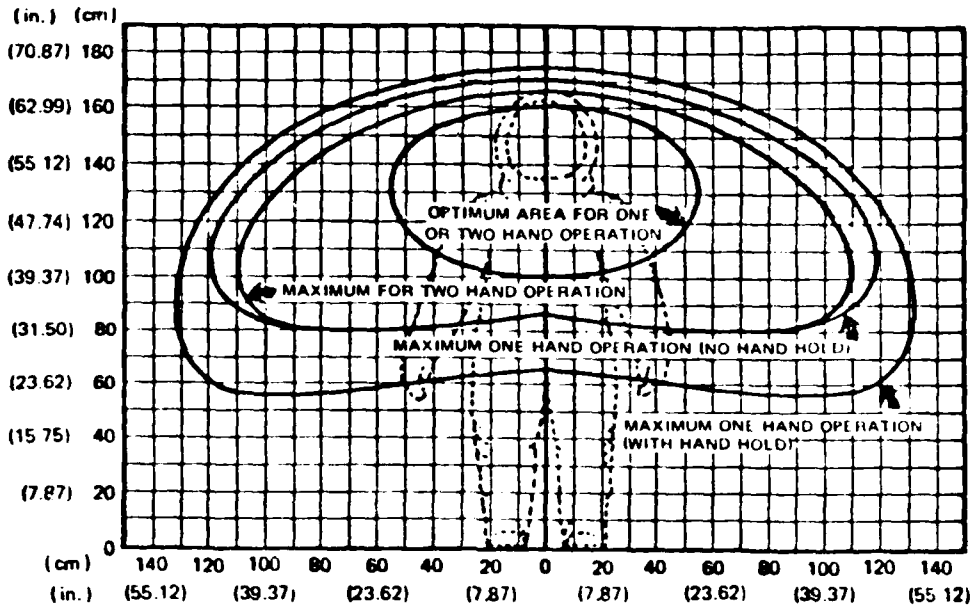

(a) Reach envelope, front view

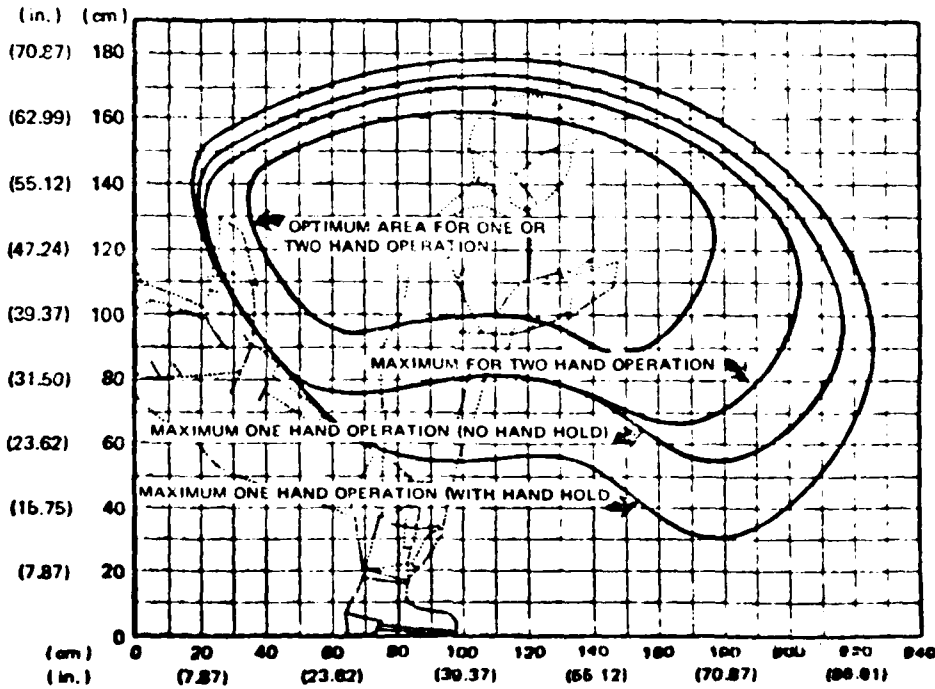

(b) Reach envelope, side view

SOURCE: Marshall Space Flight Center

Fig. 1 Limits of movement for an EVA suited crew member



Accession For  
 DTIC CARD  
 DTIC TAB  
 Unannounced  
 Justification  
 By free  
 Distribution/  
 Availability Codes  
 Dist Avail and/or  
 Special  
**A**

observables and the interpretation of sonar returns. The potential value of oceanographic data gathered by trained observers in developing an understanding of these eddy currents is sufficiently high that the Office of Naval Research has planned a seven-shuttle flight program to study the effects. The experiment, Project Nereus, is described in Ref. 4. Previous instances in which crews in space have made significant contributions to oceanographic science are documented in Refs. 5 and 6.

### III. TYPES OF CREW INVOLVEMENT

Space systems can be "manned" to different degrees. While we are used to thinking of a manned system as one in which the crew plays a central and continuing role, such as the Apollo missions or the shuttle program, there are in fact different degrees of crew involvement in systems that could properly be called manned.

Consider three categories of crew involvement. First, experimental research and development activities to develop new space systems. Second, the service, support, and maintenance of spacecraft by means of periodic crew visits of varying durations, and third, the active operation and participation by crews in ongoing manned space activity on continuously populated space platforms.

The Marshall Space Flight Center has characterized the interactions between crews and space systems which apply in all three contexts. These characterizations are seen in Table 1. They cover a wide range of activities, ranging from simple experimental setup to manned satellite and subsatellite operations.

Table 1

MAN/SYSTEM INTERACTION DEFINITIONS

<u>Man/System Interaction</u>	<u>Definition</u>
Experiment setup, direction	Crewman physically moves equipment/experiment from stowage to operation location, configures support systems (pre and post), and returns equipment to stowage after experiment completion.
Experiment start/stop	Crewman initiates and terminates experiment operations.
Monitoring at C&D panel	Monitoring experiment/payload status at display panel in orbiter (PSS) or Spacelab module; minimal crew activity.
Experiment control, direct	Crewman mechanically or electronically controls experiment directly (adjust, select modes, identify/acquire targets, react to data, etc.); crewman and experiment are in the same physical location.
Experiment control, remote	Crewman electronically controls experiments indirectly; crewman and experiment are physically separated.
Direct experiment observation	In situ observation of experiment progress; crewman and experiment are in the same physical location.
Remote experiment observation	Observation of an experiment physically located away from crewman (i.e., crewman in orbiter, experiment on pallet); observation either through viewing port/window or TV system.
Housekeeping	Crewman performs activities such as film or tape changing, store/dispose of throwaway items, general cleanup, etc.
Maintenance	Unscheduled or scheduled repair or service activities performed directly (shirtsleeve), remotely (shirtsleeve with manipulator or free flying teleoperator), or EVA.

SOURCE: Marshall Space Flight Center Manned System Specifications.

Table 1 -- continued

<u>Man/System Interaction</u>	<u>Definition</u>
Calibrate instrumentation	Crewman performs procedures (direct or remote) to calibrate or recalibrate instrument prior to or after experiment data taken.
Data reduction/analysis	Crewman reviews experiment data and determines next experiment functions based on that data; redirects emphasis of experiment as necessary.
Remote pallet operations	Display/align/retract booms or antennas on pallet mounted equipment; activities controlled from orbiter or spacelab module.
Free flying teleoperator (FFTO) operations	Checkout, deploy, track, operate (precise on-orbit control from FFTO panel), and retrieve; TV system observation utilized to perform remote tasks.
Subsatellite operations	Checkout, deploy, track, operate (majority of control from ground; on-orbit, control from PSS), and retrieve; observation through window or TV system

#### IV. ROLES OF CREWS IN SPACE EXPERIMENTATION

Development of a new space system can be a long and sometimes frustrating process. Thirteen test launches were required to bring the early Discoverer reconnaissance spacecraft to even a shaky operational status. A multitude of tiny oversights and minor failures, such as circuit breaker trips, fuses blowing, or neglect of a "remove before flight" tag which could be remedied with five minutes of an astronaut's time, have cost hundreds of millions of dollars in lost spacecraft and space experiments.

The coming generation of space experiments, i.e., those carried on a shuttle sortie mission and returned to earth following a test, tries to avoid many of these problems by having crew members, the payload specialists, available for such contingency actions as well as normal operations. In addition, substantial cost reductions may be realized. Equipment can be refurbished and refined for use in subsequent experiments, and much common equipment, such as power supplies, communications, data handling, cooling, and pointing apparatus could be used by several different experiments. Other savings arise since the availability of an intelligent crew to deal with contingencies places less demanding requirements on the experimental designers.

There may be some initial cost increases for payloads not designed for the shuttle since reengineering may be required. Common support equipment for space research must be designed, procured, rated, and installed on the shuttle. The personnel to operate the experiments must be selected and trained. These initial buy-in costs may be seen by some

experimenters as introducing unacceptable delays in programs already delayed by the extended shuttle development program, but when amortized over a large number of experiments conducted over the lifetime of the shuttle fleet, we should ultimately expect to see a greater degree of technical productivity in the cost efficiency of space experiments. An Aerospace Corporation chart showing estimates of cost savings by use of manned sortie missions as opposed to individual free flying satellites for three Air Force space test program experiments is shown in Fig. 2.

The physical configuration of an experiment designed for a sortie mission is seen in Fig. 3. This shows the Space Infrared Experiment in which an infrared telescope is mounted on a pallet in the shuttle bay and the payload specialist operates the bore sight and sensor control equipment from the shuttle aft flight deck.

There are other factors that would tend to lower costs of manned experiments. The intelligence of the human operator who can reconfigure the experiment or make use of spare parts reduces the need for redundant hardware and complex computer programs. A payload specialist, possibly the scientist who designed the experiment or a well trained crew member, can direct the experiment and data collection. This would include real time examination, so that post-flight data reduction costs could be reduced and the probability of making all of the desired observations would be increased. These factors could occasionally make the difference between a fully successful experiment and an experiment which must be reflown in order to acquire data which were missed.

Experimentation and system development on space shuttle sortie missions have limitations as well as advantages. The most significant is the limit on the duration of the test to the maximum shuttle

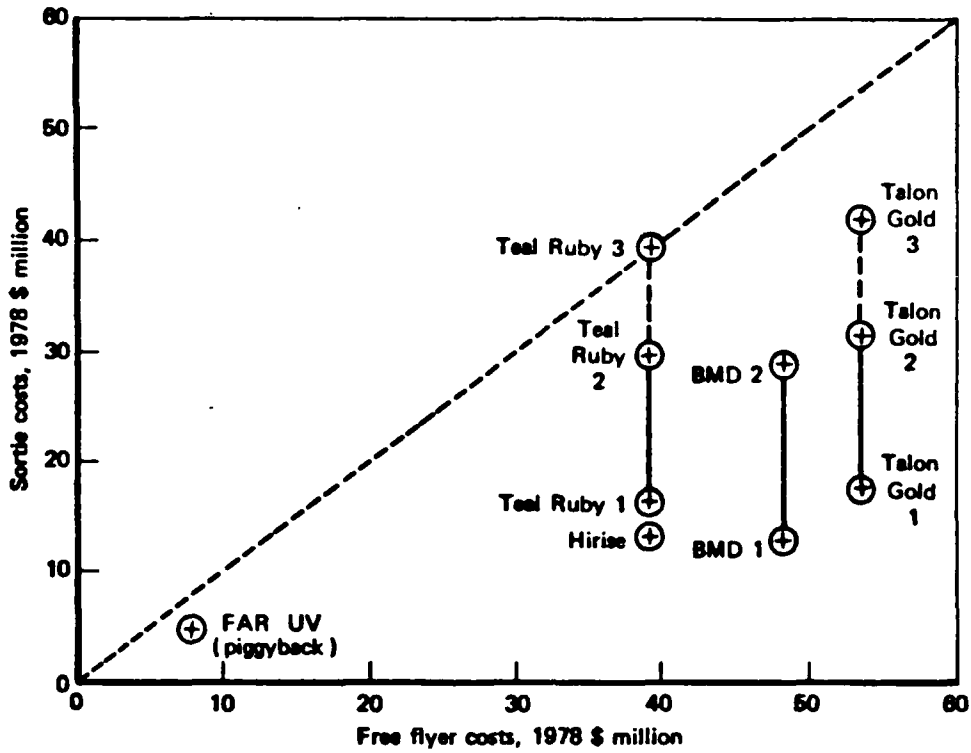
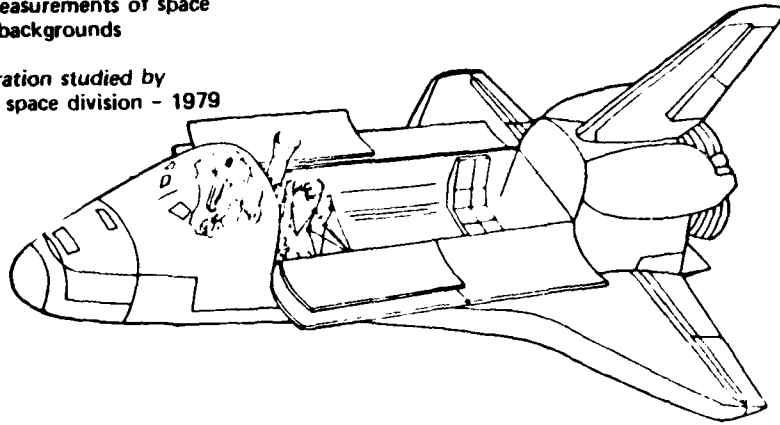
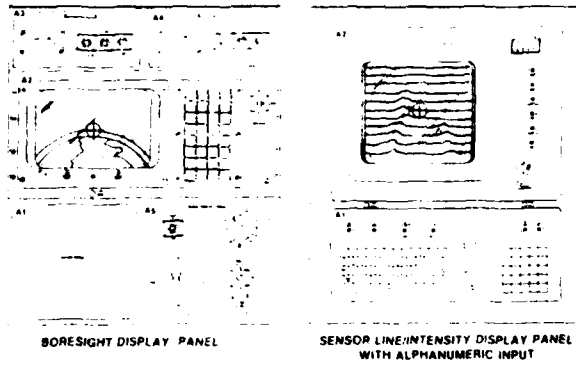

Fig. 2 - 1978 Space Test Program cost estimates of sortie (pallet) missions compared with free flyers. Economies arise from use of shuttle payload support equipment and repeated use of modified experimental apparatus in a series of tests

- Infrared measurements of space targets, backgrounds
- Reconfiguration studied by ORI for space division - 1979



(a) SIRE configuration in the orbiter payload bay



(b) SIRE payload specialist displays aft flight deck

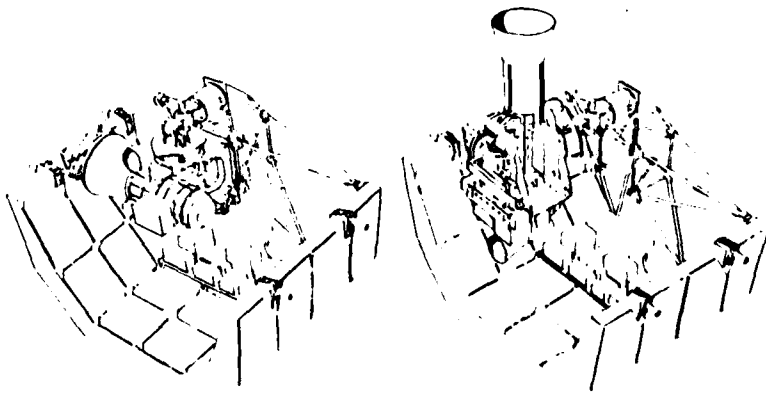

(c) SIRE equipment configuration on shuttle parts

Fig. 3 - Space infrared experiment—SIRE

20-to-30-day mission. Other difficulties include the effects of both chemical and electromagnetic contamination from the shuttle environment, and the power and communications constraints imposed by the shuttle's payload provisions.

These limits have been the motivation for the design of autonomous space experimental platforms, such as the Science and Applications Support platform (SASP), discussed in a subsequent section.

#### V. CREW MAINTENANCE AND SUPPORT OF THE SPACECRAFT

For many missions it is possible to envision a spacecraft that would operate autonomously without a crew for long periods. Service and maintenance would be performed during a manned visit scheduled on a regular preventive basis, or as required by indications of failing or failed components on the spacecraft. If the satellite were in a shuttle-accessible orbit or could be brought into one for service, the crew would have the option of repair in orbit or recovering the satellite and returning it to earth for more extensive reworking.

The absence of a crew on a permanent basis from a spacecraft has certain benefits. Spacecraft sensors themselves can be made larger, and the vibration induced by crew motion will not degrade the quality of the observations. More power will be available for primary mission functions. A fully manned design was considered for the NASA Large Space Telescope but was deemed inappropriate, in part because the motions of the crew members would substantially degrade the pointing accuracy of the apparatus.

We can compare the design of hypothetical manned and unmanned space systems to perform the same mission. Let us assume the lifetime of the program is 15 years and the estimated mean time between failures on the satellite is three years. The manned support option would be to launch a single satellite with manned repair or recovery, scheduled nominally every three years, though conducted on an as-needed basis in order to realize the benefits of extended satellite lifetimes. The unmanned option would be to procure five satellites in a block and launch as they

are required on expendable launch vehicles. For purposes of this comparison, let us assume a cost of \$40 million per ELV launch, \$180 million per manned recovery/refurbishment mission, and \$240 million per satellite. The nominal 15 year program cost based on fixed three-year satellite lifetimes would then be \$1 billion for the manned program and \$1.4 billion for the unmanned. Both program costs will vary with the mean satellite lifetime if recovery and refurbishment missions or new launches are deferred when the satellite in place continues to operate satisfactorily.

The detailed cost comparison of the two programs is strongly sensitive to the assumptions regarding the cost of the individual components. However, an illustrative calculation using these figures is presented here. We continue to assume a 15 year program duration, three year nominal expected satellite lifetime, \$40 million per ELV launch, \$180 per manned recovery refurbishment operation, and \$240 million procurement cost per satellite. The program cost now depends on the satellite lifetime  $L$  as shown below, where the square brackets indicate the greatest integer function.

$$\text{Manned program cost} = \$280\text{M} + [(15/L)-1]*\$180\text{M}$$

$$\begin{array}{l} \text{Unmanned program cost} \\ \left[ \begin{array}{l} = \$1400\text{M} + [(15-5L)/L]*\$280\text{M for } L \leq 3 \\ = \$1240\text{M} + [(15/L)-1]*\$40\text{M for } L > 3 \end{array} \right. \end{array}$$

These equations are graphed in Fig. 4, which shows the dependency of the total program cost on mean satellite lifetime. If the 15 year

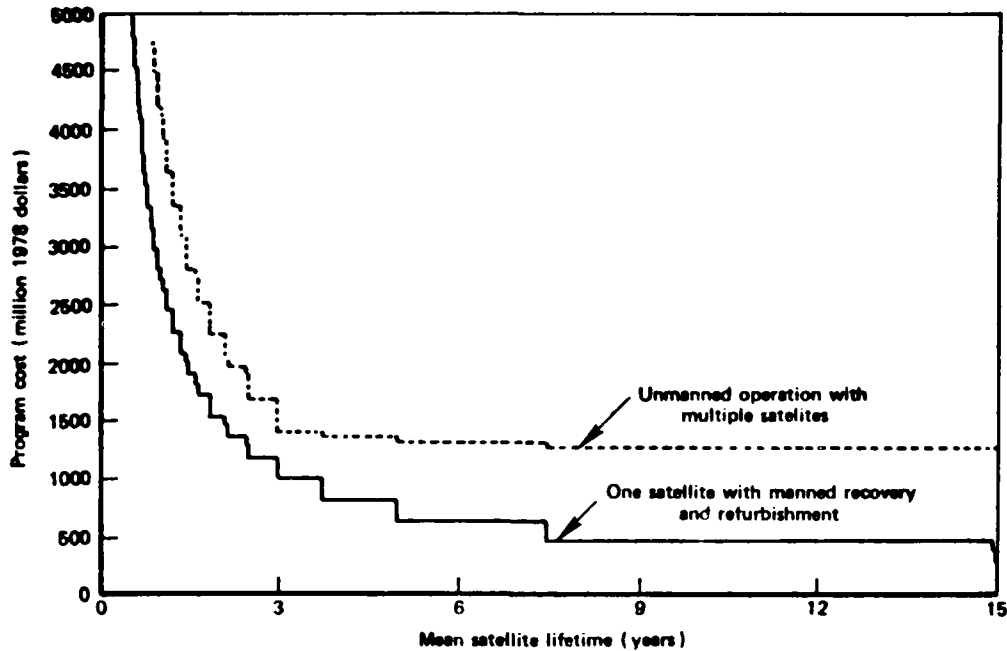

Fig. 4 – Cost comparison of hypothetical manned and unmanned satellite systems discussed in the text

program lifetime assumption is rigidly adhered to, the manned program dominates the unmanned program over all satellite lifetimes, since recovery operations are less costly than new satellites and only relatively small savings are realized by eliminating ELV launches. In fact, it is unlikely that the unmanned program would continue in the way shown in this chart for lifetimes less than three years. In the face of multiple early failures the satellites would be extensively evaluated and redesigned rather than replicated and relaunched repeatedly. There are many other difficulties with this sort of cost comparison; reasonable alternative programs are not included, and the results are very sensitive to initial assumptions.

The manned and unmanned systems can be compared in dimensions other than cost. First, in versatility. A single satellite system with manned servicing would require recovery, refitting, and replacement to substantially modify the satellite. The cost of this kind of activity would be much higher than that incurred in modifying a satellite already in production. The other side of this issue is that long satellite lifetimes with adequate performance result in substantial savings (\$180 million per cancelled manned service mission compared to only a \$40 million savings per cancelled ELV launch in the previous example). In the case of short satellite lifetimes, the schedule of manned service missions can be accelerated. If short lifetimes persist despite efforts to improve reliability, the conventional program would continue only with larger increased costs for valuable payloads such as the one discussed here.

In the manned program, the possibility of accidents in which the crew inadvertently damages the satellite will always exist. This will not occur in a conventional program. A major advantage offsetting this risk is the far simpler recovery from certain electromechanical accidents in a manned program.

A single catastrophic event destroying the satellite will require termination of the single satellite manned program, while an accelerated launch schedule can allow the conventional program to proceed as long as satellites remain in inventory or production.

The collateral opportunities in the manned program include the experimental test of the utility of crews in space, which we have been waiting for, but exclude the possibility of multiple satellite

observations. The conventional program does nothing to further resolve the questions of human space capabilities, but if satellite lifetimes are extended and multiple platforms placed in space at the same time, additional observation opportunities can arise.

Another risk in the manned program is that the satellite may become unserviceable, or fail catastrophically during a service visit, in the worst case causing the loss of the crew and shuttle as well as itself. In the conventional satellite program only the loss of equipment, satellites, and ELVs can occur.

Irrespective of the particular numbers involved, it is clear that certain very expensive satellites using fuel, film, and other consumables, both for today's passive or tomorrow's active military functions, could benefit from manned servicing. This would be even more so in the case of orbiting space weapons systems requiring a large number of platforms arranged in orbits such that multiple visits could be accomplished in a single shuttle mission.

## VI. MANNED SPACE RESEARCH AND DEVELOPMENT PLATFORMS

The discussion of experimentation on shuttle sortie missions earlier in this paper noted the limitations as well as the advantages of sortie R&D activities, particularly the 20-to-30-day limit on mission duration, imposed by use of the shuttle as the experimental platform.

To circumvent these limits, NASA has undertaken detailed studies of systems to support manned space Research, Development, Testing and Evaluation (RDT&E). This system is called the Science and Applications Space Platform (SASP) and is described in Ref. 7. SASP is a proposed shuttle cargo to be placed in orbit as a long-term base for large payloads. Crew involvement levels could include setup and maintenance, or extended operation from a habitat module. The SASP would be similar to the Long Duration Exposure Facility (LDEF) in that it stays in low orbit and is serviced by shuttle flights over a period of years. But unlike the LDEF it would provide support functions to experiments in a manner compatible with the sortie. Electric power, computer support, data services, stabilization, and heat radiation could all be handled by centralized systems. The central computer would operate the platform, and individual experiments could operate under the control of smaller dedicated computers.

NASA's study concluded that major improvements in low earth orbit payload accommodations could be provided over the sortie mode with minimal payload conversion. Experiments would benefit from longer flight duration, an environment without chemical and electromagnetic contamination from the shuttle, greater heat dissipation and power, greater viewing freedom, and lower cost per day of flight.

There would also be reductions in the load on NASA support systems, such as the TDRSS and the shuttle itself. The SASP package of resources available for payloads would free the experimenters from having to provide their own solar arrays, antennas, radios, recorders, etc., and thus would be an economical alternative to a series of smaller free-flying spacecraft.

Illustrations comparing the two proposed designs for the first- and second-order Science Application Support Platforms and the shuttle cargo bay sortie are shown in Fig. 5.

Neither of the designs shown include a long-term crew habitation module, as would be required for a resumption of manned space activity as was conducted in the American Skylab and Soviet Salyut programs. Crew involvement on an unmanned SASP would be limited to initialization, maintenance, and equipment change-outs during brief visits.

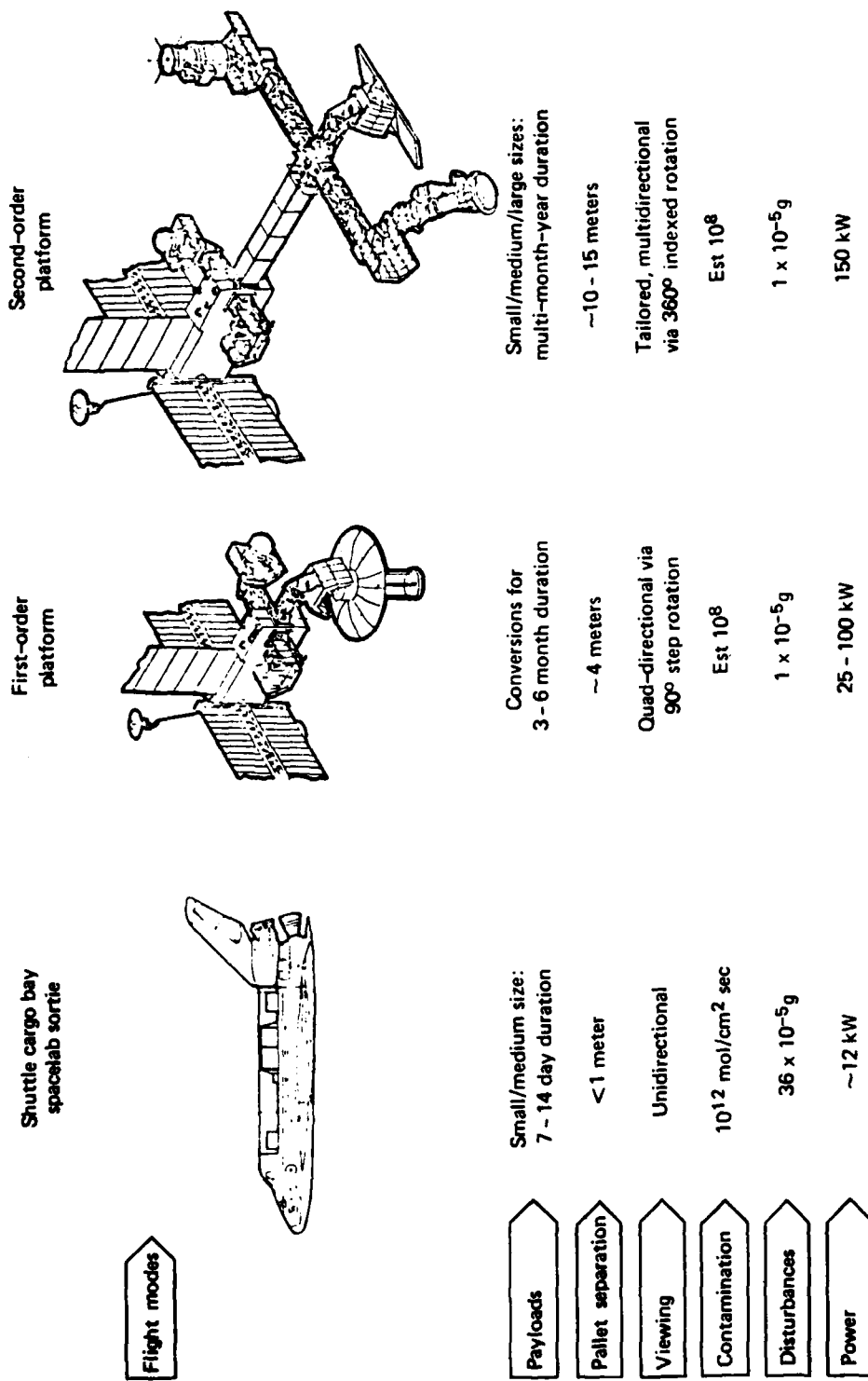

Fig. 5 - Science Application Support Platforms compared with orbiter payload accommodations

## VII. ACTIVE CREW OPERATION OF CONTINUOUSLY MANNED FACILITIES

An orbiting space station, long envisioned by writers of science fiction, is now viewed as a potentially valuable asset in the development, deployment, operation, maintenance, and recovery of both military and commercial spacecraft, as well as the conduct of space operations. Space station concepts range from the modest, such as the manned habitation module attached to an SASP as described earlier, through a full-blown multiport structure capable of accommodating large crews involved in the construction and service of large space systems.

The only currently funded manned experimental program to provide a Skylab-like environment is the ESA Spacelab (Ref. 8), itself a sortie mission payload. It has the same duration, power, and heat limitations imposed on other payloads. Spacelab, as seen in Fig. 6a, is a modular system consisting of various manned modules and unmanned equipment pallets installed in the shuttle bay.

The detailed illustration in Fig. 6b shows the major features of Spacelab. A tunnel connects Spacelab to the lower crew area in the shuttle. In some configurations, Spacelab has its own airlock, allowing specialists to service or operate external equipment without interfering with cabin activities on the orbiter.

As commodious as the Spacelab accommodations may be, they are short-term facilities, limited to a few weeks of continuous use at a time. In a recent study (Ref. 9), the Aerospace Corporation has examined the possibility of an independent Spacelab, modified to support a crew of three for 90 days. Their design proposal (see Fig. 7a) is based on the

- 1 Long module configuration
- 2 Long module + 3 m pallet configuration
- 3 Long module + 6 m pallet configuration
- 4 Short module + 6 m pallet configuration
- 5 Short module + 9 m pallet configuration
- 6 9 m pallet configuration
- 7 12 m pallet configuration
- 8 15 m pallet configuration

Besides these basic configurations, other arrangements of modules and pallets are possible

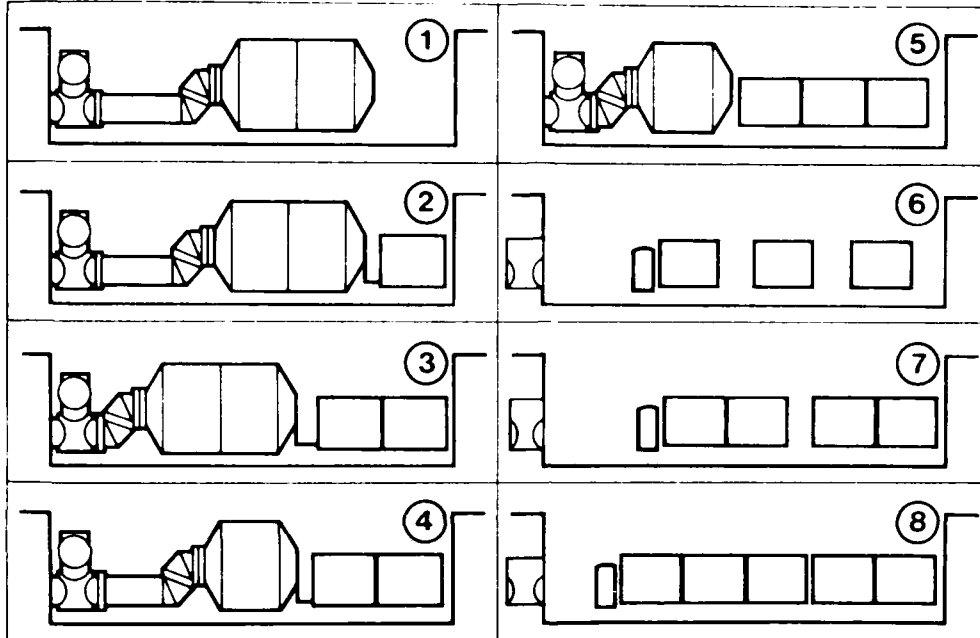

SOURCE . ref. 8

Fig. 6a - Spacelab basic configurations

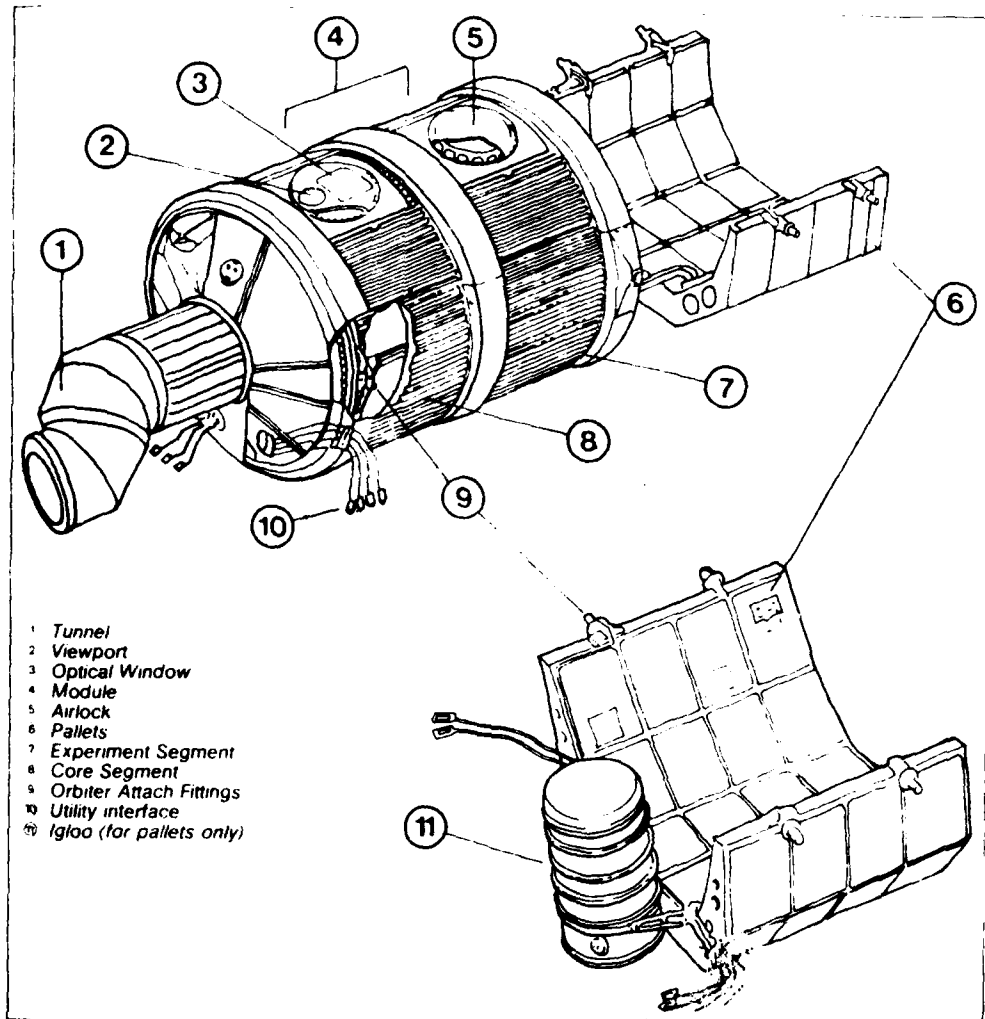

SOURCE : ref. 8

Fig. 6b - Spacelab main external features

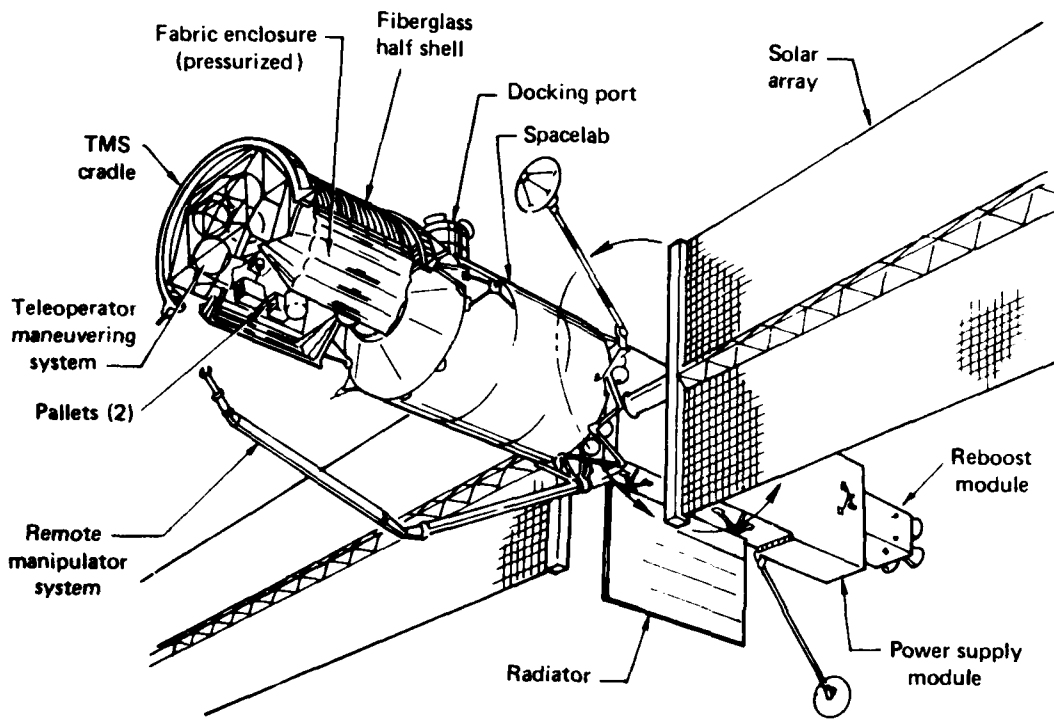

SOURCE: ref. 9

Fig. 7a - Shuttle Independent Spacelab with shirtsleeve service module

use of current or planned hardware elements--the 25 kilowatt solar power module is under development by NASA for extended STS and SASP operation, the Remote Manipulator System arm has, of this writing, been flown on two shuttle missions, and the reboost module and other support equipment are based on Skylab designs.

The shirtsleeve satellite service area is composed of Spacelab pallets enclosed in a new pressurized fiberglass fabric enclosure. The original Spacelab long habitation module is extended by an additional segment to accommodate the crew and equipment that would otherwise be carried on the orbiter. Layout of the habitation module is shown in Fig. 7b.

A major new component is the Teleoperator Maneuvering System (TMS), a remotely controlled vehicle designed to travel as far as GEO to extend the range of manned satellite serviceability. This is one of a number of proposals for such reusable transfer vehicles; others are discussed in a later section.

The launch configuration for an Independent Spacelab on a single Shuttle Derivative Launch Vehicle is seen in Fig. 7c. Shuttle launch would require two separate missions, one to carry the habitation module, another for the power system, with assembly by docking in orbit.

Development cost for an Independent Spacelab is estimated at \$2 billion, though such preliminary estimates must be regarded with some caution.

The facility would make good use of existing components and thus allow a relatively modest investment to substantially expand the planned U.S. crew presence in space. Evaluation of the services provided and

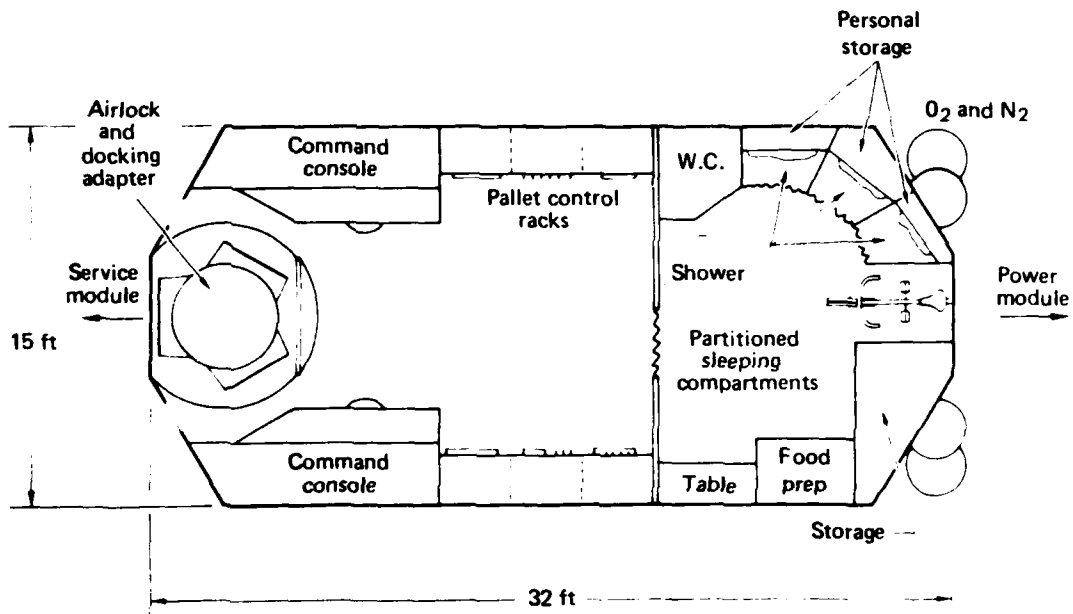

SOURCE: ref. 9

Fig. 7b - Spacelab habitation module  
Top view

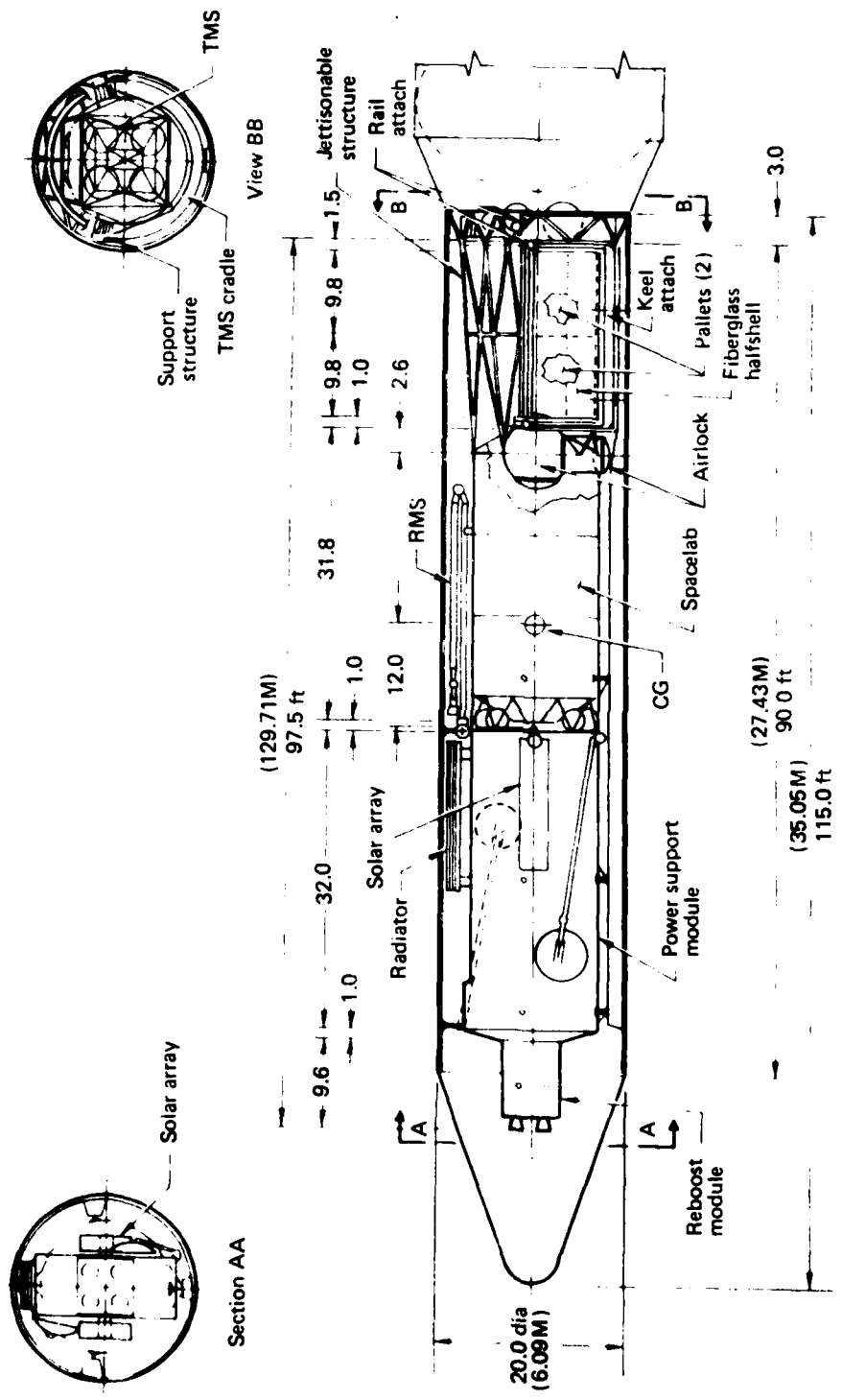

SOURCE: ref. 9

Fig. 7c - Launch configuration for shuttle derived launch vehicle

experimental results of a small facility such as this could form the basis for a decision on more elaborate platforms, such as the Space Operations Center (SOC).

The Space Operations Center is a less modest undertaking of potential military importance (Ref. 10). This is a NASA concept which could evolve from a small initial configuration to a full-blown high-volume satellite construction and service facility, serving a wide range of military and civilian missions. One evolutionary path for the SOC is seen in Fig. 8, while Fig. 9 details the full reference configuration.

Much more needs to be known about the relative economies and abilities of crews performing construction and heavy maintenance tasks in space before one can reach an informed decision on whether to initiate such a program and which design should be pursued. We have very limited experience with crews performing tasks in space. It is important that we begin our experimentation soon to determine what is feasible and desirable in this area.

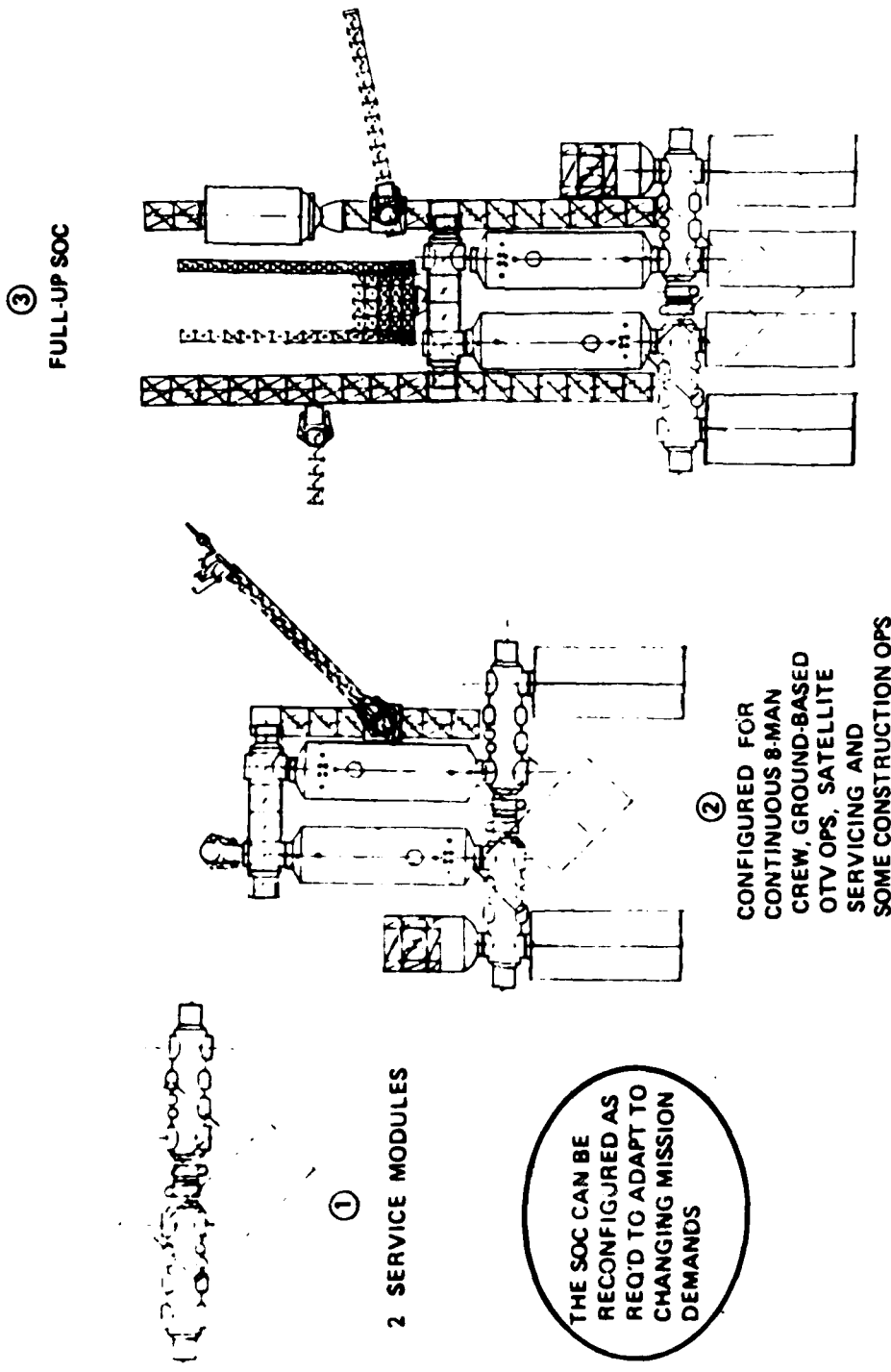
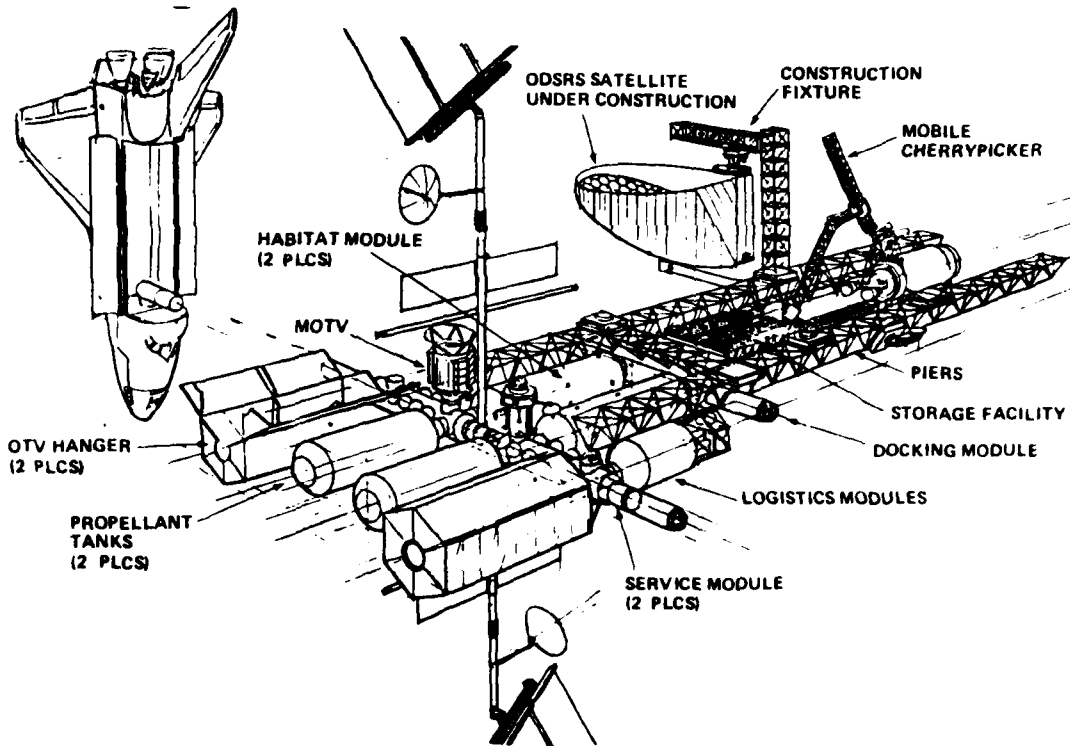

Fig. 8 -- SOC build-up evolution concept



**Fig. 9 – A NASA concept for the Space Operation Center (SOC). This is a large configuration, with extensive facilities for satellite construction and servicing. It is unlikely that a Space Transportation System consisting of just four shuttles could support the construction of such a base, or the level of space activity required to justify it. A single SDLV launch could place the components in orbit, replacing at least five shuttle missions**

### VIII. ADVANCED DEPLOYMENT CONCEPTS

The space operations that have been proposed for the remainder of this century are principally in low earth orbit or at geostationary altitudes. Looking further into the future it is reasonable to ask whether we will confine our activities to LEO and GEO. The answer given by many futurists is that we will not be confined to these locations in space, our domain will expand to encompass the earth-moon system.

In addition to the earth and moon there are five points of interest in the earth-moon systems. These are the LaGrangian points (known as L-1 through L-5), where the gravitational forces exerted by the two bodies are such that an object at one of these points will remain at that point. Of the five points, shown in Fig. 10, only two (L-4 and L-5) are stable, i.e., slight perturbations in the position of an object result in restorative forces which tend to maintain the equilibrium. The others are of less interest, since a space platform trying to maintain position at L-1, L-2, or L-3 would require substantial energy expenditures just to maintain its position.

Stine, in Ref. 2, discusses the military importance of L-4 and L-5. Each of these points is situated at the top of a pair of gravitational "wells," one going down toward the earth and the other toward the moon, as shown in Fig. 11. A platform placed at L-4 or L-5 has considerable strategic importance in the earth-moon system since gravity assists the transfer of mass to the earth or moon and resists any effort to transfer mass to the equilibrium point from the earth or moon. This is a case

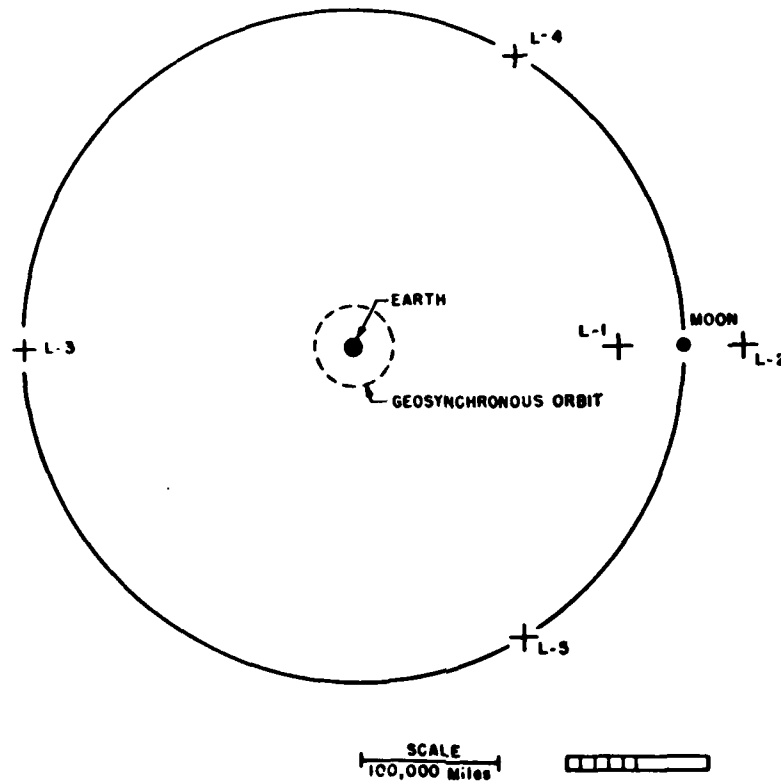

SOURCE: ref. 2

Fig. 10 - LaGrangian points in the earth-moon system

where the "high ground" analogies of some military space planners are quite appropriate.

It should be noted, however, that occupation of the L-4 and L-5 "high ground" offers no additional protection from directed energy devices.

The use of these points for any purpose, military or civilian, is many years away. Decisions regarding them will be made in political and technological contexts that differ greatly from today's circumstances.

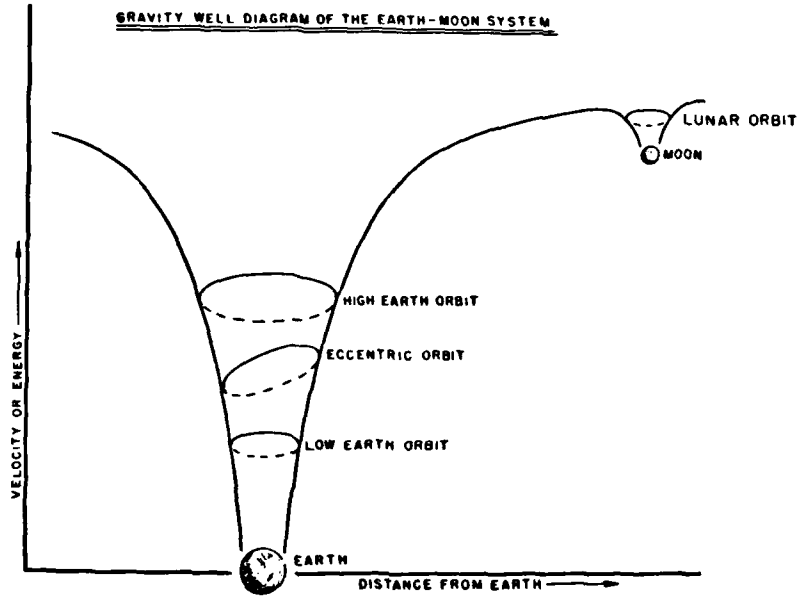

SOURCE: ref. 2

Fig. 11 - Gravitational well diagram of the earth-moon system  
(not to scale)

### IX. MANNED MILITARY SPACE VEHICLES

While illustrations of space stations often show one or two space shuttles parked nearby, actual operations will require the development of a different kind of vehicle, designed for use only in space, and not intended to cross the atmospheric barrier. Such a vehicle would be lighter, smaller, and far less expensive than the shuttle, which must operate in space and in air, two very different environments.

The primary reason to develop a space-only vehicle is that the shuttle will be needed for its space launch missions, and will not be available to any great extent for ongoing orbital operations. The need for the vehicle arises as well from the orbital limitations of the shuttle, which can reach only as high as 600 miles, whereas many military payloads orbit at altitudes far beyond, and almost all commercial payloads (desirable as cost sharers for any manned space operation) are in geosynchronous orbit.

The Teleoperator Maneuvering System (TMS), seen in Fig. 6a attached to the Independent Spacelab, is one such vehicle, envisioned as an unmanned robot. Another utility vehicle for manned operations, proposed by Bud Redding of the Stanford Research Institute, is seen in Fig. 12.

Orbital transfer vehicles are essential for a mature operation in space. Support and additional propulsion modules could be added external to the vehicle, since it would never be required to fly through the atmosphere and no streamlining would be necessary. It could be operated in a manned or autonomous mode as deemed appropriate for the mission. A known minor component replacement for a satellite in

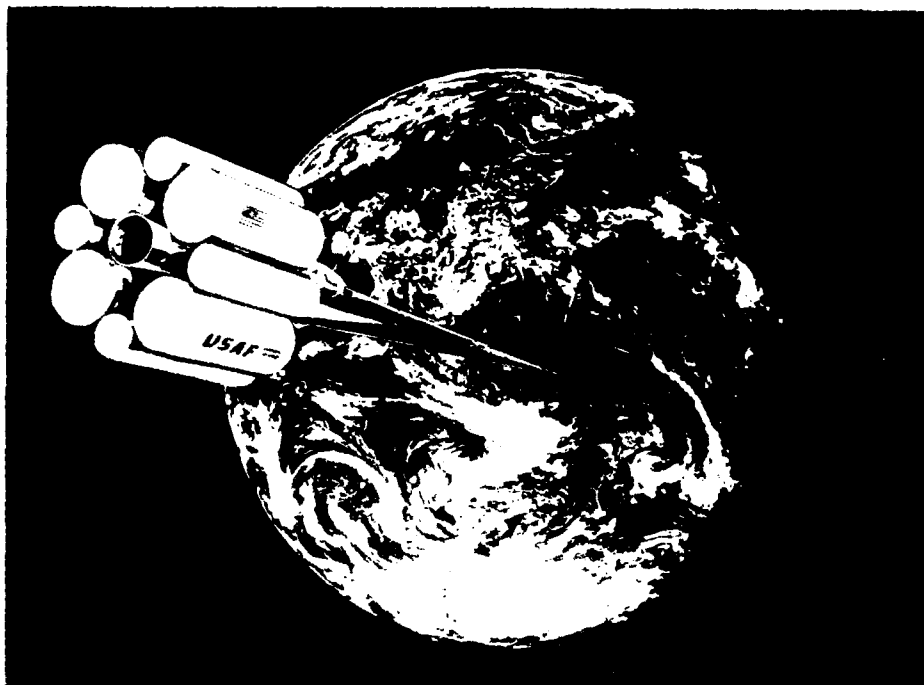

Fig. 12 – The High Performance Space Plane is a proposal by the Stanford Research Institute for a reusable general purpose space vehicle. Auxiliary fuel and payloads are carried outside the vehicle. The exterior modules are jettisoned, leaving a conical reentry vehicle, which is recovered by parachute drop

geosynchronous orbit would certainly not call for bringing a large and potentially delicate satellite down into low earth orbit. A crew member would be sent to do the job as a "housecall." An undiagnosed failure on a nearby satellite would justify a recovery mission.

The transfer vehicle would need some means of dealing with satellites spinning out of control. This is an area of considerable uncertainty, but it is clear that direct personal action by crew members

would be unwise. Grappling systems or nets operated by remote teleoperators would be more appropriate.

## X. ANOTHER APPROACH

Much of the preceding discussion has been based on the implicit assumption that it is useful and economical to place crews in space to perform complex functions. This may well be the case in peacetime, but during a period of hostilities the use of an SOC or similar base may well be denied even though the nation's military need for space operations would be substantially increased. There are proposals for hardened silo launchers to place small payloads in space, but this does not allow for the flexibility and adaptability of manned operations. Thus, another approach to the military use of space is that of quick turnaround, single-stage to orbit, Reusable Aerodynamic Space Vehicles (RASV). One such vehicle is seen in Fig. 13. This is a Boeing concept for a RASV using space shuttle main engines in a wet wing airframe holding the cryogenic fuels. With slight upgrading in the SSME thrust rating, such a vehicle could place payloads of over 30,000 lb in 28.5 degree orbits and over 15,000 lb in 100 mile polar orbits with takeoff turnaround times measured in hours. This design is actually reminiscent of the original proposals for the shuttle, which were based on similar advanced materials technology. The metal exterior of the craft would eliminate the turnaround delays associated with tile maintenance as found in the shuttle, and other systems would also benefit from shuttle experience.

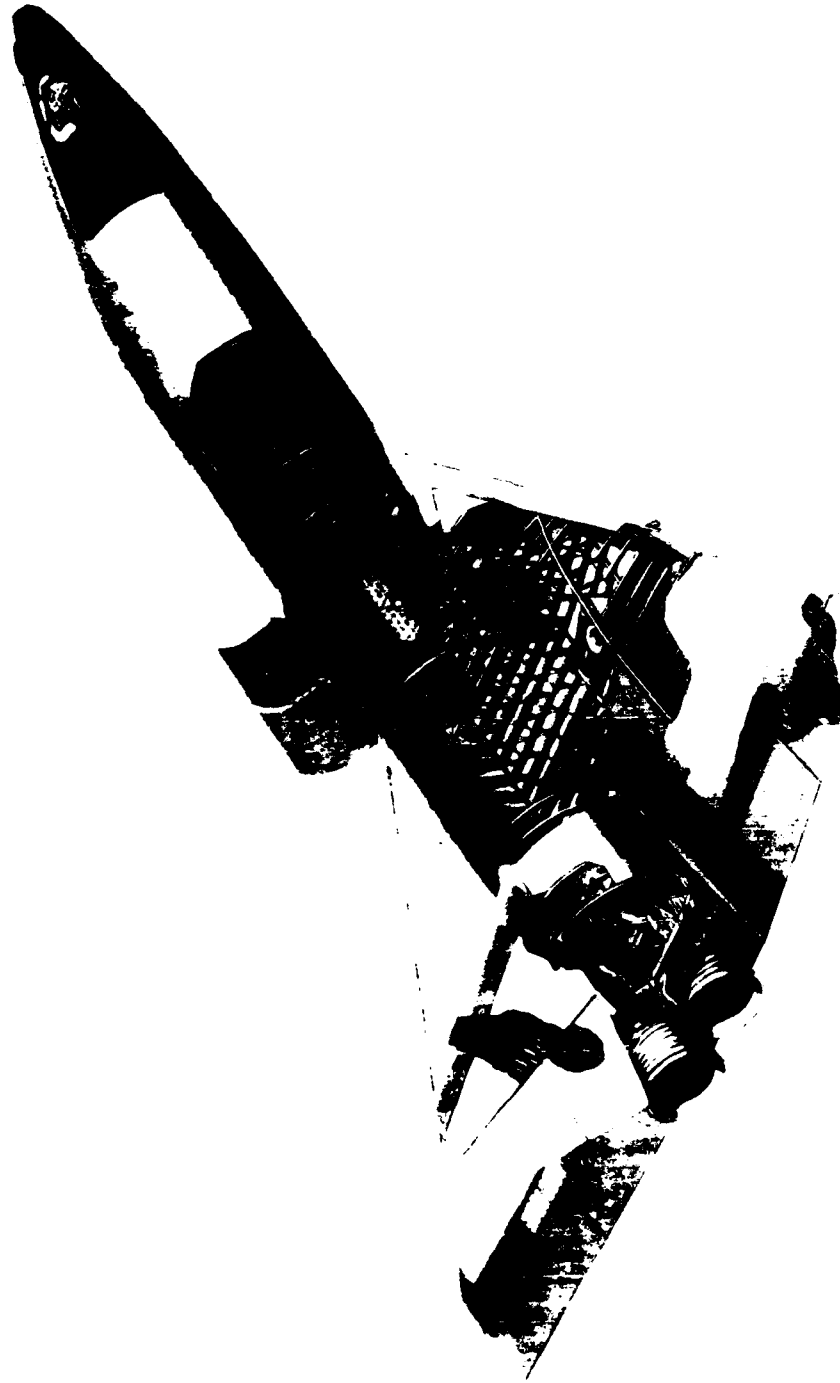

Courtesy of Boeing Aerospace

Fig 13 — Rocket powered aircraft based on space shuttle main engines employed in a new "wet" airframe using advanced structural concepts to achieve light weight and strength while holding cryogenic fuels

XI. CONCLUSIONS

An examination of the future military roles of crews in space has aspects of a problem embedded in a dilemma. We have yet to define our military space goals or impose limitations. Organizations to carry out required training and development activities have not yet fully emerged. What is needed today above all else is a commitment to explore the possibilities, to experiment, and to acquire a sound knowledge base on which to make an informed judgment on the future military role of men in space.

REFERENCES

1. Klass, Philip J., Secret Sentries in Space, Random House, New York, 1971.
2. Stine, G. Harvey, Confrontation in Space, Prentice-Hall, Englewood Cliffs, New Jersey, 1981.
3. SIPRI Yearbook 1977, World Armaments and Disarmament, MIT Press, Cambridge, Massachusetts, 1977.
4. Project Nereus--Executive Summary, Scripps Institution of Oceanography, ONR West Special Publication No. 81-1, February 1981.
5. Visual Observations of the Ocean, by R. Stevenson, L. P. Carter, S. P. Van der Haar, and R. O. Stone, in Skylab Explores the Earth, NASA, 1976.
6. Antipodal Seas, by R. Stevenson, Apollo-Soyuz Test Program Summary Science Report, NASA Special Publication SP-412, Vol. 2, 1979.
7. Conceptual Design Study: Science and Applications Space Platform (SASP) Final Briefing, McDonnell Douglas Corp., Huntington Beach, California, MDC 69300, October 1980.
8. Spacelab Users Manual, European Space Agency Document No. DP/ST(79), July 1979.
9. Baker, J. C., T. A. Cortes, and E. B. Mayfield, Independent Spacelab, The Aerospace Corporation Report No. TOR-0082(2071-05)-1, January 1982.
10. Space Operations Center System Analysis, Midterm Briefing, Boeing Aerospace Company, Seattle, Washington, D180-26209-1, December 1980.

PRECEDING PAGE BLANK-NOT FILMED

ENI

DATE

FILME

2-83

DTIC

House, New York,

-Hall, Englewood

nt, MIT Press,

tion of  
1, February 1981.

L. P. Carter, S.  
es the Earth,

Program Summary  
ol. 2, 1979.

Space Platform  
tington Beach,

nt No. DP/ST(79),

ependent  
0082(2071-05)-1,

iefing, Boeing  
1, December 1980.

BLANK-NOT FILMED