

AD-A122 956

SHORT RESISTANT COLLECTING CELLS FOR ELECTROSTATIC  
PRECIPITATORS(U) TRION INC SANFORD NC 30 NOV 82  
N00014-82-C-2225

1/1

UNCLASSIFIED

F/G 13/2 . NL

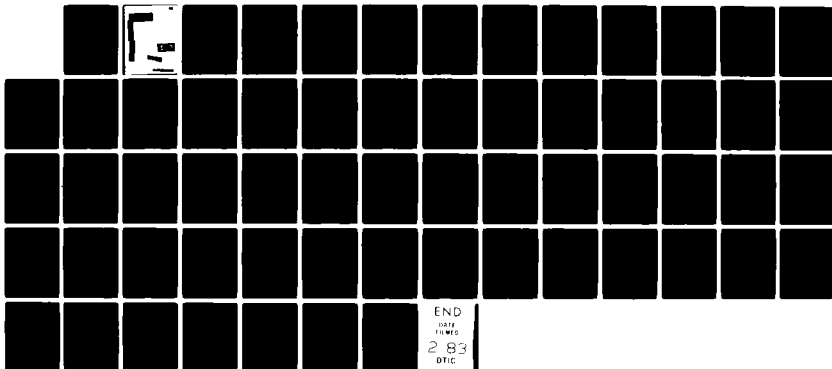

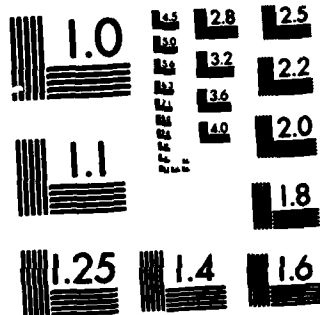

MICROCOPY RESOLUTION TEST CHART  
NATIONAL BUREAU OF STANDARDS-1963-A

12

Development Report  
Short Resistant Collecting Cells  
for Electrostatic Precipitators  
Contract N00014-82-C-2225

AL A 122956

DIC FILE COPY

DIC  
S JAN 4 1983 H

DISTRIBUTION STATEMENT A  
Approved for public release;  
Distribution Unlimited

82 12 08 028

12

SHORT RESISTANT COLLECTING CELL

Presented by Trion, Inc., Sanford, N.C.,  
Under Contract to Naval Research Laboratory  
Washington, D.C.

Contract N00014-82-C-2225

DTIC  
JAN 4 1983  
H

November 30, 1982

**DISTRIBUTION STATEMENT A**  
Approved for public release;  
Distribution Unlimited

SHORT RESISTANT COLLECTING CELL INDEX

<u>Description</u>	<u>Page</u>
List of Tables	II
List of Figures	III
References	IV
Abstract	1
Contract Objective	2
Introduction	3
Present Design	5
Short Resistant Design Concept	7
Resistive Plate Cell	10
Resistive Bus Cell	14
R-C Spacer Cell	16
Semiconductive Materials Tested	22
Summary	24
Recommended Future Efforts	27

Accession Per	
NTIS GRA&I	<input checked="" type="checkbox"/>
DTIC TAB	<input type="checkbox"/>
Unannounced	<input type="checkbox"/>
Justification	<i>for file</i>
By <i>[Signature]</i>	
Distribution/	
Availability Codes	
Dist	Avail and/or Special
A	



LIST OF TABLES

<u>Table</u>	<u>Title</u>	<u>Page</u>
1	Resistive Plate Cell Efficiency 10"	31
2	Resistive Plate Cell Efficiency 6"	32
3	R-C Spacer Cell Efficiency	33
4	R-C Spacer Split Plate Cell Efficiency	34
5	Collecting Cell Efficiency Comparison	35

## LIST OF FIGURES

<u>Figure</u>	<u>Title</u>	<u>Page</u>
1	Standard Collecting Cell	36
2	Standard Cell Cutaway	37
3	Standard Cell Schematic	38
4	Resistive Plate Cell Cutaway	39
5	Resistive Plate Cell Schematic	40
6	Resistive Sleeve Detail	41
7	Resistive Sleeve Cell	42
8	Resistive Sleeve Cell with Fault	43
9	Resistive Bushing Detail	44
10	Resistive Bushing Cell	45
11	Resistive Bushing Cell with Fault	46
12	R-C Spacer Cell Schematic	47
13	R-C Spacer	48
14	R-C Spacer Cell Plate Configuration	49
15	Insulated Spacer	50
16	R-C Spacer Cell	51
17	Split Plate	52
18	R-C Spacer Split Plate Cell Construction	53
19	R-C Spacer Split Plate Cell Detail	54
20	Testing Fixture for Spacer	55

REFERENCES

1. Naval Research Laboratory Contract N00014-82-C-2225 dated 7 June 1982.
2. Military Specification MIL-F-22963B (SHIPS) 21 December 1973 Filter, Air, Electrostatic (Precipitator) With Power Supply for Environmental Control Systems
3. U. S. Patent 4,166,729 dated September 4, 1979 Collector Plates for Electrostatic Precipitators
4. IAS Conference Record, September 1980 Short-Resistant Two-Stage Electrostatic Precipitator Designs
5. Trion, Inc. Invention Disclosure No. 49 dated May 17, 1982 "Smoke Control Electronic Air Cleaner"
6. Trion, Inc. Invention Disclosure No. 50 dated May 21, 1982 "Non-Arcing and Short Resistant Collecting Cell"
7. Trion, Inc. Invention Disclosure No. 51 dated November 23, 1982, "Non-Arcing and Short Resistant Collecting Cell with Split High Voltage Plates"

Abstract

Prototypes of two different short-resistant electrostatic precipitator collecting cells have been designed, fabricated and tested. Both designs can meet all the performance requirements of MIL-F-22963B<sup>1</sup> and can be retrofitted in presently installed modular electrostatic precipitators. Both designs appear capable of prolonged operation under heavy smoke loading conditions to effectively cleanse a submarine atmosphere of smoke from a fire. The prototypes have been delivered to the Naval Research Laboratory for smoke loading tests to evaluate their effectiveness.

- 
1. Military Specification MIL-F-22963B (SHIPS) 21 December 1973, Filter, Air, Electrostatic (Precipitator) with Power Supply for Environmental Control Systems.

## Contract<sup>2</sup> Objective

The purpose of this contract<sup>3</sup> was to determine the feasibility of modifying the design of the collecting cell presently used in the modular electrostatic precipitators to provide extended operating life under conditions of heavy smoke loading. The constraints imposed on the design were that the modified cells were to be adaptable to retrofitting in presently installed modular electrostatic precipitators and comply with all the requirements of equipment specification MIL-F-22963B<sup>4</sup>.

The objective of the contract<sup>5</sup> was to provide functional prototypes of two different designs of short-resistant collecting cells to the Naval Research Laboratory for testing under heavy smoke loading conditions. A final technical report of the results of the research and development work was to be provided including recommendations for future efforts to develop a commercially practicable shipboard smoke control system.

---

2. Naval Research Laboratory Contract N00014-82-C-2225 dated 7 June 1982.

3. Ibid.

4. Military Specification, op. cit.

5. Naval Research, op. cit.

## Introduction

A fire on a submarine can prevent the boat from fulfilling its mission because of the smoke generated by the fire. Most submarine fires can be quickly controlled and extinguished through the present damage control procedures. After the fire is extinguished, the existing life support equipment can replace the oxygen consumed by the fire and remove the hazardous gases generated by the fire. However, the dense concentration of smoke overloads the presently installed electrostatic precipitator (ESP), the primary source of airborne contaminant control in the submarine atmosphere, causing rapid failure of the ESP. With the failure of the ESP, smoke removal to restore normal visibility requires the submarine to surface or snorkel to ventilate the atmosphere. Surfacing or snorkeling may not be practicable in a tactical situation.

The ESP's presently installed in submarine ventilation systems are designed for the collection of the light concentrations of aerosols typically found in habitable atmospheric air. The ESP's are periodically washed to remove the collected particulates. A heavy concentration of aerosols, resulting from a shipboard fire, rapidly bridges the insulative air gaps between the high voltage and grounded collector plates. This causes an overload of the power supply and failure of the ESP. Previous laboratory tests have demonstrated that a conventional ESP will become inoperative in a few seconds under heavy smoke concentrations and become ineffective in removing the smoke.

Personnel of the Naval Research Laboratory (NRL) have developed two theoretical concepts<sup>6,7</sup> for the design of short-resistant ESP collecting cells to prolong the operating life of the ESP under conditions of heavy smoke loading. The short-resistant cells are intended to provide a sufficient operating life to enable the ESP's to cleanse the submarine atmosphere of smoke after a fire and eliminate the need to surface ventilate the smoke.

The task of this contract<sup>8</sup> was to design two or more types of short-resistant ESP collecting cells and provide prototypes to NRL for testing under conditions of heavy smoke loading. The short-resistant cells were to comply with all the requirements of the ESP specification, MIL-F-22963B<sup>9</sup>, and be suitable for retrofitting in the presently installed modular ESP's.

- 
6. U.S. Patent 4,166,729 dated September 4, 1979, Collector Plates for Electrostatic Precipitators.
  7. IAS Conference Record, September 1980, Short Resistant Two-Stage Electrostatic Precipitator Designs.
  8. Naval Research, op. cit.
  9. Military Specification - op. cit.

### Present Design

The standard ESP collecting cell is shown in Figures 1 and 2. The cell is composed of a series of electrically conductive parallel aluminum plates. Each alternate plate is directly connected to a high voltage direct current power source through a high voltage contact and bus bars. The remaining plates are electrically grounded. Each pair of high voltage or grounded plates is separated by cylindrical aluminum spacers over the bus bars which pass through electrical clearance holes in the oppositely charged plates. The electrical circuit is shown schematically in Figure 3.

Aerosols are electrically charged as they pass through the ionizing section of the ESP. When the charged particles enter the collecting cell, they are repelled by the high voltage plates and attracted to the grounded plates by the electrostatic field which exists between adjacent plates. The particles are collected on the grounded plates where they adhere by molecular force.

As collected particles accumulate in the collecting cell, the insulating air gap between the high voltage and grounded plates is reduced, resulting in electrical arcing between the plates. The energy of the electrical arc is sufficient to carbonize the collected particles, which reduces their electrical resistance and induces further arcing. Eventually the accumulation of carbonized particles bridges the gap between the plates causing



### Short-Resistant Design Concept

Electrical arcing and overload of the power supply are the primary causes of ESP failure. The design for a short resistant ESP collecting cell requires:

1. Minimizing the electrical energy available for arcing.
2. Eliminating/reducing the frequency of arcing.
3. Minimizing the current draw from the power supply under a short circuit condition.

In the present collecting cell, each high voltage plate and the adjacent ground plate is an energy storage capacitor. Since all high voltage plates are directly connected electrically, the energy available for an electrical arc is the sum total of the capacitance of all the plates in all the collecting cells of the ESP.

Electrically isolating the high voltage plates from each other through a resistance-capacitance (R-C) network limits the energy available for an electrical arc to only the capacitance stored in a single plate capacitor. Also, the R-C network permits any number of high voltage plates to be shorted to ground without drawing excessive current and overloading the power supply. The unshorted high voltage plates retain their electrical charge and remain operational. Further, if the electrical resistance is embodied on the surface of the high voltage plate, a short circuit will affect only the immediate area of the short while

the rest of that high voltage plate and all other plates remain charged.

The principle employed in applying the R-C network to achieve a short-resistant ESP collecting cell is to control the time constant to charge or discharge a capacitor. A time constant longer than the duration of an electrical arc prohibits any contribution to the potential energy available for an arc from the total system capacitance. Thus, the energy available for an arc is limited to the energy stored in a single plate capacitor, which may be insufficient to carbonize collected material in the cell. Further, the resistance in the R-C network limits the current flow of a short circuit.

The time constant to charge or discharge a capacitor is the product of the capacitance and the resistance. The equation for the time constant is  $T = R \times C$  where:

T = time in seconds

R = resistance in ohms

C = capacitance in farads

The capacitance of a collecting cell is fixed by the area and spacing of the plates. The capacitance of a typical 6" wide collecting cell having 9 high voltage plates and 10 grounded plates, as used in these tests, was measured at 1600 pico farads (pfd) or  $1600 \times 10^{-12}$  farads. The capacitance between each high voltage plate and the two adjacent grounded plates is 178 pfd.

We estimated that a time constant of 0.1 seconds for the charge/discharge of the single plate capacitor would be longer than the duration of an electrical arc and would be effective in controlling arcing. The resistance required for this TC is:

$$R = \frac{0.1 \text{ Seconds}}{178 \times 10^{-12} \text{ Farad}} = 562 \times 10^6 \text{ ohms} = 562 \text{ megohms}$$

The time constant for each high voltage plate and its associated capacitance can be controlled by selecting the resistance in series with that capacitance. Two methods were proposed by the Naval Research Laboratory: (1) low conductivity plates<sup>10</sup> and (2) a high resistive, low conductivity bus connecting the plates to the power supply<sup>11</sup>. The low conductivity plate concept is described in U.S. Patent 4,166,729 "Collector Plates for Electrostatic Precipitators"<sup>12</sup>. The high resistive, low conductivity bus concept is described in an article entitled "Short-Resistant Two-Stage Electrostatic Precipitator Designs" which appeared in IAS CONFERENCE RECORD, September 1980<sup>13</sup>. Both of these documents are referenced in this report.

---

10. U.S. Patent 4,166,729, op. cit.

11. IAS Conference Record, op. cit.

12. U.S. Patent 4,166,729, op. cit.

13. IAS Conference Record, op. cit.

### Resistive Plate Cell

The concept described in U.S. Patent 4,166,729<sup>14</sup> was applied to the design of the present modular precipitator cell by selecting a special material for the high voltage plates. All other parts and material remained the same.

The preferred characteristics of the special resistive plate material were high electrical resistance, flame retardance and physical properties similar to .025 sheet aluminum. We found one manufacturer, U.S. Samica, whose parent company in Switzerland manufactures such a product. It is a 1/32-inch thick sheet material designated Semiconductive Laminate Vetronite EP-G11 SIB 432.10 with a surface resistivity of 1,000 - 50,000 ohms per square.

The surface resistivity of this material was considered to be too low; however, since this was the highest resistance standard material available, samples were procured. A prototype cell was made using this material for the high voltage plates. When the plates were shorted, the power supply was overloaded and the power supply shut down.

The same vendor later supplied a laboratory sample of the highest resistance material they were capable of manufacturing. This material, designated EP-G11 SIB 432.95 - 39X, has a surface

---

14. U.S. Patent 4,166,729, op. cit.

resistivity of 1 - 50 megohms per square. A sample cell was constructed exactly the same as a standard cell shown in Figure 1 except the high voltage plates were fabricated from this material. This cell was tested and compared with a standard cell. Results are shown in Table 1. This design resulted in a significant improvement over the standard cell; however, higher resistance plates would produce even better results. Because of the limited available material and to be compatible with the NRL test duct, a 6" cell was fabricated in the same manner and tested in comparison to a standard 6" cell. The test results are presented in Table 2. These results support our earlier conclusion that higher resistance material would be desirable. The cell construction is shown in Figure 4. The electrical schematic is shown in Figure 5 where the semiconductive plates are electrically resistive. The 6" cell with semiconductive high voltage plates was delivered to NRL on October 14, 1982 for heavy smoke loading tests.

The 6" collecting cells used in these tests, both the standard design and the modified designs, do not provide the minimum specified collecting efficiency of 90%. The air flow capacity is determined by the gross face area of the cell multiplied by the airflow velocity of 600 feet per minute. The proportion of loss of effective face area, due to the end plates and the top and bottom covers, is greater in the 6" cells than in the standard 10" and 16" cells. The test data is reported only as a comparison of performance of different designs.

The resistive plate cell prototypes exhibited many of the desired characteristics. This design complies with all the requirements of MIL-F-22963B<sup>15</sup> and is suitable for retrofitting in presently installed modular ESP's without modification.

With this design, the energy available for an electrical arc is limited to the energy stored in a single plate capacitor. The incidence of arcing is reduced since a higher voltage gradient is required to induce an electrical arc. Equipment was not available to measure the energy of an arc but the arc was visually observed to be much less severe than in the standard cell.

An electrical short circuit from a high voltage plate to ground affects only the area approximately one inch from the point of short circuit. The remainder of the high voltage plate and all other high voltage plates remain charged. With one or more high voltage plates shorted to ground, the unaffected portion of those plates and all unshorted high voltage plates maintain an equal electrical charge.

Because of the low surface resistivity of the high voltage plate material (1 - 50 megohms per square), each short circuit caused excessive current draw with a corresponding

---

15. Military Specification, op. cit.

decrease in voltage and collecting efficiency. A material with the required surface resistivity (200 - 500 megohms per square) would have only a negligible increase in current draw with each short circuit.

The semiconductive material used for the prototype cells can be fabricated by the same manufacturing methods and tooling as used for the standard design. The manufacturing labor cost for both types of cells will be comparable. However, the semiconductive material costs approximately ten times as much as the present aluminum material.

### Resistive Bus Cell

The concepts described in the NRL paper, "Short-Resistant Two-Stage Electrostatic Precipitator Designs"<sup>16</sup>, were explored as follows:

A cell was fabricated using resistive sleeves over the high voltage bus bars (see Figures 6 and 7). Black phenolic rod was used for the resistive sleeve. The operation of this cell under normal conditions was equivalent to a standard cell. When the high voltage plate next to the end plate was arced to ground or shorted, the resistive sleeve arced across the surface at the ends of the sleeve from the first high voltage plate to the high voltage bus bar. During an arc (momentary short), the high voltage plate drops to zero voltage. All of the voltage developed by the power supply now appears across the resistive sleeve. This produces an arc across the sleeve surface followed by tracking and failure. Refer to Figure 8 for location of the failure.

We then built a cell using resistive bushings over the bus bars (see Figures 9 and 10). First we machined the bushings out of phenolic rod. The cell built from these failed in a manner similar to above except that the arc track occurred along the interface between bushings from the high voltage plate that had been arced or shorted to the high voltage bus bar (see Figure 11).

---

16. IAS Conference Record, op. cit.

We then molded semiconductive spacers from several materials for testing. All spacers made from high resistance material failed in the same manner as already described. The reason for the failure is the nature of the semiconductive material. In all cases, it consisted of conductive particles mixed with and suspended in an insulating material. When voltage is applied to such a material, there is no conduction unless the conductive particles are touching each other or there is arcing or tracking between adjacent particles that do not touch. In the event of arcing or tracking, carbonization occurs and a short circuit results from high voltage plate to bus bar. If there is no arcing or tracking but simply conduction along a string of conductive particles, local overheating occurs because of the high current density in the semiconductive particles. This eventually leads to a short. Adding conductive material in higher concentrations reduces the resistance of the bushing and reduces the isolation of the high voltage plate from the bus bar.

### R-C Spacer Cell

We conceived a better way to couple the high voltage from the power supply to the cell plates. A capacitor was inserted between each high voltage plate and a bus bar connected to the power supply. The high voltage plates were electrically isolated from each other. Each high voltage plate along with the two adjacent grounded plates and the coupling capacitor comprise a capacitive voltage divider.

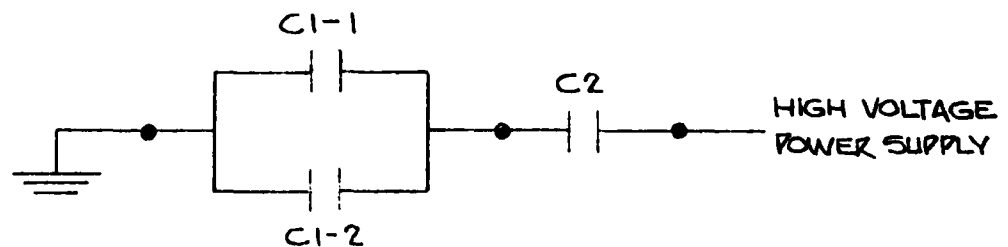

$C_{1-1}$  = Capacitance between HV plate and one adjacent ground plate.

$C_{1-2}$  = Capacitance between HV plate and other adjacent ground plate.

$C_2$  = Coupling capacitor

Combining the capacitance from each HV plate to ground yields this simplified network:

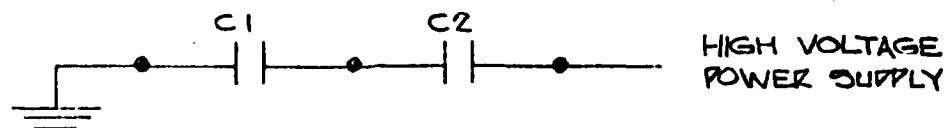

The capacitance from each HV plate to ground is 178 pfd in a standard cell. The voltage applied to this network will charge both capacitors and will divide inversely as the capacitance. In order for most of the applied voltage to be stored in the

capacitance of the collecting plates, the coupling capacitor  $C_2$  must be much larger than  $C_1$ . A test cell was fabricated using 470 pfd capacitors coupling the high voltage power supply to each HV plate. This cell was tested by arcing and shorting the high voltage plates to ground.

When a plate was shorted, the coupling capacitor charged up to the power supply voltage. Other plates were unaffected. When the short was removed, a period of several minutes passed before the charge on the coupling capacitor was transferred to the plates. During this period, the partially charged plate would have been less effective in collecting particulate. In order to overcome this problem, we attempted to obtain a high voltage capacitor with a low insulation resistance so that the attendant high leakage current would facilitate quick recovery of the system. Such a capacitor was not readily available so we elected to place a resistor in parallel with the coupling capacitor to accomplish the same purpose. The value of this resistor had to be very high to prevent current drain on the power supply but low enough to permit reasonably fast recovery after clearing a shorted plate. A 500 megohm resistor gave good results. See Figure 12 for circuit diagram of this R-C Spacer Cell.

We then conceived the idea of molding a high voltage plate spacer with the coupling capacitor and its parallel resistor within the spacer. The spacer would be an insulating material such as epoxy. The components would be embedded in such a way that one

set of leads would contact the cell high voltage bus bar and the other leads would contact a high voltage plate (see Figure 13 for spacer configuration and Figure 14 for plate configuration. Only one high voltage bus bar and one set of spacers molded with a capacitor and resistor inside would be required per cell. The spacers used on the other high voltage plate support rods could be made entirely of an insulating material. See Figure 15 for insulated spacers and Figure 16 for R-C Spacer Cell.

Prototype spacers were fabricated and a sample cell was built to this configuration. Tests showed its performance to be as expected (see Table 3). An invention disclosure (Trion #50)<sup>17</sup> was filed on May 21, 1982 and the Navy was informed of this in a letter to the contracting officer on October 8, 1982.

We contacted several companies known to be manufacturers of high voltage ceramic capacitors to produce spacers. The spacer was to contain a capacitor with low insulation resistance or a capacitor and a separate resistor.

KD Components, Inc. of Santa Ana, California, submitted a proposal to manufacture a ceramic spacer which would consist of a ceramic capacitor with a built-in resistor, molded in the shape

---

17. Trion, Inc. Invention disclosure No. 50 dated May 21, 1982, "Non-Arcing and Short Resistant Collecting Cell".

of a spacer. KD could supply our production needs; however, their lead time for delivery of prototypes was too long for this project.

Cera-Mite Corporation of Grafton, Wisconsin, also submitted a proposal to manufacture a ceramic spacer consisting of a ceramic capacitor with an apparent shunt resistance of several hundred megohms. They estimated their chance of success at less than 50%. They also proposed to build plastic molded spacers with discrete components. They estimated their chances for success with this approach as being very high.

TRW Capacitors Division of Ogallalla, Nebraska, proposed to manufacture plastic molded spacers with discrete components. They furnished samples for testing with estimated costs of \$4.00 to \$6.00 in production quantities. The concept was satisfactory; however, the physical spacing between the contacts was not adequate for the voltage and the samples were not used for the NRL prototypes.

In further work, we conceived of a method to reduce the effect of a short circuit by splitting each high voltage plate in half (see Figure 17). Each half was physically separated from the other and each was coupled to a high voltage bus bar through a molded spacer containing a capacitor and resistor (see Figures 18 and 19). This required two sets of molded spacers with coupling components instead of one but improved the cell performance with

multiple shorts dramatically (see Tables 4 and 5). Now, when a short occurs, only half as much of the cell is disabled as with full size plates. This concept is the subject of Trion Invention Disclosure No. 51<sup>18</sup> filed on November 23, 1982 and submitted to the contracting officer on November 29, 1982.

A prototype of the R-C split plate collecting cell (Figure 18) was shipped to NRL on November 22, 1982 for smoke load testing.

The R-C spacer cell appears capable of meeting all the requirements of the equipment specification<sup>19</sup> and is suitable for retrofitting in the presently installed modular ESP's without modification.

In the R-C spacer cell, the energy available for an electrical arc is limited to that of a single plate capacitor and is further reduced by the coupling capacitor. In the split high voltage plate configuration (Figure 18), the capacitance is further reduced by the reduction in area of the high voltage plate. The incidence of arcing is reduced by the higher voltage gradient required for an arc.

---

18. Trion, Inc. Invention Disclosure No. 51 dated November 23, 1982, "Non-Arcing and Short Resistant Collecting Cell with Split High Voltage Plates".

19. Military Specification, op. cit.

An electrical short circuit from a high voltage plate to ground discharges only the shorted plate while all unshorted plates remain charged. With a short circuit, the coupling capacitor charges to the power supply voltage and prevents additional current flow. The current flow of a short circuit is limited by the resistor to about 13 microamperes which is insignificant in reducing the output voltage of the power supply.

### Semiconductive Materials Testing

A Spacer Test Fixture was designed and fabricated for the purpose of evaluating various materials. It consisted of a collector plate mounted on a stand with a hole in the plate for mounting two semiconductive spacers and a high voltage rod (see Figure 20). Test voltage was applied between the plate and the rod. Each spacer was tested first at 500 VDC with a General Radio Co. Megger, Type 1862A, to establish the resistance between spacer electrodes. The voltage was then raised to collector voltage (6 - 7 KVDC) to determine if the spacer would conduct enough to charge a plate and then withstand the voltage stress during an arc.

Interlocking spacers which mount on a bus bar and support the high voltage plates (see Figure 9) were cast from semiconductive epoxy furnished by Lion Chemical Lab, Inc. of Florence, South Carolina. The resistance measured 400,000 megohms per spacer. This was so high that the material acted like an insulator and would not permit the transfer of an electrical charge from the bus bar to the plate.

We then added Aluminum Bromine to the Lion Chemical Semiconductive Epoxy to reduce the resistance. A quantity of 200 grams of Aluminum Bromine, grade 9B, 250 mesh, was added to 130 grams of epoxy and 10 grams of hardener. This produced a spacer with 100,000 megohms of resistance. This was still too high to permit charging of the plate.

The above procedure was repeated using 400 grams of Aluminum Bromine. All other ingredients remained the same. This time the resistance of the spacer dropped to 375 megohms. This facilitated plate charging but the spacer arced and tracked at 3000 volts when the plate voltage was raised to stimulate a short.

Hysol NB2280-41 semiconductive epoxy was then used to mold a spacer. The resistance was 600 megohms at 500 VDC but the material arced and tracked at 2800 volts when the plate voltage was raised.

This completed our investigation of semiconductive material for spacers. We concluded that a more positive method was needed to facilitate charging the HV plates and resisting the stresses when shorted.

### Summary

The two concepts developed by the Naval Research Laboratory for short resistant ESP collecting cells<sup>20,21</sup> have been investigated. A search was conducted to locate and procure samples of presently available semi-conductive materials that could be adapted to the design concept. Additional semi-conductive materials were compounded. A standard electrical resistance test method was established and test fixtures fabricated for evaluating materials. All potentially usable semiconductive materials that could be obtained during the limited contract period were tested and evaluated.

Because of the electrical failure of all tested materials, an alternate method of a short-resistant collecting cell was devised to eliminate the cause of material failure using presently available materials.

Prototype collecting cells of two different short-resistant design concepts have been made. Both prototypes have been tested and compared to the performance of the present design collecting cell.

Both the resistive plate cell and the R-C Network Spacer cell appear capable of meeting all the requirements of the present

---

20. Ibid.

21. U.S. Patent 4,166,179, op. cit.

equipment specification<sup>22</sup>. Both designs can be installed in the existing modular ESP's with no other modifications to the presently installed equipment. Both designs appear to be capable of operation under conditions of heavy smoke loading for a sufficient period to cleanse a submarine atmosphere of smoke after a shipboard fire.

Collecting efficiency test results for all tested cell designs are shown in Tables 2 through 4 and compared in Table 5. All designs showed reduced efficiency with successive induced short circuits. However, the cause of reduced efficiency is different for each cell design.

In the standard collecting cell design, a short circuit from any high voltage plate to ground directly shorts all high voltage plates. The power supply overloads and the output high voltage reduces to zero. All the high voltage plates become grounded plates to collect the charged particles but there are no high voltage plates to form the electrostatic field to force the charged particles to the grounded plates.

In the resistive plate cell, a short circuit discharges only the immediate area of the short. Except for the small area of the short, the electrostatic field remains for the particle

---

22. Military Specification, op. cit.

collection process. However, because of the low resistance of the resistive plate material, the short circuit draws excessive current. The increased current reduces the output voltage of the power supply thereby reducing the force of the electrostatic field for particle collection.

In the R-C spacer cell, a short circuit discharges the shorted plate and destroys the electrostatic field between that plate and the two adjacent grounded plates. Because of the limited current draw of the short circuit, the electrostatic field around all other plates remains essentially the same.

Prototypes of both designs have been submitted to the Naval Research Laboratory for heavy smoke load testing. The results of the NRL tests will provide guidance for further development efforts.

All objectives of the contract have been fulfilled within the allocated time.

### Recommended Future Efforts

The prototypes of the resistive plate design and the R-C network spacer design have both demonstrated the capability of meeting all the performance requirements of MIL-F-22963B<sup>23</sup> under normal operating conditions. Both designs are adaptable to retrofitting in presently installed modular ESP's with no other modifications to the presently installed equipment.

When tested under heavy smoke loading conditions, it is expected that both prototypes will demonstrate the ability to remain operational and remove smoke from the air stream for a sufficient period to cleanse the submarine atmosphere of smoke after a fire.

The objective of the present contract<sup>24</sup> -- to demonstrate the feasibility of short resistant ESP collecting cells -- has been successfully completed. However, the limited time and resources available under the present contract did not afford the opportunity for a complete investigation of available semiconductive materials or alternate methods of applying the R-C network to the collecting cell design.

The prototypes submitted for testing are intended as functional prototypes to test the feasibility of the design concept. Neither prototype is a final design suitable for economical

---

23. Ibid.

24. Naval Research, op. cit.

production. We expect that both prototypes, when subjected to heavy smoke loading, will eventually overload and fail.

From the NRL smoke testing, we want to determine the effect of the accumulation of smoke particles on the surface of the resistive high voltage plates. We also want to determine the effect of the accumulation of smoke particles on the insulated spacers in the R-C spacer cell.

The semi-conductive material used for the high voltage plate in the resistive plate cell prototype did not have sufficient electrical resistance to prevent excess current draw from a short circuit. However, it did exhibit the desired characteristic of limiting the area of electrical discharge to the immediate area of the short circuit. The cost of the resistive plate material is approximately ten times the cost of the aluminum plate material. Additional efforts are required to identify or fabricate a more suitable resistive plate material.

The R-C network concept can be applied to the resistive bus cell design by using components other than the resistor and capacitor in the present prototype. Further efforts are required to determine the ultimate configuration of the R-C network plate spacer and an economical method of fabricating the spacer.

Efforts should be expended to combine the concepts of the resistive plate cell and the resistive bus cell to utilize the most desirable features of both concepts.

All efforts to date have been devoted to increasing the operational life of the ESP collecting cell. The collecting cell is the major aerosol collector in the life support system but it is only one part of the system that could fail under heavy smoke loading conditions.

The present ESP power pack has separate high voltage circuits for the ionizing and collecting sections of the ESP. An overload or short circuit condition in the collector circuit will not affect the ionizer circuit. Our tests under this contract have shown that with the collector circuit de-energized and only the ionizer operating, the ESP is still about 25 - 30% effective in removing smoke. In our tests, the particles charged in the ionizer section were collected on the grounded portion of the ionizer, the high voltage and ground collector plates and the walls of the test duct. In a typical ventilation system, it is assumed that additional charged particle collection will occur on the cooling coil fins and other grounded surfaces in the system.

Some of the smoke particles will collect on the ionizing wires. The accumulation will eventually increase the diameter of the wires causing a gradual decrease in particle charging and collecting efficiency. The effects of smoke accumulation on

ionizing wires should be studied and, if necessary, a method to prevent or retard accumulation must be devised.

All ventilation systems have standard navy air filters. The filters are ineffective in collecting smoke but the collecting efficiency and the air flow resistance increase with accumulated contaminant. It is suspected that the air filters may accumulate sufficient particulate to block the passage of air through the ventilation system under conditions of heavy smoke loading.

Future efforts should include smoke testing of a simulated typical ventilation system. Required for the testing is a smoke generation chamber with a test duct and fan to recirculate the air. The test duct should include standard navy air filters, a multiple cell ESP and a typical cooling coil.

TABLE 1

Resistive Plate Cell Efficiency

Specifications: 10" Collector - 18 High Voltage Plates  
Air Velocity - 600 fpm  
Cell Face Area - 0.64 sq. ft.  
Air Flow Capacity at 600 fpm - 385 cfm  
Test Air Flow - 390 cfm  
Test Method - DOP with NRL E-3 Penetration Meter  
Ionizer Power - 13.0 KV/0.8mA

Test Results:

	<u>Standard Cell</u>		<u>Resistive Plate Cell</u>	
	<u>KV/MA</u>	<u>Efficiency</u>	<u>KV/MA</u>	<u>Efficiency</u>
No plate shorted	6.4/0.09	97%	6.5/0.12	97%
1 plate shorted	0/0.19	36%	5.4/1.30	93%
2 plates shorted			4.0/2.20	90%
3 plates shorted			3.0/2.80	83%
6 plates shorted			2.6/2.60	79%
9 plates shorted			2.2/2.40	70%
13 plates shorted			1.5/2.20	59%
18 plates shorted			1.2/2.00	51%
No power on collector cell	0/0	35%	0/0	33%

TABLE 2

Resistive Plate Cell Efficiency

Specifications: 6" Collector - 9 High Voltage Plates  
Air Velocity - 600 fpm  
Cell Face Area - .394 sq. ft.  
Air Flow Capacity at 600 fpm - 234 cfm  
Test Air Flow - 240 cfm  
Test Method - DOP with NRL E-3 Penetration  
Ionizer Power - 13.0 KV/0.5mA

Test Results:

	<u>Standard Cell</u>		<u>Resistive Plate Cell</u>	
	<u>KVDC/mA</u>	<u>Efficiency</u>	<u>KVDC/mA</u>	<u>Efficiency</u>
No plates shorted	6.6/0.14	86%	6.6/0.16	85%
1 plate shorted	0/1.65	29%	5.4/1.10	84%
2 plates shorted			4.6/2.75	83%
3 plates shorted			4.2/2.80	82%
6 plates shorted			2.9/2.50	67%
9 plates shorted			2.0/2.60	60%
No power on collector	0/0	28%	0/0	27%

TABLE 3

R-C Spacer Cell Efficiency

Specifications: 6" Collector - 9 High Voltage Plates  
Air Velocity - 600 fpm  
Cell Face Area - .394 sq. ft.  
Air Flow Capacity at 600 fpm - 234 cfm  
Test Air Flow - 240 cfm  
Test Method - DOP with NRL E-3 Penetration Meter  
Ionizer Power - 13.0 KV/0.5mA

Test Results:

	<u>Standard Cell</u>		<u>R-C Spacer Cell</u>	
	<u>KV/MA</u>	<u>Efficiency</u>	<u>KV/MA</u>	<u>Efficiency</u>
No plates shorted	6.6/0.14	86%	6.6/0.33	84%
1 plate shorted	0/1.65	29%	6.6/0.34	76%
2 plates shorted			6.6/0.35	66%
3 plates shorted			6.5/0.36	65%
6 plates shorted			6.5/0.40	50%
9 plates shorted			6.5/0.43	27%
No power on collector	0/0	28%	0/0	29%

TABLE 4

R-C Spacer Split Plate Cell

Specifications: 6" Collector - 9 High Voltage Plates  
Air Velocity - 600 fpm  
Cell Face Area - .394 sq. ft.  
Air Flow Capacity at 600 fpm - 234 cfm  
Test Air Flow - 240 cfm  
Test Method - DOP with NRL E-3 Penetration Meter  
Ionizer Power - 13.0 KV/0.5mA

Test Results:

	<u>Standard Cell</u>		<u>R-C Spacer with Split Plate Cell</u>	
	<u>KV/MA</u>	<u>Efficiency</u>	<u>KV/MA</u>	<u>Efficiency</u>
No plates shorted	6.6/0.14	86%	6.6/0.28	85%
1 plate shorted	0/1.65	29%	6.6/0.30	83%
2 plates shorted			6.6/0.32	83%
3 plates shorted			6.6/0.33	82%
6 plates shorted			6.5/0.36	78%
9 plates shorted			6.5/0.42	74%
No power on collector	0/0	28%	0/0	30%

TABLE 5

Collecting Cell Efficiency Comparison

Specifications: 6" Collector - 9 High Voltage Plates  
Air Velocity - 600 fpm  
Cell Face Area - .394 sq. ft.  
Air Flow Capacity at 600 fpm - 234 cfm  
Test Air Flow - 240 cfm  
Test Method - DOP with NRL E-3 Penetration Meter  
Ionizer Power - 13.0 KV/0.5mA

Test Results:

	<u>Standard Cell</u>	<u>Resistive Plate Cell</u>	<u>R-C Spacer Cell</u>	<u>R-C Spacer Split Plate Cell</u>
No plates shorted	86%	85%	84%	85%
1 plate shorted	29%	84%	76%	83%
2 plates shorted		83%	66%	83%
3 plates shorted		82%	65%	82%
6 plates shorted		67%	50%	78%
9 plates shorted		60%	27%	74%
No power on collector	28%	27%	29%	30%

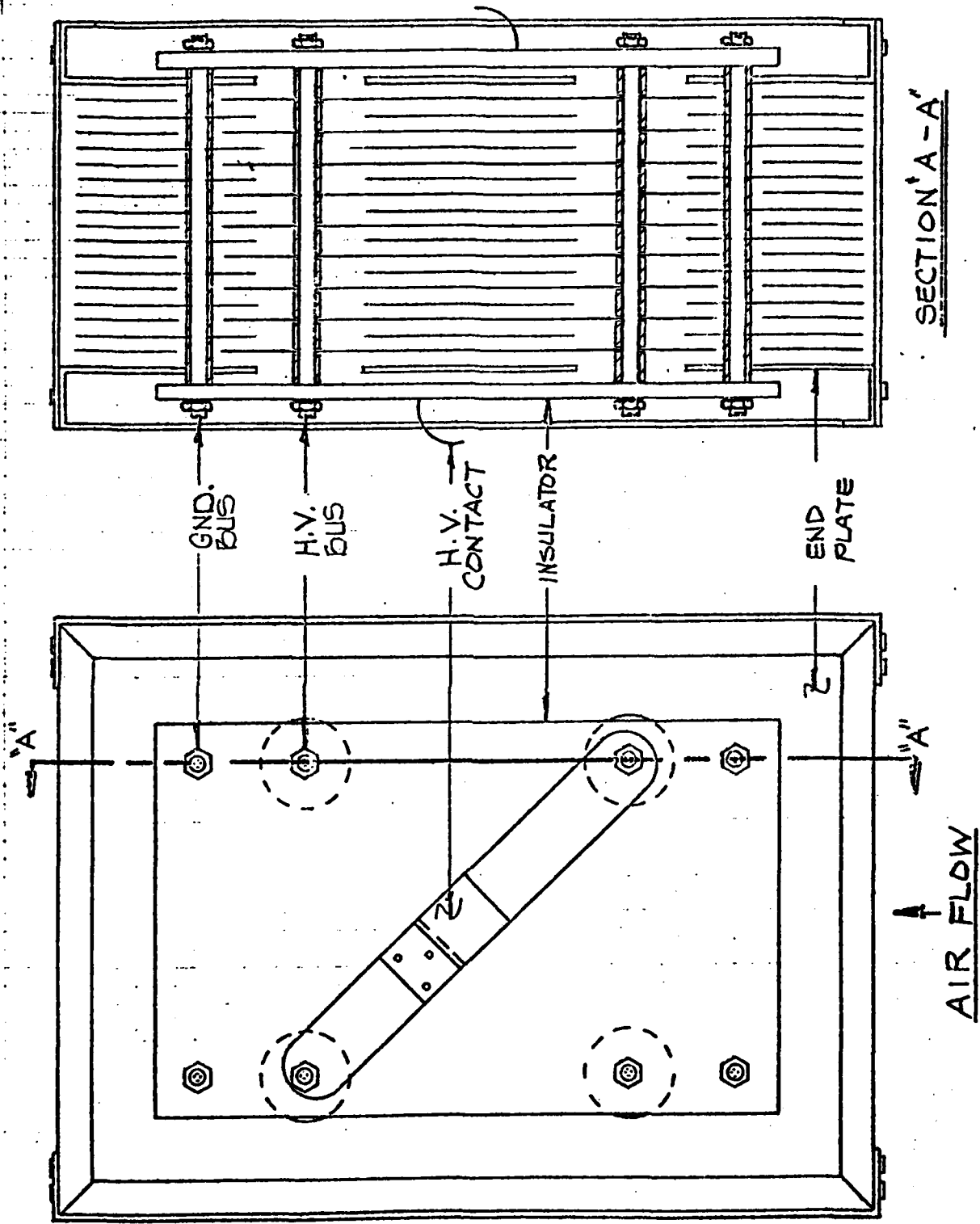

STANDARD  
COLLECTING CELL

FIG. 1

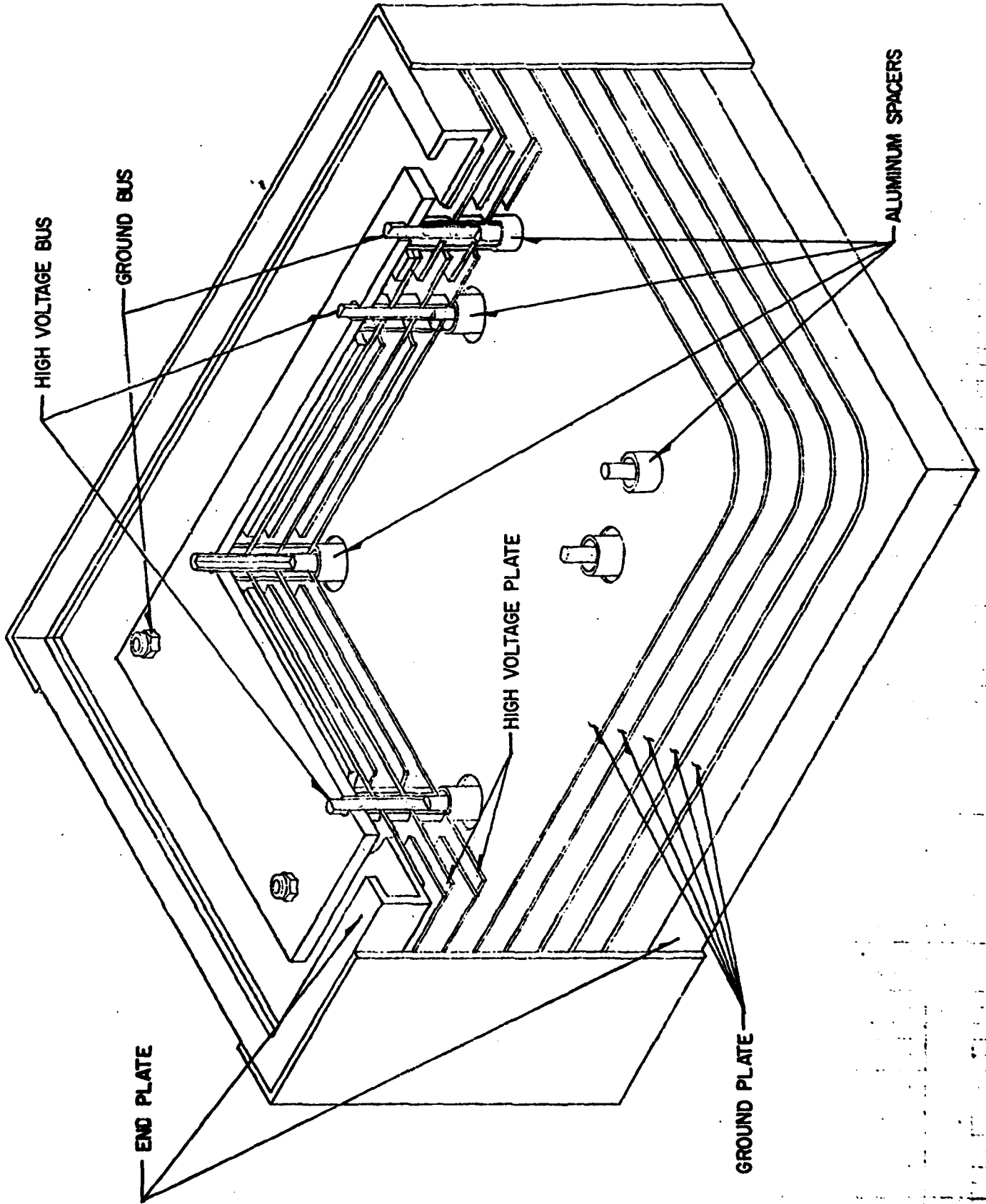

STANDARD CELL

FIG. 2

+HV

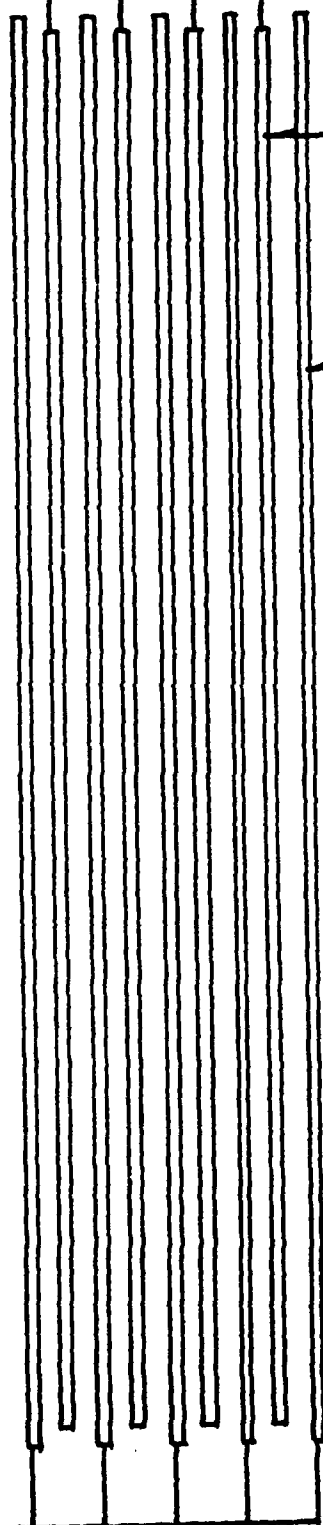

HIGH-VOLTAGE PLATE

GROUND PLATE

STANDARD CELL  
SCHEMATIC

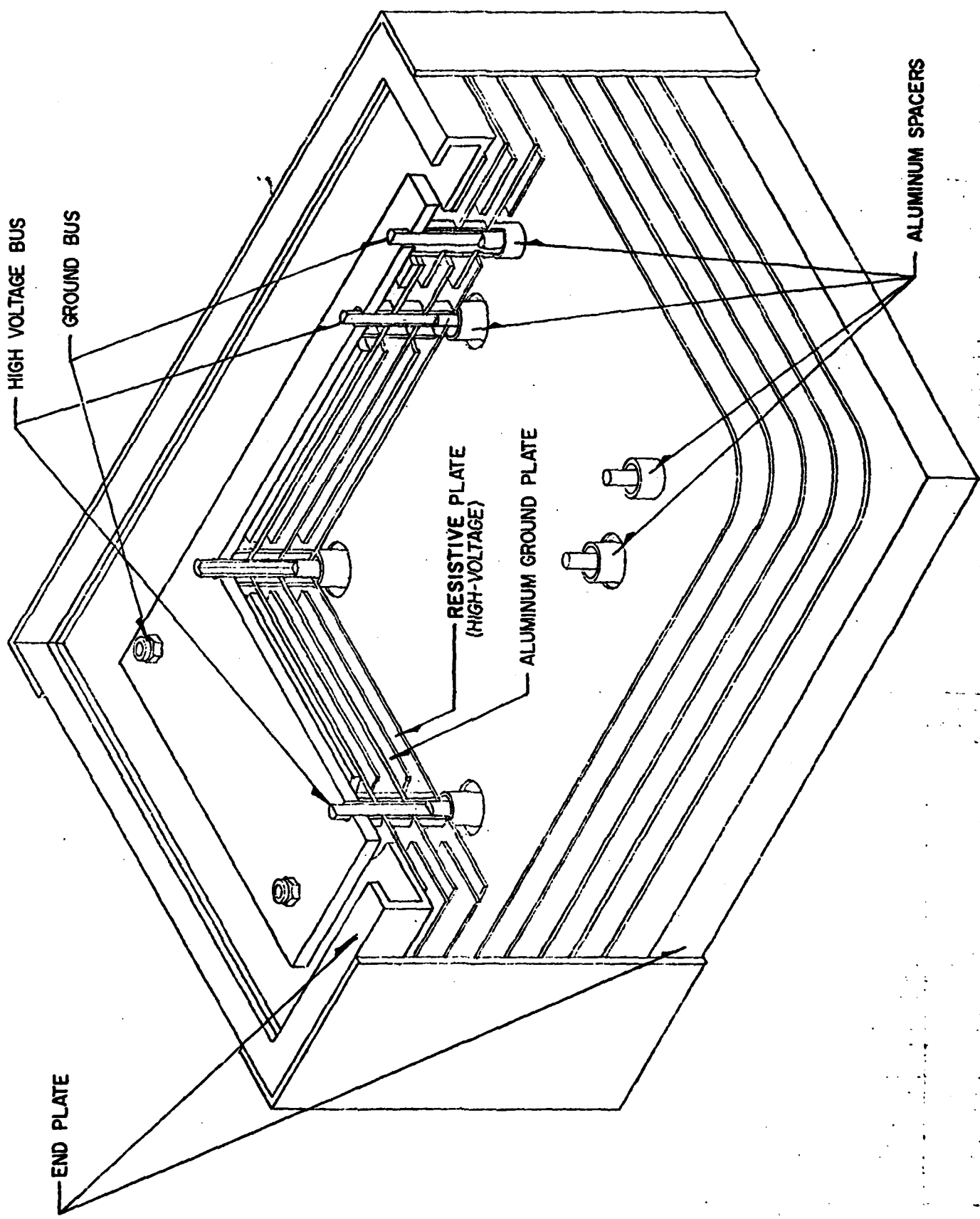

RESISTIVE PLATE.  
CELL CUTAWAY

FIG. 4-

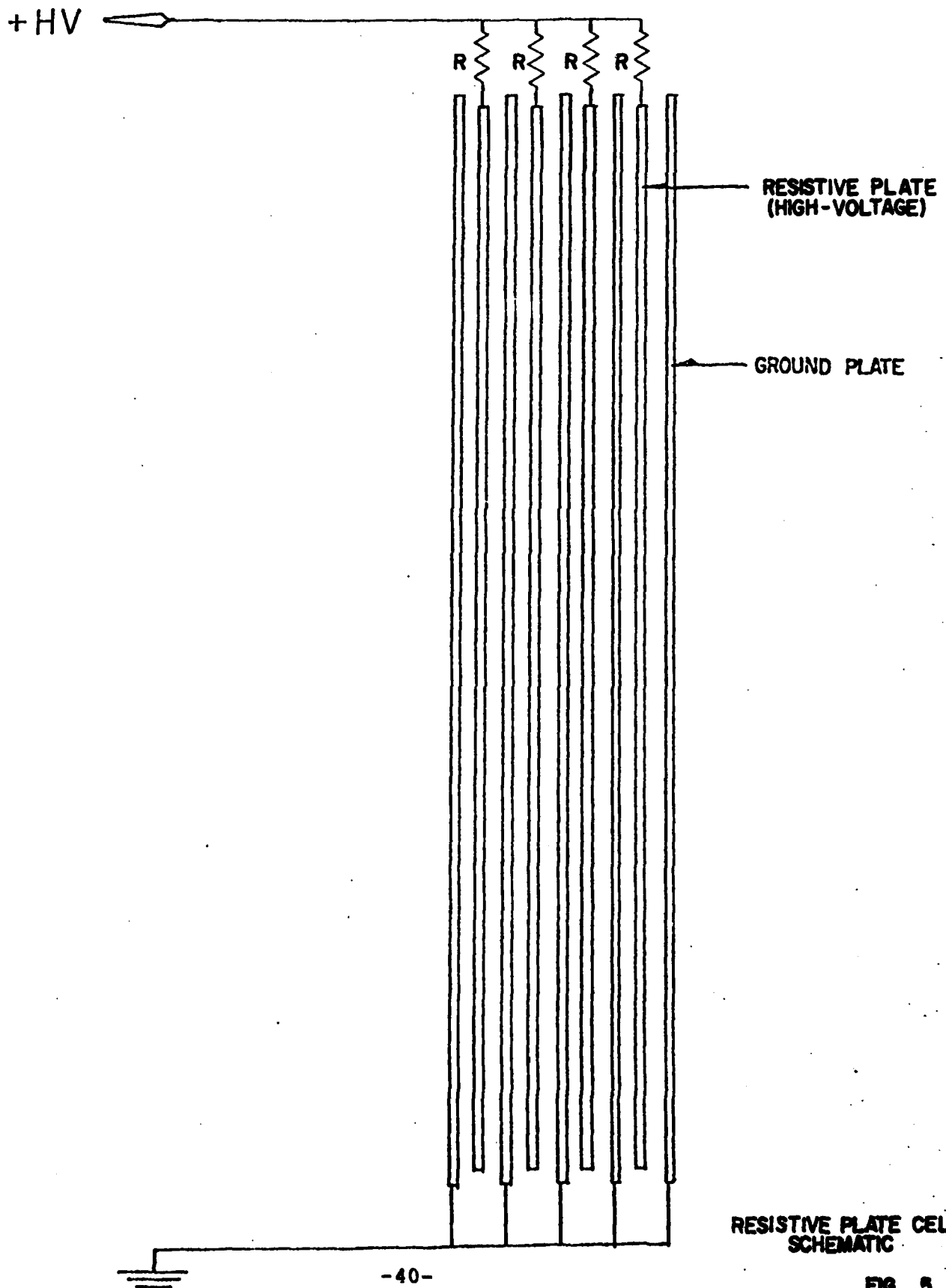

RESISTIVE PLATE CELL  
SCHEMATIC

FIG. 5

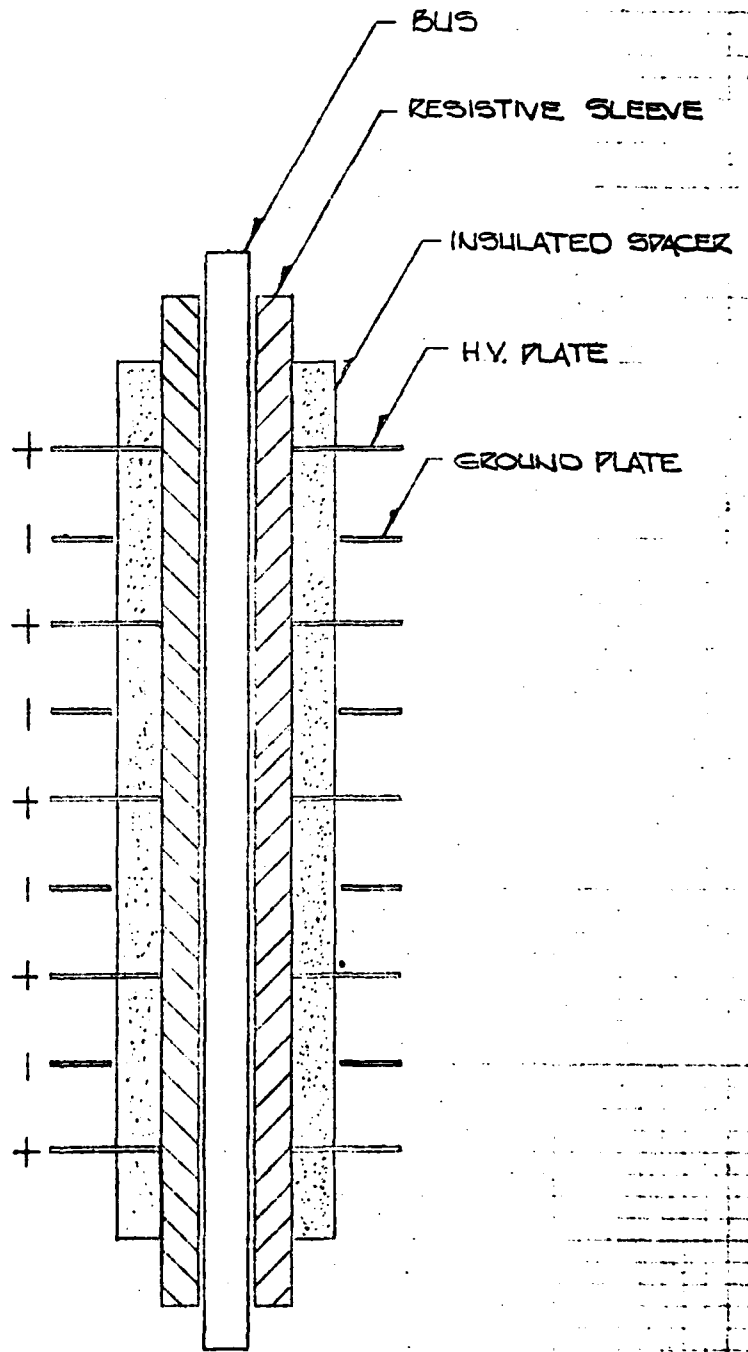

RESISTIVE SLEEVE  
DETAIL

FIG. 6

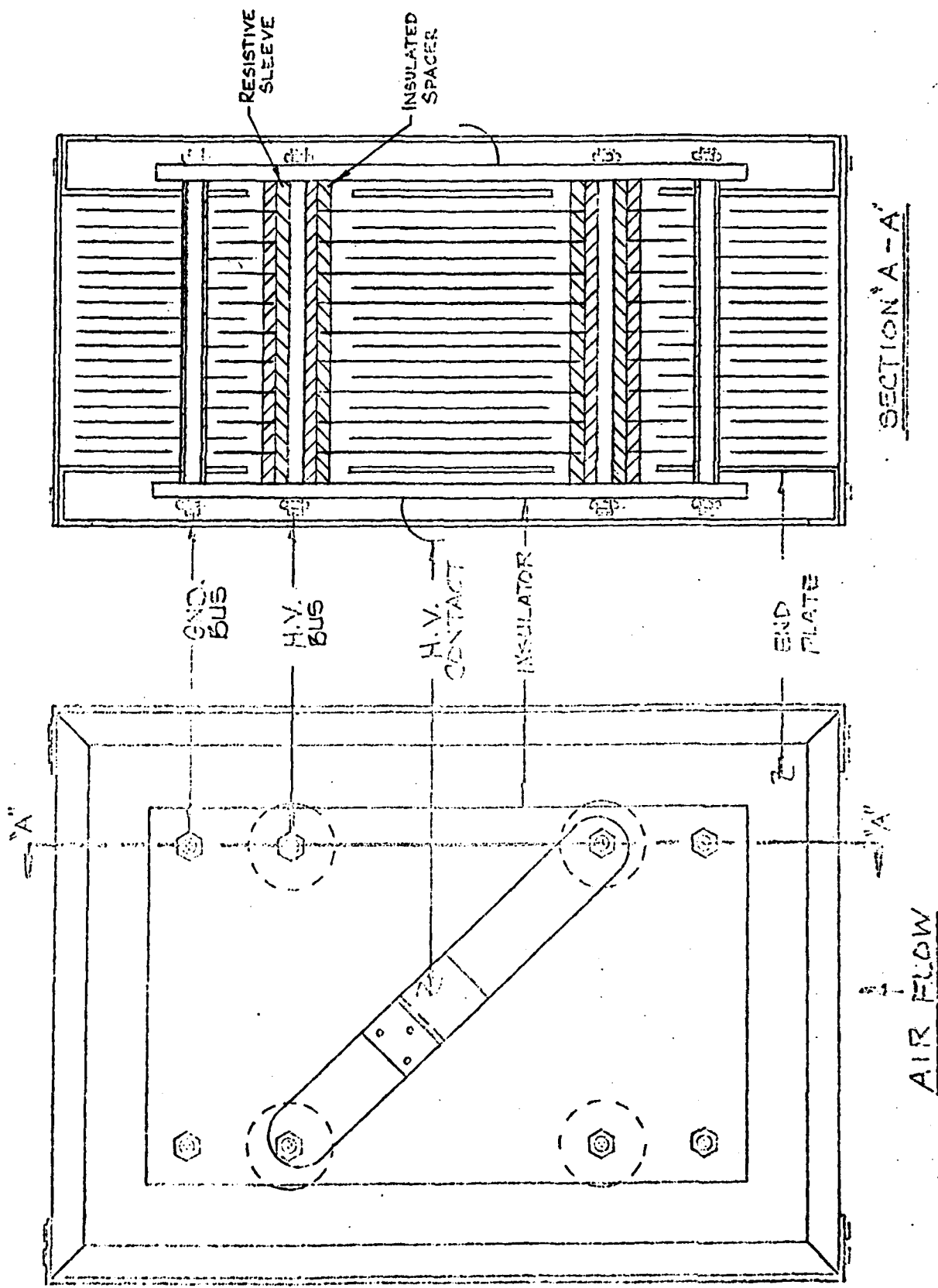

RESISTIVE SLEEVE CELL

FIG. 7

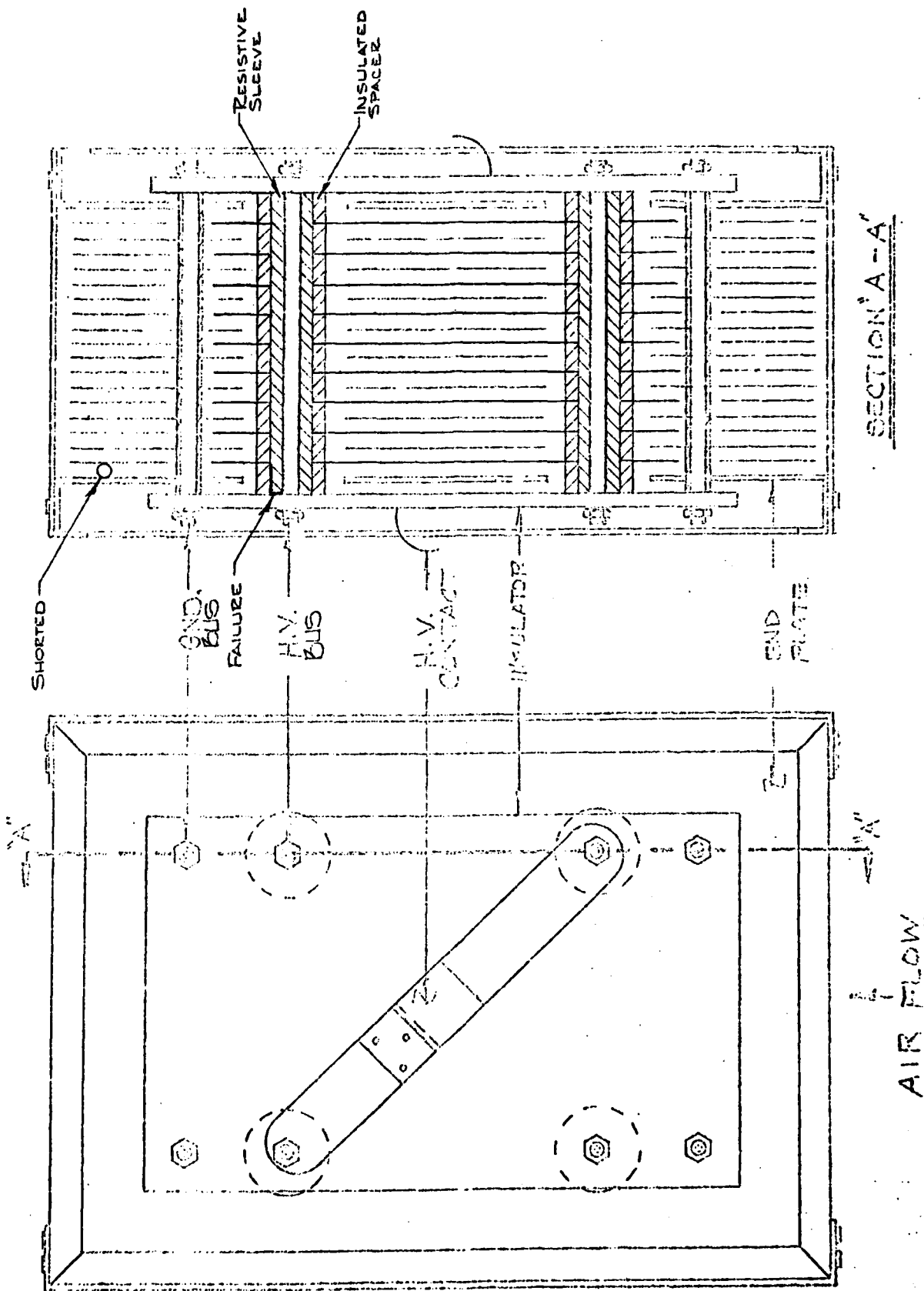

RESISTIVE SLEEVE  
CELL WITH FAULT

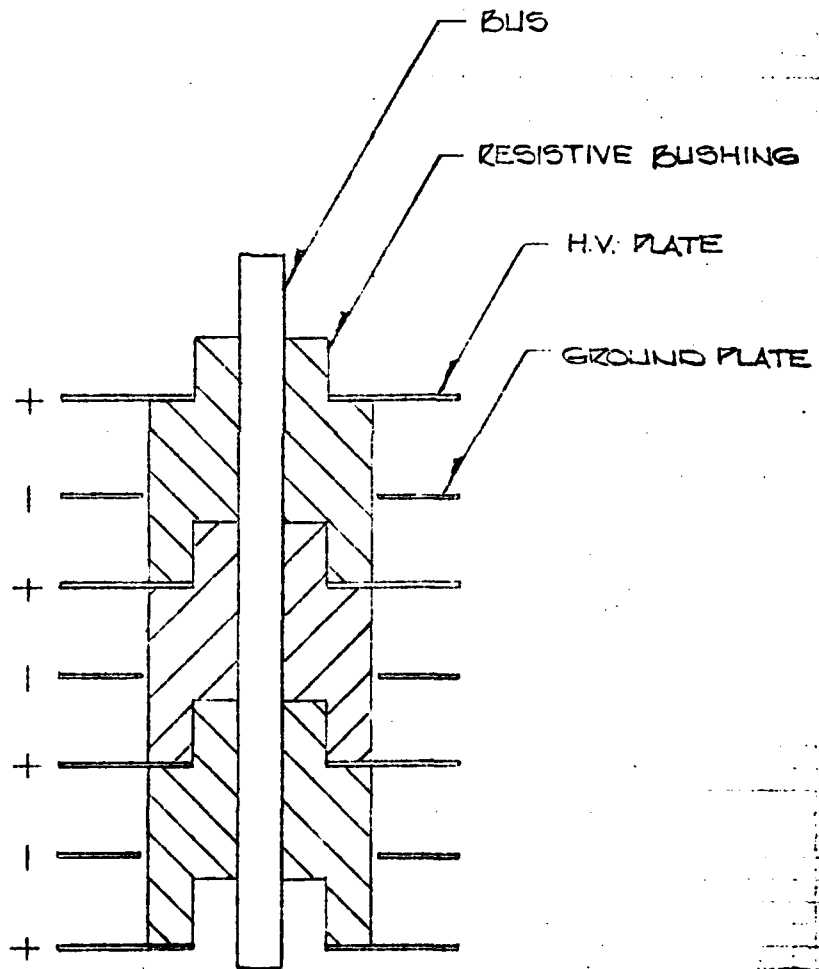

**RESISTIVE BUSHING  
DETAIL**

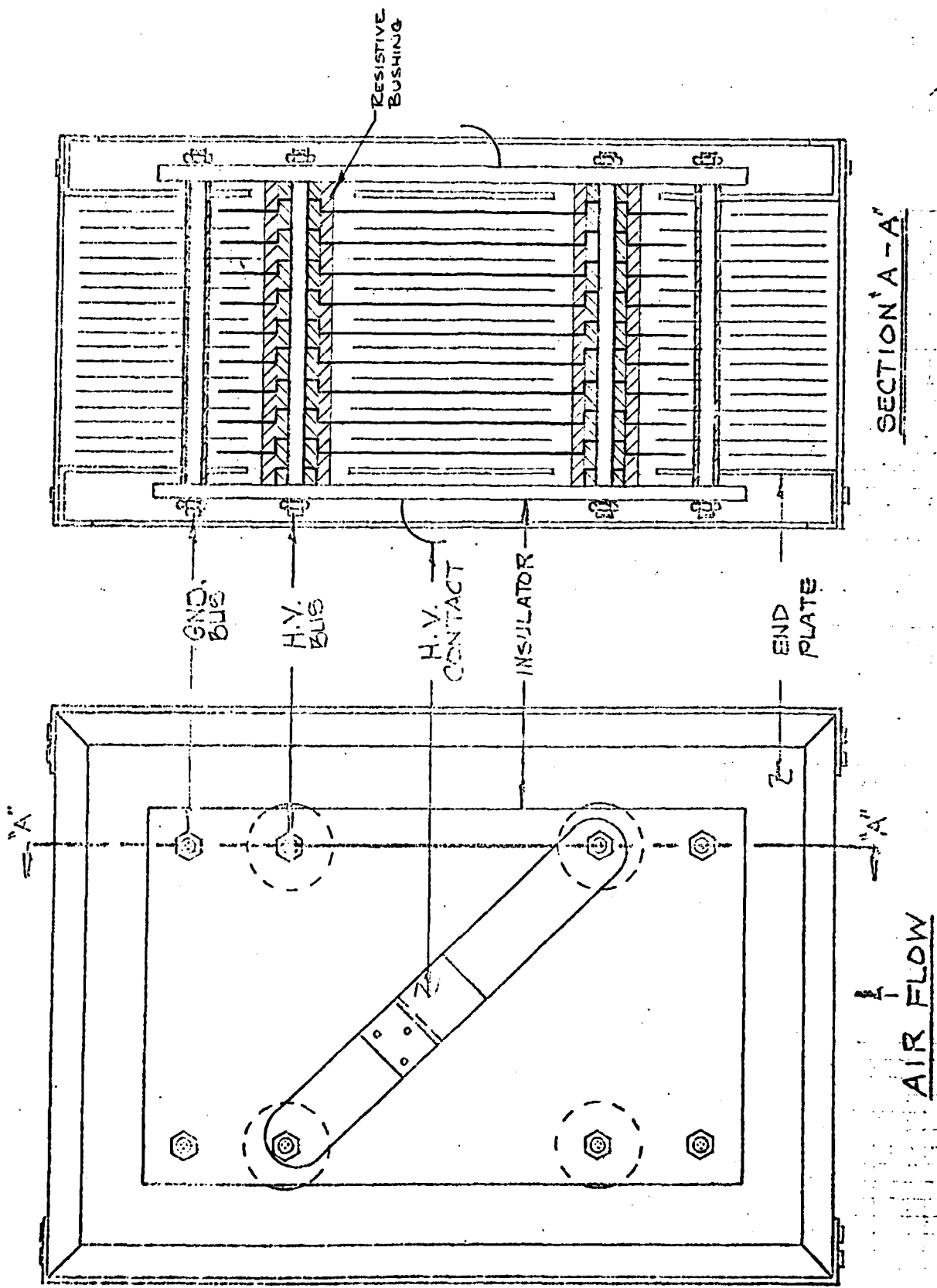

RESISTIVE BUSHING CELL

FIG. 10

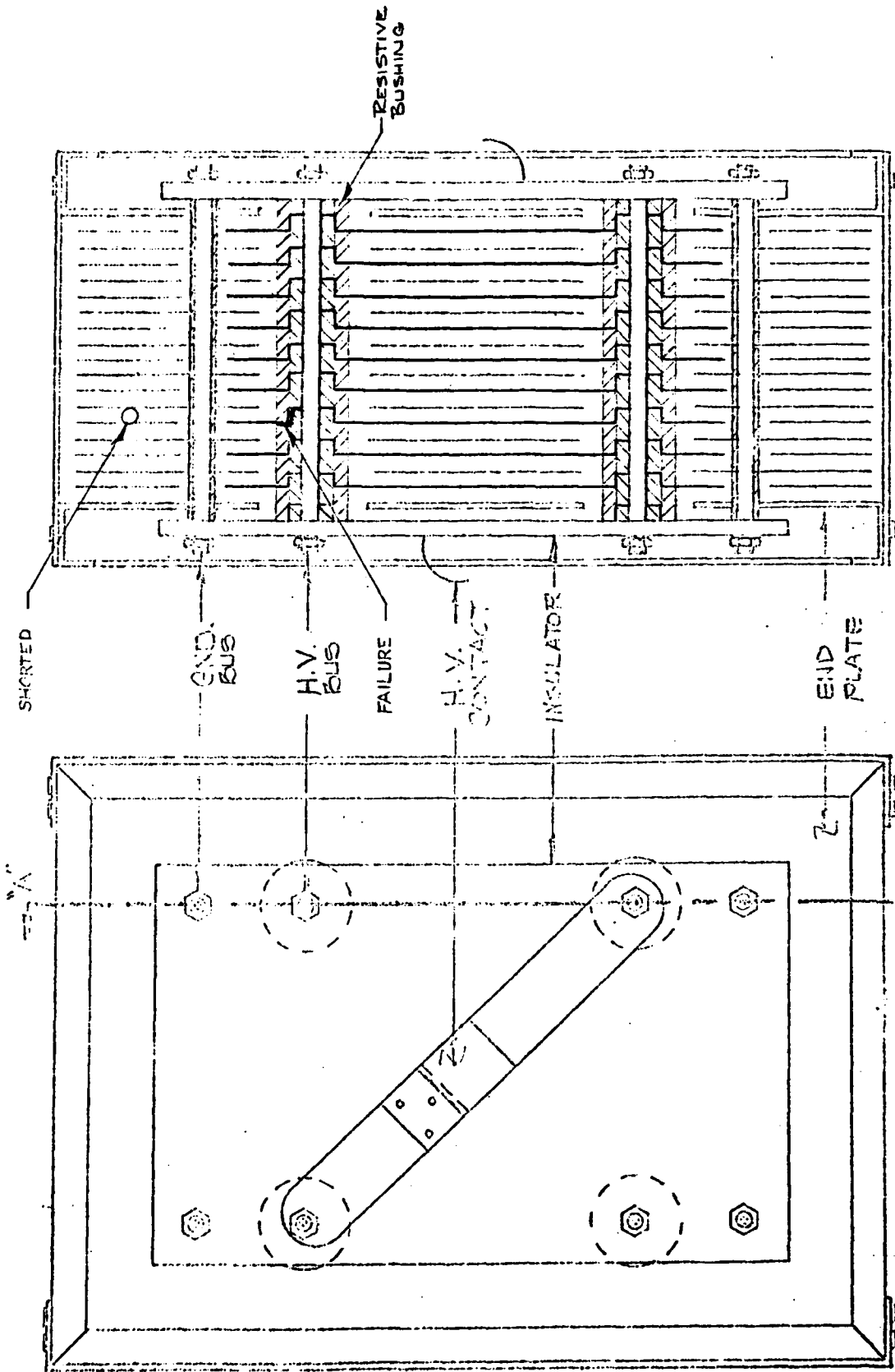

SECTION 'A-A'

AIR FLOW

RESISTIVE BUSHING CELL WITH FAULT

FIG. 11

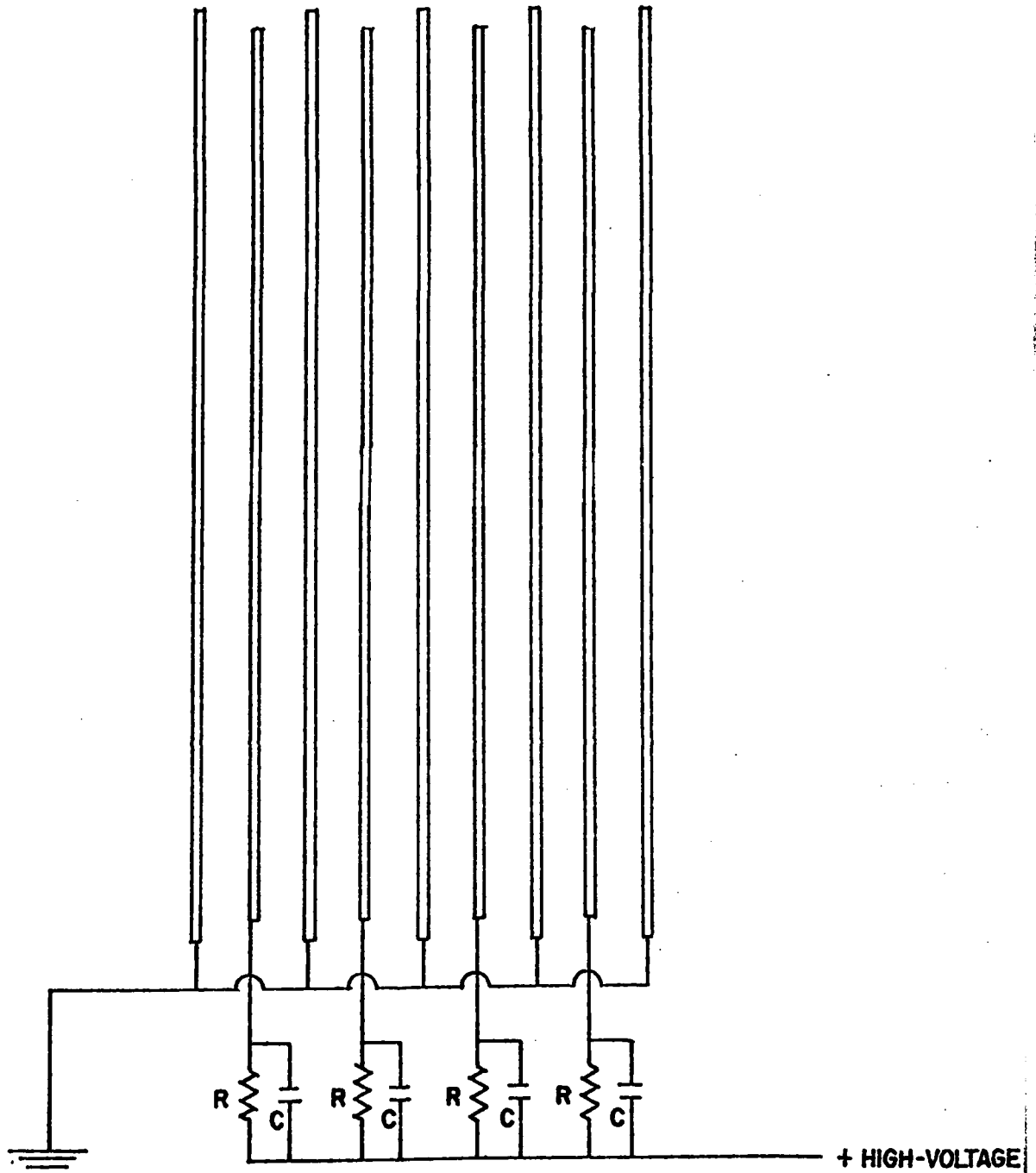

R-C SPACER CELL SCHEMATIC

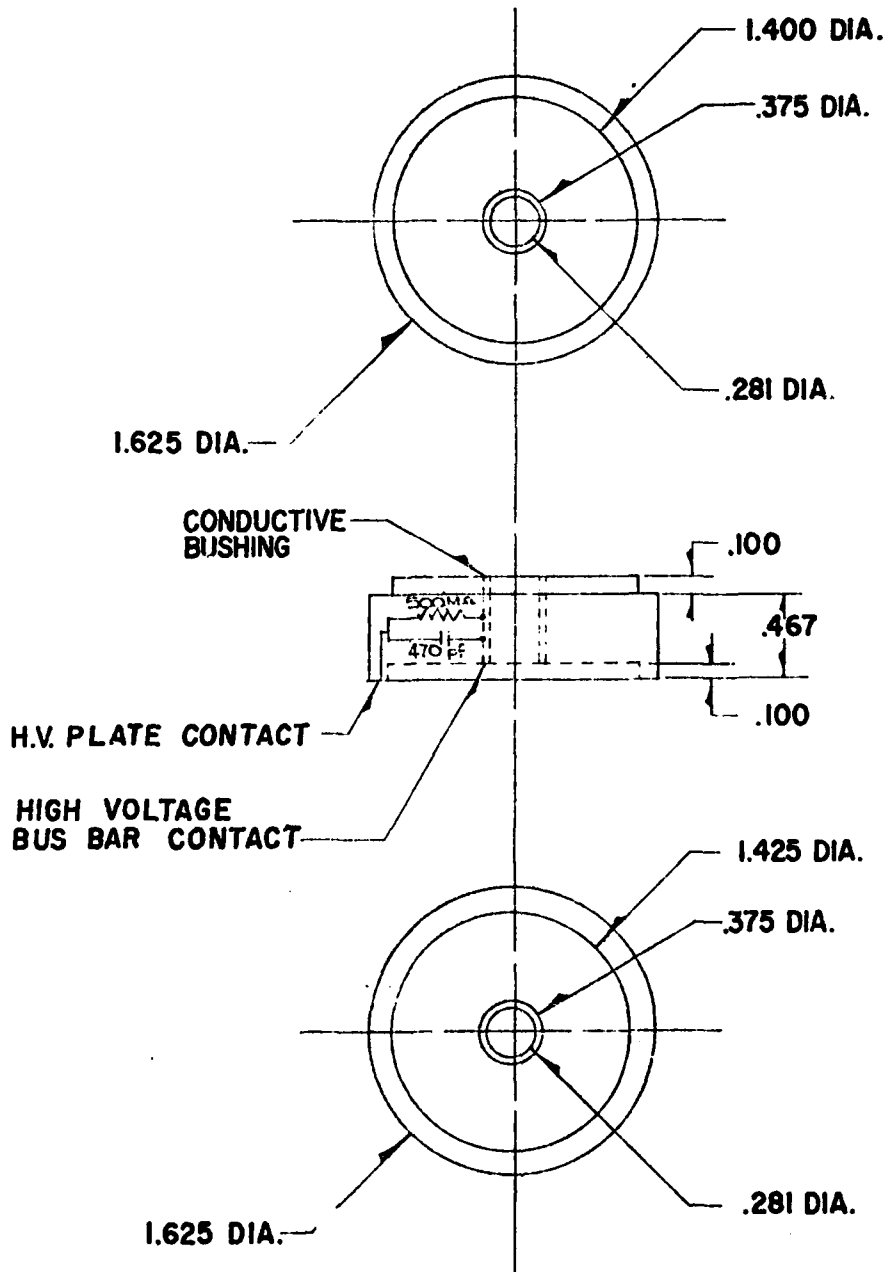

GROUND PLATE

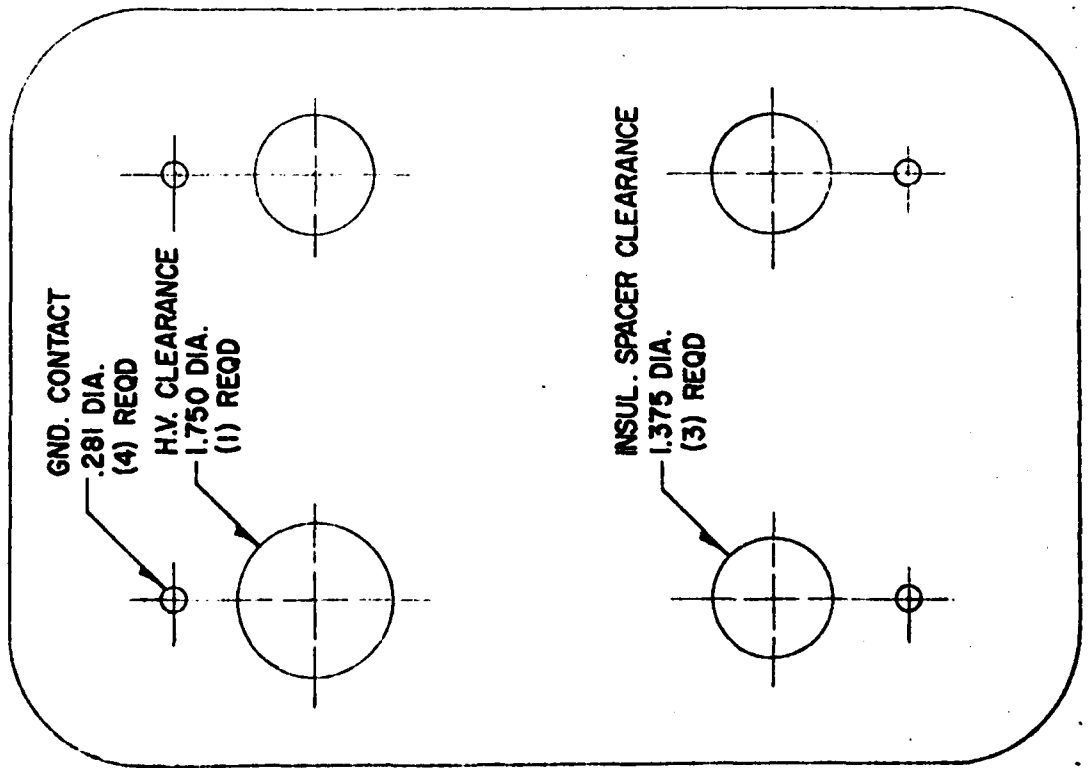

HIGH-VOLTAGE PLATE

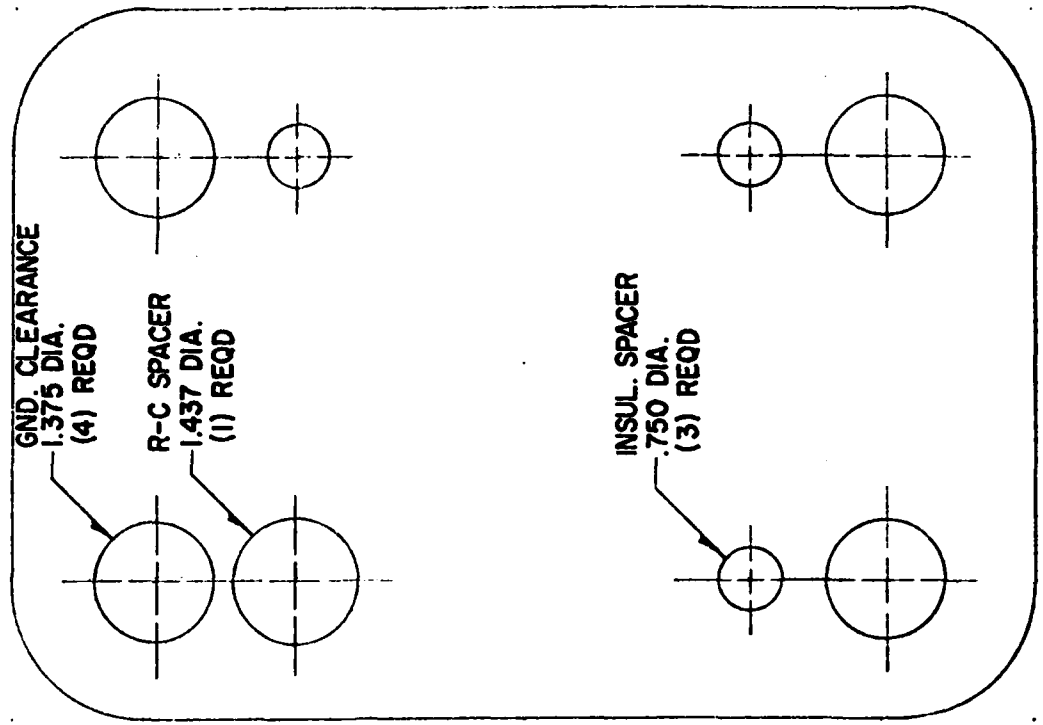

R-C SPACER  
CELL PLATE  
CONFIGURATION

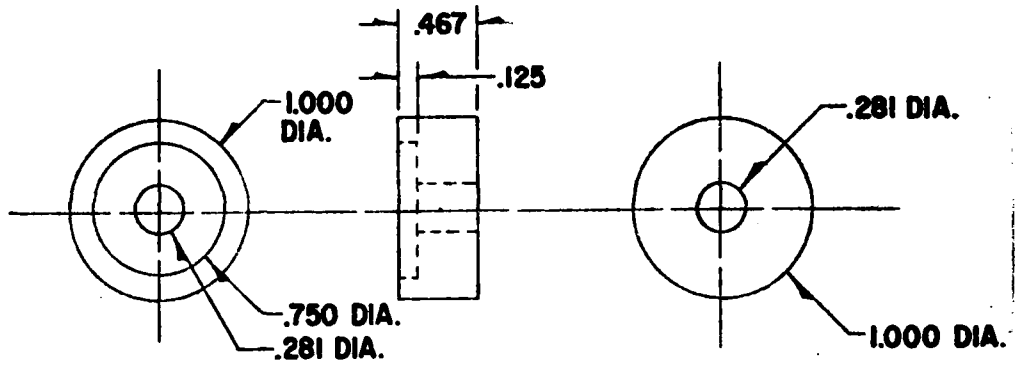
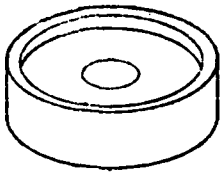

START SPACER

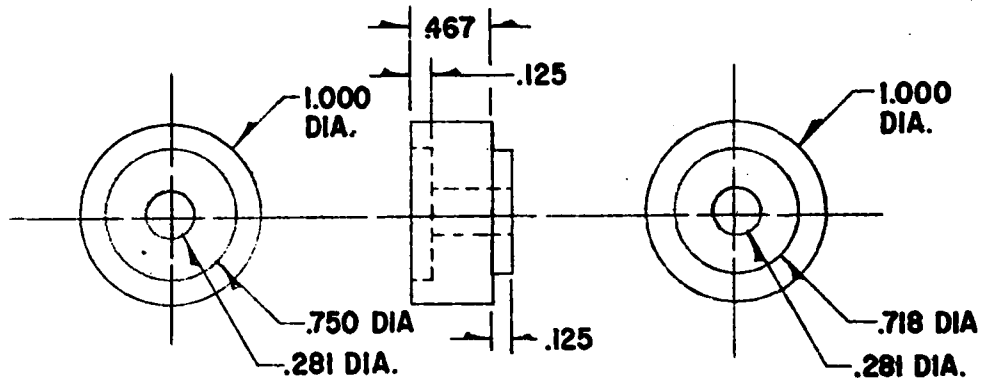
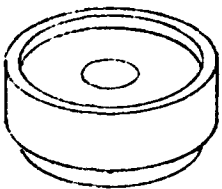

INTERMEDIATE SPACER

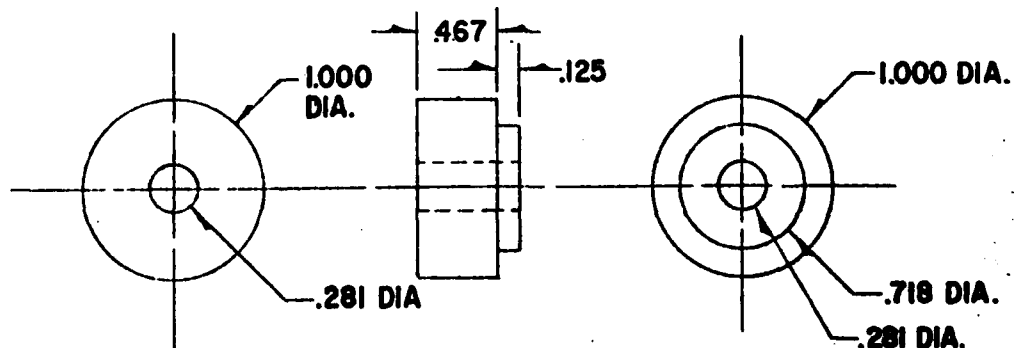
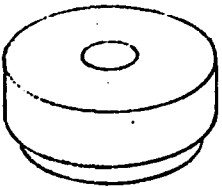

END SPACER

INSULATED SPACER

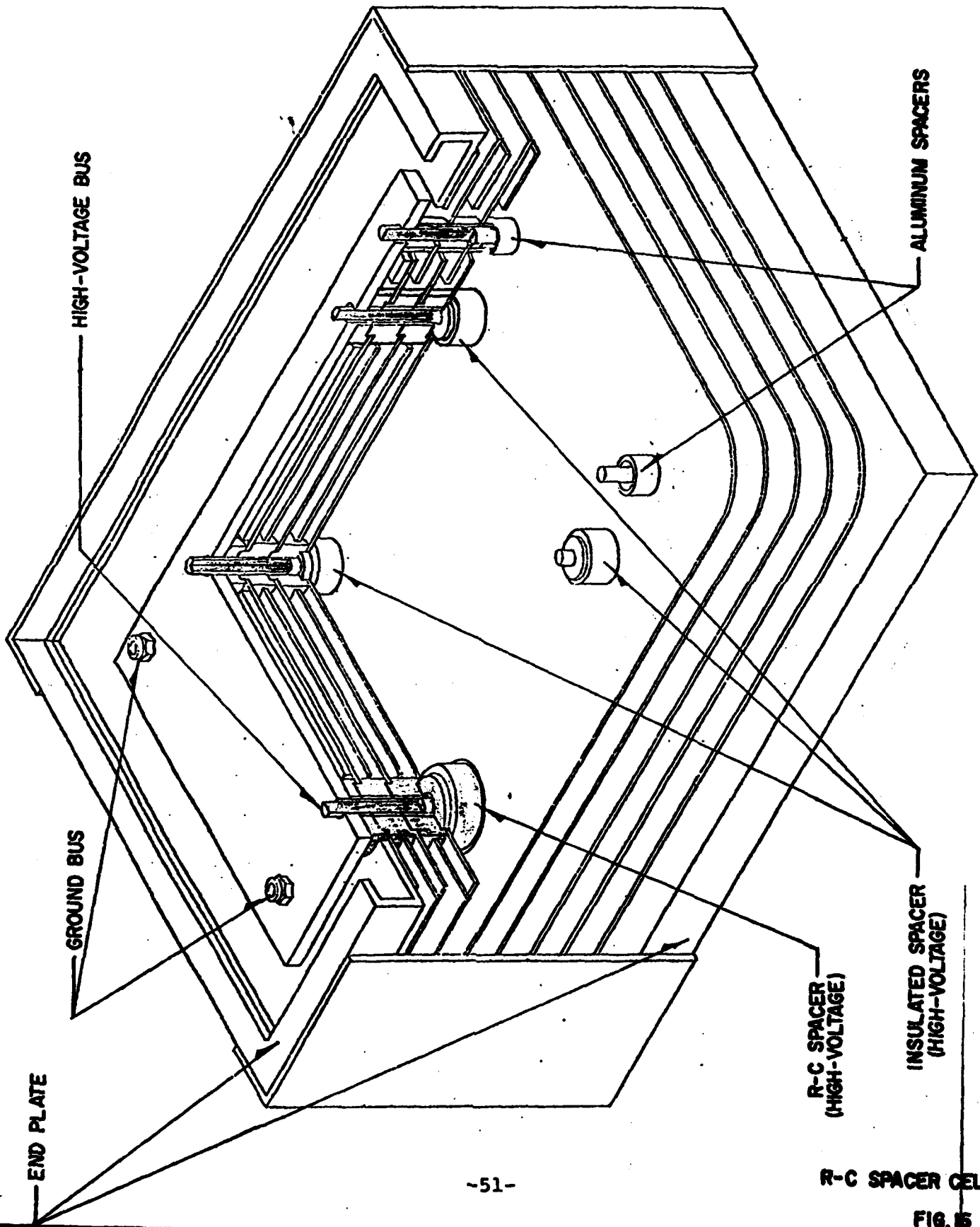

END PLATE

GROUND BUS

HIGH-VOLTAGE BUS

ALUMINUM SPACERS

R-C SPACER  
(HIGH-VOLTAGE)

INSULATED SPACER  
(HIGH-VOLTAGE)

R-C SPACER CELL

FIG. 15

GROUND PLATE

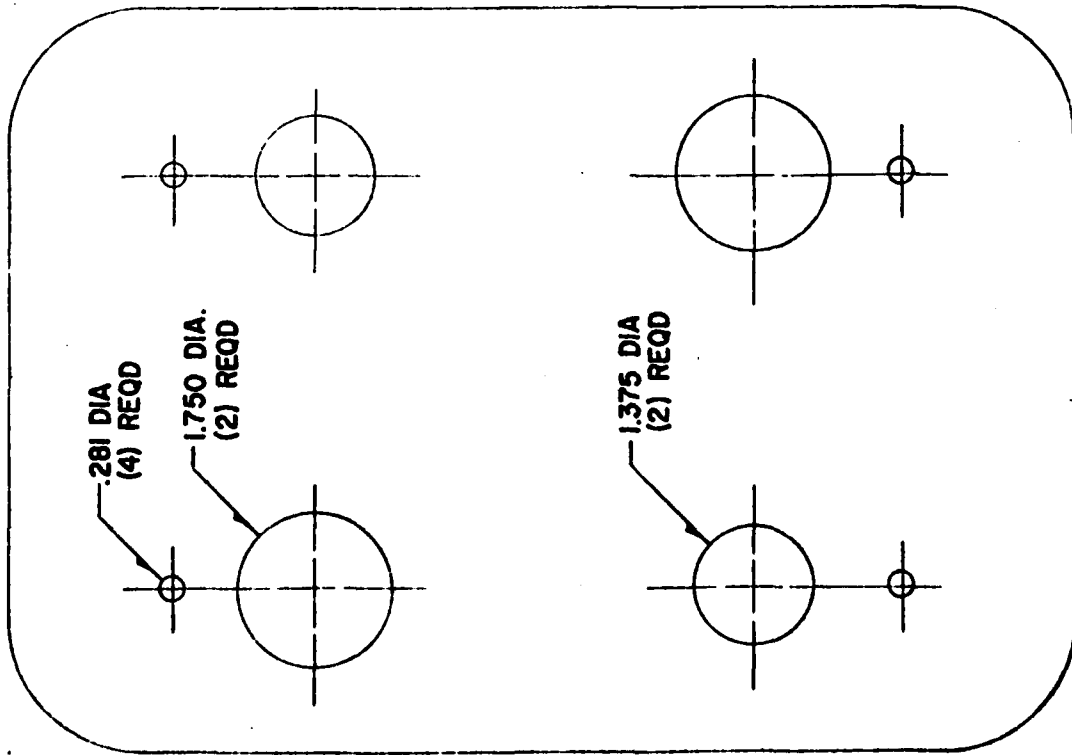

HIGH-VOLTAGE PLATE

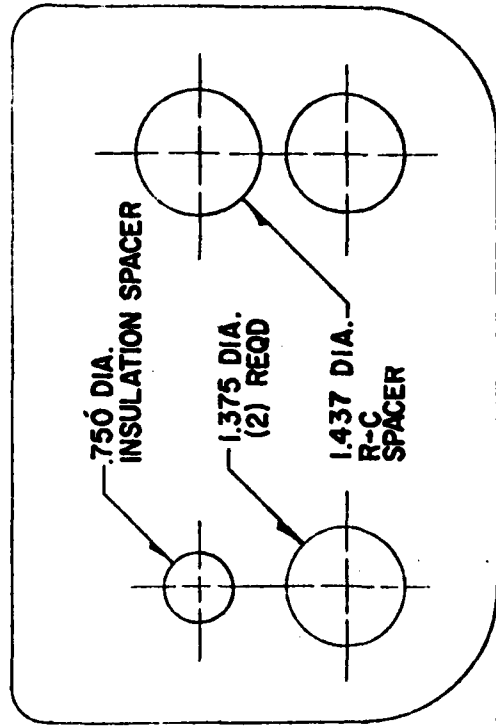
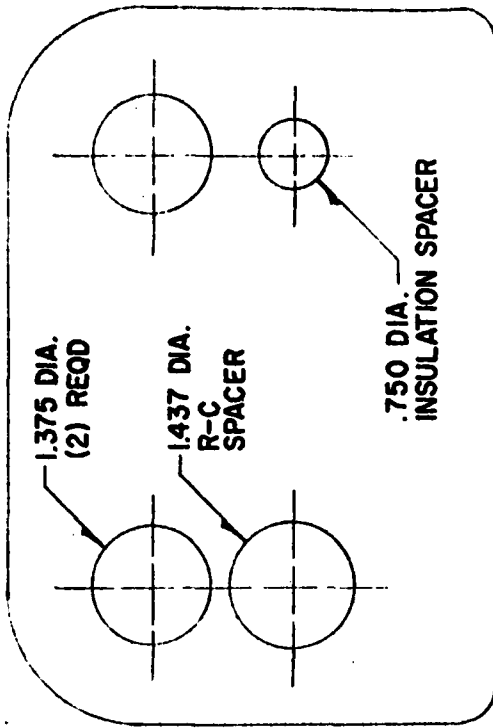

**SPLIT PLATE  
CONFIGURATION**

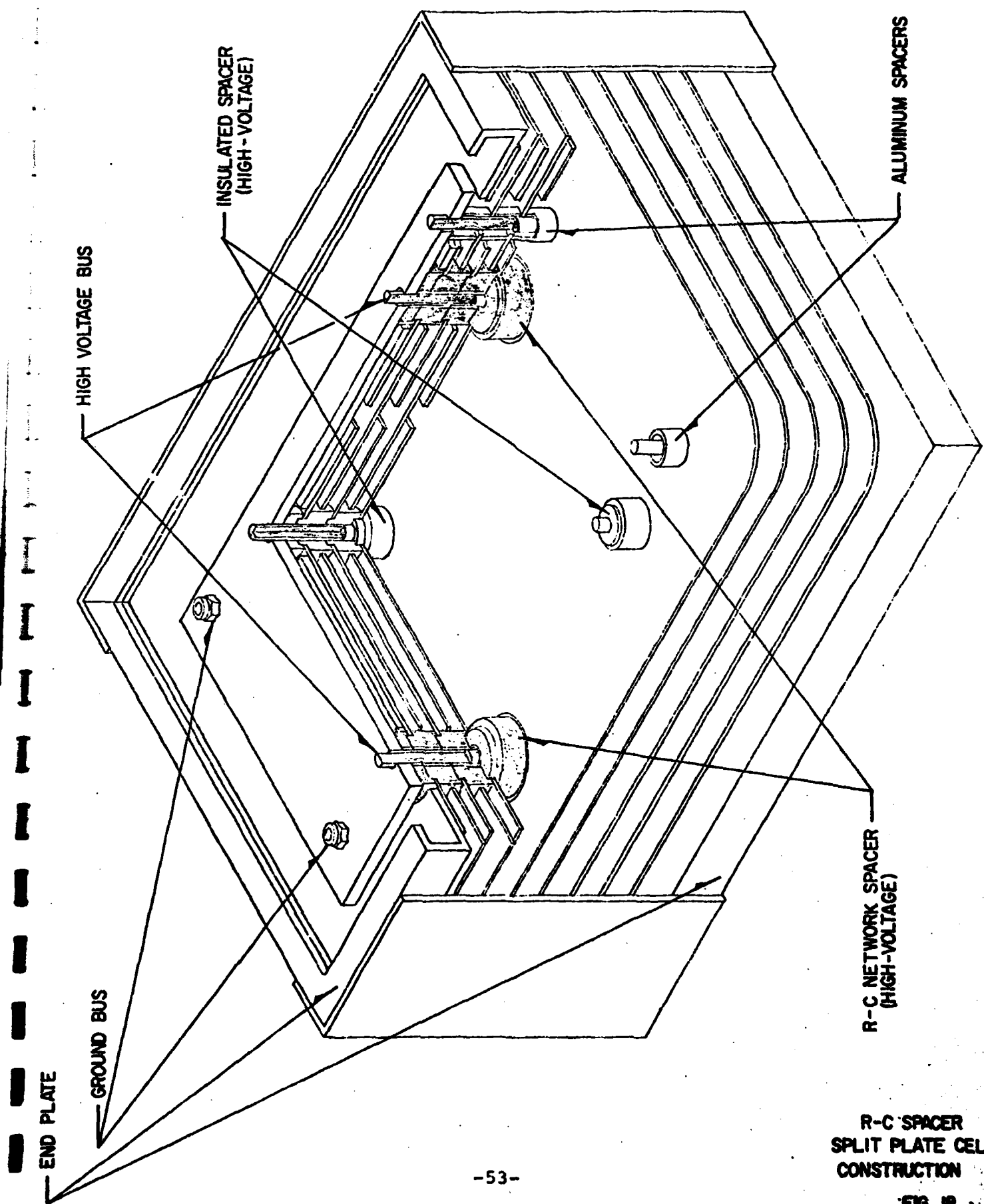

END PLATE

GROUND BUS

HIGH VOLTAGE BUS

INSULATED SPACER  
(HIGH-VOLTAGE)

ALUMINUM SPACERS

R-C NETWORK SPACER  
(HIGH-VOLTAGE)

R-C SPACER  
SPLIT PLATE CELL  
CONSTRUCTION

FIG. 18

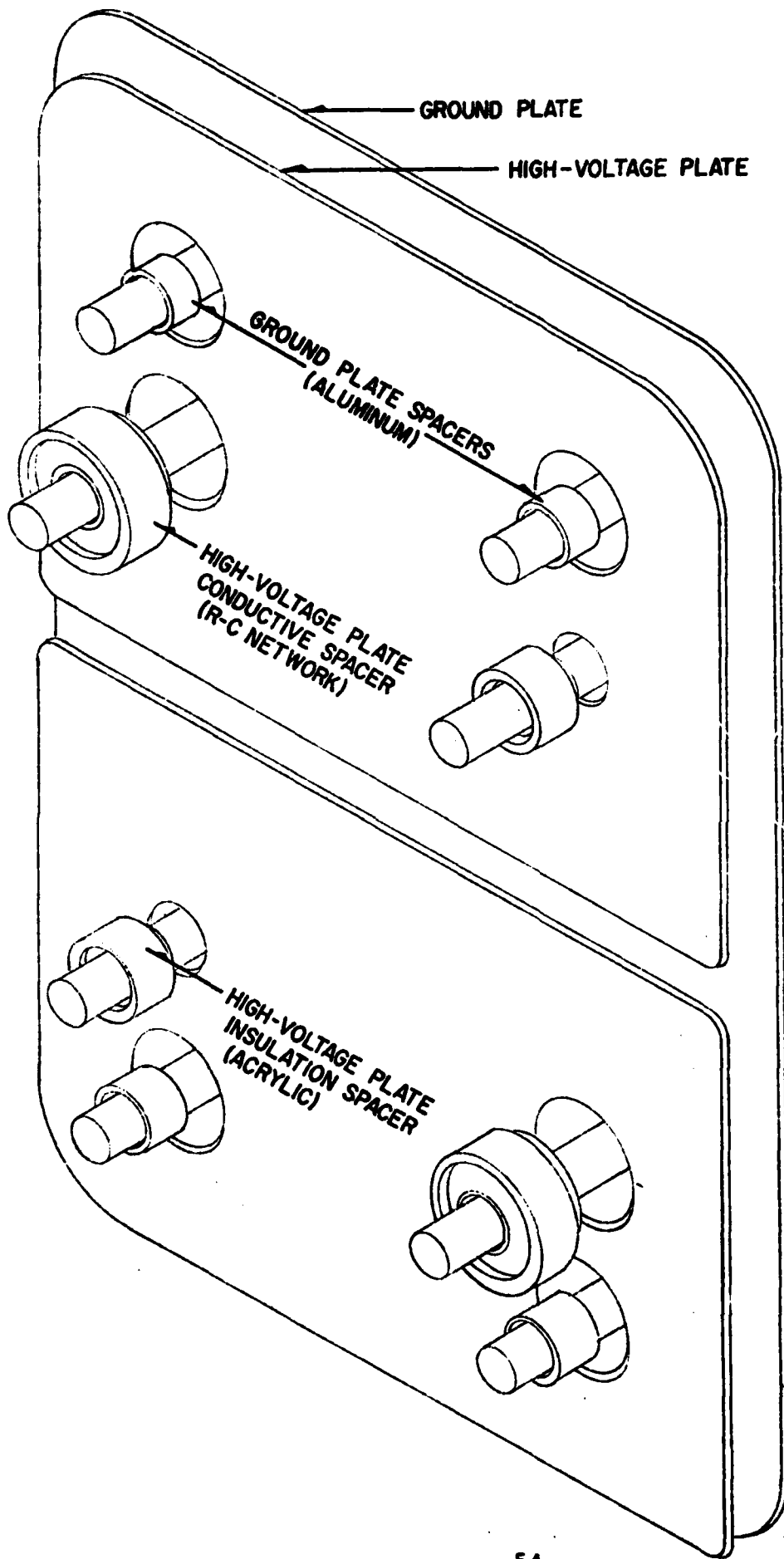

R-C SPACER  
SPLIT PLATE CELL  
DETAIL

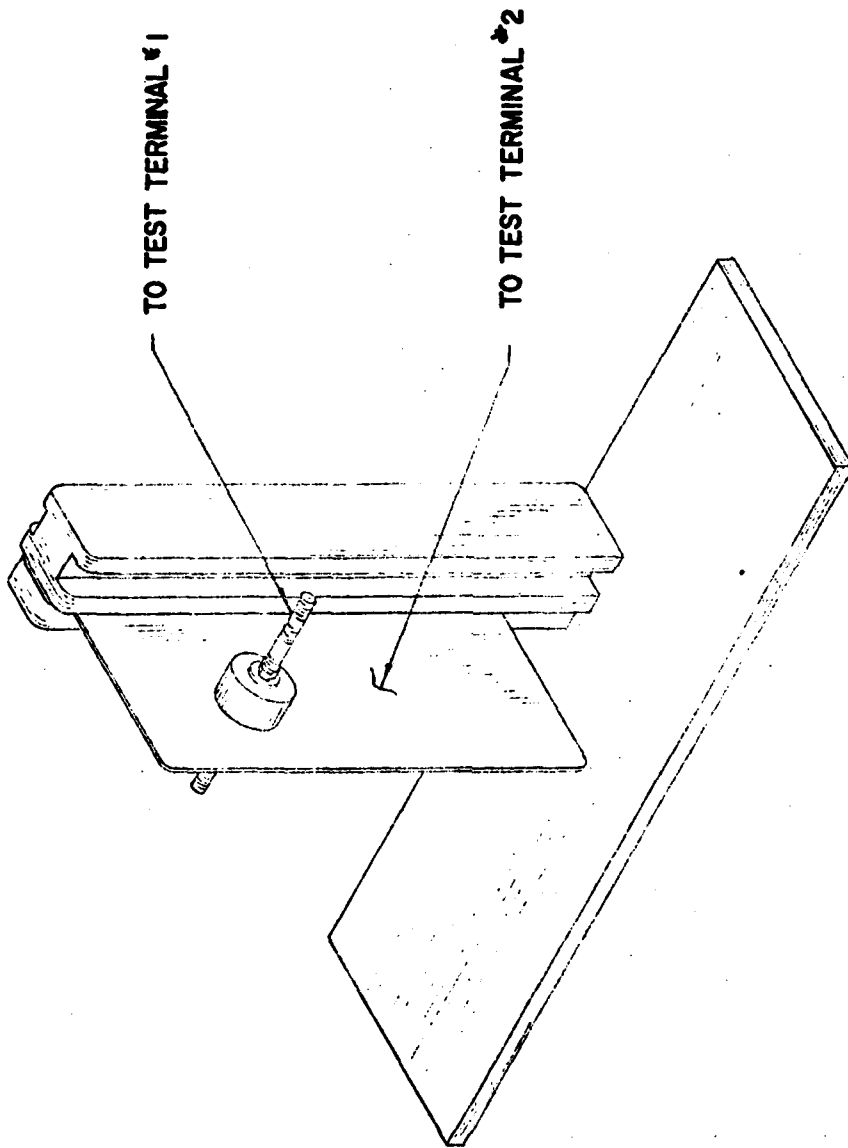

TESTING FIXTURE FOR SPACER

TESTING FIXTURE  
FOR SPACER

**MED**  
**8**