

AD-A122 972

INVESTIGATION OF DISCREPANCIES IN MEASUREMENTS MADE
WITH A 'MINILAB' WBGT INDEX METER(U) AERONAUTICAL
RESEARCH LABS MELBOURNE (AUSTRALIA) A ROSS SEP 82
ARL/SYS-TM-64

1/1

UNCLASSIFIED

F/G 14/2

NL

END

DATE

FORMED

2 83

DTIC

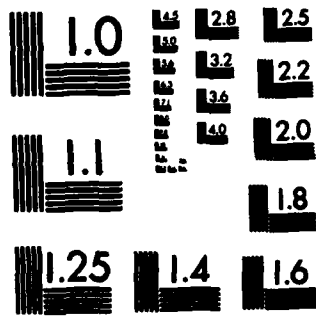

MICROCOPY RESOLUTION TEST CHART
NATIONAL BUREAU OF STANDARDS-1963-A

UNCLASSIFIED

12

ARL-SYS-TECH-MEMO-64

AR-002-908



DEPARTMENT OF DEFENCE SUPPORT
DEFENCE SCIENCE AND TECHNOLOGY ORGANISATION
AERONAUTICAL RESEARCH LABORATORIES
MELBOURNE, VICTORIA

AD A 122972

Systems Technical Memorandum 64

INVESTIGATION OF DISCREPANCIES IN MEASUREMENTS
MADE WITH A 'MINILAB' WBGT INDEX METER

A. ROSS

Approved for Public Release

DTIC
ELECTE
DEC 28 1982
S E

FILE COPY

(C) COMMONWEALTH OF AUSTRALIA 1982

COPY No

SEPTEMBER, 1982

82 12 28 01Q
UNCLASSIFIED

DEPARTMENT OF DEFENCE SUPPORT
DEFENCE SCIENCE AND TECHNOLOGY ORGANISATION
AERONAUTICAL RESEARCH LABORATORIES

Systems Technical Memorandum 64

INVESTIGATION OF DISCREPANCIES IN MEASUREMENTS
MADE WITH A 'MINILAB' WBGT INDEX METER

A. ROSS

SUMMARY

Measurements of wet bulb, dry bulb, globe temperatures and WBGT Index made with a particular 'MINILAB' were found to be mutually inconsistent. An investigation into the source of the discrepancies showed that they were largely methodological and attributable to the instrument. Individual measurements of wet, dry and globe temperatures were found to be reliable.



© COMMONWEALTH OF AUSTRALIA

POSTAL ADDRESS: Director, Aeronautical Research Laboratories,
P.O. Box 4331, Melbourne, Victoria, 3001, Australia.

CONTENTS

PAGE No.

1.	INTRODUCTION	1
2.	DATA ANALYSIS	3
3.	MINILAB	3
4.	CIRCUIT DETAILS AND ANALYSIS	4
	4.1 Circuit	4
	4.2 Meter and Scales	4
	4.3 Basic Bridge	7
	4.4 Thermistors	7
	4.5 Single Temperature Measurements	11
	4.6 Combined Index Measurements	12
	4.7 Scale Calibrations	17
5.	DISCUSSION	17
6.	CONCLUSION	19
	ACKNOWLEDGEMENT	20
	DISTRIBUTION	
	DOCUMENT CONTROL DATA	

Accession For	
NTIS GRA&I	<input checked="" type="checkbox"/>
DTIC TAB	<input type="checkbox"/>
Unannounced	<input type="checkbox"/>
Justification	
By _____	
Distribution/	
Availability Codes	
Dist	Avail and/or Special
A	



1. INTRODUCTION

As part of a continuing investigation into thermal comfort and thermal stress with particular emphasis on aircrew, a series of temperature measurements were made at RAAF Pearce in Western Australia during a three week period in February and March 1982 when the highest mid-summer temperatures were expected. The investigating team included personnel from Aeronautical Research Laboratories and from the RAAF Institute of Aviation Medicine.

Various measuring instruments and techniques were used including MINILAB WBGT Index Meters (Light Laboratories, UK), WIBGET Heat Stress Monitors (Reuter Stokes, Canada), and gastro-intestinal temperature transducers from DCIEM, Canada.

In particular the MINILAB instruments provide facilities for obtaining measurements of wet bulb temperature, dry bulb temperature, globe temperature and also a weighted sum giving WBGT. For the instrument described in this document the weighted sum could be switched to either of the nominal values:

$$\text{WBGT})_1 = 0.7 T_w + 0.3 T_g$$

$$\text{WBGT})_2 = 0.7 T_w + 0.2 T_g + 0.1 T_a$$

where

T_w is wet bulb temperature

T_g is globe temperature

T_a is dry bulb temperature.

Earlier versions of the MINILAB are understood to provide only the 0.7/0.3 weighted sum.

For the measurements made with one MINILAB it became apparent that the measured WBGTs differed from the appropriately weighted sum of the measured T_w , T_g and T_a . Discrepancies up to 2°C were noted, with the measured WBGT consistently under-reading the calculated value. The nominal accuracy of the instrument is quoted by the manufacturer as $\pm 0.5^\circ\text{C}$ over the range 10°C to 60°C for each of the parameters in question.

Whilst errors of one to two degrees, in an absolute sense, may seem to be trivial, they are in fact quite significant when near the threshold for heat stress and debilitation. By way of example the protocols adopted by the US Armed Forces on temperature (WBGT)

Limits for military activities are as given in Table 1. The WBGT span from "No restriction" to "All physical activity suspended" is only 4.5°C.

The particular investigation into aircrew thermal comfort/stress sought, inter alia, to evaluate the quality of certain relationships in predicting cockpit WBGT from ground based preflight observations of wet, dry and globe temperatures. For that purpose and in view of the high intrinsic correlations between the environment parameters, errors of 1 - 2°C in magnitude would be likely to corrupt any regression analysis to the point where results would be of doubtful value.

WBGT		ACTIVITY RESTRICTIONS
°F	°C	
Under 82	Under 27.8	No restrictions on activities
82 to 85	27.8 to 29.4	Discretion should be used in planning heavy exercise for unseasoned personnel.
85 to 88	29.4 to 31.1	Strenuous exercise such as marching at standard cadence should be suspended for unseasoned personnel with less than three weeks of hot weather training. For those with more than two weeks of training, activities may be continued on a reduced scale. Outdoor classes in the sun should be avoided.
88 to 90	31.1 to 32.2	Strenuous exercise should be curtailed for all with less than twelve weeks of hot weather training. Hardened acclimatized personnel can carry on limited activities for periods not exceeding six hours per day.
over 90	over 32.2	All physical activities should be suspended.

TABLE 1 - US Armed Forces Protocols on Temperature Limits for Military Activities.

In order to establish confidence in the trials data it was necessary to identify the source of the discrepancies and to determine whether they were methodological and attributable to measuring equipment or technique, or were the result of operator misinterpretation of the scales, or were random.

This memorandum deals with that study: the identification of the source of the discrepancies. It was concluded that the discrepancies were largely methodological and attributable to the instrument.

2. DATA ANALYSIS

All data from measurements made with a particular MINILAB were analysed in bulk with a view to determining whether a bias error or scale error in the weighting coefficients existed.

The method used was to assume that a relationship of the general form:

$$\text{WBGT}^* = a T_w + b T_g + c T_a + d$$

could be fitted to the data, and to obtain estimates of a, b, c, d by a least squares method using an error function:

$$E = \sum (e)^2 \\ = \sum \left\{ a T_w + b T_g + c T_a + d - \text{WBGT} \right\}_2^2$$

Routines were used both with and without constraints of the form:

$$a + b + c = 1$$

$$d = 0$$

The results were equivocal. Although a bias of about 1°C in the WBGT_2 values was confirmed, the residual minimum value of E was sufficiently large to indicate that the estimates of a, b, c, and d did not account for the discrepancies.

A detailed investigation of the method of operation of the MINILAB appeared to be warranted.

3. MINILAB

The principle of operation of the MINILAB instrument involves the use of three bead thermistors, as temperature sensing elements, mounted on a cruciform tree and assembled to operate as wet bulb, dry bulb and globe thermometers. Provision is made on the wet bulb arm for the attachment of a water reservoir and wick, and a ventilating fan. The globe thermistor is mounted in the centre of a blackened hollow copper sphere of nominal diameter 2 inches (50mm).

The thermistor resistances are measured singly (for T_w , T_d and T_g) or in combination (for WBGT) by means of a DC resistance bridge. The output current from the bridge is fed to a taut band indicating meter which is scaled directly in degrees Celsius.

The meter face is scaled with five ranges of which only two are pertinent to this document. One scale, 10 - 60°C is used for wet, dry and globe settings, and a separate scale, also 10 - 60°C is used for the WBGT index setting. The markings of both scales exhibit non-linearity with significant scale compression at the high temperature end such that the 30°C index points are roughly mid-scale. The differences between the scales varies across their span, and also varies between instruments. Instruments appear to be individually calibrated, presumably with particular sensor trees.

4. CIRCUIT DETAILS AND ANALYSIS

4.1 Circuit

By inspection and direct measurement of MINILAB Serial NO. K5985 the circuit shown in Figure 1 was determined. The 1500 ohm resistors provide the basic arms of the DC resistance bridge. The meter is connected across the bridge with a series resistance (presumably to adjust its sensitivity to bridge unbalance voltage). For separate measurement of wet, dry and globe temperatures the relevant thermistor, with a shunt resistor, constitutes the test arm. The reference arm is a fixed resistor (presumably trimmed to give a null bridge current at 10°C), and separate shunt resistors are switched across the meter circuit (presumably to adjust the full scale readings at 60°C).

For WBGT measurements the thermistors are arranged in series, with shunt resistors (which presumably determine their relative weighting to the WBGT index).

4.2 Meter and Scales

As near as could be judged by inspection, the meter scale extremities subtended 100 degrees of physical angle at the needle pivot point. The meter movement and scales were checked by measurement of meter current and physical angle of pointer and scales, using an AVO Mk8 multimeter and geometrical protractor. The results are as shown in Figure 2.

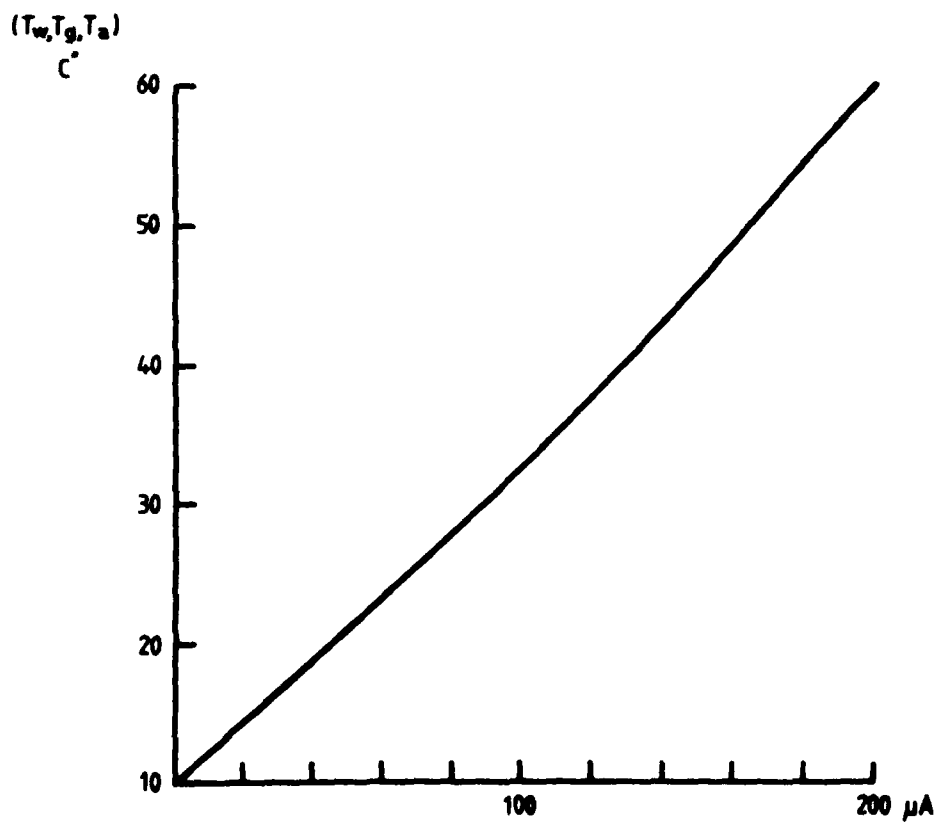
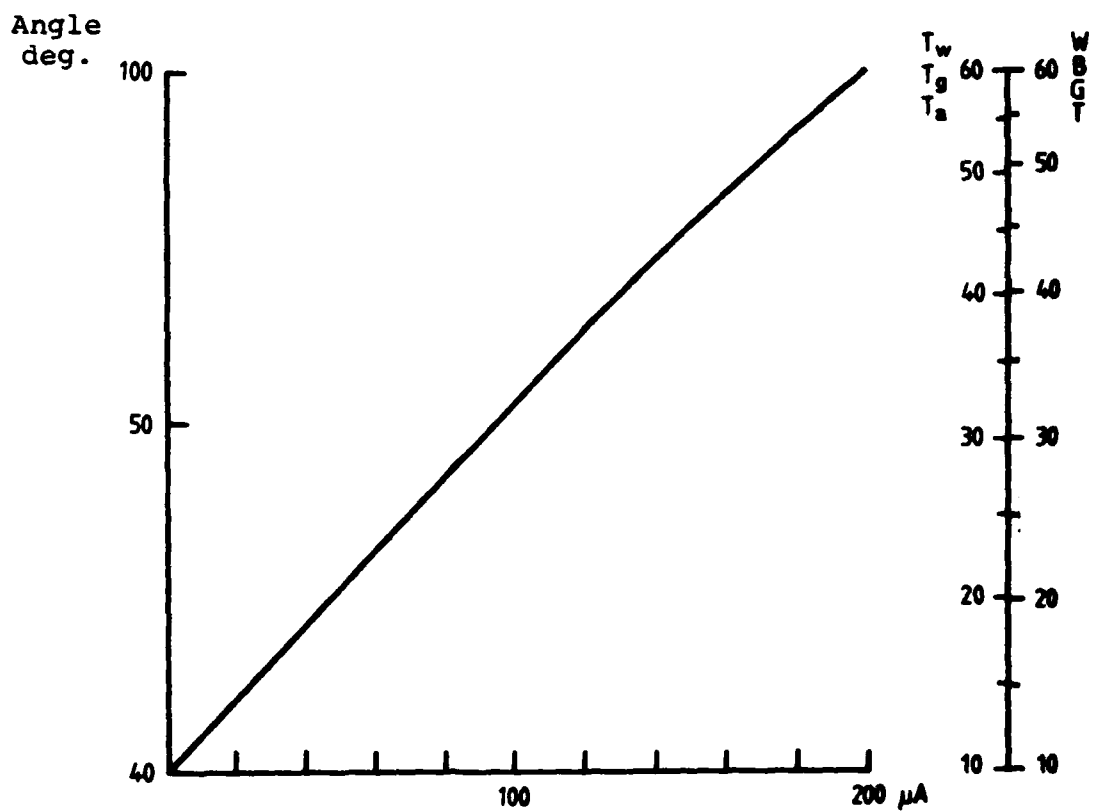

FIG. 2 METER AND SCALE CALIBRATIONS

4.3 Basic Bridge

The basic DC resistance bridge circuit is as depicted in Figure 3. Variations in R_5 (equivalent to the thermistor arm) affect the bridge offset current in two ways: firstly through the voltage offset in the divider R_4, R_5 and secondly through the effective impedance seen by the meter. Thus the incremental change in meter current, per unit change in thermistor resistance, increases as the thermistor resistance decreases.

This increasing sensitivity of the bridge configuration tends to compensate for the intrinsic characteristic of thermistors in that their incremental change in resistance, per unit change in temperature, decreases as the temperature increases.

However, the fixed resistors shunting the thermistors tend to linearise the thermistor characteristics, at least across a limited working range, and the series resistor feeding the entire bridge (Fig 1) tends to reduce the voltage across the bridge, and thus its sensitivity, as the total current increases with reducing thermistor resistance.

4.4 Thermistors

Assuming that the reference and scaling resistors were trimmed to give zero and full scale readings at 10°C and 60°C respectively, then the individual thermistor resistance values at those temperatures can be inferred both theoretically and experimentally. These thermistor values can then be used to solve for the constants A and B in the generalised thermistor law:

$$R_T = R_0 \exp (A + B/T)$$

where R_0 is one ohm and provides the dimension of resistance, and T is in degrees Kelvin. With A and B values known the thermistor characteristics are determined over the working temperature range.

From the circuit configuration and specific values of resistance (Fig 1) the thermistor resistance values for zero scale (10°C) and full scale (60°C) readings were calculated. The zero scale values depend only on resistance ratios, whereas the full scale values depend also on the supply voltage to the bridge and the meter current at full scale.

A separate experimental method was also used in which decade resistance boxes were connected in lieu of the thermistors and adjusted for zero and also for full scale readings. The settings were then measured with the ohm meter used to determine the instrument circuit values. Measured values and decade box settings were consistent to within one ohm.

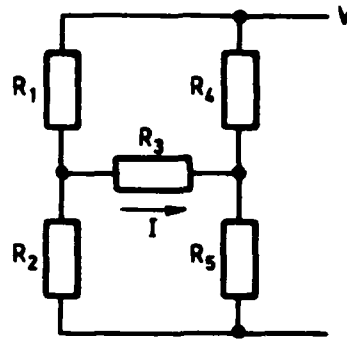

$$\frac{I}{V} = \frac{\frac{R_2}{R_1 + R_2} - \frac{R_5}{R_4 + R_5}}{\frac{R_1 R_2}{R_1 + R_2} + R_3 + \frac{R_4 R_5}{R_4 + R_5}}$$

For

- $R_1 = 1500 \Omega$
- $R_3 = 200 \Omega$
- $R_4 = 1500 \Omega$
- $R_5 = R_2 - 10 \Omega$
- $V = 3.9 \text{ v}$

R_2 Ω	R_5 Ω	I μ
200	190	37.35
180	170	40.61
160	150	44.41
140	130	48.80
120	110	54.23

FIG. 3 BASIC BRIDGE AND SENSITIVITY

The results obtained by the two methods are given in Table 2. The consistency in the results is better than had been expected. The commercial identification of the thermistors has not been established.

	THERMISTORS			
	WET	DRY	GLOBE	NOMINAL
R_{10} (ohm)				
Theoretical	163.2	171.6	165.7	
Exper. measured	163	171	166	
Decade Setting	163.8	171.9	166.5	
R_{60} (ohm)				
Theoretical	88.7	101.1	99.5	
Exper. measured	88	100	99	
Decade Setting	88.4	100.8	99.3	
Law				
A	1.0333	1.6187	1.7154	1.456
B ($^{\circ}$ K)	1149.42	998.075	960.704	1036
R_{10} (ohm)	163.180	171.652	165.689	166.8
R_{60} (ohm)	88.678	101.081	99.524	96.3

TABLE 2 - Deduced Thermistor Characteristics

Their B value of approximately 1000 $^{\circ}$ K is unusual; B values are more commonly between 2000 and 4000 $^{\circ}$ K. Direct measurement of the actual thermistors in the sensor tree confirmed, to within the measurement accuracy involved, the deduced characteristics. The 'nominal' thermistor characteristics listed were obtained by averaging the A and B values.

That nominal thermistor characteristic against temperature is shown in Figure 4, together with those resulting from various values of shunt resistance. For shunt resistance values below about 100 ohm the characteristics are effectively linear, but with reduced sensitivity to temperature variation. For shunt resistances above about 500 ohm the characteristics are significantly non-linear.

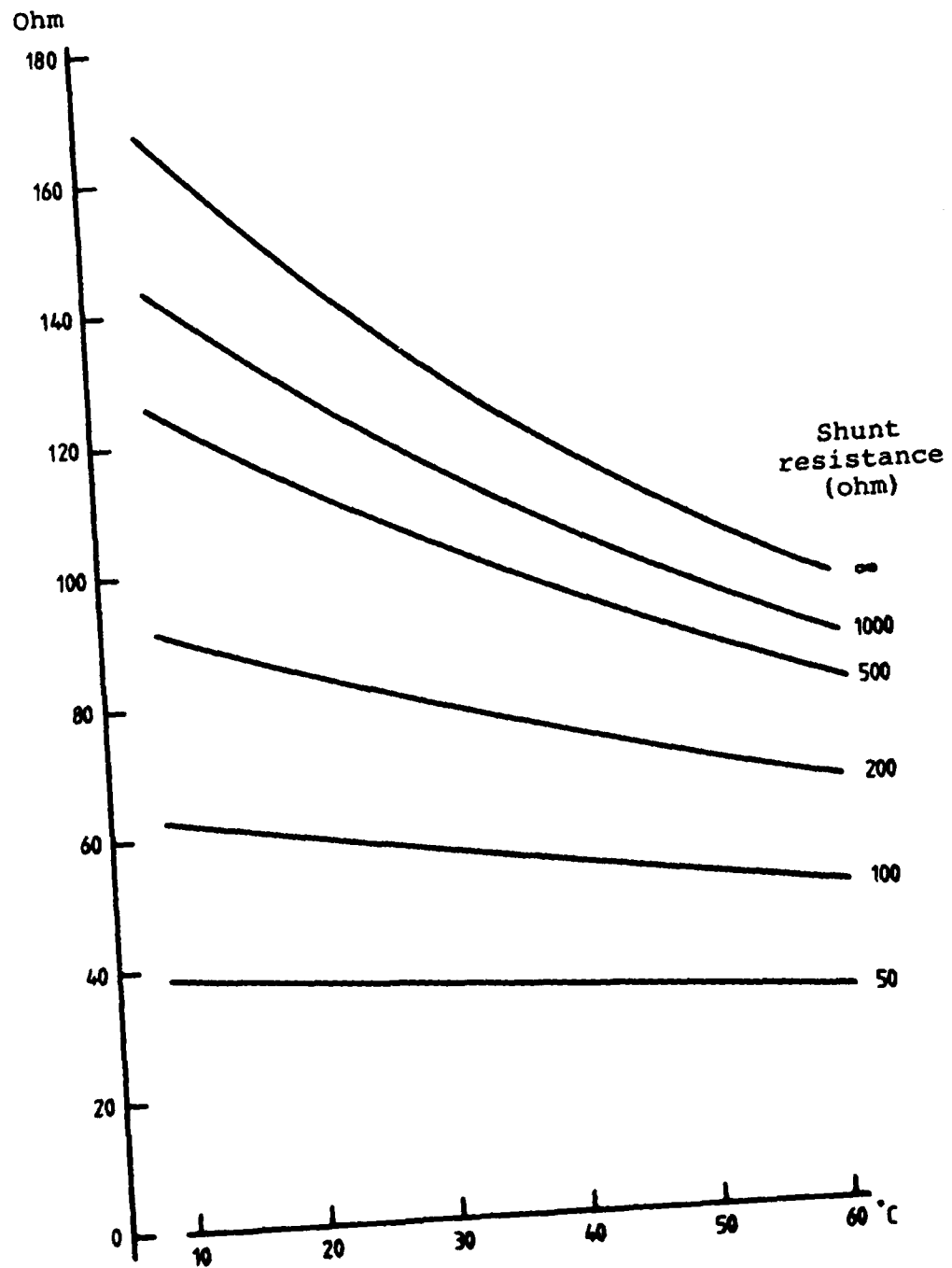

FIG. 4 CHARACTERISTICS OF NOMINAL THERMISTOR

4.5 Single Temperature Measurements

For separate measurement of wet bulb, dry bulb and globe temperatures, the arm of the bridge under measurement consists of one thermistor shunted by a single resistance. For wet and dry bulb the shunt resistance is approximately 1000 ohm and for globe approximately 500 ohm.

Using the specific circuit values (Fig 1) and individual deduced thermistor characteristics (Table 2), the meter currents were calculated for 5°C increments to check on the scale calibration and validity of common use of one scale. The results are given in Table 3. Taking 4 microamp per degree Celsius as an average sensitivity over the 10-60°C range, the consistency between the separate measurements is well within the $\pm 0.5^\circ\text{C}$ claimed for the instrument and justifies the use of a common scale. The scale calibration also appears to be just within $\pm 0.5^\circ\text{C}$.

		Wet	Dry	Globe	Nominal	Scale
		OHM				
R_S	Series	96	96	96	96	
R_1		1500	1500	1500	1500	
R_2	reference	139	146	125	142.953	
R_3	meter	202	202	202	202	
	shunt	231	365	1420	314.854	
R_4		1500	1500	1500	1500	
R_5	shunt	938	977	509	1000	
	Thermistor					
	A	1.0333	1.6187	1.7154	1.456	
	B °K	1149.42	998.075	960.704	1036	

TABLE 3 - Calculated Meter Currents vs Calibration

TABLE 3 (CONT.)

°C	Wet	Dry	Globe	Nominal	Scale
	MICROAMP				
10	0.0	0.0	0.0	0	0
15	23.9	23.9	23.6	23.9	22.5
20	47.0	46.8	46.4	46.9	46.0
25	69.1	68.9	68.4	69.0	67.5
30	90.4	90.0	89.5	90.2	89.0
35	110.7	110.4	109.8	110.6	109.5
40	130.2	129.8	129.3	130.0	128.5
45	148.9	148.5	148.1	148.7	148.0
50	166.7	166.4	166.1	166.6	165.0
55	183.7	183.6	183.4	183.6	182.0
60	200.0	200.0	200.0	200	200

4.6 Combined Index Measurements

For the WBGT Index measurements the thermistors are combined in series, each with shunt resistors which determine the effective weightings. Ideally the weightings should not be temperature dependent. In fact, due to the non-linear thermistor characteristics there will be some temperature dependence which will be more marked for the higher weighting on the wet bulb temperature - due to the fact that a larger valued shunt resistance is required, by comparison with the other weightings.

From the circuit details, the effective values of the resistance appearing in shunt in the index settings are as given in Table 4, and the calculated values for the DC bridge reference arms

	Wet	Dry	Globe
	OHM		
WBGT) ₁	240.526	0	115.857
WBGT) ₂	315.322	54.750	95.133

TABLE 4 - Thermistor Shunts In Index Mode

are 209.476 ohm for WBGT)₂ (cf 210 ohm), and 165.404 ohm for WBGT)₁ (cf 210 parallel 793 ohm; 166.032 ohm). Again, the consistency is better than expected.

The variation of effective resistance with temperature, of the combination of a thermistor R_T and a shunt resistance R_S is given by:

$$\begin{aligned} \frac{dR}{dT} &= \frac{d}{dT} \left\{ \frac{R_S R_T}{R_S + R_T} \right\} \\ &= - \frac{B}{T^2} R_T \left\{ \frac{R_S}{R_S + R_T} \right\}^2 \end{aligned}$$

where

$$R_T = \exp(A + B/T).$$

Using the R_S values from Table 4 and the A and B values from Table 3 yields the derivatives and normalised weightings (normalised to unity sum at each temperature) given in Table 5. From the values of normalised weights against temperature it appears that the nominally desired weights have been set up for about 20 - 25°C.

	Wet	Dry	Globe	Wet	Dry	Globe
WBGT) ₁	OHM/DEG			NORM. WEIGHT		
10°C	- 0.832	0	- 0.337	0.712	0	0.288
22°C	- 0.736	0	- 0.316	0.700	0	0.300
35°C	- 0.642	0	- 0.293	0.687	0	0.313
60°C	- 0.491	0	- 0.249	0.663	0	0.337
WBGT) ₂						
10°C	- 1.017	- 0.125	- 0.264	0.723	0.089	0.188
22°C	- 0.883	- 0.124	- 0.251	0.702	0.098	0.200
35°C	- 0.755	- 0.121	- 0.236	0.679	0.108	0.212
60°C	- 0.560	- 0.112	- 0.206	0.637	0.128	0.235

TABLE 5 - Resistance Slopes and Normalised Weights

It follows also that for any particular WBGT (by formal definition) then for increasing magnitude of wet bulb depression and compensating globe elevation, the indicated value will give increasing weight to the wet bulb value and decreasing weight to the globe value.

This effect is shown in Figures 5 and 6. The Figures were generated from the deduced individual thermistor characteristics and specific circuit values for the shunting resistors. For each WBGT the nominal value of the series/shunt combination was calculated for common thermistor temperatures and then varied to give the same overall resistance value. Figure 5 shows the two parameter system for WBGT₁. For WBGT₂ the three parameter system requires a three dimensional representation. For Figure 6 the plot is reduced to two parameters by constraining globe temperature to follow dry bulb with a globe elevation of 10°C.

Figures 5 and 6 do not include any scale calibration error that might exist in the WBGT scale.

It is apparent from the Figures that for globe elevations and wet bulb depressions of less than 10°C in magnitude, the methodological errors are less than ±0.5°C in WBGT.

In order to check the WBGT scale calibration and validity of using a common scale for WBGT₁ and WBGT₂ the meter currents were calculated for 5°C increments using the specific circuit values (other than for the reference arm resistors) and deduced thermistor constants, taking common temperatures for the thermistors. The results are given in Table 6. The reference arm resistance values were taken as the calculated values in order to force a zero scale reading for 10°C. The 0.5 ohm discrepancy is of the order of the experimental measuring accuracy, but is equivalent to about 0.5°C offset or 2 microamp meter current.

	WBGT ₁	WBGT ₂	Rescale
°C	MICROAMP		
10	0	0	0
15	21.9	22.0	22.1
20	43.4	43.6	43.8
25	64.5	64.6	65.0
30	85.1	85.3	85.8
35	105.3	105.4	106.1
40	124.9	125.0	125.9
45	144.1	144.1	145.2
50	162.8	162.7	163.9
55	180.9	180.9	182.2
60	198.6	198.5	200

TABLE 6 Calculated Meter Currents - Index Mode

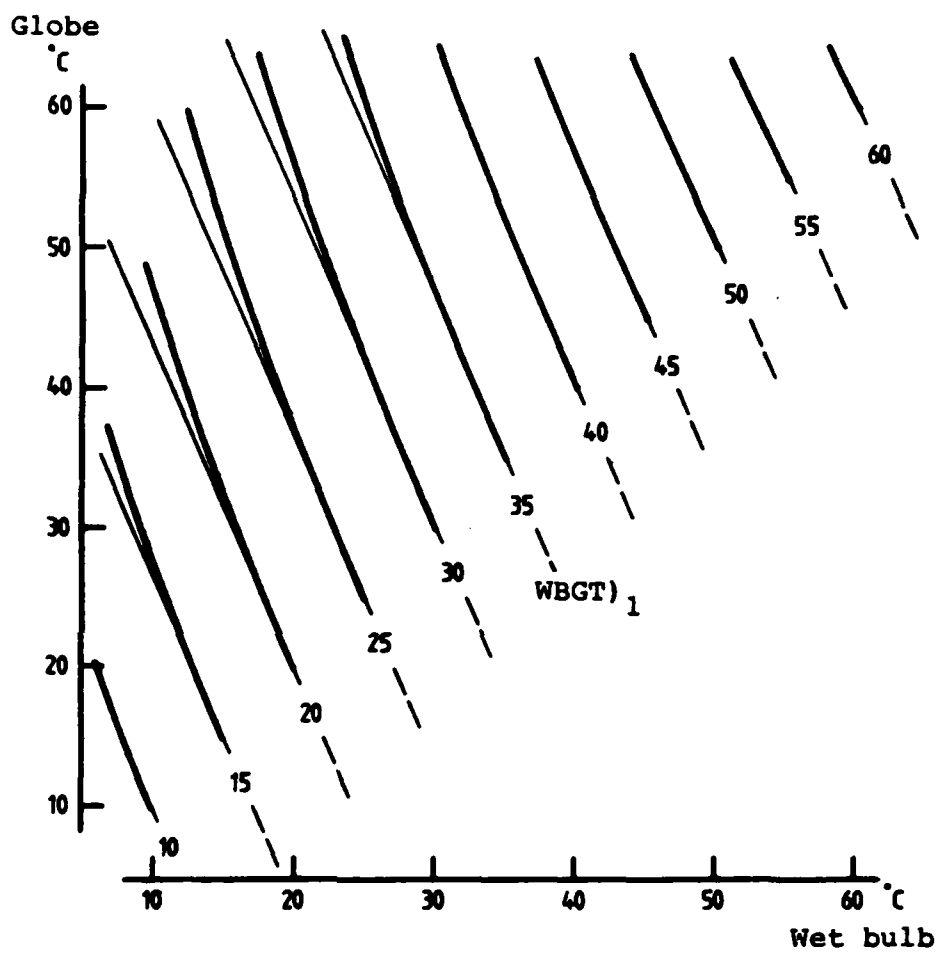

FIG. 5 WBGT) ₁ LOCI

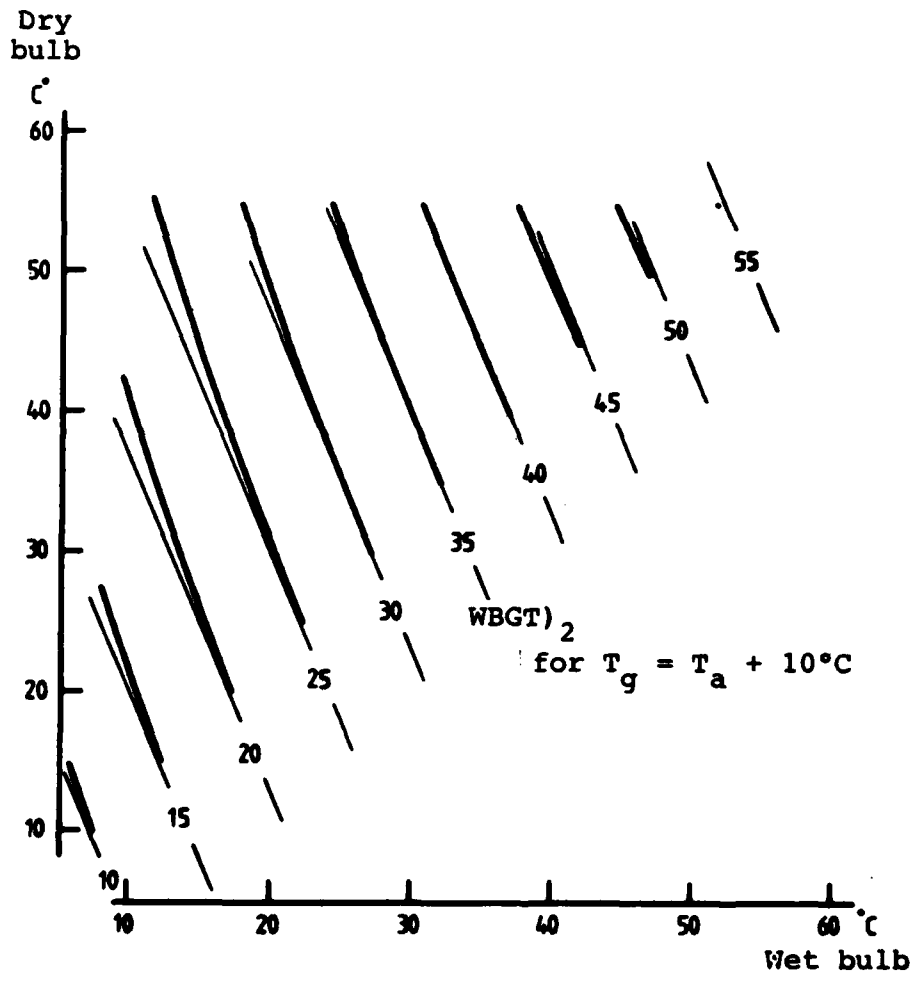

FIG. 6 WBGT)₂ LOCI FOR T_g = T_a + 10°C

In fact, with the experimental technique of using decade resistance boxes in lieu of thermistors, and with the values adjusted to give zero scale readings for wet, dry and globe, on switching to Index mode to check that zero, an offset of approximately 0.5°C high was found. A similar 0.25°C high offset was found at the full scale settings.

The calculated currents (Table 6) show very high consistency between the two settings for WBGT weights and justify the use of a common scale. In the last column of Table 5 the average of the two currents has been rescaled to give an exact full scale value of 200 microamp at 60°C so that direct comparison may be made with the values given in Table 3 for the Wet/Dry/Globe scale.

4.7 Scale Calibrations

From the calculated meter currents (Tables 3 and 6) it is seen that the use of two separate scales, one for Wet/Dry/Globe and one for WBGT)₁/WBGT)₂ is warranted. On the basis of the calculated currents the two scales should differ in the mid-scale region by approximately 1°C, with the WBGT scale showing less non-linearity than Wet/Dry/Globe scale. That is not the case with the instrument calibration marks.

The lesser degree of non-linearity in WBGT currents stems directly from the use of lower valued shunt resistances - by comparison with individual temperature measurements - which improve the linearity (see Fig 4) of the thermistor resistor combination.

In Figure 7 the calculated scales are compared with the actual instrument scales. The scales are plotted on a dimension of meter current and not graphical angle as in Figure 2. The instrument WBGT scale appears to be incorrect. Two other MINILAB instruments, available for inspection, were found to have their scales somewhat similar to the calculated scales (Fig 7b) in that they differed by about 1°C in mid-scale and had less non-linearity in the WBGT scale than in the Wet/Dry/Globe scale.

For the instrument under examination the WBGT scale would under-read, in mid-scale, by about 1°C.

5. DISCUSSION

The set of trials data in which discrepancies were noted involved temperatures, as measured by the instrument, of:

wet bulb	:	15 - 30°C
dry bulb	:	25 - 55°C
globe	:	35 - 60°C
and WBGT) ₂	:	20 - 40°C.

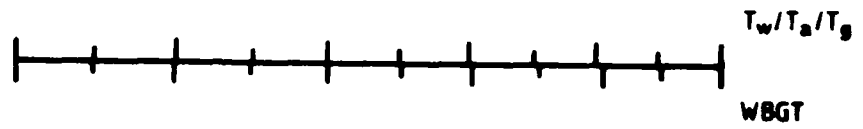

(a) Instrument scales

10 20 30 40 50 60 °C

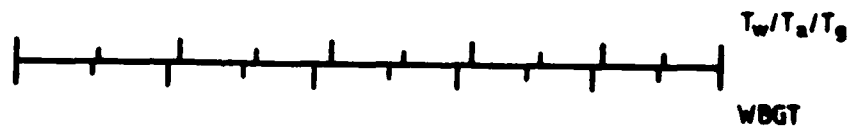

(b) Calculated scales

FIG. 7 COMPARISON OF CALCULATED AND ACTUAL SCALES

On occasions the globe temperature exceeded full scale. Over these ranges there are three potential sources of discrepancies which are additive, and for which the cumulative effects correspond with the magnitude of errors being sought in the raw trials data.

The dominant source of error appears to lie in the WBGT scale calibration (Fig 7). For true $WBGT)_2$ values in the 25 - 40°C region, the instrument WBGT scale would give rise to about 1°C under-read error. (It is of interest to note that the instrument WBGT scale corresponds very closely with the calculated $T_w/T_a/T_g$ scale and points to a possible reason for a scale marking error.)

Secondary sources of additive, but minor, discrepancies lie in the $T_w/T_a/T_g$ scale error in the region of 50°C and in the temperature dependency of the actual WBGT weightings.

From a comparison of the instrument and calculated scales for $T_w/T_a/T_g$ (Fig 7a. & b.) it appears that temperatures in the 45 - 55°C region are likely to be over-read by about 0.5°C. As a consequence a calculated value for WBGT based on measured T_a/T_g values in that region will over-estimate by up to 0.2°C.

With respect to WBGT weightings, for large wet bulb depressions (ie of greater than 10°C) at wet bulb values in the region of 10 - 20°C, the relative weightings embodied in the instrument are likely to give rise to about 0.5°C or more error in $WBGT)_2$ of an under-read nature (Fig 6).

These three effects are additive and taken together correspond with the magnitude of error being sought in the raw trials data.

For a number of spot cases checked, interpreting the raw trials data sets through the instrument scales (Fig 7a.) to the calculated scales (Fig 7b.) reduced the discrepancies to below 0.5°C. This procedure accounts for scale marking errors but not for the effects of temperature dependency of WBGT weighting.

6. CONCLUSION

With respect to the raw trials data sets, it is recommended that the measured values for $WBGT)_2$ obtained with MINILAB Serial No. K5985 be discarded, and replaced by calculated values based on the measured wet bulb, dry bulb and globe temperatures. These individual measurements appear to be reliable and accurate, with a potential over-read of about 0.5°C limited to dry bulb and/or globe temperatures in the region of 45 - 55°C. This is within the nominal accuracy of the instrument.

From Figure 7 it appears that the instrument WBGT scale is incorrectly calibrated and likely to yield errors of about 1°C over most of its range. If the normal use of the instrument is to obtain direct readings of WBGT, then recalibration appears to be warranted.

From Table 5 and Figures 5 and 6 it appears that the non-linear characteristics of the thermistors are not sufficiently well compensated for the weighting laws to be valid over the full temperature range of the instrument. However errors due to that cause are not significant unless the wet bulb depression is greater in magnitude than about 10°C.

ACKNOWLEDGEMENT

The author wishes to acknowledge the contribution of Mr. J. Zosens of ARL in probing the entrails of the instrument to deduce its circuit configuration.

DISTRIBUTION

AUSTRALIA

Department of Defence

Central Office

Chief Defence Scientist)
Deputy Chief Defence Scientist)
Superintendent, Science and Technology Programmes) (1 copy)
Controller, Projects and Analytical Studies)
Defence Science Representative (U.K.) (Doc Data sheet only)
Counsellor, Defence Science (U.S.A.) (Doc Data sheet only)
Defence Central Library
Document Exchange Centre, D.I.S.B. (17 copies)
Joint Intelligence Organisation
Librarian H Block, Victoria Barracks, Melbourne
Director General - Army Development (NSO) (4 copies)

Navy Office

Navy Scientific Adviser
Director General, Naval Health Services

Army Office

Army Scientific Adviser
Director General, Army Health Services
OC Australian Army Aviation Centre, Oakey

Air Force Office

Air Force Scientific Adviser
Director General, Air Force Health Services
CO, Institute of Aviation Medicine, Point Cook (2 copies)

Department of Defence Support

Aeronautical Research Laboratories

Director
Library
Superintendent - Systems
Divisional File - Systems
Author: A. Ross (2 copies)
PO Cybernetics Group (3 copies)

Materials Research Laboratories

Director/Library
Superintendent - Organic Chemistry Division,
Attn. SPRS Physiology

.../cont.

DISTRIBUTION (CONT.)

Defence Research Centre

Library

RAN Research Laboratory

Library

CANADA

Defence and Civil Institute of Environmental Medicine
Biosciences Division, Dr L. Kuehn
CAARC Coordinator, Human Engineering

INDIA

CAARC Coordinator, Human Engineering

NEW ZEALAND

OC, Defence Environmental Medical Unit
CAARC Coordinator, Human Engineering

UNITED KINGDOM

Light Laboratories
Royal Air Force Institute of Aviation Medicine, Thermal
Physiology Group
CAARC, Secretary (NPL)
CAARC Coordinator, Human Engineering

UNITED STATES OF AMERICA

NASA Scientific and Technical Information Facility
United States Air Force School of Aerospace Medicine,
Dr. S. Nunneley

SPARES (10 copies)

TOTAL (60 copies)

DOCUMENT CONTROL DATA

1. a. AR No AR-002-908	1. b. Establishment No ARL-SYS-TECH-MEMO-64	2. Document Date September 1982	3. Task No AIR 82/083
4. Title INVESTIGATION OF DISCREPANCIES IN MEASUREMENTS MADE WITH A 'MINILAB' WBGT INDEX METER		5. Security a. document UNCLASSIFIED	6. No Pages 20
		b. title U	c. abstract U
7. No Refs -		8. Author(s) A. ROSS	
9. Downgrading Instructions -		10. Corporate Author and Address Aeronautical Research Laboratories P.O. Box 4331, MELBOURNE Vic 3001	
11. Authority (as appropriate) a.Sponsor b.Security c.Downgrading d.Approval -		12. Secondary Distribution (of this document) Approved for public release Overseas enquirers outside stated limitations should be referred through ASDIS, Defence Information Services Branch, Department of Defence, Campbell Park, CANBERRA ACT 2601	
13. a. This document may be ANNOUNCED in catalogues and awareness services available to ... No limitations			
13. b. Citation for other purposes (ie casual announcement) may be restricted unrestricted to for use			
14. Descriptors Heat stress (physiology) Heat stress indices Wet bulb temperature Minilab WBGT index meter Dry bulb temperature Instrument characteristics Globe temperature		15. COSATI Group 0505 1402	
16. Abstract Measurements of wet bulb, dry bulb, globe temperatures and WBGT Index made with a particular 'MINILAB' were found to be mutually inconsistent. An investigation into the source of the discrepancies showed that they were largely methodological and attributable to the instrument. Individual measurements of wet, dry and globe temperatures were found to be reliable.			

This page is to be used to record information which is required by the Establishment for its own use but which will not be added to the DISTIS data base unless specifically requested.

16. Abstract (Contd)		
17. Imprint Aeronautical Research Laboratories, Melbourne		
18. Document Series and Number SYSTEMS TECHNICAL MEMORANUM 64	19. Cost Code 734460	20. Type of Report and Period Covered -
21. Computer Programs Used -		
22. Establishment File Ref(s) -		