



MRDC41082.9AR

AD A 122987

# RESEARCH ON SAW SENSOR BIAS STABILITY

## ANNUAL TECHNICAL REPORT FOR THE PERIOD October 1, 1981 through October 1, 1982

ARPA ORDER NO. 4061  
CONTRACT NO. MDA903-81-C-0081

Prepared for

Defense Supply Service  
Department of Army  
Washington, D.C. 20310

E.J. Staples  
& A.P. Andrews  
Principal Investigators  
805/498-4545

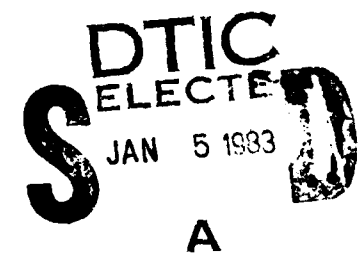

"Contract effective dates from October 17, 1980, through September 30, 1982"

The views and conclusions contained in this document are those of the authors and should not be interpreted as necessarily representing the official policies, either expressed or implied, of the Defense Advanced Research Projects Agency or the U.S. Government.

DTIC FILE COPY



**Rockwell International**  
Microelectronics Research  
and Development Center

This document has been approved for public release and sale; its distribution is unlimited.

83 01 05 003

UNCLASSIFIED

SECURITY CLASSIFICATION OF THIS PAGE (When Data Entered)

REPORT DOCUMENTATION PAGE		READ INSTRUCTIONS BEFORE COMPLETING FORM
1. REPORT NUMBER	2. GOVT ACCESSION NO. AD A122 987	3. RECIPIENT'S CATALOG NUMBER
4. TITLE (and Subtitle) RESEARCH ON SAW SENSOR BIAS STABILITY		5. TYPE OF REPORT & PERIOD COVERED Annual Technical Report 10/1/81 through 10/1/82
		6. PERFORMING ORG. REPORT NUMBER MRDC41082.AR
7. AUTHOR(s) E. J. Staples, 805-498-4545 A. P. Andrews		8. CONTRACT OR GRANT NUMBER(s) MDA903-81-C-0081
9. PERFORMING ORGANIZATION NAME AND ADDRESS Rockwell International Science Center 1049 Camino Dos Rios Thousand Oaks, CA 91360		10. PROGRAM ELEMENT, PROJECT, TASK AREA & WORK UNIT NUMBERS AROA Order No. 4061
11. CONTROLLING OFFICE NAME AND ADDRESS Defense Supply Service Department of Army Washington, D.C. 20310		12. REPORT DATE October 1982
		13. NUMBER OF PAGES 26
14. MONITORING AGENCY NAME & ADDRESS (if different from Controlling Office) Director, Advanced Research Projects Agency 1400 Wilson Boulevard Arlington, VA 22209		15. SECURITY CLASS. (of this report) UNCLASSIFIED
		15a. DECLASSIFICATION/DOWNGRADING SCHEDULE
16. DISTRIBUTION STATEMENT (of this Report) Approved for public release; distribution unlimited.		
17. DISTRIBUTION STATEMENT (of the abstract entered in Block 20, if different from Report)		
18. SUPPLEMENTARY NOTES		
19. KEY WORDS (Continue on reverse side if necessary and identify by block number) Surface Acoustic Wave (SAW) Accelerometer, Bias Stability . . . Frequency Stability, Inertial Navigation . . . Crystal Resonator Aging, Temperature Compensation, Chemical Etching of Quartz		
20. ABSTRACT (Continue on reverse side if necessary and identify by block number) The objective is to develop SAW accelerometers with improved bias stability characteristics for moderately accurate inertial navigation. Methods of fabricating dual-resonator crystals with low absolute and differential aging characteristics have been developed. Tests have been performed on integrated noise levels for simulated guidance system mission times of up to 20 minutes. Error rates less than 50 meters per hour in position of accuracy have been achieved.		

DD FORM 1 JAN 75 1473

EDITION OF 1 NOV 65 IS OBSOLETE

UNCLASSIFIED

SECURITY CLASSIFICATION OF THIS PAGE (When Data Entered)

**SECURITY CLASSIFICATION OF THIS PAGE(When Data Entered)**

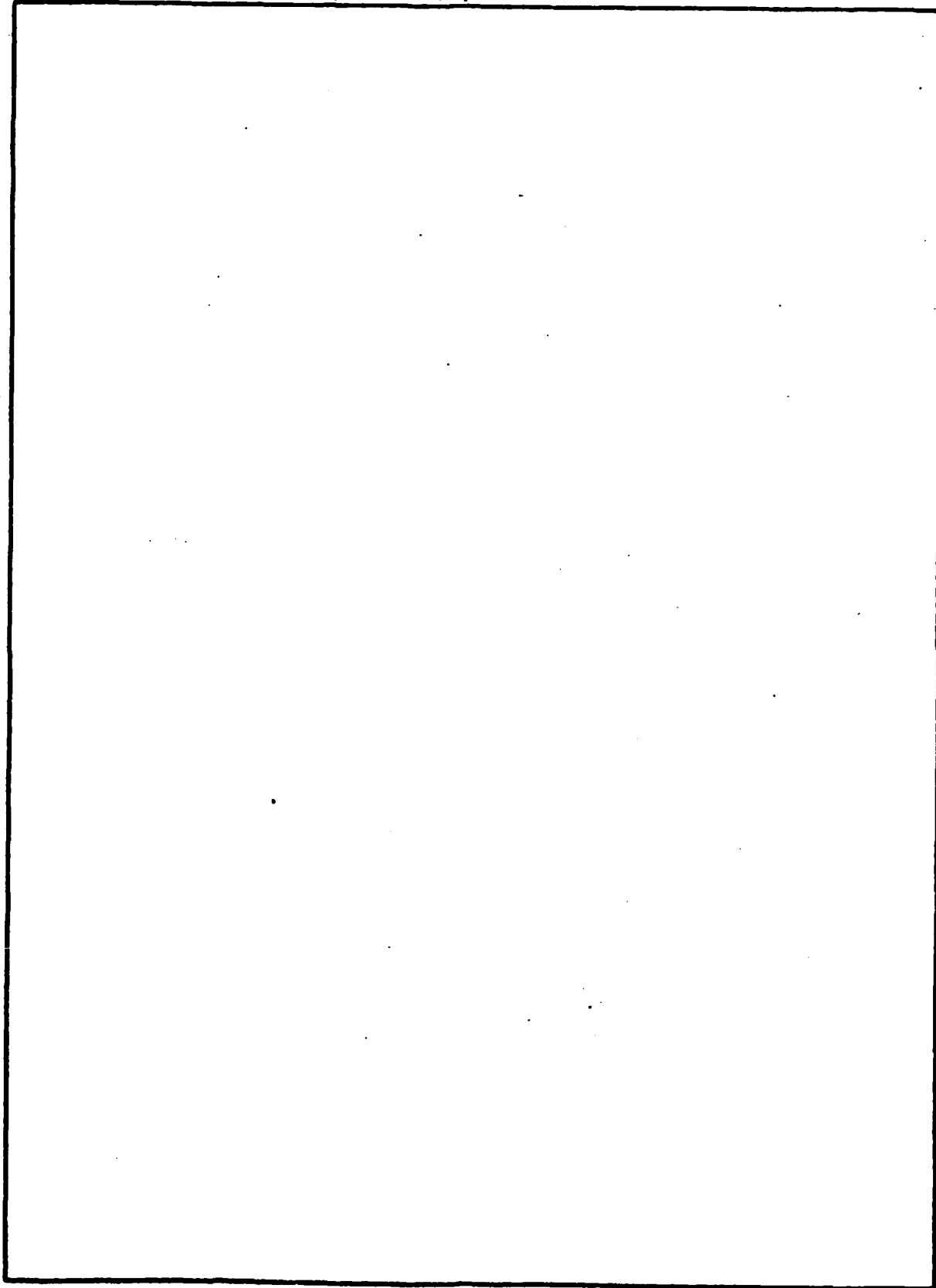

**SECURITY CLASSIFICATION OF THIS PAGE(When Data Entered)**



TABLE OF CONTENTS

	PAGE
LIST OF FIGURES	ii
1.0 Progress and Technical Report Summary	1
2.0 Technical Problem	3
3.0 Technical Results	6
3.1 Temperature Tracking of Dual SAW Resonators	6
3.2 Temperature Compensation	10
3.3 Beams of Chemical-Etched Quartz	13
4.0 Future Plans	16
5.0 Publications and Presentations	19
6.0 References	20
7.0 Appendix I--Inertial Guidance and Underwater Sound Detection Using SAW Devices	21

Accession For

TRIS GRA&I

Dist Iss

Unannounced

Justification

---

Distribution/

Availability Codes

Avail and/or

Dist Special

A





LIST OF FIGURES

FIGURE	PAGE
1. Histograms of (a) Frequency and (b) Temperature for a SAW Sensor	7
2. Frequency versus Temperature for a SAW Sensor	9
3. Bias Stability versus Temperature for a SAW Sensor	9
4. Block Diagram of Temperature Compensated SAW Sensor	11
5. Frequency as a Function of Temperature for Prototype SAW Sensor	12
6. Photograph of 5 Hammer-Head Cantilever Beams and Teflon Clamp for Mounting the Cantilever Beam	15



## 1.0 PROGRESS AND TECHNICAL REPORT SUMMARY

The objective of this program is to perform fundamental studies on SAW resonators leading to: 1) improved bias stability characteristics for acceleration sensors, and 2) a fabrication method for hammer-head cantilever beams in quartz. The end goal is to develop small, low-cost and moderately accurate accelerometers for tactical guidance systems.

During the second year, progress has been made in several areas which are discussed in this report. A computerized measurement system was designed using an automatic frequency counter, a programmable environmental chamber, and a scanner data acquisition system. Software was designed to control temperature and read the frequency of oscillators simultaneously.

Methods of fabricating dual-resonator crystals with low absolute and differential aging characteristics have been developed. Also, hybrid oscillator circuitry has been studied and preliminary results using dual-resonator sensing crystals showed excellent stability, typically less than  $1 \times 10^{-10}$  for 1 second average times. Tests have also been performed on integrated noise levels for simulated guidance system mission times of up to 20 minutes. Error rates less than 50 meters per hour in position of accuracy have been achieved.<sup>1</sup> These data indicate that SAW accelerometers are considerably better than



Rockwell International

MRDC41082.9AR

existing moderately accurate sensors which commonly have error rates of 1 nautical mile (equivalent to 1852 meters) per hour.



## 2.0 TECHNICAL PROBLEM

There is a constant need for less costly accelerometers, especially for applications such as cruise missiles and tactical missiles, for which large numbers of accelerometers are required. Many technological approaches have been proposed for meeting this need. These include vibrating string,<sup>2</sup> laser,<sup>3</sup> piezoresistive,<sup>4</sup> piezoelectric,<sup>5</sup> and acoustic accelerometers.<sup>6,7</sup> All of these approaches use a "proof mass" which is connected to the host vehicle by means of a stress sensor. The stress sensor measures the force applied to the proof mass, which is proportional to the sensed acceleration of the host vehicle. These are "open loop" sensors, because the force is not applied by a precision servo loop, as in the case of the gyroscopic and pendulous accelerometers.

Planar cantilever devices show promise for meeting these needs with an open-loop accelerometer without bearings or points of wear. By using established planar fabrication techniques, it is possible to make an integrated circuit containing strain-sensitive elements on a substrate which acts as a clamped plate or beam. Acceleration forces on this device will cause surface strains that are sensed and processed by the electronic circuit. This type of accelerometer can potentially be inexpensive. It uses little power and can be made small and reliable.

Ideally, the acceleration sensor should be able to operate over the full operational range of ambient temperatures without



temperature control. Depending upon the systems application, this temperature range can be as great as 179°C, for Class IV avionics,<sup>8</sup> or as small as 109°C, for Class I avionics. Conventional accelerometers are not likely to perform as well as cantilever devices over such large temperature variations, because their design depends upon different properties of different materials, and these are difficult to maintain in the proper relationship over large variations in temperature. For example, floated devices depend upon the bouyancy and viscosity of fluids, and it is unlikely that they can be adequately matched over a large range of temperatures. Similarly, the designs of electromagnetic and drag-cup devices depend upon the mechanical and magnetic properties of magnetic and non-magnetic materials, and it is also unlikely that these properties can be adequately matched over large temperature ranges. Also, the thermal expansion of dissimilar materials causes stresses or strains that lead to mechanical instability in clamped assemblies with repeated temperature cycling.

The surface acoustic wave (SAW) resonator is a strain-to-frequency converter. It consists of an interdigital transducer between reflective gratings on a piezoelectric (quartz) substrate. A signal applied to the transducer launches Rayleigh-mode waves along the surface of the substrate, which are coherently reflected by the gratings. A feedback electronic circuit maintains the cavity in resonance. This uses a single dc



voltage source for power, and generates an output signal at the resonator frequency. An additional buffer amplifier may be required for signal level shifting to compatible logic levels.

Longitudinal strain applied to the resonator cavity will cause a proportional change in its resonant frequency.<sup>6,7</sup> This provides a bit rate frequency output which is proportional to strain input. This relationship forms the basis of the simplest SAW accelerometer. This accelerometer is a simple cantilever-beam configuration. Acceleration applied at the clamped end is transmitted to the proof mass at the free end through bending stress. The resulting surface strain along the SAW resonator causes a frequency shift which is proportional to the applied acceleration.

The objective of this program is to perform fundamental studies on SAW resonator processing methods that yield stability characteristics which successfully meet the bias stability requirements of inertial navigation accelerometers. The technical problems involved are SAW resonator fabrication methodology, absolute and differential aging measurements, design and characterization of high frequency sensor circuitry which is hybridized in a single package and common mode noise rejection including temperature effects.



### 3.0 TECHNICAL RESULTS

During the second year of this program, the specific technical tasks were:

1. To design and construct hybrid rf circuitry for prototype SAW accelerometers. The circuitry must be low in cost and power, and provide long-term stability. The technical problem was to operate two oscillators from a single crystal in a single package without experiencing lock-up of the oscillators to a common frequency.

2. To develop a chemical etch for etching single crystal quartz into arbitrary shaped cantilever beams. This was needed for etching the hammer-head cantilever beam.

3. To determine the inertial errors of prototype SAW dual acceleration sensors in terms of the integrated velocity and displacement errors. Tests were performed on integrated noise levels for simulated guidance system mission times of up to 20 minutes. Error rates less than 50 meters/hour in position accuracy were achieved.<sup>1</sup> These data indicated that SAW accelerometers were considerably better than existing moderately accurate sensors which commonly had error rates of 1 nautical mile (equivalent to 1852 meters) per hour.

#### 3.1 Temperature Tracking of Dual SAW Resonators

Studies of the temperature tracking of dual SAW resonator crystals were made and showed that the cycling of temperature



over a suitable range was required while simultaneously monitoring bias stability or the difference frequency of SAW sensors.

A computerized measurement system was designed using an automatic frequency counter, a programmable environmental chamber, and a scanner data acquisition system. Software was designed to control temperature and read the frequency of oscillators simultaneously. Shown in Fig. 1 were test results for two SAW oscillators configured around a sensor crystal. The results were plotted during data acquisition as histograms. The top two traces showed oscillator frequency and the bottom trace showed temperature in the environmental chamber. The chamber was programmed to increase temperature 2 degrees per minute until 80°C is reached. The temperature was held for 15 minutes and then reduced at -2 degrees per minute until 25°C was reached. The cycle was then repeated if desired.

After the test had been run and the data collected, new plots were made showing frequency versus temperature, given in Fig. 2, as well as frequency difference (bias stability) versus temperature as shown in Fig. 3. The technical goal was to show little or no bias stability shift vs. temperature. The results of Fig. 3 indicated a difference in turning point which in turn caused a non-zero bias instability with temperature. Numerous tests of this kind have been made. As a result of our extensive studies, the major source of bias instability with temperature

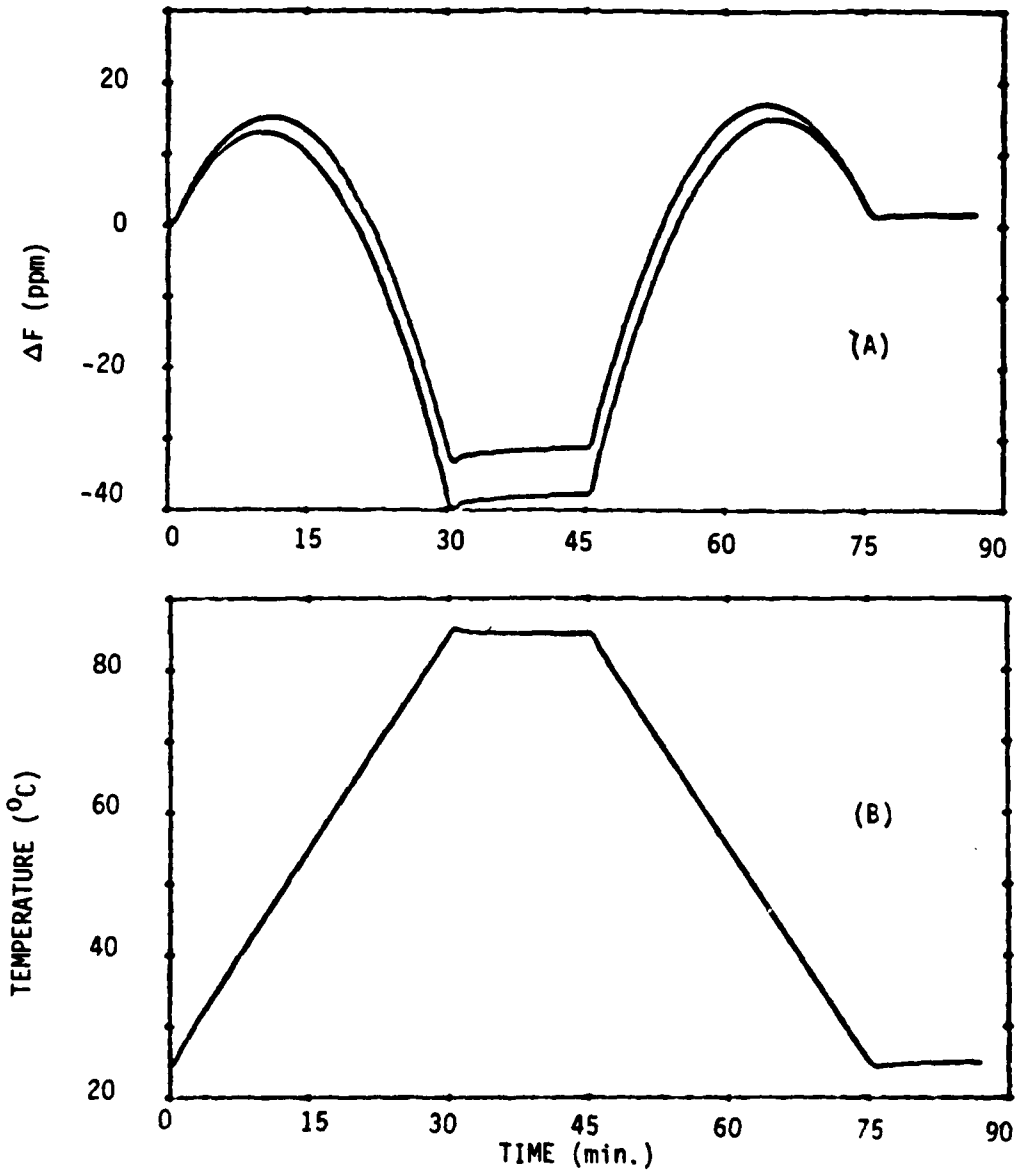

Figure 1--Histograms of (a) frequency and (b) temperature for a SAW sensor.



MRDC41082.9AR

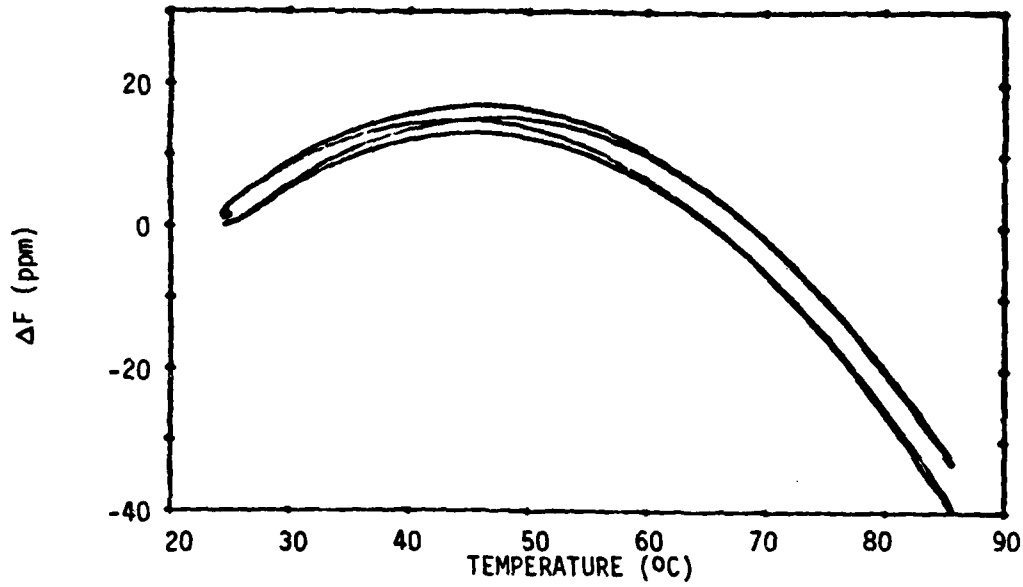

Figure 2--Frequency versus Temperature for a SAW Sensor

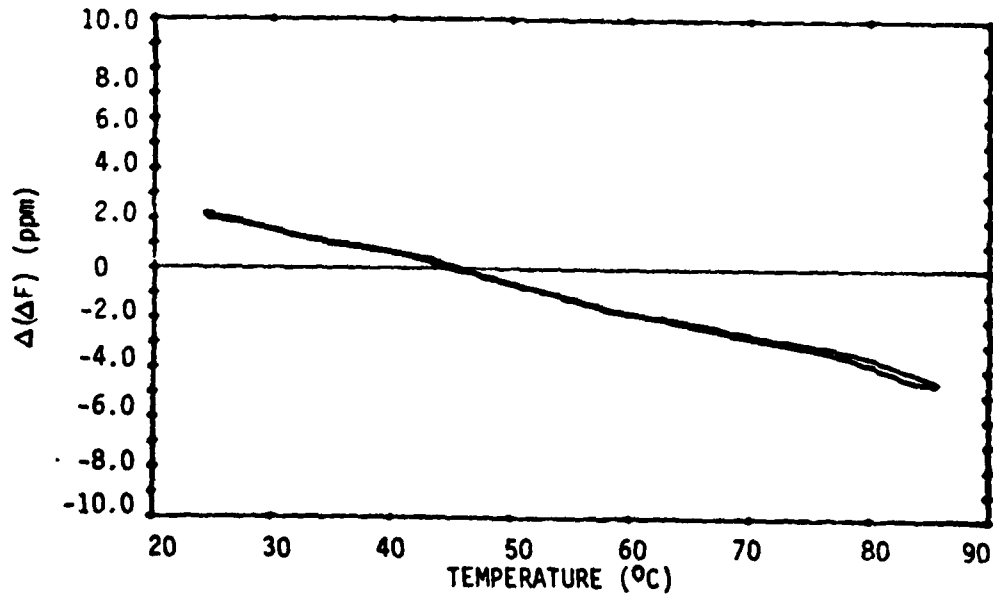

Figure 3--Bias Stability versus Temperature for a SAW Sensor



was due to non-uniform metalization thickness in the resonator electrodes.

Tighter control in the metal deposition in the later experiments showed an improved bias stability with temperature.

### 3.2 Temperature Compensation

Methods of temperature compensating SAW oscillator-sensors were investigated. Design studies indicated temperature compensation circuitry configured as shown in Fig. 4 could maintain the sensor frequencies provided a phase shift could be introduced which was opposite to that of the surface wave crystal, in this case a parabolic temperature characteristic. Several circuits were designed using varactor diode phase shifting networks.

To test the design feasibility, experimental temperature compensated oscillators were built. Surface wave two-pole crystal filters were used as feedback elements in order to extend the temperature range over which the oscillators could be compensated. Prototype crystals operating nominally at 198 MHz were fabricated and placed in oscillator feedback circuits which contained parabolic phase shifting networks.

Frequency vs. temperature for a test circuit over the range 0° to 100°C is shown in Fig. 5. Multiple scans are shown indicating hysteresis which was due to unsealed crystal units in these prototype circuits. Nevertheless temperature compensation is evident and the frequencies were held to within  $\pm 35$  ppm as



MRDC41082.9AR

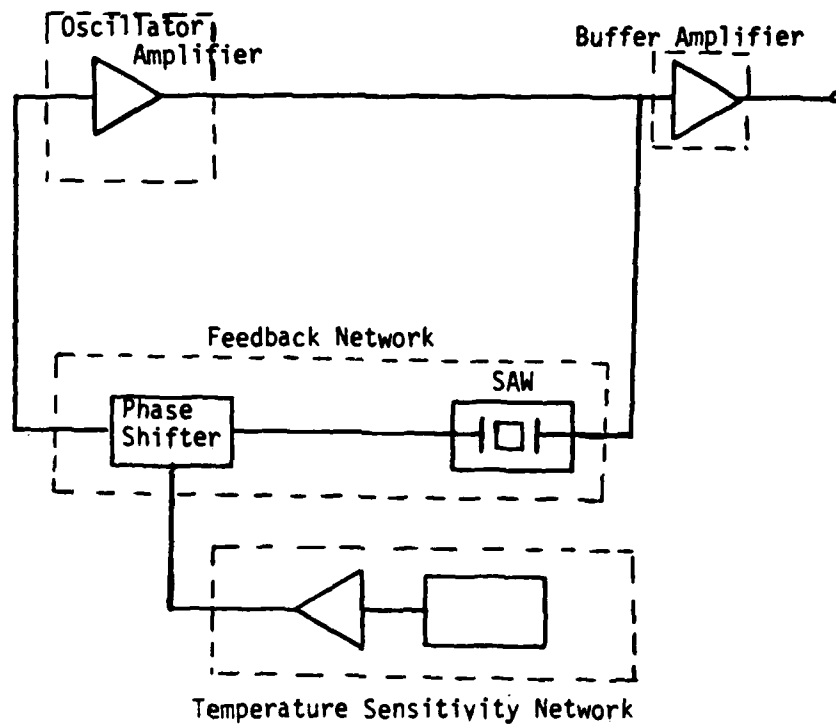

Figure 4--Block Diagram of Temperature Compensated SAW Sensor



MRDC41082.9AR

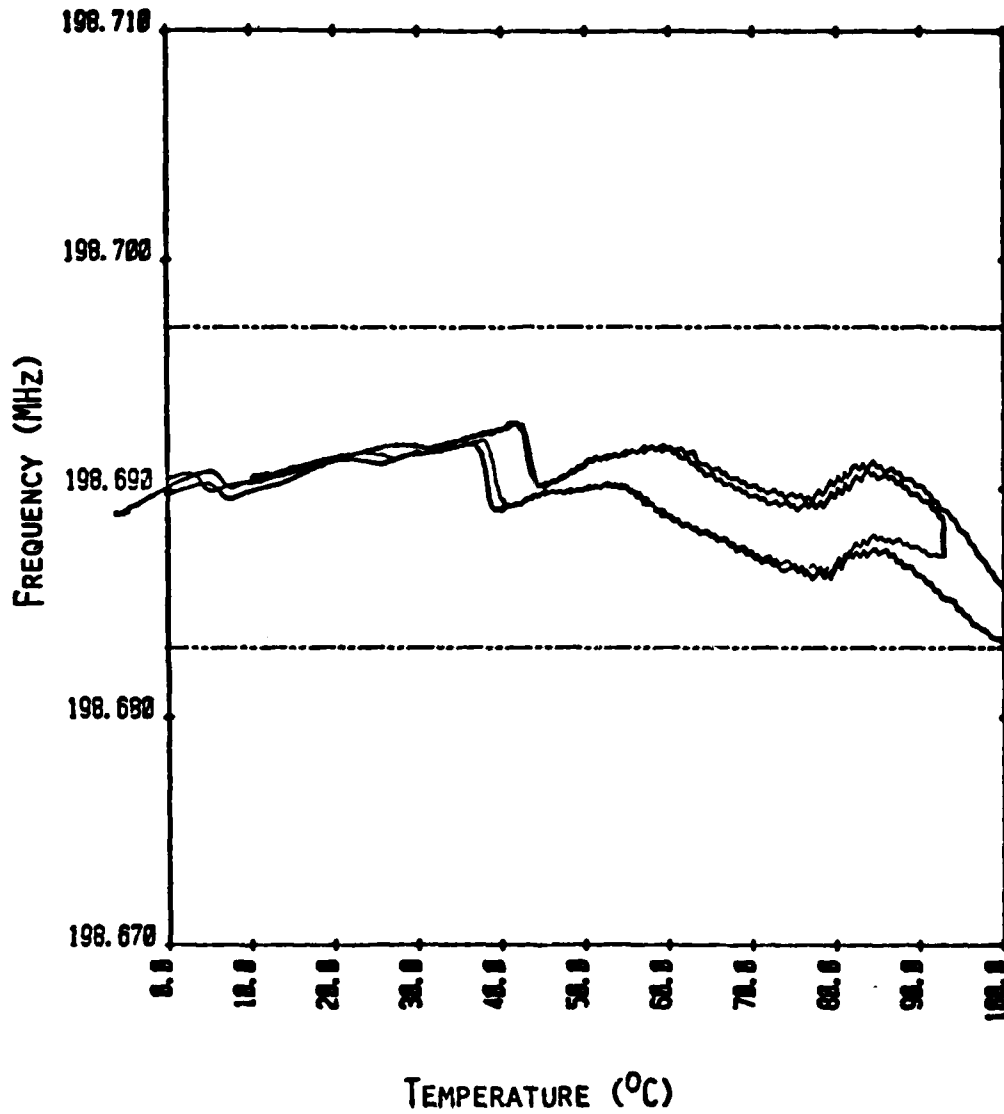

Figure 5--Frequency as a Function of Temperature for Prototype SAW Sensor



shown by the dashed limits. A sharp drop in frequency with increasing temperature at 45-50°C was due to a higher-order resonator transverse mode in the SAW two-pole crystal phase slope. Improvements in the crystal design to eliminate transverse modes and proper sealing of the crystals to eliminate hysteresis is expected to result in compensation of  $\pm 10$  ppm over the temperature range -30° to 100°C.

### 3.3 Beams of Chemical-Etched Quartz

A specific task of this project was to develop methods of machining single crystal quartz into beams for sensing acceleration. Four approaches were investigated: 1) cavitron machining; 2) sandblasting; 3) laser machining; and 4) chemical etching.

Cavitron machining and sandblasting were not able to maintain beam geometries and were abandoned after early experimentation. Laser machining was limited by heat dissipation which caused crazing and cracking of the quartz. In addition, the process was slow and not easily reproducible. Chemical etching offered the most reproducible results, however certain factors were found critical in terms of pattern replication. It was found that the surface finish of the polished quartz was important since an anisotropic etch was unavoidable on single crystal quartz wafers and the adherence of the gold film which served as the etch mask were critical to achieving good beams.



In this process, quartz wafers which were polished on both sides were coated with chrome-gold films. The chrome-gold was patterned into cantilever beam geometries using a double-sided alignment technique. After the gold had been etched, the quartz etching was performed with the gold acting as an etch mask.

Shown in the photograph of Fig. 6 are quartz accelerometer beams after etching. In this case, five beams are etched into a 1" x 1" x 0.010" quartz wafer. Each beam is in the shape of a hammer-head where the head of the beam acts as a proof-mass. The beams are connected by small un-etched bridge sections and a simple break of the connecting bridges separates the beams. After separation the beams are ready for processing of SAW resonator patterns on top and bottom surfaces of the beam. Also shown in Fig. 6 is a single beam mounted on a 16-pin dual in-line hermetic package using a teflon clamp fixture. Ceramic boards containing the hybrid oscillator circuitry (not shown in Fig. 6) are mounted on edge along both sides of the beam. After connecting the SAW resonators (on the beams) to the hybrid circuits, the entire package is sealed under vacuum using a resistance welding sealer.



Rockwell International

MRDC41082.9FR

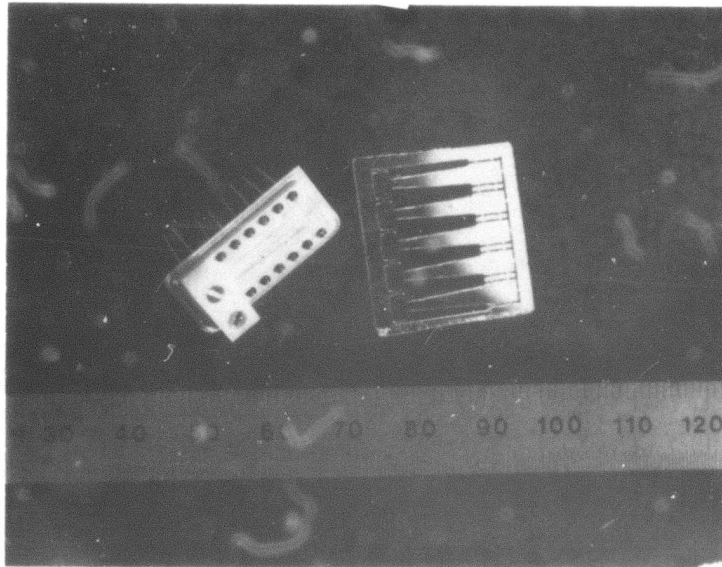

Figure 6--Photograph of 5 Hammer-Head Cantilever Beams  
and Teflon Clamp for Mounting the Cantilever Beams



#### 4.0 FUTURE PLANS

The future plan is to propose a two-year program of analysis, testing and evaluation of temperature compensated SAW accelerometer. The initial testing will evaluate the mismatch of thermal sensitivities between pairs of resonator cavities. The supporting analysis will determine the error mechanisms which cause such mismatch, and identify the changes in design or fabrication methods which would improve the temperature compensation capability. The analysis and testing of fast reaction performance will determine the transient effects from rapid temperature changes, and casual mechanisms. This information will be utilized to optimize sensor designs that minimize the sensor reaction time requirements.

The following task is an assessment of the potential for fast reaction capability in SAW accelerometers, and an indication of the important design features which most strongly influence this performance.

##### Task 1. Design, Fabricate, and Test Heaterless Sensors

The purpose of this task is to assess the feasibility of operating SAW accelerometers over a wide ambient temperature range (-55° to +71°C) without active temperature control. This task is concerned with the static sensitivities. The dynamic effects due to rapid temperature changes are considered in Task 2.



Task 1-1 Perform Design Analysis

The known temperature and strain sensitivities of SAW resonators will be used for determining the annealing and bonding requirements for achieving moderate performance requirements with paired resonators. This analysis will include the linear and quadratic effects in estimating the allowable mismatch of the "zero-sensitivity" temperature for heaterless operation over a wide temperature range. These results will be used for interpretation of the test data.

Task 1-2 Fabricate Heaterless SAW Resonator Pairs

Pairs of SAW resonators will be fabricated, mounted and packaged in hermetically sealed containers. The fabrication, mounting or packaging methods may be varied to evaluate different approaches, depending upon the results of analyses.

Task 1-3 Perform Temperature Sensitivity Tests

The objective of this test is to evaluate the mismatch of the SAW resonator central frequencies over a wide temperature range. We wish to uncouple these results from temperature sensitivities of the test electronics. Therefore, the test electronics will be outside the temperature-controlled chamber. The frequency response characteristics of the resonator cavities near the resonance peaks will be probed at several steady-state temperatures, in order to establish the mismatch characteristics versus temperature.



**Task 2. Evaluate Thermal Transient Response**

The purpose of this task is to determine the expected response of SAW accelerometers to thermal transients. These results are needed for establishing the feasibility of heaterless sensors in a fluctuating thermal environment, and for determining temperature control capabilities.

**Task 3. Fabricate and Test Resonators with Heaters**

SAW resonators will be fabricated with resistive heaters printed on the backside of the substrate. These devices will be evaluated by using the heaters to bring the substrate to ambient temperature from lower temperatures. The objective is to evaluate the fast reaction capability, without becoming deeply involved in the control aspects of the problem. A fixed heat load will be applied, and the transient response will be used as a means of determining the required stabilization time.



## 5.0 PUBLICATIONS AND PRESENTATIONS

A technical paper entitled "Inertial Guidance and Underwater Sound Detection Using SAW Sensors," was presented at the 36th Annual Symposium on Frequency Control held in Philadelphia on June 2-4, 1982. In this paper, the use of SAW sensors for inertial guidance and underwater were examined. As an accelerometer, the SAW sensor provides high accuracy, a large dynamic range ( $10^6$ ), and a digital output without using analog to digital conversion. Using relatively simple digital processing techniques, the accelerometer output can provide inertial information such as velocity and displacement. For the purpose of clarity and more detailed information, a pre-print of this paper is included as an appendix of this report.



## 6.0 REFERENCES

1. E. J. Staples, J. Wise, and A. P. Andrews, "Inertial Guidance and Underwater Sound Detection Using SAW Sensors," to be published in 36th Annual Frequency Control Symposium, U.S. Army Electronics Command, Ft. Monmouth, NJ (June, 1982).
2. J. M. Slater, "Which Accelerometers for Space Guidance?," Space/Aeronautics, October, 1960, p. 227-240.
3. G. M. Siouris, "Survey of Inertial Sensor Technology," Flugwiss Weltraumforsch, Vol. 1, No. 5, Sept.-Oct., 1977, p. 346-353.
4. W. E. Rosvold and M. L. Stephens, "Cantilever Accelerometer," AFAL-TR-77-152, WPAFB, OH, 1977.
5. P. Chen, R. S. Muller, T. Shiosaki and R. M. White, "Silicon Cantilever Beam Accelerometer Utilizing a PI-FET Capacitive Transducer," presented at the Device Research Conference, Boulder, CO, 1979.
6. J. F. Dias, H. E. Karrer, J. A. Kusters and C. A. Adams, "Frequency/Stress Sensitivity of SAW Resonators," Electronics Letters, Vol. 12, No. 22, Oct., 1976, p. 580-582.
7. J. F. Dias and H. E. Karrer, "Stress Effects on Acoustic Surface-Wave Circuits and Applications to Pressure and Force Transducers," presented at the 1975 International Solid-State Circuits Conference.
8. MIL-E-5400R, "Military Specification: Electronic Equipment, Airborne, General Specification for," 31 October 1975.

## INERTIAL GUIDANCE AND UNDERWATER SOUND DETECTION USING SAW SENSORS\*

E.J. Staples, J. Wise and A.P. Andrews

Rockwell International Microelectronics Research and Development Center  
1049 Camino Dos Rios  
Thousand Oaks, California 91360

Summary

This paper examines the use of SAW sensors for inertial guidance and underwater sound detection. In the detection of underwater sound, dynamic rather than static loading of the SAW crystal takes place resulting in information carrying sidebands in the SAW oscillator spectrum. Studies have shown that the sensitivity of prototype sensors in terms of signal-to-noise is at least equal to that of conventional hydrophones.

As an accelerometer, the SAW sensor provides high accuracy, a large dynamic range ( $10^6$ ), and a digital output without using analog-to-digital conversion. Using relatively simple digital processing techniques, the accelerometer output can provide inertial information such as velocity and displacement. Studies of the integrated error rates for SAW accelerometers have shown that they can consistently provide error rates less than a nautical mile per hour. The SAW oscillator sensor is a promising candidate for high performance, moderate cost sensor applications.

Introduction

The application of SAW sensors to underwater sound detection and inertial guidance is described in this paper. Several previous papers<sup>1-3</sup> have described the performance of SAW crystal oscillators when used to detect stress or strain as experienced in sensing the pressure applied to a quartz crystal. In the detection of underwater sound the pressure is dynamic rather than static and this results in information carrying sidebands in the SAW oscillator output spectrum. Studies<sup>4</sup> have shown that the sensitivity of SAW sensors is at least equal to conventional hydrophones with respect to signal-to-noise ratios in the low audio spectrum (0-1000 Hz).

Another useful application of SAW sensors is the detection of acceleration. In this application the SAW crystal has the advantage that it can be tailored to any shape without affecting the

resonant frequency of the resonators because the SAW frequency is independent of the bulk crystal shape. Likewise the attachment of the proof mass for fixing the scale factor of the sensor does not affect the resonant frequency of the sensor crystal.

SAW accelerometer sensors can also provide inertial information. This is accomplished by integrating the sensor output twice, once to generate velocity information, and a second time to generate displacement information. Because the SAW sensor output is a frequency proportional to acceleration, it can easily interface with digital processors without using A-to-D conversion circuitry.

SAW Sensor Fabrication

SAW resonators were photolithographically produced on polished ST-cut quartz blanks the size of which had been determined by the particular application. For underwater sound sensors the blanks were disks 0.020 x 0.550 in. in diameter and for accelerometers, bars 0.010 x 0.200 x 1.050 in. were used. The resonator electrode pattern consisted of two reflective gratings symmetrically placed on either side of a 40 finger-pair, cosine weighted interdigital transducer. The reflective gratings were fabricated using a reactive ion etch technique in a freon plasma.<sup>5</sup>

SAW sensor crystals for underwater sound detection operated at a frequency of 62 MHz, had a Q of nominally 25,000 and a series resistance of 30 ohms. SAW accelerometer sensor crystals operated at a frequency of 400 MHz, nominally had a Q of 15,000 and a series resistance of 50 ohms. Oscillator circuitry was fabricated using all hybrid chip components.<sup>6</sup> Because a single-port/single-pole resonator crystal design was used, oscillator circuitry typically required only a one transistor amplifier with nominally 3 dB of gain. This resulted in a minimum number of components, high stability, and low cost.

Static Loading Characteristics

SAW crystals operate as sensors by converting an applied strain to a frequency deviation. Application of strain by loading the crystal mechanically results in a static frequency change which is a function of the geometry of the loading fixture and the direction of applied force with

\*Work supported by Defense Advance Research Projects Agency and the Naval Air Development Center.

respect to the crystal axes. A test fixture to measure the stress sensitivity about any axis of a SAW resonator was fabricated and used to measure frequency deviation vs loading characteristics. Three types of loading, depicted in Fig. 1, were performed, (a) cantilever bending, (b) simple tension and (c) uniform diaphragm loading. The results are shown in Table I as coefficients obtained from least-squares fitting experimental data. Bending the Y'-axis of a SAW crystal produces a positive frequency shift as opposed to a negative frequency shift for bending about the X-axis. Both effects occur during uniform diaphragm loading.

Table I

Test	Measured Result
1. Cantilever, x-axis	-112 Hz/gram
2. X-axis tension	-14.8 Hz/gram
3. Cantilever, Y'-axis	+34.9 Hz/gram
4. Y'-axis tension	+0.3 Hz/gram
5. Pressure Diaphragm (compression)	+13.4 Hz/mm Hg

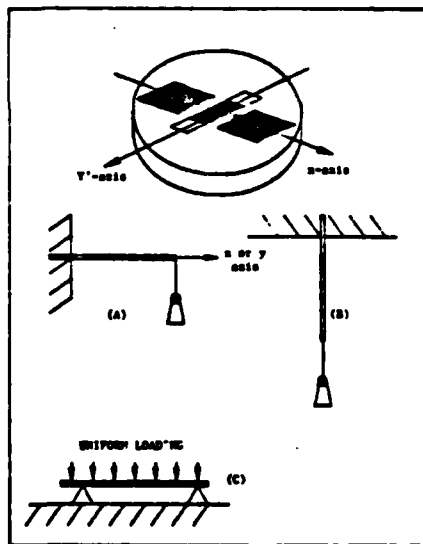

Fig. 1 Static loads applied to SAW sensor crystals; (a) cantilever bending, (b) tension, and (c) uniformly loaded diaphragm.

#### Bias Stability

Because SAW sensors operate by converting applied strain to frequency, frequency stability becomes equivalent to what is commonly termed bias stability. Bias stability, together with the full scale frequency deviation, determines the noise floor and dynamic range. Frequency stability in SAW oscillators can be expressed as a fractional

frequency distribution vs observation time (Allan variance) or as a spectral distribution (phase noise) as a function of frequency offset from the carrier. Previous studies<sup>7</sup> on many types of SAW oscillator crystals have shown that the best stability is achieved by high Q SAW resonators as opposed to SAW delay line controlled oscillators which have lower Q than resonators. Typically these oscillators have an Allan variance of  $1 \times 10^{-10}$  over measurement times 0.01 to 10 sec. Alternatively, the phase noise for a 400 MHz resonator controlled SAW oscillator is -70 dB/Hz at 10 Hz from the carrier and less than -120 dB/Hz at 1000 Hz from the carrier. For a SAW sensor with a full scale frequency deviation of 200 ppm, and a noise floor of  $1 \times 10^{-10}$ , the instantaneous dynamic range is  $2 \times 10^6$ .

In SAW sensors, bias stability is predominately controlled by long term aging and temperature stability. In practically all SAW sensor designs dual resonator crystals are used. The sensor output is the difference frequency of the two SAW oscillators which is invariant to aging and temperature to first order. Shown in Fig. 2 is the long term aging of two SAW resonators fabricated as a dual crystal. Shown in Fig. 3 is the differential aging of the two resonators. Although the absolute aging amounts to several  $\mu$ s, the differential aging is practically zero because the two resonators age together with time. In order to achieve good long term bias stability in SAW sensors,<sup>8</sup> crystal processing and packaging must be closely controlled.

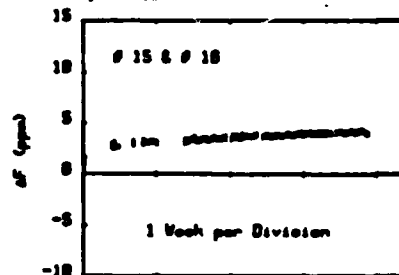

Fig. 2 Long term aging (absolute) of two SAW resonators fabricated as a dual resonator sensor crystal.

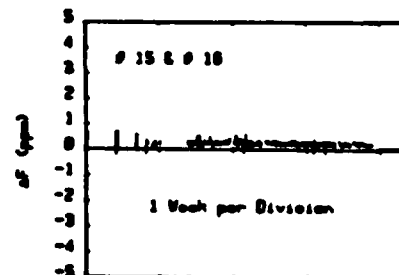

Fig. 3 Differential aging for dual resonator sensing crystal showing long term bias stability.

Sensor bias instability due to temperature can also be reduced by using dual resonator crystals. In the sensor described in this paper dual resonators fabricated on the same quartz substrate were used to control two oscillator circuits. To first order any temperature variations influenced both oscillators identically making the difference frequency invariant to temperature. Shown in Fig. 4 are histograms obtained when the temperature was varied at a constant rate from 25°C to 85°C. Because the frequency scale is in ppm both oscillators start out equal at 0 ppm, however, as the temperature rises the frequency change is not equal. The primary cause of this bias instability was found to be variations in the metallization thickness of the resonators. This in turn caused the resonators to have slightly different parabolic turning points. The same data plotted as a differential frequency is shown in Fig. 5 and shows the bias stability to be linear over the 60°C range. These results show that to compensate against temperature perfectly, closely matched pairs of resonators must be fabricated.

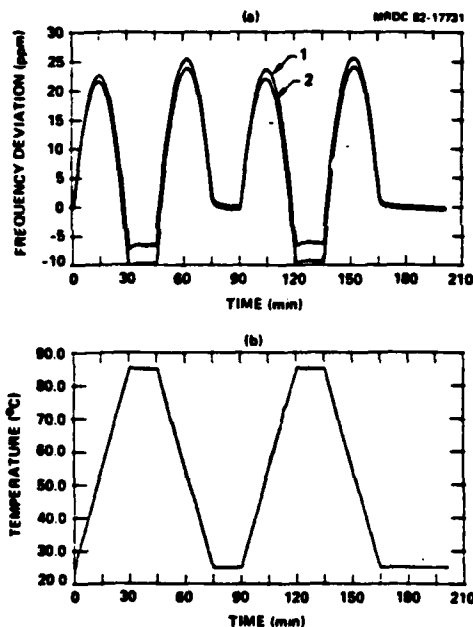

Fig. 4 Histograms showing (a) dual crystal oscillator frequencies and (b) temperature as a function of time.

#### Underwater Sound Detection

A prototype underwater sound wave detector was constructed using a cantilever beam SAW sensor. Each hydrophone contained two independent crystal oscillators and difference frequencies of 10 kHz and 125 kHz were used. Sound waves in the water were transmitted from a thin sensing diaphragm to the SAW crystal by means of a steel shaft and the sensing crystal was mounted as a cantilever beam with the bending axis perpendicular to the sagittal plane.

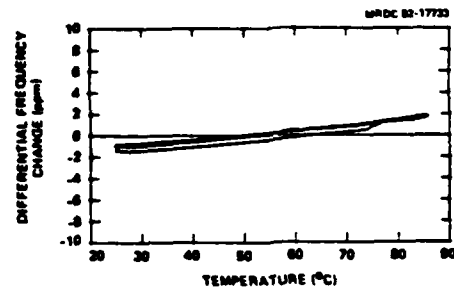

Fig. 5 Differential frequency stability or bias stability as a function of temperature, 25°C to 85°C.

Frequency modulation of the SAW oscillator produces an instantaneous frequency which is proportional to the modulating signal at frequency,  $\omega_m$ .

$$\omega_i(t) = \omega_c + \Delta\omega \cos(\omega_m t)$$

where  $\Delta\omega$  is the amplitude of the frequency deviation. Since the instantaneous frequency is defined to be the derivative of the phase, the output waveform will be given by,

$$V_o(t) = A_c \cos \left[ \omega_c t + \frac{\Delta\omega}{\omega_m} \sin \omega_m t \right]$$

The peak frequency deviation  $\Delta\omega$  is independent of  $\omega_m$ , while the peak phase deviation,  $\Delta\theta = \Delta\omega/\omega_m$ , is inversely proportional to the modulation frequency.  $\Delta\theta$  is commonly referred to as the modulation index.

The amplitude of the FM sidebands relative to the carrier can be represented by a Bessel function expansion of the signal waveform

$$V_o(t) = A_c \sum_{n=-\infty}^{\infty} J_n(\Delta\theta) \cos(\omega_c + n\omega_m)t$$

SAW hydrophones were fabricated and tested by comparing with a calibrated Naval G-19 hydrophone which had a sensitivity of -205.5 dB re 1 V/ $\mu$ Pa. In these tests the frequency spectrum or sidebands of the SAW oscillator were measured under differing conditions of irradiation by ultrasound in a water column.

An example of the data taken is shown in Fig. 6 and consists of two spectrum plots. Figure 6a is a baseband spectrum of the calibrated Navy hydrophone indicating the presence of a 100 Hz tone with an intensity level of -68.873 dBV (7 pascals). The corresponding SAW hydrophone output spectrum is shown in Fig. 6b. The SAW sensor IF was set to 10 kHz and the spectrum analysis performed about this frequency as shown.

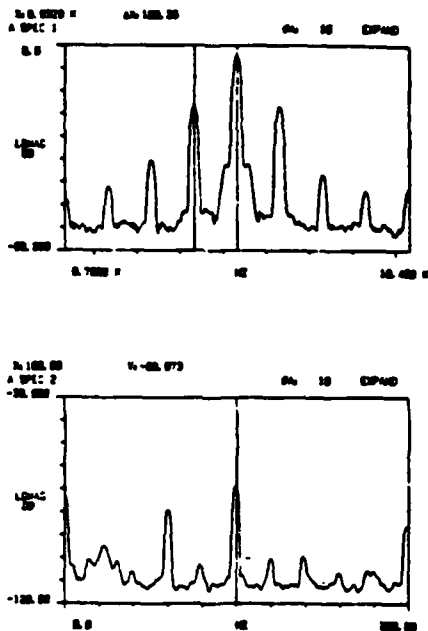

Fig. 6 SAW hydrophone output (a) compared with conventional baseband hydrophone response (b).

Sideband signal levels were measured at different frequencies by holding the intensity fixed at a level of 2 pascals. The frequency range covered was 50 to 1000 Hz. The ratio of sideband-to-carrier signal level at each modulating frequency provided a measure of the modulation index at that particular frequency. Frequency deviation was obtained by multiplying the modulation index by the modulating frequency. A plot of experimental frequency deviation vs modulating frequency is shown in Fig. 7 and a peak in the deviation occurs at approximately 300 Hz due to the mechanical resonance of the diaphragm post linkage and the sensor mounting structure. The observed frequency deviation is consistent with the device geometry and static cantilever loading.

In order to compare the sensitivity of SAW hydrophones to conventional (baseband) hydrophones the signal-to-noise ratio as a function of modulation frequency was measured under a 1 pascal irradiation. The results are listed in Table II. The SAW sensor S/N reached a high of 60 dB for low modulation frequencies and became equal to that of the calibrated phone at approximately 1000 Hz. At low modulation frequencies, < 300 Hz, the SAW hydrophone is comparable to a baseband hydrophone with a sensitivity of  $-180$  dB re 1 V/ $\mu$ Pa. The high sensitivity is a result of low phase noise in the SAW oscillator and increasing modulation index at low modulation frequencies.

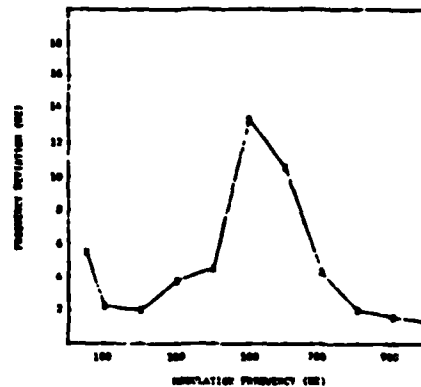

Fig. 7 Experimentally measured frequency deviation vs modulation frequency.

Table II

Modulation Frequency (Hz)	Sideband To Carrier (dB)	Modulation Index	Frequency Deviation (Hz)
50	-25.3	0.1089	5.45
100	-39.0	0.0224	2.24
200	-46.0	0.0100	2.00
300	-44.0	0.0125	3.75
400	-45.0	0.0112	4.48
500	-37.5	0.0267	13.35
600	-41.1	0.0175	10.50
700	-50.3	0.0061	4.27
800	-58.2	0.0025	2.00
900	-61.1	0.00175	1.57
1000	-63.8	0.00129	1.29

#### SAW Accelerometer - Inertial Guidance

Accelerometers are an important sensing element in many guidance systems. Modern signal processing methods dictate that the sensor be capable of interfacing with digital circuitry such as microprocessors. The SAW sensor output frequency is inherently a digital bit stream. The dual crystal SAW sensor provides a low frequency output with good bias stability. Digital interfacing in this case can be implemented with a high degree of accuracy using simple counting circuitry. For example, a 60 kHz SAW sensor output tone can be measured with 16 bit precision using two simple 8 bit counter chips in series.

A dual crystal SAW accelerometer was built and tested using quartz cantilever beams and SAW resonators operating at 400 MHz. One end was rigidly clamped and the other free with a proof mass attached. The proof mass was varied to achieve the full scale output sensitivity of 20 ppm/g. Each resonator of the dual resonator crystal was used to control the frequency of oscillator circuitry with ample shielding to prevent lock-up of the oscillators to a common frequency. The out-

puts were then mixed and the difference frequency input to an HP 5345 counter whose output was digitally processed using an HP9825 calculator.

In SAW accelerometer system applications the ability to use signal processing techniques without resort to A-to-D conversion is unique. For SAW accelerometer crystals operating at 400 MHz with a 20 ppm/g sensitivity, the digital output quantization is approximately 0.004 fps/bit. The acceleration expressed as a function of frequency deviation is

$$A = K \cdot \Delta F(t)$$

where the scale factor  $K = 2.6 \times 10^{-3}$  meter/Hz  $\cdot$  sec<sup>2</sup>. Digitally integrating the difference frequency yields velocity information,

$$V(t) = K \int \Delta F(t) dt$$

Performing a second integration reduces the data to the required displacement or inertial information,

$$X(t) = K \iint \Delta F(t) dt$$

Shown in Fig. 8 is the actual count output of a SAW accelerometer when measured with a 1 sec gate time. The difference frequency was 60 kHz which has been subtracted out and only the deviation in the difference frequency ( $\pm 1$  Hz) is shown. Summing the counts results in the velocity count ( $\pm 10$  Hz\*sec) as a function of time shown. This curve represents the area under the acceleration-frequency curve. Performing another summation as a function of time results in the curve for displacement ( $\pm 4000$  Hz\*sec<sup>2</sup>). The scale factor was 20 ppm/g or 769 Hz/m/sec<sup>2</sup>. The integrated velocity error for the 1000 sec time period shown was typically less than 0.013 m/sec and the displacement error less than 5.2 meters. As expected the integrated error is closely related to the integration time and this is dependent upon the actual mission time or time for which no other inertial guidance data is available.

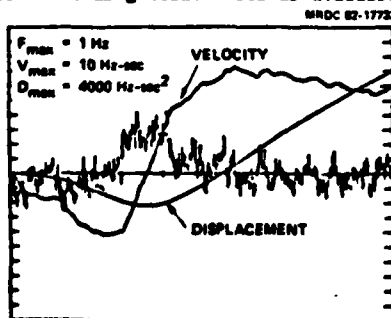

Fig. 8 Frequency output (a) from a SAW accelerometer and digitally processed velocity (b) and displacement (c) data information. (Time span = 30 min)

### Conclusions

An experimental SAW underwater sound sensor was constructed and evaluated in terms of static and dynamic loading. The results of static loading indicates that mounting of the crystal is important in order to achieve maximum sensitivity to applied loading. A SAW oscillator-sensor was configured as a hydrophone and compared in a water tank with a calibrated hydrophone. The SAW sensor was found to be comparable in sensitivity to conventional hydrophones over the frequency range 0-1000 Hz. The frequency deviation in a SAW sensor is constant and this causes an increase in the signal-to-noise ratio as the modulation frequency decreases. As a hydrophone, the SAW sensor is well suited when the frequencies of interest are in the low audio range.

SAW sensors were also tested as accelerometers for inertial guidance. Tests were performed on integrated noise levels for simulated guidance mission times. For times up to 1 hour, cumulative displacement error rates less than 20 meters/hour were achieved. This data is to be compared with typical error rates for moderately accurate accelerometers of 1 nautical mile per hour or 1851 meters per hour.

These results are encouraging and future studies will no doubt improve on the performance already demonstrated.

### References

1. T.M. Reeder, D.E. Culler and M. Gilden, "SAW Oscillator Pressure Sensors," IEEE Ultrasonics Symposium Proceedings, pp. 264-268 (1975).
2. J.F. Dias, H.E. Karrer, J.A. Kusters and C.A. Adams, "Frequency/Stress Sensitivity of SAW Resonators," Electronics Letters, 12, No. 22, pp. 580-582 (1976).
3. D.F. Weirauch, R.J. Schwartz and R.C. Bennett, "SAW Resonator Frit-Bonded Pressure Transducer," IEEE Ultrasonics Symposium Proceedings, pp. 874-877 (1979).
4. E.J. Staples, J. Wise, J.S. Schoenwald and T.C. Lim, "Surface Acoustic Wave Underwater Sound Sensors," IEEE Ultrasonics Symposium Proceedings, pp. 870-873 (1979).
5. C. Adams and J.A. Kusters, "Deeply Etched SAW Resonators," Proceedings of the 31st Annual Frequency Control Symposium, U.S. Army Electronic Command, Ft. Monmouth, New Jersey, pp. 246-250, June 1977.
6. S.J. Dolochycki, E.J. Staples, J. Wise, J.S. Schoenwald and T.C. Lim, "Hybrid SAW Oscillator Fabrication and Packaging," Proceedings of the 33rd Annual Frequency Control Symposium, U.S. Army Electronic Command, Ft. Monmouth, New Jersey, pp. 374-378, June 1979.

MRDC41082.9AR

7. E.J. Staples and T.C. Lin, "300 MHz Oscillators Using SAW Resonators and Delay Lines," Proceedings of the 31st Annual Frequency Control Symposium, U.S. Army Electronic Command, New Jersey, pp. 371-373, June 1977.

8. J.S. Schoenwald, J. Wise and E.J. Staples, "Absolute and Differential Aging of SAW Resonator Pairs," Proceedings of the 35th Annual Frequency Control Symposium, U.S. Army Electronic Command, New Jersey.