

AD-A123 051

A DECISION SUPPORT SYSTEM FOR ACQUISITION OF F-16
AVIONICS INTERMEDIATE S. (U) AIR FORCE INST OF TECH
WRIGHT-PATTERSON AFB OH SCHOOL OF SYST.

1/2

UNCLASSIFIED

G C BRYSON ET AL. SEP 82 AFIT-LSSR-11-82

F/G 1/3

NL

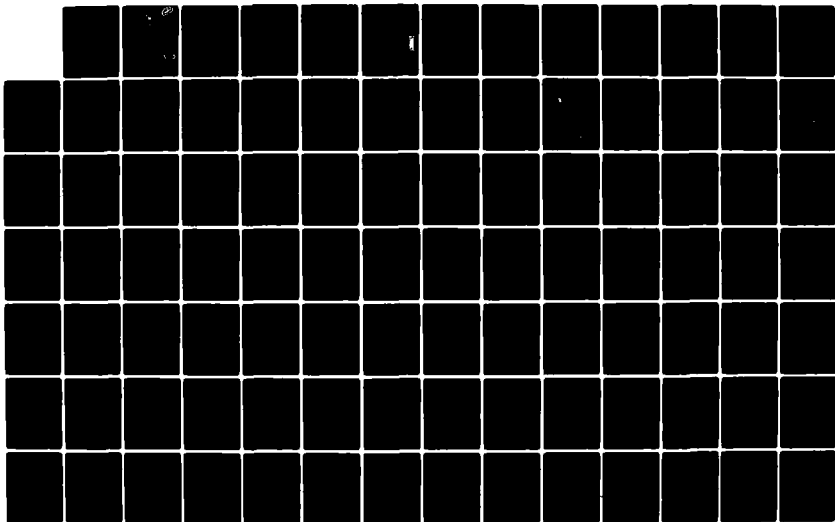

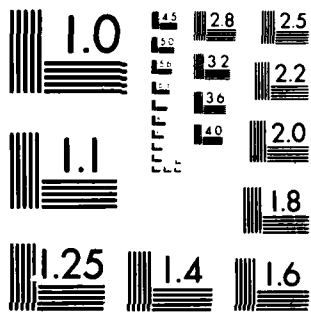

MICROCOPY RESOLUTION TEST CHART
NATIONAL BUREAU OF STANDARDS-1963-A

AD A 123051

2

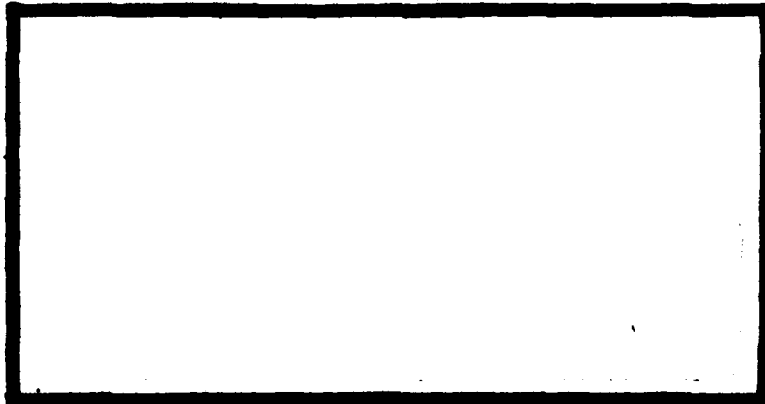

DTIC
 ELECTE
 JAN 6 1983
 S D D

DTIC FILE COPY

DEPARTMENT OF THE AIR FORCE
 AIR UNIVERSITY (ATC)
AIR FORCE INSTITUTE OF TECHNOLOGY

Wright-Patterson Air Force Base, Ohio

DISTRIBUTION STATEMENT A
 Approved for public release;
 Distribution Unlimited

88 1 5 054

Accession For	
NTIS GRA&I	<input checked="" type="checkbox"/>
DTIC TAB	<input type="checkbox"/>
Unannounced	<input type="checkbox"/>
Justification	
By _____	
Distribution/ _____	
Availability Codes	
Dist	Avail and/or Special
A	



A DECISION SUPPORT SYSTEM FOR
ACQUISITION OF F-16 AVIONICS
INTERMEDIATE SHOP TEST SETS USING THE
SYSTEM SCIENCE PARADIGM AND Q-GERT

Gary C. Bryson, First Lieutenant, USAF
David J. Husby, Captain, USAF
Michael E. Webb, Captain, USAF

LSSR 11-82

DISTRIBUTION STATEMENT A
Approved for public release;
Distribution Unlimited

The contents of the document are technically accurate, and no sensitive items, detrimental ideas, or deleterious information are contained therein. Furthermore, the views expressed in the document are those of the author(s) and do not necessarily reflect the views of the School of Systems and Logistics, the Air University, the Air Training Command, the United States Air Force, or the Department of Defense.

AFIT RESEARCH ASSESSMENT

The purpose of this questionnaire is to determine the potential for current and future applications of AFIT thesis research. Please return completed questionnaires to: AFIT/LSH, Wright-Patterson AFB, Ohio 45433.

1. Did this research contribute to a current Air Force project?

- a. Yes b. No

2. Do you believe this research topic is significant enough that it would have been researched (or contracted) by your organization or another agency if AFIT had not researched it?

- a. Yes b. No

3. The benefits of AFIT research can often be expressed by the equivalent value that your agency received by virtue of AFIT performing the research. Can you estimate what this research would have cost if it had been accomplished under contract or if it had been done in-house in terms of manpower and/or dollars?

a. Man-years _____ \$ _____ (Contract).

b. Man-years _____ \$ _____ (In-house).

4. Often it is not possible to attach equivalent dollar values to research, although the results of the research may, in fact, be important. Whether or not you were able to establish an equivalent value for this research (3 above), what is your estimate of its significance?

- a. Highly Significant b. Significant c. Slightly Significant d. Of No Significance

5. Comments:

Name and Grade

Position

Organization

Location

FOLD DOWN ON OUTSIDE - SEAL WITH TAPE

AFIT/LSH
WRIGHT-PATTERSON AFB OH 45433
OFFICIAL BUSINESS
PENALTY FOR PRIVATE USE. \$300



NO POSTAGE
NECESSARY
IF MAILED
IN THE
UNITED STATES

BUSINESS REPLY MAIL
FIRST CLASS PERMIT NO. 73236 WASHINGTON D.C.

POSTAGE WILL BE PAID BY ADDRESSEE

AFIT/DAA
Wright-Patterson AFB OH 45433



FOLD IN

UNCLASSIFIED

SECURITY CLASSIFICATION OF THIS PAGE (When Data Entered)

REPORT DOCUMENTATION PAGE		READ INSTRUCTIONS BEFORE COMPLETING FORM
1. REPORT NUMBER LSSR 11-82	2. GOVT ACCESSION NO. AD-A123051	3. RECIPIENT'S CATALOG NUMBER
4. TITLE (and Subtitle) A DECISION SUPPORT SYSTEM FOR ACQUISITION OF F-16 AVIONICS INTERMEDIATE SHOP TEST SETS USING THE SYSTEM SCIENCE PARADIGM AND Q-GERT		5. TYPE OF REPORT & PERIOD COVERED Master's Thesis
		6. PERFORMING ORG. REPORT NUMBER
7. AUTHOR(s) Gary C. Bryson, First Lieutenant, USAF David J. Husby, Captain, USAF Michael E. Webb, Captain, USAF		8. CONTRACT OR GRANT NUMBER(s)
9. PERFORMING ORGANIZATION NAME AND ADDRESS School of Systems and Logistics Air Force Institute of Technology, WPAFB OH		10. PROGRAM ELEMENT, PROJECT, TASK AREA & WORK UNIT NUMBERS
11. CONTROLLING OFFICE NAME AND ADDRESS Department of Communication and Humanities AFIT/LSH, WPARB OH 45433		12. REPORT DATE September 1982
14. MONITORING AGENCY NAME & ADDRESS (if different from Controlling Office)		13. NUMBER OF PAGES 158
		15. SECURITY CLASS. (of this report) UNCLASSIFIED
		15a. DECLASSIFICATION/DOWNGRADING SCHEDULE
16. DISTRIBUTION STATEMENT (of this Report) Approved for public release; distribution unlimited		
17. DISTRIBUTION STATEMENT (of the abstract entered in Block 20, if different from Report)		
18. SUPPLEMENTARY NOTES APPROVED FOR PUBLIC RELEASE: LAW AFR 190-17 Lynn E. Wolaver Dean for Research and Professional Development AIR FORCE INSTITUTE OF TECHNOLOGY (ATC) WRIGHT-PATTERSON AFB, OH 45433 2 SEP 1982		
19. KEY WORDS (Continue on reverse side if necessary and identify by block number) DECISION SUPPORT SYSTEM ACQUISITION OF SUPPORT EQUIPMENT F-16 REPAIR CYCLE PROCESS AVIONICS INTERMEDIATE SHOP SIMULATION SYSTEM SCIENCE PARADIGM MODELING Q-GERT		
20. ABSTRACT (Continue on reverse side if necessary and identify by block number) Thesis Chairman: Russell M. Genet, GS-14 Faculty Reader: Ronald G. Blackledge, Lieutenant Colonel, USAF		

UNCLASSIFIED

SECURITY CLASSIFICATION OF THIS PAGE(When Data Entered)

Acquisition of support equipment is an integral part of initial logistics support for new weapons systems. However, uncertainty exists as to determining how much support equipment should be acquired to effectively and efficiently support a weapons system. Although many quantitative decision support tools have been developed to assist DOD logistics managers in determining the amount of support equipment required, the authors conclude that a modified F-111 test set utilization model, with contractor-provided engineering estimated parameters, was used to determine support equipment requirements for the F-16 aircraft. Using systems theory and queueing modeling to represent the F-16 LRU repair cycle process, the authors developed a Q-GERT simulation model to act as a decision support system for use in experimenting with varying quantities of F-16 AIS test sets. After statistical analysis of F-16 real world data and simulation results, the authors conclude that a Q-GERT simulation model can be used to represent the real world F-16 LRU repair cycle. In addition, two AIS test sets will statistically significantly reduce LRU awaiting maintenance times, but three will not. However, any decision should be evaluated both quantitatively (using the Q-GERT model) and qualitatively (using the knowledge and experience of the decision maker).

UNCLASSIFIED

SECURITY CLASSIFICATION OF THIS PAGE(When Data Entered)

LSSR 11-82

A DECISION SUPPORT SYSTEM FOR ACQUISITION OF F-16
AVIONICS INTERMEDIATE SHOP TEST SETS USING
THE SYSTEM SCIENCE PARADIGM AND Q-GERT

A Thesis

Presented to the Faculty of the School of Systems and Logistics
of the Air Force Institute of Technology

Air University

In Partial Fulfillment of the Requirements for the
Degree of Master of Science in Logistics Management

By

Gary C. Bryson, BS
First Lieutenant, USAF

David J. Husby, BS
Captain, USAF

Michael E. Webb, BS
Captain, USAF

September 1982

Approved for public release;
distribution unlimited

This thesis, written by

First Lieutenant Gary C. Bryson

Captain David J. Husby

and

Captain Michael E. Webb

has been accepted by the undersigned on behalf of the
faculty of the School of Systems and Logistics in partial
fulfillment of the requirements for the degree of

MASTER OF SCIENCE IN LOGISTICS MANAGEMENT

DATE: 29 September 1982

COMMITTEE CHAIRMAN

FACULTY READER

ACKNOWLEDGEMENTS

The authors wish to express their sincere thanks to their wives: Jayme Bryson, Katherine Husby, and Michele Webb, and children Stewart Bryson and Jon Husby, for their support and long hours of patience. Without their understanding, this thesis could not have been completed.

We also wish to thank our thesis advisor, Mr. Russell M. Genet, and our faculty reader, Lieutenant Colonel Ronald G. Blackledge, for their assistance and encouragement throughout this endeavor.

Finally, we would like to express our appreciation to our typist, Phyllis Reynolds, who transformed a rough product into a finished, professional report.

TABLE OF CONTENTS

	Page
ACKNOWLEDGEMENTS	iii
LIST OF TABLES	ix
LIST OF FIGURES	x
Chapter	
I. INTRODUCTION	1
Background: Electronics, Computers, Technology, and Automatic Test Equipment	1
F-16 Maintenance Concepts: Organizational, Intermediate, Depot	8
Problem Statement: Determining Support Equipment Requirements	10
Theory Postulation	17
Research Question #1: Character- ization of Arrival and Service Random Variables	17
Research Question #2: Relationship Between AIS Test Sets and LRU Waiting Time	18
Research Question #3: The Practical Significance Issue	20
Summary	20
II. RESEARCH METHODOLOGY	22
Introduction	22
The Queueing System	22
Q-GERT System	23

Chapter	Page
Scope/Limitations: The F-16 Ultra-High Frequency Receiver/Transmitter and Waiting Time	25
Data Collection Plan	26
CDS Data Collection System	29
LRU Data Collection	31
Data Analysis Plan: Application of Statistical Analysis	31
Analysis of Results Plan: Validation and Statistical Testing	33
Theory Testing Methodology	34
Research Question #1: Character- ization of Arrival and Service Random Variables	34
Research Question #2: Relationship Between AIS Test Sets and LRU Waiting Time	35
Research Question #3: The Practical Significance Issue	35
Summary	36
III. FINDINGS	38
Introduction: The System Science Paradigm Implemented	38
Step I. Conceptualization	39
Purpose: Modeling the Real World	39
Structural Model: A Causal-Loop Diagram	40
Step II. Analysis and Measurement	42
Parametric Model: The Structural Model Quantified	42
System Definition: The F-16 LRU Repair Cycle	48

Chapter	Page
The Q-GERT Model	49
Experimental Design: Treatments and Observations	54
Step III. Computerization	56
Computer Listing	56
Model Experimentation	57
Simulation Output	58
Findings and Their Relevance to Research Questions	61
Research Question #1: Character- ization of Arrival and Service Random Variables	61
Research Question #2: Relationship Between AIS Test Sets and LRU Waiting Time	62
Research Question #3: The Practical Significance Issue	63
Summary	64
IV. CONCLUSIONS AND RECOMMENDATIONS	66
Introduction	66
Conclusions	67
Research Question #1: Character- ization of Arrival and Service Random Variables	67
Research Question #2: Relationship Between AIS Test Sets and LRU Waiting Time	68
Research Question #3: The Practical Significance Issue	69

Chapter	Page
Recommendations	71
Research Question #1: Character- ization of Arrival and Service Random Variables	71
Research Question #2: Relationship Between AIS Test Sets and LRU Waiting Time	71
Research Question #3: The Practical Significance Issue	72
Review of Conclusions and Recommendations . .	72
Additional Research Requirements	76
Summary	77
APPENDICES	80
A. ABBREVIATIONS, ACRONYMS, AND SYMBOLOGY	81
B. F-16 SYSTEMS PROGRAM OFFICE MAINTENANCE DATA .	87
C. FAILURE RATE DATA	92
D. CONDESCRIPTIVE STATISTICS OF FAILURE DATA . . .	95
E. CONDESCRIPTIVE STATISTICS, HISTOGRAMS, AND GOODNESS-OF-FIT TESTS	97
E1. INTERARRIVAL TIME CONDESCRIPTIVE STATISTICS AND HISTOGRAM	99
E2. CONDESCRIPTIVE STATISTICS, HISTOGRAM, AND GOODNESS-OF-FIT TESTS FOR TIME-TO-TEST RANDOM VARIABLE	101
E3. CONDESCRIPTIVE STATISTICS, HISTOGRAM, AND GOODNESS-OF-FIT TESTS FOR TIME-TO-REPAIR RANDOM VARIABLE	104
F. Q-GERT SIMULATION MODEL PROGRAM	107
G. Q-GERT TRACE	110

	Page
H. GOODNESS-OF-FIT TESTS AND A HISTOGRAM	115
H1. LILLIEFORS TEST OF Q-GERT GENERATED DEPOT MAINTENANCE TIMES	117
H2. LILLIEFORS TEST OF Q-GERT GENERATED AIS REPAIR TIMES	119
H3. LILLIEFORS TEST OF Q-GERT GENERATED AIS TEST TIMES	121
H4. KOLMOGOROV-SMIRNOV GOODNESS-OF-FIT TEST OF THE Q-GERT GENERATED UNIFORM DISTRIBUTION	123
H5. HISTOGRAM OF EXPONENTIAL DISTRIBUTION OF INTERARRIVAL TIMES	125
I. Q-GERT GENERATED RESPONSE SURFACES	127
J. ANALYSIS OF VARIANCE OF RESPONSE SURFACE	130
J1. ANALYSIS OF VARIANCE AND DUNCAN'S MULTIPLE RANGE TEST OF RESPONSE SURFACE	132
J2. KRUSKAL-WALLIS ANALYSIS OF VARIANCE OF RESPONSE SURFACE	134
J3. ONE-WAY ANALYSIS OF VARIANCE OF RESPONSE SURFACE	136
SELECTED BIBLIOGRAPHY	138
A. REFERENCES CITED	139
B. RELATED SOURCES	143

LIST OF TABLES

Table	Page
1. Correlation of Problem Statements and Research Questions	21
2. Correlation of Research Question and Methodologies	36
3. Interarrival Time Data	44
4. Test and Repair Times	46
5. Model Parameters	50
6. Model Variables	55
7. Response Surface	59
8. Effect of Change in AIS Test Sets on LRU Average Waiting Time	61
9. Correlation of Research Questions and Findings	65
10. Correlation of Research Questions and Conclusions	73
11. Correlation of Research Questions and Recommendations	75

LIST OF FIGURES

Figure	Page
1. The Four Types of Test Stations	5
2. The F-16 AIS RF Test Station	6
3. F-16 AIS Maintenance Concept	9
4. The Framework for Viewing Waiting Line Situations	11
5. F-16 System Maintenance Repair Cycle	12
6. Methodology Cones of Resolution	27
7. Equipment Cones of Resolution	28
8. Detailed Methodology Flowchart	37
9. Structural Model of Intermediate-Level LRU Maintenance	41
10. GERT Model to Generate Interarrival Times	43
11. Q-GERT Simulation Model of LRU Maintenance	51

CHAPTER I

INTRODUCTION

Background: Electronics, Computers, Technology, and Automatic Test Equipment

The Air Force's heavy reliance on electronics in almost every primary and support mission area dictates a need for effective acquisition of electronics equipment. Since approximately a third of the total value of Air Force weapons and equipment represents electronics, an effective electronics equipment acquisition program is further justified (24:38). In addition, the total fiscal 1982 requested funding of \$270 million for electronics research, development, test and evaluation (which is more money than requested for research, development, test and evaluation of weaponry, flight vehicles, or propulsion and power) underscores the importance of effective electronics equipment acquisition in the Air Force (24:38).

One of the largest applications of electronics in the Air Force is the computer. In today's world of high technology, computers are playing an ever-increasing role of importance. Within the Department of Defense (DOD), the highly complex role of the military requires

increasing use of computers to do the job of defense more efficiently (42:1-F).

The United States is entering a period of military buildup aimed at improving electronics and computer capabilities. President Reagan promises to counter Soviet military might through an accelerated five-year defense spending program that will have an increasing portion of the budget dedicated to new technologies in electronics (11:88).

One of these new technologies is the F-16 fighter aircraft, currently in the deployment stage of the acquisition cycle (29). The F-16 is a highly technical, computerized aircraft that is designed to accomplish one part of the defense mission. The Air Force has three continental United States (CONUS) bases at which the F-16 aircraft is assigned. Each base/wing has a squadron, or multiple squadrons, of F-16 aircraft assigned to an operational role. It is imperative that these aircraft be kept in the highest possible state of readiness.

While the F-16 aircraft illustrates the application of new technology in the primary mission area of the Air Force, the combination of electronics and computers in the support mission area is exemplified by automatic test equipment (ATE). Automatic test equipment is defined as

. . . equipment which carries out a predetermined program of testing for possible malfunction without reliance upon human intervention. . . . ATE is a generic term for equipment (separate or built in) satisficing a test function (diagnostic or condition indicating) and possessing an automatic capability. In this sense, ATE can be either a part of the mission equipment or a part of SE [37:80].

Although the number of electronics systems (including ATE) and associated expenditure of funds are noteworthy, General Marsh, Commander of Air Force Systems Command, states that the toughest challenges in the Air Force's electronics future are, in fact, managerial (24:38). As such, support equipment (SE), of which ATE is a major part, was identified as one of the key elements to be managed in the integrated logistics support (ILS) system (7:206). The DOD states that

Integrated logistics support is a unified and iterative approach to the management and technical activities necessary to: (a) cause support considerations to influence requirements and design; (b) define each other; (c) acquire the required support; and (d) provide the required support during the operational phase at minimum cost [7:201].

The purpose of the SE element of ILS is to ensure that the required equipment is available to operating, maintenance, and training activities when needed.

The ability of an activity to perform required maintenance depends on the availability and performance of the SE identified or developed for the prime system and equipment [7:206].

Thus, the increasing number of electronics and computer systems in the Air Force, the managerial issues raised by senior Air Force leadership, and the

identification of SE (and its subset, ATE) as a key element of integrated logistics support all point to the need for an effective and efficient decision-making system to use when procuring automatic test equipment.

In particular, one of the prime factors in maintaining a high state of readiness of the F-16 is maintenance of the aircraft and its support systems. As the F-16 was developed and produced, automatic test equipment (ATE) was also developed and produced to test and diagnose line replaceable unit (LRU) malfunctions. The ATE for the F-16 includes avionics stations for four of the major subsystems on the aircraft: radio-frequency (RF), pneumatic processor (PP), computers/inertial (CI), and display/indicators (DI) (see Figure 1) (16). Of the four subsystems listed, the RF subsystem has historically experienced the most failures (31). Figure 2 shows the Avionics Intermediate Shop (AIS) RF test station used to perform intermediate level test and repair on F-16 RF LRUs (17:1-0).

One area of concern during the acquisition of the weapon system and associated support equipment is the number of Avionics Intermediate Shop (AIS) test sets that are required to maintain the aircraft systems. Such concern manifests itself in the complex interrelationships between the costs and benefits of buying additional support equipment (SE) or spares. Essentially, the support

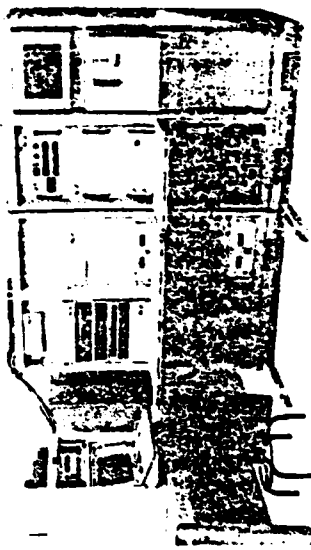

DISPLAYS/INDICATORS (D/I)
TEST STATION



COMPUTERS/INERTIAL (C/I)
TEST STATION

STATION ORIENTED

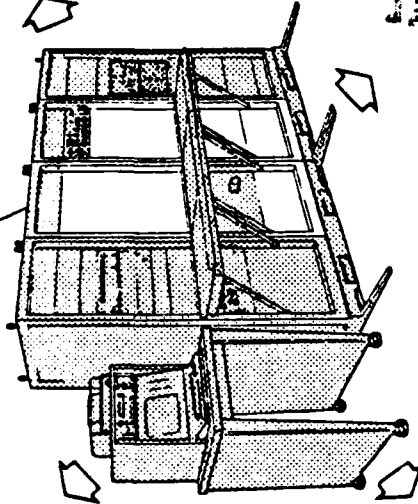

COMMON EQUIPMENT
APPEAR AS SHADED
AREAS

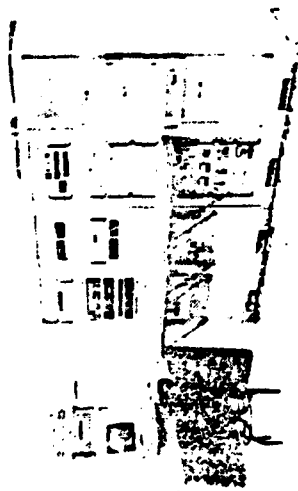

RADIO FREQUENCY (RF)
TEST STATION

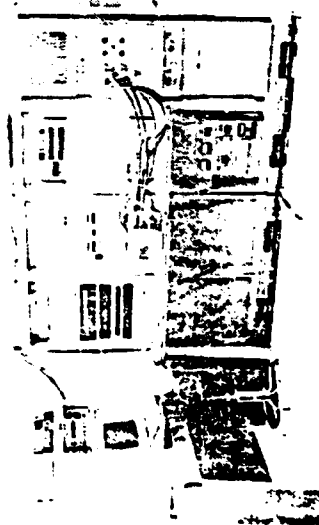

PNEUMATICS/PROCESSORS (P/P)
TEST STATION

Fig. 1. The Four Types of Test Stations

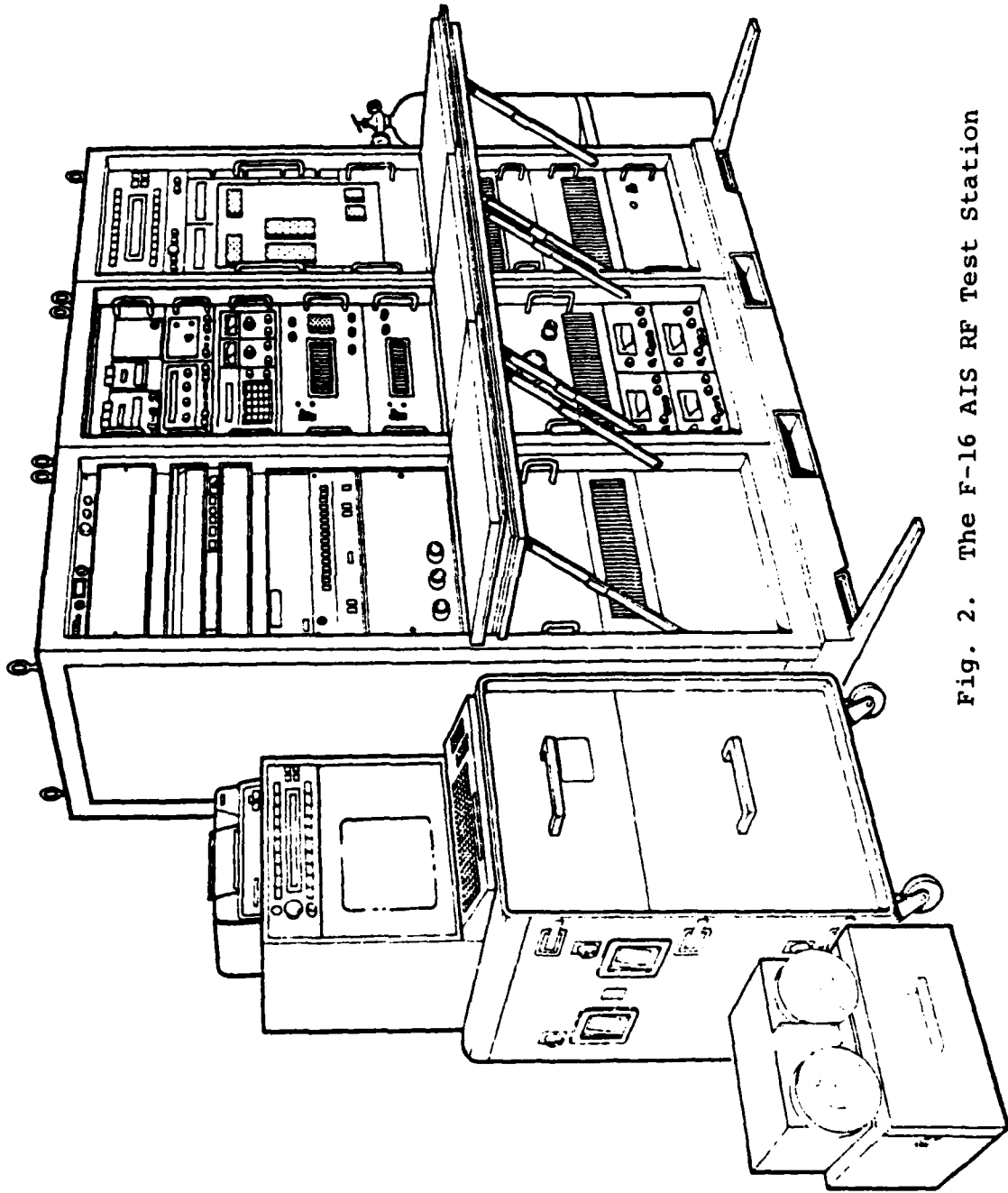

Fig. 2. The F-16 AIS RF Test Station

equipment acquisition decision is reduced to a tradeoff between the cost of an additional test set and the benefits obtained.

When buying a new weapon system and associated support equipment, a request for proposal (RFP) is normally written. The RFP usually contains explicit design or performance specifications (29).

When the F-16 was early in the acquisition cycle, it was decided that the requirement for support equipment would be included in the RFP for the complete weapon system. A RFP for the AIS-ATE was not prepared by the Air Force (5:4-5; 6). Instead, a support equipment requirements document was developed which tasked the F-16 contractor, General Dynamics-Fort Worth, to develop a RFP for F-16 support equipment. As a result of a F-16 trade study and proposals from several vendors, the current AIS-ATE configuration was recommended by General Dynamics and approved by the Air Force.

After the AIS-ATE configuration was approved, the question of how many AIS test sets to procure was addressed. A F-111 test set utilization model was modified and used to determine AIS test set quantities to support the F-16. Model parameters were estimated by engineering studies based on predicted failure rates and service times (35).

F-16 Maintenance Concepts: Organizational,
Intermediate, Depot

The F-16 is supported by a three-level maintenance concept consisting of organizational intermediate, and depot as shown in Figure 3 (17; 40; 41).

Organizational level maintenance is accomplished on a flight line and consists of fault isolation, removal, and replacement of faulty LRUs. Intermediate level maintenance is at the AIS and consists of testing, troubleshooting, and repair of LRUs using the automated test sets. The LRUs that are not, or cannot be, repaired at the intermediate level are evacuated to depot and are repaired, condemned, or salvaged.

The basic component of repair of the F-16, then, is the LRU which is defined as

. . . an item that is normally removed and replaced as a single unit to correct a deficiency or malfunction on a weapon or support system and item of equipment. Such items have a distinctive stock number for which spares are locally authorized to support the removal and replacement action [37:393].

A LRU may also be

. . . any assembly which can be removed as a unit from the system at the operating location. This may include avionics, hydraulics, pneumatics, and other recoverable parts [37:393].

Since maintenance becomes part of the pipeline for serviceable spares (4:165-195; 25; 38:pp.5-1 to 5-8, 9-1 to 9-33), the time spent in maintenance will be a driving factor in determining not only the number of

• THE F-16 AIRCRAFT UTILIZES THE STANDARD 3 LEVEL MAINTENANCE CONCEPT

ORGANIZATIONAL

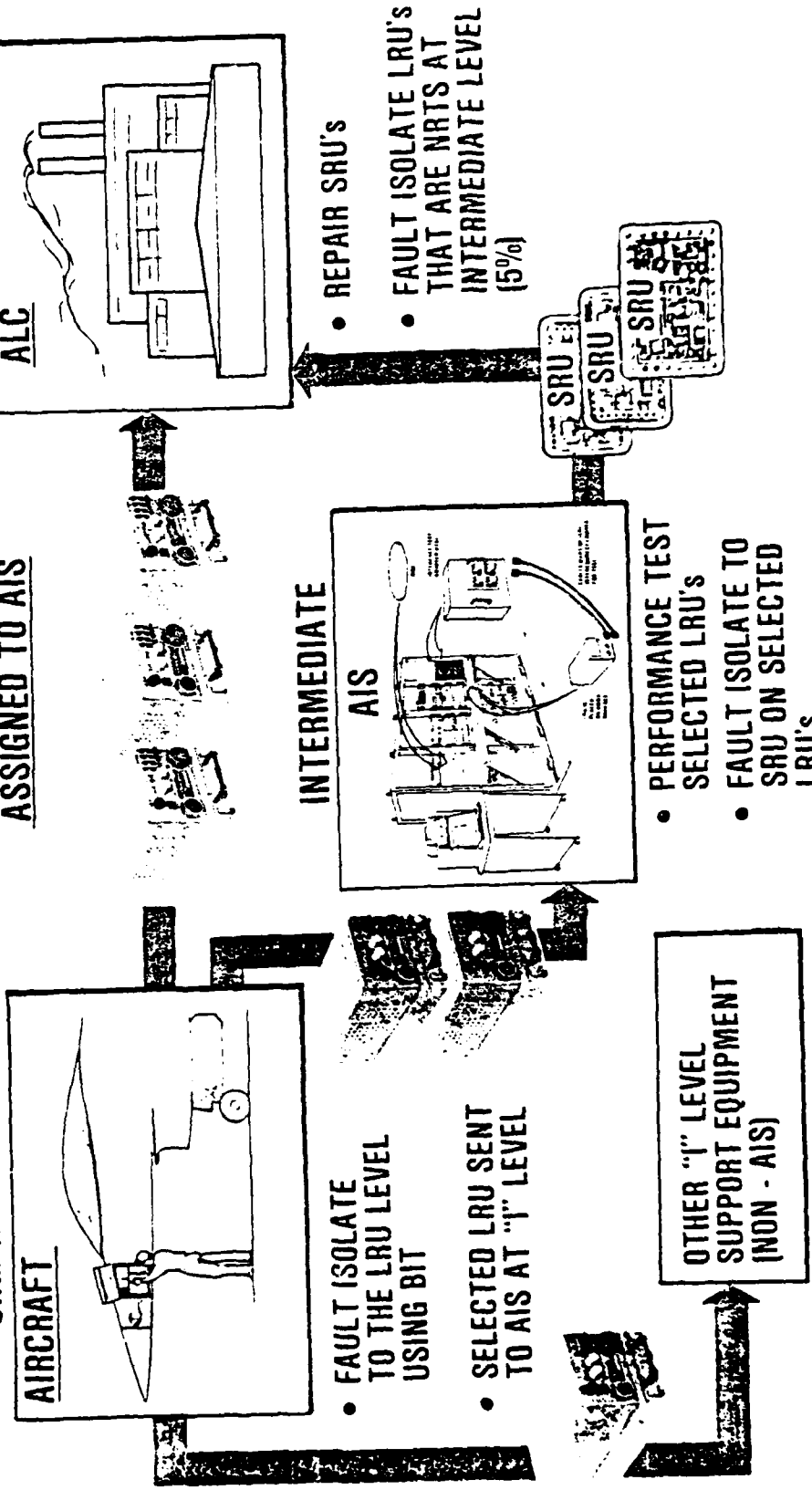

Fig. 3. F-16 AIS Maintenance Concept

spares to buy, but how many test stations are needed to efficiently move the repairable LRUs through maintenance.

Maintenance can, therefore, be viewed as a system of queues, or waiting lines, in front of servers. This view of maintenance suggests that one significant factor in deciding how many test sets to buy is waiting time in the queue.

If waiting time can be significantly reduced with additional test sets available, then that number of test sets should become part of the total weapon system acquisition.

Problem Statement: Determining Support
Equipment Requirements

The final decision to procure two AIS test sets for each group of 72 F-16 aircraft and additional test sets for the depot appears to have been determined by using a modified F-111 test set utilization model. Apparently there were no unique F-16 models of real world operational data used to calculate the number of ATE-AIS sets that would be needed to support the F-16 program because the support equipment decision was made before the data was available. The F-16 SPO director for AIS acquisition logistics, Colonel John K. Rutledge, stated that the use of a support equipment decision model using real world documented data would now be appropriate (35). In addition, the development of a unique F-16 model for test set determination and a comparison of its results against the modified F-111

model used to make the test set quantity decision could prove valuable.

Many quantitative techniques or models could be used to assist decision makers in determining the amount of support equipment (SE) required to support a new weapon system (1; 2; 4; 8; 21; 25; 32; 36; 39). In particular, queueing theory has been shown to be a valuable quantitative tool in the evaluation of the repair cycle for weapon systems and equipment (1:598-623; 8:245-261; 32:VII-X,18).

Queueing, or waiting line, situations arise whenever arrivals at a service activity desire similar services or the same server. Within the repair cycle of the F-16 LRUs, arrivals can be generated by the failure rate of the LRU and service can be represented by the time to test and/or repair the LRU. Figure 4 shows the framework for viewing waiting line situations (8:2.7). Figure 5 shows the F-16 LRU repair cycle process as depicted within the waiting line situation framework of Figure 4.

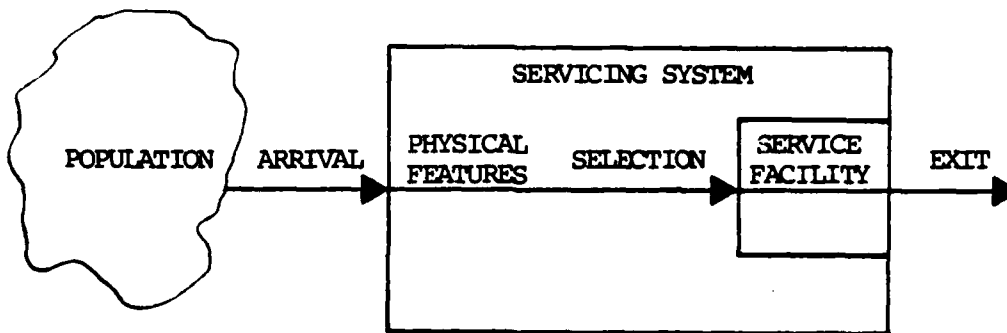

Fig. 4. The Framework for Viewing Waiting Line Situations

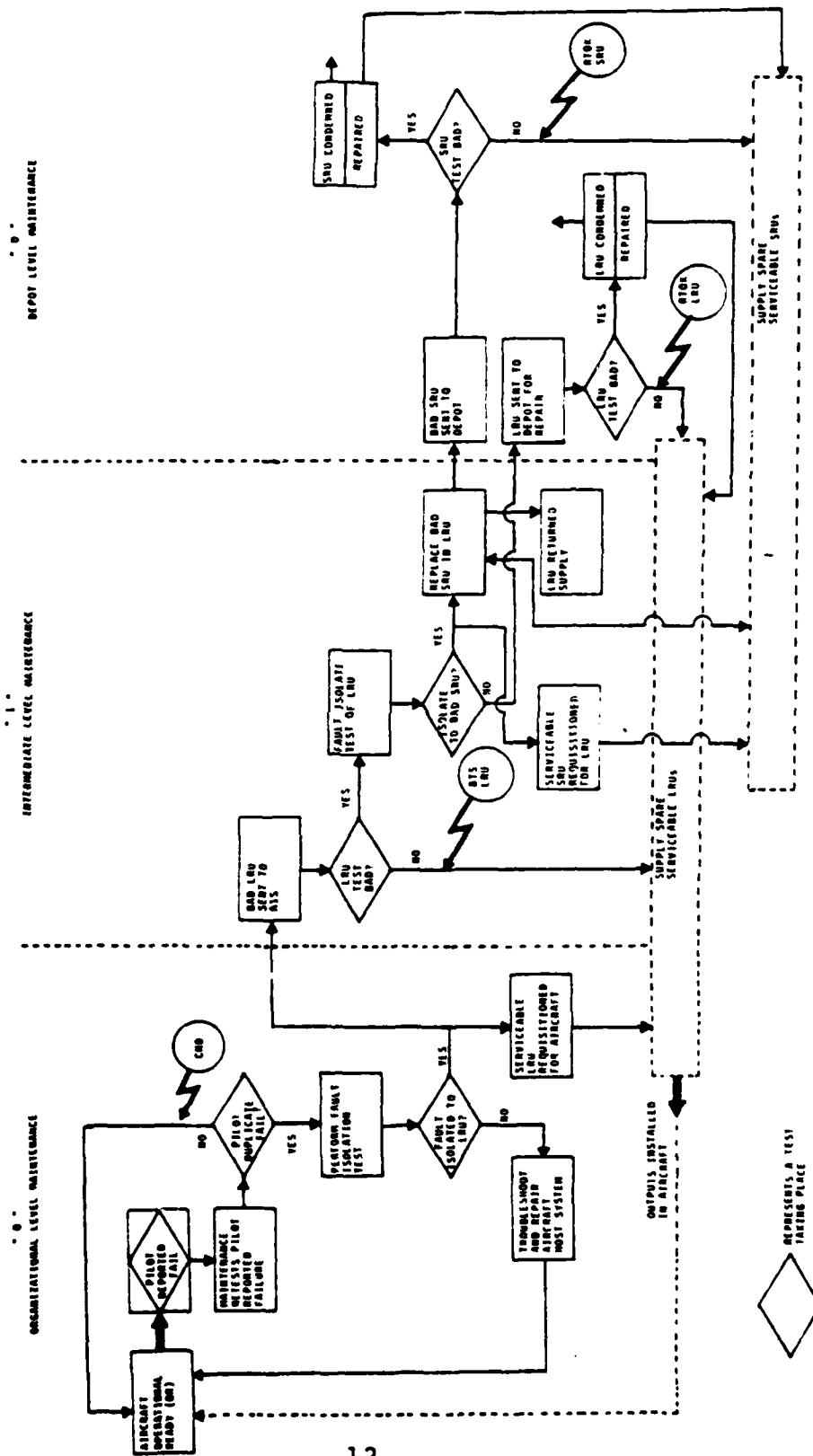

Fig. 5. F-16 System Maintenance Repair Cycle

The F-16 repair cycle can be viewed as a waiting line problem in which LRUs fail and subsequently arrive at the AIS for service. Service is then performed using the ATE-AIS equipment. Queueing models have been developed which provide information regarding waiting time, idle time, number of LRUs waiting, and other system operating characteristics (1:617). Inherent in queueing theory is a system of arrivals, queues, servers, and exit from, or return to, the system. Thus, the use of a systems approach, such as the system science paradigm, is an appropriate methodology when considering waiting line problems as in the F-16 LRU repair cycle (9; 33).

The system science paradigm has been advocated as a methodology to use when undertaking a systems analysis of an organization (36:295). The methodology of the system science paradigm consists of the steps: (1) conceptualization, (2) analysis and measurement, and (3) computerization (36:296). The system science paradigm, then, provides a way of thinking for problem solvers to use when analyzing complex systems. It provides a framework in which the researcher can organize a scientific approach to system problem solving. When using the system science paradigm, it is important to identify the elements and their interrelationships within the system. In a queueing situation the major elements are arrivals, queues, and servers. Therefore, it is important to characterize the arrival and

server random variables. In the F-16 LRU repair cycle, arrivals of the failed LRUs can be characterized by the failure rate probability distribution of the LRUs and service can be characterized by the time to test and/or time to repair probability distributions of the LRUs. Additionally, average waiting time for service is considered to be an important queueing system characteristic (1:598-599; 18).

Although there are numerous factors that could be used to determine the number of test sets needed to support the F-16 (e.g., test set utilization (4:167-168), sortie rates (23:4), cost-benefit analysis (2:292-285; 14)), queueing theory allows average waiting time for test or repair to be characterized. Average waiting time can therefore be considered a reasonable driver that will determine the appropriate number of test sets because a change in the number of test sets will affect the service activity.

Also, a F-16 LRU can be in several states of serviceability. First, it can be serviceable either installed on the end item, in transit, or in stock. Second, it can be in an unserviceable condition either awaiting maintenance, in transit, or in maintenance. Of all these conditions, the least acceptable is awaiting maintenance because it represents an asset that is not useable and no action is being taken to restore it to a

useable condition. In addition, the practical limitations imposed by the current F-16 data collection system directed the effort to an examination of the problem within the framework of waiting line modeling.

In sum, theoretical queueing models, Air Force asset policy and real world data limitations all tend to focus on average waiting time as a critical variable when making support equipment procurement decisions.

Thus, if a model can be developed which will allow determination of waiting time in the AIS, then, by varying the number of test sets, the impact on waiting time can be ascertained. As a result, a "satisficing" number of test sets can be found that will significantly reduce waiting time in the AIS.

The "satisficing" view of decision making is "an attempt to move closer to reality and to understand the world as it actually is [21:65]." Simon summarized the main assumptions of the theory of satisficing by stating that:

In the real world we usually do not have a choice between satisfactory and optimal solutions, for we only rarely have a method of finding the optimum. . . . We cannot, within practical computational limits, generate all the admissible alternatives and compare their relative merits. Nor can we recognize the best alternative, even if we are fortunate to generate it early, until we have seen all of them. We satisfice by looking for alternatives in such a way that we can generally find an acceptable one after only moderate search [21:66].

Since maintenance becomes part of the pipeline for serviceable spares, the time spent awaiting maintenance will be a driving factor in determining not only the number of spares to buy, but also how many test stations are needed to efficiently move the reparable LRUs through maintenance. Figure 5 shows the overall repair cycle for the F-16 LRUs, and is the basic building block of the structural model that will be used in modeling waiting time (31).

If waiting time can be statistically significantly reduced with additional test stations, then that number of test stations should be considered as a basis for beginning the decision process. The ultimate decision must be made within the framework of the decision maker's knowledge and experience coupled with the organizational reality of the decision setting.

In order to develop a quantitative decision support system (DSS), a data collection system that will provide raw data showing maintenance test times, actual maintenance times, and failure rates of the LRUs is needed. This data is necessary so that the failure rate parameters and probability density functions for time to test and time to repair the LRU can be ascertained.

The Dynamics Research Corporation (DRC) has provided such a system, called the Centralized Data System (CDS), for the F-16 (13:p.1-1). The CDS collects data on a real-time basis from each maintenance activity and

stores the data in a centralized computer. The stored data can be accessed by any user in the network. Data collection techniques, and the CDS network, are discussed in more detail in Chapter II (13:2-6).

Theory Postulation

In order to determine if a significant reduction in AIS waiting time has occurred when an additional test station is added, statistical comparative techniques must be used (10:40-69; 20:220-240,305-310; 26:459-524). The results of any model must be statistically tested and analyzed to determine if, within a given confidence level, a significant change in the response surface has occurred when different treatments are applied. Practical significance must also be considered when making the final decision.

Research Question #1: Characterization of Arrival and Service Random Variables

The arrival and service random variables will be used as inputs into the queueing system model of the F-16 LRU repair cycle. The arrival rate random variable can be described by the failure rate of the LRU. That is, as LRUs fail, they arrive at the Avionics Intermediate Shop for service. Service, on the other hand, can occur at the AIS in one of two ways. First, service can be performed by testing the LRU in order to isolate the reported

failure. In some cases no failure will be detected and the entire service time will consist of the time to test the LRU. Second, service can be performed by testing and repairing the LRU. In this case, a failure was detected during testing of the LRU and was subsequently repaired. Thus the service random variable can be described by the time to test and time to repair random variables of the F-16 LRU repair cycle. Therefore, the first research question is: can probability distributions and descriptive parameters for failure rates, time to test, and time to repair random variables for a selected F-16 LRU be estimated and used as inputs to the queueing simulation model?

Research Question #2: Relationship
Between AIS Test Sets and LRU
Waiting Time

While research question #1 dealt with the inputs into the queueing model of the F-16 LRU repair cycle, research question #2 postulates a theory about the outputs of the model. When a LRU arrives at the AIS for service, the LRU may immediately move into the server, or the LRU may have to wait for service. The capability of a LRU to be immediately served or having to wait for service depends upon the availability of the server. The server consists of both the personnel performing the service and the equipment which is being used to perform the service.

In the F-16 LRU repair cycle, the server's equipment is automatic test equipment. Assuming that the people are available, the only time that a LRU would be required to wait for service would be when the automatic test equipment was not available. ATE could be unavailable due to one of two reasons. First, the ATE could be in use servicing another LRU. Second, the ATE could be inoperable. Since the operational availability rate of the ATE has historically been high (31), it is assumed that the LRU will wait for service only when the ATE is being used to service another LRU. Thus, there appears to be a relationship between the number of AIS test sets and the time that a LRU spends awaiting maintenance. Therefore, the second research question is: can the effect of the number of AIS test sets on LRU waiting maintenance time be ascertained by using a queueing simulation model of the F-16 LRU repair cycle? Furthermore, does a relationship between the number of AIS test sets and LRU awaiting maintenance time exist? In other words, is the average waiting time of a LRU in the AIS independent of the number of AIS test sets? If the answer to this question is affirmative, procurement of more than one AIS test set to maintain F-16 LRUs will not significantly reduce LRU awaiting maintenance time.

Research Question #3: The Practical Significance Issue

Research question #1 theorized that model inputs could be characterized and described. Research question #2 hypothesized that the outputs of the model could be used to determine the relationship between the number of AIS test sets and LRU waiting time. Research question #3 deals with the evaluation of the model outputs by the decision maker. While the queueing model acts as a quantitative decision aid, it must be remembered that the model is a decision support system, not a decision making system (15). Thus, the interface between the model and the decision maker becomes important and the issue of the decision maker's practical significance arises. Therefore, the third research question is: should the practical significance of the change in average LRU waiting time due to the change in the number of test sets be evaluated in addition to the statistical significance analysis of research question #2?

Summary

Three research questions were constructed to study the intermediate maintenance process of the F-16 aircraft. The first research question hypothesizes that arrival and service random variables can be described. The second research question is a theory that the relationship between AIS test sets and LRU awaiting maintenance time can be

ascertained. The third research question is a theory on the use of the decision support system by the decision maker. A correlation of the problem statement and the research questions is summarized in Table 1.

TABLE 1
CORRELATION OF PROBLEM STATEMENTS AND
RESEARCH QUESTIONS

Problem Statement	Research Question
1. Queueing theory critical items are arrival, service	1. Can arrival and service probability density functions be estimated?
2. Average time in the queue is a reasonable driver to determine appropriate number of test sets Effect of increase in number of test sets on waiting time is unknown	2. Is average wait in the queue independent of number of test sets?
3. Practical evaluation must be added to quantitative techniques in decision process	3. Are practical significance and statistical significance related?

CHAPTER II

RESEARCH METHODOLOGY

Introduction

The Queueing System

Although the LRU is the building block of the modeling process, an analytical approach will not be used to simulate the repair cycle process of the F-16. Such an approach would be too limited and would fail to include important elements and relationships involved in the complete repair cycle (9; 33; 39:36-40).

In fact, it will be necessary to model more than just the testing and repair of the LRU in order to capture all the elements and relationships necessary to depict the "real world" repair cycle of the F-16, as depicted in Figures 3 and 5. Therefore, a systems approach to modeling the F-16 LRU repair cycle must be undertaken.

The particular systems approach to be taken will be that of the system science paradigm, which consists of the three steps of conceptualization, analysis and measurement, and computerization (36:295-305). In order to use the system science paradigm, it is necessary to identify a modeling approach that can be used to most closely approximate the F-16 LRU repair cycle (36:295-305).

Several studies have shown that the repair cycle of an asset can be visualized as a queue, with arrival times generated by the failure rate of the asset, and the service times generated by the test and/or repair of the asset (1:598-623; 8:245-261; 32:VII-X,18).

Therefore, by visualizing the repair cycle of the F-16 as a system of arrivals, queues, and services, the probability calculus and statistical analysis techniques can be used to analyze the system.

Q-GERT System

Fortunately, a queueing system computer package has been developed which allows queueing activities to be modeled. Although the framework and symbology of the system is available in the computer package called Q-GERT (Queueing-Graphical Evaluation and Review Techniques), the sequence of events, parameters, and relationships in the system must be defined by the modelers based upon their experience, knowledge, and data collection (32).

Therefore, conceptualization of the problem will include a clear statement of the purpose of the system being modeled, a clear statement of the problem and what benefits might accrue to the organization if it were solved, a well-labeled structural model of the system, and a very concise description of the particular components and relationships displayed by the model (9). (The

conceptual model will be discussed in more detail as the system science paradigm is implemented in Chapter III.)

In order to use Q-GERT to complete the second step of the system science paradigm, analysis and measurement, a visual and written parametric model of the system will be constructed. To make these parameters consistent with the data one would probably encounter in the actual system, values for the parameters must be obtained from real world data collection systems. In addition, it will be necessary to outline the experimental design that will be used to ensure proper analysis of simulation results and experimentation (9).

The third phase of the system science paradigm, computerization, will be accomplished using the Q-GERT package and the developed operational computerized model. During the computerization of the model, it will be necessary to code the computer simulation model which will be developed from the structural and parametric models. It will also be necessary to test and experiment with the model by varying the independent variable(s) (the number of AIS test sets) to determine their impact on the dependent variable(s) (average LRU waiting time in the AIS queue) (1:615-617; 26:457-459; 39:219-231). Finally, a summary of simulation output and final results of the experiment will be required.

Scope/Limitations: The F-16 Ultra-High
Frequency Receiver/Transmitter
and Waiting Time

Due to the amount of data, one particular LRU of the F-16 will be used to generate the parameters of the repair cycle. Although the structural and computerized models will be general enough to simulate any or all F-16 LRUs, only the ultra-high frequency (UHF) receiver/transmitter (R/T) will be used to conduct the simulation experiment. The UHF R/T was chosen because it represented the most failures and maintenance actions among the F-16 avionics subsystems (31).

The experiment will attempt to determine how many automated test sets will significantly reduce LRU waiting time in the AIS. Any policy decisions made as a result of this experiment must be tempered by resource constraints and within the "bounded rationality" of the decision maker's knowledge and experience.

For example, the decision maker may decide that a reduction of average waiting time, ΔT , is of practical significance. The model can then address the question "if one test set is added, has this ΔT been realized?"

Finally, the relationship between the number of automated test sets and sortie generation will not be

examined, even though one might expect sortie generation to increase if fewer LRUs were awaiting service in the AIS. Limitations on the experiment, then, rest with the limits on real-world data. The simulation results will only be as accurate as the real-world maintenance data used to generate the parameters.

Cones of resolution can be employed to visually display the methodology of the simulation (36:290-292). Beer introduced the term "cones of resolution" to denote a hierarchical arrangement of models (36:290). The term has been formally defined as:

. . . hierarchically arranged levels of conceptualization with the most abstract at the top and the most concrete at the bottom. Each distinguishable feature at one level may represent a wealth of detail when examined on a larger scale at a lower level [36:336].

One cone of resolution represents the development of the paradigm used in the simulation, while the other represents the process of narrowing the scope of the experiment to the UHF R/T LRU of the F-16 system. These cones of resolution are depicted in Figures 6 and 7.

Data Collection Plan

Data collection will be used to determine the probability distributions associated with failure rates and repair times of the UHF R/T. In addition, parameters

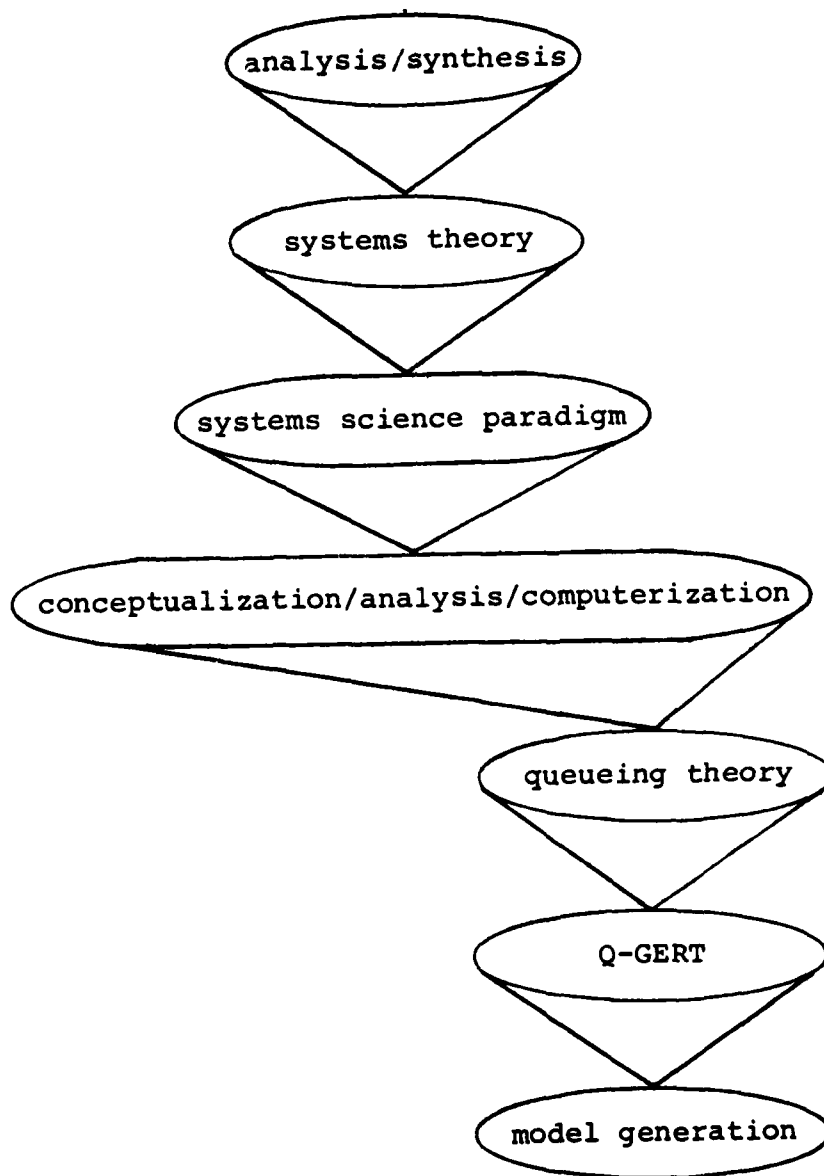

Fig. 6. Methodology Cones of Resolution
(adapted from 36:290)

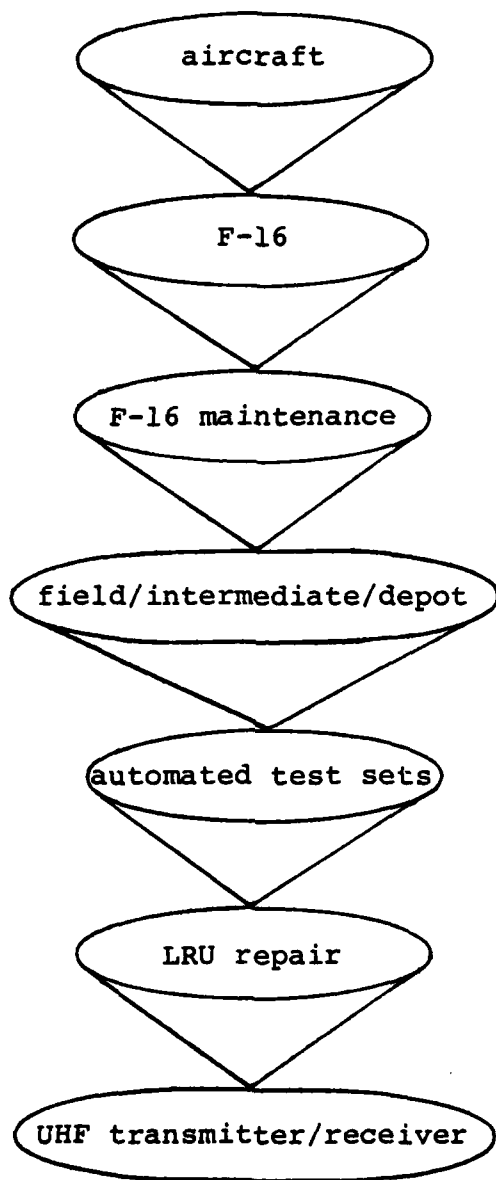

Fig. 7. Equipment Cones of Resolution
(adapted from 36:290)

for those distributions, such as the mean and variance, will be estimated from the data. Data will be collected from the Air Force Maintenance Data Collection (MDC) system, the F-16 real time data collection system (CDS), and from offices in the F-16 SPO.

Appendix B is representative of the LRU test/repair data and Appendix C illustrates failure rate data collected from the F-16 SPO's CDS.

Since the backbone of much of the estimation of distribution and parameters is from CDS, the CDS data source could be considered as the most important link between the real world and the simulation experiment. Therefore, it is important to discuss the CDS system in more detail.

CDS Data Collection System

The F-16 SPO realized that the need for information to adequately manage a major weapon system's operation is critical. Decisions involving the procurement of support equipment, such as the AIS, may involve millions of dollars of DOD investment and may cause major problems far into the future if decisions are hasty, or made without the best and most current information.

With the goal of improving the information and communications for the management of the F-16 program,

the procurement of the computerized logistics decision support package, CDS, became necessary.

The ATE-CDS Program focuses the interest in support activities on the crucial automatic test equipment sets which, on prior aircraft development programs by the Air Force, have been a source of both technical and management concern [13:pp. 1-2 to 1-3].

The DRC suggested that the CDS decision support system had two relevant issues: technical and managerial. The maintenance event data, the technical issue, provides comprehensive information collected in a timely manner on all the LRUs, component items, and the AIS itself. The data provides for

. . . detailed engineering, configuration and logistics data on these critical support equipments as well as further data on the aircraft systems maintained by the support equipment [13:p.1-4].

The managerial issue is the effective management control of the AIS, including logistics support, reliability, maintainability, and test capabilities. The CDS goal is to allow the program manager to maintain very close control and develop management continuity for the very complex AIS (13:p.1-5).

Data collection and data output are the two major functions of the ATE-CDS. The ATE-CDS will provide test station, LRU, or aircraft reliability, maintainability, and support operational requirements data. It will also provide management information on AIS usage, test station

status, LRU status, mean time between demand, parts tracking, asset status, and AIS configuration (13:pp.3-22 to 3-33).

Thus, the CDS information system allows for real-time accessibility to F-16 operations and maintenance data and will be the prime source for data collection for this research.

LRU Data Collection

Through the use of the CDS computer system at the F-16 SPO, maintenance data will be collected on the five LRUs that are currently tested on the RF station of the AIS. One LRU, the UHF R/T, work unit code 63BA0, was selected as the subject for statistical testing.

Maintenance times for AIS testing of the UHF R/T and the corresponding times to repair the unit at the intermediate level, will be taken from CDS. The data will be taken for maintenance action taken codes C and F, testing with repair deferred and testing with repair, respectively.

Data Analysis Plan: Application of Statistical Analysis

Statistical techniques will be used to analyze the data. In order to run the Q-GERT simulation model, it will be necessary to determine probability distributions and parameters for those distributions. The distributions and

parameters will then be input into the Q-GERT model and the simulation will be executed (3; 9; 32).

Data analysis will begin with the time-to-test and time-to-repair data points for the UHF R/T. Initially, a histogram will be run on the time-to-test and time-to-repair distributions to determine if the distributions graphically resemble any of the common distributions (i.e., normal, lognormal, gamma, exponential, etc.). Then, goodness-of-fit tests will be applied to test the hypothesis that the random variables (time-to-test and time-to-repair) follow the theoretically specified distributions which were derived from the histograms (10:32-36; 19:222-223; 28:200). Condescriptive statistics will also be obtained so that the means and standard deviations of time-to-test and time-to-repair can be estimated. Determination of probability distributions and parameters of time-to-test and time-to-repair will be used to represent service times in the Q-GERT model.

Next, parameters and distributions for arrival rates must be ascertained. The failure rate of the UHF R/T will be used to generate arrival rates specifications for the Q-GERT model. The arrival rate of LRUs to the AIS will be obtained from the F-16 SPO CDS-provided mean time between maintenance action data. The mean of the means will be calculated and the Central Limit Theorem will be applied in order to estimate the distribution and

parameters for arrival rate. Since the Central Limit Theorem is used, the probability distribution will be the normal distribution. However, the mean and standard error of the distribution must be estimated by obtaining condescriptive statistics (3; 33; 34).

Analysis of Results Plan: Validation
and Statistical Testing

After the data has been analyzed, the probability distributions and parameters estimated, the Q-GERT simulation model is ready to run. Upon completion of the Q-GERT simulation, it will be necessary to analyze the results. Therefore, the analysis of results plan calls for internal validation of the Q-GERT generated results and statistical testing of the Q-GERT generated output (9; 39:219-231).

The validation process will consist of: (1) tracing transactions through the Q-GERT network in order to validate that transactions (LRUs) are following appropriate paths through the system, and (2) validation of the distributions generated by the Q-GERT program to ensure that the simulation generated distributions are consistent with real-world data estimated distributions. Histograms and goodness-of-fit tests will be applied to the Q-GERT generated distributions (10:32-36; 19:312-313; 20:25,31).

After the model has been validated, it will be run three different times. Each time, the independent or control variable, the number of AIS test sets, will be

increased from one to two to three. The length of each run and number of runs will be increased until the variance of the response surface within each run, and between the runs, stabilizes (9).

In short, the control variable, number of AIS, will be varied from one to three and its effect on the response or dependent variable, average waiting time in AIS queue, will be recorded (9; 26:294,457-459; 39:150-152).

Finally, an analysis of variance (ANOVA) program will be used to test the difference in means of the response surface. If the ANOVA results indicate that the variances or the treatments are not equal, then a non-parametric Kruskal-Wallis analysis of variance test will be conducted (19:305-306,220-239; 26:456-489; 28:398-432).

Theory Testing Methodology

Research Question #1: Characterization of Arrival and Service Random Variables

The methodology which will be used to answer research question #1, determining probability distributions and parameters for failure rates, time to test and time to repair, consists of: (1) searching Air Force maintenance data collection systems to determine if such information is collected, and (2) applying histograms, descriptive statistics, goodness-of-fit tests to the data (if available) so that the distributions can be estimated.

Research Question #2: Relationship
Between AIS Test Sets and LRU
Waiting Time

Research question #2 is a statistical analysis of the response surface generated from the output of the Q-GERT model. Research question #2 asks if a change in the average waiting time occurs when the number of AIS test sets change. Parametric and/or nonparametric statistical tests (such as ANOVA and Kruskal-Wallis tests) will be applied to the response surface to determine if the change in AIS test sets statistically changed average LRU waiting times.

Research Question #3: The Practical
Significance Issue

Research question #3 attempts to determine the practical significance of the change in waiting time as the number of test sets change. While rigid statistical tests cannot be used to ascertain practical significance, an analysis of the actual waiting times distributions and parameters, based on the knowledge and experience of DOD logistics managers and a critical review of qualitative decision-making literature, could provide qualitative answers to the question of practical significance. Therefore, the methodology used to answer research question #3 will consist of a review of the actual numbers generated for average waiting time for different quantities of

test sets and a literature search to determine the limitations on purely quantitative decision support systems.

Summary

All of the tests and procedures to be used that would validate and test the results of the model are outlined in Table 2. Figure 8 shows the detailed methodology used when the system science paradigm is implemented.

TABLE 2
CORRELATION OF RESEARCH QUESTION AND METHODOLOGIES

Research Question	Methodology
1. Characterization of arrival and service random variables	1. Maintenance data collection, histograms, con-descriptive statistics, goodness-of-fit tests
2. Relationship between AIS test sets and LRU waiting time	2. Parametric and nonpara-metric statistical test-ing, ANOVA, Kruskal-Wallis Test
3. The practical signifi-cance issue	3. Condescriptive statistics, Central Limit Theorem, critical literature review, knowledge, experi-ence

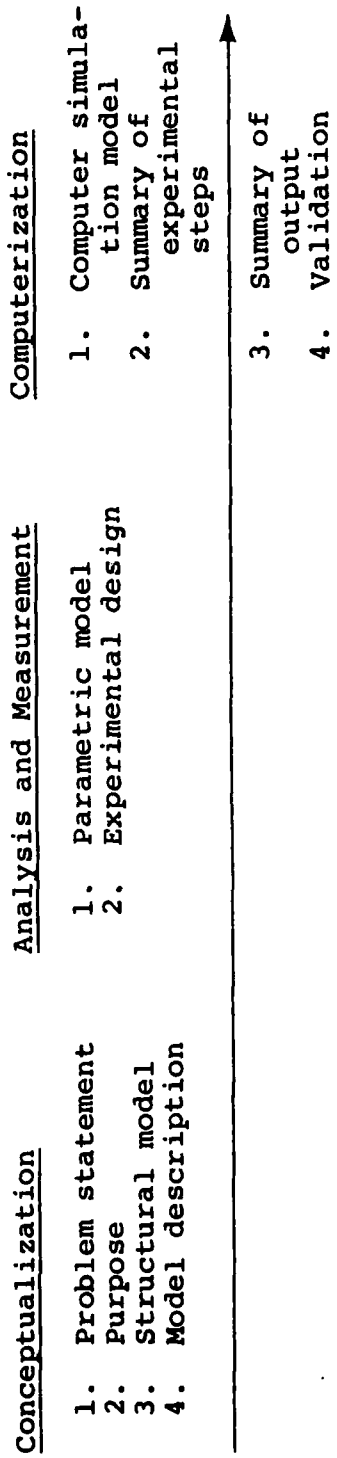

Fig. 8. Detailed Methodology Flowchart

CHAPTER III

FINDINGS

Introduction: The System Science Paradigm Implemented

Findings will be reported within the framework of the system science paradigm and will, therefore, follow the outline of conceptualization, analysis and measurement, and computerization (36:295-303). Under the conceptualization step of the system science paradigm, the following findings will be reported: (1) the purpose of the system being modeled; and (2) a structural model of the system, with a description of the components and relationships displayed by the model.

In the next step of the system science paradigm, analysis and measurement, the findings will consist of: (1) a visual and written parametric model, and (2) the experimental design used to ensure proper analyses of simulation results and experimentation.

Third, the computerization step of the system science paradigm will provide the following findings: (1) a listing of the computer simulation model which was developed from the structural and parametric models, (2) a summary of the steps that were completed as model

experimentation occurred, and (3) a summary of simulation output and the final results of the experiment.

After the findings have been reported in the framework of the system science paradigm, they will be summarized according to their relationship to the research questions. The findings, then, will consist of the simulation output, the results of using the system science paradigm as a problem-solving methodology, and their relevance to the research questions.

Step I. Conceptualization

Purpose: Modeling the Real World

The purpose of the model is to simulate the arrival, waiting, testing, repairing, and return of the UHF receiver/transmitter as it is removed from the aircraft, inspected and/or repaired at the AIS, and returned to service, or sent to the depot for repair and return (i.e., not repairable this station--NRTS).

As discussed in Chapter I, waiting time for an available AIS test set is a significant factor in determining the number of AIS test sets to acquire. By modeling the repair cycle of the LRU, a "satisficing" quantity of AIS test sets which statistically significantly reduces intermediate repair waiting time could be determined.

Structural Model: A
Causal-Loop Diagram

A causal-loop diagram of intermediate repair of F-16 LRUs might be depicted as shown in Figure 9.

The structural model indicates that as the failure rate of LRUs increases, the number of LRUs requiring maintenance increases. As the number of LRUs requiring maintenance increases, the time a LRU spends waiting for test or repair increases. As the number of LRUs requiring maintenance increases, the number of AIS test sets should increase. As the number of AIS test sets increases, the time to test a LRU decreases. Also, as the number of AIS test sets increase, the time to repair a LRU decreases. Conversely, as test time or repair time increases, the number of AIS test sets required should increase.

However, if the time to test a LRU increases, the time a LRU would spend waiting for testing or repair would increase. Likewise, if the time to repair a LRU increased, the time waiting for test or repair would increase. As time waiting for test or repair increases, the number of AIS test sets should increase.

As the number of aircraft flown increases, the number of LRUs requiring maintenance should increase. As the number of aircraft increases, the number of flying hours should increase. As the number of flying hours increases,

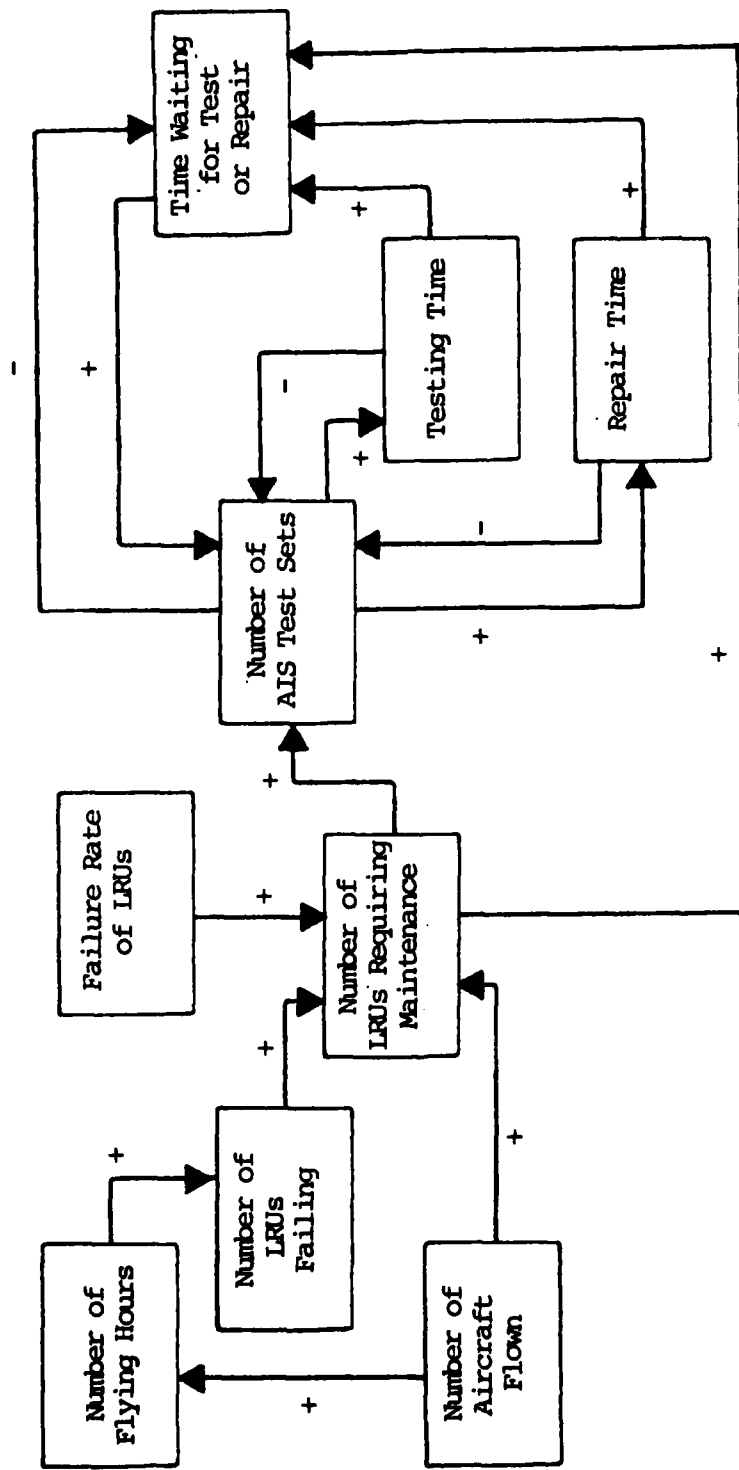

Fig. 9. Structural Model of Intermediate-Level LRU Maintenance

the number of failed LRUs should rise. As the number of failed LRUs increases, the number of LRUs requiring maintenance will increase.

If the control and stochastic variables of the model can be identified, as in the causal-loop diagram, their influence on the response variables can be determined. Therefore, a logistics manager would be able to model the changes in the response variables as a result of the changes in the control variables. Thus, if a F-16 logistics manager wants to reduce the waiting time for a LRU (response variable) by varying the number of AIS test sets (control variable), the effect of these decisions can be evaluated by modeling.

Step II. Analysis and Measurement

Parametric Model: The Structural Model Quantified

Parameters were estimated from data obtained from the F-16 SPO and by observing the LRU repair cycle process shown in Figure 5 (31). Interarrival of LRUs to the AIS was obtained from failure rate data, Appendix C (31). The mean of the means was calculated and the Central Limit Theorem applied, which resulted in the mean-time-between-maintenance actions following a normal distribution, with a mean of 150.6 hours and a standard deviation of 81.9 hours (see Appendix D) (3; 26:197-198; 34).

A small Q-GERT program, Figure 10, was designed and run using the normally distributed statistics to generate interarrival times. The small Q-GERT program was necessary because interarrival time data was not available from the SPO. Further, the mean-time-between-maintenance-action raw data (Appendix C) could not be used in the full Q-GERT model of the system because Q-GERT is limited to 50 servers per network (9) and two of the three wings/bases to be modeled required 96 servers each. (Nellis, Hill and MacDill Air Force Bases required 96, 96, and 48 servers, respectively.) The small Q-GERT program generated arrival times, shown in Table 3, to approximate the average time between arrivals of a LRU to the AIS (32:21-31).

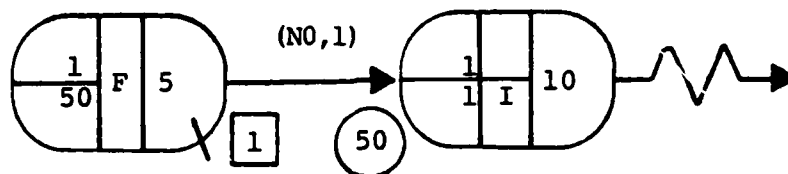

Fig. 10. Q-GERT Model to Generate Interarrival Times

Table 3 reveals that interarrival times were computed by simply subtracting the computer generated arrival time from the next highest generated arrival time. These 50 interarrival times were then used to obtain descriptive statistics. These same data points were then grouped into ten groups and formed a histogram for a visual representation of the probability density function. The results

TABLE 3

INTERARRIVAL TIME DATA
(Mean = 6.635)

Time of Arrival at AIS	Inter- Arrival Time	Time of Arrival at AIS	Inter- Arrival Time
10.52	-	157.71	6.52
18.63	8.11	174.47	16.76
41.26	22.63	176.83	2.36
51.07	9.81	178.37	1.54
51.45	.38	178.49	.12
58.21	6.76	179.25	.76
68.79	10.58	183.76	4.51
69.23	.44	184.99	1.23
90.51	21.28	187.77	2.78
97.80	7.29	191.31	3.54
100.99	3.19	191.98	.67
102.43	1.44	197.76	5.78
108.87	6.44	213.88	16.12
110.06	1.19	217.46	3.58
113.35	3.29	228.80	11.34
118.71	5.36	233.98	5.18
118.91	.20	234.60	.62
119.81	.90	240.87	6.27
120.07	.26	243.16	2.29
120.27	.20	248.81	5.65
121.58	1.31	258.41	9.60
126.57	4.99	263.11	4.70
127.58	1.01	263.40	.29
147.42	29.84	272.68	9.28
148.75	1.33	342.26	69.58
151.19	2.44		

of this exercise are shown in Appendix E1 and indicate that the interarrival times are exponentially distributed with a mean of 6.6 hours and a maximum value of 70.0 hours.

After the interarrival time random variable had been estimated, the probability of a LRU requiring testing only, or both testing and repair, was calculated. In order to determine the probability that a LRU only required testing at the AIS, the data from the F-16 SPO (Appendix B) was analyzed by the work unit code of the documented LRU maintenance actions. The probability that a LRU would only require testing time (i.e., tested and no failure found; cannot duplicate (CND), or tested and sent to depot for repair) was determined to be 0.10. Therefore, the probability that a LRU would need both test and repair at the AIS was estimated at 0.90.

The F-16 SPO data (Appendix B) was also used to estimate the parameters of time-to-test and time-to-repair. Condescriptive statistics, a histogram, and goodness-of-fit tests of the data in Table 4 resulted in the time-to-test variable estimated to be lognormally distributed with a mean of 3.5 hours and a standard deviation of 2.2 hours as shown in Appendix E2.

The time-to-repair random variable was estimated to follow a lognormal distribution with a mean of 8.1 hours and a standard deviation of 6.9 hours, as shown in Appendix E3. The estimated distributions were selected from the

TABLE 4
TEST AND REPAIR TIMES

	WUC (LRU)	Time-to-Test (Minutes)	Time-to-Repair (Minutes)
1.	63BA0	30	45
2.	"	210	1030
3.	"	180	240
4.	"	215	800
5.	"	170	120
6.	"	90	90
7.	"	420	520
8.	"	180	1150
9.	"	480	120
10.	"	195	1655
11.	"	180	295
12.	"	210	330
13.	"	510	790
14.	"	150	210
15.	"	180	1110
16.	"	455	420
17.	"	90	150
18.	"	160	95
19.	"	20	470
20.	"	30	260
21.	"	270	330
22.	"	210	720
23.	"	120	175
24.	"	135	255
25.	"	150	360
26.	"	90	360
27.	"	240	1200
28.	"	240	330
29.	"	415	60
30.	"	270	900

physical characteristics of each of the histograms, which led to testing the data against specified theoretical statistical distributions. To achieve this test, the maintenance data was hypothesized to have a lognormal distribution. The Lilliefors test for normality was used, because the population mean and standard deviation for the data sets were unknown (30). The maintenance data was converted to the logarithms of each value and was tested against the normal distribution. (If the variable is lognormally distributed, its logarithms will be normally distributed (3; 33; 34).)

Testing results for the histograms showed that the repair time might be approximated by a lognormal distribution. The testing time histogram, Appendix E2, does not depict a classic lognormal distribution; however, two of the ten intervals had no cases shown, which leads to a compacting in the right-hand tail of the distribution. The hypothesized distribution for the time-to-test was also lognormal, based on the condescriptive statistic of positive skewness, 1.178, and the shape of the histogram (10:29-32; 26:45-46; 34). In addition, the condescriptive statistics of skewness for both data sets are positive values, indicating rightward skewness and suggesting a lognormal distribution (10:29-32; 26:45-46; 34).

Of the 10 percent of the LRUs that required only testing, one-fifth, or approximately 2 percent, were sent

to the depot. The maintenance time for the depot test and repair was estimated to be lognormally distributed with a mean of 14.0 hours and a standard deviation of 11.9 hours (27). After the critical queueing system characteristics of arrivals (failure rate) and service time (test and repair time) had been estimated, definition of the entire queueing system was undertaken.

System Definition: The F-16
LRU Repair Cycle

There are two AIS test sets at Nellis and MacDill Air Force Bases (27). Hill AFB has three AIS test sets (27). The depot (at Hill AFB, Utah) has six test sets available for use (27). The time between removal of the LRU from the aircraft until arrival of the LRU at the base AIS is estimated to be a constant of one hour. Likewise, the time to return a LRU from the AIS to base supply or the flight line is estimated at a constant of one hour. The time to transport a LRU from Nellis AFB, Nevada, or MacDill AFB, Florida, to the depot is estimated to be a constant of twenty-four hours (a LOGAIR flight departs these bases for Hill AFB on a daily basis (12:20-37)). The time to transport a LRU from the Hill AFB AIS to the depot is estimated to be a constant of one hour. Similar times were estimated to return LRUs from the depot to the respective bases. It was assumed that the LRUs would be returned to the base having the largest remaining capacity

(that is, the base with the lowest fill rate of service-able LRUs). In summary, the system model parameters shown in Table 5 were estimated and verified.

Other parametric models developed were:

1. Time in AIS for test = Test Time
2. Time in AIS for repair = Test Time +
Repair Time
3. Waiting time in AIS = Test Time + Repair
Time - Time of Arrival

The Q-GERT Model

All of the parameters, assumptions, logic, and real-world limitations have now been developed. A Q-GERT model can now be developed which integrates all of these factors and simulates the real world. Figure 11 is a visual depiction of the model using standard Q-GERT symbols. (For a complete description of Q-GERT symbology, see Appendix A.)

The model simulates the repair cycle at three Air Force bases (Nellis, Hill, and MacDill) and the depot repair facility, also located at Hill AFB. Although selector node 2 is shown first, the system actually begins with Q nodes 5, 40, and 70. These nodes hold operational and spare LRUs. They represent 96 operationally ready aircraft and four spare LRUs for Nellis and Hill AFBs respectively, and 48 operationally ready aircraft and two

TABLE 5
MODEL PARAMETERS

Variable	Distribution/ Constant	Mean	Std Dev	Verified by
Interarrival Time	Exponential	6.635	N/A	SPSS/Q-GERT
Prob of Test	.10	N/A	N/A	F-16 Data
Prob of Test and Maint	.90	N/A	N/A	F-16 Data
Time-to-Test	Lognormal	3.49	2.17	SPSS
Time-to-Repair	Lognormal	8.11	6.9	SPSS
Prob of NRTS	.02	N/A	N/A	F-16 Data
Depot Repair Time	Lognormal	14.0	11.91	Depot
Nellis Test Sets	2	N/A	N/A	Data
MacDill Test Sets	2	N/A	N/A	Data
Hill Test Sets	3	N/A	N/A	Data
Depot Test Sets	6	N/A	N/A	Data

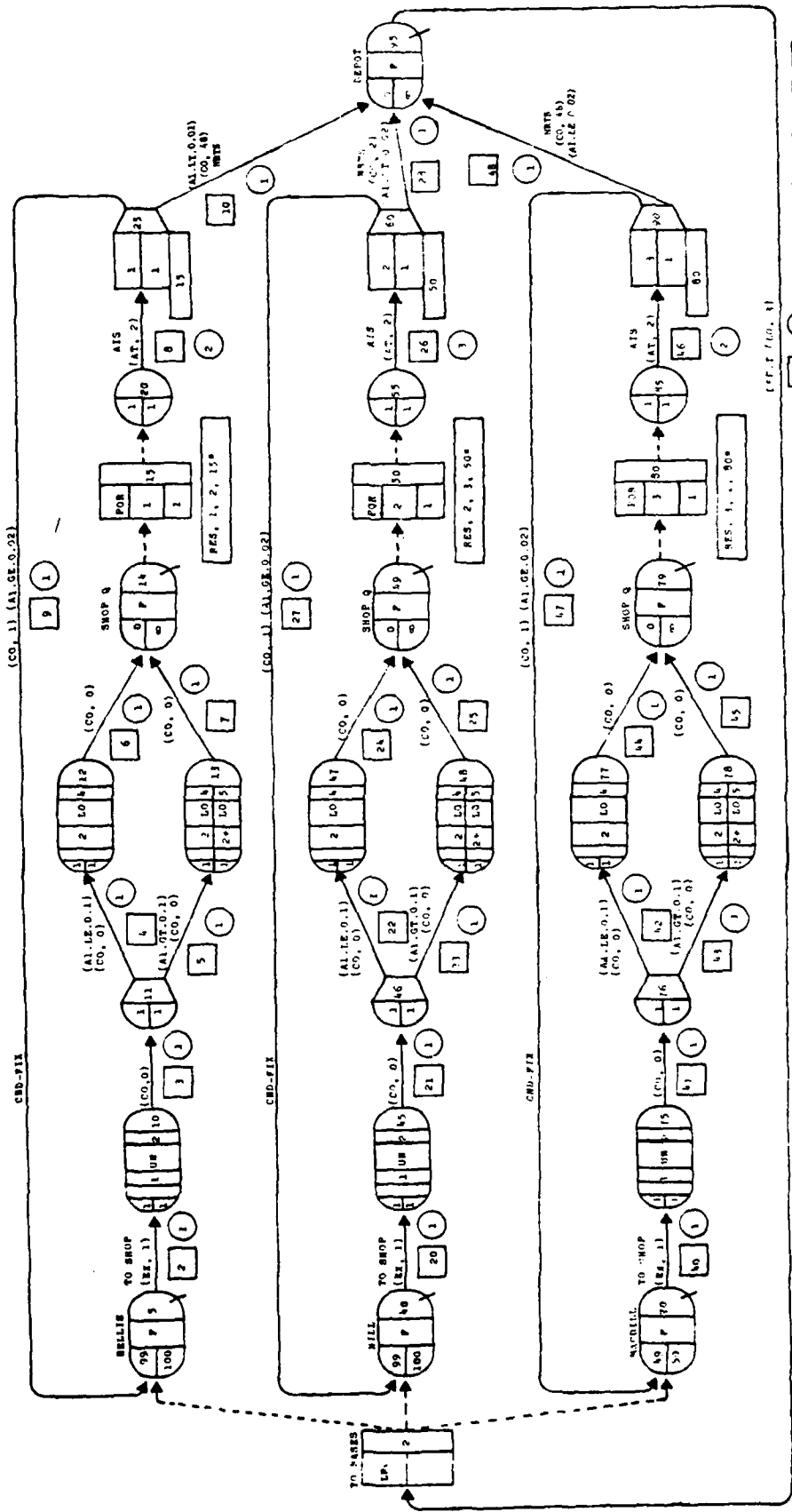

1	1	1	1	1	1
2	1	1	1	1	1
3	1	1	1	1	1
4	1	1	1	1	1
5	1	1	1	1	1
6	1	1	1	1	1
7	1	1	1	1	1
8	1	1	1	1	1
9	1	1	1	1	1
10	1	1	1	1	1
11	1	1	1	1	1
12	1	1	1	1	1
13	1	1	1	1	1
14	1	1	1	1	1
15	1	1	1	1	1
16	1	1	1	1	1
17	1	1	1	1	1
18	1	1	1	1	1
19	1	1	1	1	1
20	1	1	1	1	1
21	1	1	1	1	1
22	1	1	1	1	1
23	1	1	1	1	1
24	1	1	1	1	1
25	1	1	1	1	1
26	1	1	1	1	1
27	1	1	1	1	1
28	1	1	1	1	1
29	1	1	1	1	1
30	1	1	1	1	1
31	1	1	1	1	1
32	1	1	1	1	1
33	1	1	1	1	1
34	1	1	1	1	1
35	1	1	1	1	1
36	1	1	1	1	1
37	1	1	1	1	1
38	1	1	1	1	1
39	1	1	1	1	1
40	1	1	1	1	1
41	1	1	1	1	1
42	1	1	1	1	1
43	1	1	1	1	1
44	1	1	1	1	1
45	1	1	1	1	1
46	1	1	1	1	1
47	1	1	1	1	1
48	1	1	1	1	1
49	1	1	1	1	1
50	1	1	1	1	1
51	1	1	1	1	1
52	1	1	1	1	1
53	1	1	1	1	1
54	1	1	1	1	1
55	1	1	1	1	1
56	1	1	1	1	1
57	1	1	1	1	1
58	1	1	1	1	1
59	1	1	1	1	1
60	1	1	1	1	1
61	1	1	1	1	1
62	1	1	1	1	1
63	1	1	1	1	1
64	1	1	1	1	1
65	1	1	1	1	1
66	1	1	1	1	1
67	1	1	1	1	1
68	1	1	1	1	1
69	1	1	1	1	1
70	1	1	1	1	1
71	1	1	1	1	1
72	1	1	1	1	1
73	1	1	1	1	1
74	1	1	1	1	1
75	1	1	1	1	1
76	1	1	1	1	1
77	1	1	1	1	1
78	1	1	1	1	1
79	1	1	1	1	1
80	1	1	1	1	1
81	1	1	1	1	1
82	1	1	1	1	1
83	1	1	1	1	1
84	1	1	1	1	1
85	1	1	1	1	1
86	1	1	1	1	1
87	1	1	1	1	1
88	1	1	1	1	1
89	1	1	1	1	1
90	1	1	1	1	1
91	1	1	1	1	1
92	1	1	1	1	1
93	1	1	1	1	1
94	1	1	1	1	1
95	1	1	1	1	1
96	1	1	1	1	1
97	1	1	1	1	1
98	1	1	1	1	1
99	1	1	1	1	1
100	1	1	1	1	1

Fig. 11. Q-GERT Simulation Model of IRU Maintenance

spare LRUs for MacDill AFB. Activities 2, 20, and 40 generate interarrival times using parameter set 1 (see legend, Figure 11) for reparable (broken) LRUs. These transactions are then assigned attributes (AT) 1 at nodes 10, 45, and 75. The attributes are taken from a uniform distribution using parameter set 2 (see legend, Figure 11). Attribute 1 assigns the probability that a transaction (LRU) will require testing only (0.10), testing and repair (0.90), and/or NRTS (0.02).

Next, the transactions move to conditional branching nodes 11, 46, and 76. Here, AT 1 is used to determine the correct path for the LRU. If AT 1 is less than, or equal to, 0.10, the LRU moves to nodes 12, 47, or 77. These nodes represent test only and attribute 2 is assigned using parameter set 4 (see legend, Figure 11). If AT 1 is greater than 0.10, the LRU moves to nodes 13, 48, or 78. These nodes represent test and repair. Attribute 2 is assigned to the LRU using both parameter set 4 (test time) and parameter set 5 (repair time).

From nodes 12, 13, 47, 48, 77, or 78 the LRU moves to the respective repair shop Q-node (nodes 14, 49, and 79). Here, the LRU either waits in the queue for an AIS test set to become available, or moves directly into the repair cycle if a test set is available. Test set availability is determined in allocate nodes 15, 50, and 80. These nodes have resources (test sets) that are limited to two

at Nellis AFB, three at Hill AFB, and two at MacDill AFB. At the beginning of the simulation all test sets are available. When a LRU is allocated a test set, the resources are decremented by one until the time assigned to AT 2 for that LRU has elapsed. That resource cannot be used again until it is freed at nodes 25, 60, and 90.

From nodes 15, 50, and 80, the LRU moves to regular nodes 20, 55, or 85. These nodes are used to move the LRU through the system. Activities 8, 26, and 46 represent the AIS test and repair activities. Here is where service time occurs based upon AT 2. Once a LRU has been tested, repaired, or NRTS'd, it flows to conditional branching nodes 25, 60, or 90. These nodes serve a dual purpose. First, they free the resource (test set) to make it available for use. Second, based on attribute 1, the determination is made whether the LRU is tested and returned to the aircraft or base supply without repair, tested and repaired and returned to the aircraft or base supply, or if it is not reparable this station (NRTS) and sent to the depot for repair. In the first two cases, if AT 1 is greater than, or equal to, 0.02, the LRU is returned to Q-node 5, 40, or 70, and the number in the supply queue is incremented by one. If AT 1 is less than 0.02, the LRU is sent to depot (Q-node 95) with time assigned at activities 10, 28, and 48. In the case of Nellis and MacDill AFBs, the time is a constant of 48 hours (24 hours to the

depot and 24 hours back to the respective base). For Hill AFB, a constant two hours is assigned (one hour to the repair facility and one hour for return). From node 95, activity 50 assigns a depot repair time using parameter set 3 (see legend, Figure 11). The LRU then moves to selector node 2 where the determination is made which base has the largest remaining capacity (difference between authorized and on-hand LRUs). Once the selection has been made, the appropriate supply Q-node (5, 40, or 70) is incremented by one.

Experimental Design: Treatments and Observations

The experiment was designed to measure the response variable (average waiting time) as changes in the control variable (number of test sets) occurred. The stochastic variables would change based on sampling random numbers from appropriate distributions as characterized by the parametric distributions of the stochastic variables. The variables in Table 6 are applicable to the experimental design.

For this experiment, the number of test sets available was varied from one to three in order to determine its effect on the average waiting time in the AIS. Each treatment (number of test sets) was simulated for a 30-day period. Twelve 30-day periods were plotted with their corresponding average waiting times.

TABLE 6

MODEL VARIABLES

Control	Stochastic	Response
Number of Test Sets	Test Time	Waiting Time in AIS
Number of LRUS	Repair Time	AIS Utilization
	Interarrival Time	
	Probability of Test	
	Probability of Test & Repair	
	Depot Maintenance Time	

An analysis of variance test will be conducted to determine if the mean waiting time in the AIS is statistically significantly different when there are one, two, or three test sets available to support intermediate test and/or repair of the F-16 LRU. If the means are essentially the same, one test set should be the basis of decision making when attempting to determine support equipment requirements for I-level repair of the F-16. If the means are different, statistical tests will be applied to determine how far apart the means are. If the analysis of variance indicates that there is a difference in mean waiting time between one and two test sets, but not between two and three test sets, two sets should be the basis for beginning the discussion of how many test sets to acquire to support I-level repair of F-16 LRUs. However, any decision should include both the statistically generated solution and its impact on the practical significance issues as identified by the decision maker within the context of the resources available in the environment.

Step III. Computerization

Computer Listing

A listing of the computer simulation model used to simulate the intermediate repair of F-16 LRUs is provided in Appendix F.

Model Experimentation

Upon completion of the parametric model and the coding and running of the appropriate Q-GERT model, validation of the parameters generated by the Q-GERT simulation was attempted. The validation process consisted of:

- (1) tracing transactions through the network in order to validate that transactions (LRUs) were following appropriate paths through the system (see Appendix G); and
- (2) validation of the distributions generated by the Q-GERT program. Histograms and goodness-of-fit tests were applied to the Q-GERT generated distributions (19:220-239,312-313; 20:25,31; 22). The tests and printouts, as shown in Appendix H, indicate that the Q-GERT model generated distributions were representative of the parametric model distributions based on real-world data. Specifically, Appendix H1 verifies that the depot maintenance times generated by the Q-GERT simulation are lognormally distributed. Appendix H2 shows that the simulation generated intermediate level repair times are lognormally distributed. Confirmation of lognormally generated intermediate level test times was provided by Appendix H3. Appendix H4 confirmed that the Q-GERT simulation model was providing attribute assignments from the required uniform distribution. Appendix H5 validated the exponential distribution of LRU interarrival times.

Based on the trace of transactions and the application of goodness-of-fit tests, the Q-GERT model was determined to be an internally validated representation of the system of intermediate level repair of F-16 LRUs. After the model had been validated, it was run with one AIS test set as a server, two AIS test sets as servers, and three AIS test sets as servers. Each run consists of 30 days of activity. Twelve runs of the 30-day period were used to simulate one year's activity. The 30-day and 12-month periods were chosen in order to stabilize the variance of the average waiting time in the AIS queue. In short, the control variable (number of AIS test sets) was varied from one to three and its effect on the response variables (average waiting time in the AIS queue) was recorded. Twelve observations (based on a 30-day observation period) were documented by the Q-GERT analysis program (as shown in Appendix I). A response surface of the treatment (varying the number of test sets) and results (average waiting time in the queue) are shown in Table 7.

Simulation Output

A summary of 12 observations of average waiting time in the AIS queue is provided in Appendix I. An analysis of variance program was used to test the difference in means of the response surface (see Appendix J1). Since the ANOVA indicated that the variances of the three

TABLE 7

RESPONSE SURFACE

Month	No. of AIS	Avg Wait in AIS	No. of AIS		Avg Wait in AIS	No. of AIS		Avg Wait in AIS
			Month	No. of AIS		Month	No. of AIS	
1	1	133.1650	1	2	7.8901	1	3	1.2052
2	1	106.4483	2	2	8.1673	2	3	1.4301
3	1	152.3622	3	2	34.1603	3	3	0.7196
4	1	100.5774	4	2	5.2073	4	3	0.4811
5	1	120.1054	5	2	9.1965	5	3	1.1960
6	1	134.2600	6	2	19.9342	6	3	0.7421
7	1	126.5589	7	2	4.6320	7	3	1.5382
8	1	141.5084	8	2	8.4789	8	3	0.9766
9	1	142.0566	9	2	9.0976	9	3	0.9775
10	1	151.0634	10	2	3.3998	10	3	1.3323
11	1	154.4595	11	2	31.1164	11	3	2.5879
12	1	103.2550	12	2	7.4907	12	3	1.3509

treatments were not equal, a nonparametric Kruskal-Wallis analysis of variance test was conducted (Appendix J2). The results, Appendix J1, indicated that the mean waiting time in the AIS queue is greater if only one AIS test set is available; however, the average waiting time in the AIS is not statistically significantly different if two or three AIS test sets are available. Specifically, when the simulation was executed with one AIS test set as the server, the average waiting time was normally distributed (Central Limit Theorem) with a mean of 130.5 hours and a standard error of 19.3 hours as shown in Appendix J3. When two AIS test sets were available as servers, the average waiting time was normally distributed (Central Limit Theorem) with a mean of 12.4 hours and a standard error of 10.3 hours (Appendix J3). When three AIS test sets were available for service, the average waiting time was normally distributed (Central Limit Theorem) with a mean of 1.2 hours and a standard error of 0.5 hours (Appendix J3). Table 8 summarizes the impact of the number of AIS test sets on LRU average waiting time for service. At the 99 percent confidence level, the population distributions of average waiting time for two and three test sets are statistically the same (Appendix J1). However, if the practical significance of the addition of a test set was to reduce mean average waiting time by ten (10) hours, then the difference in average waiting time would be

TABLE 8
EFFECT OF CHANGE IN AIS TEST SETS ON LRU
AVERAGE WAITING TIME

Number of AIS Test Sets	Average Waiting Time in Hours		
	Distribution	Mean	Standard Error
1	Normal	130.485	19.2839
2	Normal	12.3976	10.3245
3	Normal	1.2115	0.5384

significant because the third test set reduced mean average waiting time by 11.2 hours (12.3976 - 1.2115).

Findings and Their Relevance
to Research Questions

Research Question #1: Character-
ization of Arrival and Service
Random Variables

The interarrival time probability distribution was found to be estimatable by an exponential distribution (histogram, Appendix E1), with a mean of 6.6 hours and a maximum value of 70.0 hours (condescriptive statistics, Appendix E1). The time-to-test random variable findings resulted in an estimated lognormal distribution (histogram, goodness-of-fit test, Appendix E2), with a mean of 3.5 hours and a standard deviation of 2.2 hours (condescriptive statistics, Appendix E2). Findings for the time-to-repair random variable resulted in an estimated lognormal distribution (histogram, goodness-of-fit test, Appendix E3),

with a mean of 8.1 hours and a standard deviation of 6.9 hours (condescriptive statistics, Appendix E3).

Research Question #2: Relationship
Between AIS Test Sets and LRU
Waiting Time

The analysis of variance findings, Appendix J1, showed that the variance among the three groups of average waiting times was not the same (P values for Cochran's C and Bartlett's Box are 0.000); therefore, a nonparametric analysis of variance test must be conducted. The nonparametric Kruskal-Wallis one-way ANOVA test, Appendix J2, resulted in a significance value finding of 0.000, thus, average waiting times for the three treatments of one, two, and three AIS test sets are not the same.

Since the findings relative to research question #2 indicated that there was a difference in average waiting times when the number of test sets was changed, the Duncan's Multiple Range Test, Appendix J1, was used to determine if average waiting times were the same when one or two test sets were available. The findings reveal that the group representing one AIS test set (group 1) was placed in a unique subset (subset 2) and would therefore not be included in the same population as the group with two AIS test sets (group 2).

The Duncan's Multiple Range test (Appendix J1) shows that the average waiting time group with two AIS test sets (group 2) and the average waiting time group

with three AIS test sets (group 3) are included in the same subset population (subset 1).

Research Question #3: The Practical Significance Issue

Findings relative to research question #3 were the response surface (Table 7 and Appendix I), the one-way analysis of variance output (Appendix J3) and the review of literature on the importance of qualifying quantitative generated answers to complex problems through the use of individual knowledge and experience. The response surface and analysis of variance results indicate that the average waiting time variable when one test set is available is normally distributed with a mean of 130.5 hours and a standard error of 19.3 hours. The average waiting time random variable when two test sets are available is normally distributed with a mean of 12.4 hours and a standard error of 10.3 hours. The average waiting time random variable when three AIS test sets are available is normally distributed with a mean of 1.2 hours and a standard error of 0.5 hours. A review of the literature on the use of purely quantitative decision support systems (DSS) reminds the decision maker that "a DSS supports and does not replace the manager [21:58]." Furthermore, the literature reveals that:

This emphasis on enhancement of decision making exploits those aspects of computers and analytical techniques that are appropriate for the problem and

leaves the remainder to the manager. Most, if not all, of manager's key decisions tend to be fuzzy problems, not well understood by them or the organization, and their personal judgement is essential. It is not possible to think of a computer system replacing managers or most of their decisions. . . . The key point for a DSS is to support or enhance the manager's decision-making ability [21:58].

Therefore, there is evidence to indicate that the mean waiting time in the AIS could be statistically significantly decreased by producing two sets; however, the procurement of three test sets does not statistically significantly reduce the average waiting time in the queue of the AIS work center. On the other hand, practical significance of the reduction in average waiting time must be determined by the individual decision maker.

Summary

The findings presented in this chapter were correlated to the research questions that were developed in Chapter I. Table 9 is a summary of this correlation.

TABLE 9

CORRELATION OF RESEARCH QUESTIONS AND FINDINGS

Research Question	Findings
1. Characterization of arrival and service random variables	1. Interarrival times are exponentially distributed with mean of 6.6 hours and a maximum value of 70 hours; time-to-test random variable is lognormally distributed with mean of 3.5 hours and standard deviation of 2.2 hours; time-to-repair random variable is lognormally distributed with mean of 8.1 hours and standard deviation of 6.9 hours.
2. Relationship between AIS test sets and LRU waiting time	2. ANOVA tests show variances are not equal; Kruskal-Wallis tests show average waiting times are not equal when the number of test sets are varied. Duncan's Multiple Range test shows average waiting time with one test set would not be included in the same group as two test sets. Duncan's Multiple Range test shows average waiting time with two test sets could be included in the same group with three test sets.
3. The practical significance issue	3. Oneway ANOVA test reveals average waiting time random variable for one test set is normally distributed with mean of 130.5 and standard deviation of 19.3 hours; average waiting time for two test sets is normally distributed with mean of 12.4 hours and standard deviation of 10.3 hours; average waiting time for three test sets is normally distributed with mean of 1.2 hours and standard deviation of 0.5 hours; literature review consistently states the importance of using quantitative DSS to support, not replace, the decision-making task.

CHAPTER IV

CONCLUSIONS AND RECOMMENDATIONS

Introduction

Several conclusions can be formulated as a result of the Q-GERT simulation of the F-16 LRU repair cycle process. In addition to the conclusions drawn from the results of the simulation output, there are also conclusions which can be postulated as a result of the statistical analysis of the F-16 raw data. Several conclusions led to recommendations for F-16 logistics managers, and may be useful when planning for support equipment (SE) requirements during weapon systems acquisitions or when studying areas from Air Force maintenance data collection systems. Finally, the research raised some questions which were not within the scope of this experiment and which should be studied further by future logistics managers or students. Thus, this chapter identifies conclusions, recommendations, and additional research requirements. The conclusions and recommendations will be summarized in the framework of the research questions. Finally, the thesis will be summarized.

Conclusions

Conclusions were reached by: (1) a statistical analysis of F-16 real-world LRU failure, test, and repair data; (2) a statistical analysis of the results of the Q-GERT generated LRU awaiting maintenance times as the number of AIS sets was varied; and (3) a practical evaluation of the results generated by the Q-GERT simulation model.

Research Question #1: Characterization of Arrival and Service Random Variables

Conclusion #1 was reached through a statistical analysis of the raw data. The condscriptive statistical analysis and histogram of the F-16 UHF R/T LRU failure data resulted in the conclusion that the failure rate random variable was exponentially distributed with a mean of 6.6 hours and a maximum value of 70.0 hours. It was concluded that the average time-to-test the F-16 UHF R/T was 3.5 hours and that testing time was lognormally distributed with a standard deviation of 2.2 hours. Time-to-repair the UHF R/T was also concluded to be lognormally distributed with a mean of 8.1 hours and a standard deviation of 6.9 hours. Ultimately, it was concluded that the important arrival rate characteristic (as represented by the failure rate) and the service rate characteristic (as represented

by the test and repair rates) for the queueing model of the F-16 LRU repair cycle could, indeed, be estimated.

Research Question #2: Relationship
Between AIS Test Sets and LRU
Waiting Time

The hypothesis that the mean waiting time in the AIS queue was the same, regardless of the number of test sets, was concluded to be false. An analysis of the response surface mean waiting time in the AIS queue, generated by the Q-GERT simulation model, revealed that mean waiting time was not the same when the number of test sets was increased from one to two to three. Therefore, the theory that average LRU waiting time is independent of the number of AIS test sets was rejected and it was concluded that there was a difference in mean waiting time if one, two, or three test sets were procured to support the F-16 AIS.

Since the theory that average LRU waiting time and the number of AIS test sets are independent was rejected, two subtheories were formulated. First, it was theorized that the significant reduction occurred when the second test set was added. Second, it was theorized that the significant reduction occurred with the third test set. These theories were tested by determining if the mean waiting time in the AIS queue was reduced with two test

sets but not with three, or if the reduction occurred with the addition of the third test set but not with the addition of the second test set. As a result of the statistical analysis of the Q-GERT generated response surface, it was concluded that a statistically significant reduction in AIS queue waiting time occurred when two test sets were available; however, the reduction was not statistically significant when there were three test sets available. Therefore, the procurement of two AIS test sets will statistically significantly reduce LRU waiting time in the AIS; however, the procurement of three AIS test sets will not statistically significantly reduce AIS queue waiting time.

Research Question #3: The Practical Significance Issue

The statistical analysis of the response surface indicates there is a significant difference in mean waiting time between one and two AIS test sets but not between two and three AIS test sets. While statistically significant, a logistics manager might be interested in the actual numbers. For example, in the case where the choice was between one and two test sets, the mean waiting time for one is 130.5 hours and the mean for two is 12.4 hours. The difference of approximately 118 hours on the average is significant at the .01 level. However, the significance must also be weighed against other criteria which the decision maker may establish. If the decision maker

estimated that each average reduction in LRU waiting time would save \$10.00 per hour, then the savings as a result of increasing the number of AIS test sets from one to two would be approximately \$1,180 per month. As a result, the decision maker could use the estimated savings as a "break-even point" when deciding whether or not to add the additional test set. If the cost of the additional test set was less than or equal to \$1,180 per month, the test set should probably be added. If the costs were greater than \$1,180 per month, the decision should be made based on a determination of the significance of the 118 hour reduction in LRU waiting time. The increase in sortie generation or aircraft available, for example, might warrant the addition of the second test set even though it costs more than \$1,180 per month. In the case where the choice was between two and three test sets, the mean for two is 12.4 hours with a standard error of 10.3 and the mean for three is 1.2 hours with a standard error of 0.5. The difference of approximately 11 hours, on the average, is statistically insignificant at the .01 level; therefore, procurement of a third AIS test set would not significantly reduce LRU waiting time. This data must be weighed in terms of spares availability, mission criticality and other operational and logistics commitments. Thus, it was concluded that the results of the simulation experiment must be evaluated in accordance with the decision maker's

knowledge, experience, and practical significance levels. In this case, had the decision maker established a significant reduction of waiting time as meeting practical significance requirements, then the decision might be to procure the second test set, but not the third.

Recommendations

Research Question #1: Characterization of Arrival and Service Random Variables

As a result of the statistical analysis of the F-16 LRU real-world raw data, it is recommended that F-16 logistics managers use statistical techniques to analyze real-world maintenance data. Determination of probability distributions and estimated parameters to characterize those distributions would increase the F-16 logistics managers's knowledge of key variables in the F-16 repair cycle process and would be necessary to define arrival and service system characteristics in the Q-GERT model.

Research Question #2: Relationship Between AIS Test Sets and LRU Waiting Time

As a result of the Q-GERT simulation output, it is specifically recommended that two AIS test sets be identified to support the F-16 if average waiting time in the AIS queue is to be statistically significantly reduced. Currently, one avionics intermediate shop has three AIS test sets while others have two. Since the additional (third) AIS

test set does not statistically significantly reduce waiting time in the AIS queue, it is recommended that two test sets be considered as the standard procured for all F-16 Avionics Intermediate Shops. These recommendations are further qualified in the recommendation for research question #3.

Research Question #3: The Practical Significance Issue

Based on a qualitative review of the average waiting times, as the number of test stations was varied, and a critical review of the DSS literature, it is recommended that practical significance thresholds be established in addition to formal statistical significance requirements when evaluating DSS outputs. The ultimate decision must be made by the DOD logistics managers based upon the quantitative results from the DSS and on practical significance criteria generated by the decision makers. The decision maker's knowledge and experience are the key to generating the practical significance criteria. The key point is that the DSS must be used to support, and not to make, the final decision.

Review of Conclusions and Recommendations

A summary of the research questions and the resulting conclusions and recommendations is shown in Tables 10 and 11.

TABLE 10
CORRELATION OF RESEARCH QUESTIONS AND CONCLUSIONS

Research Question	Conclusions
<p>1. The time-to-test random variable distribution can be estimated.</p> <p>The time-to-repair random variable distribution can be estimated.</p> <p>The mean and standard deviation of the time-to-test random variable can be estimated.</p> <p>The mean and standard deviation of the time-to-repair random variable can be estimated.</p> <p>The failure rate random variable distribution can be estimated.</p> <p>The failure rate mean and maximum value can be estimated.</p>	<p>1. Fail to reject that time-to-test follows a lognormal distribution.</p> <p>Fail to reject that time-to-repair follows a lognormal distribution</p> <p>Estimated time-to-test mean is 3.5 hours. Estimated standard deviation is 2.2 hours.</p> <p>Estimated time-to-repair mean is 8.1 hours. Estimated standard deviation is 6.9 hours.</p> <p>Fail to reject that the failure rate follows an exponential distribution.</p> <p>Estimated failure rate mean is 6.6 hours. Estimated maximum value is 70.0 hours.</p>
<p>2. Average waiting time in AIS queue is not affected by the number of AIS test sets.</p>	<p>2. Reject this theory. Average waiting time in AIS queue is significantly reduced if test sets are increased from one to two but not if increased from two to three.</p>

TABLE 10--Continued

Research Question	Conclusions
3. Should practical significance levels be used to evaluate model results?	3. Results of simulation must be evaluated using decision maker's knowledge, experience, and practical significance levels.

TABLE 11
CORRELATION OF RESEARCH QUESTIONS AND RECOMMENDATIONS

Research Question	Recommendation
1. Characterization of arrival and service random variables	1. Use statistical techniques to analyze real-world data.
2. Relationship between AIS test sets and LRU waiting time	2. If the sole criteria is to statistically reduce average LRU waiting time, then two AIS R/F test sets should be procured to support intermediate repair of F-16 UHF R/T.
3. The practical significance issue	3. Practical and statistical significance criteria should be established and used to evaluate decision support system output.

Additional Research Requirements

First, although the thesis developed a Q-GERT simulation model which could be used to model the entire F-16 LRU repair cycle process, only the UHF R/T LRU data was used in the experiment. Therefore, further research should be conducted using the other F-16 LRUs to determine if the findings and conclusions herein are representative of the entire F-16 LRU repair cycle.

Second, in addition to average waiting time in the AIS queue, the impact on other response variables, such as aircraft availability, sortie generation, etc., should be determined by using the Q-GERT model and by varying the number of AIS test sets. Therefore, further research with other response variables is recommended.

Third, although the thesis has demonstrated the applicability of the Q-GERT model in the acquisition of support equipment, the model could also be used in the determination of the number of spares required to support the F-16. Instead of varying the number of AIS test sets, the number of spares could be varied and its impact on selected response variables could be measured. Therefore, it is recommended that research be conducted into the use of the Q-GERT model as an aid in identifying spares to support the F-16.

Fourth, another area of initial logistics support which could be evaluated using the Q-GERT model is

training. Estimates of reductions in time-to-test and time-to-repair due to changes in training could be made and implemented into the Q-GERT model. These changes could then be used to determine their impact on selected dependent variables in the F-16 program. It is recommended that further research into the use of Q-GERT as a decision aid in planning and conducting training be undertaken.

Finally, cost-benefit analysis should be conducted to determine if the reduction in waiting time obtained by procuring additional AIS test sets is worth the cost of the additional sets.

Summary

The statistical techniques applied to 30 data points for a F-16 RF LRU validated the assumption that theoretical distributions can be used to describe the time-to-test, time-to-repair, and failure rate random variables. In addition, the mean and standard deviations of the random variables can be estimated. The data obtained in the statistical analysis was applied to a Q-GERT simulation model of F-16 intermediate level repair. Although these statistical techniques were only applied against data on one F-16 LRU, it is reasonable to assume that these techniques could be applied throughout logistics support analysis of the entire F-16 program.

The Q-GERT simulation experiment demonstrated the use of systems theory, queueing techniques, and Q-GERT simulation as a decision support tool for Air Force logistics managers. The methodology of the system science paradigm and its use in development of a simulation model was illustrated and validated by statistical techniques. Three research questions were developed and answered by using simulation to model the real-world repair cycle process of F-16 LRUs. The hypothesis that the number of AIS automated test sets does not affect average LRU waiting time in the intermediate maintenance shop was rejected. It was further concluded that F-16 acquisition logistics managers should consider the procurement of two AIS test sets to support the F-16, but procurement of three AIS test sets would not statistically significantly reduce LRU waiting time in the AIS. These statistical conclusions, however, were qualified by reminding the reader that practical significance requirements must also be considered when evaluating the results of a decision support system. Recommendations for the use of systems theory, queueing techniques, and simulation to evaluate acquisition logistics decisions were outlined and opportunities for further research were presented. Thus, it was demonstrated that theoretical paradigms and statistical tools can be used as effective decision support systems in the real-world decision-making process of determining life cycle logistics

support requirements. With the current emphasis on increased defense spending and the use of computers in the Department of Defense, it is imperative that Air Force decision makers evaluate alternatives as comprehensively as possible. The use of the methodology presented in this thesis should be considered as a way of improving the multi-million dollar decision-making tasks of Air Force logistics managers.

AD-A123 051

A DECISION SUPPORT SYSTEM FOR ACQUISITION OF F-16
AVIONICS INTERMEDIATE S... (U) AIR FORCE INST OF TECH
WRIGHT-PATTERSON AFB OH SCHOOL OF SYST...

2/2

UNCLASSIFIED

G C BRYSON ET AL. SEP 82 AFIT-LSSR-11-82

F/G 1/3

NL

END
DATE
FILMED
6-84
DTIC

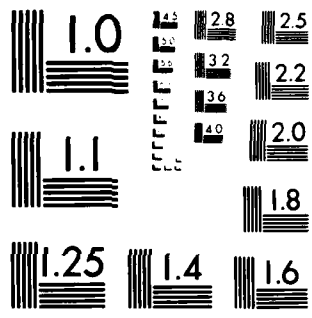

MICROCOPY RESOLUTION TEST CHART
NATIONAL BUREAU OF STANDARDS-1963 A

APPENDICES

APPENDIX A
ABBREVIATIONS, ACRONYMS, AND SYMBOLOGY

This appendix gives the commonly used abbreviations or acronyms involved with the acquisition and logistics support of the F-16 weapon system, and the terminology of queueing theory. Also included in this appendix is the symbology--giving the commonly used statistical symbols and the Q-GERT symbology used in the Q-GERT simulation model.

Abbreviations and Acronyms

AFB	- Air Force Base
AFIT	- Air Force Institute of Technology
AIS	- Avionics Intermediate Shop
ANOVA	- Analysis of Variance
ATE	- Automatic Test Equipment
ATE-AIS	- Automatic Test Equipment-Avionics Intermediate Shop
CDS	- Centralized Data System
CI	- Control/Indicators Test Station of AIS
CND	- Cannot Duplicate
CONUS	- Continental United States
DI	- Display/Indicators Station of AIS
DOD	- Department of Defense
DRC	- Dynamics Research Corporation
DSS	- Decision Support System
I-LEVEL	- Intermediate Level of Maintenance

Abbreviations--Continued

- LOGAIR - Logistics Air
- LRU - Line Replaceable Unit
- MDC - Maintenance Data Collection System
- Mean Arrival Rate - The expected number of units arriving or entering the system in a given period of time
- Mean Service Rate - The expected number of units that can be serviced by one server in a given period of time
- Operating Characteristics - The performance characteristics of a waiting line such as average units in system, average size of the queue, and average waiting time in queue
- PP - Pneumatic Processor Test Station of AIS
- Q-GERT - Queueing-Graphical Evaluation and Review Techniques Program
- Queue - A Waiting Line
- RF - Radio Frequency test Station of AIS
- RFP - Request for Proposal
- R/T - Receiver/Transmitter LRU of F-16
- SE - Support Equipment
- SPO - Systems Program Office
- UHF - Ultra-High Frequency

Symbols

- H_a - Alternate Hypothesis
- H_0 - Null Hypothesis
- μ - Mean
- $=$ - Equals
- \neq - Does Not Equal
- Δ - Delta, denoting change

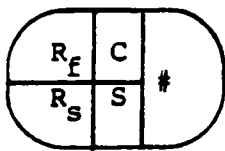

- R_f is the number of incoming transactions required to release the node for the first time.

R_s is the number of incoming transactions required to release the node for all subsequent times.

C is the criterion for holding the attribute set at a node.

S is the statistics collection type or marking.

is the node number.

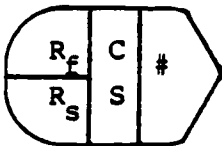

 indicates deterministic branching from the node.

 indicates probabilistic branching from the node.

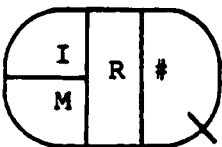



- I is the initial number of transactions at the Q-node.

M is the maximum number of transactions permitted at the Q-node.

R is the ranking procedure for ordering transactions at the Q-node.

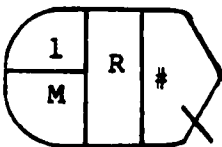
is the Q-node number.



-  Pointer to a source node or from a sink node.

Symbols--Continued

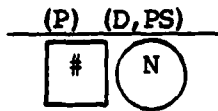

- P is the probability of taking the activity (only used if probabilistic branching from the start node of the activity is specified).

D is the distribution or function type from which the activity time is to be determined.

PS is the parameter set number (or constant value) where the parameters for the activity time are specified.

is the activity number.

N is the activity of parallel servers associated with the activity (only used if the start node of the activity is a Q-node).

Concept: Value Assignment

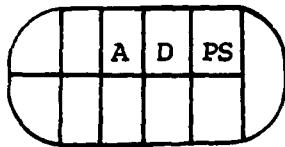

- A is the attribute number to which a value is to be assigned; if A+ is specified, add value to attribute A; if A- is specified, subtract value from attribute A.

D is the distribution or function type from which assignment value is to be determined.

PS is the parameter set number.

Concept: Queue Ranking

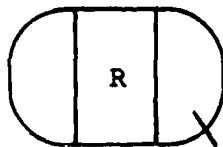

- R is the ranking procedure for ordering transactions at the Q-node. R can be specified as F + FIFO; L + LIFO; B/i + Big value of attribute i. S/i + Small value of attribute i. If i=M, ranking is based on mark time.

Concept: Conditional, Take-First Branching

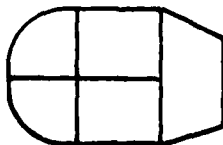

-  indicates conditional-take first branching from the node.

Symbols--Continued

(C) (D,PS) →

Concept: Condition Specification for Branch

- C is the condition specification for taking the activity.

(P) (D,PS)

Concept: Attribute Based Probabilistic Branching

- If $P < 1.0$, P is the probability of taking the activity.
If $P \geq 1$, P is an attribute number.

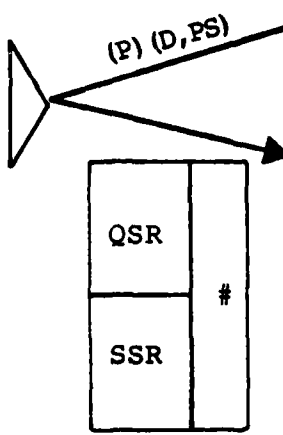

Concept: Selector node or S-node

- QSR is the queue selection rule for routine transactions to or from Q-nodes.
SSR is the server selection rule for deciding which server to make busy if a choice exists.
is the S-node number.

Concept: Routing Indicator

- Routing indicator for transaction flow to or from Q-nodes to S-nodes or Match nodes.

APPENDIX B

F-16 SYSTEMS PROGRAM OFFICE MAINTENANCE DATA

Appendix B, F-16 Systems Program Office Maintenance

Data, contains direct CDS output for 63BA0, RF station receiver/transmitter including: the Job Control number, column one; the maintenance action start time, column two; the maintenance action close-out time, column three; the date the maintenance action was recorded, column four; and the action taken code, column five.

<u>JCN</u>	<u>START TIME</u>	<u>END TIME</u>	<u>DATE</u>	<u>ACTION TAKEN</u>
2949717	9.00	9.30	801020	C
2949427	12.00	15.30	801022	C
3153807	8.00	11.00	801112	C
3209413	12.00	15.35	801117	C
3389491	15.40	18.30	801204	C
3524003	19.30	21.00	801217	C
0054000	13.30	15.30	810105	C
0054000	15.30	19.00	810105	C
0054000	18.00	19.30	810105	C
0216463	13.00	16.00	810122	C
0336503	14.00	22.00	810202	C
0339751	16.15	19.30	810202	C
0335048	17.30	20.30	810202	C
0362830	16.00	19.30	810205	C
0369608	13.30	21.30	810206	C
0369608	9.00	9.30	810212	C
0459601	13.30	16.00	810217	C
0499421	20.30	23.30	810219	C
0649768	10.15	17.50	810309	C
0914050	19.00	20.30	810401	C
0919517	13.00	15.40	810407	C

<u>JCN</u>	<u>STATE TIME</u>	<u>END TIME</u>	<u>DATE</u>	<u>ACTION TAKEN</u>
0979771	22.30	22.50	810407	C
0989614	23.00	23.30	810408	C
0993813	16.00	20.30	810410	C
1046156	16.30	21.00	810415	C
1066576	20.30	22.30	810416	C
1059517	5.45	8.00	810417	C
1036663	12.30	15.00	810417	C
1106117	16.45	18.15	810421	C
1129786	20.00	24.00	810428	C
1279750	3.00	7.00	810508	C
1264014	.05	7.00	810512	C
1056650	11.00	15.30	810515	C
2949427	15.30	22.30	801022	F
2949427	8.00	16.00	801023	F
2949427	18.00	19.10	801023	F
2949717	7.00	7.45	801028	F
3153807	12.00	16.00	801112	F
3209413	15.40	20.00	801117	F
3209413	12.00	16.00	801118	F
3209413	16.00	21.00	801118	F
3389491	9.30	11.30	801206	F
3524003	22.30	24.00	801217	F
0054000	20.15	23.00	810105	F
0054000	9.05	15.00	810106	F
0054400	13.50	16.00	810108	F
0054400	16.00	23.45	810108	F
0054400	7.40	12.15	810109	F
0216463	16.15	23.00	810122	F
0216463	.05	7.00	810123	F
0216463	5.00	7.00	810127	F
0216463	7.00	11.30	810127	F
0336503	22.30	23.30	810202	F

<u>JCN</u>	<u>START TIME</u>	<u>END TIME</u>	<u>DATE</u>	<u>ACTION TAKEN</u>
0335048	23.00	24.00	810202	F
0335048	.05	4.00	810203	F
0362830	23.00	24.00	810205	F
0339751	9.00	12.00	810206	F
0362830	24.00	5.30	810206	F
0339751	16.00	23.00	810211	F
0369608	13.00	14.30	810212	F
0369608	16.00	17.30	810212	F
0369608	16.00	18.00	810217	F
0459601	16.00	16.30	810217	F
0459601	18.00	21.00	810217	F
0369608	22.15	6.15	810717	F
0369608	7.50	15.00	810218	F
0369608	16.00	17.00	810218	F
0499421	7.30	15.30	810220	F
0499421	15.30	18.00	810220	F
0499421	15.00	16.30	810221	F
0499421	12.00	18.30	810222	F
0339751	21.00	21.45	810303	F
0649768	11.00	16.00	810312	F
0649768	19.00	19.30	810312	F
0649768	1.00	1.30	810313	F
0649768	7.00	8.00	810313	F
0339751	8.00	9.00	810324	F
0339751	10.30	16.00	810325	F
0339751	16.00	19.15	810325	F
0914050	22.30	24.00	810401	F
0914050	7.00	8.00	810402	F
0919517	15.40	16.15	810407	F
0979771	16.00	21.00	810408	F
0989614	4.30	7.10	810409	F
0989614	7.10	8.50	810409	F
0993813	16.00	16.30	810415	F

<u>JCN</u>	<u>START TIME</u>	<u>END TIME</u>	<u>DATE</u>	<u>ACTION TAKEN</u>
0993813	17.30	22.30	810415	F
1066576	.05	3.00	810417	F
1046156	7.00	12.00	810417	F
1059517	15.30	16.15	810417	F
0979771	16.30	17.00	810417	F
1046156	8.00	15.00	810420	F
1036663	15.00	15.30	810420	F
1036663	15.30	19.00	810420	F
0979771	16.15	18.35	810422	F
1059517	23.45	24.00	810428	F
1059517	13.15	16.30	810429	F
1129786	16.00	23.00	810429	F
1129786	17.00	22.00	810430	F
1106117	16.00	22.00	810505	F
1264014	7.00	8.00	810512	F
1279750	12.30	18.00	810512	F
1056650	15.30	23.00	810515	F
1056650	14.00	15.30	810518	F
1056650	15.30	23.00	810518	F
1056650	9.00	14.30	810527	F
1056650	18.00	23.30	810527	F

APPENDIX C
FAILURE RATE DATA

The failure rate data of Appendix C shows the F-16 mean time between maintenance actions for work unit code 63BA0, the UHF receiver/transmitter. The data, generated by the CDS at the F-16 SPO, shows the dates (the months from June 1979 through September 1981) with the monthly calculated mean time between maintenance actions and the cumulative figures for mean time between maintenance actions.

F-16 MTBMA FOR WUC: 63BA0 NOUN: RECIV-TRANS UHF

<u>DATE</u>	<u>MONTHLY MTBMA</u>	<u>CUMULATIVE MTBMA</u>
7906	94.83	46.33
7907	386.80	61.81
7908	60.05	61.43
7909	223.00	77.07
7910	292.00	96.03
7911	106.89	98.30
7912	176.16	106.41
8001	268.18	118.86
8002	131.89	120.96
8003	138.40	123.59
8004	95.90	117.87
8005	43.66	93.13
8006	60.14	86.61
8007	123.45	90.28
8008	130.25	93.89
8009	140.94	97.22

<u>DATE</u>	<u>MONTHLY MTBMA</u>	<u>CUMULTATIVE MTBMA</u>
8010	66.96	91.83
8011	182.84	96.83
8012	120.27	98.55
8101	95.45	98.27
8102	96.34	98.09
8103	153.52	101.88
8104	100.88	101.79
8105	110.88	102.52
8106	171.92	106.38
8107	302.64	113.27
8108	220.53	114.45
8109	122.63	114.97

APPENDIX D
CONDESCRIPTIVE STATISTICS OF FAILURE DATA

Appendix D, Condescriptive Statistics of Failure Data, shows the final computer output of the condescrptive statistics for the F-16 SPO failure data from Appendix C.

MEAN	150.621	STD ERROR	15.487	STD DEV	81.949
VARIANCE	6715.614	KURTOSIS	1.410	SKEWNESS	1.276
RANGE	343.140	MINIMUM	43.660	MAXIMUM	386.800
SUM	4217.400				

APPENDIX E
CONDESCRIPTIVE STATISTICS, HISTOGRAMS, AND
GOODNESS-OF-FIT TESTS

Appendix E is divided into three parts. Appendix E-1 is computer-generated condescriptive statistics and histogram of the interarrival time data of Table 3. Appendix E2 is computer-generated condescriptive statistics, histogram, and goodness-of-fit test of the test times as shown in Table 4. Appendix E3 is computer-generated condescriptive statistics, histogram, and goodness-of-fit test of the repair times as shown in Table 4.

APPENDIX E1
INTERARRIVAL TIME CONDESCRIPTIVE STATISTICS
AND HISTOGRAM

VARIABLE	IAT				
MEAN	6.635	STD DEV	10.706	STD ERROR	1.514
VARIANCE	114.620	SKEWNESS	4.451	KURTOSIS	24.696
RANGE	69.460	MAXIMUM	69.580	MINIMUM	0.120
SUM	331.740				

VALID OBSERVATIONS - 50

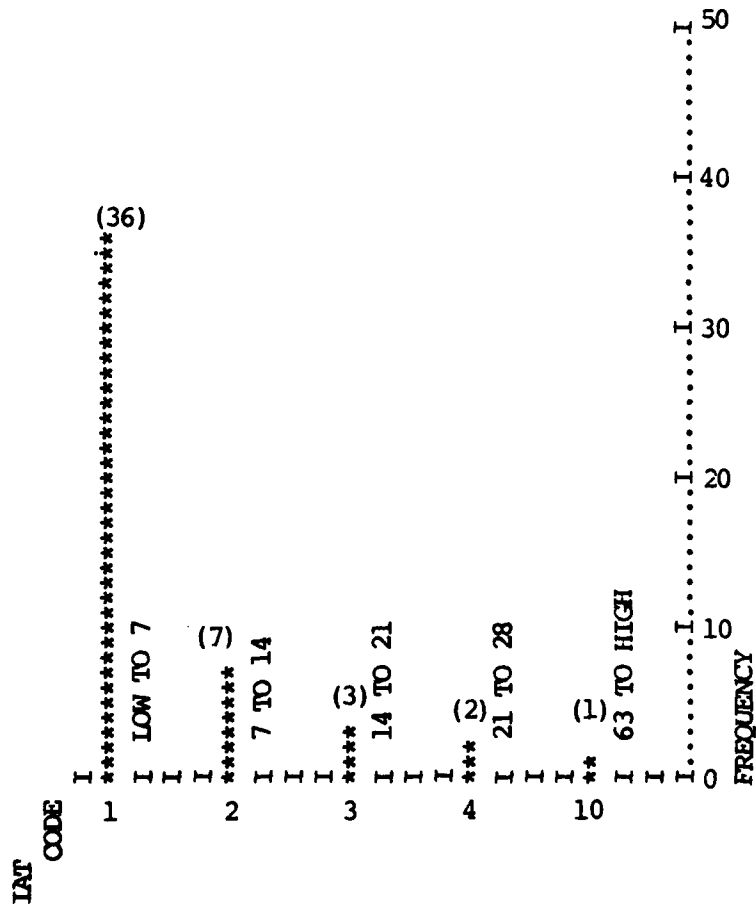

APPENDIX E2

CONDESCRIPTIVE STATISTICS, HISTOGRAM, AND
GOODNESS-OF-FIT TESTS FOR TIME-TO-TEST
RANDOM VARIABLE

VARIABLE TEST

MEAN	3.49 hrs.	STD ERROR	23.757	STD DEV	2.17 hrs
VARIANCE	16931.868	KURTOSIS	0.355	SKENNESS	0.912
RANGE	490.000	MINIMUM	20.000	MAXIMUM	510.000
SUM	6295.000				

VALID OBSERVATIONS - 30

MISSING OBSERVATIONS - 0

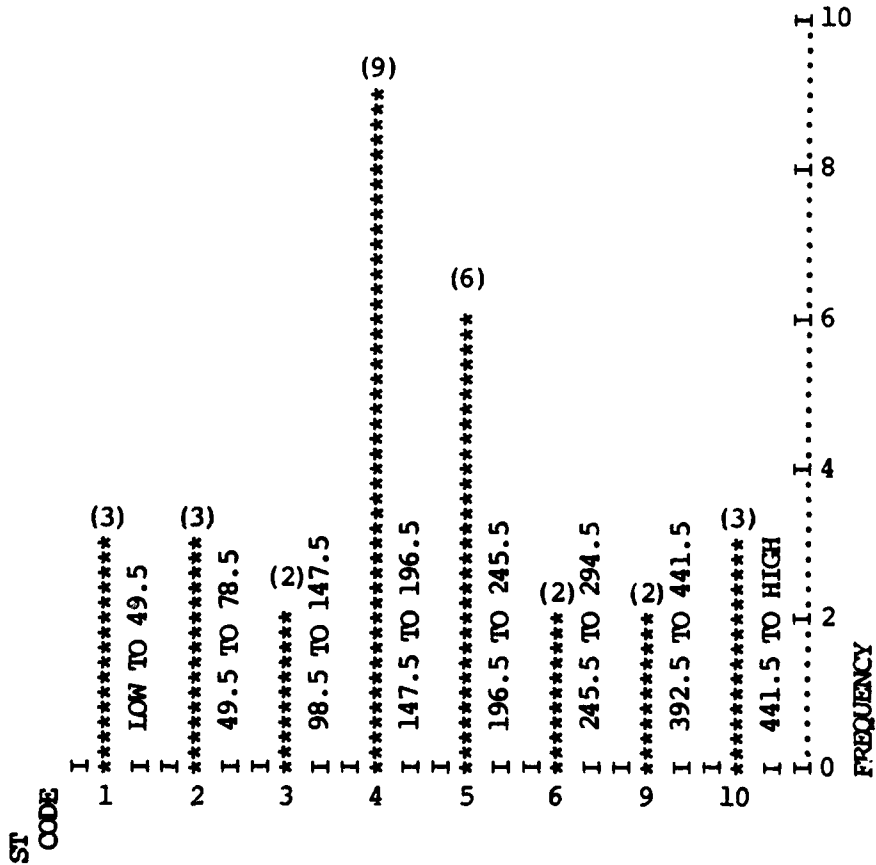

KOLMOGOROV-SMIRNOV GOODNESS OF FIT TEST

TEST DIST. - NORMAL (MEAN = 5.1145 STD. DEV. = 0.7826)

CASES	MAX(ABS DIFF)	MAX(+ DIFF)	MAX(-DIFF)
30	0.1806	0.1015	-0.1806
K-S Z	2-TAILED P		
0.989	0.282		

Time to Test, Lilliefors Test

H_0 : Logarithms of time-to-test random variables follow a normal distribution; time-to-test variables are lognormally distributed.

H_a : Logarithms of time-to-test values are not normally distributed; time-to-test is not lognormally distributed.

Since 0.1806 (MAX ABS DIFF) < .187 (n=30, $\alpha=.01$ from Lilliefors Table) .

the null hypothesis that the time-to-test is lognormally distributed

cannot be rejected.

APPENDIX E3

CONDESCRIPTIVE STATISTICS, HISTOGRAM, AND
GOODNESS-OF-FIT TESTS FOR TIME-TO-REPAIR
RANDOM VARIABLE

VARIABLE REPAIR

MEAN	8.11 hrs.	STD ERROR	75.590	STD DEV	6.9 hrs.
VARIANCE	171415.402	KURTOSIS	0.710	SKEWNESS	1.178
RANGE	1610.000	MAXIMUM	45.000	MAXIMUM	1655.000
SUM	14590.000				

VALID OBSERVATIONS - 30

MISSING OBSERVATIONS - 0

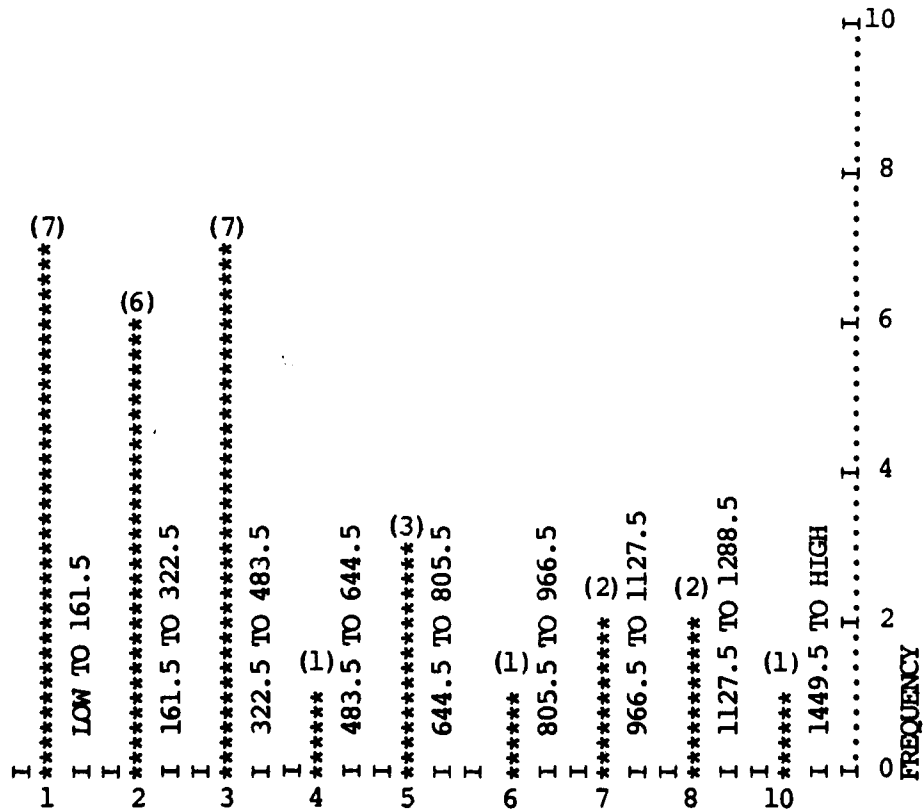

KOLMOGOROV-SMIRNOV GOODNESS OF FIT TEST

TEST DIST. - NORMAL (MEAN = 5.8058 STD. DEV. = 0.9429)

CASES	MAX (ABS DIFF)	MAX (+DIFF)	MAX (-DIFF)
30	0.0940	0.0661	-0.0940
K-S Z	2-TAILED P		
0.515	0.954		

Time to Repair, Lilliefors Test

H_0 : Logarithms of time-to-repair random variables follow a normal distribution; time-to-repair variables are lognormally distributed.

H_a : Logarithms of time-to-repair random variables do not follow a normal distribution; time to repair variables are not lognormally distributed.

Since .0940 (MAX ABS DIFF) < .187 (n=30, $\alpha=.01$ from Lilliefors Table) the null hypothesis that the time-to-repair is lognormally distributed cannot be rejected.

APPENDIX F
Q-GERT SIMULATION MODEL PROGRAM

Appendix F, Q-GERT Simulation Model Program, contains the computer input to run the Q-GERT simulation program.

*** INPUT CARDS ***

GEN,BRYSON,AIS,(10)720,12,C,0,2*
QUE,5/NELLIS,99,100,D,F*
QUE,40/HILL,99,100,D,F*
QUE,70/MACDILL,49,50,D,F*
ACT,5,10,EX,1,2/N-TOSHOP,1*
ACT,40,45,EX,1,20/H-TOSHOP,1*
ACT,70,75,EX,1,40/M-TOSHOP,1*
SEL,2/TO-BASES,LRC,(7)5,40,70*
REG,10,1,1,D*
VAS,10,1,UN,2*
ACT,10,11,CO,0.,3,1*
REG,45,1,1,D*
VAS,45,1,UN,2*
ACT,45,46,CO,0.,21,1*
REG,75,1,1,D*
VAS,75,1,UN,2*
ACT,75,76,CO,0.,41,1*
REG,11,1,1,F*
REG,46,1,1,F*
REG,76,1,1,F*
ACT,11,12,CO,0.,4,1,(9)Al.LE.0.1*
ACT,11,13,CO,0.,5,1,(9)Al.GT.0.1*
ACT,46,47,CO,0.,22,1,(9)Al.LE.0.1*
ACT,46,48,CO,0.,23,1,(9)Al.GT.0.1*
ACT,76,77,CO,0.,42,1,(9)Al.LE.0.1*
ACT,76,78,CO,0.,43,1,(9)Al.GT.0.1*
REG,12,1,1,D*
VAS,12,2,LO,4*
REG,13,1,1,D*
VAS,13,2,LO,4,2+,LO,5*
REG,47,1,1,D*
VAS,47,2,LO,4*
REG,48,1,1,D*
VAS,48,2,LO,4,2+,LO,5*
REG,77,1,1,D*
VAS,77,2,LO,4*
REG,78,1,1,D*
VAS,78,2,LO,4,2+,LO,5*

ACT,12,14,CO,0.,6,1*
ACT,13,14,CO,0.,7,1*
ACT,47,49,CO,0.,24,1*
ACT,48,49,CO,0.,25,1*
ACT,77,79,CO,0.,44.1*
ACT,78,79,CO,0.,45,1*
QUE,14,0.,,D,F,(10)15*
QUE,49,0.,,D,F,(10)50*
QUE,79,0.,,D,F,(10)80*
RES,1,2,15*
RES,2,3,50*
RES,3,2,80*
ALL,15,POR,1,1,14/20*
ALL,50,POR,2,1,49/55*
ALL,80,POR,3,1,79/85*
QUE,20,0.,,D,F*
QUE,55,0.,,D,F*
QUE,85,0.,,D,F*
ACT,20,25,AT,2,8/AIS-N,2*
ACT,55,60,AT,2,26/AIS-H,3*
ACT,85,90,AT,2,46/AIS-M,2*
FRE,25,F,1,1,15*
FRE,60,F,2,1,50*
FRE,90,F,3,1,80*
ACT,25,5,CO,1.,9/RET-N-FL,1,(9)Al.GE.0.02*
ACT,25,95,CO,48.,10/N-NRTS,1,(9)Al.LT.0.02*
ACT,60,40,CO,1.,27/RET-H-FL,1,(9)Al.GE.0.02*
ACT,60,95,CO,2,28/H-NRTS,1,(9)Al.LT.0.02*
ACT,90,70,CO,1.,47/RET-M-FL,1,(9)Al.GE.0.02*
ACT,90,95,CO,48.,48/M-NRTS,1,(9)Al.LT.0.02*
QUE,95/DEPOT,0.,,D,F*
ACT,95,2,LO,3,50/DEPOT,6*
PAR,1,6.635,0.,70.*
PAR,2,,0,1.*
PAR,3,14.,0.,49.73,11.91*
PAR,4,3.5,0.,10.01,2.17*
PAR,5,8.11,0.,28.81,6.9*
FIN*

APPENDIX G
Q-GERT TRACE

Appendix G, Q-GERT trace, gives a sampling of the Q-GERT output to enable the user to follow, or trace, individual transactions through the Q-GERT system. Four individual trace sections have been extracted to provide a test that the simulation model functioned as it was designed to. Part I shows a transaction that was repaired and subsequently returned to the same base that completed the service activity, one trace from each of the three bases. Part II shows a transaction that underwent the test activity and was subsequently returned to the same base that completed the service activity, one for each of the three bases. Part III shows transactions that were considered not reparable this station (NRTS), forwarded to the depot service activity and subsequently returned to a base activity, one trace from each of the three bases.

REPAIR AND RETURN TO BASE QUEUE (DIRECT)

Start Node	End Node	Start Time	End Time	Acty #	Trans Number	Attributes	
						1	2
<u>Nellis</u>							
5	10	0.00	0.06	2	1	0.00	0.00
10	11	0.06	0.06	3	1	0.21	0.00
11	13	0.06	0.06	5	1	0.21	0.00
13	14	0.06	0.06	7	1	0.21	8.70
***	14	-	0.06	7	1	0.21	8.70
***	20	-	0.06	0	1	0.21	8.70
20	25	0.06	8.76	8	1	0.21	8.70
25	5	8.76	9.76	9	1	0.21	8.70
<u>Hill</u>							
40	45	0.00	0.01	20	101	0.00	0.00
45	46	0.01	0.01	21	101	0.91	0.00
46	48	0.01	0.01	23	101	0.91	0.00
48	49	0.01	0.01	25	101	0.91	11.30
***	49	-	0.01	25	101	0.91	11.30
***	55	-	0.01	0	101	0.91	11.30
55	60	0.01	11.31	26	101	0.91	11.30
60	40	11.31	12.31	27	101	0.91	11.30
<u>MacDill</u>							
70	75	0.00	17.88	40	201	0.00	0.00
75	76	17.88	17.88	41	201	0.98	0.00
76	78	17.88	17.88	43	201	0.98	0.00
78	79	17.88	17.88	45	201	0.98	7.68
***	79	-	17.88	45	201	0.98	7.68
***	85	-	17.88	0	201	0.98	7.68
85	90	17.88	25.56	46	201	0.98	7.68
90	70	25.56	26.56	47	201	0.98	7.68

TEST AND RETURN TO BASE QUEUE (DIRECT)

Start Node	End Node	Start Time	End Time	Acty #	Trans Number	Attributes	
						1	2
<u>Nellis</u>							
5	10	76.86	94.84	2	16	0.00	0.00
10	11	94.84	94.84	3	16	0.09	0.00
11	12	94.84	94.84	4	16	0.09	0.00
12	14	94.84	94.84	6	16	0.09	2.71
***	14	-	94.84	6	16	0.09	2.71
***	20	-	94.84	0	16	0.09	2.71
20	25	94.84	97.55	8	16	0.09	2.71
25	5	97.55	98.55	9	16	0.09	2.71
<u>Hill</u>							
40	45	188.63	190.93	20	132	0.00	0.00
45	46	190.93	190.93	21	132	0.09	0.00
46	47	190.93	190.93	22	132	0.09	0.00
47	49	190.93	190.93	24	132	0.09	1.19
***	49	-	190.93	24	132	0.09	1.19
***	55	-	190.93	0	132	0.09	1.19
55	60	190.93	192.12	26	132	0.09	1.19
60	40	192.12	193.12	27	132	0.09	1.19
<u>MacDill</u>							
70	75	172.18	180.22	40	237	0.00	0.00
75	76	180.22	180.22	41	237	0.09	0.00
76	77	180.22	180.22	42	237	0.09	0.00
77	79	180.22	180.22	44	237	0.09	4.00
***	79	-	180.22	44	237	0.09	4.00
***	85	-	247.59	0	237	0.09	4.00
85	90	247.59	251.59	46	237	0.09	4.00
90	70	251.59	252.59	47	237	0.09	4.00

TEST AND NRTS TO DEPOT FOR REPAIR AND RETURN TO BASE

Start Node	End Node	Start Time	End Time	Acty #	Trans Number	Attributes	
						1	2
<u>Hill</u>							
40	45	186.37	188.63	20	131	0.00	0.00
45	46	188.63	188.63	21	131	0.01	0.00
46	47	188.63	188.63	22	131	0.01	0.00
47	49	188.63	188.63	24	131	0.00	1.89
***	49	-	188.63	24	131	0.00	1.89
***	55	-	188.63	0	131	0.01	1.89
55	60	188.63	190.52	26	131	0.01	1.89
60	95	190.52	192.52	28	131	0.01	1.89
***	95	-	192.52	28	131	0.01	1.89
95	2	192.52	196.32	50	131	0.01	1.89
***	2	-	196.32	50	131	0.01	1.89
70	75	505.16	509.27	40	131	0.01	1.89
<u>MacDill</u>							
70	75	82.41	91.40	40	217	0.00	0.00
75	76	91.40	91.40	41	217	0.00	0.00
76	77	91.40	91.40	42	217	0.00	0.00
77	79	91.40	91.40	44	217	0.00	3.83
***	79	-	91.40	44	217	0.00	3.83
***	85	-	124.18	0	217	0.00	3.83
85	90	124.18	128.02	46	217	0.00	3.83
90	95	128.02	176.02	48	217	0.00	3.83
***	95	-	176.02	48	217	0.00	3.83
95	2	176.02	179.17	50	217	0.00	3.83
***	2	-	179.17	50	217	0.00	3.83
70	75	497.26	500.52	40	217	0.00	3.83
<u>Nellis</u>							
5	10	111.28	113.17	2	23	0.00	0.00
10	11	113.17	113.17	3	23	0.02	0.00
11	12	113.17	113.17	4	23	0.02	0.00
12	14	113.17	113.17	6	23	0.02	2.22
***	14	-	113.17	6	23	0.02	2.22
***	20	-	131.82	0	23	0.02	2.22
20	25	131.82	134.03	8	23	0.02	2.22
25	95	134.03	182.03	10	23	0.02	2.22
***	95	-	182.03	10	23	0.02	2.22
95	2	182.03	184.70	50	23	0.02	2.22
***	2	-	184.70	50	23	0.02	2.22
70	75	500.52	501.14	40	23	0.02	2.22

APPENDIX H
GOODNESS-OF-FIT TESTS AND A HISTOGRAM

Appendix H consists of five parts. Appendix H1 is a goodness-of-fit test to validate lognormal distribution of Q-GERT generated depot maintenance times. Appendix H2 is a goodness-of-fit test to validate lognormal distribution of Q-GERT generated AIS repair times. Appendix H3 is a goodness-of-fit test to validate lognormal distribution of Q-GERT generated AIS test times. Appendix H4 is a goodness-of-fit test to validate the uniform distribution random number generator of the Q-GERT simulation program. Appendix H5 is a histogram of the interarrival times generated by the Q-GERT simulation model to validate that they are exponentially distributed.

APPENDIX H1
LILLIEFORS TEST OF Q-GERT GENERATED
DEPOT MAINTENANCE TIMES

KOLMOGOROV-SMIRNOV GOODNESS OF FIT TEST

TEST DISTRIBUTION - NORMAL (Mean = 1.9004, STD DEV = 0.9286)

CASES = 6 MAX(ABS DIFF) = 0.2287

K-S Z = 0.560 2-TAILED P = 0.912

n=6; $\alpha=0.01$ Lilliefors Table Value = .364

H_0 : Distribution of depot maintenance times is lognormal; logarithms of depot maintenance times are normally distributed.

H_a : Distribution of depot maintenance times is not lognormal; logarithms of depot maintenance times are not normally distributed.

Since $.2287 < .364$, cannot reject null hypothesis that depot maintenance times are lognormally distributed.

APPENDIX H2

LILLIEFORS TEST OF Q-GERT GENERATED AIS
REPAIR TIMES

KOLMOGOROV-SMIRNOV GOODNESS OF FIT TEST

TEST DISTRIBUTION - NORMAL (MEAN = 2.3093, STD DEV = 0.4675)

CASES = 87 MAX(ABS DIFF) = 0.0570

K-S Z = 0.531 2-TAILED P = 0.940

n=87; $\alpha=0.01$ Lilliefors Table Value = .1105

H_0 : Distribution of AIS repair times is lognormal;
logarithms of repair times are normally distributed.

H_a : Distribution of AIS repair times is not lognormal;
logarithms of repair times are not normally distributed.

Since $.0570 < .1105$, cannot reject null hypothesis that
AIS repair times are lognormally distributed.

APPENDIX H3

LILLIEFORS TEST OF Q-GERT GENERATED AIS
TEST TIMES

KOLMOGOROV-SMIRNOV GOODNESS-OF-FIT TEST

TEST DISTRIBUTION - NORMAL (MEAN = 1.1860, STD DEV = 0.5244)

CASES = 25 MAX(ABS DIFF) = 0.1077

K-S Z = 0.538 2-TAILED P = 0.934

n=25; $\alpha=.01$ Lilliefors Table Value = .20

H_0 : Distribution of AIS testing times is log-normally distributed; logarithms of testing times are normally distributed.

H_a : Distribution of AIS testing times is not log-normally distributed; logarithms of testing times are not normally distributed.

Since $.1077 < .20$, cannot reject null hypothesis that AIS testing times are lognormally distributed.

APPENDIX H4

KOLMOGOROV-SMIRNOV GOODNESS-OF-FIT TEST OF THE
Q-GERT GENERATED UNIFORM DISTRIBUTION

KOLMOGOROV-SMIRNOV GOODNESS-OF-FIT TEST

TEST DISTRIBUTION - UNIFORM (RANGE = 0.000 to 1.000)

CASES = 93 MAX(ABS DIFF) = 0.0733

K-S Z = 0.707 2-TAILED P = 0.699

n=93; $\alpha=0.01$

H_0 : VAS assignments are from uniform distribution
in Q-GERT simulation.

H_a : VAS assignments are not from uniform distribu-
tion in Q-GERT simulation.

Since $.699 > \alpha(.01)$, cannot reject that VAS assignments
are uniformly distributed.

APPENDIX H5
HISTOGRAM OF EXPONENTIAL DISTRIBUTION OF
INTERARRIVAL TIMES

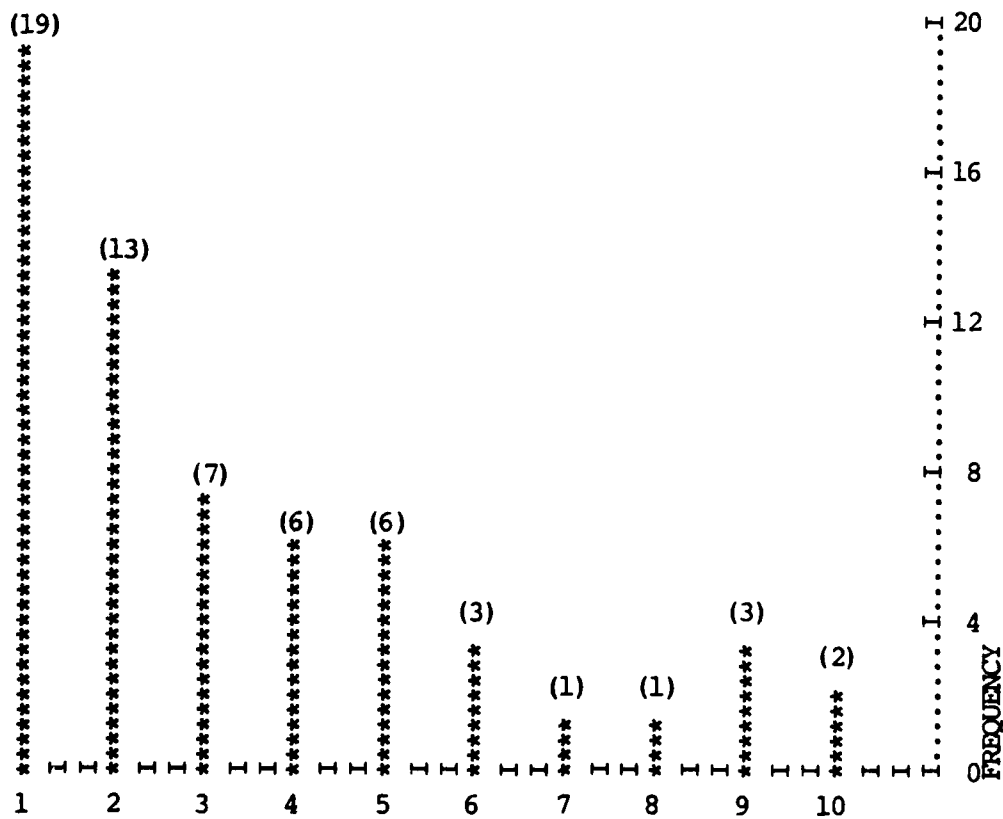

Because the histogram distribution appears exponential, and the values of mean, median and mode fall in that order, the assumption that interarrival times are exponentially distributed cannot be rejected.

APPENDIX I
Q-GERT GENERATED RESPONSE SURFACES

Appendix I is the Q-GERT generated output of the simulation model. Column one shows the run number, each consisting of 30 days of activity. Column two shows the number of AIS test sets for each run, while column three shows the node number of the AIS queue. Columns four, five, and six show the number of LRUs in the AIS queue, and column seven shows the average time a LRU awaits maintenance in the queue.

Run #	# of AIS	Node	Number in Queue			Waiting Time
			Avg	Min	Max	Avg
1	1	14	18.4951	0	32	133.1650
	2	14	1.2931	0	6	7.8901
	3	49	0.1891	0	4	1.2052
2	1	14	15.3759	0	32	106.4483
	2	14	1.2478	0	7	8.1673
	3	49	0.2264	0	3	1.4301
3	1	14	24.1240	0	47	152.3622
	2	14	6.2627	0	14	34.1603
	3	49	0.1129	0	3	0.7196
4	1	14	13.1309	0	26	100.5774
	2	14	0.7088	0	5	5.2073
	3	49	0.0662	0	3	0.4811
5	1	14	19.1835	0	42	120.1054
	2	14	1.3156	0	9	9.1965
	3	49	0.1744	0	5	1.1960
6	1	14	20.1390	0	39	134.2600
	2	14	3.1009	0	12	19.9342
	3	49	0.0989	0	2	0.7421
7	1	14	16.5230	0	27	126.5589
	2	14	0.6433	0	5	4.6320
	3	49	0.2286	0	3	1.5382
8	1	14	21.0297	0	41	141.5084
	2	14	1.2954	0	7	8.4789
	3	49	0.1384	0	3	0.9766
9	1	14	20.9139	0	44	142.0566
	2	14	1.2509	0	5	9.0976
	3	49	0.1317	0	3	0.9775
10	1	14	19.5124	0	35	151.0634
	2	14	0.4769	0	5	3.3998
	3	49	0.1776	0	6	1.3323
11	1	14	23.3834	0	48	154.4595
	2	14	5.5318	0	14	31.1164
	3	49	0.4277	0	4	2.5879
12	1	14	12.4766	0	29	103.2550
	2	14	1.1236	0	5	7.4907
	3	49	0.2214	0	4	1.3509

APPENDIX J
ANALYSIS OF VARIANCE OF RESPONSE SURFACE

Appendix J is divided into three parts. Appendix J1 is a parametric analysis of the response surface shown in Appendix I and was used to determine if parametric statistics could be used to analyze the results. Appendix J2 is a nonparametric test of the response surface shown in Appendix I and was used to determine if nonparametric statistics could be used to analyze the results. Appendix J3 is the analysis of variance test used to determine if the average LRU waiting time was independent of the number of AIS test sets.

APPENDIX J1
ANALYSIS OF VARIANCE AND DUNCAN'S MULTIPLE RANGE
TEST OF RESPONSE SURFACE

TESTS FOR HOMOGENEITY OF VARIANCES

COCHRAN'S C = MAX VARIANCE/SUM (VARIANCES)

= 0.7767, P = 0.000 (approx)

BARTLETT-BOX F = 31.803, P = 0.000

MAXIMUM VARIANCE/MINIMUM = 1282.701

		SUBSET 1	
		GROUP	3 2
MULTIPLE RANGE TEST		MEAN	1.2115 12.3976
DUNCAN PROCEDURE			
RANGES FOR THE .01 LEVEL-		SUBSET 2	
3.87 4.03		GROUP	1
		MEAN	130.4850

H_0 : Variances of average waiting time for service are equal for 1, 2, and 3 servers.

H_a : Variances of average waiting time for service are not equal for 1, 2, and 3 servers.

Since the P values for Cochran's C and Bartlett-Box tests are 0.000, reject null hypothesis that variances are equal. Therefore, ANOVA cannot be used to test the difference of means.

APPENDIX J2
KRUSKAL-WALLIS ANALYSIS OF VARIANCE OF
RESPONSE SURFACE

KRUSKAL-WALLIS ONE-WAY ANOVA

TEST SET	1	2	3
NUMBER	12	141	12
MEAN RANKS	30.50	1.57	6.50

CASES = 36 CHI-SQUARE = 395.034 SIGNIFICANCE = 0.000

n = 36; $\alpha = .01$

H_0 : Distribution of waiting time for service for one, two, and three AIS test sets are equal.

H_a : Distributions of at least two waiting times for service are not equal.

Since $.000 < .01$, can reject that all distributions are equal. Therefore, along with Duncan's Multiple Range Test results it appears as though the distribution for one AIS is not equal to distributions for two and three for waiting time for service.

APPENDIX J3
ONE-WAY ANALYSIS OF VARIANCE OF
RESPONSE SURFACE

ONE-WAY ANALYSIS OF VARIANCE

GROUP	COUNT	MEAN	STANDARD DEVIATION
GRP01	12	130.4850	19.2839
GRP02	12	12.3976	10.3245
GRP03	12	1.2115	0.5384
<u>TOTAL</u>	36	48.0314	60.5668

SELECTED BIBLIOGRAPHY

A. REFERENCES CITED

1. Anderson, David R., Dennis J. Sweeney, and Thomas A. Williams. An Introduction to Management Science Quantitative Approaches to Decision Making. 2d ed. St. Paul MN: West Publishing Company, 1979.
2. Anthony, Robert N., and Regina E. Herzlinger. Management Control in Nonprofit Organizations. Rev. ed. Homewood IL: Richard D. Irwin, Inc., 1980.
3. Barr, Dr. David R. Department of Mathematics, AFIT/EN, Wright-Patterson AFB OH. Course MA 5.35, "Statistics for Logistics Managers II," Class 1982S. Lectures. 5 October through 11 December 1981.
4. Bazorsky, Igor. Reliability Theory and Practice. Englewood Cliffs NJ: Prentice-Hall, Inc., 1961.
5. Bryson, First Lieutenant Gary C., USAF. "Procurement of the Avionics Intermediate Shop." Unpublished research report, unnumbered. Air Force Institute of Technology, AFIT/LS, Wright-Patterson AFB OH, December 1981.
6. Buschagen, Richard G. Former Procurement Contracting Officer, AIS Procurement, Directorate of Procurement, Deputy for F-16, Wright-Patterson AFB OH. Personal interviews conducted intermittently from 3 November to 27 November 1981.
7. Cassity, Colonel James S., USAF. "Systems Acquisition Management," in Managing the Air Force, pp. 175-199. 2d ed. Maxwell AFB AL: AWC/EDRL, 1980.
8. Chase, Richard B., and Nicholas J. Aquilano. Production and Operations Management. 3d ed. Homewood IL: Richard D. Irwin, Inc., 1981.
9. Clark, Lieutenant Colonel Thomas, USAF. Department of Operational Sciences, AFIT/EN, Wright-Patterson AFB OH. Course SM 6.25, "Logistics Systems Analysis and Design," Class 1982S. Lectures. 28 September through 11 December 1981.

10. Cleary, Michael J., and Robert T. Amsden. A Data Analysis Handbook Using the SPSS System. Reynoldsburg OH: Advocate Publishing Group, 1980.
11. Connolly, Ray. "The Pentagon Goes Shopping for Technology," Electronics, June 30, 1981, pp. 88-91.
12. Deputy Chief of Staff, Logistics Operation, HQ AFLC. "Flight Schedule-FY82." HQ AFLC, Wright-Patterson AFB OH, 4 September 1981, pp. 20-37.
13. Dynamics Research Corporation. Automatic Test Equipment (ATE)--Centralized Data System (CDS) Functional Description. DRC Document E-5855U, Wilmington MA, 15 April 1981.
14. Emmelhainz, Captain Larry W., USAF. Assistant Professor of Financial Management, AFIT/LS, Wright-Patterson AFB OH. Course AM 6.02, "Federal Financial Management," Class 1982S. Lectures. 29 March through 11 June 1982.
15. Folkeson, Major John R., USAF. Assistant Professor of Logistics Management, AFIT/LS, Wright-Patterson AFB OH. Course LM 6.15, "Logistics Decision Support Systems." Class 1982S. Lectures. 29 March through 11 June 1982.
16. General Dynamics. F-16 Avionics Intermediate Shop (AIS) Presentation Outline. Fort Worth TX, undated.
17. _____. F-16 Avionics Intermediate Shop, Technical Volume 2, RF Test Station. Fort Worth TX, 17 October 1975.
18. Harrington, Major Thomas C., USAF. Assistant Professor of Logistics Management, AFIT/LS, Wright-Patterson AFB OH. Course SM 5.26, "Quantitative Decision Making," Class 1982S. Lectures. 13 July 1981 through 18 September 1981.
19. Hull, C. Hadlai, and Norman H. Nie. SPSS New Procedures and Facilities for Releases 7-9. New York: McGraw-Hill Book Company, 1981.
20. _____. SPSS Pocket Guide, Release 9. New York: McGraw-Hill Book Company, 1981.

21. Keen, Peter G. W., and Michael S. Scott Morton. Decision Support Systems: An Organization Perspective. Reading MA: Addison-Wesley Publishing Company, 1978.
22. Kirkpatrick, Elwood G. Introductory Statistics and Probability for Engineering, Science, and Technology. Englewood Cliffs NJ: Prentice-Hall, 1974.
23. Lowell, Captain James Russell, USAF. "An Analysis of Air Force Avionic Test Station Utilization Using Q-GERT Modeling and Simulation." Unpublished master's thesis. AFIT/CT/79-265T, Arizona State University, December 1979. AD A091478.
24. Marsh, General Robert T., USAF. "Electronic Trends and Challenges," Air Force Magazine, July 1981, pp. 34-41.
25. Masters, Major James M., USAF. Assistant Professor of Operations Research, AFIT/LS, Wright-Patterson AFB OH. Course AM 5.59, "Life Cycle Cost and Reliability," Class 1982S. Lectures. 4 January through 12 March 1982.
26. McClave, James T., and P. George Benson. Statistics for Business and Economics. Rev. ed. San Francisco: Dellen Publishing Company, 1979.
27. Minton, Chester E. Equipment Specialist, Product Performance System, AFR 66-1, Maintenance Data Collection System, Warner Robins ALC, Robins AFB GA. Telephone interview. 20 October 1981.
28. Nie, Norman H., and others. SPSS, Statistical Package for the Social Sciences. 2d ed. New York: McGraw-Hill Book Company, 1975.
29. Novak, Major Theodore J., Jr., USAF. Division Head, Department of Contracting Management, AFIT/LS, Wright-Patterson AFB OH. Course CM 5.23, "Reliability Improvement Warranty," Class 1982S. Lectures. 21 September through 11 December 1981.
30. Pfaffenberger, Roger C., and James H. Patterson. Statistical Methods for Business and Economics. Homewood IL: Richard D. Irwin, Inc., 1981.

31. Price, Captain Anton J., USAF. Program Manager, F-16 AIS Program, Directorate of Acquisition Logistics, Deputy for F-16, Wright-Patterson AFB OH. Personal interviews conducted intermittently from September 1981 to June 1982.
32. Pritsker, A. Alan B. Modeling and Analysis Using Q-GERT Networks. 2d ed. New York: John Wiley & Sons, Inc., 1979.
33. Reynolds, Professor Daniel E. Assistant Professor, Department of Mathematics, AFIT/EN, Wright-Patterson AFB OH. Course MA 3.65, "Logistics Systems Analysis and Design," Class 1982S. Lectures. 13 July 1981 through 18 September 1981.
34. _____. Assistant Professor, Department of Mathematics, AFIT/EN, Wright-Patterson AFB OH. Course MA 5.25, "Statistics for Logistics Managers," Class 1982S. Lectures. 13 July 1981 through 18 September 1981.
35. Rutledge, Colonel John K., USAF. Director of Acquisition Logistics, Deputy for F-16, Wright-Patterson AFB OH. Personal interviews conducted intermittently from September 1981 to June 1982.
36. Schoderbek, Charles G., Peter P. Schoderbek, and Asterios G. Kefalas. Management Systems Conceptual Considerations. Rev. ed. Dallas TX: Business Publications, Inc., 1980.
37. School of Systems and Logistics. Air Force Institute of Technology (ATC). Compendium of Authenticated Systems and Logistics Terms, Definitions and Acronyms. Wright-Patterson AFB OH, undated.
38. _____. Air Force Institute of Technology (ATC). Life Cycle Costing QMT 3.53 Textbook. Wright-Patterson AFB OH, undated.
39. Shannon, Robert E. Systems Simulation the Art and Science. Englewood Cliffs NJ: Prentice-Hall, Inc., 1975.
40. U.S. Department of the Air Force. Equipment Maintenance. AFR 66-1. Vol. I: "Maintenance Management Policy." Washington: Government Printing Office, 2 January 1980.

41. _____ . Equipment Maintenance. AFR 66-5. Vol. II: "Production Oriented Maintenance Organization." Washington: Government Printing Office, 15 July 1979.
42. Weinroub, Bernard. "Air Force Crying Wolf for Big Gains, Critics Say," Dayton Daily News, April 11, 1982, Section F, p. 1-F.

B. RELATED SOURCES

Aeronautical Systems Division. "ASD Acquisition Management Orientation Course." Course Syllabus. Wright-Patterson AFB OH, 30 November to 4 December 1981.

"Air Force Saves Millions in F-16 Multi-Year Buy," Sky-Wrighter. Wright-Patterson AFB OH Base Newspaper, January 29, 1982, p. 12.

Almassy, Richard, and others. "Preliminary Design and Analysis of an Aircushion Vehicle as an Alternate Aircraft Takeoff System, Volume I." Unpublished executive summary, unnumbered. School of Engineering, Air Force Institute of Technology, Wright-Patterson AFB OH, 8 March 1978. AD C016363L.

_____. "Preliminary Design and Analysis of an Aircushion Vehicle as an Alternate Aircraft Takeoff System, Volume II." Unpublished systems analysis, unnumbered. School of Engineering, Air Force Institute of Technology, Wright-Patterson AFB OH, 8 March 1978. AD C016364L.

_____. "Preliminary Design and Analysis of an Aircushion Vehicle as an Alternate Aircraft Takeoff System, Volume III." Unpublished research report, unnumbered. School of Engineering, Air Force Institute of Technology, Wright-Patterson AFB OH, 8 March 1978. AD B032273L.

_____. "Preliminary Design and Analysis of an Aircushion Vehicle as an Alternate Aircraft Takeoff System, Volume IV." Unpublished research report, unnumbered. School of Engineering, Air Force Institute of Technology, Wright-Patterson AFB OH, 8 March 1982. AD B032274L.

- Annesser, Major James W., USAF. Instructor in Transportation Management, AFIT/LS, Wright-Patterson AFB OH. Course LM 5.40, "Distribution Management," Class 1982S. Lectures. 4 January through 12 March 1982.
- Belden, Colonel David L., and Ernest G. Gammach. Procurement. Industrial College of the Armed Forces, 1973.
- Berman, D. W., and D. R. Farrow. "F-16 Training System Media Report." Unpublished research report, unnumbered. Coursework, Inc., San Diego CA, March 1981. AD A099840.
- Cucchiarella, Claude M., and others. "Investigation of F-16 Landing Gear Alternatives for Operation on Repaired Bomb Damaged Runways, Volume III." Unpublished research report, unnumbered. School of Engineering, Air Force Institute of Technology, Wright-Patterson AFB OH, 10 December 1980. AD B054557L.
- Davis, William R., and John Wysowski. "A Summary and Analysis of the Logistics Support Cost Model Application to the ACF/F-16 Weapon System Acquisition." School of Systems and Logistics, Air Force Institute of Technology, Wright-Patterson AFB OH, June 1979. AD A072592.
- Devers, Waynard C. "Acquisition of USAF Avionics Support Systems." Unpublished research report, unnumbered. Air Command and Staff College, Maxwell AFB AL, May 1981. AD B057539L.
- DiGiovanna, Albert V., and William L. Eischens. "DT&E Reliability and Maintenance Evaluation of the F-16 Aircraft." 6510 Test Wing, Air Force Flight Test Center, Edwards AFB CA, June 1979. AD B039093.
- Doman, Allan M., and Alan G. Dunkerley. "Evaluation of F-16 Subsystem Options Through the Use of Mission Completion Success Probability and Designing to System Performance/Cost Models." School of Engineering, Air Force Institute of Technology, Wright-Patterson AFB OH, September 1975. AD A021263.
- Eggemeter, F. Thomas, and Gary Klein. "Life Cycle Costing of Simulated Versus Actual Equipment for Intermediate Maintenance Training." Unpublished research report, unnumbered. Air Force Human Resources Laboratory, Brooks AFB TX, July 1981. AD A102387.
- Fallows, J. "America's High-Tech Weaponry," Atlantic, May 1981, pp. 21-33.

"Fighter Application Focus Set for Technology Bash,"
Aviation Weekly, March 30, 1981, p. 57.

General Dynamics. Electronics Division. F-16 AIS: Post Award Conference. San Diego CA, 30 March 1976.

_____. Electronics Division. F-16 Avionics Intermediate Shop. San Diego CA, undated.

_____. Electronics Division. F-16 Avionics Intermediate Shop: Attachment 1 (PP of E) Revision A. General Dynamics Document RFP75-0. San Diego CA, 19 January 1976.

_____. Electronics Division. F-16 Avionics Intermediate Shop: Executive Summary. General Dynamics Document RFP 75-07. San Diego CA, 20 October 1975.

_____. Electronics Division. F-16 Avionics Intermediate Shop: Management--Volume 7, Attachment 1 (PP of E). General Dynamics Document RFP 75-07. San Diego CA, 20 October 1975.

_____. Electronics Division. F-16 Avionics Intermediate Shop: Technical--Volume 3, Computers / Inertial Test Station. General Dynamics Document RFP 75-07. San Diego CA, 20 October 1975.

_____. Electronics Division. F-16 Avionics Intermediate Shop: Technical--Volume 4, Processors/Pneumatics Test Station. General Dynamics Document RFP 75-07. San Diego CA, 20 October 1975.

_____. Electronics Division. F-16 Avionics Intermediate Shop: Volume 6--Design Assurance. General Dynamics Document RFP 75-07. San Diego CA, 20 October 1975.

_____. Electronics Division. F-16 Avionics Intermediate Shop: Volume 7--Management. General Dynamics Document RFP 75-07. San Diego CA, 20 October 1975.

_____. Fort Worth Division. AIS Test Station TRU/SRU Utilization Matrix. Fort Worth TX, 9 May 1980.

_____. Fort Worth Division. F-16 Avionics Intermediate Shop: Program Management Reviews. Fort Worth TX, 20 May 1977.

Graves, Samuel R. "A Monte Carlo Risk Analysis of Life Cycle Cost Prediction." Unpublished study, unnumbered. School of Engineering, Air Force Institute of Technology, Wright-Patterson AFB OH, September 1975. AD A021677.

Griffiths, D. R. "F-16 Questioned in Defense Department," Aviation Weekly, August 18, 1980, pp. 92-93.

Gross, James P. "Techniques for Interfacing Multiplex Systems." Unpublished research report, unnumbered. Science Systems, Inc., Huntsville AL, February 1981. AD A101457.

Guerra, Joel A, Andrew J. Lesko, and Jose G. Pereira. "An Operating and Support Cost Model for Avionics Automated Test Equipment." Unpublished master's thesis, School of Systems and Logistics, Air Force Institute of Technology, Wright-Patterson AFB OH, September 7, 1979. AD A075586.

Hite, Michael D. "Weapon System Activation: The Impact of Parallel Site Activations." School of Engineering, Air Force Institute of Technology, Wright-Patterson AFB OH, December 1977. AD A056500.

Hoel, O. Bernell. Chief, Acquisition Projects Division, Directorate of Acquisition Logistics, Deputy for F-16, HQ ASD/YPAP. Letter, subject: ATE/CDS "D" Level Initial Working Group, to See Distribution, 19 May 1981.

_____. Chief, Acquisition Projects Division, Directorate of Acquisition Logistics, Deputy for F-16, HQ ASD/YPAP. Letter, subject: ATE/CDS "O" and "I" Level Functional Description Finalization Meeting, to See Distribution, undated.

Hynes, Cecil V. "Taking a Look at the Request for Proposal," Defense Management Journal, October 1977, p. 27.

Institute of Defense Analyses. Program Analysis Division. Built-in-Test Equipment Requirements Workshop: Workshop Presentation. IDA Paper P-1600. Arlington VA, August 1981.

Johnson, James C., and Donald F. Wood. Contemporary Physical Distribution and Logistics. 2d ed. Tulsa OK: Pennwell Publishing Company, 1982.

Koegel, Thomas R., and Nathan B. Mills, Jr. "An Analysis of Decision Criteria for the Selection of F-16 Reliability Improvement Incentive Alternatives." Unpublished research report, unnumbered. School of Systems and Logistics, Air Force Institute of Technology, Wright-Patterson AFB, OH, September 1975. AD 14786.

Lee, Lamar, Jr., and Donald W. Dobler. Purchasing and Materials Management, Text and Cases. 3d ed. New York: McGraw-Hill Book Company, 1977.

Maxfield Associates, Ltd. F-16 Lessons Learned Through the F-16 Program by Virtue of the Multinational Involvement--A U.S. Government Perspective. Alexandria VA, April 1980.

_____, and Peat, Marwick, Mitchell, & Company. F-16 Program Lessons Learned Study: Executive Summary, Alexandria VA, April 15, 1980.

McGregor, D. W., and others. "Analysis and Evaluation of Advanced Aircraft, Volume I." Unpublished executive summary, unnumbered. General Dynamics Corporation, Fort Worth TX, June 1980. AD C025544.

_____. "Analysis and Evaluation of Advanced Aircraft, Volume II." Unpublished executive summary, unnumbered. General Dynamics Corporation, Fort Worth TX, June 1980. AD C025545.

Miller, T. M. "Improving Diagnostic Systems: A Conceptual Approach." Unpublished report, unnumbered. Air Force Human Resources Laboratory/LRLA, Wright-Patterson AFB OH, 5 July 1981.

"New Technology Guides Avionics Work," Aviation Week, January 29, 1979, pp. 183-185.

Ostrofsky, Benjamin. "Application of a Structured Decision Process for Proper Inclusion of Human Resources in the Design of a Power Unit Support Stand." Unpublished report, unnumbered. Houston University, Houston TX, September 1978. AD A069978.

Pate, John L. "Role of the Deputy Program Manager for Logistics in USAF F-16 Systems Program Office." Unpublished study, unnumbered. Defense Systems Management School, Fort Belvoir VA, May 1975. AD A028650.

Peat, Marwick, Mitchell & Company. F-16 Program Lessons Learned Study--U.S. Industry, European Participating Governments and European Participating Industry Perspectives, 22 May 1980.

Senseney, Gary L. "Expansion and/or Consolidation of Base Level Repair of F-100 Engine." Unpublished research report, unnumbered. Air Command and Staff College, Maxwell AFB AL, May 1976. AD B011904L.

U.S. Department of the Air Force. Aeronautical Systems Division. Deputy for F-16, Directorate of Acquisition Logistics. "Avionics Facility Planning Guide." ASD/YPAA, Wright-Patterson AFB OH, 1 February 1978.

_____. Air Force Systems Command, Aeronautical Systems Division. Contract F-33657-75-C-0310 P00517, with General Dynamics Corporation. Wright-Patterson AFB OH, 29 December 1978.

_____. Air Force Systems Command Aeronautical Systems Division. Contract F-33657-80-G-0038 004, with General Dynamics Corporation. Wright-Patterson AFB OH, 1978.

_____. Message--Advance Notification Information to Office of Secretary of the Air Force, Wright-Patterson AFB OH, 1978.

"U.S. Tactical Air Readiness Kit," Aviation Week, April 30, 1979, p. 29.

"USAF Gives Top Fund Priority to B-1; F-16, AWACS Follow," Aviation Week, January 26, 1976, pp. 21-24.

"USAF Returns F-16s to Flight Status--Electrical System Problems Remedied," Aviation Week, August 24, 1981, pp. 16-17.

Wagner, F. C., and W. E. Willard. "Low Maintenance Hydraulic Accumulator." Unpublished research report, unnumbered. Boeing Military Airplane Company, Seattle WA, June 1981. AD A103947.

DATE
ILME