

AD-A123 973

THE DESIGN DEVELOPMENT AND TEST OF A PULSE MONITOR
SYSTEM(U) TRI-CON ASSOCIATES INC CAMBRIDGE MA
C G KUCZUN 19 NOV 82 C-197 AFGL-TR-82-0339

1/1

UNCLASSIFIED

F19628-80-C-0164

F/G 20/3

NL

| | | | | | | | | | | | | | |
|--|--|--|--|--|--|--|--|--|--|--|--|--|--|
| | | | | | | | | | | | | | |
| | | | | | | | | | | | | | |
| | | | | | | | | | | | | | |
| | | | | | | | | | | | | | |
| | | | | | | | | | | | | | |

END

FORMED

DEC

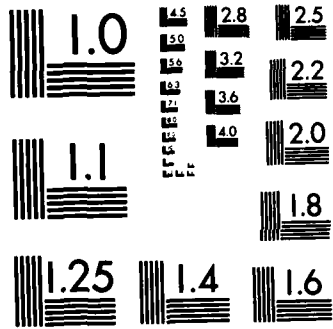

MICROCOPY RESOLUTION TEST CHART
NATIONAL BUREAU OF STANDARDS-1963-A



DA FORM 101-100

**THE DESIGN, DEVELOPMENT AND TEST
OF A PULSE MONITOR SYSTEM**

Author: R. A. Anderson
TRAI-COM ASSOCIATES, INC.,
755 Cambridge Avenue
Cambridge, Massachusetts 02138

November 19, 1962

FINAL REPORT: Period Covered 3 August 1961
27 August 1962



Approved for Public Release, Distribution Unlimited

AIR FORCE ELECTRONICS LABORATORY
AIR FORCE SYSTEMS COMMAND
WITTEL SPRING AIR FORCE
WINDSOR, MASSACHUSETTS 01731

DA 123973

UNCLASSIFIED

SECURITY CLASSIFICATION OF THIS PAGE (When Data Entered)

| REPORT DOCUMENTATION PAGE | | READ INSTRUCTIONS BEFORE COMPLETING FORM |
|--|---|--|
| 1. REPORT NUMBER AFGL-TR-82-0339 | 2. GOVT ACCESSION NO. A123973 | 3. RECIPIENT'S CATALOG NUMBER |
| 4. TITLE (and Subtitle) THE DESIGN DEVELOPMENT AND TEST OF A PULSE MONITOR SYSTEM | | 5. TYPE OF REPORT & PERIOD COVERED Final Report 1 August 1980-31 August 1982 |
| 7. AUTHOR(s) Chester G. Kuczun | | 6. PERFORMING ORG. REPORT NUMBER C-197 |
| 9. PERFORMING ORGANIZATION NAME AND ADDRESS TRI-CON ASSOCIATES, INC. 765 Concord Avenue Cambridge, MA 02138 | | 8. CONTRACT OR GRANT NUMBER(s) F19628-80-C-0164 |
| 11. CONTROLLING OFFICE NAME AND ADDRESS AIR FORCE GEOPHYSICS LABORATORY HANSCOM AIR FORCE BASE, MASSACHUSETTS 01731 Monitor; William Kaneshiro/PHK | | 10. PROGRAM ELEMENT, PROJECT, TASK AREA & WORK UNIT NUMBERS 62101F 766109AE |
| 14. MONITORING AGENCY NAME & ADDRESS (if different from Controlling Office) | | 12. REPORT DATE 9 November 1982 |
| | | 13. NUMBER OF PAGES 55 |
| | | 15. SECURITY CLASS. (of this report) Unclassified |
| | | 15a. DECLASSIFICATION/DOWNGRADING SCHEDULE |
| 16. DISTRIBUTION STATEMENT (of this Report) Approved for Public Release: Distribution Unlimited | | |
| 17. DISTRIBUTION STATEMENT (of the abstract entered in Block 20, if different from Report) | | |
| 18. SUPPLEMENTARY NOTES | | |
| 19. KEY WORDS (Continue on reverse side if necessary and identify by block number) | | |
| 20. ABSTRACT (Continue on reverse side if necessary and identify by block number) The objective of this contract was to design instrumentation to sense electrical breakdown phenomena on or near the surface of a spacecraft due to environmental or spacecraft surface charging induced by natural means and/or by charge emission by on-board devices. These discharges were characterized by measuring their polarity, peak amplitude, maximum duration, number, and total energy for successive one second sample intervals. | | |

DD FORM 1 JAN 73 1473

EDITION OF 1 NOV 65 IS OBSOLETE

UNCLASSIFIED

SECURITY CLASSIFICATION OF THIS PAGE (When Data Entered)

TABLE OF CONTENTS

| | Page |
|---|------|
| 1.0 OBJECT OF CONTRACT | 1 |
| 2.0 DESIGN PHILOSOPHY | 2 |
| 3.0 PMS SPECIFICATIONS | 4 |
| 4.0 BLOCK DIAGRAM AND THEORY OF OPERATION. | 5 |
| 4.1 Input Amplifier Circuits. | 5 |
| 4.2 Peak Amplitude Circuits | 6 |
| 4.3 Total Energy Circuits | 7 |
| 4.4 Total Count and Maximum Pulse Width Circuits. | 8 |
| 4.4.1 Total Count Circuits | 9 |
| 4.4.2 Maximum Pulse Width Circuits | 9 |
| 4.4.3 Dead Time Circuit. | 11 |
| 4.4.4 Voltage Comparator Threshold Bias Circuit. | 12 |
| 4.5 Timing Circuits | 13 |
| 5.0 MECHANICAL OUTLINE DRAWINGS. | 13 |
| 6.0 INTERFACE WIRING TABLES. | 14 |
| 7.0 PMS GROUND SUPPORT EQUIPMENT | 14 |
| 8.0 PMS CALIBRATION DATA | 15 |
| 8.1 Bipolar Electrometer Calibration. | 15 |
| 8.2 Total Energy Calibrations | 15 |
| 8.3 Pulse Amplitude Calibration | 16 |
| 8.4 Maximum Pulse Width Calibration | 16 |
| 8.5 Dead Time Calibration | 17 |
| 9.0 FUTURE PROGRAM | 18 |
| 9.1 Electrical Calibration. | 18 |
| 9.2 Laboratory Discharge Sources. | 19 |
| 9.3 Probe Geometry. | 20 |

LIST OF FIGURES

| | Page |
|--|------|
| FIGURE 1 | |
| Waveforms Positive Peak Amplitude PA+ | 21 |
| FIGURE 2 | |
| Waveforms Positive Total Energy TE- | 22 |
| FIGURE 3 | |
| Waveforms Positive Total Count TA+ | 23 |
| FIGURE 4 | |
| Waveforms Maximum Positive Pulse Width PW+ | 24 |
| FIGURE 5 | |
| Bipolar Electrometer Calibration | 25 |

LIST OF TABLES

| | Page |
|--|------|
| JR INPUTS FROM ROCKET. | 26 |
| JA ANALOG OUTPUTS. | 27 |
| JP PROBE ELECTRONICS | 28 |
| BIPOLAR ELECTROMETER CALIBRATION | 29 |
| TOTAL ENERGY (+) TE+ CALIBRATION | 30 |
| TOTAL ENERGY (-) TE (-) CALIBRATION. | 31 |
| TOTAL ENERGY (+) TE+ CALIBRATION | 32 |
| TOTAL ENERGY (+) TE+ CALIBRATION | 33 |
| PEAK AMPLITUDE | 34 |
| MAXIMUM PULSE WIDTH (+) PW+ CALIBRATION. | 35 |
| THRESHOLD BIAS CALIBRATION | 36 |
| DYNAMIC THRESHOLD BIAS CALIBRATION | 37 |
| DYNAMIC THRESHOLD BIAS CALIBRATION | 38 |
| DEAD TIME CALIBRATION. | 39 |



| | |
|--------------------|-------------------------------------|
| Accession For | |
| NTIS GRA&I | <input checked="" type="checkbox"/> |
| DTIC TAB | <input type="checkbox"/> |
| Unannounced | <input type="checkbox"/> |
| Justification | |
| By | |
| Distribution/ | |
| Availability Codes | |
| Dist | Avail and/or Special |
| A | |

LIST OF DRAWINGS

| | Page |
|---|------|
| D-3057 PULSE MONITOR SYSTEM BLOCK DIAGRAM | 40 |
| C-2091 Pulse Monitor System Pulse Amp | 41 |
| D-2087 PULSE MONITOR SYSTEM TOTAL ENERGY-MAX. PULSE AMP- MAX. PULSE WIDTH | 42 |
| C-2089 PULSE MONITOR SYSTEM TOTAL ENERGY-MAX. PULSE AMP- MAX PULSE WIDTH | 43 |
| D-2085 PULSE MONITOR SYSTEM-COMMANDS-V/C BIAS CONTROL GATES | 44 |
| D-2083 PULSE MONITOR SYSTEM-TOTAL ENERGY-MAX AMP-MAX WIDTH | 45 |
| C-2097 PULSE MONITOR SYSTEM-PULSE AMP DETAIL ASSEMBLY | 46 |
| C-2095 PULSE MONITOR SYSTEM-MAIN ELECTRONICS OUTLINE | 47 |
| C-3034 PULSE MONITOR SYSTEM - GSE FRONT PANEL | 48 |
| B-3033 PULSE MONITOR SYSTEM - GSE CIRCUIT DIAGRAM | 49 |

1.0 OBJECT OF CONTRACT

The objective of the Pulse Monitor System (PMS) is to sense the electrical breakdown phenomena on or near the surface of spacecraft and to characterize them by measuring their polarity, amplitude, duration, total integrated energy, and number occurring above an adjustable threshold level for a particular sample interval. In addition, the net charged particle flux to the probe is measured with a bipolar electrometer amplifier.

This contract called for the design, fabrication, and testing of breadboard circuits, a flight prototype and laboratory ground support system to accomplish this objective.

2.0 DESIGN PHILOSOPHY

Electrical breakdowns can occur within, on the surface of, and outside conventional orbiting spacecraft. Usually these breakdowns are limited to random pulse bursts in the geiger regime or Townsend discharges because of limiting densities, voltage gradients, and ionizing mechanisms. In this case these neighboring environments are all being drastically changed by carefully programmed on board disturbances. These include significant localized densities of neutral, positive, and negative particles. These particles are disbursed with geometries and energy levels characteristic of these sources. Their trajectories are further influenced by the relative vehicle charge and the existing magnetic fields. The end results could be described as potential 'messes'. However, the disturbances from within will be programmed as to their magnitude and

documented. In addition numerous monitors will be used to measure many significant parameters of the vehicle, its attitude, and other neighboring environmental events. Correlation of the data of these monitors should yield a first go-around footprint of the stimulated electrical breakdowns.

Depending on nature, magnitude, duration, (plus umteen other variables) of the onboard stimulated disturbances, the resulting electrical discharges could range from the geiger regime discharges which are characterized by current flows of 10^{-15} amperes, Townsend discharges of 10^{-12} amperes, self-sustained discharges of 10^{-6} amperes, Corona discharge of 10^{-4} amperes and through arcs of tens of amperes. Where this discharge will occur relative to the PMS probe is unpredictable. The nature of the coupling to the probe (electromagnetic, capacitive, conductive) is equally unpredictable. However, the PMS "probe is to be of sufficient size (length and width) to provide the PMS with adequate signal, yet be of a size which is compatible to satellite operations. A length of 1 meter and an area of 10 Cm^2 should be compatible with most satellites and spacecraft and be a design aim". The exact transfer characteristic will certainly be made possible in the laboratory with semi-controlled discharges and known orientation of the PMS probe with respect to the discharges.

However, the specifications of the electronics which follows the probe will be known to a relatively high degree of precision: the capacitance of the probe to the spacecraft, the time constant of all circuits, the gain of all circuits, the

threshold of all circuits, the dynamic range of all circuits, the sampling time of all measurements, the polarity of each event at the input, and the dead time following each event. The goal was to make realistic but reasonable specifications for the following parameters to be measured and along with numerous ground commands make possible the operation of the PMS in various modes resulting in a flexibility so that changes can be made after laboratory evaluation tests or flight performance observations.

Basically the PMS consists of a single probe mounted external to the spacecraft and connected simultaneously to a bipolar DC logarithmic amplifier and an AC coupled pulse amplifier. The output of the pulse amplifier is separated into two simultaneously operating channels (positive and negative) and the following signal conditioning is performed on each channel during a one second sampling time.

Peak Amplitude
Total Energy
Total Number Pulses Above
Programmed Threshold
Maximum Pulse Width Above
Programmed Threshold

Some measurements, such as the pulse width, are inherently analog outputs, where as the total count measurement output is inherently digital in nature. However, all outputs have 0 to +5 volt analog outputs available for telemetry or GSE use. Outputs are available during the complete sample interval following the one during which the measurement was made.

3.0 PMS SPECIFICATIONS

| | | |
|--|---|--------------|
| a. Sample Interval | 1.0 | second |
| b. Sample Duty Cycle | ~ 99% | |
| c. Maximum Pulse Amplitude | ± 5.0 | volts |
| d. Minimum Pulse Amplitude | ± 0.1 | volts |
| e. Maximum Pulse Width | 40 | μ second |
| f. Minimum Pulse Width | 1.0 | μ second |
| g. Total Energy (0.05 volts out) | 1.0 volt | μ second |
| h. Total Energy (5.0 volts out) | 100 volt | μ second |
| i. Maximum Dead Time (Programmable) | 1280 | μ second |
| j. Minimum Dead Time (Programmable) | 10 | μ second |
| k. Maximum Total Count Capacity (Output 5.0 volts) | 256 events for (+) & (-) events | |
| l. Minimum Total Count Capacity (Output 0.05 volts) | 2 events for (+) & (-) events | |
| m. Overflow Count Inhibited at | 256 counts for (+) & (-) events | |
| n. Electrometer Sensitivity | $\pm 10^{-11}$ to $\pm 10^{-5}$ amperes | |
| o. Size | | |
| Main Electronics | 8.125 inches long-6.187 inches wide - 4.625 inches high 232.5 inches ³ | |
| Pulse Amplifier | 5.5 inches long-3.45 inches wide -1.3 inches high 24.5 inches ³ | |
| p. Input Power Supply | 28.0 \pm 4 | volts |
| q. Input Current | 0.60 | amperes |
| r. Input Power | 14.4 to 19.2 | watts |
| s. Weights | | |
| Main Electronics | 5 lbs. 4 oz. | |
| Pulse Amplifier | 10 oz. | |
| TELEMETRY INTERFACE | | |
| a. Signal Outputs | 0.0 to + 5.0 volts full scale limited at - 0.7 and + 5.7 volts | |
| Output Impedance | 10K | |

b. Input Commands

Threshold Bias

4 Latching Relays
8 Commands - + 28 volts
16 Levels

Dead Time

3 Latching Relays
6 Commands - + 28 volts
8 Dead Times

4.0 BLOCK DIAGRAM AND THEORY OF OPERATION

a. The block diagram of the PMS is shown in Drawing D-3057. The PMS system consists of 5 circuit types. Four of these circuits are common or singular to the PMS. One is the pulse amplifier (U1) and the popular logarithmic amplifier (U2). Another is the timing circuit consisting of U33 - U36 and 3 inverters. Another block comprises the ± 15 volt and +5 volt power supplies (not shown). The 4th common block is the Dead Time circuit (U14 - U16). The parallel circuits measure peak amplitude (U3 - U4 for (+) amplitude and U27 - U28 for (-) amplitude); the total energy (U5 - U6 for (+) pulses and U25 - U26 for (-) pulses); total pulses (U17 - U20 for (+) pulses and U21 - U24 for (-) pulses), and maximum pulse width (U8 - U10 for (+) pulses and U30 - U32 for (-) pulses).

4.1 Input Amplifier Circuits

The probe is AC coupled via C1 and R1 to the input of the pulse buffer U1 and DC coupled via R3 to the input of the bipolar logarithmic amplifier U2 as shown in C-2091. Both amplifiers are protected from high level input transients

by resistor - diode circuits.

The pulse buffer (National LH 0033) is a unity gain, high input impedance (10^{10} ohms), low output impedance (4 ohms), wide bandwidth (200 MHz) amplifier.

The bipolar electrometer amplifier uses an Intersil type ICH 8400A operational amplifier and a type 2N5119 transistor for the negative logarithmic feedback element and a type 2N2920A for the positive feedback element. $E_o(-)$, the electrometer output inherently goes from 0 to +5 for negative input currents. U3 is a unity gain inverting amplifier which is used to condition the $E_o(+)$ output for positive input currents. As with all TM outputs, these outputs are protected with resistor-zener diode circuits as shown.

4.2 Peak Amplitude Circuits

As shown in the Block Diagram, D-3057, the output of the pulse buffer goes to the input of (+) peak amplitude circuit represented by CR1 and two cascaded sample and hold circuits. The (-) peak amplitude circuit is identical to the (+) one except for the input polarity discrimination of CR4 and the inversion by an output buffer to make the output compatible with the 0 to +5 volt TM requirement. The detailed schematics for these peak amplitude circuits are shown in the lower half of D-2087.

The performance of the (+) peak amplitude circuit is demonstrated by the waveforms in Figure 1 and the ballooned test points in the Block Diagram D-2087. A chain of input pulses

(B) is assumed (pulses 1, 3, 4, 6, 7, 9). Input pulse 1, being positive is peak detected and held by CR1 and U3. This results in the output of U3 going from 0 to level 2 as shown in Figure 1. Pulse 3 being negative is polarity discriminated and results in no change to waveform H. The next pulse 4, being positive and greater in amplitude than the previous positive pulse, 1, results in an updating of H to amplitude 5. The next pulse, 6, being less than the maximum preceding one results in no change. Pulse 7 in the illustration is the last largest one in the sample interval and it results in level 8 in waveform H. At the end of the sample interval the set pulse S updates the S/H of U4 changing waveform J from level 11 (the maximum peak amplitude observed during the previous sample interval) to level 12. The reset pulse R which follows resets the peak detector to zero and the next sample interval is started.

4.3 Total Energy Circuits

As shown in the Block Diagram D-3057 the output of the pulse buffer goes to input of (+) total energy circuit represented by CR2 followed by an integrator (R3, C2 and U5) and a S/H represented by U6. The (-) total energy is identical to the (+) one except for the input polarity discrimination of CR3 and the inversion by an output buffer. The detailed schematics for these total energy circuits are shown in C-2089.

The performance of the (+) total energy circuit is demonstrated by the waveform in Figure 2 and the Block Diagram D-3057 ballooned test points. A chain of input pulses B is assumed (pulses 1, 3, 4, and 6) occurring during the 1 second sampling interval. The first pulse 1, being

positive is integrated by U5 to result in a change in waveform J from 0 to level 2. The next pulse 3 being negative is polarity discriminated by CR2 and results in no change in waveform J. The next two pulses 4 and 6 each add to the level of waveform J according to their respective areas resulting in level 7. At the end of the sample interval the set pulse S updates the S/H of U6 changing waveform K from level 8 (the total (+) energy observed during the previous sample interval) to level 9 corresponding to level 7. The reset pulse, R, which follows, resets the total energy integrator U5 to zero and the next sample interval is started.

4.4 Total Count and Maximum Pulse Width Circuits

Referring to Block Diagram D-3057, it is seen that the output of pulse buffer goes to the (+) and (-) voltage comparators represented by U12 and U13 respectively. A characteristic of these comparators is that for input pulses which exceed a set positive bias for the (+) comparator or a set negative bias for the (-) comparator their outputs go rail to rail and in the same sense. Two of the characteristics of each of these comparators are controlled by other circuits. One characteristic, the threshold bias is controlled by programmable bias circuits shown as U11 in the Block Diagram D-2085 in detail and whose operation is described in 4.4.4. The other, a dead time circuit inhibits both voltage comparators for all input amplitudes after the trailing edge of the first input pulse to either comparator for a particular micro-second interval. This inhibit interval is programmable, shown as U14 and U15 in the Block Diagram D-3057, given in detail in D-2083 and described in 4.4.3.

4.4.1 Total Count Circuits

The performance of the (+) total count circuits is demonstrated by the waveform in Figure 3 and the Block Diagram D-3057 ballooned test points. The action of the (-) total count circuits is identical. A chain of input pulses B is assumed to occur during the 1 second sampling interval. All the positive pulses above the set threshold level TS are ANDED with the sample gate ST and appear at waveform F. These pulses are totalized in the 8 bit accumulator U18. At the end of the sample interval the set pulse S transfers the totalized count from these totalizing registers to the 8 bit latch circuits U19. The information in these registers is digital-to-analog converted to give the waveform G by U20. The reset pulse R which follows resets the totalizing counters to zero and the next sample interval is started. The overflow inhibit capability is shown in D-2083. When the totalized count reaches 255 the counters are inhibited from accepting any additional counts by action of the gating action of U10.

4.4.2 Maximum Pulse Width Circuits

The performance of the (+) maximum pulse width circuits is demonstrated by the waveforms in Figure 4 and the Block Diagram D-3057 ballooned test points. The action of the (-) maximum pulse width circuit is identical. A chain of input pulses B (1, 3, 4, 5, 7, 9), is assumed for the sample interval. Waveform C the output of the voltage comparator illustrates the polarity discrimination, the threshold discrimination, and the dead time inhibiting of the

voltage comparators. It will be noted that pulse 3 which is negative produces no output on waveform C. Pulses 1, 5, and 7 which exceed threshold bias TS do result in outputs at waveform C (2, 6, 8) with widths proportional to the rising and falling crossovers at the threshold bias level. Pulse 4 which does not exceed the threshold bias TS does not produce an output at waveform C. Waveform E shows the dead time gates generated at trailing edges of each pulse which appears at waveform C. These dead time gates are all the same width. It will be noticed that pulse 9 while it exceeds the threshold bias TS but occurs during the dead time following pulse 7 is inhibited and results in no output pulse at waveform C.

The (+) maximum pulse width circuits are shown as U8, U9, and U10 in the Block Diagram D-3057, in detailed schematics as U11 on D-2083 plus U1, U2A, and U3 on D-2087. Basically the circuit is an integrator (R3, C3) followed by 2 cascaded sample and holds, S/H. The action is explained by reference again to the waveforms in Figure 4. Each pulse output of the voltage comparator (waveform C) (pulses 2, 6, and 8) is successively integrated by U8 in Block Diagram D-3057 and held up for the duration of the dead time as shown in waveform L. Since the amplitudes of the pulses in the pulse train waveform B that result in output pulses B are normalized in amplitude the output of the integrator U8 will be proportional solely to the pulse width as illustrated. The integrated pulse shapes at waveform L become the inputs to the first peak sample and hold U9. The output of U9, in waveform M gives an output 15 for the first pulse 12. This level is sustained as

shown until pulse 13 appears. Since pulse 13 is greater than pulse 12 the level 15 is increased to level 16. This level is sustained until the end of the sample interval since no larger amplitude pulses occur. Pulse 14 which follows pulse 13 being smaller than pulse 14 has no effect on waveform M.

The waveform M is applied as an input to the second sample and hold U10. When the set pulse S occurs at the end of the sample interval this S/H is updated as waveform N - from level 17 which corresponded to the maximum pulse width measured during the preceding sample interval to level 18 corresponding to level 16 in waveform M during this sample interval. Waveform O is the inverted waveform N to make the output 0 to +5 volts for TM.

4.4.3 Dead Time Circuit

The dead time circuit schematic is shown in D-2083 and consists of NOR gate U4-1, monostable multivibrator U3, an 8 channel analog switch U15, timing capacitor C2, and timing resistors R3 through R10. The object of the dead time circuit is to generate a gate at trailing edge of either output pulse from voltage comparators U1 and U2. The duration of this gate is command programmable for 8 logarithmically related values. The gate is applied as an inhibit signal to both voltage comparators and prevents any outputs from these comparators during the gate. If a positive pulse appears at output of inverters U12C or U4B the output of NOR gate is a negative pulse. The monostable multivibrator U3 is wired to trigger on a positive going edge which is the trailing edge of the pulse. The generated gate is applied to inhibit input Pin 8 of the voltage comparators U1

and U2. The duration of the gate is determined by C2 and one of the resistors R3 to R10 connected to ground by the 8 channel analog switch U15. The resistor is selected by a binary coded set of voltages applied to DA, DB, and DC - inputs to the switch U15. These signals are 5 volt signals established by 3 latching relays K5, K6, K7 as shown on the Diagram D-2085. The latching relays are in turn set or reset by 6 commands I, J, K, L, M, N on the satellite.

4.4.4 Voltage Comparator Threshold Bias Circuit

The object of the threshold bias circuit is to generate 16 positive and negative logarithmically related voltages to be applied to the voltage comparators U1 and U2 in D-2083. These 16 voltage levels are to be command programmable by the satellite. The detail circuit is shown in the Circuit Diagram D-2085. It consists of 4 latching relays K1 through K4; a 4 pole, single throw FET switch, U8; and 5 operational amplifiers, U9A - U9D and U7A.

The basic design of the circuit is the use of the 4 operational amplifiers each acting as a multiplier to synthesize the required logarithmic function. In the circuit referenced with all the feedback switching controlled by U8A through U8D open the cascaded gain of the amplifiers is one. Binary switch closures of A through D provide multiplier gain changes of 0.78, 0.612, 0.374, and 0.139. These gain changes permit the realization of adjacent ratios of approximately 1.0, 0.79, 0.61, 0.48, 0.38, 0.29, 0.23, 0.18, 0.14, 0.11, 0.085, 0.068, 0.053, 0.04, 0.033, and .025. These multipliers are applied to the input voltage developed by the resistor divider of R26 and R27 across the +5 voltage bias. The unity gain inverter amplifier U71 is used to develop the opposite polarity threshold bias.

4.5 Timing Circuits

The Set, S; Reset, R; and Sample Time, ST gates generated in the PMS are shown as a timing diagram at the bottom of the Block Diagram D-3057. The detailed schematic is shown in D-2085.

The one Hz system oscillator pulse is generated by comparator U2 operated as an oscillator. It is a free-running oscillator but can be synchronized by the on board satellite clock having any interval less than one second by a pulse train through the pulse follower U7. The output of the system oscillator as used to trigger monostable oscillator U3A to generate the Set S (+) and S (-) pulses. The output of the Set S (-) is used to trigger two additional monostable oscillators U3B and U5A. The outputs of U3B are Reset pulses R (+) and R (-). The output of U5A is a 150 μ second pulse to be used as a Read pulse to interrogate all the A/D converters at the output of all analog TM signals if they were to be incorporated sometime downstream. The Set and Reset gated are NORed by U6A for the Sample Time ST.

5.0 MECHANICAL OUTLINE DRAWINGS

The outline drawing of the PMS Pulse Amplifier is shown in C-2097. It has a volume of approximately 24.5 inches³ and weighs 10 oz. The outline drawing of the main electronics is shown in C-2095. It has a volume of approximately 232 inches³ and weighs 5 pounds.

6.0 INTERFACE WIRING TABLES

There are 3 cable harnesses required between units of the PMS and from the satellite to the PMS. The JR connector, Table #1, (a 2DA31P) is used to interface with the satellite for inputs to the PMS. It has the +28 power input, the 6 Dead Time Commands, and the 8 Threshold Bias Commands. The JA connector, Table #2, (a 2DE19S) is used to interface with the satellite with the PMS outputs to telemetry. It has the positive and negative analog measurement outputs for the Electrometer, Total Energy, Total Count, Peak Amplitude, and Pulse Width plus the two analog ladder signals to indicate the operating Threshold Bias and Dead Time that the PMS is operating in. The JP connector, Table #3, (a DAM-11 WIP) is used to interface between the Pulse Amplifier and the Main Electronics Unit. It has + and - 15 volt power required and the electrometer and pulse amplifier outputs.

7.0 PMS GROUND SUPPORT EQUIPMENT

The front panel of PMS GSE is shown in C-3034. The GSE schematic is shown in B-3033 with an external +28 volt power supply having a one amp rating it will exercise the PMS in the laboratory. The GSE monitors the current, normally 600 ma drawn by the PMS. This current does not change significantly for all modes of operation except for transient moments when Dead Time or Threshold Bias commands are executed. The PMS - GSE has 2 signal monitor meters. Each monitor can select one of 12 outputs of the PMS measurement outputs - positive and/or negative analog outputs of Electrometer readings, Total Energy, Total Count, Peak Amplitude, and Maximum Pulse Width plus the Analog Ladders for Threshold Bias and Dead Time. The Dead Time Command is simulated by a 8 position thumbwheel switch plus a momentary contact Execute switch. The Threshold Bias Command is simulated by a 16 position thumbwheel switch plus a corresponding Execute switch.

A 25 pin connector (DBM 25P) is also incorporated to permit simultaneous remote readout of all 12 outputs continuously. The plus and minus 15 volt supplies of the PMS are also available for monitoring or to use externally.

8.0 PMS CALIBRATION DATA

Table #4 through #14 illustrate the scale factor and dynamic range of the PMS in the measurement of the DC current input, the total energy, pulse width, and pulse amplitude characteristics of the input voltage to the PMS.

8.1 Bipolar Electrometer Calibration

The bipolar electrometer calibration is given in Table #4 and plotted in Figure 5. The calibration for positive and negative inputs are almost identical. Each output represents a slope of approximately 0.75 volts per decade of input current. The output response time at 10^{-10} amperes is 20 milliseconds and less than 10 microseconds at 10^{-5} amperes. The scale factor can easily be changed at the low sensitivity end by changing the beta of the feedback networks in the logging circuits. However, the more sensitive limit for this circuit has been realized and greater sensitivity could not be realized because of component and other leakages at the input of the amplifier.

8.2 Total Energy Calibrations

Some total energy calibrations are illustrated in Tables #5 through 8. The measurements were taken for constant amplitude and constant width pulses. The duty cycle was changed by

varying the pulse separation. The data demonstrates a dynamic range of approximately 20 to 1 over the telemetry range of 0.05 to 5.0 volts with some variation for the same duty cycle but different pulse widths and separations.

The scale factor for this measurement can be altered by changing the first integration time constant (R1 - C1 and/or R2 - C3 in total energy Schematic C-2089). Longer time constants are best accomplished by increasing the capacitance and shorter time constants by reducing the resistance. The dynamic range is largely compromised by the threshold characteristics of input polarity discriminating diodes. It could be enhanced by using gated FET switches in place of the diodes.

8.3 Pulse Amplitude Calibration

A typical peak amplitude calibration is shown in Table #9. It demonstrates a dynamic range of approximately 20 to 1 with a maximum input limit of about 5.0 volts. Reducing the scale factor is made difficult because of the finite dynamic range of the input pulse buffer U1 in C-2091. Increasing the scale factor could be done by increasing the gain of the integrating buffers U2C and/or U2D in Schematic D-2087.

8.4 Maximum Pulse Width Calibration

The pulse width as measured as a function of threshold bias TS is illustrated in Table #10. With a unipolar

triangular waveform as shown (100 μ seconds at the base and 2.0 volts amplitude) the pulse width output voltage changes linearly with the bias voltage.

The threshold bias is the voltage applied to both positive and negative voltage comparators to amplitude discriminate pulses as inputs to the maximum pulse width and total count circuits.

The static threshold bias calibrations as a function of threshold command number are given in Table #11 and the dynamic characteristics in Tables #12 and 13. The threshold bias ladder voltage (TS_{TM}) to identify the Command Number is also given in Table #11.

8.5 Dead Time Calibration

The Dead Time is that interval after the trailing edge of the first input pulse to exceed either positive or negative threshold bias at the voltage comparators. This gated interval is used to inhibit the voltage comparators for its duration.

The Dead Time calibrations and associated Command Ladder voltage for telemetry are given in Table #14. The scale factor for these Dead Times can be altered by changing capacitor C2 in Schematic D-2083. And the dynamic range can be altered by changing the timing resistors R3 through R10.

9.0 FUTURE PROGRAM

The Pulse Monitor System designed and developed under this contract is essentially a black box having a two terminal input and 12 analog outputs. These 12 outputs characterize bandwidth by measuring Totals and/or Maximum characteristics of the input pulses during a relatively long and fixed sample interval.

The object is to obtain a first crack at the sensing and measurement of various phenomena in space that are known to exist. And although the PMS is designed to simplify the measurements by threshold limits and inhibit gates after large initial pulses - it can - by elaborate calibration of its input - output transfer characteristics plus empirical experience with reproducible discharges in the laboratory with various antennae or probe geometrics - possibly provide a quantitative measurement of these phenomena. Even the absence of measurements for a particular pulse characteristic for a system whose specifications are well known is significant.

9.1 Electrical Calibration

The input - output calibrations for the PMS done with mostly unipolar or constant amplitude, or constant width, or constant rate pulse trains. It would be interesting and

desirable to measure the polarity discrimination, maximum pulse width, maximum pulse amplitude, total energy, and total count using a synchronous pulse trains of different polarities, and/or different amplitudes, and/or widths, at different frequencies, etc. The saturation, limiting and blocking characteristics of the electronics should be studied. The use of pulse bursts in conjunction with the different programmable dead times should be observed.

9.2 Laboratory Discharge Sources

It would be desirable to have a number of laboratory discharge sources to empirically exercise the PMS. Ideally these sources should be different in character, but, as constant as possible for successive discharges in order to be able to repeat measurements for different operating modes of the PMS. It is known that the Project Scientist has already developed a number of discharge systems capable of operating in different modes over a wide dynamic range of energy levels and plans are underway to construct discharge sources using dielectric plates and charged particle guns to achieve breakdown levels in a vacuum. Use of these devices in future tests should provide a good chance to demonstrate how fortunate the dynamic range and scale factor choices were for the 5 measurement parameters of the PMS when tied in with the experiments of 9.3 below.

9.3 Probe Geometry

As a first cut for a PMS probe it was proposed to use an antenna having a length of about one meter and an area of 10 cm^2 . It would be a simple matter using the various discharge sources referred in 9.2 above to determine the transfer characteristic from different energy level sources to the probe for different orientations and distances. It is possible that a few different probe geometry designs could lead to an optimum design, hopefully still compatible with the size constraints imposed by satellite applications.

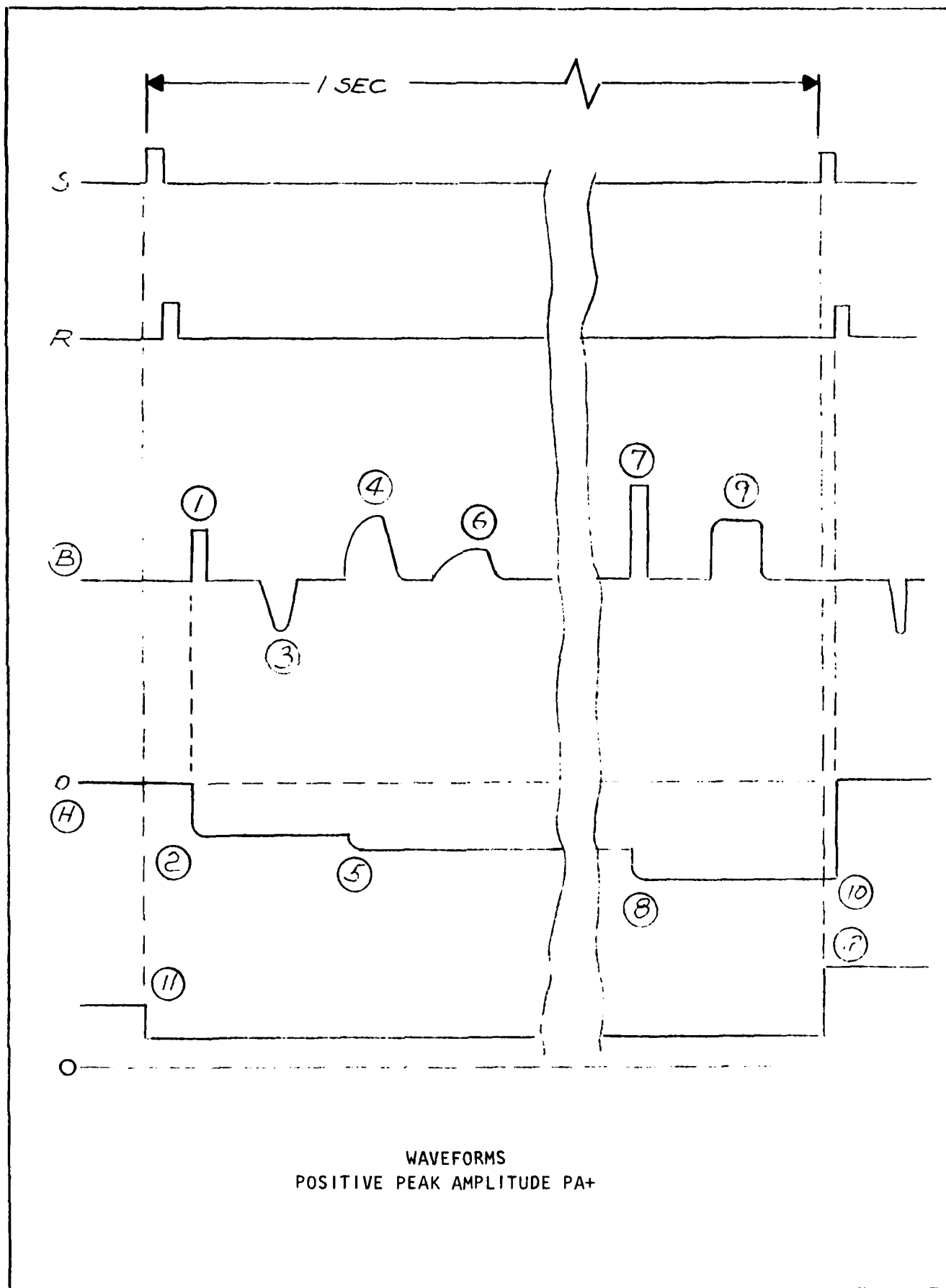

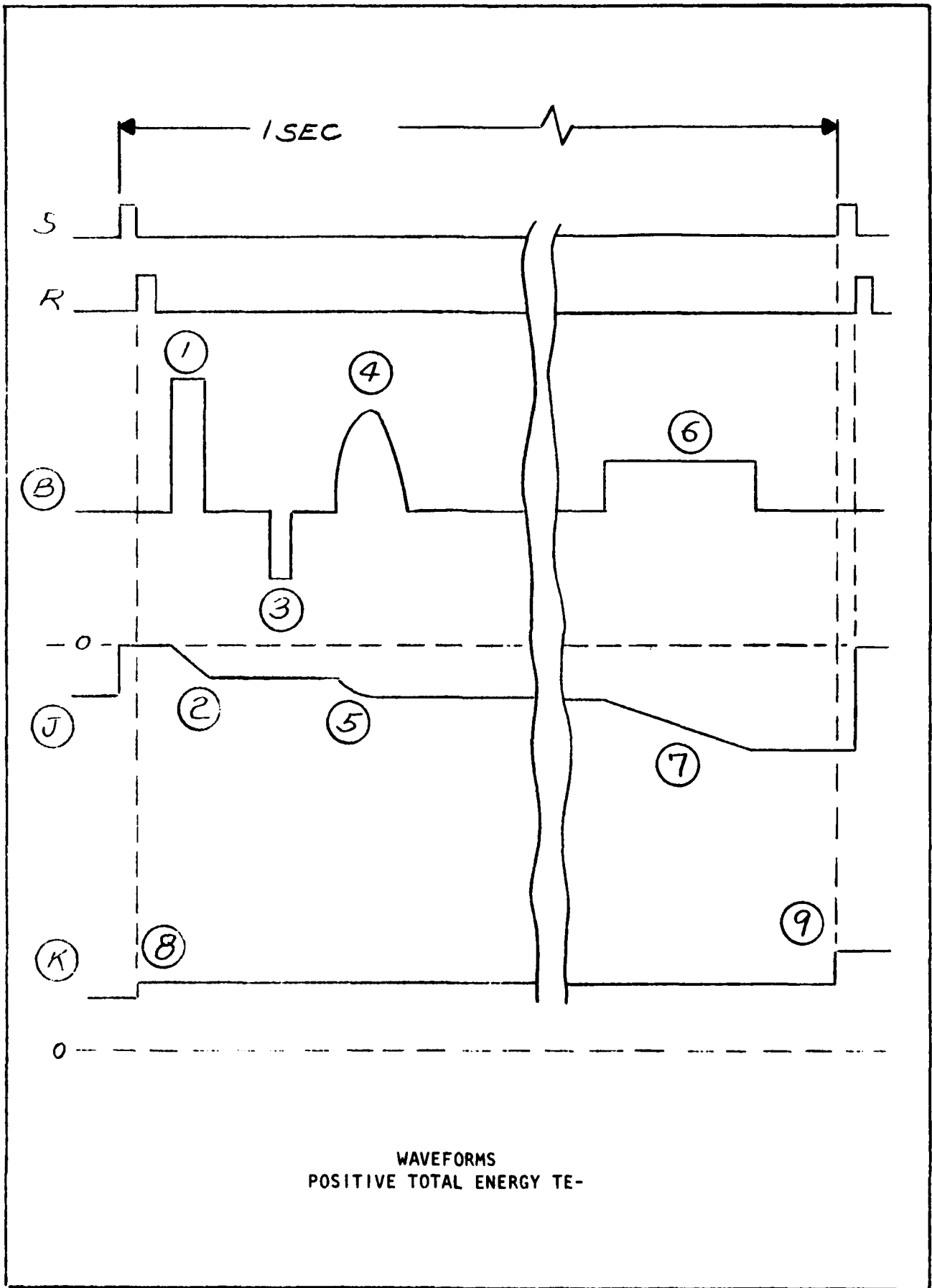

WAVEFORMS
 POSITIVE TOTAL ENERGY TE-

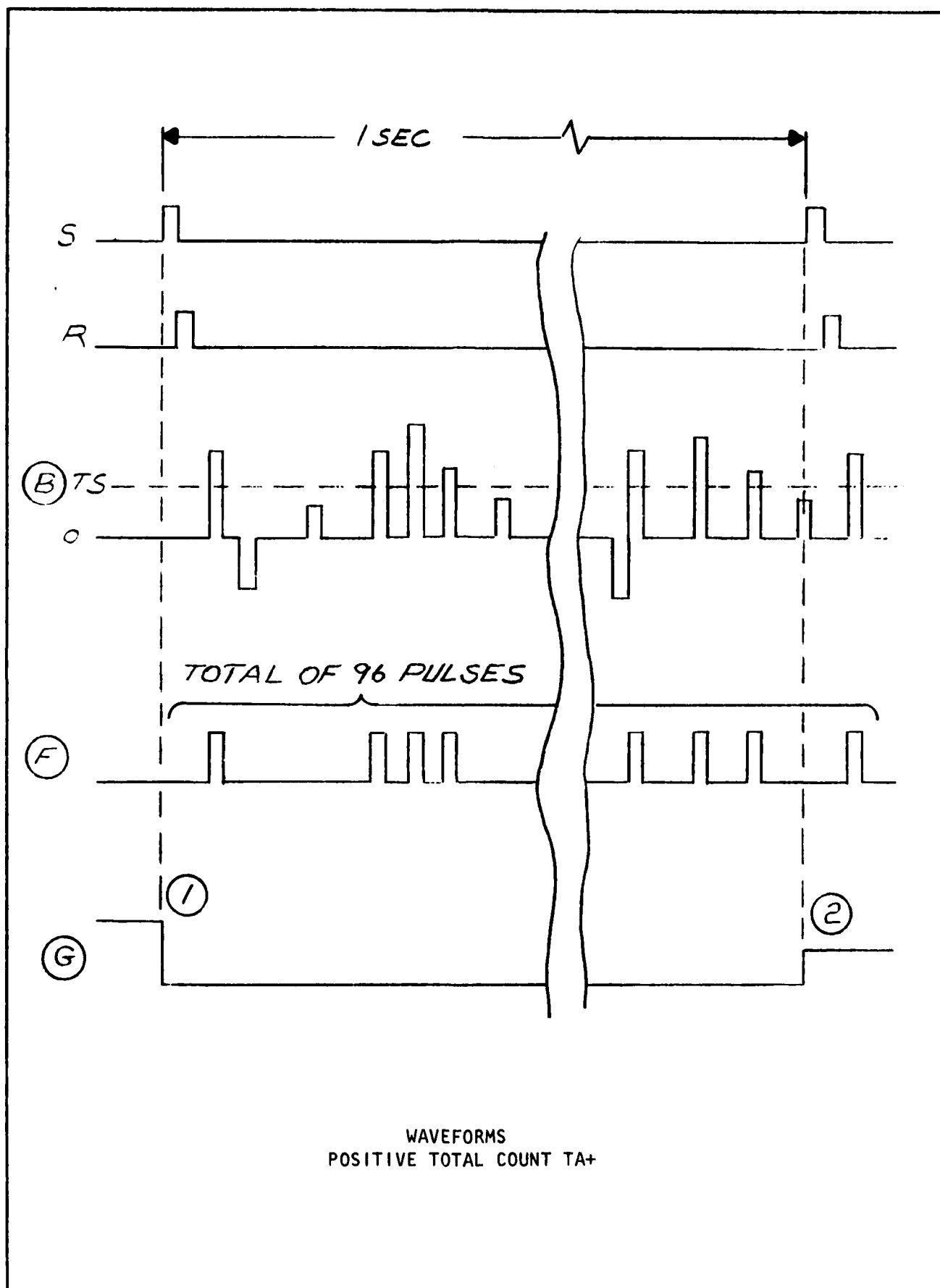

WAVEFORMS
 POSITIVE TOTAL COUNT TA+

FIGURE 3

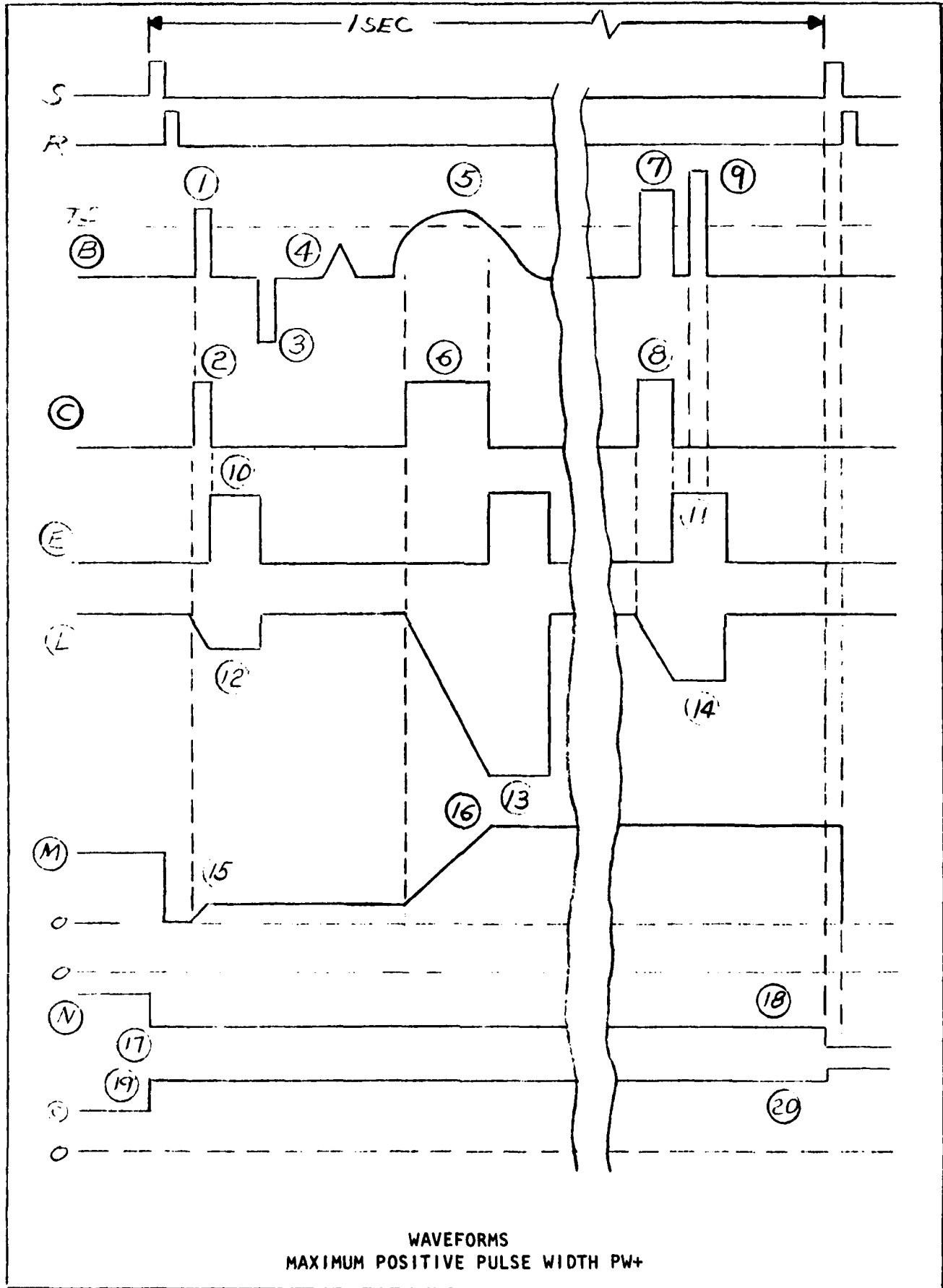

WAVEFORMS
 MAXIMUM POSITIVE PULSE WIDTH PW+

DIETZGEN CORPORATION
MADE IN U.S.A.

NO. 340-LS10 DIETZGEN GRAPH PAPER
SEMI-LOGARITHMIC
5 CYCLES X 10 DIVISIONS PER INCH

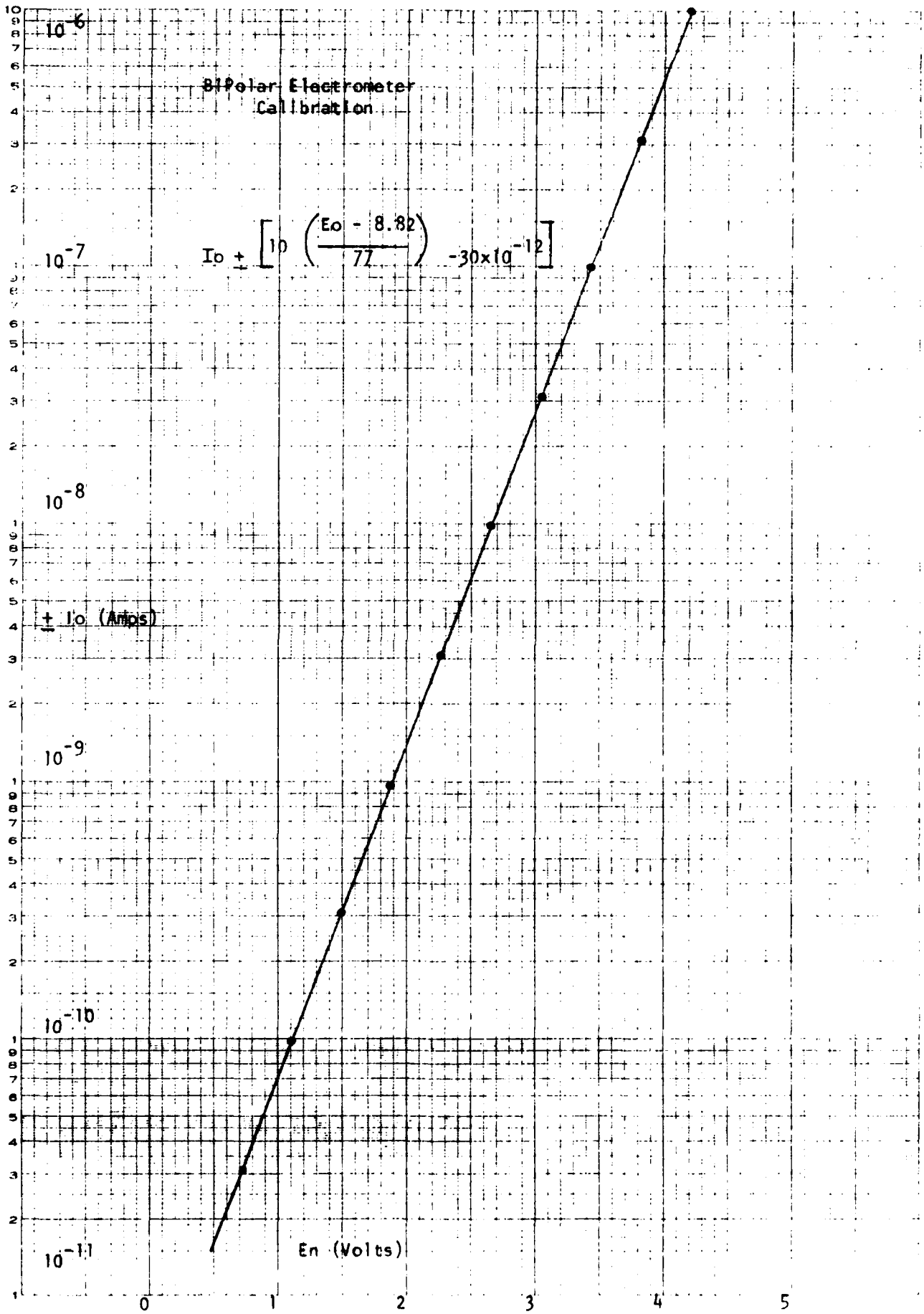

FIGURE 5

JR Inputs From Rocket

2DA31 P

| | | | |
|----|---|------------------------|--------|
| 1 | | S GRD | |
| 2 | | +28 | |
| 3 | I | DT Command Bit 1 (o) | J4-P21 |
| 4 | J | DT Command Bit 1 (1) | J4-P22 |
| 5 | K | DT Command Bit 2 (o) | J4-P23 |
| 6 | L | DT Command Bit 2 (1) | J4-P24 |
| 7 | M | DT Command Bit 3 (o) | J4-P25 |
| 8 | N | DT Command Bit 3 (1) | J4-P26 |
| 9 | | | |
| 10 | | | |
| 11 | | | |
| 12 | | | |
| 13 | | | |
| 14 | | | |
| 15 | | +15 Volts | |
| 16 | | | |
| 17 | | -15 Volts | |
| 18 | | | |
| 19 | | TM GRD | |
| 20 | | | |
| 21 | A | Bias Command Bit 1 (o) | J4-P37 |
| 22 | B | Bias Command Bit 1 (1) | J4-P38 |
| 23 | C | Bias Command Bit 2 (o) | J4-P39 |
| 24 | D | Bias Command Bit 2 (1) | J4-P40 |
| 25 | E | Bias Command Bit 3 (o) | J4-P41 |
| 26 | F | Bias Command Bit 3 (1) | J4-P42 |
| 27 | G | Bias Command Bit 4 (o) | J4-P43 |
| 28 | H | Bias Command Bit 4 (1) | J4-P44 |
| 29 | | | |
| 30 | | | |
| 31 | | C GRD | |

TABLE 1

| JA | | Analog Outputs | |
|--------|-----|--------------------|--------|
| 2DE19S | | | |
| 1 | | S GRD | |
| 2 | | | |
| 3 | TS | Analog Bias | J4-P31 |
| 4 | DT | Analog Dead Time | J4-P32 |
| 5 | | | |
| 6 | | | |
| 7 | Eo+ | Electrometer (+I) | JPE-P7 |
| 8 | Eo- | Electrometer (-I) | JPE-P8 |
| 9 | TE+ | Total Energy (+) | J3-9 |
| 10 | TE- | Total Energy (-) | J3-10 |
| 11 | TA+ | Total Count (+) | J1-31 |
| 12 | TA- | Total Count (-) | J1-32 |
| 13 | | | |
| 14 | PA+ | Peak Amplitude (+) | J2-P14 |
| 15 | PA- | Peak Amplitude (-) | J2-P15 |
| 16 | PW+ | Peak Width (+) | J2-P16 |
| 17 | PW- | Peak Width (-) | J2-P17 |
| 18 | | C GRD | |
| 19 | | TM GRD | |

TABLE 2

JP Probe Electronics

DAM-11 WIP

| | | | |
|----|-----|-------------------|--------|
| 1 | | S GRD | |
| 2 | | TM GRD | |
| 3 | | C GRD | |
| 4 | | +15 | |
| 5 | | -15 | |
| 6 | | + 5 | |
| 7 | Eo+ | Electrometer (+I) | JPE-P7 |
| 8 | Eo- | Electrometer (-I) | JPE-P8 |
| 9 | | | |
| 10 | | | |
| C | PIN | Input Pulse | JPE-PC |

TABLE 3

Bipolar Electrometer Calibration

| $\pm I$ (Amps) | $E_o(+)$ (Volts) | $E_o(=)$ (Volts) |
|------------------------|------------------|------------------|
| 0 | .01 | .03 |
| 10^{-11} | .36 | .37 |
| 3.16×10^{-11} | .71 | .71 |
| 10^{-10} | 1.09 | 1.10 |
| 3.16×10^{-10} | 1.48 | 1.48 |
| 10^{-9} | 1.86 | 1.87 |
| 3.16×10^{-9} | 2.26 | 2.25 |
| 10^{-8} | 2.64 | 2.64 |
| 3.16×10^{-8} | 3.03 | 3.02 |
| 10^{-7} | 3.42 | 3.41 |
| 3.16×10^{-7} | 3.81 | 3.79 |
| 10^{-6} | 4.19 | 4.17 |
| 3.16×10^{-6} | 4.56 | 4.54 |
| 10^{-5} | 4.68 | 4.73 |
| 3.16×10^{-5} | 4.97 | 5.00 |

TABLE 4

Total Energy (+) TE+ Calibration

Conditions

Pulse Width $t = 10 \text{ us}$
 Pulse Amp $V_i = 2.0 \text{ V}$
 Sample Time $ST = 1.08 \text{ sec.}$

| Pulse Interval $\Delta T(\text{ms})$ | Duty Cycle | TE+ Volts |
|---|----------------------|-----------|
| 10 | 1×10^{-3} | 5.3 |
| 20 | $.5 \times 10^{-3}$ | 4.9 |
| 25 | $.4 \times 10^{-3}$ | 4.1 |
| 33 | $.3 \times 10^{-3}$ | 3.0 |
| 66 | $.15 \times 10^{-3}$ | 1.6 |
| 100 | $.1 \times 10^{-3}$ | 1.05 |
| 250 | $.04 \times 10^{-3}$ | 0.4 |

TABLE 5

Total Energy(-) TE(-) Calibration

Conditions

Pulse Width $t = 10 \text{ us}$
 Pulse Amp $V_i = 2.0 \text{ V}$
 Sample Time $ST = 1.08 \text{ sec.}$

| Pulse Interval $\Delta T(\text{ms})$ | Duty Cycle | TE- Volts |
|---|-----------------------|--------------|
| 250 | $.04 \times 10^{-3}$ | .25 |
| 200 | $.05 \times 10^{-3}$ | .45 |
| 100 | $.1 \times 10^{-3}$ | .9 |
| 50 | $.2 \times 10^{-3}$ | 1.9 |
| 40 | $.25 \times 10^{-3}$ | 2.2 |
| 35 | $.29 \times 10^{-3}$ | 2.6 |
| 30 | $.33 \times 10^{-3}$ | 3.0 |
| 20 | $.5 \times 10^{-3}$ | 4.6 |
| 16 | $.625 \times 10^{-3}$ | 5.1 |
| 10 | 1.0×10^{-3} | 5.3 |

TABLE 6

Total Energy (+) TE+ Calibration

Conditions

Pulse Width $t = 1 \text{ us}$
 Pulse Amp $V_i = 2.0 \text{ v}$
 Sample Time $ST = 1.08 \text{ sec.}$

| Pulse Interval $\Delta T(\text{ms})$ | Duty Cycle | TE+ Volts |
|---|-----------------------|-----------|
| 0.5 | 2×10^{-3} | 5.3 |
| 1.0 | 1×10^{-3} | 4.0 |
| 1.2 | $.83 \times 10^{-3}$ | 3.3 |
| 1.6 | $.625 \times 10^{-3}$ | 2.55 |
| 2.5 | $.4 \times 10^{-3}$ | 1.6 |
| 3.0 | $.33 \times 10^{-3}$ | 1.35 |
| 5.0 | $.2 \times 10^{-3}$ | 0.78 |
| 10.0 | $.1 \times 10^{-3}$ | 0.4 |

TABLE 7

Total Energy(+) TE+ Calibration

Conditions

Pulse Width $t = 50 \text{ us}$
 Pulse Amp $V_i = 2.0 \text{ V}$
 Sample Time $ST = 1.08 \text{ sec.}$

| Pulse Interval $\Delta T(\text{ms})$ | Duty Cycle | TE+ Volts |
|---|-----------------------|-----------|
| 80 | $.625 \times 10^{-3}$ | 5.32 |
| 100 | $.5 \times 10^{-3}$ | 4.9 |
| 150 | $.33 \times 10^{-3}$ | 3.5 |
| 250 | $.2 \times 10^{-3}$ | 2.0 |
| 500 | $.1 \times 10^{-3}$ | 1.0 |

TABLE 8

Peak Amplitude (-), PA-, Calibration

Conditions

Pulse Width, $t = 1 \mu s$
 Pulse Interval, $\Delta T = 5 \text{ ms}$
 Sample Time, $ST = 1.08 \text{ seconds}$

| Pulse Amp V_i (volts) | PA- Volts |
|-------------------------------|--------------|
| 0 | 0.24 |
| 0.4 | 0.70 |
| 0.5 | 0.92 |
| 0.75 | 1.50 |
| 1.0 | 2.0 |
| 1.5 | 3.0 |
| 2.0 | 3.8 |
| 3.0 | 5.3 |

Peak Amplitude (-), PA-, Calibration

Conditions

Pulse Amplitude, $V_i = 2.0 \text{ v}$
 Pulse Interval, $\Delta T = 5 \text{ ms}$
 Sample Time, $ST = 1.08 \text{ seconds}$

| Pulse Width T (μs) | PA- Volts |
|-----------------------------------|--------------|
| 5 | 3.7 |
| 10 | 3.7 |
| 20 | 3.8 |
| 200 | 3.9 |
| 2000 | 3.9 |

TABLE 9

Maximum Pulse Width (+) PW+ Calibration

Conditions

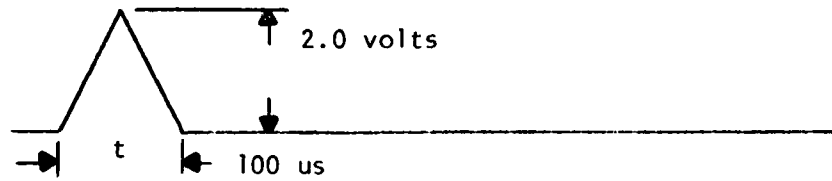

Pulse Width, $t = 100 \text{ us}$
 Pulse Interval $\Delta T = 100 \text{ ms}$
 Sample Time, $ST = 1.08 \text{ sec.}$

| Switch Bias Position | Bias Voltage | PW + Volts |
|----------------------|--------------|------------|
| - | - | - |
| - | - | - |
| 4 | +0.47 | 5.3 |
| 5 | +0.58 | 5.2 |
| 6 | +0.75 | 4.8 |
| 7 | +0.92 | 4.1 |
| 8 | +1.16 | 3.1 |
| 9 | +1.44 | 1.8 |
| 10 | +1.84 | 0.15 |
| 11 | +2.27 | 0.1 |

TABLE 10

Threshold Bias Calibration

| GSE Command | Bias | | TS TM Volts |
|----------------|-----------|-----------|-------------------|
| | (-) Volts | (+) Volts | |
| 0 | -0.24 | +0.19 | 5.5 |
| 1 | -0.29 | +0.24 | 5.2 |
| 2 | -0.36 | +0.31 | 4.7 |
| 3 | -0.43 | +0.39 | 4.4 |
| 4 | -0.53 | +0.47 | 4.0 |
| 5 | -0.64 | +0.58 | 3.6 |
| 6 | -0.81 | +0.75 | 3.2 |
| 7 | -0.99 | +0.92 | 2.9 |
| 8 | -1.24 | +1.16 | 2.5 |
| 9 | -1.52 | +1.44 | 2.2 |
| 10 | -1.93 | +1.84 | 1.8 |
| 11 | -2.37 | +2.27 | 1.5 |
| 12 | -2.84 | +2.73 | 1.1 |
| 13 | -3.49 | +3.37 | .7 |
| 14 | -4.44 | +4.29 | .4 |
| 15 | -5.47 | +5.30 | 0 |

TABLE 11

Dynamic Threshold Bias Calibration

Conditions

Pulse Width $t = 4 \mu\text{s}$

Pulse Interval $\Delta T = 1 \text{ ms}$

Sample Time $ST = 1.08 \text{ seconds}$

Detection is Pulse Amp V_i at Which Max Pulse Width (-), PW-,
Reads 1.0 Volts

| Bias Switch Position | Bias -Volts | Threshold Amp V_i (Volts) |
|----------------------------|----------------|-----------------------------------|
| 0 | -.24 | .2 |
| 1 | .29 | .3 |
| 2 | .36 | .36 |
| 3 | .43 | .4 |
| 4 | .53 | .44 |
| 5 | .64 | .56 |
| 6 | .81 | .8 |
| 7 | .99 | .96 |
| 8 | 1.24 | 1.2 |
| 9 | 1.52 | 1.5 |
| 10 | 1.93 | 1.8 |
| 11 | 2.37 | 2.3 |
| 12 | 2.84 | 2.6 |
| 13 | 3.49 | 3.2 |
| 14 | 4.44 | 4.2 |
| 15 | 5.47 | 6.4 |

TABLE 12

Dynamic Threshold Bias Calibration

Conditions

Pulse Width $t = 4 \mu\text{s}$
 Pulse Interval $\Delta T = 1 \text{ ms}$
 Sample Time $ST = 1.08 \text{ seconds}$

Detection is Pulse Amp V_i at Which Max Pulse Width (+), PW+, Reads 1.4 Volts

| Bias Switch Position | Bias + Volts | Threshold Amplitude V_i (volts) |
|----------------------------|-----------------|---|
| 0 | + .19 | .24 |
| 1 | .24 | .30 |
| 2 | .31 | .36 |
| 3 | .39 | .44 |
| 4 | .47 | .52 |
| 5 | .58 | .64 |
| 6 | .75 | .80 |
| 7 | .92 | 1.02 |
| 8 | 1.16 | 1.64 |
| 9 | 1.44 | 1.60 |
| 10 | 1.84 | 2.0 |
| 11 | 2.27 | 2.4 |
| 12 | 2.73 | 2.9 |
| 13 | 3.37 | 3.6 |
| 14 | 4.29 | 4.6 |
| 15 | 5.30 | 6.0 |

TABLE 13

- Dead Time Calibration -

| GSE Command | Delay Time (μ s) | DT TM Volts |
|----------------|--------------------------|-------------------|
| 0 | 9.6 | 0 |
| 1 | 17.6 | 0.8 |
| 2 | 33.0 | 1.6 |
| 3 | 70.0 | 2.4 |
| 4 | 132 | 3.0 |
| 5 | 275 | 3.8 |
| 6 | 570 | 4.7 |
| 7 | 1100 | 5.4 |

TABLE 14

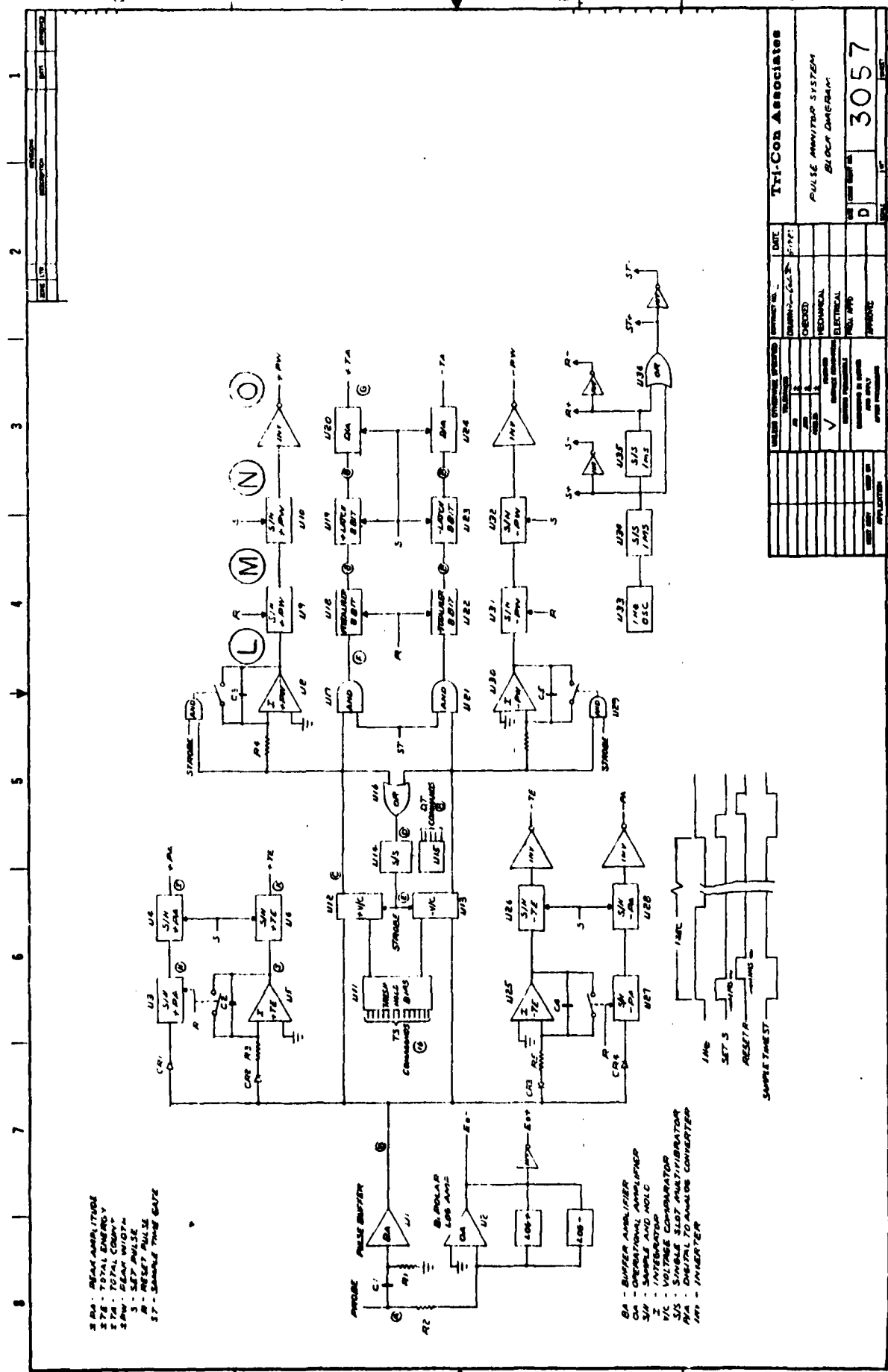

2PA - MEAS AMPLITUDE
 2TB - TOTAL ENERGY
 2TA - TOTAL COUNT
 2PW - PULSE WIDTH
 3 - SET PULSE
 M - RESET PULSE
 ST - SAMPLE TIME GATE

BA - BUFFER AMPLIFIER
 CA - OPERATIONAL AMPLIFIER
 SA - INTEGRATED HOLD
 VC - VOLTAGE COMPARATOR
 SJ5 - SAMPLE SLOT MULTIPLIER
 PA - DIGITAL TO ANALOG CONVERTER
 IN1 - INVERTER

| DATE | |
|-----------------|------|
| DESIGNED BY | DATE |
| CHECKED BY | DATE |
| MECHANICAL | DATE |
| ELECTRICAL | DATE |
| INSTRUMENTATION | DATE |
| TESTING | DATE |
| APPROVED BY | DATE |
| PROJECT NO. | 3057 |
| REV. | |
| DATE | |
| BY | |
| DESCRIPTION | |

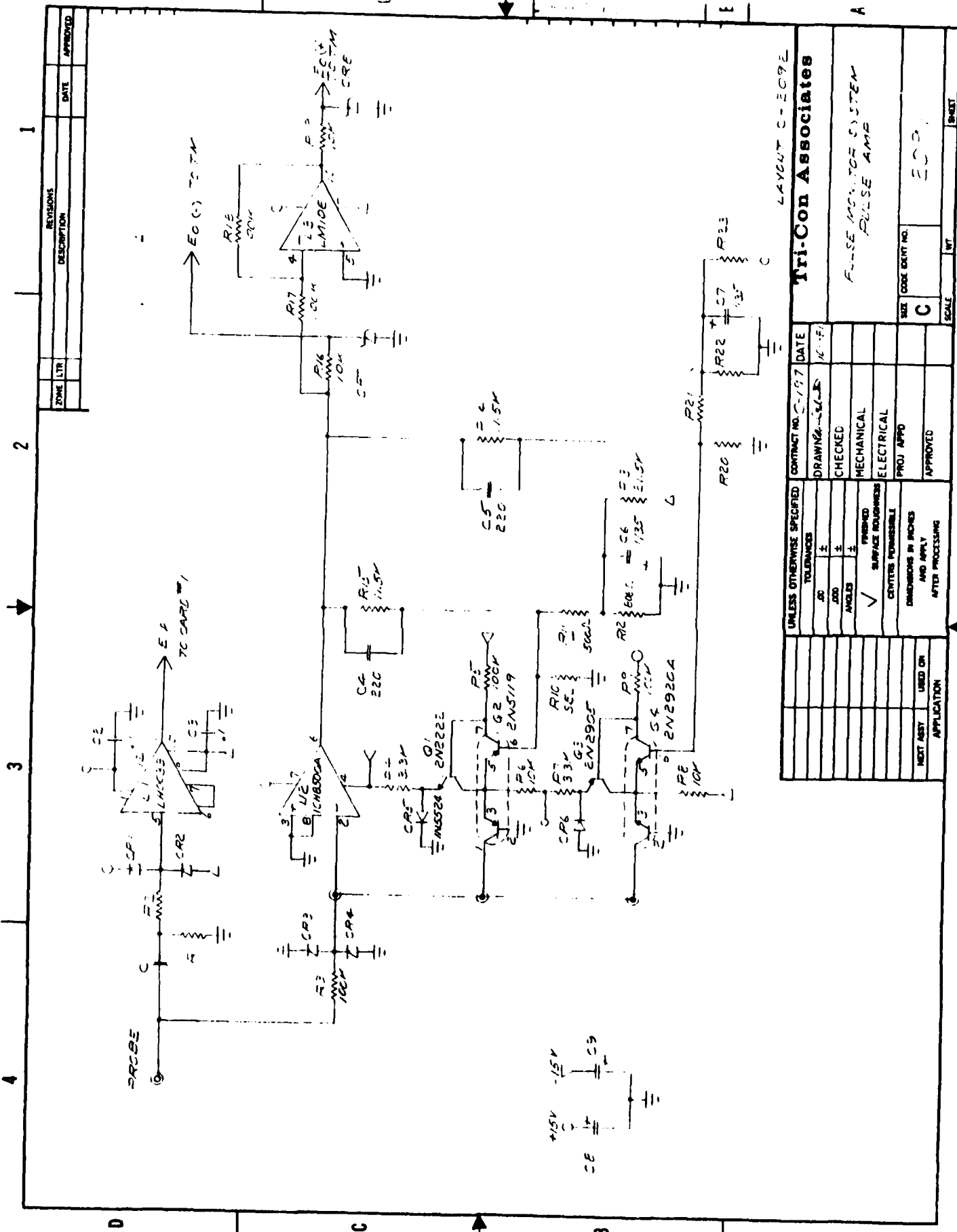

4 3 2 1

| REVISIONS | | DATE | APPROVED |
|-------------|-----|------|----------|
| ZONE | LTR | | |
| DESCRIPTION | | | |

LAYOUT C-2092

| UNLESS OTHERWISE SPECIFIED | | CONTRACT NO. C-197 | DATE |
|----------------------------|---|----------------------|---------------|
| TOLERANCES | | | |
| .00 | ± | | |
| .00 | ± | | |
| ANGLES | ± | | |
| ✓ | FRESHENED SURFACE FINISHES | CHECKED | |
| | CENTERS PERMISSIBLE | MECHANICAL | |
| | DIMENSIONS IN INCHES AND APPLY AFTER PROCESSING | ELECTRICAL | |
| | | PROJ. APPRO | |
| | | APPROVED | |
| APPLICATION | | SIZE | CODE DRGT NO. |
| | | C | 2001 |
| | | SCALE | 1/8" = 1" |
| | | NT | |
| | | Tri-Con Associates | |
| | | PULSE MONITOR SYSTEM | |
| | | PULSE AMP | |

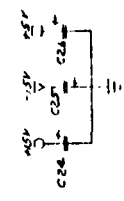
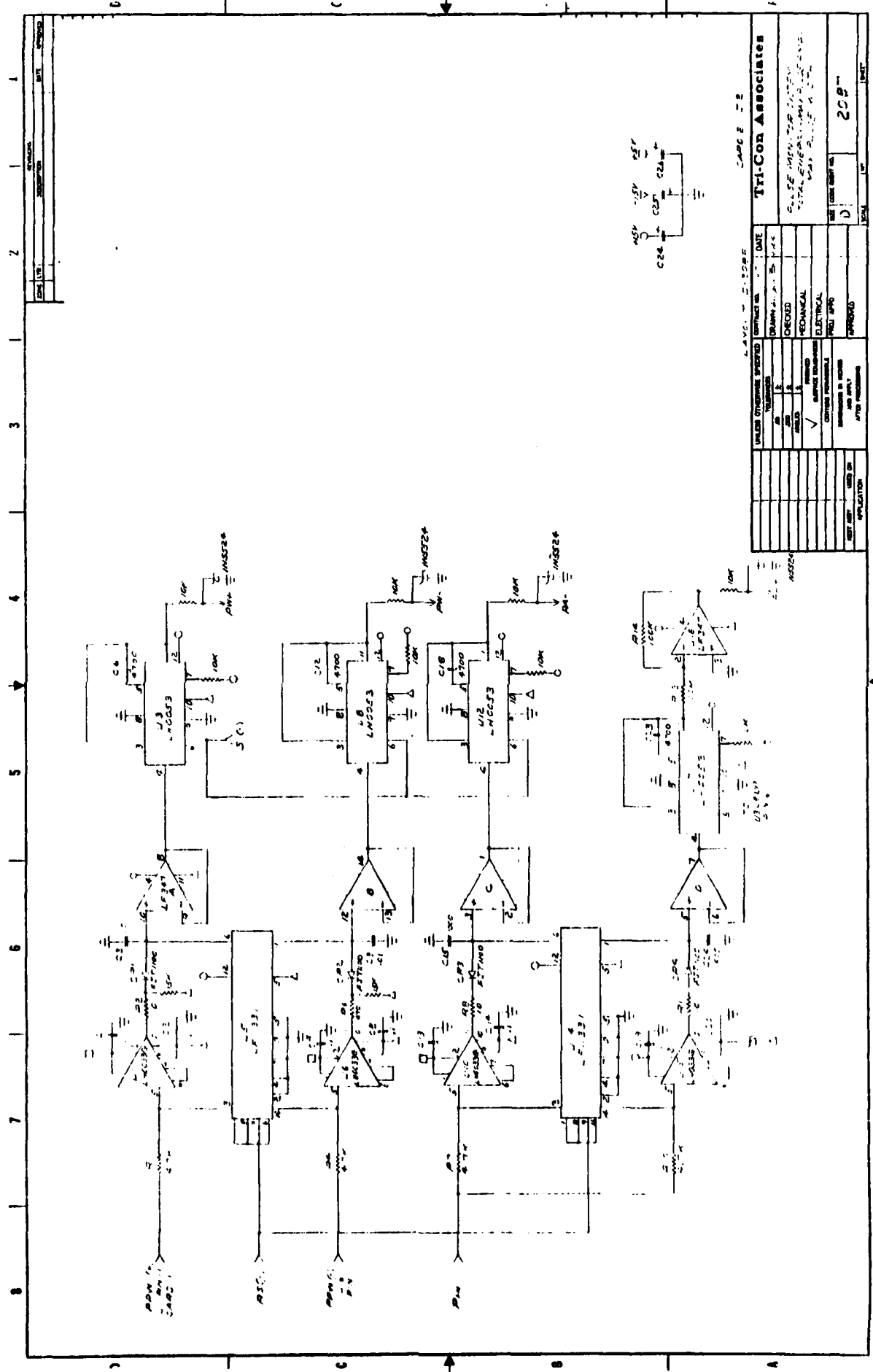

LAVEL - 5-2085 **CAPACITANCE** **TRICON ASSOCIATES**

| | |
|------------|------|
| DESIGNER | DATE |
| DRYER | 1/72 |
| DECKED | |
| MECHANICAL | |
| ELECTRICAL | |
| PROJ. NO. | |
| ISS. NO. | 208 |
| REV. NO. | |
| APPROVED | |

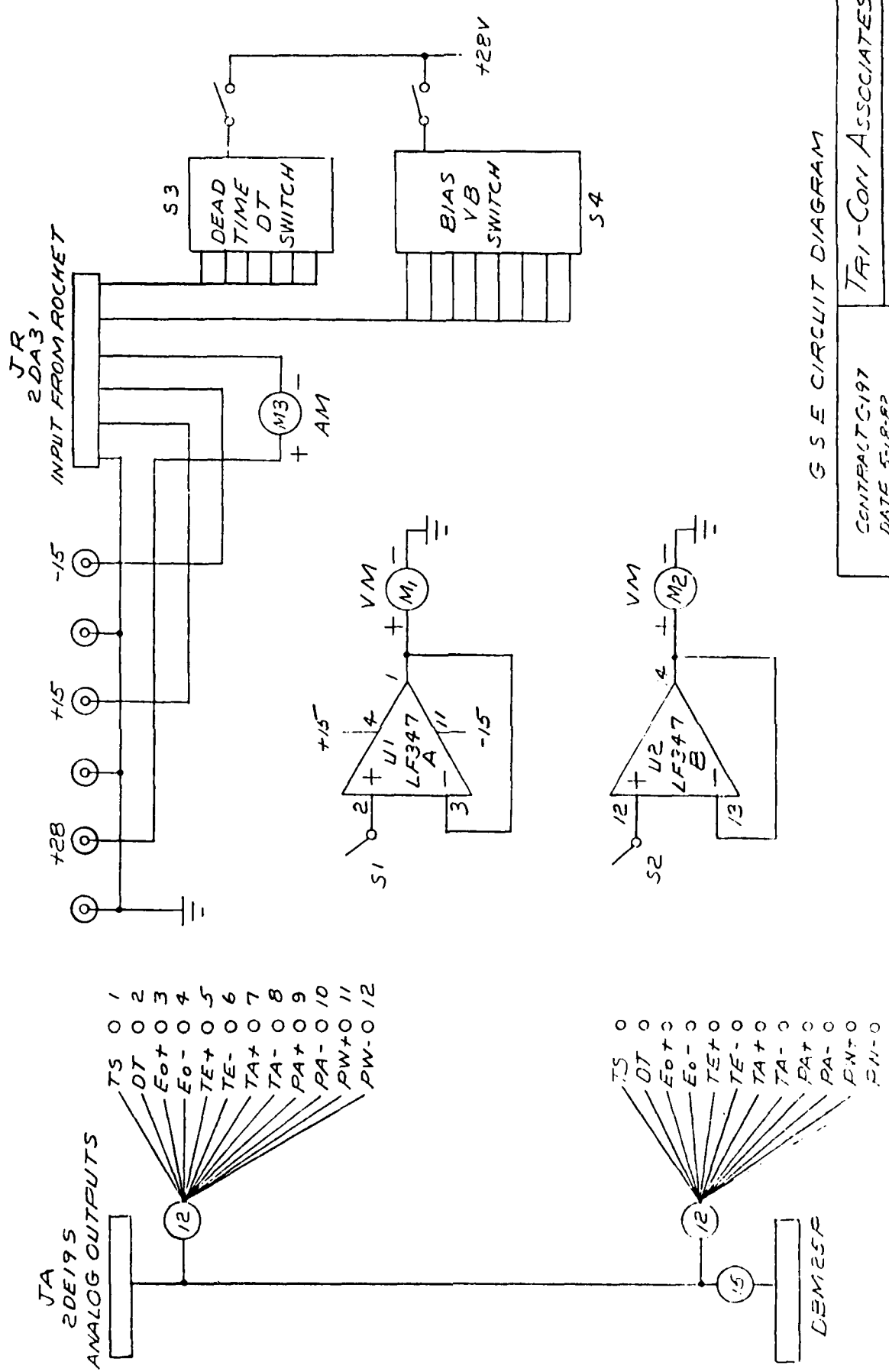

G S E CIRCUIT DIAGRAM

CONTRACT C-197
DATE 5-18-82

TRF1-CON ASSOCIATES

B-3033