

AD-A123 974

OCEANIC AREA SYSTEM IMPROVEMENT STUDY (OASIS) VOLUME II
NORTH ATLANTIC RE... (U) SRI INTERNATIONAL MENLO PARK CA
G J COULURIS SEP 81 OASIS-NAT-ATS FAA-EM-81-17-2
DOT-FA79WA-4265

1/2

UNCLASSIFIED

F/G 17/7

NL

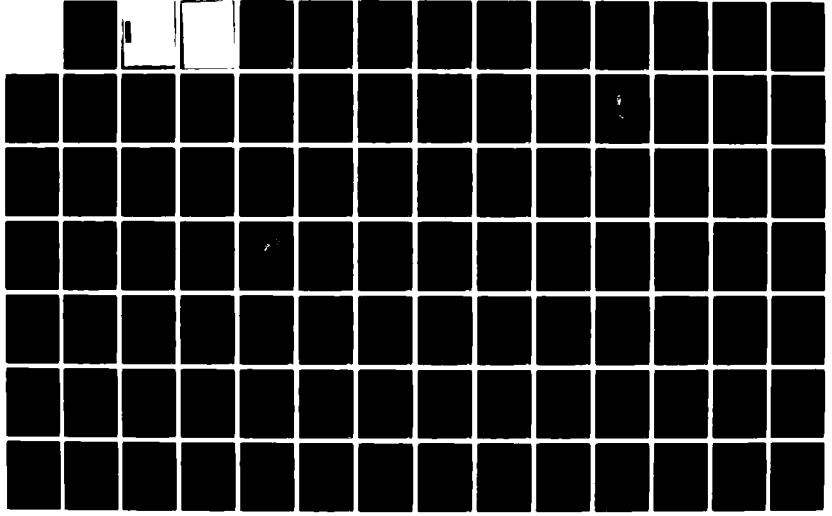

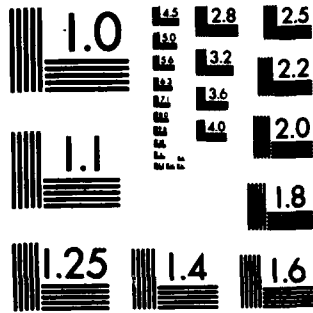

MICROCOPY RESOLUTION TEST CHART
NATIONAL BUREAU OF STANDARDS-1963-A

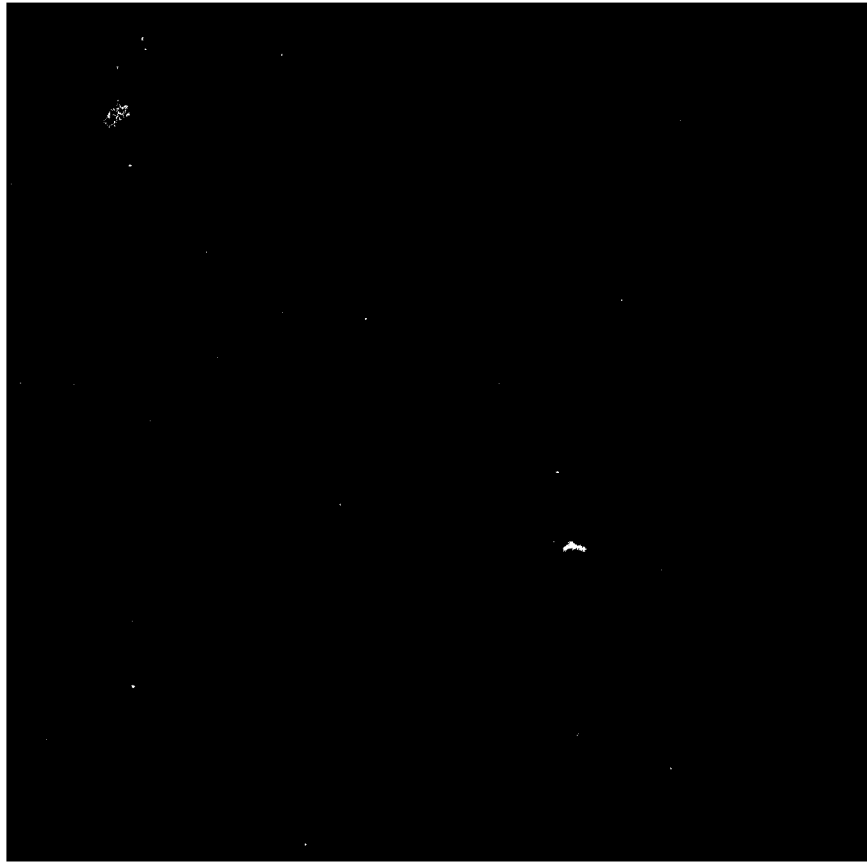

1. Report No. FAA-EM-81-17,II		2. Government Accession No. A123974		3. Recipient's Catalog No.	
4. Title and Subtitle OCEANIC AREA SYSTEM IMPROVEMENT STUDY (OASIS) VOLUME II NORTH ATLANTIC REGION AIR TRAFFIC SERVICES SYSTEM DESCRIPTION				5. Report Date September 1981	
				6. Performing Organization Code SRI Project 8066	
7. Author(s) G.J. Couluris				8. Performing Organization Report No. OASIS-NAT-ATS	
9. Performing Organization Name and Address SRI International 333 Ravenwood Ave Menlo Park, CA 94025				10. Work Unit No. (TRAIS)	
				11. Contract or Grant No. DOT-FA79WA-4265	
12. Sponsoring Agency Name and Address Department of Transportation Federal Aviation Administration Office of Systems Engineering Management Washington, D.C. 20591				13. Type of Report and Period Covered Final Report	
				14. Sponsoring Agency Code FAA-AEM	
15. Supplementary Notes					
16. Abstract <p>The Oceanic (and selected Non-Oceanic) Area System Improvement Study (OASIS), conducted by SRI International under contract with the Federal Aviation Administration (FAA), was part of a broad oceanic aeronautical system improvement study program coordinated by the "Committee to Review the Application of Satellite and Other Techniques to Civil Aviation" (also called the Aviation Review Committee or the ARC). The OASIS Project, with inputs from the international aviation community, examined current and potential future oceanic air traffic control (ATC) systems in the North Atlantic (NAT), Central East Pacific (CEP), and Caribbean (CAR) regions. This phase of the Aviation Review Committee program began in late-1978 and was completed in mid-1981.</p> <p>→ The thrust of the Aviation Review Committee program, which OASIS broadly supported, was to analyze the present ATC systems; examine future system requirements; identify areas where the present systems might be improved; and develop and analyze potential system improvement options. The time frame of this study is the period 1979 to 2005.</p> <p>> This report describes the present air traffic services (ATS) system in the NAT region. This system provides ATC, flight information, and alerting services to aircraft in oceanic control areas (CTAs)/flight information regions (FIRs). The report addresses the operations, technical components, and costs of the following ATS units: Gander Area Control Center (ACC); Shanwick Oceanic Area Control Center (OACC); New York ACC; Santa Maria ACC; Reykjavik ACC; San Juan ACC, and Miami ACC.</p>					
17. Key Words North Atlantic (NAT), Air Traffic Services (ATS), Oceanic Air Traffic Control (ATC)			18. Distribution Statement Document is available to the U.S. public through the National Technical Information Service, Springfield, Virginia 22161		
19. Security Classif. (of this report) Unclassified		20. Security Classif. (of this page) Unclassified		21. No. of Pages	22. Price

Oceanic Area System Improvement Study (OASIS)

Final Report

This report is one of a set of companion documents which includes the following volumes:

Volume I

Executive Summary and Improvement Alternatives Development and Analysis

Volume II

North Atlantic Region Air Traffic Services System Description

Volume III

Central East Pacific Region Air Traffic Services System Description

Volume IV

Caribbean Region Air Traffic Services System Description

Volume V

**North Atlantic, Central East Pacific, and Caribbean Regions
Communication Systems Description**

Volume VI

**North Atlantic, Central East Pacific, and Caribbean Regions
Navigation Systems Description**

Volume VII

North Atlantic Region Flight Cost Model Results

Volume VIII

Central East Pacific Region Flight Cost Model Results

Volume IX

Flight Cost Model Description

Volume X

**North Atlantic, Central East Pacific, and Caribbean Regions
Aviation Traffic Forecasts**

PREFACE

The Oceanic Area System Improvement Study (OASIS) was conducted in coordination with the "Committee to Review the Applications of Satellite and Other Techniques to Civil Aviation." This study examined the operational, technological, and economic aspects of the current and proposed future oceanic air traffic systems in the North Atlantic (NAT), Caribbean (CAR), and Central East Pacific (CEP) regions and assessed the relative merits of improvement options. A key requirement of this study was to develop a detailed description of the present air traffic system. In support of this requirement, and in cooperation with working groups of the Committee, questionnaires were distributed to the providers and users of the oceanic air traffic systems. Responses to these questionnaires, special reports prepared by system provider organizations, other publications, and field observations made by the OASIS staff were the basis for the systems descriptions presented in this report. The descriptions also were based on information obtained during Working Group A and B meetings and workshops sponsored by Working Group A. The information given in this report documents the state of the oceanic air traffic system in mid 1979.

In the course of the work valuable contributions, advice, data, and opinions were received from a number of sources both in the United States and outside it. Valuable information and guidance were received and utilized from the International Civil Aviation Organization (ICAO), North Atlantic Systems Planning Group (NAT/SPG), the North Atlantic Traffic Forecast Group (NAT/TFG), several administrations, the International Air Transport Association (IATA), the airlines, the International Federation of Airline Pilots Association (IFALPA), other aviation associated organizations, and especially from the Committee to Review the Applications of Satellites and Other Techniques to Civil Aviation.

It is understood of course, and should be noted, that participation in this work or contribution to it does not imply either endorsement or agreement to the findings by any contributors or policy agreement by any administration which graciously chose to contribute.

Accession For	
NTIS GRA&I	<input checked="" type="checkbox"/>
DTIC TAB	<input type="checkbox"/>
Unannounced	<input type="checkbox"/>
Justification	
By _____	
Distribution/	
Availability Codes	
Dist	Avail and/or Special
A	



TABLE OF CONTENTS

PREFACE i

TABLE OF CONTENTS 111

LIST OF ILLUSTRATIONS vii

LIST OF TABLES ix

EXECUTIVE SUMMARY xi

ACKNOWLEDGEMENTS xv

ACRONYMS AND ABBREVIATIONS xvii

1.0 INTRODUCTION 1

 1.1 General 1

 1.2 Scope and Objective 1

 1.3 Contents of This Report 1

 1.4 ATS Requirements 2

2.0 ATS OVERVIEW--NAT OPERATING ENVIRONMENT 7

 2.1 Background 7

 2.2 Air Traffic Flow Patterns 7

 2.3 Airspace Organization and ATS Facilities 10

 2.4 Technical Systems Overview 13

 2.5 Oceanic Route Structures 14

 2.6 ATS Operating Procedures 19

3.0 ATS TECHNICAL STRUCTURE 25

 3.1 Introduction 25

 3.2 Communications Systems 25

 3.3 Navigation Systems 29

 3.4 Surveillance Systems 30

4.0 SEPARATION MINIMA 33

 4.1 Separation Minima Determination 33

 4.2 NAT Separation Standards Documentation 34

 4.3 Vertical Separation 34

 4.4 Lateral Separation 34

 4.5 Longitudinal Separation 35

 4.6 Composite Separation 36

 4.7 Minimum Navigation Performance Specifications 37

TABLE OF CONTENTS (Continued)

5.0 ORGANIZED TRACK SYSTEM	41
5.1 Historical Perspective	41
5.2 OTS Establishment Guidelines	41
5.3 OTS Establishment Procedures	43
5.4 OTS Establishment Practices	44
6.0 OPERATING PROCEDURES	53
6.1 Flight Planning	53
6.2 Domestic Airspace Operations	54
6.3 Oceanic Entry Operations	55
6.4 Oceanic Airspace Operations	58
6.5 Oceanic Exit Operations	62
6.6 Supersonic Transport Operations	63
6.7 Low Level Oceanic Operations	63
6.8 Current Plans for Improvement	64
6.9 Supplemental Operational Information	64
7.0 ATS COSTS--PRELIMINARY ESTIMATES	65
APPENDIX A GANDER ACC--SUPPLEMENTAL DESCRIPTIVE DATA (Excerpts from a Draft by Transport Canada)	67
APPENDIX B SHANWICK OACC--SUPPLEMENTAL DESCRIPTIVE DATA (Excerpts from a Draft by the CAA, UK)	79
APPENDIX C NEW YORK ACC--SUPPLEMENTAL DESCRIPTIVE DATA	91
APPENDIX D SANTA MARIA ACC--SUPPLEMENTAL DESCRIPTIVE DATA (Excerpts from an ACO Letter Draft Report)	101
APPENDIX E REYKJAVIK ACC--SUPPLEMENTAL DESCRIPTIVE DATA (Excerpts from a Paper by DCA, Iceland)	105
APPENDIX F SONDRESTROM FIC--SUPPLEMENTARY DESCRIPTIVE DATA (Excerpts from a Report by DCA, Denmark)	111
APPENDIX G SAN JUAN ACC--SUPPLEMENTAL DESCRIPTIVE DATA	117
APPENDIX H MIAMI ACC--SUPPLEMENTAL DESCRIPTIVE DATA	121
APPENDIX I NAT REGION SEPARATION STANDARDS (Excerpts from ICAO Doc. 7030)	125

TABLE OF CONTENTS (Concluded)

APPENDIX J METEOROLOGICAL DATA AND METHODS USED IN GENERATING THE AVIATION DIGITAL FORECAST	139
APPENDIX K SELECTED OPERATIONAL SITUATIONS	139
APPENDIX L ATS ANNUAL COST CALCULATIONS	145
REFERENCES	151

LIST OF ILLUSTRATIONS

1	REPRESENTATIVE PEAK DAY NUMBER OF NAT FLIGHTS	8
2	NAT AIRSPACE	11
3	ATS TRACKS, NEW YORK CTA/FIR	15
4	NAT SST TRACKS	17
5	OTS EXAMPLE (WESTBOUND TRAFFIC FLOW)	18
6	AN ESTIMATE OF VHF COVERAGE OF THE NORTH ATLANTIC AT 30,000 FEET	27
7	APPROXIMATE RADAR COVERAGE AT FL300--NAT (Incomplete)	31
8	STANDARD AND COMPOSITE TRACK AND FLIGHT LEVEL SYSTEMS	38
9	NORTH ATLANTIC MNPS AREA	39
10	WESTBOUND NORTH-ABOUT OTS EXAMPLE	46
11	WESTBOUND GREAT-CIRCLE OTS EXAMPLE	47
12	WESTBOUND SOUTH-ABOUT OTS EXAMPLE	48
13	OTS COMPOSITE TRACK LIMITS	50
A-1	GANDER ACC OPERATIONS ROOM LAYOUT	68
B-1	SHANWICK OACC OPERATIONS ROOM LAYOUT	80
C-1	NEW YORK ACC AREA F AIRSPACE SCHEMATIC	92
C-2	NEW YORK ACC CONTROL ROOM	94
C-3	NEW YORK CTA/FIR EXPERIMENTAL ROUTES	100
D-1	SANTA MARIA AC AND COM SUPPORT	102
D-2	SANTA MARIA ACC CONTROL ROOM LAYOUT	102
E-1	REYKJAVIK ACC FLOOR PLAN	107
G-1	SAN JUAN ACC AIRSPACE	118
G-2	SAN JUAN ACC CONTROL ROOM	119
H-1	MIAMI ACC NAT AIRSPACE	122
H-2	MIAMI ACC CONTROL ROOM	123

LIST OF TABLES

1	NAT ATS ORGANIZATIONS AND FUNCTIONS	12
2	MAJOR COMMUNICATIONS STATIONS IN SUPPORT OF NAT OACC/ACCS	28
3	SUGGESTED DIVERSION AND DELAY OPTIONS TO RESOLVE POTENTIAL CONFLICTS BETWEEN OTS TRACK TRAFFIC	56
4	SUGGESTED DIVERSION AND DELAY OPTIONS TO RESOLVE POTENTIAL CONFLICTS BETWEEN NON-OTS TRACK TRAFFIC	59
5	NAT ATS 1979 ANNUAL COST ESTIMATES	66
E-1	ALLOCATION OF ATS STAFF AT REYKJAVIK AND KEFLAVIK ATS UNITS ACCORDING TO TRAFFIC CATEGORY	109
I-1	TABLE OF CRUISING LEVELS	131
K-1	SURVEY OF STEP-CLIMBS IN THE GANDER/SHANWICK CTA/FIRS, JULY 1978	140
K-2	TYPICAL FLIGHT CHARACTERISTICS, JULY 1979	142

EXECUTIVE SUMMARY

Air traffic services (ATS) provided to aircraft flying in designated areas of the North Atlantic (NAT) oceanic region include: (1) air traffic control (ATC), (2) flight information and (3) alerting services. The designated areas include control areas (CTAs), where all three services are provided, and flight information regions (FIRs), where only flight information and alerting services are provided. The ATS units providing services in strictly oceanic CTAs are oceanic area control centers (OACCs), while units serving oceanic and domestic CTAs are area control centers (ACCs). Flight information centers (FICs) provide the non-ATC services in FIRs unless the responsibility of providing such services is assigned to ATS units. The designated areas and ATS unit are established by international agreement under the auspices of the International Civil Aviation Authority (ICAO).

This report is a description of the present ATS system in the NAT and emphasizes the services provided by the following ATS units: the Gander ACC, Shanwick OACC, New York ACC, Santa Maria ACC, Reykjavik ACC, San Juan ACC (excluding Caribbean airspace), and Miami ACC (excluding Caribbean airspace).

Radar surveillance of NAT airspace is not conducted due to the lack of ground sites for antennae, and ATS personnel use pilot position reports to monitor oceanic flights. These voice reports are transmitted at least once per hour. Direct air-ground communications between oceanic aircraft and ATS personnel are generally not available. Instead, the ATS units are supported by communication (COM) stations which operate very high frequency (VHF) and long-range, high frequency (HF) radio facilities. These COM stations relay messages between pilots and ATS unit personnel. The stations, usually located separately from the ATS units, include the Gander, Shannon, New York, Santa Maria, Gufunes, and San Juan COM stations. The ATS units and COM stations, as well as airline, military, meteorological, and other aviation facilities, are connected by the aeronautical fixed telecommunications network (AFTN), which provides teletype service, and ATS direct speech circuits.

NAT flights are conducted on the organized track system (OTS), random tracks, or ATS routes. The OTS is a set of approximately parallel tracks roughly between Newfoundland and the British Isles, and largely located in the Shanwick and Gander CTA/FIRs. Random and OTS tracks are navigated by aircraft typically equipped with inertial navigation system (INS) or Omega and doppler devices. The ATS routes are based on land-based nondirectional beacon (NDB) or very high frequency omnidirectional range (VOR) and distance measuring equipment (DME) radionavigation aids.

Based on an analysis of data describing high altitude subsonic turbojet traffic on a representative peak day in July, 1979, approximately 350 flights use the OTS, 175 flights use the ATS routes, and 245 flights use random tracks. The ATS route and random track flights are distributed among a variety of trans-Atlantic patterns, while the OTS traffic is highly concentrated and occurs in two distinct flows: a daytime westbound surge and a nighttime eastbound surge.

The placement of the OTS is determined by the geographic location of flight origins and destinations and upper air circulation forecasts. The upper air, which includes the jet stream, moves from west to east in complex patterns. Eastbound aircraft prefer to be in the region of the most significant wind velocity in order to take advantage of the high intensity tail wind component. Westbound aircraft prefer to fly either north or south of the most significant winds (or in some cases, perpendicular to them) in order to avoid the severe head wind component. The OTS is constructed twice daily to accommodate separately the flight path preferences of the eastbound and westbound traffic surges which occur at different times. The OTS structure is not fixed but changes from day to day because the upper air circulation pattern varies. On those infrequent days when there are not significant wind patterns, the OTS structure follows a great circle path between the major North American and European airports.

By international agreement, each aircraft flying in the oceanic CTAs files a flight plan which is forwarded to each ATS unit along the route of flight, and is provided with separation service by each unit. The flight is based on an analysis of meteorological conditions and aircraft performance characteristics and describes the desired flight tracks, altitudes and speeds of the aircraft. If there are no potential violations of separation minima with other aircraft or violations of airspace reservations, the oceanic ATS unit issues a clearance to the aircraft for its desired flight path. In the event of a potential conflict, the ATS unit identifies and issues an oceanic flight path clearance that conforms to the aircraft separation requirements. An oceanic clearance is issued by the ATS unit while the aircraft is in direct voice radio contact with the unit (or an adjacent domestic ATS unit) and before the aircraft enters the oceanic airspace. After oceanic entry, the COM station relays pilot position reports, requests for altitude change (if any) and other messages, as well as responses from the ATS unit. The ATS unit follows the progress of each flight by manually recording each reported position on paper flight strips.

Each flight on an OTS track is issued a conflict free clearance at a fixed flight level for the full length of the track to landfall. This procedure of issuing a fixed flight level clearance along a track is applied on random tracks as well as on OTS tracks by the Gander ACC and Shanwick OACC, and also might be applied by the Santa Maria and Reykjavik ACCs. An alternative procedure permits the inclusion of altitude or time restrictions in the oceanic clearance to resolve a

potential downstream conflict situation. This alternative clearance strategy is practiced at the New York, San Juan and Miami ACCs and is applied only to ATS route and random track traffic. The New York and Santa Maria ACCs apply fixed flight level clearances to aircraft entering OTS tracks on those occasions when such tracks are in their CTA/FIRs.

A pilot may request an altitude change while in oceanic airspace when the aircraft burns off sufficient fuel to attain a more economical higher flight level. A step climb approval is granted by the ATS unit subject to the satisfaction of the separation minima.

Coordination between ATS units routinely is conducted by means of the ATS direct speech and AFTN circuits. The transfer of flight data for most aircraft moving between the Gander ACC and the Shanwick OACC normally is performed by a special data link, and voice or teletype coordination usually is not required between these two units. Other ATS units must coordinate with each other to pass flight data for aircraft crossing their boundaries.

ACKNOWLEDGMENTS

We are highly appreciative of the guidance and support provided by the "Committee to Review the Application of Satellite and Other Techniques to Civil Aviation." We wish to thank Mr. V. E. Foose, FAA Program Manager, Mr. N. Craddock and Mr. J. Loos of the FAA, and the personnel at the Shanwick Oceanic Area Control Center and the Gander, New York, Santa Maria, Reykjavik, San Juan and Miami Area Control Centers for their guidance and assistance in this system description effort. Special acknowledgment is given to the support provided by Working Group A of the Committee, including the Working Group's rapporteur, Mr. J. Ruden.

This research was conducted by SRI International under the leadership of Dr. George J. Coukuris with the support of Ms. Janet Tornow, Ms. Mina Chan and Ms. Marika E. Garskis. Mr. Robert Mancuso and Mr. Peter Loats contributed descriptive information. Ms. Geri Childs prepared this report. The project was conducted under the administrative supervision of Dr. Robert S. Ratner and Mr. Joel R. Norman.

ACRONYMS AND ABBREVIATIONS

ACC	Area control center
ADF	Automatic direction finding
ADIS	Automated Data Interchange System
AFTN	Aeronautical fixed telecommunications network
A/G	Air-ground
AIREP	Air report
ANP	Air navigation plan
ATC	Air traffic control
ATS	Air traffic services
CAA	Civil Aviation Authority
CERAP	Combined en route and radar approach
COM	Communications
CTA	Control Area
DCA	Directorate of Civil Aviation
DME	Distance measuring equipment
EDT	Estimated departure time
FAA	Federal Aviation Administration
FAR	Federal Aviation Regulations
FDP	Flight data processing
FIC	Flight information center
FIR	Flight information region
FL	Flight level
ft	Feet
GAATS	Gander Automated Air Traffic System
GMT	Greenwich Mean Time
GTS	Global Telecommunications System
HF	High frequency
hr	Hour
ICAO	International Civil Aviation Organization
IFR	Instrument flight rule
INS	Inertial navigation system
LORAN	Long range navigation
mbar	Millibar
MHz	Megahertz
min	Minute
MNPS	Minimum navigation performance specifications
MTT	Minimum time track
NAR	North American routes
NAT	North Atlantic
NAT/SPG	North Atlantic Systems Planning Group
NDB	Nondirectional beacon
NMC	National Meteorological Center
nmi	Nautical mile
nmi/hr	Nautical mile per hour

ACRONYMS AND ABBREVIATIONS (Concluded)

NWS	National Weather Service
OACC	Oceanic area control center
OTS	Organized track system
PTT	Post, telephone and telegraph
RNAV	Area navigation
SELCAL	Selective calling
SIGMET	Significant meteorological data
SSB	Single sideband
SSR	Secondary surveillance radar
SST	Supersonic transport
TMA	Terminal Control Area
UHF	Ultra high frequency
UIR	Upper flight information region
UK	United Kingdom
US	United States
UTA	Upper control ara
VHF	Very high frequency
VOR	Very high frequency omnidirectional range

1.0 INTRODUCTION

1.1 General

Various nations, as contracting States to the International Civil Aviation Organization (ICAO), provide air traffic services (ATS) within designated areas of international oceanic airspace. The areas are determined by regional air navigation agreements that are approved by the Council of ICAO, normally on the advice of Regional Air Navigation Meetings. Each contracting State designates the authority responsible, typically a government agency, for establishing and providing ATS in accordance with the ICAO standards and recommended practices. These services are provided and supported by a complex structure of inter-related operational and technical components. Generally, the operational components--operating rules, procedures, requirements and associated facilities--are considered to be part of the ATS system. The technical components--communication, navigation, surveillance, and meteorological factors, etc.--are often considered as separate systems. However, because operating rules and procedures are dependent on the technological performance of the equipment in use, any description of an ATS system also should address its technical components.

1.2 Scope and Objective

This report presents a description of the operational and technical components of the present international ATS system in the North Atlantic (NAT) oceanic region. The purpose of this description is twofold: (1) to provide further understanding of the requirements and capabilities of the present ATS system, and (2) to provide an information base for subsequent evaluations of the system. The subsequent evaluations will examine the efficiency of current operations, the potential capability of the ATS system to meet future requirements, and potential system improvements.

1.3 Contents of This Report

The information and data presented are based on observations made during on-site visits to various ATS facilities, consultations with ATS operations and support personnel, and reports and data obtained from ATS provider organizations including Transport Canada; the Civil Aviation Authority (CAA) of the United Kingdom (UK); the Directorate of Civil Aviation, Denmark; the Directorate of Civil Aviation, Iceland; the Director General of Civil Aviation and the Airports and Air Navigation Public Enterprise, Portugal; and the Federal Aviation Administration (FAA) in the United States. Reports provided by Transport Canada and the CAA, UK, were especially useful sources of information concerning NAT operations.

This report consists of eight sections, as well as a number of appendices that provide supplemental descriptive data. Section 2.0 is a general overview of the ATS system in the NAT, including air traffic flow patterns, airspace organization and ATS facilities, technical systems, oceanic route structures, and ATS operating procedures. Sections 3.0, 4.0, 5.0 and 6.0 provide more detailed descriptions of the ATS system. These sections respectively address: technical aspects of the communication, navigation, and surveillance systems; separation minima; the organized track system used in the NAT; and ATS operational procedures. Section 7.0 summarizes preliminary estimates of the costs required to provide ATS in the NAT.

In order to understand the operating framework in which ATS are provided, a familiarity with the institutional basis for the ATS system is useful. Therefore, the remainder of this section presents an overview of the ATS requirements and practices as defined by ICAO. Those readers who are familiar with ICAO procedures and terminology should proceed to Section 2 of this report.

1.4 ATS Requirements

International ATS responsibilities, operating practices and procedural rules are established in accordance with special provisions contained in ICAO publications, including the annexes to the Convention on International Civil Aviation. Annex 11 (ref. 1) pertains to the establishment of airspace units and services necessary to promote a safe, orderly and expeditious flow of air traffic. Annex 2 (ref. 2) defines the general rules relating to flight and maneuver of aircraft. ICAO Document 4444, Procedures for Air Navigation Services--Rules of the Air and Air Traffic Services (PANS-RAC) (ref. 3), is complementary to Annex 2 and 11. The purpose of Document 4444 is to specify in detail the actual procedures to be applied by ATS units in providing various services to aircraft. ICAO Document 7030, Regional Supplementary Procedures (ref. 4), complements Document 4444 by describing those rules developed to meet the needs of specific areas which are not covered in the worldwide provisions.

In addition to the documents describing ATS requirements, ICAO air navigation plans (ANP) specify the physical and operational facilities that are internationally required or planned in each region. The ANPs (ref. 5,6,7,8 and 9) list the pertinent regional air navigation facilities and services including the meteorological, search and rescue, and aeronautical information systems. Document 7030 is the procedural counterpart of the regional ANPs.

The following paragraphs summarize the ATS requirements and practices pertinent to the NAT as specified by the ICAO provisions and as agreed to by the provider and user authorities. Further details concerning formal rules and practices are provided in subsequent sections to this report.

1.4.1 ATS Responsibilities

The Annex 11 provisions define ATS as consisting of three functions, as follows:

- (1) Oceanic air traffic control (ATC) service, whose objectives are to provide separation between aircraft and to expedite and maintain an orderly flow of air traffic. ATC service in oceanic airspace is restricted to area control service (i.e., excludes approach control service and aerodrome control service).
- (2) Flight information service, whose objective is to provide advice and information useful for the safe and efficient conduct of flight.
- (3) Alerting service, whose objective is to identify an emergency event and then notify appropriate organizations regarding aircraft in potential need of search and rescue aid and assist such organizations as needed.

The services are provided by designated ATS units that are responsible for operations in each oceanic area. The NAT ATS units are described in Appendices A through H.

1.4.2 Designation of ATS Areas

Annex 11 does not state that all three ATS functions--ATC, flight information, and alerting--must be provided simultaneously in an area receiving ATS service, but specifies that an airspace area should be designated in relation to the particular services that are to be provided. Two airspace designators relevant to oceanic areas are:

- (1) Flight information region (FIR), where flight information and alerting service are provided.
- (2) Control area (CTA), where ATC service is provided.

An FIR is delineated to cover the entire air route structure to be served by the region, and includes all airspace from the surface upward within its lateral limits, except as limited by an upper flight information region (UIR).

A CTA is delineated so as to contain the flight paths of those instrument flight rule (IFR) flights that are to receive ATC service, taking into account the capabilities of the navigation aids normally used in the vicinity. Although Annex 11 specifies that the lower limit of a CTA should be established at a height above the surface of not less than 70 feet (ft), the lower limit of oceanic CTAs in the NAT are

higher, such as at flight level (FL) 55 (i.e., at an atmospheric pressure altitude of 5500 ft). An upper limit is established if ATC service is not provided above this limit, or if the CTA is situated below an upper control area (UTA).

1.4.3 Designation of ATS Units

Annex 11 identifies two general types of ATS units:

- (1) ATC units
- (2) Flight information center (FIC).

ATC units are established to provide full ATS--ATC service, flight information service, and alerting service--in designated airspace areas. Where a unit provides both flight information and ATC services, the provision of ATC service has precedence over the provision of flight information service. The units providing services in strictly oceanic CTAs are oceanic area control centers (OACCs), while units serving oceanic and domestic CTAs are area control centers (ACCs). Although control centers generally have responsibility for total ATS service, in practice they may delegate elements of the flight information service to other units, including non-ATS units. For example, the responsibility for transmitting meteorological data to aircraft in an oceanic area may be assigned to an aeronautical communications (COM) station supporting an ATC unit.

An FIC provides flight information and alerting service within FIRs, unless the responsibility of providing such services is assigned to an ATC unit. An FIC, as in the case of the OACC example above, may delegate certain elements of the flight information service to other units.

1.4.4 Aircraft Separation

ATC units provide separation services between aircraft in CTAs except where aircraft are required to provide their own separation as in the case of operations in airspace reservation areas. Separation service provided in the NAT oceanic CTAs is based on the application of nonradar procedures and requires at least one of the following forms of separation as defined by ICAO Annex 11:

Vertical separation, obtained by assigning different levels of flight satisfying minimum vertical spacing specification.

Horizontal separation, obtained by providing longitudinal or lateral intervals (time or distance) between aircraft satisfying minimum horizontal spacing specifications.

Composite separation, consisting of a combination of vertical and lateral separation forms using minima for each which may be lower than, but not less than half of, those used for each of the combined elements when applied individually.

The vertical, horizontal, and composite separation minima and methods of application are specified for the NAT airspace area in Document 4444, PANS-RAC (ref. 3) and Document 7030, Regional Supplementary Procedures (ref. 4), parts of which are presented in Appendix I.

1.4.5 Additional ATS Requirements

Annex 11 stipulates requirements for providing communications services (i.e., aeronautical mobile and fixed) and information services (i.e., meteorological and navigational aids operating status data). These services are addressed in subsequent sections and in the appendices.

1.5 ATS Operating Practices

Annex 2 describes the required and recommended practices that are routinely carried out to fulfill the ATS responsibilities as performed by ATS providers and users. This annex requires users of ATS to file flight plans with ATS units and to update and terminate flight plans, and requires ATS units to check flight plans and provide users receiving ATC service with clearances (i.e., instructions and approvals) for the conduct of a flight. The flight plans describe the aircraft identities, equipment and planned speeds, routes, altitudes and times of flight, and related data. Annex 2 also identifies the practices for transmitting flight information--including position reports and air reports (AIREPs)--by pilots and the dissemination of pertinent aeronautical information by ATS units, including broadcasts of significant meteorological data (SIGMETs).

2.0 ATS OVERVIEW--NAT OPERATING ENVIRONMENT

2.1 Background

The development of the present ATS system began after World War II (ref. 10). It was designed to meet the air traffic needs of the aircraft in operation at that time subject to the constraints imposed by the navigation and communications technology available. Propeller and turboprop aircraft flying at altitudes up to FL270 and airspeeds up to 350 nautical miles (nmi)/hour (hr) were the prime users of the system. Navigation was performed by means of celestial, doppler, dead reckoning, radio direction finding, and, more extensively, Long Range Navigation (LORAN) facilities. LORAN is a method of navigation that depends on pulsed radio signals transmitted from ground stations. Communications systems consisted of telegraphy and high frequency (HF) air-ground radiotelephony.

Advancements in aircraft technology have significantly affected the system. Subsonic turbojet aircraft, introduced in the late 1950s, are now the primary users of the NAT ATS system. The subsonic jets cruise at higher altitudes, FL270 to FL450, and at higher speeds, about 500 nmi/hr, than the predecessor aircraft. Supersonic transports (SSTs), introduced in the 1970s, cruise at yet higher altitudes, FL450 to FL600, but are not major users of the NAT services.

Advancements in long-range navigation technology have introduced airborne navigation equipment that operate with more precision than the predecessor navigation methods. The modern sophisticated avionics equipment--Inertial Navigation System (INS) and a low-frequency radio navigation system with worldwide coverage and referred to as "Omega"--is now predominantly in use on jet aircraft in trans-Atlantic service and has allowed the phasing out of the LORAN A system.

Advancements in communications have been largely of an evolutionary refinement nature. These developments mainly involve improvements and modifications in existing equipment rather than major advancements in basic technology. Therefore, today's system continues to be based on HF voice communications.

2.2 Air Traffic Flow Patterns

The NAT air traffic is composed mostly of scheduled and charter air carriers but also includes military and high performance general aviation aircraft. Figure 1 shows the general origin and destination flow patterns of turbojet, high altitude air traffic through the NAT for a selected day in July 1979 (i.e., a representative busy day). The

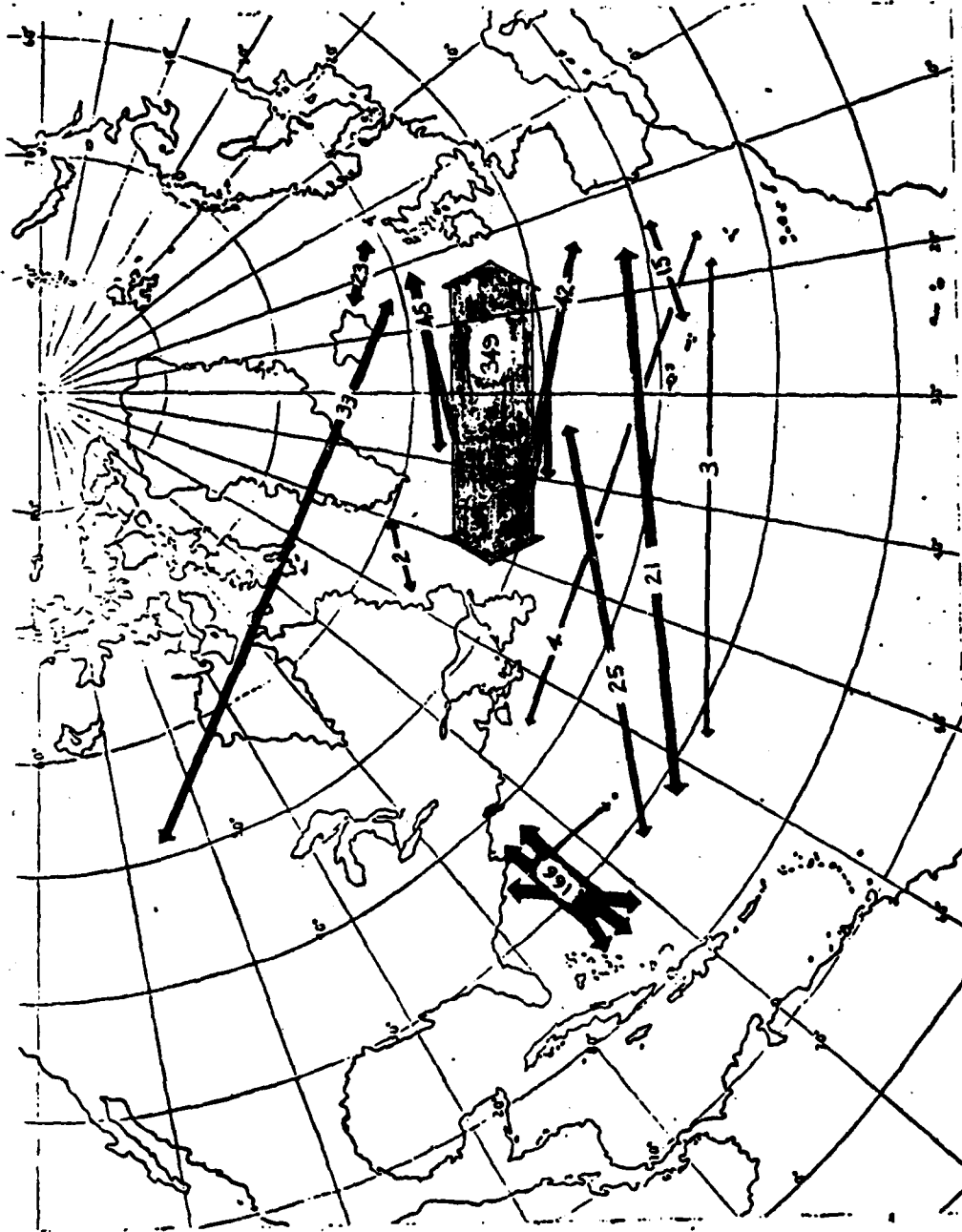

FIGURE 1. REPRESENTATIVE PEAK DAY NUMBER OF NAT FLIGHTS

numbers indicated in Figure 1 are the daily total eastbound and west-bound airline, general aviation and military flights for each geographic flow pattern, and are based on the published airline schedules and on records of actual flights flown on that day as obtained from all the ATS units serving the NAT.

Of the total of 728 daily flights shown, 48 percent (i.e., 349 flights) are concentrated in a major traffic flow between airports in the North America (east and midwest) region and the Europe (excluding Scandinavia and the Iberian Peninsula) and Middle East region. A secondary concentration involves 23 percent of the NAT traffic (166 flights) and is accounted for by flights between North America and locations in the Caribbean, South America and Bermuda. The other flows are of considerably less intensity (none of which individually involve more than 6 percent of the total traffic) and are accounted for by flights with origins or destinations in North America (west), Scandinavia, the Iberian Peninsula, North Africa, the Azores, Greenland and Iceland in addition to the above mentioned regions.

The major traffic flow, because of passenger preference, time-zone differences and restrictions on nighttime jet airport operations, consists of two distinct traffic surges: one westbound leaving Europe in the morning and early afternoon and the other eastbound leaving North America in the evening. The route and altitudes desired by each flight is defined by the aircraft operator, usually an airline. A prime consideration of the route preference is the upper air circulation patterns, which determine the most efficient flight paths. The major trans-Atlantic traffic flow generally runs between Newfoundland and the British Isles.

The major traffic flow is roughly paralleled by lesser traffic flows between North America and Scandinavia and between North America and the Iberian Peninsula. However, depending on meteorological conditions, these flows may cross or merge with the major traffic flow.

The traffic flow between North America and the Caribbean-South America-Bermuda area is more disperse than the major traffic flow and is not confined to any single, clearly defined flow corridor. The traffic is generally north-south in orientation, but with individual flight routes often crossing each other because of the location of the origin and destination airports. These flights normally involve shorter ranges than the other NAT traffic.

Many of the lesser traffic flows, as indicated in Figure 1, cross each other depending on upper air circulation patterns and the location of origins and destinations. These flows could also cross the major traffic flow. For example, flights from the Caribbean to the British Isles can cross the eastern part of the major traffic flow as do flights from the West Coast of North America.

Trans-Atlantic propeller traffic is confined to low altitude airspace and does not interact with the high level turbojet traffic. There are far fewer propeller aircraft than turbojet aircraft flying in the NAT; therefore, they do not generate a relatively significant demand for traffic service. Because of the dominance of subsonic turbojet traffic, the remainder of this ATS system description will focus on the traffic services provided in high level NAT airspace. Supersonic turbojet flights, which occur infrequently, fly at higher oceanic altitudes than subsonic aircraft.

2.3 Airspace Organization and ATS Facilities

The NAT airspace jurisdictional structure is shown in Figure 2, which identifies the CTAs and FIRs established by international agreement and described by the ICAO Air Navigation Plan for the NAT (ref. 5). Table 1 lists the NAT designated oceanic areas; ATS operating units; unit responsibilities; unit locations; and provider authorities and contracting states.

The NAT's major traffic flow between North America and Europe runs through the Gander CTA/FIR and Shanwick CTA/FIR. Therefore, air traffic in the NAT is handled primarily by the Gander ACC, Newfoundland, Canada, and the Shanwick OACC, Prestwick, Scotland. The remaining NAT traffic is handled by the Santa Maria (Azores), Reykjavik (Iceland), Sondrestrom (Greenland), Bodo (Norway), and New York, San Juan and Miami (United States) ATS units.

As shown in Figure 2, the Gander ACC is responsible for high and low oceanic airspace west of 30 degrees West longitude and domestic high and low airspace over Newfoundland. The Gander ACC's jurisdiction also includes high level airspace--above FL195--over southern Greenland. The Shanwick OACC is responsible for the high and low oceanic airspace east of the 30 degree West longitude, which is the boundary between the Gander and Shanwick CTA/FIRs. The New York, San Juan, Miami and Santa Maria ACCs share responsibility in the oceanic high and low airspace areas to the south, with the Santa Maria ACC responsible for the area east of 40 degrees West longitude. The Reykjavik ACC is responsible for high and low airspace to the east of Greenland and for the high airspace over northern Greenland. The Reykjavik CTA/FIR extends from Canada to north of Scotland. The low level airspace--below FL195--over Greenland is under the jurisdiction of the Sondrestrom FIC which provides flight information service but does not provide ATC service in its FIR. Similarly, the Bodo FIC does not provide ATC service in its FIR, which is a wedge of oceanic high and low airspace west of Scandinavia. The terminal control areas (TMAs) and their associated domestic CTAs shown in Figure 2 are not part of international oceanic airspace.

Because the Sondrestrom and Bodo FICs cover limited areas of airspace, and do not provide full ATS services nor handle a significant amount of turbojet air traffic, these centers will not be described in

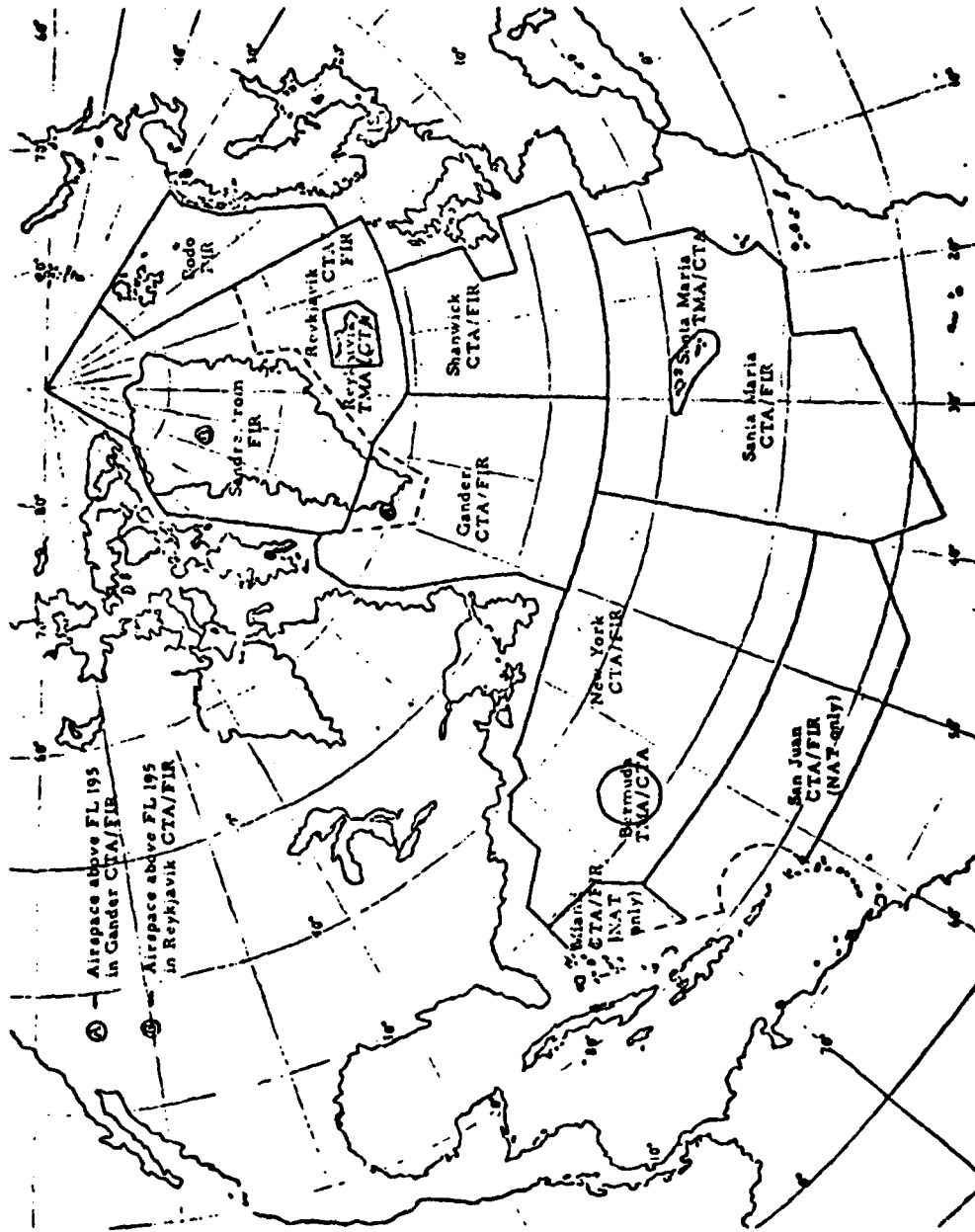

Source: ICAO DOC 8775/10,
NAT/NAN/PAC ANP (Sept. 1977)

FIGURE 2 NAT AIRSPACE

Table 1

NAT ATS ORGANIZATIONS AND FUNCTIONS

<u>Designated Oceanic Area</u>	<u>ATS Operating Unit</u>	<u>ATS Responsibilities*</u>	<u>Location</u>	<u>Provider Authorities Contracting States</u>
Gander CTA/FIR	Gander ACC	ATC FI ALERT	Gander, Newfoundland, Canada	Transport Canada, Canada
Shanwick CTA/FIR	Shanwick OACC	ATC FI ALERT	Prestwick, Scotland, United Kingdom	Civil Aviation Authority (CAA), United Kingdom
New York CTA/FIR	New York ACC	ATC FI ALERT	Ronkonkoma, New York United States	Federal Aviation Administration (FAA), Department of Transportation (DOT), United States
Santa Maria CTA/FIR	Santa Maria ACC	ATC FI ALERT	Santa Maria, Azores	Director General of Civil Aviation and Airports and Air Navigation Public Enterprise (ANA/EP), Portugal
Reykjavik CTA/FIR	Reykjavik ACC	ATC FI ALERT	Reykjavik, Iceland	Iceland
Sondrestrom FIR	Sondrestrom FIC	FI ALERT	Sondrestrom, Greenland	Danish Civil Aviation Authority (DCAA), Denmark
Bodo FIR	Bodo FIC	FI ALERT	Norway	Norway
San Juan CTA/FIR	San Juan ACC	ATC FI ALERT	San Juan, Puerto Rico	FAA, DOT, United States
Miami CTA/FIR	Miami ACC	ATC FI ALERT	Miami, Florida, United States	FAA, DOT, United States

*The ATS responsibilities include ATC, flight information (FI) and alerting (ALERT) services.

detail. The San Juan and Miami CTA/FIRs are included in ICAO's Caribbean/South American ANP (ref. 6), but, because the traffic handled in these areas is an integral part of the NAT operation, the San Juan and Miami oceanic CTA/FIRs are addressed in this description (exclusive of the San Juan and Miami ACCs responsibilities in the Caribbean Ocean and Gulf of Mexico). Therefore, the remainder of this ATS system description emphasizes the services provided in the following areas:

- (1) Gander Oceanic CTA/FIR
- (2) Shanwick Oceanic CTA/FIR
- (3) New York Oceanic CTA/FIR
- (4) Santa Maria Oceanic CTA/FIR
- (5) Reykjavik Oceanic CTA/FIR
- (6) San Juan CTA/FIR (NAT only)
- (7) Miami CTA/FIR (NAT only).

ATS in domestic airspace areas will be covered only in respect to their relation to oceanic operations.

2.4 Technical Systems Overview

Many of the ATS technical systems routinely used in domestic airspace are different from the technical systems used in oceanic operations, particularly in regard to the communication and navigation systems. For the most part, limitations on the service range of the domestic systems and the lack of land sites in the oceanic areas have precluded the extensive use of the domestic systems in the NAT.

For example, most domestic air-ground voice communications between pilots and ATS units are conducted by means of very high frequency (VHF) systems which, although quite adequate for domestic ATS purposes, cannot satisfy long-range transmission requirements. Although VHF communications is available in some parts of the NAT, an HF radiotelephony system is used more often. COM stations, rather than ATS units, conduct the VHF and the longer-range HF communications with over-ocean aircraft. Radio operators in the COM stations carry out these communications.

Aircraft navigation in domestic airspace normally uses ground-based systems of VHF omnidirectional range (VOR) and distance measuring equipment (VOR/DME) radionavigation aids or nondirectional beacon (NDB) aids and automatic direction finding (NDB/ADF) equipment. While NDB/ADF and VOR/DME systems are used to navigate some of the shorter routes in the NAT airspace, neither the VOR/DME nor the NDB/ADF systems can meet the long-range navigation requirements of many trans-Atlantic flights. INS and Omega systems are commonly used.

The radar systems used for domestic aircraft surveillance are not capable of long-range surveillance. No alternative technology currently is employed in the NAT for surveillance purposes, although, as will be noted, indirect flight monitoring is provided by pilot radio reports of aircraft positions.

2.5 Oceanic Route Structures

The flight operation environments in the various parts of the NAT airspace vary according to differences in traffic density, navigational services and associated procedures. Because of the differences in operating conditions, a variety of oceanic route structures are in use. These route structures are categorized as follows for the purposes of this study:

- (1) Charted tracks, including ATS routes and SST tracks
- (2) Random tracks
- (3) Organized track system (OTS).

The three types of oceanic routes and their applications in the NAT are briefly reviewed in the following paragraphs.

2.5.1 Charted Tracks

The VOR/DME and NDB/ADF navigation techniques require aircraft to fly directly to or from a ground based radionavigation aid or an intersection based on a system of aids. A VOR/DME or NDB/ADF track often is formally designated between two fixes for the purpose of organizing traffic flow. This track is geographically stationary and is identified as a fixed route in aeronautical charts. A charted track is a single route between two fixes and normally is not part of a set of offset parallel tracks. However, offset parallel tracks may be flown by aircraft equipped with special avionics systems such as area navigation (RNAV) systems including INS.

In certain cases, the charted tracks not only are published but also are physically maintained by ATS provider authorities who routinely flight-check the radionavigation aids. Such ATS routes often employ smaller lateral separation minima than those generally used on non-ATS tracks. Oceanic ATS routes based on NDB/ADF and VOR/DME radionavigation aids, upon which reduced lateral separation standards are applied, are established in the western part of the New York CTA/FIR, as shown in Figure 3.

The ATS routes in the New York CTA/FIR are used by subsonic jet aircraft. Other tracks published in aeronautical charts and used by subsonic aircraft include the charted tracks that connect radionavigation aids located in Northern Europe, Iceland, Greenland and Northern

Canada, and connect radionavigation aids located on the Iberian Peninsula and the Azores. The navigation accuracy of the NDBs in the northerly NAT airspace in the Greenland vicinity is often degraded because of erratic propagation patterns caused by frequent static disturbances (ref. 11).

Two published fixed tracks between Northern Europe and North America are used strictly by SSTs; the SST tracks are shown in Figure 4. The SSTs cruise well above the altitudes flown by subsonic aircraft, and do not interfere with the oceanic subsonic traffic. The ends of the SST tracks join the domestic route networks of Europe and North America, and oceanic flights along these tracks require long-range navigation techniques such as INS.

2.5.2 Random Tracks

Aircraft are not required to fly the charted tracks but often do so when constrained by navigational capabilities and ATC procedural restrictions, or to take advantage of the reduced aircraft separation requirements on the ATS routes. Aircraft fly on random tracks when conditions warrant flying off charted tracks (i.e., to minimize time and fuel burn), or when flying between points where no formal tracks are defined (such as between Europe and the Caribbean). A random track is selected by an aircraft operator based on available navigation services and upper air conditions, and is designated for an individual flight. Random tracks in the NAT normally are flown by INS or Omega equipped aircraft, although less sophisticated navigation techniques may be used where permitted.

2.5.3 Organized Track System (OTS)

While no charted fixed tracks serve the major traffic flow, an OTS is constructed twice daily based on aircraft route preferences. The OTS consists of a set of roughly parallel tracks with eastbound and westbound altitude assignments as exemplified in Figure 5. The track locations and altitude assignments are made such that the lateral and vertical separation minima are satisfied at all points along each track. The OTS is constructed once a day by the Gander ACC for the eastbound traffic surge and once a day by the Shanwick OACC for the westbound surge.

In both cases, the OTS track locations and altitude assignments are based on forecasts of the upper air circulation system. These winds move from west to east in complex geographic patterns with variations in velocity. The upper air system contains regions of significant wind velocities, including the jet stream. This stream is a relatively narrow core of winds, usually of very significant velocity, is almost always present, and often follows a wandering course. Eastbound aircraft prefer to be in the region of the most significant wind

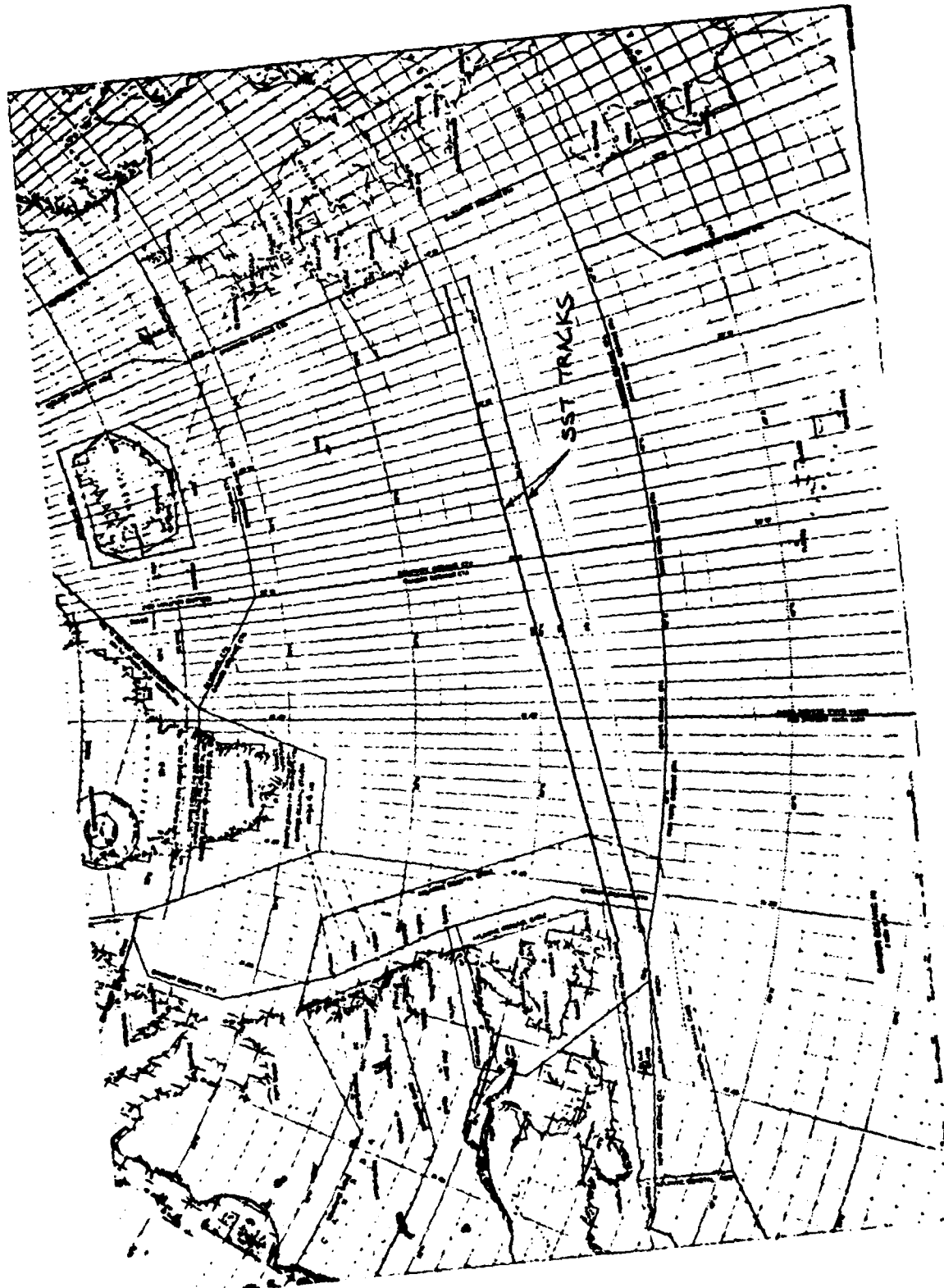

FIGURE 4. MAT SST TRACKS

Source: Gender ACC

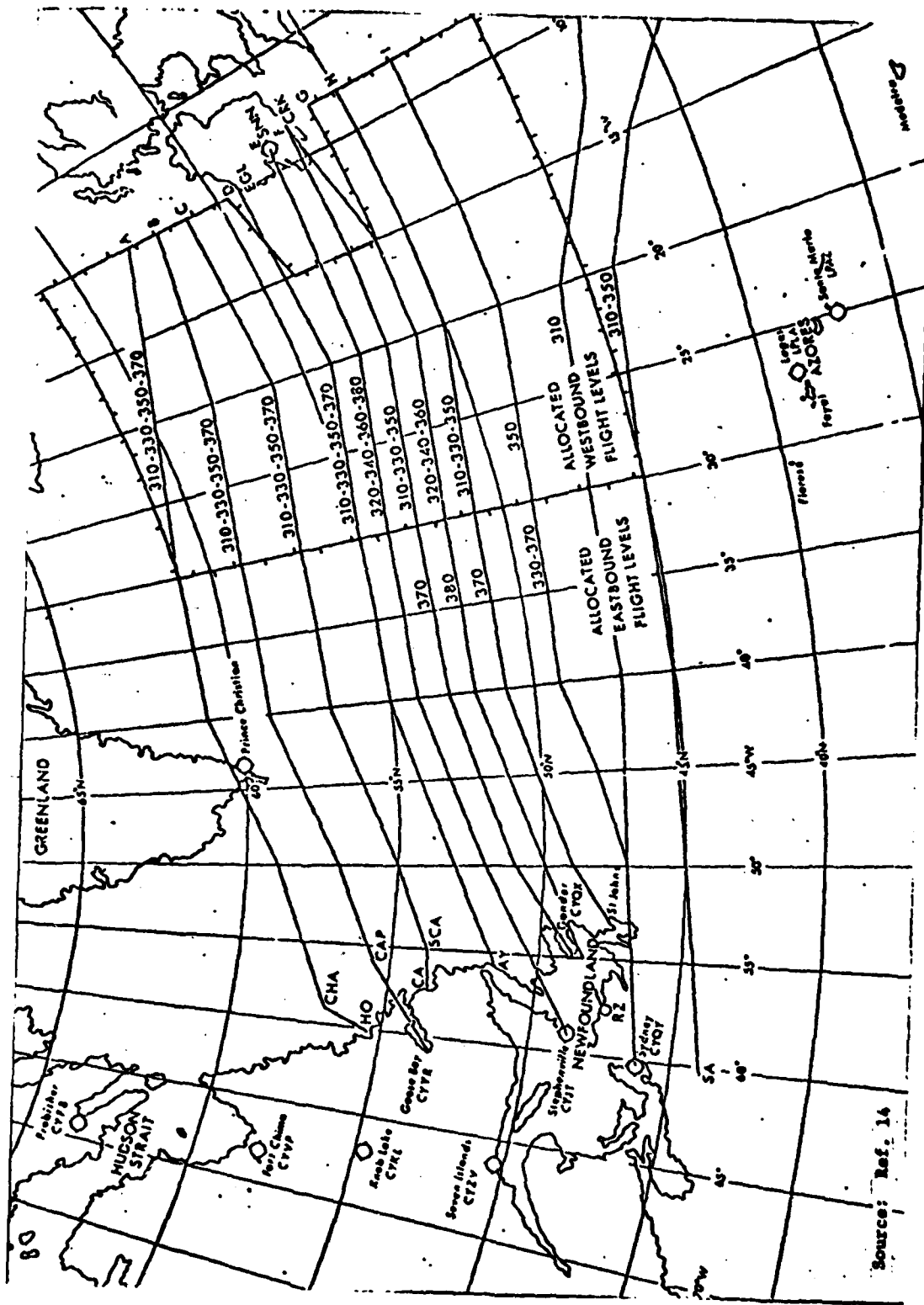

FIGURE 5 OTS EXAMPLE (WESTBOUND TRAFFIC FLOW)

velocity in order to use the tail wind component to increase flight efficiency. Westbound aircraft, in order to avoid a severe head wind component, fly either North or South of the most significant winds (or, in some cases, perpendicular to them) depending on their location.

The OTS is placed coincidentally with the forecasted significant winds to accommodate the eastbound surge, and is located away from the significant winds to accommodate the westbound surge. Because the location of the significant winds is nearly always changing, the OTS structures for the eastbound and westbound flows are not identical from day to day. On those infrequent occasions when the wind velocities are very low or there are no significant wind patterns at all, the OTS structure consists of a great circle-like path between the airports serving the major traffic flow.

Each end of an OTS track is designated by a "coast-in" or "coast-out" fix defined by a navigation fix (i.e., an actual radionavigation aid site, an intersection of radials off navigation aids, or an intersection of latitude and longitude). The coast-in and coast-out fixes are also part of the domestic routing system and therefore are the points of actual connection between the oceanic and domestic routes. Segments of the domestic route system are formally designated as the preferred routes for approaching and departing each coast-in and coast-out fix from selected points in the domestic network, including major airports.

Various airlines routinely submit preliminary preferred track descriptions to the Gander ACC and Shanwick OACC. These units use these tracks and their own analysis of the meteorological forecasts to design the OTS. Then, descriptions of each domestic transition route, oceanic track, direction of oceanic flight by altitude, and the effective time of the OTS are published separately by the Gander ACC and Shanwick OACC in the OTS teletype "track messages" (or "signals"). The track message is distributed prior to OTS establishment and is forwarded to airline and military flight planning offices and ATS units that use the OTS information to plan daily operations.

2.6 ATS Operating Procedures

Most airline operators plan their flight tracks and altitudes to minimize fuel consumption. A flight plan filed by an airline results from a computerized analysis of aircraft weight, speed, distance, weather and related flight conditions, as well as the fuel requirements associated with alternative flight paths; it identifies the track and altitude profile preferred by that airline. Flight plans filed by military and general aviation operators also are the results of structured flight planning procedures, although the primary consideration may be minimizing flight times rather than minimizing fuel burn. The filed flight plans are distributed to the domestic and oceanic ATS units along the flight routes.

2.6.1 Domestic Airspace Operations

A domestic ATS unit provides an aircraft with an abbreviated clearance to the destination airport, including a full clearance for the local domestic route system. The domestic (and oceanic) airspace areas are divided into sectors in which ATS are under the responsibility of sector controllers. The domestic sector controllers, who generally are supported by radar, VHF communications and VOR/DME navigation facilities, provide separation services based on considerably closer spacings than are currently required by oceanic procedures. Therefore, a transition from domestic to oceanic separations must be accomplished before aircraft enter the oceanic CTA/FIR. The transition process involves the issuance of a detailed oceanic clearance which includes the approved oceanic track and flight level needed to establish aircraft spacings that conform to the oceanic separation minima. This oceanic clearance may be a confirmation of the initial abbreviated clearance or a revision to it.

2.6.2 Oceanic Entry Operations

Various methods are employed at the NAT ATS units to determine and deliver oceanic clearances to aircraft entering the oceanic area. One method involves planners who manage traffic movement at the Gander ACC and Shanwick OACC. (Note: the New York ACC implemented a planner position in February 1980; this position is not addressed in this report which describes the state of the ATS system in mid-1979.) The planners determine the oceanic clearance for each aircraft prior to oceanic entry and also are responsible for the daily construction of the OTS. Each planner maintains a flight progress board that holds paper flight strips describing an aircraft's route, altitude, speed, equipment, and current and projected times of crossing selected position fixes. At the Shanwick OACC and Gander ACC, as well as at the New York, San Juan and Miami ACCs, the time estimates are generated by computer calculations which account for aircraft speed and forecast winds aloft. At the other NAT oceanic ATS units, the flight strips are prepared manually.

The planner uses the flight strip data to assess projected separations and to develop oceanic clearance strategies. The Gander ACC has a computerized conflict prediction function that automatically checks each planner's clearance decisions for eastbound flights as the clearances are entered into the computer data processing system.

The planner positions at Gander and Shanwick are not equipped with VHF radiotelephony capabilities and cannot directly contact aircraft approaching the oceanic airspace. Therefore, each clearance is passed to a clearance delivery position or to a domestic controller for voice transmission to the aircraft. The clearance delivery position reads the clearances over published VHF frequencies in response to pilot requests.

The oceanic entry clearances at the New York, Santa Maria, Reykjavik, San Juan and Miami ACCs are determined by an oceanic en route sector controller who also is responsible for providing ATS to aircraft in oceanic airspace. Similarly to the planners at Shanwick and Gander, the oceanic sector controller uses flight strip data to determine oceanic clearances that must be relayed to a domestic sector controller for VHF voice relay to an aircraft before oceanic entry.

Oceanic entry operations take into account both OTS entry clearance and non-OTS entry clearance. These two operations are discussed in the following paragraphs.

The clearance determination process may vary within an ATS unit depending on the type of traffic routing. An aircraft entering an OTS track for example is given an oceanic clearance that provides a conflict-free flight path (i.e., satisfies separation minima) from coast-out fix to coast-in fix. The OTS clearance assigns a single track and flight path for the entire oceanic airspace. This "landfall-to-landfall" oceanic clearance is issued by the ATS unit that has jurisdiction over the OTS entry airspace even though the clearance extends into the airspace of an adjacent unit.

The OTS clearance determination process is facilitated by the structure of OTS which automatically provides required lateral and vertical separations between aircraft assigned to a single track and altitude. Therefore, before clearing an aircraft for entry to a track and flight level, the planner or oceanic sector controller checks the flight strip data to verify that the longitudinal separation minimum will not be violated at each fix along the projected flight path including the coast-out fix. If no conflict exists, the flight path requested by the entering aircraft is approved. If a potential violation exists, the aircraft will be assigned to an alternative track or flight level, delayed or both. The flight path adjustments will be carried out before oceanic entry, usually under the supervision of a domestic radar controller.

If necessary, the pilot may negotiate the final clearance at the time of the VHF clearance delivery. Note that oceanic clearances issued before entry to OTS tracks do not include altitude changes in mid-ocean; such altitude changes, if desired, must be requested by pilots before the desired time of climb and approved or denied by oceanic sector controllers.

For aircraft about to enter the non-OTS tracks, the oceanic clearances also are determined by the planners at Gander and Shanwick and the oceanic sector controllers at the other NAT ATS units. Unlike the OTS tracks, non-OTS tracks are not automatically provided with required lateral and vertical separations between each other. Therefore, each non-OTS track must be searched for potential violations of lateral and vertical as well as longitudinal separation minima. For example, the

search for potential crossing or overtaking conflicts on the ATS routes in the New York CTA/FIR involves reviewing the flight strip data showing the estimated times of crossing of published fixes in this airspace. In the case of a random track, the proposed flight path through the CTA/FIR is projected and compared against other tracks in this area in order to determine potential conflicts. The ATS units are equipped with plotting maps that may be used when necessary to manually draw the random tracks. As in the case of the OTS tracks, potential conflicts are resolved by diverting or delaying aircraft, or both.

The planners and oceanic sector controllers normally do not have extensive information describing all non-OTS aircraft flight plans in areas outside their jurisdiction and often cannot develop landfall-to-landfall clearances for non-OTS aircraft. Therefore, oceanic entry clearances for non-OTS flights normally provide conflict-free flight paths only for that portion of each flight within the immediate area of jurisdiction and adjacent airspace. However, Gander and Shanwick have established special flight data exchange facilities (including a computer link) and use these facilities to provide complete conflict-free clearances for non-OTS oceanic flights within their CTA/FIRs.

2.6.3 Oceanic Airspace Operations

Once aircraft enter any of the NAT oceanic CTA/FIRs, they are monitored by an oceanic en route sector controller in order to assure that the required minimum separations are maintained. Pilot position reports are transmitted by HF or VHF voice communications directly to radio operators in COM stations who relay the reports to ATS units, normally by teletype. The monitoring process is conducted by copying position reports onto flight strips and then comparing the relative positions of the aircraft against the separation minima. Current ICAO procedures call for the aircraft to report at least once an hour if possible. Reporting fixes are located at the intersection of flight tracks and ten degree longitude lines or five degree latitude lines depending on east-west or north-south direction. The information transmitted in each position report includes the aircraft identity (e.g., airline and flight number), the identity or position of the reporting fix (i.e., latitude and longitude) and the time of crossing, the flight level, the next fix identity or position, and the estimated time for crossing the next fix. In the event of a potential violation to the separation minima, the oceanic controller may relay a clearance through the radio operator to the aircraft to change route, altitude, or speed. Similarly, requests for altitude change or other flight plan changes are relayed through COM station radio operators, as are the oceanic sector controllers' responses to such requests.

The COM station operators also relay messages to and from pilots that do not directly involve the ATS units. Such messages include company and meteorological data transmissions.

2.6.4 Oceanic Exit Operations

Aircraft flying through NAT airspace may pass through more than one oceanic CTA/FIR jurisdiction before reentering domestic airspace. The domestic reentry process may be less restrictive than oceanic entry because the reduced domestic separations relieve the spacing constraints imposed by oceanic separation minima, and radar coverage normally is available to facilitate control maneuvers.

3.0 ATS TECHNICAL STRUCTURE

3.1 Introduction

The NAT communications systems, navigation systems, and surveillance systems are reviewed in this section. Meteorological systems are described in Appendix J.

3.2 Communications Systems

ATS data transmission functions are provided by aeronautical mobile and aeronautical fixed communications systems. The mobile systems provide air-ground voice communications between aircraft and ground stations, whereas the fixed systems provide voice and teletype and other data link communications between various ground facilities. The ground facilities include the ATS units, aeronautical COM stations, flight operations offices, meteorological centers, search and rescue centers, and associated facilities that participate in or support the ATS operation. The ATS communications system is reviewed in the following paragraphs.

3.2.1 Aeronautical Mobile Communications

Air-ground voice communications in domestic and oceanic airspace are conducted by short-range VHF and ultra-high frequency (UHF) facilities and by long-range HF facilities. UHF is used by some military operators. The relatively short range of VHF and UHF systems is due to the line-of-sight nature of the transmissions and the power applied. Most VHF ground transmitters are omnidirectional with a range of about 200 nmi at FL300. Extended range VHF, which is accomplished by concentrating the transmissions in a particular direction and increasing the transmitter power, can achieve a coverage distance of 400 nmi at FL300.

Because of the universal application of VHF systems in domestic airspace, all aircraft carry VHF equipment. Although the VHF system is used mostly for voice communications, some commercial aircraft under U.S. registry carry special purpose VHF data link equipment--ARINC Communications Addressing and Reporting System (ACARS)--to automatically transmit operational data to airline ground units.

Each domestic ATS communications system includes a network of transmitter and receiver ground sites which are connected to ATS operating units and are strategically located to provide continuous domestic airspace radio coverage. Similar aeronautical communications networks are established and operated by airlines for company use. The ATS transmitter and receiver stations are located only on ground sites, and none

are located in oceanic areas on platforms or stationary vessels. Such facilities are not used due to the technical and economic difficulties in placement, stabilization, operations and maintenance, communications relay to ground stations, and electric power supply. Furthermore, the present capability to economically cover a broad oceanic region devoid of numerous land sites with surface transmitters and receivers is questionable when considering that each such station could cover an area of only 200 to 400 nmi in radius. (These difficulties likely also have precluded the use of oceanic platforms and vessels for navigation and surveillance purposes.)

Coastal VHF transmitter and receiver ground sites located along the NAT region and operated by ATS units provide shortrange radiotelephony service between controllers and aircraft transitioning between domestic airspace and oceanic CTA/FIRs. The extended range VHF facilities are operated by COM stations and provide voice contact between pilots and radio operators.

Figure 6 shows the approximate VHF coverage provided in the NAT region. Nearly continuous VHF radiotelephony service is provided by standard and extended range VHF ground sites located across the corridor of airspace extending from North America to Europe over Greenland and Iceland. This VHF airspace normally does not coincide with the location of the major traffic flow between North America and Europe. Radiotelephony in the heavily traveled corridor and the vast expanse of the NAT region is provided only by HF communications systems.

HF transmission characteristics enable over-the-horizon voice transmissions between aircraft and HF ground stations. HF transmitters and receiver ground sites are located along the coast of North America, Europe, and the Azores and provide long-range radiotelephony coverage of the NAT airspace. The COM stations that operate the HF systems generally are separately located from ATS units that they support. The major COM stations (exclusive of military facilities) are listed in Table 2.

The HF transmissions are subject to interference by atmospheric disturbances that degrade voice quality and restrict range. However, the availability of multiple frequencies and the recent introduction of single side band (SSB) HF modulation have been useful in partially overcoming the HF signal propagation problems. SSB also affords the capability to increase the number of HF channels available for future use.

3.2.2 Aeronautical Fixed Communications

ATS units, COM stations, aircraft operations offices and other ground units communicate with each other by means of specially provided communications networks. The networks include landlines and marine cables, satellite relay, HF point-to-point channels, and switching mechanisms for routing messages through facilities. The links may be

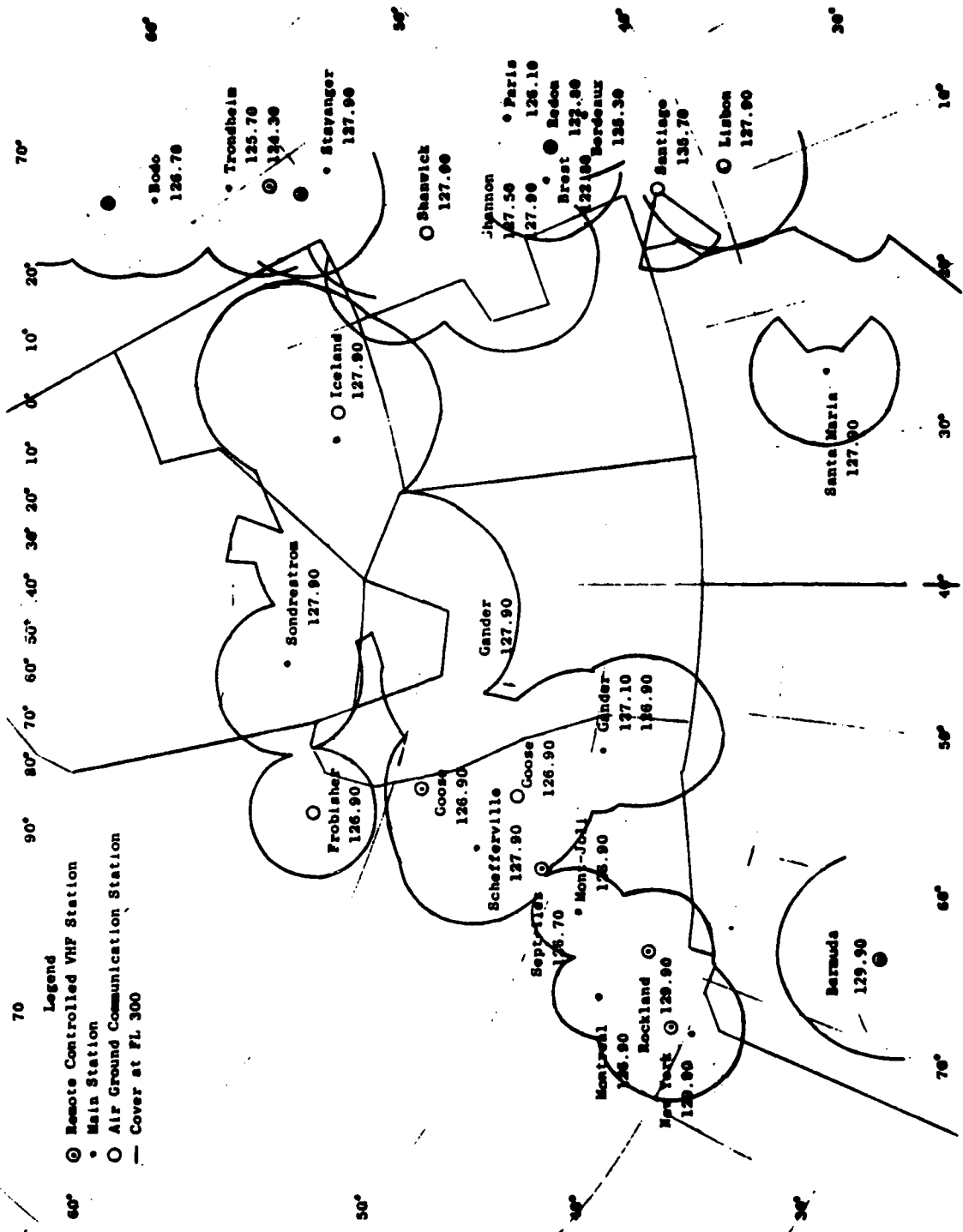

FIGURE 6. ESTIMATE OF VHF COVERAGE OF THE NORTH ATLANTIC AT 30,000 FEET

Table 2

MAJOR COMMUNICATIONS STATIONS IN SUPPORT OF NAT OACC/ACCS

<u>Communications Stations</u>	<u>Air/Group Communications Facilities</u>	<u>Location</u>	<u>Primary Coordinating ATS Unit</u>
Gander Aeradio	VHF, HF, ERVHF*	Gander, Newfoundland, Canada	Gander ACC
Shannon	VHF, HF	Ballygirreen, Ireland	Shanwick OACC
New York ARINC	VHF, HF	Ronkonkoma, New York United States	New York ACC Miami ACC
Santa Maria	VHF, HF, ERVHF*	Santa Maria, Azores	Santa Maria ACC
Gufunes	VHF, HF, ERVHF*	Gufunes, Iceland	Reykjavik ACC
San Juan ARINC	VHF, HF	San Juan, Puerto Rico	San Juan ACC

* ERVHF: Extended Range VHF.

dedicated to voice or data transmission or shared by each and, for the most part, are leased from commercial services such as post, telegraph and telephone (PTT) services.

The fixed communications system includes the aeronautical fixed telecommunications network (AFTN), ATS direct speech circuits and miscellaneous circuits used as circumstances warrant for interfacility computer data exchange, meteorological data distribution and the like.

The AFTN distributes teletype messages to interconnected oceanic and domestic facilities. The NAT facilities are linked largely by a system of leased PTT landlines and marine cables, but HF SSB and leased satellite communications channels are used for links to the Santa Maria OACC. The AFTN messages are sent from and received at teletype terminals located in each facility.

The ATS direct speech interphone circuits provide for voice communications between the ATS, COM and other ground units. ATS units are linked to each other, normally by leased landlines or marine cables; HF SSB and satellite channels also provide service to the Santa Maria OACC from other NAT units. In some cases, ATS direct speech requires a relay through an intermediary. For example, voice conversations conducted between the Gander ACC and the Santa Maria OACC are relayed through the New York OACC which provides circuit switching.

In addition to the AFTN and ATS direct speech circuits, a computer-to-computer data link between the Gander ACC and the Shanwick OACC transmits digital information on a regular basis. The data link is by landlines and undersea cables.

The aeronautical fixed communications systems are not constrained by ground site requirements as is the VHF mobile communications system. The number of circuits in use may be increased, within the limits of economic and technical feasibility, by buying or leasing additional landlines, marine cables, or satellite circuits. Expansion of the fixed communications system could involve the application of currently available advanced technology in addition to the increased use of current methods. For example, the ICAO Automated Data Interchange System (ADIS) Panel has developed procedures for using a high-speed packet switching network that is planned to replace the current AFTN equipment serving the NAT region in Europe and North America (ref. 12).

3.3 Navigation Systems

The great lengths of the over-ocean routes typically flown in the NAT normally require a long-range navigation capability. However, long-range navigation is not the only means for flying in the NAT. Where suitably located ground sites are available, short-range radionavigation aids are installed to support air traffic movement. The following paragraphs provide a brief perspective on navigation in the NAT.

3.3.1 Long-Range Navigation

Aircraft flying through the upper airspace of the Gander and Shanwick CTA/FIRs and major parts of the other NAT CTA/FIRs are required by ATS procedures to satisfy a stipulated navigational precision standard known as the minimum navigation performance specification (MNPS). Presently, INS and Omega navigation systems satisfy the specification, and most aircraft use these techniques. Elsewhere, aircraft may use the long-range navigation technique of their selection including Loran C, doppler and celestial navigation.

3.3.2 Short-Range Navigation

Short-range navigation service is provided by the VOR/DME radio-navigation aids which typically have an effective range of approximately 200 nmi at FL300 based on VHF line-of-sight and transmission power limitations. Because the aids are the basis for the domestic systems of jetways and airways, virtually all aircraft flying oceanic routes are equipped with VOR/DME avionics units.

VOR/DME navigation aids located along the coasts of North America and Europe and in Iceland and the Azores provide position information to aircraft transitioning between oceanic and domestic airspace. This network of VOR/DME aids is used to establish precise navigational reference points for the start and end of oceanic flight routes. The range of each of the VOR/DMEs in the NAT is such that extended and continuous oceanic navigation along a series of navigation aids is not possible. The lack of land sites precludes the general expansion of the VOR/DME network in the NAT into a fully connected oceanic navigation system.

Ground-reference navigation service of comparable or longer range but less precision than the VOR/DME aids is provided by the NDB aids. The effective navigational range of an NDB aid is determined by the power sizing designed for the individual site, and this range varies among the individual units in the NAT. NDB radionavigation aids are stationed along the eastern and western coasts of the NAT and in such locations as Greenland, Iceland, Bermuda and the Azores.

3.4 Surveillance Systems

Radar is available only in domestic airspace where suitable land sites exist for antenna location. The systems typically used for ATC surveillance include primary radar--which tracks aircraft skin reflections ("skin paint") of the radar signals-- and secondary surveillance radar (SSR)--which tracks aircraft beacon responses to radar interrogation. The ground antenna transmits and receives signals which are limited by line-of-sight and transmission power constraints. Therefore, the effective coverage area normally extends only 200 nmi at FL300 beyond the land-based sites, as indicated in Figure 7 for the NAT region.

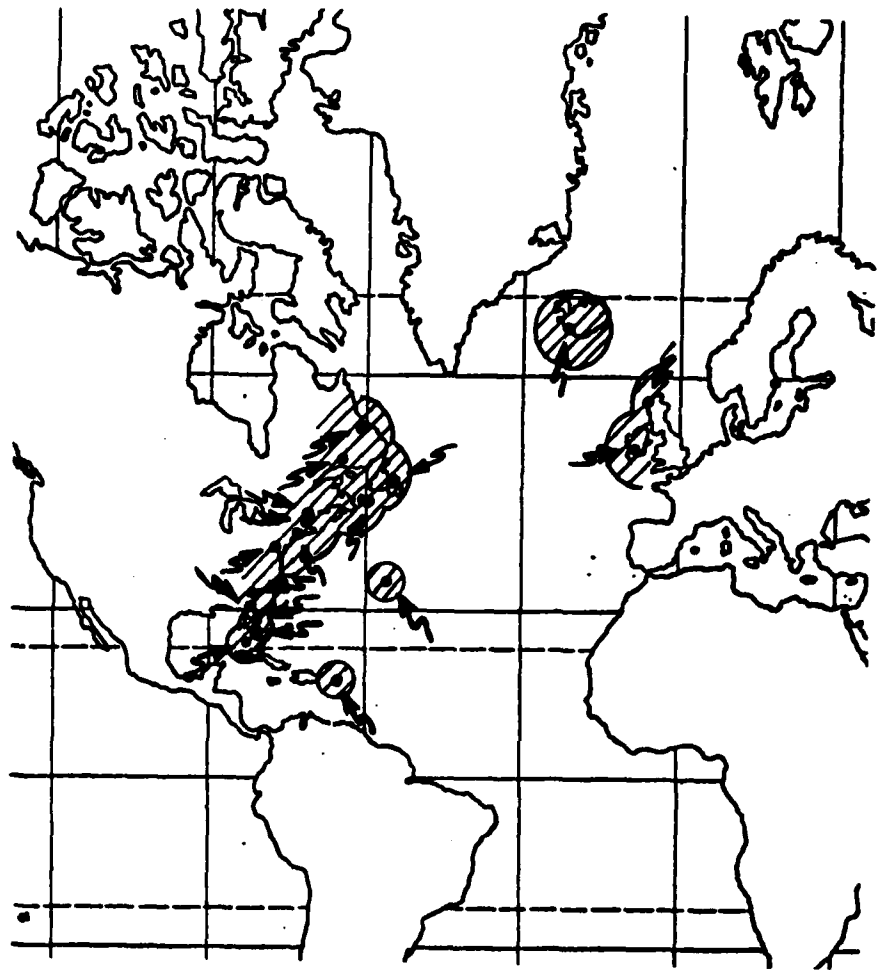

FIGURE 7 APPROXIMATE RADAR COVERAGE AT FL300--NAT (INCOMPLETE)

4.0 SEPARATION MINIMA

4.1 Separation Minima Determination

The separation minima applied in the NAT are established by agreements of the ICAO contracting States of the region. The agreements are made under the auspices of ICAO and involve specially designated coordination organizations such as the North Atlantic Systems Planning Group (NAT/SPG) whose members include representatives of ATS providers and users. These groups conduct and review analyses of operating practices and identify and recommend procedural changes and appropriate revisions to existing separation minima.

The separation minima for the basic dimensions--vertical, lateral, and longitudinal--are based on the concept of defining protected volumes of airspace around individual aircraft by taking into account the performance capabilities of navigation, communication, and surveillance systems, and the ability of the ATC system to apply separation services. In regard to separation procedures, ATC operations and rules are based on the premise that navigation responsibility is vested with the aircraft and that controllers normally do not assume responsibility for navigating aircraft except in certain circumstances (e.g., radar surveillance) where the ATC system has better quality position data than does the aircraft (ref. 3).

In the NAT oceanic airspace environment where radar surveillance and direct pilot-controller communications are not available, the capabilities of the navigation equipment and position reporting and monitoring procedures have particular importance in regard to methods for defining the rules of keeping aircraft separated. The accepted guidelines for defining horizontal separation minima are stated by ICAO (ref. 3, Attachment A) as quoted below:

The determination of the longitudinal separation minima is based on the quality of information available to the responsible air traffic control organization.

The determination of lateral separation should be based primarily on the accuracy with which pilots can adhere to an assigned track. In many cases lateral separation minima are stated in terms of the width of the airspace to be protected along any given route or airway.

The current longitudinal separations used in the NAT are based on conflict-free flight path clearances, and are not dependent on position reports and controller monitoring of aircraft in oceanic airspace.

Hence, the relative capabilities of aircraft navigation systems, the communication system, and the ability of controllers to prevent separation violations are reflected in the longitudinal separation minimum that have been defined by mutual agreement.

The lateral separation minimum is based on analysis and assessment of the navigational accuracy of aircraft flying in the NAT. A specifically developed collision risk model is used to evaluate the effects of lateral deviations relative to a target level of safety. Current agreement requires a target level of safety value of 0.2 fatal accidents per 10 million flying hours as the basis for assessing lateral spacing requirements (ref. 13).

The vertical separation minimum applied in high level airspace reflects the assumptions concerning height measuring accuracy of the altimetry equipment currently available.

4.2 NAT Separation Standards Documentation

The NAT region's separation minima as applied in mid-1979 and as stipulated in the ICAO Document 7030 (ref. 4) are presented in Appendix I and thus will not be detailed in this section. Instead, the basic characteristics of the separation minima and their application in the NAT are summarized in the following paragraphs. Some additional details describing local variations in the separation minima and their applications are included in Appendix B, which addresses the Shanwick OACC.

4.3 Vertical Separation

Subsonic jet aircraft routinely cruise above FL290 where the vertical separation minimum is 2,000 ft. Below FL290, the vertical separation minima is 1,000 ft. Above FL450, 4,000 ft is required between SST aircraft and any other aircraft. In standard noncomposite practice, subsonic IFR aircraft in cruise are assigned altitudes of odd or even flight levels (i.e., FL180, 190, 200...280) below FL290 and odd flight levels (i.e., FL290, FL310, 350, 370) above FL290; aircraft may step climb between such flight levels when cleared to do so. ATS procedures permit cruise climb operations (i.e., constant ascent rather than step climb) on the higher altitude (i.e., FL450 to FL600) SST tracks where low traffic density allows this technique.

4.4 Lateral Separation

Except for the NDB/ADF-based ATS tracks in the New York CTA/FIR, the minimum lateral separation between subsonic aircraft flying at the same flight level is 120 nmi. Consultations with New York ACC personnel found that the 90 nmi lateral spacing is applied between aircraft on adjacent ATS routes and between an aircraft on an ATS route and one on a random track.

Note that the basic 120 nmi minimum that currently is practiced in most parts of the NAT airspace is greater than the formal 90 nmi rule specified in the ICAO Regional Supplementary Procedures (ref. 4) for turbojet aircraft operating south of the 70 degree North latitude. The 90 nmi rule was objected to in the past by the pilots' union.

A lateral separation of 60 nmi is required between SST aircraft operating at or above FL450.

4.5 Longitudinal Separation

A 15 min longitudinal separation is required between subsonic turbojet aircraft operating at the same flight level provided that:

- (1) The "Mach number technique" is applied, and
- (2) The aircraft concerned have reported over the same entry point into the oceanic airspace and are on the same track or continuously diverging tracks (ref. 4).

The Mach number technique requires aircraft to adhere to an ATC cleared Mach number (ref. 3). The 15 min minimum also applies to aircraft not reporting over the same entry point but that are established with proper time intervals on oceanic courses under radar coverage (ref. 4).

The 15 min separation applied under the Mach number technique and track requirements stated above may be reduced to the following separations as stipulated in the ICAO Regional Supplementary Procedures (ref. 4):

10 minutes at the entry point into oceanic controlled airspace if the preceding aircraft is maintaining a speed of at least Mach 0.03 greater than that of the following aircraft.

5 minutes at the entry point into oceanic controlled airspace if the preceding aircraft is maintaining a speed of at least Mach 0.06 greater than that of the following aircraft.

In general, the 15 min longitudinal separation and Mach number technique are applied to aircraft entering OTS tracks and ATS routes and to aircraft conducting altitude changes on the OTS tracks only. The 5 and 10 min reduced separations are not applied to aircraft conducting altitude changes. The New York ACC personnel report that a 20 minute longitudinal separation is applied between all aircraft entering the Santa Maria CTA/FIR except between those aircraft on OTS tracks.

A 20 min longitudinal separation is required between all subsonic turbojet aircraft not covered by the 15, 10, and 5 min separation rules addressed above (ref. 4). The 20 min separation applies to aircraft not

adhering to the Mach number technique requirements, to aircraft changing tracks or otherwise crossing, joining or leaving a track, and to the special circumstances noted in the preceding paragraph.

A 30 min longitudinal separation minimum is required between all nonturbojet aircraft except those operating on the ATS tracks in the New York CTA/FIR where a 20 min minimum is applied (ref. 4).

The longitudinal separation minima using the Mach number technique reportedly is increased to 20 min on the OTS in special circumstances during which technical services are degraded; such conditions include ionospheric disturbances causing HF radio blackouts (ref. 14).

To summarize, the separation minima results in a situation in which subsonic turbojet aircraft entering an OTS or ATS route and using the Mach number technique are subject to a 15 min longitudinal minimum applied at any point along the track including the exit point with allowances for reductions to 5 or 10 min at the entry point only. The only addition to the above in the application of the Mach number technique is the retention on the OTS only of 15 min separation between aircraft changing or having changed altitude. Otherwise the longitudinal minimum in all other circumstances for turbojet aircraft is 20 min. Nonturbojet aircraft are subject to a 20 min minimum on the ATS routes in the New York CTA/FIR and a 30 min minimum elsewhere.

In regard to supersonic flight, a 10 min longitudinal separation is applied to aircraft on the NAT SST tracks provided that:

...both aircraft are in level flight at the same Mach number or the aircraft are of the same type and are both operating in cruise climb; and the aircraft concerned have reported over the same entry point into the oceanic controlled airspace with a time interval of at least 12 minutes confirmed by radar observation and follow the same or continuously diverging tracks until another form of separation is established. (ref. 4).

The 10 min rule also applies to SST aircraft not reporting over the same entry point but that are established on oceanic courses under radar coverage with a proper time interval. Clearance to begin a deceleration/descent phase of flight may be issued to an SST while the 10 min separation minimum is in effect (ref. 4).

4.6 Composite Separation

Composite separation rules in the NAT are described by the following explanation (ref. 14):

A composite separation consists of a vertical minimum of 1000 ft combined with a lateral minimum of 60 miles, and may be used provided that:

It is used solely within the OTS.

It is applied only to aircraft at or above FL290.

Existing vertical separation minimum (i.e., 2,000 ft) is applied between aircraft on the same track.

Existing lateral separation minimum (i.e., 120 miles) is applied between aircraft at the same level on different tracks.

Composite separation may be applied between aircraft flying in the same or opposite directions. Flight levels representing even levels (e.g., FL320, 340, 360) are used on intermediate tracks inserted between the standard tracks which employ the standard odd levels (e.g., FL310, 330, 350, and 370) as shown in Figure 8. Composite separation was introduced in 1970 (ref. 10).

Longitudinal separations applied to aircraft on the composite tracks are the same as those minima described in the preceding paragraphs for the standard tracks including the application of 5 and 10 min reduced separations at track entry and strict 15 min separations for aircraft changing altitude on any single composite track.

4.7 Minimum Navigation Performance Specifications

In December 1977, ICAO introduced an MNPS for certain flights over the North Atlantic in the oceanic airspace between 27 degrees North and 67 degrees North latitudes east of 60 degrees West longitude and between FL275 and FL400 as shown in Figure 9. The specifications, which are described in Appendix I, require aircraft in the MNPS airspace to satisfy a level of navigation performance capability.

The MNPS has justified reductions in the separation minima based on the overall improvement in navigation precision. Studies conducted under the coordination of NAT/SPG have supported a recent NAT/SPG agreement to reduce the lateral and longitudinal separation minima to 60 nmi and 10 min, respectively, in MNPS airspace. The lateral separation reduction will achieve a system of uniform flight levels on each track rather than one similar to the current staggered arrangement of flight levels on adjacent tracks. The studies, which are continuing, address the incidence, detected by radar observation, of aircraft deviations from assigned tracks as flights transition from oceanic to domestic airspace.

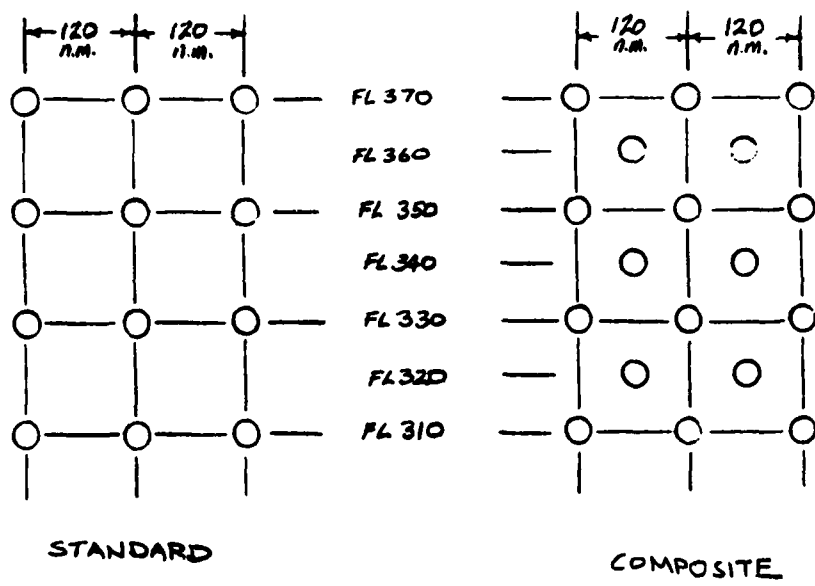
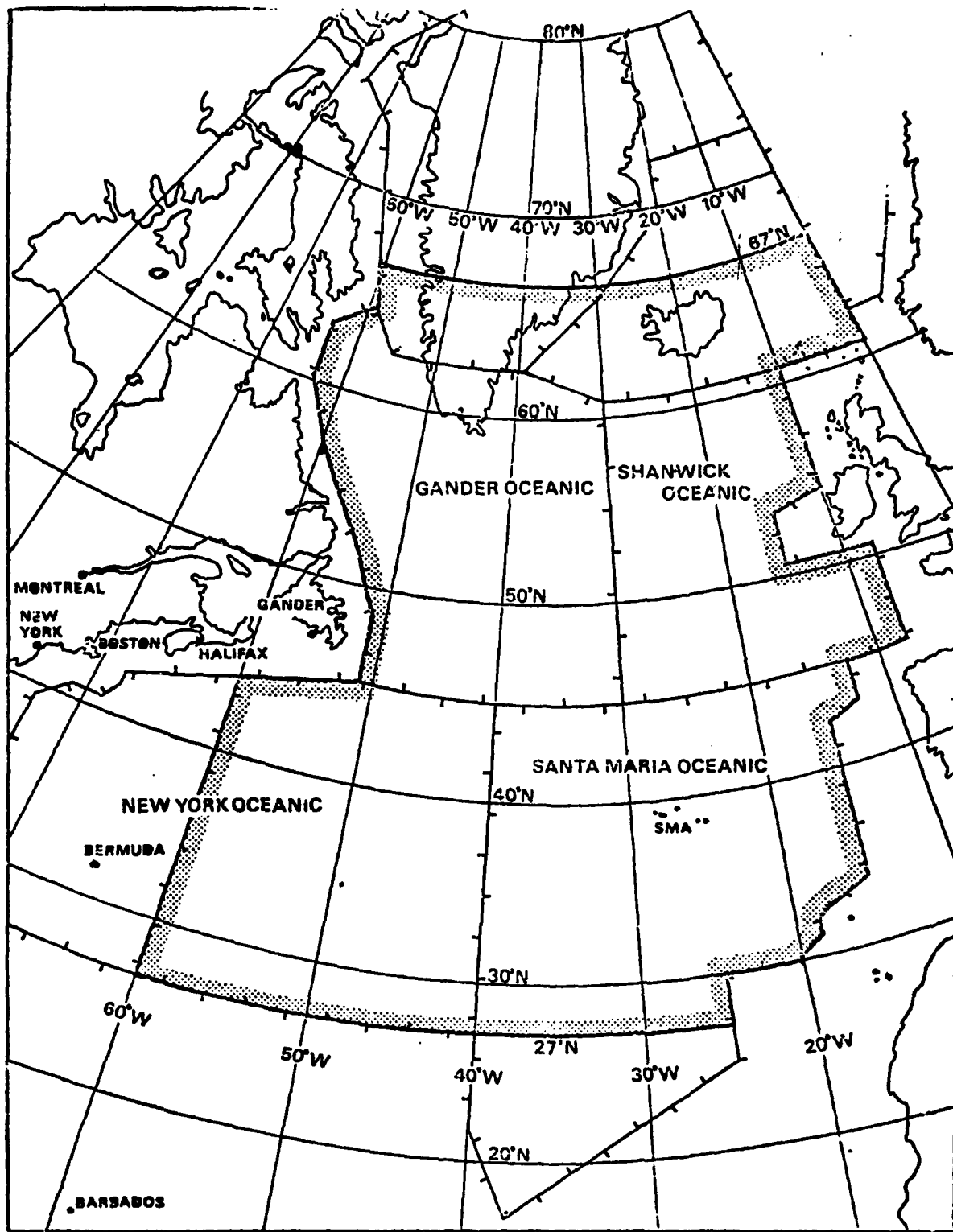

FIGURE 8 STANDARD AND COMPOSITE TRACK AND FLIGHT LEVEL SYSTEMS



Source: Ref. 14

FIGURE 9 NORTH ATLANTIC MNPS AREA

5.0 ORGANIZED TRACK SYSTEM

5.1 Historical Perspective

Prior to the mid-1950s, the propeller and turboprop aircraft traffic in the NAT airspace was relatively light and did not require flow regulation by advance planning. Flights in both directions were handled strictly on an ad hoc, first-come, first-served basis. However, subsequent increases in aircraft activity complicated the management of air traffic to the degree that a more formal airspace structure was required. In 1956, the Gander ACC and Prestwick OACC agreed to introduce the "datum line" strategy to handle the major traffic flow between Canada and Northern Europe (ref. 10).

The datum line was a boundary running from Europe to North America separating eastbound from westbound traffic and was negotiated by the two centers twice each day. The eastbound traffic generally was limited to the airspace at least 60 nmi to one side of the line, with the westbounds constrained similarly to the other side of the line. When necessary, two datum lines would be established with traffic in one direction flying between the two lines and the opposite direction traffic flying on either side (ref. 10).

The introduction of turbojet aircraft and the accompanying increase in traffic activity intensified the concentration of aircraft in the NAT airspace serving the major traffic flow. In 1961, the use of discrete tracks was instituted to manage and regulate air traffic and thereby inaugurated the OTS strategy (ref. 10).

The subsequent decrease in nonturbojet aircraft traffic obviated the need to regulate the traffic in the lower flight levels. The organized tracks, as a result, are used only for subsonic turbojet aircraft and covers the airspace from FL310 to FL370 (ref. 10).

5.2 OTS Establishment Guidelines

The predominantly eastbound OTS is established during the 9 hr period from 2300 Greenwich Mean Time (GMT) to 0800 GMT, while the predominantly westbound OTS is established during the 11 hr period from 1000 GMT to 2100 GMT. The westbound OTS is in effect for a longer period than the eastbound one because of the broader time spread and slower ground speed of the westbound traffic. The 2 hr transition periods between the OTS establishments occur during lulls in traffic activity during which time aircraft generally are exiting the system.

The planning of the eastbound OTS by the Gander ACC typically is initiated 12 hr before the time of actual establishment and is concluded at least 9 hr (normally about 10 hr) before OTS implementation (ref. 10). Therefore, the teletype track message describing the eastbound OTS is distributed from Gander over the AFTN at about 1300 GMT. The planning of the westbound OTS by the Shanwick OACC also is initiated about 12 hr before track implementation and the track message normally is issued after 0000 GMT.

Operational practices in the Gander and Shanwick CTA/FIRs require that aircraft be provided with clearances for the entire portion of flight between the landfall coast-out and coast-in fixes--or to 60 degrees West for westbound tracks north of the PRAWN intersection, as shown later in Figure 13 (ref. 11)--and require aircraft to provide a position report when crossing each principal meridian of longitude in the oceanic airspace (i.e., 50, 40, 30 and 20 degrees West longitudes) and the easterly oceanic boundary (i.e., 15, 10 or 8 degrees West longitudes) (ref. 13). Each track published in the OTS track message begins and ends at the navigational fixes that define the coast-out and coast-in points and is defined by a series of track segments joining significant points between the coast-out and coast-in fixes. The significant points as a rule coincide with the position reporting points (ref. 10).

Typically, the eastbound OTS will include 4 to 6 tracks whereas the westbound OTS will include 10 to 12 tracks. The westbound OTS requires more tracks than the eastbound one in order to accommodate the more laterally spread routings from Europe and the Middle East which are attempting to avoid the winds of significant velocity and to accommodate the slower westbound ground speed.

Letter identifiers are used to designate each track, with the letters "A" to "M", excluding "I", assigned to the westbound OTS and "N" to "Z", excluding "O", assigned to the eastbound OTS. Track "A" is the most northerly track and "Z" is the most southerly track, with the lettering in all cases progressing from north to south (ref. 10).

Flight level assignments on each track are based on the traffic activity expected in each direction. Within each eastbound OTS, 16 to 20 flight paths normally are reserved for the major traffic flow direction (i.e., at least 16 eastbound flight level and track combinations at night) and 3 to 4 flight paths are reserved for the opposing flow (ref. 10). On the westbound OTS, a minimum of 16 flight paths are reserved for the main westbound traffic flow and 4 for the opposite direction paths (ref. 15). At least one flight level is left open for use in either flight direction on the most southerly track. Such flight levels are not preassigned a fixed flight direction and are used as the need arises to accommodate traffic approaching or departing the OTS to or from southern locations. Similar open flight levels may be provided on internal tracks and the northerly track (ref. 10).

The odd flight levels are used during the 2 hr transition periods. For example, FL330 and FL370 would be eastbound and FL310 and FL350 would be westbound during the transition from the eastbound to westbound OTS (0800-1000 GMT) (ref. 12).

All OTS flight paths are contained in the FL310 to FL370 range inclusively, and aircraft outside the OTS airspace fly on random routes. However, aircraft may fly above or below the OTS airspace on tracks coincidental with the organized tracks (ref. 10).

Either the Gander ACC or Shanwick OACC, depending on which unit is leading the OTS planning effort, prepares an initial OTS design based on the information available at that facility and then coordinates with the other unit to finalize the OTS. Coordinations are carried out with the New York, Reykjavik or Santa Maria OACCs when any planned OTS track is located in the units of these CTA/FIRs (ref. 10).

Consultations are conducted with adjacent domestic ATS units to establish the preferred domestic routing that joins the OTS tracks. The domestic routings define the preferred path between selected inland fixes and specific coast-in or coast-out fixes. The domestic routings for North America are based on a published listing of North American Routes (NARs) that conform to the overall domestic jetway network, and the European routes similarly conform to the established domestic network. The formally published NARs normally terminate at an inland navigation fix, and the OTS planners determine the final connecting route segment from the inland fix to the coast-in or coast-out fix. The domestic routings selected for each OTS track are included in the track message.

5.3 OTS Establishment Procedures

The Gander and Shanwick OTS planners design each track system to conform as best as possible with the minimum time tracks (MTTs) between the most active North American and European origins and destinations. While both Gander and Shanwick planners use weather forecast data for the 250 mbar level (which corresponds approximately to FL340) and preliminary routing preferences submitted by some airlines, the two facilities apply different techniques in designing an OTS. The Gander planners rely heavily on a special purpose computer program to identify preliminary MTTs which are modified to reflect operational considerations. The Shanwick OTS planners use manual analysis of airline preliminary routing preferences to guide OTS design. The two techniques are described separately in the following paragraphs.

5.3.1 Gander ACC--OTS Establishment Procedures

The calculation of MTTs is a function performed by the Gander Automated Air Traffic System (GAATS), which is a computerized data processing system describing turbojet air traffic at and above FL270 (ref. 10). The GAATS processes weather forecast data provided twice daily by the U.S. National Weather Service (NWS) in Suitland, Maryland.

The weather data describes wind speed, direction, and temperature for various pressure levels and the tropopause height forecasts at grid points covering the NAT and adjacent regions (ref. 10). Each forecast includes four weather projections describing conditions at 6 hr intervals beginning at 0600 GMT or 1800 GMT. A specially designed GAATS program identifies the eight MTTs associated with flights flying at Mach 0.82 from New York and Montreal to London and Santiago, Spain, and in the return direction at 2300 GMT (ref. 10).

The Gander OTS planner uses the MTTs and a 250 mbar weather prognosis chart as the basis for developing the day's track structure. The planner also receives preferred track messages from airlines over the AFTN. The messages describe the tracks desired between selected North American and European airports and calculated by various airlines assuming no constraints on OTS alignment. The airline preferred tracks represent a more diverse pattern of origin and destination pairs than those addressed by the GAATS program. The flight pattern diversity is taken into account by the Gander OTS planners, who also consider such factors and anticipated traffic activity levels, forecasts of significant weather such as clear air turbulence, airspace reservations and related special conditions and contingencies (ref. 10). The planner identifies a few MTTs of importance based on the assembled information and constructs an organized track and flight level structure based on these MTTs.

5.3.2 Shanwick OACC--OTS Establishment Procedures

The Shanwick OTS planners receive the 250 mbar prognostic charts issued by the Bracknell Meteorological Office, UK, and graphically evaluate the westbound MTT situation and manually plot an MTT from London to New York. The prognostic chart analysis is useful as a basis for understanding the prevailing meteorological conditions, but the actual development of the westbound OTS is based on the preferred track messages received from airlines. The OTS planners manually plot each individual track preference on an aeronautical chart covering the NAT CTA/FIRs and study the pattern of the preferred tracks crossing each principal meridian of longitude. The OTS planners manually draw baseline OTS tracks corresponding to a weighted average of the preferred tracks and then lay out OTS tracks that are offset from the baseline tracks.

5.4 OTS Establishment Practices

Several special situations are encountered in planning an OTS which determine the alignment of the tracks as discussed in the following paragraphs.

5.4.1 OTS Placement

The OTS experiences major placement variations because of the changing wind patterns and intensities. Although more complex alignments are often experienced, the following three westbound track systems may be considered typical (ref. 15):

- (1) The north-about OTS system
- (2) The great circle OTS system
- (3) The south-about OTS system.

The three track systems are illustrated in Figures 10, 11, and 12.

The north-about system places the westbound tracks to the north of the jet stream and occurs when high intensity winds flow over U.S. midwestern states, Newfoundland, and across the NAT south of the 53 degree North latitude. The majority of the westbound tracks enters the Shanwick CTA/FIR north of Ireland and exits the Gander FIR north of Newfoundland. Flights to the West Coast of the United States may be forced to the north of the Shanwick CTA/FIR. In the extreme north-about case, the opposing flow eastbound tracks follow the jet stream well to the south of the main flow westbound tracks, and little difficulty is experienced in reserving an adequate number of flight levels for both directions of flight (ref 15).

The great-circle system places the westbound tracks in close conformance with the shortest geographic routes between European and North American airports, and occurs when winds are light or when the significant winds curve perpendicular to the shortest routes. In this case, the MTT generally corresponds to the shortest route. The main westbound and eastbound tracks join points in the British Isles and Newfoundland. The eastbound preferred tracks are aligned to take advantage of the prevailing winds, but, because of the low intensity of the winds, the westbound preferred tracks are in close proximity to or coincidental with the opposing direction tracks. Therefore, opposite direction aircraft are competing for the same tracks and negotiations between Shanwick and Gander OTS planners are required to determine satisfactory assignments of flight directions and levels (ref 15).

The south-about system places the westbound tracks to the south of the significant winds and occurs when the high intensity winds are located in the latitudes north of Newfoundland. The majority of the westbound tracks enter the Shanwick CTA/FIR south of Ireland and exit the Gander CTA/FIR at or south of Newfoundland, with some tracks crossing the Santa Maria and New York CTA/FIRs. In the extreme south-about case, the opposing flow eastbound tracks follow the jet stream well to the north of the main flow westbound tracks, and conflicts between opposing direction flight-level preferences are

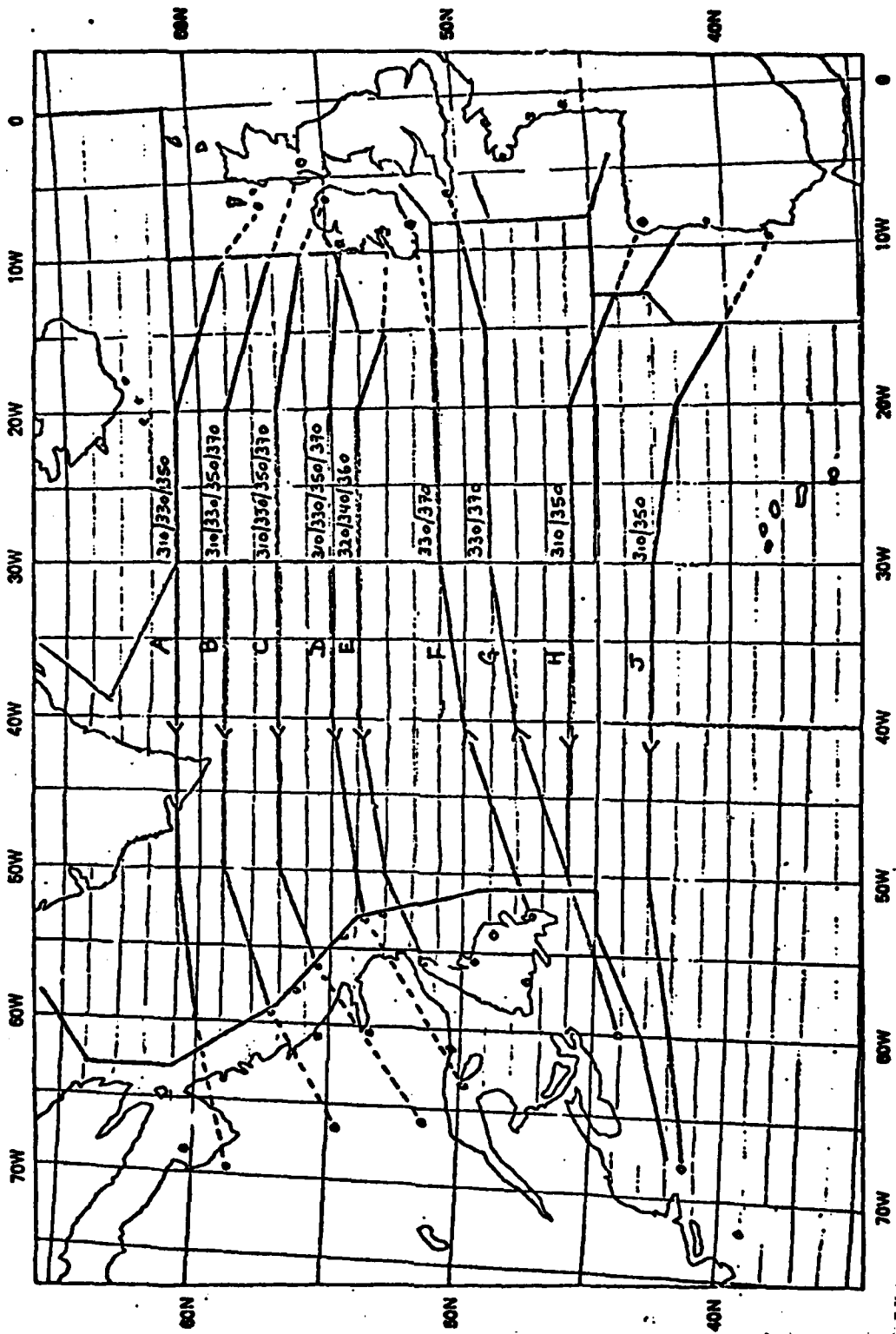

Source: Ref. 15

FIGURE 10 WESTBOUND NORTH-ABOUT OTS EXAMPLE

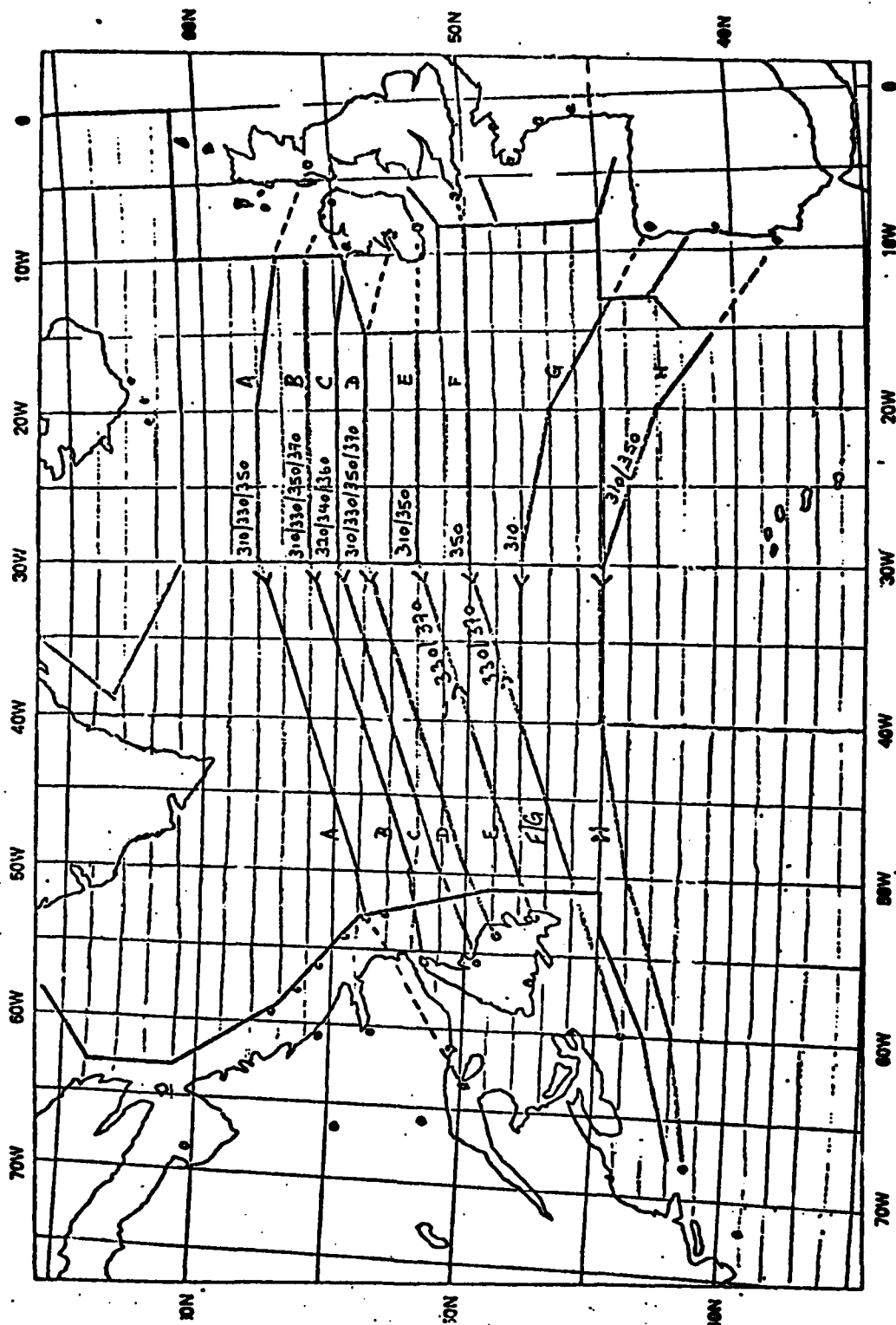

Source: Ref. 15

FIGURE 11 WESTBOUND GREAT-CIRCLE OTS EXAMPLE

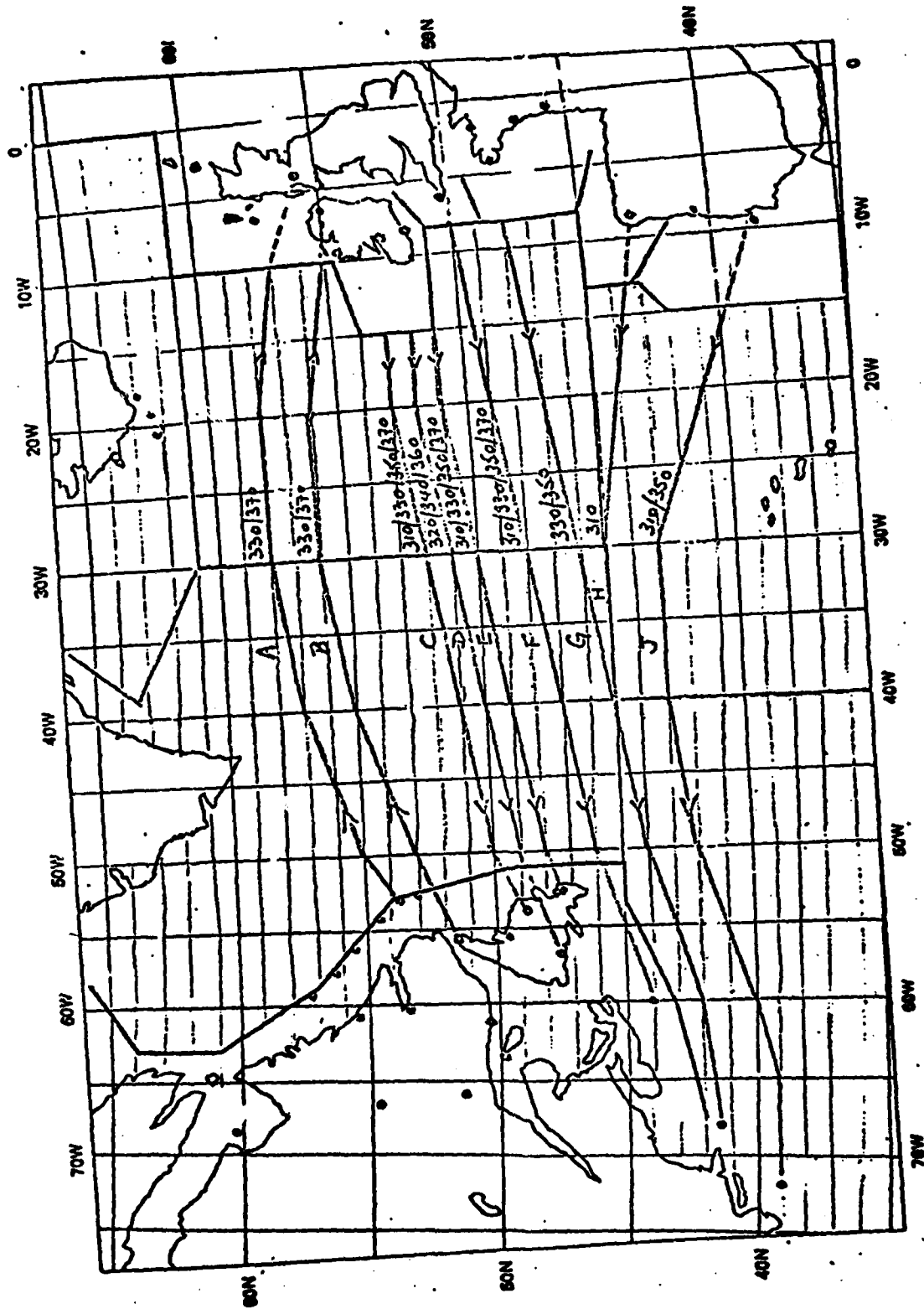

Source: Ref. 15

FIGURE 12 WESTBOUND SOUTH-ABOUT GTS EXAMPLE

limited. However, the south-about OTS planning is complicated by the need for coordination between four ATS units--Shanwick OACC, Gander ACC, New York ACC, and Santa Maria ACC--rather than just Shanwick and Gander and by the convergence of the Iberian tracks into the midst of the main flow tracks (ref. 15).

The placement of the OTS for the eastbound flow is not as variable as that for the westbound flow because the location of the significant winds generally causes the eastbound tracks to converge in the general vicinity of the British Isles. In winds corresponding to the south-about situations, the eastbound tracks are forced north and result in a concentration of track terminations in the Scottish domestic airspace. In the cases of winds corresponding to the north-about and great-circle situations, the terminations of the eastbound tracks are more widely distributed than in the south-about case (ref. 15).

5.4.2 Composite Track Placement Practices

Oceanic off-shore boundary waypoints, for the purposes of this report, are fixes located at the boundary between oceanic and domestic airspaces and define the start and end points of the part of each track that is contained in an oceanic CTA or FIR. (Note that such waypoints may coincide with fishpoints, which is a term associated with coastal defense zone checkpoint operations.) The Gander ACC and Shanwick OACC structure each OTS such that the oceanic boundary entry waypoints of the tracks using composite separation are under radar coverage. Therefore, the use of composite separation on tracks in the northerly oceanic airspace is bounded by the limitations of current radar coverage. Even-level composite tracks are not placed in the airspace to the north of the radar coverage, although standard tracks (i.e., tracks with odd flight levels and 120 nmi. lateral separations) may be used.

As shown in Figure 13, the northern bound of the composite tracks crossing into the Shanwick CTA/FIR is defined by the intersection of the 60 degree North latitude and the oceanic airspace boundary. This bound permits placement of the oceanic off-shore boundary waypoint of the most northerly odd-level outer composite track at 60 degrees North, 10 degrees West, and that of the most northerly even-level track at 59 degrees North, 10 degrees West (ref. 12). Use of composite separation between tracks crossing into the Gander CTA/FIR is limited to the oceanic boundary offshore waypoints south of and including the PORGY waypoint (56:19 degrees North, 58:05 degrees West) shown in Figure 13.

The composite separation airspace on the European side of the Shanwick CTA/FIR is bounded to the south, but not because of radar coverage limitations. The oceanic boundary waypoint of the most southerly odd-level outer composite track is at 49 degrees North, 8 degrees West and that of the most southerly even-level track is at 50 degrees North, 8 degrees West (ref. 12). Composite separations are not applied further south because of complications involving the use of

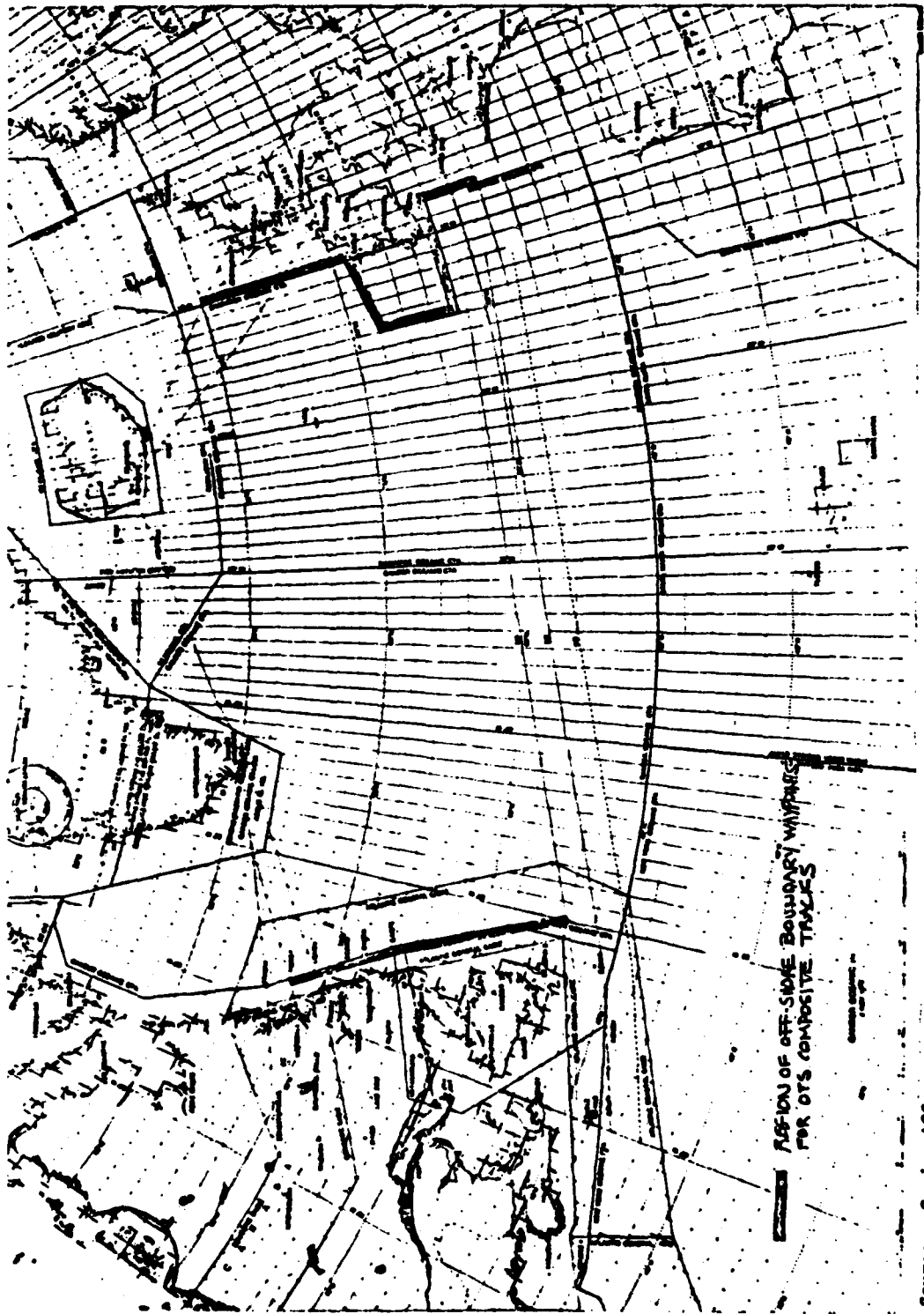

FIGURE 13 OTS COMPOSITE TRACK LIMITS

SOURCE: GANDER ACC

France's military reserved airspace. Although such airspace may selectively be released for civilian use, the use of even-level altitudes is not permitted in the military reservation area; therefore, composite vertical separation is prohibited. Standard tracks may be placed through the reserved airspace when available.

The Shanwick and Gander OTS planners, as a rule, do not apply composite separation on tracks passing into the New York and Santa Maria CTA/FIRs. Therefore, the southern bound on the composite separation airspace on the North American side of the NAT is defined by the southerly limit of the radar coverage serving the Gander CTA/FIR boundary. The corresponding oceanic boundary waypoint for the most southerly outer composite track is at 47 degrees North, 50 degrees West, as shown in Figure 13. Standard OTS tracks are placed in the New York CTA/FIR when called for by traffic and meteorological conditions.

6.0 OPERATING PROCEDURES

6.1 Flight Planning

In addition to the preliminary preferred track analysis provided by some airlines, actual flight plans are developed by all aircraft operators and submitted to ATS units. Submittal of these flight plans is required at least 30 min before departure; however, these plans often are filed one to two hours before estimated departure time (EDT). An airline flight plan is based on a computerized analysis of en route meteorological forecasts, aircraft flight performance characteristics, route requirements, reserve fuel requirements between origin and destination airports, and aircraft estimated weight. Meteorological forecast data describe wind, temperature, and tropopause height for grid points spaced at intervals of 2.5 degrees in latitude and 10 degrees in longitude. The data describes weather at various altitudes, usually including at least the 400, 300, 250, 200, and 150 mbar pressure levels. Flight performance data describe fuel flow rates by speed and altitude and the altitude limits by weight and temperature for the aircraft type being flown. Route data describe the domestic transition routes and the OTS planned to be in effect during the scheduled time of flight as well as the standard domestic route system.

The flight planning computer programs evaluate the data compiled for an individual flight and determine the preferred tracks and flight levels and associated fuel requirements between the origin and destination airports. The flight planning programs may be designed to achieve one of several objectives which include minimizing fuel burn, minimizing flight time or minimizing flight costs, including fuel, crew and maintenance costs. However, due to the overriding influence of fuel costs on direct operating costs, most airlines currently plan flights with the objective of minimizing fuel consumption.

The final flight plan typically is calculated 1.5 to 4 hr before EDT using payload estimates, reserve fuel requirements, OTS data from the most recent track message, and the most recent weather forecast. The reserve fuel is based on en route reserve fuel requirements (which depend on flight time), alternate destination reserve fuel requirements (which are determined by the distance from the planned destination to the nearest alternate airport with suitable visibility forecasts), and contingency/holding reserve fuel requirements. For example, U.S. Federal Aviation Regulations (FARs) require U.S. registered aircraft and aircraft operating into and out of the United States to carry reserve fuel for the alternate destination (which allows for descent to the originally planned destination, climb to cruise, and cruise and descent to the alternate), plus reserve fuel corresponding to 10 percent of the en route cruise flight time, plus reserve fuel for 30 min holding.

In cases where the actual planned takeoff weight varies significantly from earlier estimates, the flight plan must be recalculated by company regulation. In some airlines, the recalculation is left to the discretion of the dispatcher. The actual exact payload is not known until takeoff because the final passenger count is not known. The actual fuel load, which is subject to pilot discretion, may not coincide with that specified by the dispatcher. The pilot may decide to carry extra fuel based on a review of weather conditions and ATS advisories, expectation of diversion from the planned route, and company policy. The pilot may feel, as a result of experience, that the possibility of executing a computer planned step climb is very remote in which case the pilot would request additional fuel for the continuance of flight at the lower level. In some airlines, the computer flight plan analysis may be based on the lower flight level flight. (Note that the most economical altitude flown by a turbojet aircraft generally would be at or just below the highest one attainable under a given loading, with the higher altitudes attainable under lighter loadings.)

Military and general aviation aircraft operators also file flight plans, but do not submit preferred OTS track messages.

6.2 Domestic Airspace Operations

Aircraft operators file their flight plans with the local ATS units providing airport departure services. In the case of international flights, the flight plans are forwarded to all ATS units along the route of flight. Typically an aircraft operator files the flight plan by teletype using the AFTN and addresses the message to the appropriate ATS units. In the case of some airline flights, the flight plan filing may be an update of data for repetitive flights stored in a computer file. In certain situations--as in the cases of the U.S. domestic ATC flight data processing (FDP) system--flight data may be forwarded from the ATS unit receiving the original filing to other ATS units of the same provider authority by means of a special computerized data link network. Flight plan data also is transferred between the Gander ACC and Shanwick OACC by means of computer data link. The flight plan data is used by the receiving ATS units to approve and clear the flight from departure and along the route.

A local ATS unit issues departure clearances to each flight. The unit checks the filed flight plan, amends it if necessary, and provides the clearance describing the route of flight to the destination airport. The pilots accept the clearances with the understanding that the approved routings represent current plans, that subsequent clearance changes may be required, and that a specific oceanic clearance will be issued before entering the oceanic airspace. The clearances are read verbatim (or receive a "cleared as filed" message) to the pilot by a controller before takeoff. When an aircraft actually takes off, a departure message reporting the takeoff time is forwarded to adjacent ATS units along the route of flight. Although not common in oceanic operations, flight plans may be submitted and route clearances issued by air-ground voice communications after takeoff.

A departing flight proceeds along the domestic airways route in accordance with the departure clearance except in cases where circumstance--such as adverse weather, potential conflicts, traffic congestion, radionavigation aid outages, and the like--require revisions. Each ATS sector receives flight plan data in advance of the aircraft's arrival and updates and forwards the aircraft's current flight data to downstream sectors as appropriate.

6.3 Oceanic Entry Operations

The detailed procedures for transitioning aircraft from domestic to oceanic environments vary from center to center but have the common objective of establishing each aircraft on a requested track and flight level subject to the operational constraints imposed by the oceanic separation minima. Further insights into the transition operations may be obtained by separate examinations of the OTS and non-OTS planning procedures as presented in the following paragraphs.

6.3.1 OTS Entry Clearance

Recall that the Shanwick OACC and the Gander, New York and Santa Maria ACCs provide clearances to aircraft entering OTS tracks anchored in their respective CTA/FIR's. The Shanwick OACC determines the entry clearances for all westbound OTS tracks except for any track that may be anchored in Portugal and does not pass through the Shanwick CTA/FIR. The Santa Maria ACC has jurisdiction over the latter case.

Flight plan data normally is sent to an ATS unit coincidentally with the flight plan filing which would have occurred several hours before departure time. The flight plan data are entered into the facility's data processing system which produces flight progress strips. The strips are printed and delivered to the planning or oceanic sector controller position on receipt of an airport departure message or at the time an aircraft is estimated to cross a prespecified en route fix. The flight strip data would include any flight plan revisions made after take-off.

The planner or oceanic sector controller uses the flight progress strip time estimates to assess separations and determine oceanic clearances. The clearance may involve a diversion or delay and may require application of a vertical altitude change, a time delay, a lateral diversion, a speed change or a combination of the above. A partial list of diversion and delay options in order of decreasing preference is shown in Table 3. With reference to Table 3, an altitude increase normally results in improved fuel efficiency, is simple to apply, and, therefore, is the first preference; however, aircraft often are flying at their optimum fuel burn altitude under given weight circumstances, and immediate altitude climbs may not be feasible. A time delay, generally of less than a few minutes, can be achieved before

TABLE 3

SUGGESTED DIVERSION AND DELAY OPTIONS
TO RESOLVE POTENTIAL CONFLICTS ON OTS *

Priority and Option

1. Climb 2000 feet (+2000)
2. Descend 2000 feet (-2000)
3. Reduce speed by Mach .01 (-M.01)
4. Climb 4000
5. Reroute to adjacent composite track and climb 1000 feet (Adj.comp.+1000)
6. Reroute to adjacent composite track and descend 1000 feet (Adj.comp.-1000)
7. Climb 2000 & -M.01
8. Descend 2000 & -M.01
9. Adj. comp. + 3000
10. Lose up to 2 min. (by ocean entry point)
11. Adj. comp. + 1000 & -M.01
12. Adj. comp. - 1000 & -M.01
13. Adj. comp. + 3000
14. Reroute to adjacent standard track at same flight level (Adj.std.)
15. Adj. std. & climb 2000
16. Adj. std. & descend 2000
17. Adj. std. & -M.01
18. Adj. std. & climb 2000 & -M.01
19. Adj. comp. + 3000 & -M.01
20. Adj. std. & descend & -M.01
21. Climb 2000 & lose 2 min.
22. Descend 2000 & lose 2 min.
23. Lose 2 min. & -M.01
24. Climb 2000 & lose 2 min. & -M.01
25. Descend 2000 & lose 2 min. & -M.01
26. Climb 4000 & -M.01
27. Adj. comp. - 3000
28. Descend 4000
29. Climb 4000 & lose 2 min.
30. Climb 4000 & lose 2 min. & -M.01
31. Increase speed by Mach .01 (+M.01)
32. Hold 6 min.
33. Descend 6000

Note: Before checking beyond option #15, check other aircraft
down to option #8.

* Provided by Gander ACC.

oceanic entry by vectoring an aircraft under radar coverage or by issuing time restrictions to pilots such as "lose time to cross intersection not before...hours," and thereby allow the pilot a degree of discretion in accomplishing a time delay. Speed control may also be used as a means to achieve delay. Lateral diversions are achieved by clearing aircraft under radar coverage to the appropriate coast-out fix. Holding is considered to be a last resort if the other techniques are not feasible.

The planner or oceanic sector controller passes each oceanic clearance to the clearance delivery and to the domestic en route sector positions (which could include sectors at other ATS units as in the case of the Shanwick and Gander planners). At Gander, the clearance delivery frequency is active only during busy traffic periods each day. In cases where the clearance delivery position is not active or is outside the air-ground radio range of aircraft, a domestic en route sector issues the specific oceanic clearance to the aircraft. The clearance often is issued 30 to 45 min before an aircraft enters oceanic airspace, and involves the reading verbatim by the controller of the aircraft's approved routing. The aircraft pilot may negotiate the clearance if it is not acceptable, in which case the clearance delivery is coordinated with the planner.

Westbound flights approaching the Shanwick CTA/FIR from European origination points usually are issued oceanic clearances while in flight east of the 2 degrees West longitude. In the case of aircraft departing from airports such as at Prestwick, Scotland, and Shannon, Ireland, which are near to oceanic airspace, the specific oceanic clearances are included as part of the routine departure clearance issued before takeoff. Some westbound flights approaching oceanic airspace south of 48 degrees North may not be within VHF range of a clearance delivery service and must request oceanic clearance from Shanwick by relay through the Shannon COM station HF radio operator.

Regardless of the mode of clearance delivery, the domestic en route sectors are responsible for ensuring that the clearances are carried out for each aircraft under their control before entering oceanic airspace. In the event an aircraft is not within 3 minutes of the oceanic entry time estimate (as shown on the flight strip and previously used by the planner in determining clearance), the domestic sector controller advises the planner or oceanic sector controller of the discrepancy so that a new oceanic clearance may be determined if necessary.

6.3.2 Non-OTS Entry Clearance.

The determination of oceanic clearances for flights entering random tracks and ATS routes differs somewhat from that of OTS tracks. For example, the non-OTS track diversion and delay strategies are not quite the same as those employed to resolve OTS potential conflicts because

composite separations are not used on the non-OTS tracks. A partial list of diversion and delay options in order of decreasing preference provided by the Gander ACC is shown in Table 4 for illustrative purposes.

Although the ATS units may issue CTA/FIR-wide conflict-free clearances, the clearances issued by the Shanwick OACC and Gander ACC (and likely by the Santa Maria and Reykjavik ACCs) may differ from those issued by the New York, San Juan and Miami ATS units. The Shanwick and Gander ATS units issue clearances that would require conflict resolution maneuvers by aircraft before entering the CTA/FIR. The New York, San Juan and Miami ACCs may issue clearances that would allow aircraft to continue on course and to carry out the maneuvers at some later time in accordance with the controller's oceanic entry clearance instructions; this practice is understood to be routine at the New York, San Juan and Miami ACCs.

For example, consider the case of two crossing random track flights at the same altitude in conflict with each other. The Shanwick OACC or Gander ACC planner assesses the situation before the aircraft (or at least before the second aircraft) enters the CTA/FIR and issues clearance instructions to the appropriate adjacent oceanic sector (if the aircraft is inbound from another oceanic CTA/FIR), domestic sector, or clearance delivery position. The clearance instructions then are relayed to one or both aircraft before entry into the Gander or Shanwick CTA/FIR. The clearance will require the aircraft to effect the resolution action--such as an altitude change, a track change or a delay maneuver--at or before entry into the Gander or Shanwick CTA/FIR.

A clearance issued by the New York, San Juan and Miami ATS units would be transmitted as described above and would be delivered to the pilot before the aircraft proceeds through the CTA/FIR. The clearance could allow the aircraft to maintain its current altitude and track at CTA/FIR entry, but could include a restriction on the conduct of the flight at a downstream position. Such a restriction typically would require the aircraft to cross a specified fix at a given altitude or to adhere to a fix crossing time constraint. An altitude change clearance, for example, conceivably could allow crossing flights to converge to near the 20 min separation minima before an altitude change maneuver is carried out; the altitude change must be completed before a 20 min closure between aircraft occurs. Similarly, a time restriction conceivably could allow the two aircraft to cross at the same altitude with a 20 min (at least) longitudinal separation. In the case of crossing traffic, the longitudinal separation is critical rather than the 90 nmi or 120 nmi lateral separation, and altitude changes are usually used to resolve conflicts.

6.4 Oceanic Airspace Operations

Control jurisdiction over an aircraft is transferred from a domestic to an oceanic en route sector controller when the aircraft enters oceanic airspace. Given that oceanic clearances have been issued and that proper oceanic flight paths have been established before the time

TABLE 4

SUGGESTED DIVERSION AND DELAY OPTIONS
TO RESOLVE POTENTIAL CONFLICTS BETWEEN NON-OTS TRACK TRAFFIC*

Priority and Option

1. Climb 2000 feet
2. Descend 2000 feet
3. -M.01
4. Climb 4000 feet
5. Climb 2000 & reduce speed by Mach .01 (-M.01)
6. Descend 2000 & -M.01
7. Reroute 60 NM laterally (to gain 120 NM lateral separation)
8. Climb 2000 & reroute 60 NM
9. Lose 2 min. (before ocean entry point)
10. Reroute 60 NM & -M.01
11. Climb 2000 & reroute 60 NM & -M.01
12. Descend 2000 & reroute 60 NM
13. Climb 2000 & lose 2 min.
14. Lose 2 min. & -M.01
15. Climb 2000 & lose 2 min. & -M.01
16. Climb 4000 & -M.01
17. Descend 2000 & lose 2 min.
18. Climb 4000 & reroute 60 NM
19. Descend 4000
20. Reroute 120 NM
21. Climb 4000 & lose 2 min.
22. Climb 2000 & reroute 120 NM
23. Reroute 120 NM & -M.01
24. Descend 4000 & reroute 60 NM
25. Climb 4000 & lose 2 min. & -M.01
26. Climb 2000 & reroute 120 NM & -M.01
27. Increase speed by Mach .01 (+M.01)
28. Hold 6 min.
29. Descend 6000

Note: Before checking beyond option #16, check other aircraft
down to option #7.

* Provided by Gander ACC.

of crossing an off-shore boundary waypoint, the oceanic controllers' main responsibilities are the maintenance of separations in their CTA/FIR and the provision of separation for aircraft entering adjacent airspace.

6.4.1 Communications Procedures

By the time of oceanic entry, an aircraft would have been instructed by the last domestic sector controller to change air-ground radio frequency and contact the appropriate COM station--either a civilian or a military communications center. The NAT oceanic air-ground communications generally are by HF transmissions, but extended range VHF is provided by the Gander and Shannon COM stations. The 50 degree West (Gander) and the 10 degree West (Shannon) longitude position reports on the OTS normally are transmitted by extended range VHF while all other OTS position reports normally are by HF.

The position reports may be given in the form of AIREPS which, as prescribed by ICAO (ref. 2), include: (1) current and next position information (i.e., aircraft identification, position, time, flight level or altitude, and next position and associated time estimate); (2) operational information (i.e., estimated arrival time, endurance and other company-oriented data); and (3) meteorological information (i.e., air temperature, wind, turbulence, aircraft icing, and supplementary information). The position information is obligatory in each report, and the meteorological information generally is given by each aircraft except on the OTS where the meteorological information is requested only from one of the aircraft entering each flight level on each track each hour.

Position reports are forwarded by teletype from a radio operator to an oceanic sector controller. Pilot messages requiring responses by controllers, such as altitude change requests, may be forwarded by voice interphone and followed by a redundant teletype message. Pilot requests routinely are forwarded by voice from COM stations to ACCs, but teletype routinely is used to transmit messages from the Shannon COM station to the Shanwick OACC.

Controller-to-pilot messages usually are transmitted by voice interphone from the oceanic sector controller to the radio operator for relay to the pilot (except at Shanwick where the message is initiated by teletype rather than voice transmission). Pilot acknowledgment of the controller's message may be relayed to the controller either by teletype or interphone depending on the need for or urgency of further control action.

Selective calling (SELCAL) radio communications systems are carried by aircraft flying in the NAT airspace and enable radio operators to selectively signal a pilot by a tone message when an HF transmission is to be initiated from the ground. This procedure alleviates the pilots

from constantly listening to the sometimes noisy HF channels. Pilots are required to continuously guard (i.e., maintain a listening watch on) the specially designated VHF emergency frequency of 121.5 (MHz) except when communicating on other frequencies. In the event an aircraft loses HF contact with the radio operator, the pilot should relay reports through another COM or ATS center that can be contacted or through another aircraft (ref. 14).

Air-ground voice communications between a pilot and an oceanic sector controller may be established if required in extenuating circumstances through voice switching facilities available at some COM stations. For example, the New York COM center and U.S. military COM centers are capable of establishing phone patches by special telephone and radio connections.

6.4.2 Separation Maintenance Procedures

As part of the separation maintenance responsibilities, the oceanic sector controllers respond to clearance or reclearance requests initiated by aircraft in their CTA/FIR. Normally, such activities involve requests for an altitude change to a higher flight level and occur when aircraft burn off enough fuel to attain a more fuel-efficient altitude. However, requests for track or altitude change may be initiated to avoid severe weather, for emergencies, or to obtain a more efficient route to the destination. Situations infrequently may arise where potential violations to separation standards require conflict resolution action by the oceanic sector controller. Differences between actual and forecast winds or flights flying faster or slower than originally cleared may on rare occasion cause projected conflicts at oceanic entry points or at downstream points along the track. The options used by controllers to resolve the conflict may involve altitude, speed or track changes, and are similar to those used to develop the oceanic entry clearances for the OTS and non-OTS tracks (see Tables 3 and 4).

The clearance revisions, whether for an altitude change request or a potential conflict resolution, are recorded on flight strips. At the Gander ACC, the revisions are entered into the computer data file system to maintain the currency of GAATS.

6.4.3 Coordination Procedures

The data link between the GAATS and the Shanwick computer is used to forward flight data for aircraft in OTS airspace and eliminates the need for oceanic sector controllers of the two facilities to coordinate by interphone in regard to the routine movement of OTS traffic from one CTA/FIR to the other. Flight data, including boundary crossing time estimates, are automatically forwarded for aircraft estimated to cross 30 degrees West between 61 degrees North and 45 degrees North, at an altitude between FL270 and FL490, and at a speed between Mach 0.70 and Mach 0.87. Flight data is automatically forwarded, based on data scans

made at 5 min intervals, to the Shanwick OACC when eastbound aircraft approach 40 degrees West longitude and is forwarded to the Gander ACC when westbound flights approach the 20 degrees West longitude. The forwarding of the flight data enables the delivery of flight progress strips to the oceanic sector controllers prior to the arrival of the aircraft at the 30 degree West longitudinal boundary between the two CTA/FIRs. Transfer of control is assumed at the 30 degree West longitude and formal handoffs between the Shanwick OACC and the Gander ACC for OTS aircraft routinely are not required.

In regard to aircraft not in OTS airspace, the oceanic sector controller initiates coordination of the movement of aircraft into a downstream oceanic sector by passing boundary crossing time estimates and pertinent flight data to the adjacent controller. Typically the flight information is passed by interphone 45 to 90 min before estimated boundary crossing, and the aircraft's clearance is negotiated at the time of data transfer.

Interfacility or intersector coordination also is required when an aircraft passes close by an oceanic boundary without crossing that boundary (e.g., within 60 nmi of an adjacent CTA/FIR). The adjacent CTA/FIR controller must be advised of the presence of the aircraft so that separation may be provided between that aircraft and any aircraft in the adjacent airspace.

6.5 Oceanic Exit Operations

Aircraft exiting oceanic airspace into domestic airspace are instructed by radio operators to change air-ground frequency and establish VHF contact with domestic sector controllers. While oceanic sector controllers are not directly involved in the transition to domestic airspace, the oceanic controllers are required to provide proper oceanic separations to the coast-in fix. In most domestic areas adjacent to the NAT oceanic airspace, aircraft enter radar coverage while approaching landfall, and maneuvers to establish radar separation are initiated by domestic sector controllers before the aircraft reach the coast-in fix. In areas like Northern Canada, where radar coverage is not available, nonradar domestic separation rules are applied as determined by the capabilities of the local radionavigation aids.

OTS exit procedures typically do not involve diversion or delay operations but are of interest because special precautions need to be made in effecting the transition from oceanic to domestic airspace. The OTS composite procedures allow 1,000 ft vertical separation between flight levels on adjacent tracks while domestic routes use 2000 feet spacings. Also, the direction of flight on each OTS flight level is selectively assigned while domestic operations may apply hemispheric separations; for example, FL280, 310, 350, and 390 would be reserved for westbound traffic. Therefore, domestic flight levels often are not compatible with the OTS levels and aircraft exiting oceanic airspace need to be transitioned onto domestic levels of the appropriate direction of flight.

6.6 Supersonic Transport Operations

The two published fixed tracks serving SSTs flying in the FL450 to FL600 altitude range on the New York/Washington and London/Paris routes are set 60 nmi apart and cross the Shanwick, Gander and New York CTA/FIRs. The tracks are designated "SM" and "SN" as shown in Figure 4. The northern SM track is westbound and the SN track is eastbound. A third track, "SO", which is south of and parallel to SN, is an off-loading track, and cannot be published or used for flight planning purposes. The SST oceanic flights do not conflict with the lower level subsonic flights and rarely conflict with each other because of the low frequency of daily SST movements. The SSTs are quite sensitive to optimum fuel consumption profiles because of range limitations. As a result, the SSTs are allowed to conduct cruise climb operations on the fixed tracks and do not require significant planning activities by the oceanic ATS units (ref. 10).

Oceanic control operations for SSTs are similar to those applied to subsonic flights. The SSTs: (1) file flight plans and are issued oceanic clearances to effect cruise climb to optimum altitude, (2) give position reports which are relayed to the oceanic sector controllers who also are monitoring subsonic flights, (3) are provided separation services based on flight progress strip updates, and (4) request and receive descent clearances. Oceanic clearance revisions to resolve conflicts are seldom required (ref. 10).

Computer data processing for the SSTs is restricted to flight strip production functions. Computer data link services between Shanwick and Gander and conflict prediction capabilities are not applied to SST flights because of limitations in data processing capacity. Voice interphone procedures are used to pass flight data between facilities (ref. 10).

6.7 Low Level Oceanic Operations

Nonturbojet aircraft operating in NAT oceanic airspace between FL60 and FL260, and sometimes up to FL290, are handled by the ATS units. The low level aircraft, which range in type from single-engine piston to four-engine turboprop have operating attributes that vary in terms of their speed and cruising altitude characteristics, the sophistication of on-board communications and navigation equipment, and the experience and proficiency of their pilots. Military operations are a significant part of this flight population, whereas some other flights are ferry operations conducted to deliver general aviation aircraft to transoceanic destinations. Also, some flights are scheduled or chartered passenger operations (ref. 10).

Numerous low level operations are conducted in the northerly NAT airspaces between Canada, Greenland, Iceland, and Northern Europe where VHF air-ground communications may be used during segments of the flight; elsewhere HF air-ground communications are used. Because of their slow speeds, relative to turbojet aircraft, and because of the ICAO requirements to report positions at hourly intervals if possible, position reports are given at intervals of 5 degrees or less.

Oceanic sector controllers follow each flight on flight progress strips and provide the same separation services provided to high level flights. At the Gander ACC, flight plan data processing and flight progress strip production are performed manually rather than by computerized procedures, and, as in the case of SSTs, computer data link service and conflict prediction are not applied (ref. 10).

6.8 Current Plans for Improvement

Improvement plans in effect at the ATS units serving the NAT region largely are near term in nature and address procedural rule changes and computer-based equipment improvements expected in the early 1980s. The primary procedural changes are the establishment of a standard 60 nmi lateral separation minimum in October, 1980, and the establishment of a 10 min longitudinal minimum by 1982, both in the MNPS airspace. Consideration is also being given to expanding the MNPS airspace by moving parts of the eastern MNPS boundary from the 60 degrees West longitude closer to the U.S. coast.

The Gander, New York, Miami and San Juan ACCs and the Shanwick OACC are in various stages of considering or implementing near-term automation plans to upgrade and expand computer data processing and flight data display capabilities.

6.9 Supplemental Operational Information

Selected operational situations are addressed in Appendix K which provides some additional descriptions of ATS capabilities and user requirements.

7.0 ATS COSTS--PRELIMINARY ESTIMATES

Estimates of the annual cost of providing ATS services at the various ATS units is presented in Table 5. These annual operating and maintenance cost estimates for the ATS units are based on data furnished by some of the provider authorities and on assumptions concerning the level of expenditures at sites where cost data were not made available.

The derivation of the cost estimates is described in Appendix L along with the data sources. The staff cost category shown in Table 5 refers to the annual personnel costs associated with ATS. The other direct operating cost category refers to the nonstaff annual expenditures required to maintain ATS, and include such items as parts and supplies, leases, electricity, etc. The indirect cost category includes such items as depreciation, interest payments, and insurance premiums.

The cost estimates shown in each category for the Shanwick OACC are based on data provided by the UK and were adjusted for inflation and the currency exchange rate. The Gander ACC data, as explained in the appendices, are based on the total ATS cost estimates as provided by Canada and are distributed among each expenditure category; it is assumed that the staff, other direct operating, and indirect operating costs of the Gander ACC are proportional to those of the Shanwick OACC. The New York, San Juan and Miami ACC costs are based on estimates of the ATS expenditures allocated to the NAT and do not include certain overhead costs. The Reykjavik cost data are based on estimates provided by Iceland. No cost data were provided for the Santa Maria ACC, and the estimates shown in Table 5 assume that the ATS costs for the Santa Maria ACC are 80% of those for the Reykjavik ACC based on the traffic handled by the two units.

An estimated total annual ATS cost of US\$ 18.1 million (1979 dollars) is shown in Table 5 for the NAT. This cost represents both high and low altitude ATS in the CTA/FIRs addressed because the data obtained from the provider authorities does not distinguish between airspace levels. In order to account for overhead costs not included in the previous cost estimates for the US facilities, the operations and maintenance costs are assumed to be of the order of almost double those estimated and presented in Table 5. This assumption yields an estimate of about US\$ 7 million for US operations and maintenance costs, and raises the estimated total annual ATS costs for the NAT to US\$ 21 million.

Table 5

NAT ATS 1979 ANNUAL COST ESTIMATES

Expenditure	Annual Cost 1979 US\$ (000)						Total†	
	Gander ACC	Shanwick OACC	New York* ACC	Santa Maria ACC	Reykjavik ACC	San Juan* ACC		Miami* ACC
Staff Cost	3486	4191	2700	410	512	708	280	12,287
Other Direct Operating Cost	2072	2491	125	56	70	32	17	4,863
Indirect Operating Cost	336	404	75	47	59	20	10	951
Total	5894	7086	2900	513	641	760	307	18,101

*These cost estimates do not include certain overhead costs, see text.

†These total costs do not reflect certain U.S. facility overhead costs, see note above.

APPENDIX A

GANDER ACC--SUPPLEMENTAL DESCRIPTIVE DATA (Excerpts from a Draft by Transport Canada)

A.1 Information Source

This appendix consists of selected excerpts quoted directly from the draft report "Air Traffic Control on the North Atlantic, the Gander Oceanic Operation" (ref. 10) prepared by Transport Canada and submitted in June 1979. The excerpted material includes ATS system descriptions that supplement the information provided in the main text of this report, and excludes portions of Transport Canada's draft report that are covered in the main text. Parts of this appendix provide additional detail to the main text descriptions and therefore some degree of redundancy exists between the main text and portions of this appendix. The quoted material is indicated by indented text in this appendix.

A.2 Airspace Structure

A.2.1 Airspace Boundaries

Before proceeding with the descriptions developed by Transport Canada, note that Gander ACC's area of jurisdiction as shown in Figure 2 of the main text includes oceanic and domestic airspace; the latter is provided with radar surveillance coverage. The Moncton ACC is responsible for the Canadian domestic airspace adjacent to the Gander ACC's airspace. The Sondrestrom FIC is responsible for the part of the low altitude FIR airspace below FL195 over southern Greenland that is underneath a shelf of high altitude airspace of the Gander oceanic CTA/FIR. Oceanic airspace adjacent to the Gander CTA/FIR includes the New York, Santa Maria, Shanwick and Reykjavik CTA/FIRs.

A.2.2 Oceanic Sectorization

Sectorization of the Gander oceanic CTA/FIR is effected by flight level segregation rather than geographic sub-division of the airspace.

A.3 Facilities

A.3.1 General Accommodations

The Gander Area Control Centre is located on the second floor of the terminal building at the Gander International Airport, of Gander (Newfoundland). Figure A-1 presents a floor plan of the operations room.

1. Flight planning office
2. Flight plan entry room
3. AFTN
4. Flight plan entry devices
5. Supervisors desk
6. Arrival, departure & low level enroute
7. High level domestic
8. Planning Sectors
9. Ocean Sectors
10. (P) strip printer
11. (D) strip printer
12. Programmed keyboard and (A) strip printer
13. Alternate programmed keyboard and (A) strip printer
14. Programmed keyboard and (C) strip printer
15. Clearance delivery sector
16. Estimate copy sectors
17. (O) strip printer
18. Hradio teletype printers

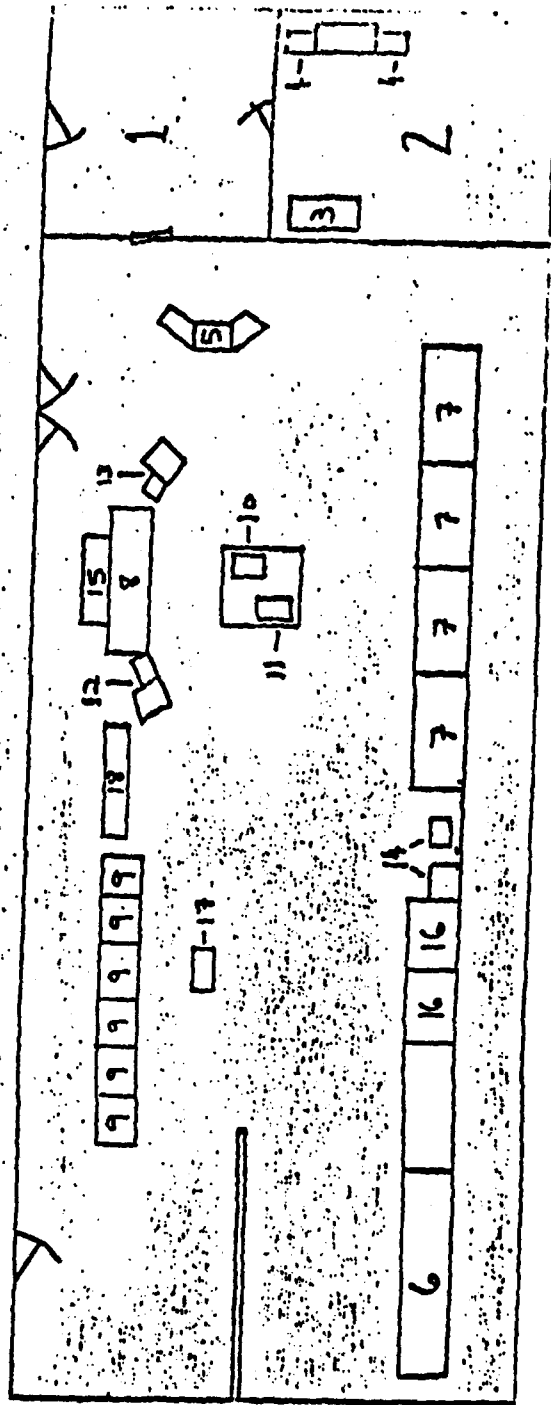

Source: Ref. 10

FIGURE A-1 GANDER ACC OPERATIONS ROOM LAYOUT

A.3.2 Located immediately adjacent to the operations room is the computer equipment room, and in close proximity are the offices of the Chief, the Operations Supervisor, the Data Systems Supervisor, and the administrative and secretarial staff.

A.3.3 In the Spring of 1981, it is expected that operations will be moved to the new Gander Area Control Centre. This recently completed building is located in the town of Gander and will be used solely for the air traffic control operation.

A.3.4 Data Processing

To assist in data acquisition, processing, and transfer, Gander has a computer system known as the GAATS (Gander Automated Air Traffic System), which is designed to handle turbojet traffic at and above flight level 270.

The GAATS performs the following functions:

- (1) Stores flight plan information and North Atlantic tracks.
- (2) Computes fix estimates and prints flight progress strips.
- (3) Performs conflict prediction on eastbound oceanic traffic.
- (4) Produces the required minimum time tracks.
- (5) Transfers flight plan information and control data to the Prestwick area from the Gander area.
- (6) Accepts flight plan information and control data from the Prestwick computer on all flights entering the Gander area from the Shanwick area. This data is processed by the GAATS and presented to the controller on flight progress strips.
- (7) Provides statistical data on all oceanic flights processed.

In order to produce realistic minimum time tracks and fix estimates, the GAATS uses weather forecasts obtained twice daily from the U.S. National Weather Service at Suitland, Maryland. The forecasts cover the entire area which is pertinent to the Gander operation. They are organized in convenient time periods to provide for changing conditions over the short term and to allow outdated information to be dropped or replaced when new weather is added.

Since 1975, the GAATS has been linked with the computer serving Shanwick Control at Prestwick. Data is transferred at a rate of 75 characters per second in a "speech plus duplex" mode via landline and undersea cable.

A.4 Operating Positions

To illustrate how the high level oceanic system works it may be best first to identify the key people in the operation and briefly describe the duties of each.

The Planner--The planner is responsible for the overall organization of the airspace so as to obtain optimum usage from the point of view of both the user and air traffic control. He designs the oceanic tracks and carries out the necessary negotiation and coordination with adjacent units regarding the use of flight levels and the assignment of domestic routings. When the traffic flow begins, his task is to plan separation between individual flights by assigning each a flight profile that is conflict free and as close as possible to the route and altitude requested in the flight plan.

High Domestic Controller--The role of the high domestic controller in the oceanic control operation is mainly to provide a smooth transition from domestic to oceanic separation standards on eastbound traffic, and from oceanic to domestic separation standards on westbound traffic. By direct VHF communication with the pilot and through the use of secondary surveillance radar and/or VOR/DME facilities, he climbs, descends, or re-routes an eastbound aircraft in order to position it on the flight profile designated by the planner, always ensuring that on entry to the ocean, separation exists and mechanisms are in place, such as speed adjustment, to make certain that it is maintained. His task with westbound traffic is to assign each aircraft a flight profile through domestic airspace to destination, and to comply with requests for altitude change to the extent that traffic will permit. In addition, he is responsible for passing the necessary flight information to adjacent domestic units on traffic that will enter their control areas.

Clearance Delivery Position--When the planner has made his decision, the clearance is put in written form and passed to a special "clearance delivery" position or to the appropriate high domestic sector for delivery to the flight when it comes within VHF radio range. The clearance delivery position operates for about 5 hours a day during busy traffic periods; otherwise, the oceanic clearances are delivered from high domestic. Normally, a radio transmitter situated on the west

coast of Newfoundland is used for this purpose, as it permits communication with the aircraft early enough to make clearance changes, if necessary, without causing undue disruption to the overall traffic pattern.

Oceanic Controller--The oceanic controller is responsible for maintaining the separation previously planned by Gander or Shanwick and for finding alternate solutions if the planned separation does not work out. He also must accommodate westbound traffic into the main flow from the New York, Santa Maria and Reykjavik areas, imposing as little penalty as possible. To provide optimum service to the user, in the interests of fuel economy and maximum range, he is required to consider requests for more suitable altitudes or routings, and issue clearances if the traffic situation permits. Under certain circumstances, he may be expected to initiate such action on his own without having received a request from the pilot. He also coordinates with and transfers all pertinent information to adjacent oceanic and domestic control units on flights which will operate in their areas of jurisdiction.

Oceanic Coordinator--The ocean coordinator position operates during the main westbound traffic flow whenever there are two or more ocean sectors. Its primary function is to effect coordination between Gander Oceanic and other air traffic control units, and between the different oceanic sectors in Gander, on matters relating to oceanic traffic. The coordinator is also responsible for copying all estimates that are not normally received on the computer data link and for accommodating this traffic into the main streams.

The Air Traffic Control Assistant--The air traffic control assistant provides support service for the controller in all phases of the oceanic operation. He relays information via teletype to other air traffic control units and aviation agencies and distributes incoming information to the appropriate sectors. He processes flight plans by entering them into the GAATS computer and activating them when appropriate notification is received. He copies control data (estimates) from Moncton Area Control Centre on eastbound traffic and processes it through the computer. (In situations where the computer is unserviceable, the processing of flight plans and estimates is done manually.) Other duties include distributing flight progress strips to the control sectors from the various printers located in the operations room, entering updated clearance information into the computer as a flight progresses, copying westbound estimates from Shanwick and processing them manually when the GAATS is unserviceable, and relaying flight information to air defense units. One assistant per shift is responsible for the day-to-day operation of

the GAATS computer. Duties include obtaining and processing forecast weather data, entering the oceanic tracks, maintaining surveillance of the data link operation, and gathering and processing statistical data.

A.5 Control Responsibilities

Although the Gander Area Control Centre is a combined domestic and oceanic control operation, the controllers (or the assistants) are not confined to one particular work environment. They usually rotate on a shift to shift basis through three of the four different work areas (Low Domestic, High Domestic, Ocean, and Planning). However, before being assigned to the Planner position, a controller must have had a considerable amount of work experience in the High Domestic and Ocean positions.

A.6 Flight Example

To further develop an understanding of the Gander oceanic control operation, a typical (eastbound) flight (is followed) through the system from departure point to destination. The procedures, however, governing a westbound flight are essentially the same, except that the roles played by the service providers on both sides of the Atlantic are reversed.

ABC 100 is a daily jet flight from New York to London, scheduled to depart at 2300 GMT.

For a departure time of 2300 GMT, the operator of ABC 100 would have made up a flight plan, and normally by 2100 GMT it would have been transmitted via teletype to all concerned agencies, including the appropriate air traffic control units. The flight plan would have included such information as the flight identification, type of aircraft, speed, route of flight, requested altitude, departure point and destination, proposed departure time, and estimated times for certain points en route. The requested route of flight would have been decided by two factors: the most economical route as determined by the operator, and the alignment of the North Atlantic Track Structure. (Information on the North Atlantic tracks would have been made available to the operator normally not later than 1400 GMT.) Suppose that he has chosen track X, which is the one most closely aligned with the optimum track for his flight. Track X, on this particular occasion, happens to be: Gander 50 degrees N/50 degrees W 52 degrees N/40 degrees W 53 degrees N/30 degrees W 53 degrees N/20 degrees W 53 degrees N/15 degrees W Shannon.

ABC 100 departs at 2305 GMT, having been cleared by New York Air Traffic Control to the destination airport via the flight planned route to maintain flight level 330, with the understanding that a specific oceanic clearance will be received from Gander at the appropriate time. The flight progresses through the New York area, the Boston area, the Moncton area, and then the Gander (domestic) area, each one in turn having been given the appropriate advance notification. All this time, the aircraft is under constant radar surveillance and is 'handed off' on radar from one unit to the next.

At about the time ABC 100 enters the Gander domestic area, the pilot will contact the Gander clearance delivery sector on VHF radio to obtain the oceanic clearance. Provided that the clearance is acceptable, ABC 100 will now be returned to the appropriate control frequency to await any changes in flight profile that the clearance might have contained. In this case, he has been advised to expect flight level 350 for the crossing. He will be cleared to the new flight level when it is acceptable to him and/or when the traffic situation permits. This will almost always be somewhere within radar coverage, which extends to approximately 200 nautical miles radius of Gander.

When ABC 100 has reached flight level 350 and has passed the last land-based reporting point, but is still within radar coverage, the flight will be told to contact Gander Aeradio. Gander Aeradio is, primarily, an HF radio facility, operated by the Canadian Ministry of Transport, whose main purpose is to act as a communications link between aircraft in the Gander Oceanic Area and service provider on the ground, the chief of these being Gander Oceanic Air Traffic Control.

The initial contact with Gander Aeradio will be on VHF radio. Since the limit of VHF range is normally only about 200 nautical miles, ABC 100 is now assigned a primary and a secondary HF frequency for use outside the VHF coverage limit.

While over the ocean, the flight is required to transmit a position report for each 10 degrees of longitude along the route (e.g., 50 degrees W, 40 degrees W, etc.). The first such report will be at 50 degrees N/50 degrees W. When he passes that point at 0140 GMT, he, therefore, reports it to Gander Aeradio, along with such other pertinent information as the flight level and the estimated time for the next reporting point, 52 degrees N/40 degrees W.

The position report information is used by the Gander oceanic controller as the basis for his control decisions. At this stage of the flight, instead of being shown on radar, ABC 100

is now represented on a little strip of paper about 8 inches long by 1 inch wide. This "flight progress strip" carries all the necessary flight plan and clearance information and it also has space available for entry of the position reports.

When ABC 100 reaches 30 degrees W, he is transferred to the Ballygireen HF radio facility, situated near Shannon, Ireland. This facility performs essentially the same function for the eastern side of the North Atlantic as Gander Aeradio does for the western side. At this time, also, control of the flight is transferred to Shanwick Oceanic Air Traffic Control.

There is an overlap area between 40 degrees W and 20 degrees W where communications from ABC 100 can be read by either Gander Aeradio or Ballygireen. All position reports and other messages transmitted while in this area are received by both Gander and Shanwick air traffic control units. This facilitates coordination between the two centres on control decisions affecting both areas of jurisdiction and it also provides the necessary advance information for routine flight handling. However, in the case of ABC 100, as with all other eastbound flights, all the pertinent flight plan and control data would have been passed from Gander to Shanwick about 30 minutes before the aircraft reached 40 degrees W.

Somewhere in the Shanwick Oceanic Area, it is very likely that ABC 100 will have burned off enough fuel to enable the aircraft to climb to and maintain a higher altitude. It may be more economical now, from the point of view of fuel consumption for the remainder of the flight, to be at flight level 370, rather than flight level 350. If this is the case, a request for flight level 370 will be communicated to Shanwick Control through the radio station at Ballygireen. Shanwick will respond to the request on the basis of current and anticipated traffic, and if ABC 100 can be safely fitted into flight level 370, a clearance to that effect will be issued. This will be passed on to the aircraft by Ballygireen and notification that ABC 100 is maintaining the new altitude will eventually be relayed to Shanwick.

Shortly after passing 15 degrees W, the aircraft will be in range of the Shannon radar, and at approximately the same time, it will be instructed by Ballygireen to contact the Shannon control facility on VHF radio. ABC 100 will now be given an airways clearance to London, which may or may not agree with the routing requested in the flight plan, depending on the traffic situation. Other flights will, at the same time, be feeding into the Shannon area from adjacent tracks to the north and south, and they all must be fitted into a relatively narrow stream for London and other airports on the

European continent. However, from here on, there will be constant radar surveillance, permitting considerably less spacing between aircraft than was the case over the ocean.

From Shannon radar, the flight is handed off to a control facility in the vicinity of London, which now assumes control. ABC 100 will be cleared to commence descent about 20 minutes prior to reaching the destination airport and will arrive in London shortly after 0500 GMT.

A.7 Personnel

A.7.1 Operational Staff

The operational staff at the Gander Area Control Centre is made up of air traffic controllers and their support personnel, the air traffic control assistants. The number on duty at any one time is dependent on anticipated traffic volume, which varies considerably from season to season, day to day, and especially throughout any selected 24-hour period.

The air traffic control staff is divided into 9 crews, each having about 10 controllers, with either one or two crews on duty, depending on traffic volume. Each crew has its own supervisor. When two supervisors are on duty, one handles the administrative duties, while the other is classed as the operational supervisor. The assistants have a separate, but similar, arrangement regarding work crews and manpower utilization. They are, at all times, under the supervision of a "shift or" who is in turn responsible to the air traffic controller supervisor.

Present staffing includes about 100 operational air traffic controllers and 50 assistants.

The following table illustrates the staffing requirements for Gander ACC for a typical 24-hour summer period:

Local Time	0400-1000	1000-1800	1800-2000	2000-0400
Supervisors	1	2	1	2
Planners	1	2	1	4
Oceanic Controllers	3	7	3	5
Domestic Controllers	4	8	4	7
Clearance Delivery	-	-	-	1
Shift Senior	1	1	1	1
Assistants	4	8	4	8

During periods of lower traffic volume, generally between October and April, staffing at most positions is considerably reduced. This facilitates refresher training, staff development projects, development and implementation of new operational procedures, etc.

Shifts worked by the controller staff:

1600-0000 Local Time
2000-0400
0000-0800
0800-1600
1000-1800

The assistants work generally the same shifts, with some slight variations.

A.7.2 Administrative Staff

The air traffic control centre is managed by the Unit Chief. Under his direction are the Centre Operations Supervisor, the Data Systems Supervisor, the Performance Development Officers, the Unit Training Officer, the Unit Procedures Officer, and the Administrative Support personnel.

A.7.2 Oceanic Staffing Requirements

It is difficult to determine the precise proportion of the total Gander staff actually engaged in the oceanic operation. Clearly, the planning and ocean sectors provide service only to oceanic traffic all of the time, but the same cannot be said for the domestic sectors. The services provided in domestic airspace to both oceanic and purely domestic flights are so similar in some respects and so closely interwoven that no clear division or distinction is ever made in practice. A fairly good estimate is that 75% of the total manpower resources in Gander Centre is used to handle the oceanic traffic. (Note: A preliminary draft version of ref. 10 reported that the Gander ACC staff includes 171 ATS personnel.)

A.8 Improvement Plans

Technological advances in the aviation field in both airborne and ground-based equipment are gradually enhancing the capacity and efficiency of the oceanic control operation.

The present computer systems at Gander and Prestwick are in the process of being replaced. The new systems, which will have a greatly expanded capability, are scheduled to come on line in 1981. Initially, the new Gander system will perform

only the functions handled by the present one. However, the strip printers will be quieter and faster, and several electronic data displays will be introduced to replace certain flight progress strips (flight plan input and estimate copying), and there will be improved means of recording and conveying information. Once the Gander and Shanwick systems are in place, a number of planned enhancements will be phased in over the next several years. These include conflict prediction on westbound traffic, conflict alerting, automatic input and processing of position reports, and replacement of flight progress strips at control sectors with electronic data displays.

In addition to the new GAATS system, three other computerized systems are now being developed for the Gander Area Control Centre. One of these is a digitized radar system called JETS (Joint En route Terminal System), which will display information from a radar site on the west coast and one on the south-east coast of Newfoundland as well as from the radar situated at Gander. Another is the ICCS (Integrated Communications Control System), which will enhance the capability, and particularly the flexibility, of air/ground, inter-centre, and inter-sector communications. The third is the OIDS (Operational Information Display System), which, at the push of a button, will present to the controller an electronic display of pertinent information such as the NAT tracks and weather reports. All these systems are scheduled to be in operation when the new center opens in 1981.

APPENDIX B

SHANWICK OACC--SUPPLEMENTAL DESCRIPTIVE DATA (Excerpts from a Draft by the CAA, UK)

B.1 Information Source

This appendix consists of selected excerpts quoted directly from the draft "Description of Shanwick OACC Operation," December 1978 (ref. 14) and a questionnaire response document, April 1979, prepared by the National Air Traffic Services (NATS) of the UK Civil Aviation Authority. The quoted material is indicated by indented text in the remainder of this appendix.

B.2 Airspace Structure

B.2.1 Airspace Boundaries

Figure 2 (of the main text) illustrates the Shanwick CTA/FIR as well as the adjacent oceanic control areas which have a contiguous boundary with Shanwick. The adjacent FIR's include the Reykjavik Oceanic CTA/FIR, Scottish FIR, Shannon FIR, London FIR, France FIR, Madrid FIR and the Santa Maria and Gander CTA/FIRs.

B.2.2 Oceanic Sectorization

Sectorization is effected by flight level. For example:

Sector ER1: FL350 and above
Sector ER2: FL360, FL330
Sector ER3: FL320, FL340, FL360
Sector ER4: FL290 and below

B.3 Facilities

B.3.1 General Accommodations

The Oceanic Center at Prestwick (operated by the UK CAA) located at Atlantic House, Sherwood Road, Prestwick, Scotland, is supported by the communications station at Ballygreen, near Shannon Ireland. Certain USAF aircraft communicate with their own communications station at Croughton. The Shanwick OACC is collocated with the Scottish ATCC at Prestwick, Scotland. Figure B-1 presents a floor plan of the Shanwick OACC control room.

SUP
SUP/A

OA 4
Signal
Distn

FLIGHT PROGRESS STRIP TELEPRINTERS

REST
ROOM

SPARE	CDO 1	CDO 2	OA1	OA2	OA3	FLIGHT PLAN RECEPTION
PA1	P1	P2	P3	ER1	ER2	ER3
						ER4
						SPARE

PLANNING
SECTION

- Legends:
- P - Planning Controller
 - ER - En route controller
 - PA - Planning assistant
 - OA - Oceanic assistant
 - :CDO - Clearance delivery officer
 - SUP - Supervisor
 - SUP/A - Supervisors assistant

Source: Ref. 12

FIGURE B-1 SHANNICK OACC OPERATIONS ROOM LAYOUT

B.3.2 Data Processing

As an interim step towards automation a computer has been introduced into operational service to print Flight Progress Strips and exchange a limited amount of flight data with the Oceanic Centre at Gander.

B.4 Westbound Operations

B.4.1 Planning Sectors and Clearance Delivery

The Oceanic Center maintains planning sectors which have the responsibility of performing the strategic planning and coordinating functions which are essential to the achievement of an organized flow of traffic. Normally two sectors are established with the provision for a third controller to act primarily as a coordinator. They are responsible for ensuring that all westbound jet flights are provided with an Air Traffic Control clearance prior to entering oceanic airspace. In respect of flights operating below FL280 this service is provided by a low level en route controller. Oceanic clearances are required to provide separation for the entire NAT crossing, i.e., from oceanic airspace entry point to 'landfall' for westbound flights.

Clearance delivery officers (CDO) man the frequencies which provide a VHF/RT (radiotelephony) service for the relay of oceanic clearance to provide a VHF/RT service to flights approximately 30 to 40 minutes prior to their entering the OCA. This service covers the whole of the UK upper airspace and areas of French airspace southwards to about 48 N west of the Greenwich Meridian. South of 48 N service is provided by HF/RT or the domestic ATC authority. Flights unable to communicate on a VHF clearance frequency request clearance on HF/RT via Ballygirreen or Croughton; these requests and the clearances issued are relayed by discrete teleprinter circuits.

Clearances for aircraft departing from certain airfields adjacent to the Shanwick oceanic boundary (Proximate Airfields) are obtained from the oceanic planning sectors through the ATC telephone system.

As soon as a clearance has been accepted by an aircraft, it is passed by an air traffic control assistant to the adjacent UK or European ATCC responsible for implementing it, prior to the aircraft entering the oceanic airspace. It is the responsibility of these ATCCs to advise the OACC immediately if they are unable to implement clearances issued by the oceanic planning sector. Details of the clearance issued and other data are passed to the next OACC on the aircraft's route at an agreed time; in the case of Gander OACC data is passed on a computer to computer data link.

B.4.2 En Route Control Sectors

Once a flight enters the oceanic control area it becomes the responsibility of an en route control sector, the number in operation depending on the traffic load. There are normally four sectors established at peak flow periods to handle the varied traffic operating.

The division of the total traffic between the number of sectors established is currently effected on a flight level basis, each sector being allocated responsibility for certain flight levels. In the future this may be done on a track basis. In order to make the most efficient use of staff, sectors are combined when the workload falls.

The Air Traffic Control Service responsibility is transferred to the adjacent centre as soon as the flight crosses the boundary between the two areas concerned.

B.5 Eastbound Operations

B.5.1 The eastbound peak traffic flow, which occurs between approximately 0200 and 0800 GMT through the Shanwick OACC, is handled in a similar manner but in this case Gander ACC implements planning procedures similar to those outlined earlier at times that are appropriate to the flow of eastbound traffic.

B.5.2 Clearance data relating to flights entering or routing adjacent to the Shanwick CTA/FIR is passed by Gander to Shanwick OACC prior to the aircraft passing 40 W. Once the flight is transferred to the jurisdiction of Shanwick at 30 W, the separation already planned and implemented by Gander is monitored and adjusted, if necessary, as the flight traverses the Shanwick CTA/FIR. The flight estimate for the Shanwick eastern boundary and other details are passed to the next ATCC on the aircraft's route at an agreed time before the boundary. Transfer of control occurs automatically at the exit boundary. The details are also passed to other ATCCs when the aircraft routes close to their airspace.

B.5.3 Traffic entering the Shanwick CTA/FIR direct from Santa Maria OACC or Reykjavik ACC is handled in a similar manner, except that these ATC units have to coordinate the aircraft's route with Shanwick OACC prior to the aircraft entering Shanwick OCA.

B.6 Lateral Separation Special Procedures

For subsonic aircraft to be laterally separated a minimum of 120 nautical miles is required between the tracks, except that the following are deemed to be laterally separated:

- (a) Westbound aircraft on diverging tracks which are separated by one degree of latitude when crossing the Shanwick eastern oceanic boundary, provided that their tracks diverge to provide standard separation (i.e., 120 n.m.) by 20 W.
- (b) As (a) except that the entry points are Eagle Island VOR 5416N, 1003W and 55N, 10W, respectively, and either:
 - (i) Eagle Island and Belfast VORs are serviceable or,
 - (ii) Eagle Island VOR is serviceable and radar surveillance is provided to 55 N 10W.
- (c) Tracks spaced by 2 degrees of latitude provided that 3 degrees of latitude is the maximum change of latitude between successive points spaced at intervals of 10 degrees latitude or between a 10 degree meridian and an associated landfall. The foregoing also applies to the appropriate segments of tracks which converge to not less than 2 degrees of latitude at the standard reporting point meridians.
- (d) Traffic routing 56M, 15W to 56N, 10W and traffic routing 54N 15W to Eagle Island VOR.
- (e) Traffic routing 57N, 15W to 56N, 10W and traffic routing 55N 15W to Eagle Island VOR.
- (f) Composite tracks 60 n.m. apart.

B.7 Longitudinal Separation Special Procedures

B.7.1 Turbojet Aircraft--Same Track and Same Level

The 15 minute longitudinal separation (with Mach number technique) will apply in the following special circumstances.

- (i) Between aircraft operating on a track commencing at 55N, 10W and aircraft routing overhead Eagle Island VOR, to join the same track at or before 20W, provided either both Eagle and Belfast VORs are serviceable or Eagle Island VOR is serviceable and radar surveillance is provided to 55N.
- (ii) Westbound aircraft on the same track to 40W then diverge to 1 lateral separation at 50W subject to approval by OACC Gander on an individual basis.

- (iii) Eastbound flights (entering the Scottish UIR) on the same track to 20W, then diverging to 1 degree lateral separation at 10W, provided that separation is maintained after 10W.
- (iv) Eastbound flights (entering the Shannon UIR) on the same track to 20W, then diverging, subject to approval by Shannon on an individual basis.
- (v) In the case of turbojet aircraft operating between Iceland and the UK, the 15 minutes longitudinal separation may be further reduced to 5 minutes at Point LIMA provided that the preceding aircraft is maintaining a speed at least Mach 0.06 greater than the following aircraft, or 10 minutes if Mach 0.03 greater, and,
 - (1) both aircraft are cleared via 60N 10W and Stornoway,
or
 - (2) both aircraft are cleared via 59N 10W and Benbecula,
or
 - (3) one aircraft is cleared via 60N, 10W and Stornoway and the other aircraft via 59N 10W and Benbecula.

When passing estimates to Scottish ATCC, Shanwick will indicate in these cases that reduced longitudinal separation has been applied.

B.7.2 Turbojet Aircraft--Climbing and Descending

Aircraft operating South of 70N which are climbing or descending through the levels of other aircraft on the same track require at least:

15 minutes at the time levels are crossed provided that the concerned aircraft...do not enter the New York CTA/FIR immediately after flight in the Santa Maria CTA/FIR or will not penetrate south of 37 N...However, 15 minutes may be used between aircraft the tracks of which lie in the Santa Maria OCA prior to entry into the New York CTA/FIR provided that the level change is completed within the Shanwick CTA/FIR. The reduced entry separations of 10 and 5 minutes associated with speed differentials shall not be used in climbs or descends pending ICAO agreement.

B.7.3 Turbojet Aircraft--Reciprocal Tracks

Aircraft operating South of 70N climbing or descending through opposite direction traffic: vertical separation shall be provided for at least 20 minutes before aircraft are estimated to pass until 20 minutes after they are estimated to have passed.

B.7.4 Non-turbojet Aircraft

A minimum of 30 minutes is required between aircraft:

- (a) flying on the same track at the same flight level,
- (b) which are climbing or descending through the level of other aircraft on the same track,
- (c) which are on crossing tracks at the same flight level,
- (d) which are climbing or descending through opposite direction traffic. Vertical separation shall be provided from at least 30 minutes before the aircraft are estimated to pass until 30 minutes after they are estimated to have passed.

B.8 Organized Track Structure Lateral Separation

The organized track structure is established so that each track is laterally separated from all other organized tracks in the same structure and from airspace reservation areas (unless vertical separation exists). Exceptions are when one track is a tributary track from the Iberian Peninsula joining the most southern track in the Shanwick/Gander area, or when infrequently some night tracks are active concurrently with some day tracks or when necessary due to weather, etc. In these situations the flight levels available on one track will not be available on the other track(s).

The following rules are applied to effect lateral or deemed lateral separation:

- (a) On tracks spaced 2 degrees of latitude apart, 3 degrees of latitude is the maximum change permitted between any 10 degrees of longitude or between a 10 degree meridian and an associated landfall.
- (b) On composite tracks spaced 1 degree of latitude apart, 3 degrees of latitude is the maximum change permitted between any 10 degrees of longitude or between any 10 degree meridian and an associated landfall, subject to the proviso that if either coordinate of any 10 degree segment

(or any segment between a 10 degree meridian and an associated landfall) penetrate north of 56 N, then the maximum latitude change in that segment must be less than 3 degrees.

Under exceptional circumstances, e.g., limited warning or Rocket firing by Soviet ship(s) it may be necessary to use more than 3 degrees in (a) or (b) but any increase must be agreed with adjacent centres involved.

- (c) Composite tracks via 55N, 15 W (or 20 W) - 55 N, 10 W and 54 N 15W - EAGLE may be established simultaneously and used for eastbound or mixed traffic flows subject to establishing certain procedures with Shannon ATCC.
- (d) An outer track of the composite system may commence at an OCA entry point which is laterally 120 n.m. or more from the entry point of the adjacent composite track and converge to a lateral separation of 60 n.m. at an en route reporting point provided that at a point ten degrees of longitude before this reporting point the two tracks are separated by not less than 120 n.m. or more than 180 n.m. In the particular case of composite tracks being specified as 52 N, 15 W - 52 N 20 W and 50 N, 08 W - 51 N, 20 W the angle of convergence of these two composite tracks is acceptable.
- (e) An outer track of the composite system may diverge from the adjacent composite track at an en route reporting point provided that the two tracks continue to diverge until standard lateral separation is established.

Aircraft may be cleared to join the outer track of a composite track system at points other than the normal entry points into oceanic control areas provided that:

The specified longitudinal, i.e., at least 20 minutes or vertical separation will exist between such aircraft and others operating along the track.

The clearance provides for the joining to be effected via a track extending from the point of joining and a point which at 10 degrees of longitude from the joining point is laterally not less than 60 miles and not more than 120 miles distant from the track in question.

B.9 Emergency Procedures

Although all possible contingencies cannot be covered, the following procedures provide for such cases as inability to maintain assigned level due to weather, aircraft performance, pressurization failure and problems associated with high level

AD-A123 974

OCEANIC AREA SYSTEM IMPROVEMENT STUDY (OASIS) VOLUME II 20
NORTH ATLANTIC RE. (U) SRI INTERNATIONAL MENLO PARK CA
G J COULURIS SEP 81 OASIS-NAT-ATS FAA-EM-81-17-2

UNCLASSIFIED

DOT-FA79WA-4265

F/G 17/7

NL

END

DATE

FORMED

83

DTIC

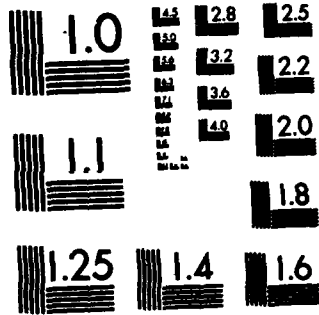

MICROCOPY RESOLUTION TEST CHART
 NATIONAL BUREAU OF STANDARDS-1963-A

supersonic flight. They are intended for guidance only and are applicable primarily when rapid descent, turn back, or both, are required. The pilot is required to use his judgement to determine the sequence of actions taken, having regard to the specific circumstances.

B.9.1 General Procedures

If either a subsonic or supersonic aircraft is unable to continue flight in accordance with its ATC clearance, a revised clearance shall, whenever possible, be obtained prior to initiating any action, using the radiotelephony distress or urgency signal as appropriate. If prior clearance cannot be obtained, an ATC clearance shall be obtained at the earliest possible time and in the meantime the aircraft shall broadcast its position (including the Track Code, if appropriate) and intentions, on frequency 121.5 MHz at suitable intervals until ATC clearance is received.

B.9.2 Special Procedures for Subsonic Aircraft

If unable to comply with the provisions of the general procedures, the aircraft should leave its assigned track by turning 90 degrees to the right or left whenever this is possible. The direction of the turn should be determined by the position of the aircraft relative to any organized track system, e.g., whether the aircraft is outside, at the edge of, or within the system, whether composite separation is used, the levels allocated to adjacent tracks and, if appropriate, terrain clearance. An aircraft able to maintain its assigned level should, nevertheless, climb or descend 150 meters (500 ft) while acquiring and maintaining in either direction a track laterally separated by 30 n.m. from its assigned track. An aircraft not able to maintain its assigned level should start its descent while turning to acquire and maintain in either direction a track laterally separated by 30 n.m. from its assigned track. For subsequent level flight, a level should be selected which differs by 150 m (500 ft) from those normally used.

B.9.3 Special Procedure for Supersonic Aircraft

If a supersonic aircraft is unable to continue flight to its destination and a reversal of track is necessary, it should:

- (1) When operating on an outer track of a multi-track system, turn away from the adjacent track;

- (2) When operating on a random track or on an inner track of a multi-track system, turn either left or right as follows:
 - (a) if the turn is to be made to the right, the aircraft should attain a position 30 n.m. to the left of the assigned track and then turn to the right onto its reciprocal heading, at the greatest practical rate of turn;
 - (b) if the turn is to be made to the left, the aircraft should attain a position 30 n.m. to the right of the assigned track and then turn to the left onto its reciprocal heading, at the greatest practical rate of turn;
- (3) While executing the turn-back, the aircraft should lose height so that it will be at least 6,000 ft below the level at which turn-back was started, by the time the turn-back is completed;
- (4) When turn-back is completed, heading should be adjusted to maintain a lateral displacement of 30 n.m. from the original track in the reverse direction, if possible maintaining the flight level attained on completion of the turn.

A supersonic aircraft compelled to make a rapid descent whether continuing to destination or turning back, should, if its descent will conflict with an organized track system for subsonic air traffic:

- (1) Proceed to a point mid-way between a convenient pair of subsonic tracks, prior to entering that track system;
- (2) While descending between FL450 and FL280, maintain a track which is mid-way between and parallel with the subsonic tracks;
- (3) After passing through FL280, proceed in accordance with the relevant provisions for subsonic aircraft.

The pilot of a supersonic aircraft which, during any period of its flight, is likely to operate in the vicinity of an organized track system for subsonic air traffic, shall be in possession of detailed information regarding that system as it is in operation during the period of his flight.

B.9.4 Adherence to ATC Approved Route

If an aircraft has inadvertently deviated from the route specified in the ATC clearance it shall forthwith take action to regain such route within 100 nautical miles from the position at which the deviation was observed.

B.10 Personnel

Manning during peak periods is as follows:

- (a) one (1) watch supervisor
- (b) three (3) planning controllers
- (c) four (4) en route sector controllers
- (d) seven (7) oceanic assistants
- (e) two (2) clearance delivery officers

B.11 Improvement Plans

The new flight data processing system (FDPS) which is due to become operational in the early 1980's, will provide more facilities and have greater development potential than the existing system. In particular controllers will operate from positions which are equipped with electronic flight data displays (EDDs), interactive update devices and receive-only printers. Flight progress strips will also be printed and updated to form a fall-back display during the early life of the system. In addition other major features include the exchange of flight data with other ATC units as well as Gander, assisting the composition of locally originated input messages, monitoring the progress of flights (based on on-line position reports from Ballygireen and Croughton), detecting conflicts and overdue position reports, resolving conflicts and recording data. (Note: U.S. Air Force aircraft communicate with Shanwick OACC via their A/G station at Croughton, UK).

APPENDIX C

NEW YORK ACC--SUPPLEMENTAL DESCRIPTIVE DATA

C.1 Information Source

This appendix is based on observational visits to the New York ACC in December 1978 and in 1979.

C.2 Airspace Structure

C.2.1 Airspace Boundaries

The oceanic and adjacent domestic airspace responsibilities assigned to Area F of the New York ACC are shown in Figure C-1. Adjacent oceanic ATS units include the Gander, Santa Maria, San Juan and Miami ACCs and adjacent domestic en route units include Moncton, Boston, Washington, Jacksonville and Miami Centers.

C.2.2 Oceanic Sectorization

Five manual (i.e., non-radar) geographically segregated control sectors provide air traffic services for the Oceanic Area under the jurisdiction of the New York ACC. These sectors are in Area F which also includes four radar sectors and one manual non-control sector used for military coordination. The following Area F sectors corresponding to the geographic areas of responsibilities presented in Figure C-1:

Sector ID Number	Sector Name	Type	Airspace
65	Atlantic	Domestic/Radar	Low & High
66	Hampton	Domestic/Radar	High
67	Sardine	Domestic/Radar	Low
68	Micke	Domestic/Radar	Low
81	Amis	Coordination/Manual	-
82	Champ	Oceanic/Manual	Low & High
83	Smelt	Oceanic/Manual	Low & High
84	Mercury	Oceanic/Manual	High
85	Gemini	Oceanic/Manual	High
86	Apollo	Oceanic/Manual	Low

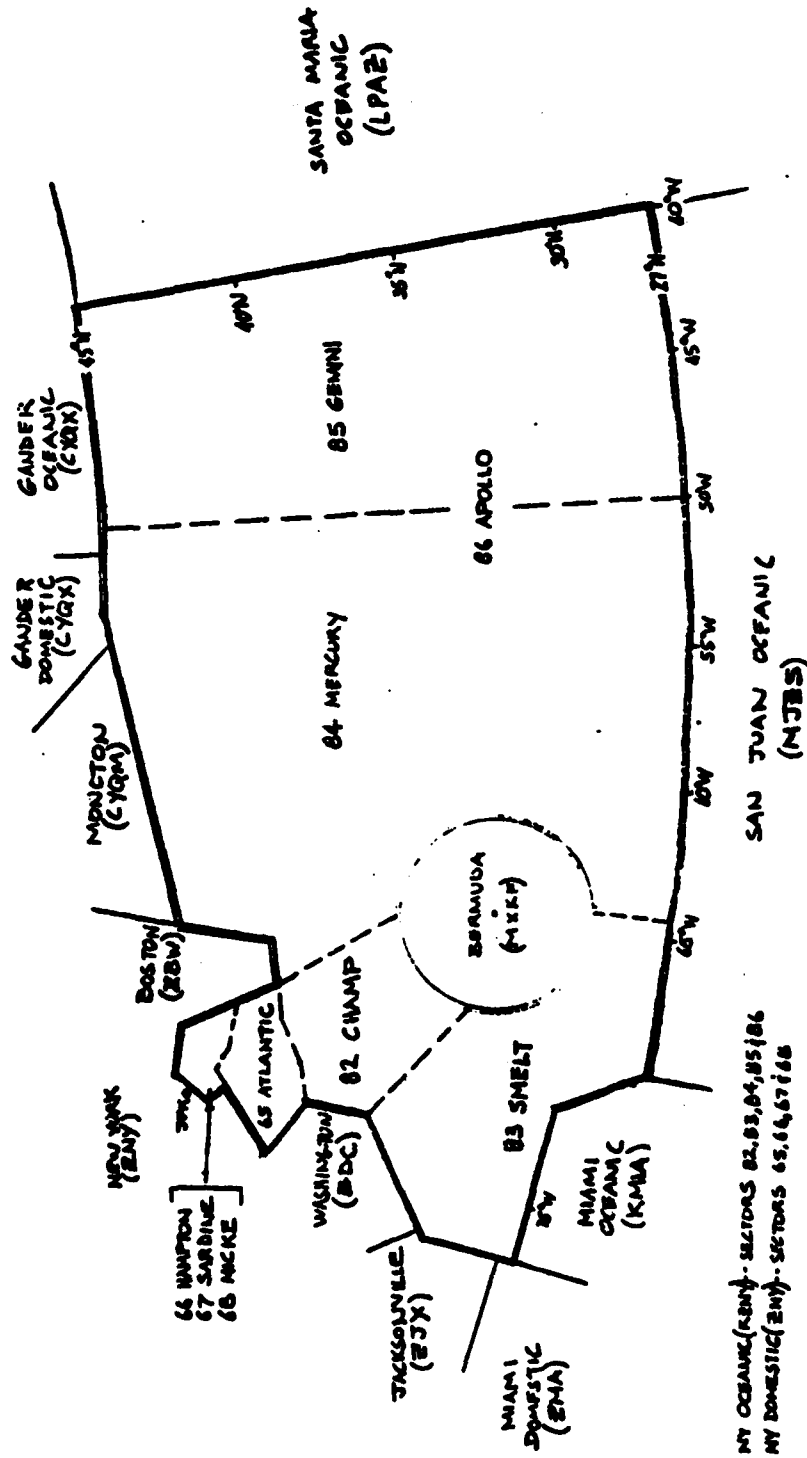

NY OCEANIC (KMY) - 82, 83, 84, 85, 86
 NY DOMESTIC (JNY) - 87, 88, 89, 90, 91, 92, 93, 94, 95, 96, 97, 98, 99, 100

FIGURE C-1 NEW YORK ACC AREA F AIRSPACE SCHEMATIC

C.3 Facilities

C.3.1 General Accommodations

The New York Area Control Center is located at Ronkonkoma, New York, and is designated as an air route traffic control center (ARTCC) by the FAA, the ATS provider authority. Figure C-2 shows the control room layout.

C.3.2 Data Processing

Domestic flight plan filings received by teletype are automatically processed into the computerized flight data processing (FDP) system, while flight plans routinely stored in the computer files are amended and activated based on phone call data. However, international flight plans filed using the ICAO format are not directly compatible with the FDP processing format and must be manually entered rather than automatically processed from teletype data.

The FDP system forwards flight data between mainland FAA facilities and supports flight strip printing at individual sector positions. The flight strips include computer estimated time of position crossings which are based in part on forecast wind conditions. The oceanic meteorological forecasts developed by the U.S. National Weather Service (NWS) for approximately nine flight levels at 24 grid points are manually entered twice a day into New York ACC's computer system. Actual weather data received from pilots also are manually entered.

C.3.5 Operating Positions

Controller positions used at each sector are shown in Figure C-2. Each of the domestic radar sectors includes a radio (R) controller, a handoff or data (D) controller, and share an assistant (A) controller position; the R controller is responsible for sector operations. The oceanic sectors include D and A positions with the D controller responsible for sector operations under the manual control mode. The sector team is variable, and the number of positions actively manned at any time depends on the traffic loading and workload conditions. At minimum, one R controller would operate an active radar sector and one D controller would man an active manual oceanic sector; additional positions would be manned to alleviate the lead position workload during heavier traffic loadings.

Controllers rotate their duty assignments through the radar and manual sector positions and thereby maintain proficiency in domestic and oceanic control operations.

C.4 Operational Procedures

To develop an understanding of the operational procedures used in the domestic radar and oceanic manual environments as well as in the transition between the two environments, consider the control procedures required to handle a single hypothetical airline IFR flight from John F. Kennedy International Airport to San Juan in the Caribbean. The aircraft will fly through airspace under the control of selected terminal control sectors and New York Center's Sector 39 Manta in Area C, and Sector 65 Atlantic, Sector 82 Champ, and Sector 83 Smelt in Area F; a non-control position in the New York ACC, Sector 59 JFK, will provide departure clearance delivery check service. The oceanic portion of the flight will be on a designated preferential ATS route. Generally A20 is the preferential route to San Juan from New York; A23 is an alternative preferential route. Other frequently used routes in the area include preferential routes to Bermuda such as: B23 and A21 from New York; A21 from Boston; and Red R12 from Washington, DC.

Prior to the airliner's departure from the airport, a flight plan is filed by the company dispatch office and entered into the ATC computerized flight data processing (FDP) system. Paper flight strips describing the flight plan are automatically printed and delivered to selected sectors in the New York Center and local terminal control facilities; the latter include the Kennedy Airport Traffic Control Tower (ATCT) and the New York Common IFR Room (CIFRR) which provides terminal radar approach and departure control service. The Center sectors receiving the initial flight strips are Sector 59 JFK and Sector 39 Manta. Sector 59 JFK is specially designated to check departure clearances for flights from Kennedy Airport and Sector 39 Manta will be the first sector in the Center to actually control the aircraft.

The Sector 59 JFK D-controller (see Figure C-2) reviews the flight plan shown on the flight strip and amends the flight plan as necessary to correct errors or to incorporate recent ATC required routing restrictions. Amendments are manually entered by keyboard into the computerized FDP system, and printed flight strips with the revisions are automatically distributed to the relevant sectors. If no amendments are required, the initial flight strips are used to clear the flight. Receipt by the tower of a departure strip constitutes center issuance of an IFR clearance and further coordination is not necessary. Using tower to pilot radio voice communications, a tower controller delivers the departure clearance by reading the route of flight as filed or as amended. A tower controller also issues the aircraft's takeoff release instructions when the aircraft is in position to depart.

Immediately after takeoff, the aircraft is tracked on radar through terminal area departure airspace under the jurisdiction of CIFRR radar controllers who maintain air/ground (A/G) VHF communications contact. The CIFRR controllers then hand off control jurisdiction for the aircraft to center radar controllers. New York Center's Sector 39 Manta

would receive the aircraft from the CIFRR and then hand it off to Sector 65 Atlantic of Area F. Updated flight strips would have been automatically printed and delivered to Sector 65 Atlantic in anticipation of the flight's arrival. Similar flight strip deliveries precede the flight's expected time of arrival in downstream sectors. The portion of the flight from departure through Sector 65 Atlantic is under radar control and VHF A/G communications. However, the next sector to receive the aircraft will be the oceanic manual Sector 82 Champ which does not have radar and VHF A/G communication capabilities.

When the aircraft is in Sector 65 Atlantic's jurisdiction, the Sector 82 Champ oceanic controller (who is operating the D-controller in latter sector) coordinates by interphone with the Sector 65 Atlantic D-controller to establish the oceanic clearance for the aircraft. During lighter traffic periods, the coordination may be with the Sector 65 Atlantic R-controller. The coordination specifically involves confirmation of the altitude clearance and requires the oceanic controller to use the flight strip data presentation to check separation requirements against the current traffic situation and determine whether the route of flight at the requested or filed altitude is available. If the altitude is not available, the oceanic controller identifies available alternative altitudes or alternative routings which the Sector 65 Atlantic D-controller relays (by face-to-face speech) to Sector R-controller. The latter in turn advises the pilot using VHF A/G communications. The pilot selects an option or negotiates an alternative, and the results are relayed from the Sector 65 Atlantic R-controller to the D-controller to the Sector 82 Champ oceanic controller. The entire oceanic portion of the route of flight is read verbatim by the Sector 65 Atlantic R-controller to the pilot as part of the full oceanic clearance delivery process. Controllers of both sectors manually update their flight strip data and the Sector 65 (Atlantic) controllers use manual keyboard entries to update the computerized flight data.

The Sector 65 Atlantic R-controller clears the aircraft through this Sector's airspace to assure conformance with the clearance restrictions defined by the oceanic controller. Such restrictions may include position, heading, altitude, speed or time of fix crossing requirements which must be satisfied when the aircraft is handed off to Sector 82 Champ. The aircraft is maneuvered into conformance with the oceanic separation requirements while it is still under radar coverage in Sector 65 Atlantic, and the transition from radar to non-radar control environments thereby is accomplished when the R-controller instructs the pilot to change A/G radio frequency and contact the New York ARINC Communications Center.

The aircraft proceeds into Sector 82 Champ where procedural control techniques are applied by the oceanic controller. Flight strip data presented on a flight progress board are used for flight following and manual updates based on pilot position reports are used to monitor flight movement. Communications between the controller and pilot are

carried out indirectly using the ARINC HF or VHF communications system. The ARINC system services civil aircraft while alternative communication systems such as McDill Airways, Florida, service military aircraft.

In the case of the example flight, A/G voice communications are performed by an HF radio operator in ARINC's New York Communications Center. Using a keyboard entry device, the operator encodes the pilot voice message, such as a routine position report or an altitude change request, into a machine-readable format and a printed message is forwarded by teletype to the Sector 82 Champ oceanic controller. Pilot position reports and estimates relayed in this manner are hand copied onto a flight strip by the oceanic controller. In the case of a priority situation (e.g., emergency or clearance request to avoid severe air turbulence), the ARINC operator would directly advise the oceanic controller by means of a voice interphone landline connection. All messages from the controller to the pilot are initiated by an interphone voice message to the ARINC operator who relays the message to the pilot using the HF voice communications system. Direct voice patches between controllers and pilots are possible for special circumstances but are used infrequently.

The oceanic controller reviews the pilot reports and estimates of time over fix and next fix, and searches for potential conflict situations--violations of minimum separation requirements between aircraft. Controllers report that the preferred method for resolving conflicts is to revise the altitude clearance of aircraft and that successively less preferred techniques are to apply time over fix crossing restrictions (with at most 2-3 minutes delay to an aircraft) and route revisions.

Conflict resolution instructions are relayed to a pilot by the ARINC operator who in turn must relay the pilot's response or confirmation back to the controller. New York ACC control personnel have indicated a general dissatisfaction with these communication procedures, stating that the response time between instruction issuance and pilot response is of excessive duration, sometimes more than 10 minutes. Note: an ARINC New York Communication Center staff member reported that response time by a pilot to a radio operator's message is usually of the order of 1 minute. This response time does not necessarily include the teletype network processing time to relay the message to the oceanic ATC sector. The controllers stated a preference for direct A/G voice communications for the purpose of expediting control operations. Such direct A/G voice capabilities would be helpful in maintaining timely cognizance of not only conflict resolution actions but also other maneuvers such as pilot "request for higher passing" (i.e., altitude change requests) at some fix where the controllers typically would like the step climb to be achieved within a 100 mile longitudinal distance. Some controllers felt that they would prefer direct A/G voice only if the service was VHF or of VHF voice quality, while others stated that HF A/G voice capabilities would be worthwhile despite possible deficiencies in transmission quality. Due to time constraints, an extensive survey was not conducted to determine whether any controllers objected to direct A/G voice capabilities.

The aircraft would proceed through Sector 82 Champ, be handed off to Sector 83 Smelt, and eventually exit the New York ACC's oceanic area when it is handed off to an oceanic sector of the San Juan Center. Interphone coordination with the San Juan sector for the handoff would be initiated by the Sector 83 Smelt oceanic controller approximately 60 minutes before the aircraft is expected to cross the center's boundary. The San Juan ACC would have received a teletyped flight plan from the airline dispatch office prior to the coordination.

Aircraft eastbound on other routes through the New York oceanic area follow procedures similar to those described in the preceding paragraphs. Subsonic flights to the Iberian Peninsula and supersonic flights receive an oceanic route clearance while under radar control by Sector 66 Hampton, pass through the Boston Center's radar airspace where the oceanic entry altitude is again coordinated with an oceanic controller, and fly through the oceanic route clearance while under radar control by Sector 65 Hampton, New York Center's Sector 94 Mercury and Sector 85 Gemini. Procedural control techniques are essentially the same in the New York ACC's eastern airspace (Sectors 84, 85 and 86) as those applied in the western airspace (Sectors 82 and 83) except the lateral separation in the eastern area is 120 n.m. rather than 90 n.m.

Controllers report that eastbound aircraft handed off in mid-ocean to the Gander Center and which may cross or merge with the Organized Track System (OTS) are normally kept at their requested altitude until 1 to 1 1/2 hours before the scheduled boundary crossing. At this time, interphone coordination is initiated with Gander and the New York oceanic controller clears the aircraft to an altitude coordinated with Gander.

Eastbound aircraft from U.S. origins bound for OTS entry points generally pass through radar sectors of Boston, Moncton and Gander Centers and use one of the published North American Routes (NARs). The New York ACC's sectors would not be involved in oceanic clearance for those aircraft (other than routine departure clearance services).

Westbound and northbound aircraft flying through the New York oceanic area require control procedures analogous to those eastbound and southbound aircraft. Normally, the first New York oceanic sector to receive an inbound flight would review and verify the oceanic clearance.

C.5 Personnel

The Area F sectors are selectively activated or combined in response to traffic demand, and, therefore, all sectors are not in operation at all times. For example, during a period of light activity over the Western Atlantic, the Sector 83 Smelt controllers may handle all aircraft in the area and the Sector 82 Champ sector positions may not be manned. The latter sector would be activated when traffic loading

increases beyond the workload capabilities of the single sector team. In the oceanic sectors, controllers report that 40 aircraft represents a typical maximum instantaneous traffic loading that can be worked under usual routing conditions without saturating controller traffic handling capabilities.

Under normal manning circumstances, one data controller is assigned to each active oceanic sector and one A-controller delivers strips to Sectors 82 Champ and 83 Smelt and one A-controller supports Sectors 84 Mercury, Sector 85 Gemini and Sector 86 Apollo. New York ACC personnel reported that the low altitude Sector 86 Apollo is very rarely activated, and that Sector 85 Gemini is sometimes activated; Sector 84 Mercury often has jurisdiction over the entire easterly New York CTA/FIR.

C.6 Improvement Plans

The New York ACC operations personnel currently are experimenting with procedural and technical changes that are under consideration for future implementation but are not necessarily part of formal international agreements or plans for future establishment. The procedural changes include experimental fixed tracks, such as those illustrated in Figure C-3, that currently are temporarily in place in the New York CTA/FIR. In addition to the experimental tracks shown in Figure C-3, experimental fixed tracks are in place in the western New York CTA/FIR that cross the established ATS track network. The latter experimental tracks are used to marshal eastbound and westbound trans-Atlantic air traffic onto a few routes and thereby facilitate the easy management and resolution of conflicts between the trans-Atlantic traffic and ATS track traffic. Similarly, tracks shown in Figure C-3 simplify the management of traffic in the eastern New York oceanic airspace. However, the experimental tracks tend to transfer conflict resolution problems to adjacent facilities such as the San Juan ACC, and restrict the flexibility of flight planners in determining oceanic tracks for their aircraft.

The New York ACC is experimenting with an electronic display of simulated air traffic in the oceanic airspace. The display is not used for operational purposes and plans for its future use and application have not been determined.

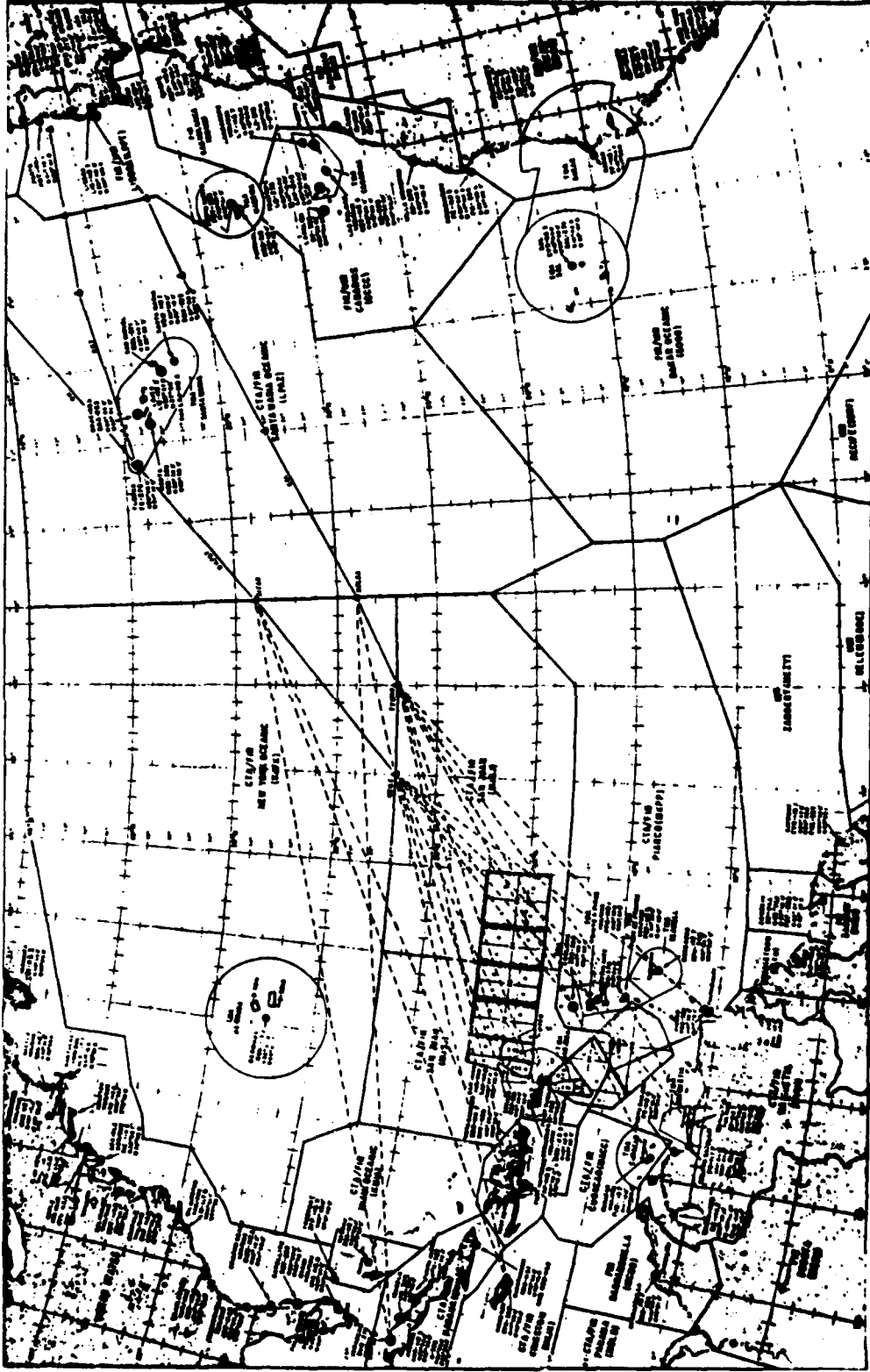

Source: New York ACC

FIGURE C-3 NEW YORK CTA/FIR EXPERIMENTAL ROUTES

APPENDIX D

SANTA MARIA ACC--SUPPLEMENTAL DESCRIPTIVE DATA (Excerpts from an ACO Letter Draft Report)

D.1 Information Source

This appendix consists largely of selected excerpts quoted directly from a letter draft report (ref. 17) prepared by the AEROSAT Coordination Office (ACO) describing information obtained during a May 1979 data gathering meeting held in Lisbon, Portugal, by an ACO staff member and representatives of the ATS Director General of Civil Aviation (DGAC) and the Airports and Air Navigation Public Enterprise (ANA/EP); the latter are the ATS provider authorities. The quoted material is indicated by indented text in the remainder of this appendix.

D.2 Airspace Structure

D.2.1 Airspace Boundaries

The Santa Maria oceanic CTA/FIR and the local domestic terminal area (TMA) airspace are shown in Figure 2 (of the main text).

D.2.2 Oceanic Sectorization

Altitude sectoring is employed. The sector boundaries and the number of sectors vary with the traffic and are independent of the sectoring in adjacent FIRs.

D.3 Facilities

D.3.1 General Accommodations

The Santa Maria Oceanic CTA and Sant Maria TMA are located in the same room and are adjacent to the teletypewriter room and the radio room (see Figure D-1).

D.3.2 Operating Positions

Two active control sectors and one standby sector are operational in the CTA. Each sector is manned by one controller and one assistant. The present control room layout is shown in Figure D-2 and includes the planned installation of a quiet teleprinter behind each controller.

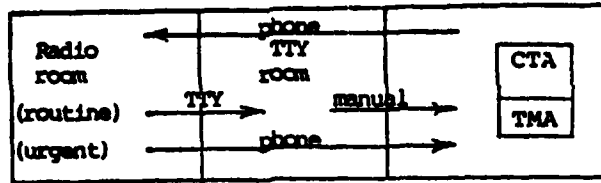

Source: Ref. 17

FIGURE D-1. SANTA MARIA ACC AND COM SUPPORT

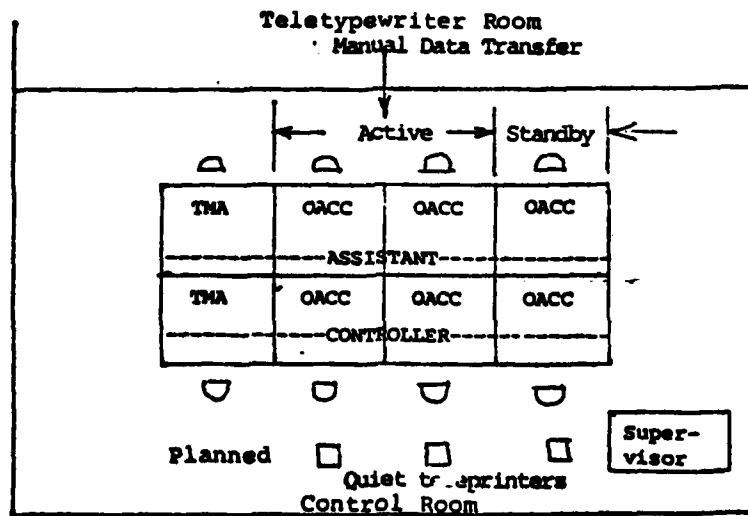

Source: Ref. 17

FIGURE D-2 SANTA MARIA ACC CONTROL ROOM LAYOUT

The standby positions are staffed during the watches in which the traffic peaks are expected. Typically, the eastbound traffic peak occurs between 0300 and 0500; the westbound traffic peak occurs between 1200 and 1400.

D.3.3 Data Processing

Because automatic processing is not available, flight plan data are processed by the staff. If a flight occupies more than one altitude sector within the OACC, the flight data is forwarded manually. Flight data forwarding between OACCs uses AFTN routinely but may use ATS direct speech circuits when urgent. Previously, each flight was represented by a flight strip per median (i.e., longitude crossed) and per altitude sector occupied. At present, the Santa Maria OACC is conducting a trial with one strip per flight in each sector occupied.

D.4 Operating Procedures

Within the FIR boundary, overflying international traffic has preference over domestic traffic arriving (descending) or departing (climbing) the Santa Maria TMA (terminal control area). Westbound traffic entering Santa Maria FIR may be subject to flow control restrictions until a new ATS system has completed its trial. Also, westbound traffic approaching Santa Maria from France may be at flight level 260 because of air traffic restrictions in France.

Coordination of oceanic traffic departing Madrid and Lisbon is initiated as soon as possible after takeoff. Traffic from New York FIR and northern Europe is coordinated 1-2 hour in advance.

Westbound random traffic generally uses "anchor points" for flight planning. Two anchor points are utilized either by the Iberian Peninsula Organized Track System or for two tracks of the NAT OTS under "south about" conditions: The Dirma anchor point is defined by VOR/DME or INS coordinates; and the Bugio anchor point is defined by a VOR intersection or INS coordinates.

Usually, no restrictions are issued to domestic controllers by oceanic controllers to set-up traffic for entry to oceanic area. When military exercises are being conducted in the Lisbon FIR/UIR, a corridor is arranged for airline departures from Lisbon and Madrid.

Domestic controllers do not apply vectoring or speed control techniques to aircraft approaching the oceanic airspace boundary. Pilots are requested to follow time-to-boundary instructions.

The differences between the time an aircraft is expected to enter the Santa Maria airspace and the time it actually arrives depends on the direction of entry. The characteristic differences are 2-3 minutes in the case of entries from Shanwick, 3-5 minutes for entries from New York and 10 minutes for entries from Africa. However, the latter figure will be reduced significantly when the SAL (Cape Verde) FIR is implemented in the near future. (The new FIR is the northern portion of the Dakar oceanic FIR/UIR and will be based on facilities located on Cape Verde Islands.)

Clearances are issued involving a pre-stated altitude change. For example, either a Caribbean-to-Europe flight or a Dakar-to-New York flight could be given a clearance to proceed on a requested flight level with a specific fix given to begin descent to a flight level on a track crossing below the organized track system (OTS).

D.5.8 Since Santa Maria OACC does not have any data processing equipment, handoffs to other oceanic centres and the coordination of flights going from oceanic to domestic airspace utilize the available voice or teletypewriter circuits.

APPENDIX E

REYKJAVIK ACC--SUPPLEMENTAL DESCRIPTIVE DATA (Excerpts from a Paper by DCA, Iceland)

E.1 Information Source

This appendix contains selected excerpts quoted directly from a working paper submitted by the Chief, Air Traffic Services, Directorate of Civil Aviation (DCA), Iceland. The paper was forwarded to the ACO in response to an April 1979 data request and originally was presented by Iceland at the first meeting of the Special North Atlantic Panel (SNAP), Montreal, March 1976; the paper is referred to as "SNAP-WP/2" (ref. 18). The quoted material is indicated by indented text in the remainder of this appendix.

E.2 Airspace Structure

E.2.1 Airspace Boundaries

The Reykjavik Oceanic CTA/FIR and the local domestic airspaces are shown in Figure 2 of the main text. ATS units having jurisdiction over adjacent airspace include the Gander ACC, Shanwick OACC, Bodo FIR Edmonton ACC and the Sondrestrom FIC. The latter unit has jurisdiction of airspace over northern Greenland under FL195 which is underneath a shelf of the Reykjavik CTA/FIR.

E.2.2 Oceanic Sectorization

Sectorization of the oceanic CTA/FIR is effected by flight level segregation which during peak periods is (ref. 18):

FL350 and above
FL330 and FL310
FL290 and FL280
FL270 and below.

E.3 Facilities

E.3.1 Background--Joint Financing (JF)

The ACC has been in continuous operation since the summer of 1946. In accordance with the "Agreement on the Joint Financing of Certain Air Navigation Services in Iceland" (ICAO Doc. 7727-JS/564) the Government of Iceland undertakes to operate:

"An area control center located at Reykjavik to be in continuous operation to safeguard the North Atlantic International operations through the Iceland control area."

E.3.2 Functions

The principal objectives and functions of the ACC have been defined as follows:

- (1) The provision of the following air traffic services:
 - a) Area control service in the Reykjavik CTA.
 - b) Approach control service for those aerodromes in the Reykjavik FIR not being served by separate approach control service units.
 - c) Flight information service and alerting service in the Reykjavik FIR except for those portions of the airspace or for that air traffic assigned to other ATS units.
- (2) The provision of the required services of a rescue coordination center for the Reykjavik FIR, unless or until such functions are transferred to a separate unit established for that purpose.

E.3.5 General Accommodations

The Reykjavik ACC is located on Reykjavik Airport. Figure E-1 shows the floor plan for the main components of the ACC.

E.3.6 Operating Positions

The sectorization indicated in the floor plan is established for peak traffic situations. During night, and other periods of lesser traffic activity, two or more sectors may be combined. All ATS staff in the room labeled "Oceanic-ACC" comes under joint financing. These controllers use the oceanic separation standards specified in ICAO Doc. 7030 (ref. 4), except in the provision of approach control service for the Faroe Isles where reduced separation is applied. Flight plans, position reports from the Gufunes communications station, and other pertinent AFTN data is processed in the adjacent telecommunications room.

E.4 International Air Traffic Operations

E.4.1 International Air Traffic

The decrease in the number of flights in 1964 was due to a realignment of FIR boundaries off the southern tip of Greenland which resulted in most of the "main flow" traffic traversing the North Atlantic without penetrating the Reykjavik FIR. The decline in the number of propeller aircraft has been slower in the Reykjavik FIR than in the other NAT oceanic areas. This is due to two reasons. Firstly, most general aviation flights fly the northern route across the North Atlantic with an intermediate stop in Iceland, and secondly, a considerable number of military propeller aircraft are based in Iceland.

E.4.2 Operating Procedures

If an international flight can be provided with acceptable flight levels and/or routings by the application of oceanic separation standards, that flight will normally be handled only by the "Oceanic-ACC." However, if, and this is a much more frequent case, an ATC problem evolves which could only be solved by the application of reduced separation offered by the SSR and/or the short-range navigation aids located in Iceland (VORs, DMEs, NDBs), and within the reliable range of these facilities, then this problem is referred for "tactical resolution" to the high level sector of the "Domestic-ACC." These air traffic controllers have access to the SSR displays and the pilot-to-controller VHF network. One 24-hour controller position is charged to joint financing.

It should be emphasized that the flow of international traffic through the Reykjavik FIR is primarily of a random nature, and as such presents a relatively greater ATC workload than flights on an organized track system. This applies both to the planning and en route control of flights. Furthermore, the flow of international air traffic through the Reykjavik FIR is subject to considerable day-to-day variations, primarily dependent upon the prevailing weather situation in the North Atlantic area, and the consequential location of the NAT Organized Track System.

E.5 Personnel

E.5.1 Staffing Level

The allocation of the ATS staff at Reykjavik and Keflavik ATS units, according to traffic category (international/domestic and civil/military), is shown in Table E-1.

TABLE E-1

Allocation of ATS Staff at Reykjavik and Keflavik ATS Units According to Traffic Category (International/Domestic - Civil/Military):

ATS Unit Traffic Category	Day- shift	Night shift	Average shift	Total for 4 teams	"Allocation"	
					%	%
<u>REYKJAVIK/KEFLAVIK, TOTAL</u>	<u>17.0</u>	<u>11.0</u>	<u>14.0</u>	<u>56</u>	-	100.0
<u>REYKJAVIK-ACC, Total</u>	<u>10.0</u>	<u>7.0</u>	8.5	34	100.0	60.7
" International, total	7.5	5.5	6.5	26 JF	76.5	46.4
" " civil	6.0	4.0	5.0	20	98.8	39.7
" " milit.	1.5	1.5	1.5	6	17.7	10.7
" Domestic, total	2.5	1.5	2.0	8	23.5	14.3
" " civil	1.5	1.5	1.5	6	17.6	10.7
" " military	1.0	-	0.5	2	5.9	3.6
<u>REYKJAVIK-APP/TWR, Total</u>	<u>3.0</u>	<u>1.0</u>	2.0	<u>8</u>	100.0	14.3
" International, total	-	-	-	-	-	-
" " civil	-	-	-	-	-	-
" " milit.	-	-	-	-	-	-
" Domestic, total	3.0	1.0	2.0	8	100.0	14.3
" " civil	3.0	1.0	2.0	8	100.0	14.3
" " military	-	-	-	-	-	-
<u>KEFLAVIK-APP/TWR, Total</u>	<u>4.0</u>	<u>3.0</u>	3.5	<u>14</u>	100.0	25.0
" International, total	1.0	1.0	1.0	4	28.6	7.1
" " civil	1.0	1.0	1.0	4	28.6	7.1
" " milit.	-	-	-	-	-	-
" Domestic, total	3.0	2.0	2.5	10	71.4	17.9
" " civil	1.0	-	0.5	2	14.3	3.6
" " military	2.0	2.0	2.0	8	57.1	14.3
<u>ALL ABOVE ATS UNITS</u>						
International, total	8.5	6.5	7.5	30	-	53.6
Domestic, total	8.5	4.5	6.5	26	-	46.4
Civil, total	12.5	7.5	10.0	40	-	71.4
Military, total	4.5	3.5	4.0	16	-	28.6

- Notes: 1) Above is applicable to "summer staffing" and 4 watch teams. Additional staff is required for vacations and sickness leaves.
2) All other ATS Units in Iceland fall under the category "Domestic, Civil".

Source: Ref. 18

E.5.2 Staff Composition

Most of the Icelandic air traffic controllers received their ATC training in Iceland. However, some of them have attended ATC courses in the United States, and a total of 18 received radar training in the United Kingdom. The average age of the ATS staff currently employed at Reykjavik, including the chief controllers and ATS assistants, is 37 years (average age of the air traffic controllers is 43), and their average length of service in ATS is 13 years (18 years for the air traffic controllers alone).

APPENDIX F

SONDRESTROM FIC--SUPPLEMENTARY DESCRIPTIVE DATA (Excerpts from a Report by DCA, Denmark)

F.1 Information Source

This appendix consists of selected excerpts quoted directly from "A Brief Description and Summary of Problems in Sondrestrom FIR (Below FL195)" (ref. 11) prepared by the Directorate of Civil Aviation, Denmark. The quoted material is indicated by the indented text in the remainder of this appendix.

F.2 Airspace Structure

Below FL195, Sondrestrom Flight Information Center is responsible for the provision of Flight Information Service outside controlled terminal airspace. The responsibility for Air Traffic Control within Thule and Sondrestrom TMA's rests with the USAF. The control units (TWR and APP) at these locations are staffed by USAF personnel. Above FL195 and north of 63:30N, the responsibility for ATC is delegated to Reykjavik OAC; south of 63:30N the responsibility is delegated to Gander OAC.

The following ATS routes have been established:

- FW 20, From Thule VOR along west coast of Greenland to Narssassauq.
- FW 27, From position ALFA south of Thule VOR along west coast to Simiuataq NDB west of Narssassauq.
- FW 28, From Holsteinsborg NDB via Sondrestrom NDB across the ice cap to Kulusuk Airport on the east coast.
- FW 36, From Cook Islands NDB on west coast via Sondrestrom Airport across the ice cap to Mestersvig Airfield on the east coast.
- FW 37, A short feeder route from Simiuataq NDB to Narssassuaq Airport.
- FW 38, From Sondrestrom NDB via SOB STORY radar station to Kulusuk on the east coast.

These routes are intended for use by internal flights. The routes have been published to simplify navigation and search and rescue activities. The Danish CAA is considering some changes to the airspace structure. The most frequently used portions of the FW-routes will probably be upgraded to Advisory routes, and the remaining airspace will keep its present status.

F.3 ATS Operations--Special Problems

F.3.1 General

Sondrestrom FIR is an enormous area with extremely low population density. The total population of Greenland (2,176,000 sq km) is only approx 50,000 and this small number is concentrated in the west and south-east coastal areas (approx pop 48,000). The interior and the coastal areas in the north-east and north are absolutely deserted except for the weather stations, the DEW-line radar stations and a dog sleigh patrol to keep Danish sovereignty.

F.3.2 Communications (Air/Ground)

Along the west coast almost all passenger transportation is by air. At present this is mostly by Sikorsky S-61 and S-58 helicopters, but fixed wing aircrafts (Twin Otter and DHC-7) are gradually being introduced. One STOL-airport (Godthab) is under construction, and four (Egedesminde, Frederikshab, Holsteinsborg and Jakobshavn) are planned for the near future.

Today, most operations are VFR, due to the strict limitations on IFR helicopter operations. However, IFR operations for helicopters are being implemented within a short time.

With the increase in IFR operations, both fixed wing and helicopter, the need for controlled airspace, or at least advisory airspace will increase. This will cause problems within the Sondrestrom FIR, because radio communications are at times severely restricted. Because of the high latitudes, problems with aurora borealis on HF are common. VHF is very limited at low altitudes due to the extremely mountainous terrain. Some remote VHF stations are established along the west coast with remote control from Godthab, Egedesminde and Julianehab A/G stations. To expand this system to cover the whole west coast with central remoting from Sondrestrom would be very costly due to the number of control circuits necessary.

F.3.3 Communications (Ground/Ground)

Sondrestrom Flight Information Center is almost 100% depending on the USAF for its outside communications. The USAF has the right to terminate the present communication agreements. A Danish government agency, the Greenland Technical Organization (GTO), is at present reviewing a complete communication plan for Greenland. Almost all settlements

are to be equipped with small community satellite receivers and transmitters. This will greatly improve the internal communication possibilities, and also give new possibilities for external communication links. The full consequences and possible uses for the aviation community have not yet been evaluated.

F.3.4 Navigation

Navigational accuracy is far below par unless OMEGA/VLF or INS navigation systems are used. With the exception of the single VOR at Thule, the only local navaids for civil aircraft are NDBs. The NDBs are frequently disturbed by static and the propagation patterns can be very erratic. The scarcity and unreliability of both navaids and communication channels are causing problems for the Air Traffic Services. Missing position and normal operation reports are quite common and are causing daily frustrations and anxiety as RCC will be activated and Uncertainty phase (INCERFA) declared. Navigational inaccuracies cause aircraft to be overdue, and puts unnecessary strain on all parts of the ATS system.

F.3.5 Search and Rescue

The large area and the scarcity of population means that in almost all cases, actual rescue missions will have to be accomplished by air. The number of aircraft permanently stationed in Greenland is low, and none are solely dedicated to SAR. One C-130 of the Danish Air Force is able to make long-range SAR-missions and drop supplies. The helicopters of Greenland air can be utilized, and some of them are equipped with rescue hoists. The number and availability of USAF aircrafts are varying as none are permanently stationed in Greenland. The insufficient number of readily available aircraft will make an expeditious SAR-action, especially in the east and north, almost impossible.

F.3.6 General Aviation Flights

The general aviation flights passing through Sondrestrom FIR to/from Europe/North America are of some concern, as these flights are often marginally equipped with radio and navigation systems. This, coupled with the fact that the area around the southern tip of Greenland can have fast changing weather systems, causes anxiety for the safe conduct of these flights. Furthermore, in 1976 on a LIM NAT meeting (ICAO DOC. 9182, Rec. 1.1/7) it was recommended that general aviation flights should follow certain tracks across the North Atlantic. Both recommended tracks are passing through

Sondrestrom FIR, and as more general aviation flights will follow these tracks in the future, it is expected that the problems now encountered with general aviation flights in Gander and Prestwick Oceanic Airspace, will be passed on to Sondrestrom.

F.4 Staffing

As the FIR airspace below FL195 is uncontrolled airspace, no trained air traffic controllers are employed in Sondrestrom FIC, except one acting as unit chief.

Personnel:

Sondrestrom FIC: 1 Air traffic controller (Unit Chief)
8 FIC-operators.

F.5 Finance and Costs

The ICAO document JS/WP 1070 is the latest audited report on the costs of air navigation services in Greenland. This report contains all material concerning joint finance. The figures in this report for Sondrestrom Radio, HF, does include the operation of VHF. As joint financing of Sondrestrom radio will be terminated July 1st 1979, Denmark is considering the implementation of a communication charge to all international flights using this station. The planned communication charge is expected to be approximately D. kr. 300 per flight. Enclosed is also a brief summary on the costs of operating Sondrestrom FIC in 1977:

Cost Item	1977 Direct Expenses, Danish Kroner (Ave Exchange rate, 1978: D kr. 5.5146 = US\$1)	
Salaries:		
Basic salaries	540,000	
Allowances	106,800	
Overtime	225,500	Subtotal: 872,300
Food & Housing	343,000	Subtotal: 343,000
General expenses		
Stationery & misc.	2,700	
Rent of facility area & utilities	208,000	Subtotal: 210,700
Transportation		
Personnel	18,000	
Freight	25,400	Subtotal: 43,400

Maintenance			
Buildings		0	
Vehicles		14,900	
Office and housing equipment		7,300	Subtotal: 22,200

Total: 1,491,600

Due to the very limited and the high cost of housing, some of the employees are permanently living at the Airport Hotel. For the rest, housing is highly subsidized. This is the explanation for the very high amount used on Food and Housing.

The costs of operation of non-joint-financed meteorological services, navigational aids and communication services are not included as they are very hard to specify. The meteorological observation stations are partly paid for by the Danish Meteorological Services and partly by the Greenland Technical Organization. The costs of operation of navigational aids are distributed among several agencies. Equipment installed at Thule and Sondrestrom AF Bases are paid for by the USAF. The NDBs are either operated by the Danish Adm. of Navigation and Hyrdography or the Greenland Technical Organization. As these beacons also serve shipping, the actual costs to aviation are not determined. Communication stations are operated and manned by the Greenland Technical Organization. The aviation communication stations and the public communication stations are often integrated operationally. Often these communication stations are the only link to the outside world for long periods, and consequently they would have existed with or without aviation in the area. Consequently, actual costs to aviation are not known as they are contained within the total communication costs for Greenland. All outside telephone circuits are via DEW/DYE line communication system. No charge is made by the USAF for use of any of its communication circuits.

APPENDIX G
SAN JUAN ACC--SUPPLEMENTAL DESCRIPTIVE DATA

G.1 Information Source

This appendix is based on an observational visit to the San Juan ACC in June 1979 and subsequent consultations with San Juan ACC personnel.

G.2 Airspace Structure

The oceanic and adjacent airspace responsibilities of the San Juan ACC include the oceanic airspace above FL25 shown in Figure G-1. The ACC is an FAA Combined En route and Radar Approach and Departure (CERAP) facility and controls domestic and oceanic airspace. Sectors 1 and 5 cover nonradar oceanic airspace and operate, respectively, in coordination with Sectors 2 and 4; the latter are provided with radar coverage but also include nonradar oceanic airspace. The oceanic jurisdiction includes the airspace at and above FL25, while the domestic jurisdiction (except for terminal transition) includes FL20 and above.

The part of the San Juan ACC's airspace relevant to the NAT as distinguished from domestic and Caribbean airspace, covers the air traffic flying into and out of the previously identified NAT jurisdictions. These jurisdictions include the New York and Santa Maria ACCs as well as the part of the Miami ACC that handles air traffic flying between the New York and San Juan ACCs. Therefore, the San Juan NAT oceanic CTA/FIR includes: Sector 1 east of, but not including, ATS route A17; all of Sector 5 including the "deep ocean" airspace east of 60 W; and the nonradar part of Sector 4 interfacing with Sector 5. This airspace includes route B14 in Sector 1 which passes into the Miami ACC and, subsequently, the New York ACC airspaces; routes A20, A21, A22, A23 and A25 in Sector 5; and oceanic random tracks through Sectors 1, 4 and 5. Military reservation areas (not shown in Figure G-1) are selectively activated in San Juan's NAT oceanic CTA/FIR.

G.3 General Accommodations

Figure G-2 shows the current control room layout for the San Juan ACC. The data and assistant control positions (i.e., D2, A2 and D4, A4) associated with the en route radar sectors provide the oceanic ATS services for Sectors 1 and 5. The clearance delivery (CD) and flight data (FD) positions support oceanic and domestic operations. The latter include the arrival (AR) and departure (DR) positions for Puerto Rico traffic, low-altitude en route satellite (SAT) positions for local traffic (St. Thomas, St. Croix, Roosevelt Roads), and associated coordination and support positions.

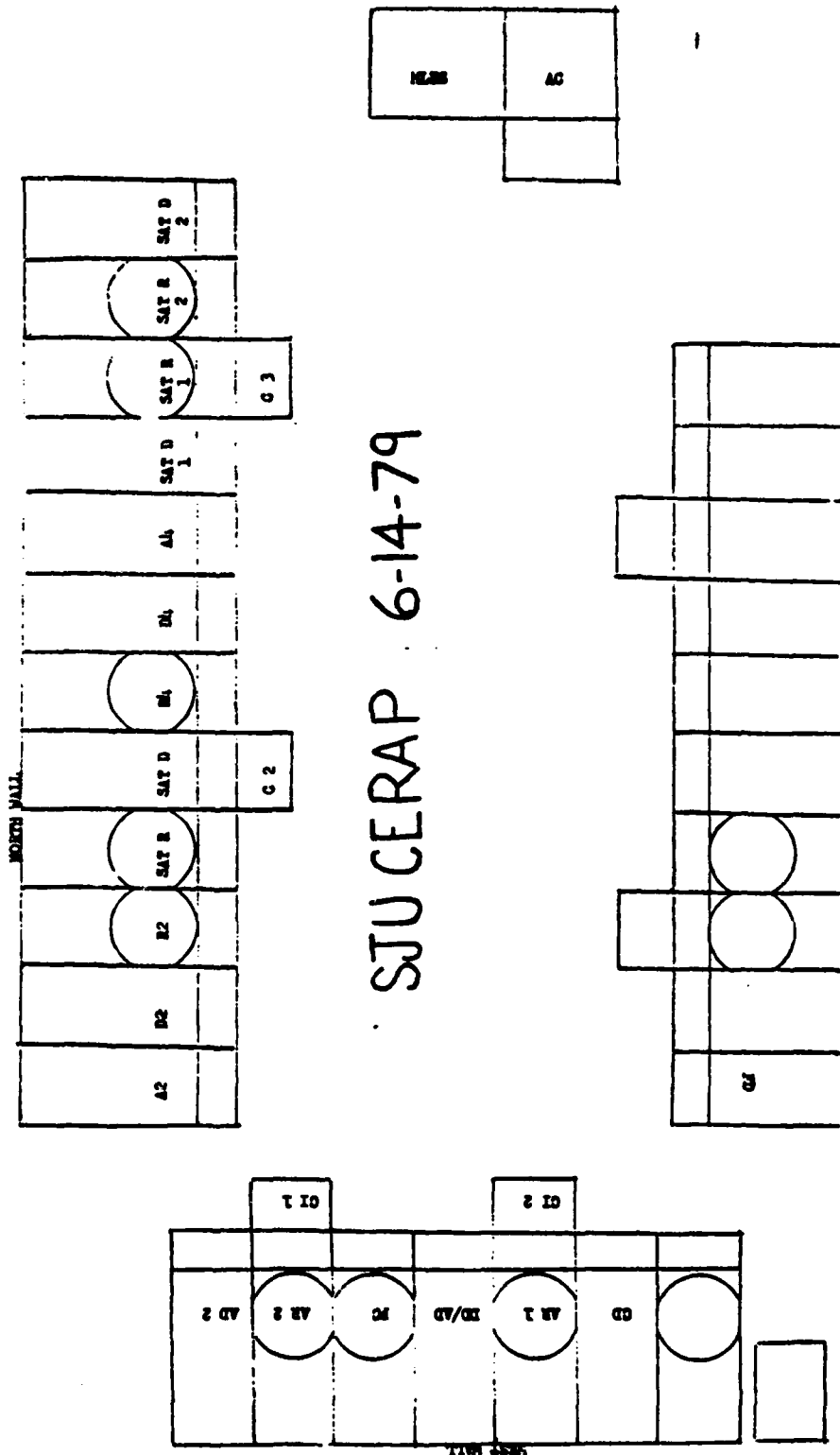

Source: San Juan ACC

FIGURE G-2. SAN JUAN ACC CONTROL ROOM

G.4 Operational Procedures

NAT air traffic to and from North America generally fly on the ATS routes, while traffic to and from Europe and Africa fly on random tracks. Aircraft outbound from Puerto Rico are issued oceanic clearances from the CD positions as determined by the oceanic controllers. The latter coordinate clearances with the New York, Santa Maria and Miami ACCs as well as with local terminal sector controllers. Tactical clearance procedures are used which enable the issuance of altitude changes as part of the oceanic clearance. For example, an aircraft bound to Europe may be issued a clearance with a crossing restriction at 26 N to assure that the aircraft is level when entering the New York CTA/FIR at 27 N at the altitude required by the New York ACC.

San Juan ACC personnel report that aircraft from Caribbean locations destined to Europe and passing through the San Juan CTA/FIR may have difficulty in receiving their desired flight levels before they enter the deep ocean airspace. For example, a flight from Kingston to London must cross numerous north-south ATS routes and could be diverted to a flight level under the crossing traffic until clear of the ATS routes. Flights in the deep ocean are manually plotted and tracked to check separations. Oceanic flights (i.e., ATS route and random track aircraft) are monitored by means of manual flight strip updates based on HF position reports.

APPENDIX H
MIAMI ACC--SUPPLEMENTAL DESCRIPTIVE DATA

H.1 Information Source

This appendix is based on observations of Miami ACC operations in June 1979 and subsequent consultations with Miami ACC personnel.

H.2 Airspace Structure

The domestic and oceanic airspace responsibilities of the Miami ACC are shown in Figure H-1 which shows that a part of Sector 72 covers the high altitude airspace used by NAT air traffic and a part of Sector 71 covers low altitude airspace. This traffic flies to and from the adjacent New York CTA/FIR on ATS routes A15, A18, B26 and B14; the B14 route handles traffic passing through the Miami CTA/FIR into and from the San Juan CTA/FIR. The airspace in Sector 72 southwest of and exclusive of B14 is considered part of the Caribbean region and is not included in the NAT.

H.3 General Accommodations

Figure H-2 shows the control room layout for the Miami ACC. The Sector 72 data (D72) position, with support of the assistant (A72) position, is responsible for oceanic ATS operations. The D72 position extensively coordinates by interphone with the Sector 81 radio or radar (R81) and data (D81) positions and with the adjacent oceanic ACCs regarding NAT traffic movement.

H.4 Operational Procedures

Radar coverage from the mainland extends to the vicinity of the RESIN fix while VHF A/G communication coverage extends into the coastal and interisland airspace. Neither radar surveillance nor VHF communication service is provided in the NAT airspace at Sector 72, and flight monitoring is based on HF position reporting and flight strip updating procedures.

The D72 position determines clearances for aircraft entering the oceanic airspace. Clearances for northbound flights on A15 and B26 (most of which are headed to northeast North America and Bermuda) are transmitted to the Sector 81 positions for VHF relay by R81 to the pilots. Clearances for aircraft inbound to Sector 72 from the New York and San Juan ACC's airspace are coordinated with these units, as are outbound clearances. Clearances for southbound flights on the heavily used A18 route take into account the B26 traffic crossing at the LEARS fix and the heavy interisland traffic which crosses A18 at the Grand Turk fix (MKJT).

Lateral separation routinely used by the Miami ACC in airspace is 100 nmi, which differs from the 90 nmi and 120 nmi used, respectively, on ATS routes and random tracks by the New York ACC. The more critical minima is applied when coordinating oceanic clearances between the units.

APPENDIX I

NAT REGION SEPARATION STANDARDS (Excerpts from ICAO Doc. 7030)

I.1 Information Source

The rules of the air, air traffic service, and search and rescue established by international agreement for specific regions are defined in ICAO DOC 7030/2 "Regional Supplementary Procedures" (ref. 4). The Supplementary Procedures (SUPPS) describe the operational procedures developed by Regional Air Navigation (RAN) meetings to define the rules of operation in each region not covered in the worldwide provisions published in ICAO annexes and related documents. Specifically, the procedures are supplementary to the general provisions contained in the following ICAO publications: Annex 2 (ref. 2), Annex 11 (ref. 1) and the "Procedures for Air Navigation Services, Rules of the Air and Air Traffic Services" (PANS-RAC) DOC 4444-RAC/501 (ref. 3).

This appendix consists of excerpts quoted directly from selected sections of Part 1 of Doc 7030/2 describing separation standards for the NAT region. These rules do not apply in the local areas established by the appropriate ATS authorities around Bermuda, Iceland, the Faroe Islands, Santa Maria, and in Greenland.

I.2 NAT Separation Minima Specifications

The paragraphs ("para.") described below refer to the paragraph numbering system used in Part 1 DOC 7030/2; Part 1 is "Rules of the Air, Air Traffic Services and Search and Rescue" (SUPPS-RAC). Paragraphs in DOC 7030/2 that do not apply to the NAT region are excluded from the following excerpts of supplementary procedures as is evidenced by the purposely "missing" paragraph numbers in the following text. The excerpted material is indicated by indented text in the remainder of this appendix.

Para. 1--Minimum Navigation Performance Specifications
(MNPS)

Para. 1.1--Methods of Application

Para. 1.1.1 Aircraft used to conduct flights within the volume of airspace specified in Para. 1.2.1 shall have navigation performance capability such that:

- a) The standard deviation of lateral track errors shall be less than 6.3 NM (11.7 Km);

- b) The proportion of the total flight time spent by aircraft 30 NM (55.6 Km) or more off the cleared track shall be less than .00053;
- c) The proportion of the total flight time spent by aircraft between 50 and 70 NM (92.6 and 129.6 Km) off the cleared track shall be less than .00013.

Such navigation performance capability shall be verified by the State of Registry or the State of the Operator, as appropriate.

Para. 1.1.2 "Adequate monitoring of flight operations in the NAT Region shall be conducted in order to assist in the assessment of continuing compliance of aircraft with the MNPS.

Note: Monitoring will be conducted in accordance with the appropriate guidance material issued by ICAO.

Para. 1.2--Area of Applicability

Para. 1.2.1 The MNPS shall be applicable in that volume of airspace between FL275 and FL400 extending between latitude 27 degrees N and latitude 67 degrees N, bounded in the East by the Eastern boundaries of FIRs Santa Maria Oceanic, Shanwick Oceanic and Reykjavik and in the west by longitude 60 degrees W within FIR New York Oceanic, the western boundary of FIR Gander Oceanic and the western boundary of FIR Reykjavik.

Note: This volume of airspace will be referred to as the MNPS airspace.

Para. 2--Separation of Aircraft

Para. 2.1--Lateral Separation

Para. 2.1.1 Minimum lateral separation shall be:

- 1) a) 60 nautical miles between supersonic aircraft operating at or above FL480;
- b) 90 nautical miles between turbojet aircraft operating within the control areas of Gander Oceanic, New York Oceanic, Reykjavik, Santa Maria Oceanic, Shanwick Oceanic and Sondrestrom (south of 70 degrees N); and
- c) 120 nautical miles between other aircraft.

Para. 2.2--Longitudinal Separation

Para. 2.2.1 Minimum longitudinal separation shall be:...

- 4) a) 10 minutes between aircraft in supersonic flight provided that
- i) both aircraft are in level flight at the same Mach number or the aircraft are of the same type and are both operating in cruise climb;
 - ii) the aircraft concerned have reported over the same entry point into the oceanic controlled airspace with a time interval of at least 12 minutes and follow the same or continuously diverging tracks until another form of separation is established.

Note: An ATC clearance authorizing the commencement of the deceleration/descent phase of the flight of the aircraft concerned may be issued while the above separation minimum is being applied.

This separation minimum may also be applied between supersonic aircraft which have not reported over the same entry point into oceanic controlled airspace (but comply with all other provisions) provided their respective entry points, as well as the point from which they either follow the same track or start following continuously diverging tracks, are located within the radar coverage of the controlling ATC unit and it is therefore possible, by radar monitoring, to ensure that the appropriate time interval will exist between the aircraft concerned, at the time they start to follow the same or continuously diverging tracks;

- b) 15 minutes between aircraft in supersonic flight but not covered by 4 a) above;
- 5) a) 15 minutes between turbojet aircraft provided that the Mach number technique is applied and the aircraft concerned have reported over the same entry point into oceanic controlled airspace and follow the same track or continuously diverging tracks.

This separation may be reduced to:

- 10 minutes at the entry point into oceanic controlled airspace, if the preceding aircraft is maintaining a speed of at least Mach 0.03 greater than that of the following aircraft;

or

- 5 minutes at the entry point into oceanic controlled airspace, if the preceding aircraft is maintaining a speed of at least Mach 0.06 greater than that of the following aircraft;

The above separation minima may also be applied between aircraft which have not reported over the same entry point into oceanic controlled airspace (but otherwise comply with all other provisions) provided their respective entry points as well as the point from which they either follow the same track or start following continuously diverging tracks are located within the radar coverage of the controlling ATC unit and it is therefore possible, by radar monitoring, to ensure that the appropriate time interval will exist between the aircraft concerned at the time they start following the same or continuously diverging tracks.

- b) 20 minutes between:
 - i) turbojet aircraft not covered by 5 a) above:
 - ii) other than turbojet aircraft operating within the New York Oceanic control area, long routes extending between the United States, Canada or Bermuda and Caribbean terminals, or between the United States or Canada and Bermuda.
- 6) 30 minutes between other than turbojet aircraft, except those covered by 5 b) ii) above.

Note: The "Mach number technique" as stated in the ICAO PANS-RAC Doc 4444 (ref. 3), Part III, Para. 8.1, may be applied when so prescribed on the basis of regional air navigation agreement. Doc 4444, Appendix H, explains the technique as follows:

The term "Mach number technique" is used to describe a procedure whereby turbo-jet aircraft operating successively along suitable routes are cleared by ATC to maintain appropriate Mach numbers for a relevant portion of the en route phase of their flight, to which the aircraft are required to adhere within close tolerances in order to maintain longitudinal separation between them...

The ATC clearance must include the assigned Mach number which is to be maintained. It is therefore necessary that information on the desired Mach number relevant to any particular portion of the flight be included in the flight plans filed by pilots intending to operate along the routes in the area concerned...

It is essential that entry fix estimates provided by pilots should be accurate since they form the basis on which separation between aircraft is planned. Closest possible coincidence between the ATA (actual time of arrival) and the ETA (estimated time of arrival) previously given for the entry point is therefore of value. Radar surveillance in the transition area is desirable since it provides a means to assist accurate positioning of aircraft in this context.

When the Mach number technique is being used, the following procedures should be employed:

- (i) Aircraft must adhere to the ATC cleared Mach number within a tolerance of plus and minus 0.01.
- (ii) When considered necessary by the appropriate ATS authority, current Mach number must be included in routine position reports.
- (iii) Approval must be obtained from ATC prior to any change in cruise Mach number.

In addition, the approved Mach number should be included in any relevant coordination information passed between ATS units (ref. 13).

Para. 2.2.2

Para. 2.2 Turbojet aircraft operating within controlled airspace shall adhere to the Mach number approved by ATC within a tolerance of plus or minus 0.01 and shall request ATC approval before making any change thereto. If essential to make an immediate temporary change in the Mach number (e.g., due to turbulence), ATC shall be notified as soon as possible that such a change has been made.

c. Para. 2.4--Vertical Separation

Para. 2.4.1 Above FL450, vertical separation between supersonic aircraft, and between supersonic aircraft and any other aircraft, shall be considered to exist if the flight levels of the two aircraft differ by at least 4000 ft.

Para. 2.5.1 of ICAO Doc 7030/2 as copied above supplements the vertical separation minima specified in ICAO PANS-RAC Doc 4444 (ref. 3). The vertical separation minima are described as follows in Doc 4444:

Para. 3.1 (ICAO PANS-RAC Doc 4444, Part III) The vertical separation minimum shall be a nominal 300 meters (1,000 feet) below an altitude of 8,850 metres (29,000 feet) or flight level 290, and a nominal 600 metres (2,000 feet) at or above this level, except where on the basis of regional air navigation agreements a nominal vertical separation minimum of less than 600 metres (2,000 feet) but not less than 300 metres (1,000 feet) is prescribed for use under specified conditions, by aircraft operating above flight level 290 within designated portions of the airspace.

Table I-1 lists the cruising level assignments associated with hemispheric vertical separations.

Para. 2.5--Composite Separation

Para. 2.5.1 For turbojet aircraft operating at or above FL290 and within the organized track system when established within the Gander Oceanic, New York Oceanic, Reykjavik, Santa Maria Oceanic and Shanwick Oceanic control areas, composite separation, consisting of the combination of at least 60 nautical miles lateral and 300 metres (1,000 feet) vertical separation may be applied.

Para. 2.5.3 The type of separation in 2.5.1...may be applied between aircraft operating in the same or opposite directions.

Para. 2.1.6--Information on Application of Separation Minimum

Where, circumstances permitting, separation minima lower than those specified in 2.1 and 2.2 will be applied in accordance with the PANS-RAC, appropriate information should be published in Aeronautical Information Publications so that users of the airspace are fully aware of the portions of airspace where the reduced separation minima will be applied and of the navigational aids on the use of which those minima are based.

Para 4.6.1

When necessary in order to permit the optimum use of the airspace, the area control centres serving Gander and Shanwick Oceanic control areas may, subject to coordination with each other and, when appropriate, with the New York Oceanic, Reykjavik and Santa Maria Oceanic area control centers, apply an organized track system. The following procedures shall then be applied.

TABLE I-1

TABLE OF CRUISING LEVELS

The cruising levels to be observed when so required by Annex 2 (ref.2) are as follows:*

TRACK**											
Eastbound, Headings from 000° to 179°***						Westbound, Headings from 180° to 359°***					
IFR FLIGHTS			VFR FLIGHTS			IFR FLIGHTS			VFR FLIGHTS		
FL	ALTITUDE		FL	ALTITUDE		FL	ALTITUDE		FL	ALTITUDE	
	Metres	Feet		Metres	Feet		Metres	Feet		Metres	Feet
90						0					
10	300	1 000				20	600	2 000			
30	900	3 000	35	1 050	3 500	40	1 200	4 000	45	1 350	4 500
50	1 500	5 000	55	1 700	5 500	60	1 850	6 000	65	2 000	6 500
70	2 150	7 000	75	2 300	7 500	80	2 450	8 000	85	2 600	8 500
90	2 750	9 000	95	2 900	9 500	100	3 050	10 000	105	3 200	10 500
110	3 350	11 000	115	3 500	11 500	120	3 650	12 000	125	3 800	12 500
130	3 950	13 000	135	4 100	13 500	140	4 250	14 000	145	4 400	14 500
150	4 550	15 000	155	4 700	15 500	160	4 900	16 000	165	5 050	16 500
170	5 200	17 000	175	5 350	17 500	180	5 500	18 000	185	5 650	18 500
190	5 800	19 000	195	5 950	19 500	200	6 100	20 000	205	6 250	20 500
210	6 400	21 000	215	6 550	21 500	220	6 700	22 000	225	6 850	22 500
230	7 000	23 000	235	7 150	23 500	240	7 300	24 000	245	7 450	24 500
250	7 600	25 000	255	7 750	25 500	260	7 900	26 000	265	8 100	26 500
270	8 250	27 000	275	8 400	27 500	280	8 550	28 000	285	8 700	28 500
290	8 850	29 000	300	9 150	30 000	310	9 450	31 000	320	9 750	32 000
330	10 050	33 000	340	10 350	34 000	350	10 650	35 000	360	10 950	36 000
370	11 300	37 000	380	11 600	38 000	390	11 900	39 000	400	12 200	40 000
410	12 500	41 000	420	12 800	42 000	430	13 100	43 000	440	13 400	44 000
450	13 700	45 000	460	14 000	46 000	470	14 350	47 000	480	14 650	48 000
490	14 950	49 000	500	15 250	50 000	510	15 550	51 000	520	15 850	52 000
etc.	etc.	etc.	etc.	etc.	etc.	etc.	etc.	etc.	etc.	etc.	etc.

- * Except when, on the basis of regional air navigation agreements, a modified table of cruising levels based on a nominal vertical separation minimum of less than 600 metres (2 000 feet) but not less than 300 metres (1 000 feet) is prescribed for use, under specified conditions, by aircraft operating above flight level 290 within designated portions of the airspace.
- ** Magnetic track, or in polar areas at latitudes higher than 70° and within such extensions to those areas as may be prescribed by the appropriate ATS authorities, grid tracks as determined by a network of lines parallel to the Greenwich Meridian superimposed on a polar stereographic chart in which the direction towards the North Pole is employed as the Grid North.
- *** Except where, on the basis of regional air navigation agreements, from 090° to 269° and from 270° to 089° is prescribed to accommodate predominant traffic directions and appropriate transition procedures to be associated therewith are specified.

Source: Annex 11 to the Convention on International Civil Aviation, Seventh Edition, ICAO, April 1978 (ref.1)

Para. 4.6.1.1

Operators conducting scheduled or non-scheduled flight operations within Gander Oceanic, Santa Maria Oceanic (north of 37 degrees N) and Shanwick Oceanic control areas shall provide information to the oceanic area control centers concerned regarding the tracks likely to be requested by turbojet aircraft during the peak traffic periods. Such information shall be provided as far in advance of the anticipated peak periods as practicable or at such time(s) as have been specified in appropriate aeronautical information publications. Messages containing the information shall be addressed to Gander and Shanwick Oceanic area control centers and, concerning tracks in the area between 37 degrees N and 45 degrees N in the Santa Maria Oceanic control area also to the Santa Maria Oceanic area control center.

Para. 4.6.1.2

The area control centers concerned shall, when applicable, disseminate to operators information regarding the ATC tracks established, together with such other information as may be considered useful by the operator for correct assessment of the track system. Such information shall be disseminated three hours in advance of each anticipated peak traffic period. Any subsequent change made to the track structure shall be notified to the operator as soon as practicable.

Para. 4.6.2

Appropriate notification of intended reclearances involving flight levels and/or re-routing of aircraft should be made to the aircraft and/or the operator concerned as soon as practicable. The notification to the operator shall be made in accordance with Annex 11, paragraph 2.1.1.

Para. 4.6.3

When composite separation is used in the organized track system, the following procedures shall apply:

- 1) Aircraft may be cleared to join the outer track of the organized track system at points other than the normal entry points in the oceanic control areas provided required minimum longitudinal or vertical separation will exist between such aircraft and others operating along this track. The clearance shall, however, provide that joining shall be effected via a track extending between the point of joining and a point which, at 10 degrees of longitude from the joining point, is laterally not less than 60 NM and not more than 120 NM distant from the track in question.

- 2) Aircraft flying along the outer track of the organized track system may be cleared to leave the system provided that the separation from all other aircraft in the system continuously increases until another form of separation is established.
- 3) Aircraft changing tracks within the organized track system or which are crossing the organized track system shall be cleared to do so only if they are provided with minimum longitudinal, lateral or vertical separation with respect to other aircraft;
- 4) Aircraft operating in the organized track system may be cleared to change levels on the same track.

f. Para 4.8--Establishment and Use of Organized Tracks
for Supersonic Aircraft Operations

Para. 4.8.1

Where appropriate, an organized track system may be promulgated for supersonic aircraft operations. When promulgating such an organized track system the requirements for position reporting and the applicability of abbreviated position reports shall be included.

APPENDIX J

METEOROLOGICAL DATA AND METHODS USED IN GENERATING THE AVIATION DIGITAL FORECAST

(B. Mancuso, P. Loats, SRI International)

J.1 Introduction

One of the many services provided by the National Weather Service (NWS) of the United States is the aviation digital forecast (ref. 19, 20). These forecasts are tailor-made for airlines, covering most of the globe with wind and temperature data. This appendix describes the basic process of generating the aviation digital forecast. It traces the process from data collection, through analysis and prediction, to dissemination of the final product.

J.2 Meteorological Observation

Three measurement sources provide the information gathered for the aviation digital forecast: radiosonde, aircraft, and two types of satellites that cover most of the globe.

The principal upper-air measurement of the current meteorological observation system is the radiosonde. This upperatmospheric sounding device which has an altitude range of approximately 30 km consists simply of a balloon and a suspended instrument package. The instrument package carries pressure, temperature, and humidity sensors, plus a radio transmitter to relay the data gathered back to the ground station. The readings of temperature and humidity are gathered at intervals determined by the pressure gauge.

Winds aloft are calculated at the surface by radiotheodolite tracking. The radiotheodolite is a ground level device which detects the arrival directions of incoming radio waves that are transmitted from the radiosonde, and provides two of the three coordinates required for an estimated radiosonde position. The tracking system needs an independent measure for its third coordinate. Normally, this is provided by temperature and pressure measurements that are used to derive a measurement of height. However, some tracking systems (e.g., ranging radiotheodolites) are capable of measuring the time it takes a signal to reach the balloon and return, giving a true distance for computation with the angular measure. This latter system while accurate, is expensive and is used only when high winds are expected.

Radiotheodolite measurements provide balloon position reports at a sampling rate of 1 per min, which is equivalent to the data rate requirement for wind estimates. In the computation of the wind vectors at the station locations, the earth is assumed to be a perfect sphere and the balloons are assumed to follow great-circle paths between samples. Spherical trigonometry is used for the wind-speed calculations, whereas plane trigonometry is all that is needed to compute wind direction. At the NWS stations, the winds are now being derived using a minicomputer system.

There are approximately 500 radiosonde launch sites worldwide. At half of these stations one balloon a day is released; at the other half a balloon is released twice daily, and a few stations make soundings every 6 hr. In 1972, the United States eliminated the moving ship sounding program and cut back on the number of stationary ocean vessels used for balloon launchings. This greatly reduced the number of grid points covered by the radiosonde collection network in the North Atlantic and North Pacific oceans. The lack of ocean radiosonde sites is of some significance because measurement and analysis errors are of lesser importance than are spatial sounding gaps for weather prediction. These gaps have to some extent been filled by AIREP meteorological information.

The AIREPs provide information on winds and temperatures, along with visual reports of local weather (e.g., clouds and clear air turbulence). These flight data are quite numerous but are most frequently obtained in the major air traffic corridors and at common subsonic turbojet aircraft altitudes between 300 and 200 mbar. Over the North Atlantic, AIREPs are gathered as part of the Aeronautical Broadcast Service, provided by the Gander COM station. This service deals exclusively with transmitting and receiving weather to and from aircraft in the Gander CTA. One aircraft per hour per track is designated to send AIREPs. AIREPs are collected only from aircraft equipped with Inertial Navigational System (INS); for example, Boeing 747, Lockheed L1011, and the Air Force C5 and C141. In the Pacific region, all AIREPs go to the Fleet Weather Central in Honolulu, where they are analyzed by Navy, Air Force and NWS meteorologists. The data basically is accurate but significant errors can be introduced by garbled voice transmissions.

The third upper-air data source is the satellites. There are two types of satellites currently being used: the geostationary and the polar orbiting. Each of the geostationary satellites remain fixed at some location over the earth and cover a specific area of the globe. Through cameras and digital picture transmission techniques, they provide cloud imagery data twice hourly. This permits measurement of winds by cloud tracking and the measurement cloud growth rates. The cloud-tracked winds are determined either manually or automatically by tracking the cloud positions between image transmissions.

The polar-orbiting satellites, provide remote measurements of temperature and humidity profiles twice daily for the whole globe. Despite the large number of data points, this information is given little weight in the ADF products in comparison to radiosonde data. The satellite temperature-profile data have had little impact on forecast accuracies over areas where other data are available, but have been found to significantly improve forecasts over poor data and remote regions.

A global telecommunication system (GTS) is used to distribute the above-mentioned data to all nations. A principal feature of this GTS is a trunk circuit girdling the globe, connecting Washington, Tokyo, Melbourne, New Delhi, Cairo, Moscow, Prague, Offenback, Paris and Bracknell. There are many feeders from each of these hubs on the main trunk circuit.

J.3 Meteorological Analysis and Prediction

The basic daily weather forecasting of the United States is provided by the NWS's National Meteorological Center (NMC) at Suitland, Maryland. NMC forecasting is a two-step process involving analysis and prediction.

When observational data reaches the NMC they are first processed and edited, then computer analyzed to provide the initial state of the atmosphere for input to prediction models. The computer analysis principally consists of interpolating the initial data value at a network of regularly spaced grid points from the inputted raw data. The analysis is not simply an interpolation scheme, but also compares each point to its neighbors and to the closest forecast in time to identify unreasonable values. The constraints as to which values are correct are necessarily loose, erring in the direction of accepting a few bad observations at the cost of retaining all the valid ones.

After the state of the atmosphere is initialized, the various forecast models of the NMC are then run at the NMC computer complex. The forecast model used for extracting the aviation digital forecast product is the 7-level Primitive Equation Model (7L-PE). In general, all the models make use of a system of conservation laws for mass, momentum, and thermodynamics along with diagnostic relationships such as the equation of state and the hydrostatic equation. Since these equations are for continuous systems, the system is solved numerically by finite difference methods.

The product of these computations is a forecast of temperatures and winds, provided at different pressure altitudes. The 7L-PE forecasts are generated for both the northern and southern hemispheres twice daily for 24, 36, and 48 hr from data collected at 0000 and 1200 GMT, and once for 84 hr from data for 0000 GMT.

J.4 Aviation Digital Forecast

The aviation digital forecasts are derived from the 7L-PE forecast model outputs. It provides winds and temperatures over most of the globe at grid points spaced 5 degrees in longitude and 2-1/2 degrees in latitude (with exceptions being: 5 degrees by 5 degrees in the 10 S - 10 N, and 70 N - 75 N bands; 20 degrees in longitude and 10 degrees in latitude above 75 degrees N; and no coverage from 75 S to 90 S).

The aviation digital forecast is output in three altitudes roughly conforming to the requirements of:

Propeller aircraft--800, 700, and 500 mbar levels
Subsonic jet aircraft--400, 300, 250, and 200 mbar levels, and
high flying aircraft--150, 70 and 50 mbar levels.

The forecasts are further divided into bulletins, marsden-squares and subsquares. A bulletin is a collection of data over a wide geographic area, such as North America or the North Atlantic, and for one of the above altitude ranges. For example, to cover North America from ground level up requires three bulletins, NWS numbers 11, 21, and 31. The marsden square, or blockette, consists of all the data for one altitude category, lying in a 10 degree by 10 degree square. A subsquare is the individual grid point contained in the marsden square.

The aviation digital forecast is transmitted along dedicated wires to various processing centers where it is then distributed to various users such as airlines who utilize the data for flight planning and the Gander ACC who utilizes the data for OTS planning.

APPENDIX K

SELECTED OPERATIONAL SITUATIONS

K.1 General

The following paragraphs review some selected NAT operational situations considered relevant to system efficiency.

K.2 OTS Entry Congestion

The "packing" of preferred flight paths at OTS entry cause potential conflicts between aircraft requesting identical tracks and flight levels at nearly the same time. A study of the magnitude of diversions on westbound flights through the Shanwick CTA/FIR for 9 days in July 1978 was conducted by the UK (ref. 16). The study compared actual flight paths against requested flight paths and found that 66 to 75 percent of all flights in the OTS on each sample day were cleared as requested; that 92 to 99 percent of each day's OTS flights were cleared to within 60 nmi of their requested track or within 2,000 ft of their requested flight level; and that 1 to 8 percent of each day's OTS flights were diverted more than 60 nmi or 2,000 ft. Note that eastbound traffic was not analyzed and the above statistics do not apply necessarily to the eastbound diversions.

K.3 Step Climbs

A UK survey of a 7 day period in July 1978 found that only 9 to 20 percent of each day's traffic received step climb clearances as shown in Table K-1 (ref. 12). Although the percentage of step climb requests was not specified, one ATS expert unofficially estimated that roughly 30 percent of the aircraft may request altitude changes. An airline expert unofficially postulated that the altitude change request rate would be higher if the pilots experienced a higher percentage of step climb approvals.

Controllers reported that the typical elapsed time between the instant of a pilot's clearance request by A/G radio, and the instant a pilot acknowledges receipt of the step climb clearance (both indicated on the hard copy teletype message) is of the order of 5 to 10 min. The relay time would delay the time at which an aircraft would receive a clearance for a requested altitude climb. This situation is alleviated by pilots requesting step climbs sufficiently in advance so as not to be adversely impacted by a communications delay, provided controllers have the ability to know other aircraft positions.

TABLE K-1

SURVEY OF STEP-CLIMBS IN THE GANDER/SHANWICK CTA/FIRS, JULY 1978

<u>Date</u>	<u>Direction of Flights</u>	<u>Total Flights</u>	<u>Step-Climbs</u>	<u>Percent</u>
3 July 1978	Eastbound	238	22	9.6
	Westbound	223	23	10.3
4 July 1978	Eastbound	188	18	9.5
	Westbound	187	21	11.2
5 July 1978	Eastbound	201	42	20.9
	Westbound	202	17	8.4
8 July 1978	Eastbound	213	32	15
	Westbound	207	24	11.6
9 July 1978	Eastbound	216	20	9.5
	Westbound	202	19	9.4
11 July 1978	Eastbound	217	34	15.6
	Westbound	188	16	8.5
12 July 1978	Eastbound	206	30	14.5
	Westbound	196	14	7.1

The step climb request is complicated when the situation calls for interactive step climb requests where one aircraft may not climb until a higher aircraft has climbed. Typically, the controller cannot issue a second step climb until the first (higher) aircraft has reported leaving the initial altitude (or reports reaching the cleared altitude as in the case of the Shanwick OACC). In theory, controllers at some facilities (excluding the Shanwick OACC) may issue instructions to pilots to initiate climb procedures upon hearing altitude leaving reports from the higher aircraft. However, such procedures to ameliorate the effects of air-ground communications delay are not routinely carried out currently.

K.4 Aircraft Speed Differences

Cruise speed differentials between successive aircraft at the same flight level on a track are accounted for at entry to the track when oceanic clearance is issued. Speed differentials between nonmilitary aircraft (i.e., commercial and general aviation) are less significant than those between nonmilitary and military aircraft. For example, the data in Table K-2 are based on a survey of flight progress strips for flights in the OTS and its vicinity and shows that commercial and general aviation flights typically range in cruise speed from Mach 0.80 to Mach 0.85. Many military flights typically range from Mach 0.74 to 0.77 while others cruise at Mach 0.86. The data shows that speed differentials as great as Mach 0.10 could exist between military and commercial aircraft flying in the same airspace. Such differentials would require longitudinal spacings of about 55 min at entry on most OTS tracks and 60 min on longer OTS tracks south of Newfoundland so as to provide 15 min spacing at track exit. The impact on diversion and delay of a high mix of low speed military aircraft could be significant when considering that the nominal longitudinal separation is 15 min and that a commercial aircraft would not be allowed to follow a military aircraft at any point close to the nominal spacing. However, military aircraft account for only 4 percent of the air traffic in the NAT.

K.5 Random Track Crossings

Random track traffic is subject to various types of conflicts including: those involving random traffic attempting to join, cross or leave the OTS; conflicts between aircraft on random tracks; and conflicts involving random tracks crossing the ATS tracks in the New York CTA/FIR. The random track joinings and crossings are a problem because the intensity of traffic on the OTS often causes a random track aircraft to be diverted to tracks parallel but outside the OTS or to tracks below or above the OTS. Such diversions apparently occur with sufficient frequency to cause aircraft operators to routinely file flight plans for paths under the OTS even though such flight levels are not optimum. For example, an examination of flight progress strip data for July 1979 indicates that flights between Northern Europe and the Caribbean often file flight plans requesting FL290 for the trans-Atlantic flight segment crossing the OTS; FL290 normally is a suboptimal flight level in terms

TABLE K-2

TYPICAL FLIGHT CHARACTERISTICS, JULY 1979

<u>Aircraft Operator</u>	<u>Aircraft Basic Type</u>	<u>Typical Cruise Speed</u>	<u>Typical Altitude Range</u>
Airline	DC8, B707, BA15, VC10	Mach 0.80	FL310-FL390
Airline	DC10	Mach 0.82	FL320-FL390
Airline	L1011, B747	Mach 0.84	FL310-FL390
Airline	B747SP	Mach 0.85	FL330-FL450
General Aviation	DA10, G2, C500	Mach 0.80	FL410-FL430
Military	C141	Mach 0.74	FL350-FL390
Military	C135, C5	Mach 0.77	FL310-FL350
Military	VCTR, VLCN	Mach 0.86	FL410-FL430

of turbojet fuel burn efficiency. Flights between the Iberian Peninsula and Canada also have difficulties joining and crossing the OTS tracks, but such difficulties are alleviated somewhat when tributary tracks are designated that join the Iberian Peninsula with a southerly OTS track at midocean. Flights to and from Scandinavia have similar problems when flight conditions are such that their preferred tracks call for joining or crossing the northerly OTS tracks at midocean rather than using random tracks north of the OTS.

The UK study (ref. 16) of diversions to westbound flights through the Shanwick CTA/FIR for 9 days in July 1978 included an analysis of random track traffic. The study found that 65 to 79 percent of random track flights on each sample day were cleared as requested; that 84 to 98 percent of each day's random track flights were cleared to within 60 nmi of their requested track or within 2,000 ft of their requested flight level; and that 2 to 16 percent of each day's random track flights were diverted more than 60 nmi and 2,000 ft.

APPENDIX L

ATS ANNUAL COST CALCULATIONS

L.1 Shanwick OACC Annual Costs

The following annual operations and maintenance costs for oceanic ATS at the Shanwick OACC during the fiscal year ending on March 31, 1978, are reported by the CAA, UK (ref. 21):

Expenditure Item	1978 Pounds Sterling (000)
(1) Staff costs	1985
(2) Services and materials	999
(3) Repairs and maintenance	93
(4) Research and development	43
(5) Depreciation and amortization	60
(6) Other operating and general expenditures	176
Total	3356

For the purpose of enabling a comparison of costs among units, the above listed costs are grouped according to the categories shown below:

Expenditure	1978 Pounds (000)	1978 US\$ (000)	1979 US\$ (000)
Staff Cost	1985	3810	4191
Other Direct Operating Costs	1180	2265	2491
Indirect Operating Cost	191	367	404
Total	3356	6442	7086

Note (1): 1978 Average Exchange Rate = US\$ 1.9195 per Pound Sterling (ref. 22).

Note (2): Assumed 1978 to 1979 inflation rate = 10 percent.

The staff cost category corresponds directly to item (1) above. The other direct operating cost category includes items (2), (3), and one-half of (6) listed above, while the indirect cost category includes the remaining cost items listed above. Item (6) is distributed between the direct and indirect cost categories because it is assumed to include interest and insurance payments (i.e., indirect expenses) as well as direct expenses.

The expenditures are converted from 1978 pounds sterling to 1979 U.S. dollars using the 1978 exchange rate and the annual inflation rate noted above.

L.2 Gander ACC Annual Costs

Transport Canada estimates that the total annual costs for domestic and oceanic ATS at the Gander ACC for the fiscal year ending March 1979 is 8148.9 thousand Canadian dollars (ref. 23). This cost is for the operations and maintenance of the center and includes the following items: personnel (salaries and fringe benefits for operations and maintenance personnel); goods and services (materials for operations and maintenance); building rental (a cost per square foot established for Transport Canada buildings); overhead (65 percent of personnel and goods and services); depreciation (1/15 of the purchase cost of equipment); interest (8 percent of the book value of the item for the year in question); and equipment rental (such as communication circuits) (ref. 23).

Transport Canada estimates (ref. 10) that 75 percent of the total ACC manpower is allocated to oceanic operations. The application of this allocation factor to the total costs together with the application of the monetary exchange rate and annual inflation rate noted below provides the following annual cost estimates:

1978 Domestic and Oceanic ATS Annual Cost	=	8148.9	1978 CAN\$ (000)
1978 Oceanic ATS Annual Cost	=	6111.7	1978 CAN\$ (000)
	=	5358.1	1978 US\$ (000)
1979 Oceanic ATS Annual Cost	=	5894	1979 US\$ (000)

Note (1): 1978 Average Exchange Rate = US\$ 0.8767 per CAN\$ (ref. 22).

Note (2): Assumed 1978 to 1979 inflation rate = 10 percent.

A detailed breakdown of the total ATS cost is not available. Because the Gander ACC is similar in operational scope to the Shanwick OACC, the Gander ACC annual cost is assumed to be distributed among expenditure categories in the same proportions as that of the Shanwick OACC:

Expenditure	1979 US\$ (000)
Staff Cost	3486
Other Direct Operating Cost	2072
Indirect Operating Cost	336
Total	5894

L.3 New York, San Juan and Miami ACC Annual Costs

L.3.1 Staff Cost Estimates

Informal estimates of the oceanic controller staff (including supervisory and control personnel) were made by the FAA and resulted in 80, 33 and 65 persons, respectively, at the New York, San Juan and Miami ACCs. All of the New York ACC oceanic control staff are involved in NAT operations, while the San Juan and Miami ACC's oceanic staff are involved in NAT and CAR operations. Because detailed descriptions of the NAT versus CAR staffing are not available, each ACC's staff is allocated in proportion to rough estimates of the traffic through the NAT and CAR regions as follows.

At the San Juan ACC, one of two oceanic sectors handles NAT and CAR traffic; the other oceanic sector is entirely in the NAT region. About 30 percent of the first sector's traffic accounts for the NAT services provided in this sector. Given that 100 percent of the second sector's services are for NAT traffic, 65 percent of the 33 control personnel at the San Juan ACC are allocated to NAT operations.

At the Miami ACC, two of five oceanic sectors handle NAT and CAR traffic; the other three sectors are in the CAR region. About one-third of the traffic through the two sectors account for the NAT services provided by the ACC. Because the two sectors are 40 percent of the Miami ACC's oceanic sectors, 13 percent of the 65 control personnel are allocated to NAT operations.

The following data summarizes the NAT controller staffing allocations and associated annual costs assuming an average annual wage per person of 30 thousand 1979 U.S. dollars:

Unit	NAT Controller Staff (persons)	Controller Staff Cost 1979 US\$ (000)
New York ACC	80	2,400
San Juan ACC	21	630
Miami ACC	8	240
Total	109	3,270

In addition to the controller staff, the staff of the FAA units include ATC support and maintenance personnel. Detailed descriptions of the complete oceanic staff at each facility are not available, and staff allocations to NAT operations are made as follows. An FAA domestic en route center typically employs about 100 ATC support personnel, and 120 maintenance personnel, and typically is responsible for 30 to 35 domestic and oceanic sectors. Therefore, roughly 6.7 persons per sector (exclusive of controller staff) are employed. However, the oceanic

sectors are not equipped with radar and A/G communication services and require considerably less support and maintenance than the domestic sectors. A first-cut estimate of 2 noncontroller persons per oceanic sector is used to account for the lower level of support and maintenance complexity of the oceanic sectors relative to domestic sectors.

The New York ACC has 5 oceanic sectors, all of which are assigned to NAT operations. Based on the discussions given above, the San Juan ACC is allocated the equivalent 1.3 sectors for NAT operations. The Miami has 2 oceanic sectors of which one-third of each are allocated to the NAT. Assuming 2 persons per sector and an average annual wage per person of 30 thousand 1979 U.S. dollars, the estimated noncontroller staffing costs are:

Unit	Number of NAT Oceanic Equivalent Sectors	NAT Noncontroller Staff (persons)	Noncontroller Staff Cost 1979 US\$ (000)
New York ACC	5.0	10.0	300
San Juan ACC	1.3	2.6	78
Miami ACC	0.67	1.33	40
Total	6.97	13.93	418

L.3.2 Other Direct Operating Cost Estimates

The following costs of operating and maintaining a single oceanic sector are based on informal discussions with the FAA:

Oceanic Sector Cost Element	Direct Operating 1979 US\$ (000)
Spare parts and supplies	3
Key equipment (Telco)	10
Leased lines	10
Miscellaneous items	2
Total	25

The above list includes costs allocated to interphone communications between FAA domestic and oceanic sectors. Costs for international interfacility oceanic communications are not included in the above list but are treated as part of the COM system cost and estimated separately from ATS costs. The nonstaff direct operating costs estimated for each FAA ATS unit based on 25 thousand 1979 U.S. dollars per oceanic sector are:

ATS Unit	Number of NAT Oceanic Equivalent Sectors	Other On-Site Direct Operating Costs 1979 US\$ (000)
New York ACC	5.0	125
San Juan ACC	1.3	32
Miami ACC	0.67	17
Total	6.97	174

L.3.3 Indirect Operating Costs

Based on informal discussions with FAA, the procurement and installation cost for an oceanic sector (which excludes radar and A/G communications services) is assumed to be US\$ 100,000 (1979 dollars) Assuming a 10 percent discount rate and a 15-year life, each sector's annual depreciation and interest cost is US\$ 13,000. Allowing an additional US\$ 2,000 for miscellaneous indirect costs (insurance premiums, etc.), the indirect operating costs for each ATS unit are:

ATS Unit	Number of NAT Oceanic Equivalent Sectors	On-Site Indirect Operating Cost 1979 US\$ (000)
New York ACC	5	75
San Juan ACC	1.3	20
Miami ACC	0.67	10
Total	6.97	105

L.4 Reykjavik ACC Annual Costs

The 1976 joint financing estimates for the annual operating and maintenance costs for the Reykjavik ACC, as reported by the DCA, Iceland (ref. 18) and submitted to ICAO, are as follows:

Expenditure Item	1976 US\$ (000)
(1) Salaries	502.5
(2) Working expendables	5.6
(3) General operating expenses	36.2
(4) Maintenance expenses	26.7
(5) Indirect expenses	58.1
Total	629.1

The DCA allocates 76.5 percent of the Reykjavik ACC staff to international operations and the remainder to domestic operations (ref. 18). The 76.5 percent factor is assumed to apply to the allocation of the above-listed annual costs to oceanic ATS as shown below:

Expenditure	1976	1979
	US\$ (000)	US\$ (000)
Staff Cost	384.4	511.6
Other Direct Operating Cost	52.4	69.8
Indirect Operating Cost	44.5	59.2
Total	481.3	640.6

Note: Assumed inflation = 10 percent annually = 1.331
inflation factor for 1976 to 1979.

The staff cost category corresponds to item (1) listed above; the other direct operating cost category corresponds to items (2), (3) and (4) listed above, and the indirect operating cost category corresponds to item (5) listed above. The expenditures are converted into 1979 U.S. dollars using the annual inflation rate noted above.

L.5 Santa Maria ACC Annual Costs

Data describing the annual operating and maintenance cost of the Santa Maria ACC are not available. Taking into account the general similarity in scope of operation between the Santa Maria and Reykjavik ACCs and lacking further cost information, the Santa Maria ACC annual costs are assumed to be 80% of those of the Reykjavik ACC because the Santa Maria ACC handles roughly 20 percent less traffic than the Reykjavik ACC.

REFERENCES

1. International Civil Aviation Organization, "International Standards and Recommended Practices, Air Traffic Services," Annex 11 to the Convention on International Civil Aviation, Seventh Edition (April 1978).
2. International Civil Aviation Organization, "International Standards, Rules of the Air," Annex 2 to the Convention on International Civil Aviation, Sixth Edition (September 1970 with amendments through June 1977).
3. International Civil Aviation Organization, "Procedures for Air Navigation Services, Rules of the Air and Air Traffic Services," Doc. 4444-RAC/501/11, Eleventh Edition (1978).
4. International Civil Aviation Organization, "Regional Supplementary Procedures," Doc. 7030/2, Second Edition (1971 with amendments through August 1978).
5. International Civil Aviation Organization, "Air Navigation Plan--North Atlantic, North American and Pacific Regions" (ANP-NAT/NAM/PAC), Doc. 8775/10, Tenth Edition (September 1977).
6. International Civil Aviation Organization, "Air Navigation Plan--Caribbean and South American Regions" (ANP-CAR/SAM), Doc. 8733/10, Tenth Edition (June 1977).
7. International Civil Aviation Organization, "Air Navigation Plan--Africa-Indian Ocean Region" (ANP-AFI), Doc. 7474/21, Twenty-First Edition (December 1977).
8. International Civil Aviation Organization, "Air Navigation Plan--European Region" (ANP-EUR), Doc. 7754/21, Twenty-First Edition (February 1977).
9. International Civil Aviation Organization, "Air Navigation Plan--Middle East and South East Asia Regions" (ANP-MID/SEA), Doc. 8700/12 Twelfth Edition (August 1978).
10. Transport Canada, "Air Traffic Control on the North Atlantic, The Gander Oceanic Operation," Draft Report (June 1979).
11. Directorate of Civil Aviation, Denmark, "A Brief Description and Summary of Problems in Sondrestrom FIR," Paper, Final Version, Copenhagen (April 1979).

12. Civil Aviation Authority, UK, Replies to Data Needs and questions, Letter Listing of Draft Responses, (April 27, 1979).
13. International Civil Aviation Organization, "Methodology for the Derivation of Separation Minima Applied to the Spacing Between Parallel Tracks in ATS Route Structures," Circular 120-AN/89/2, Second Edition (1976).
14. Civil Aviation Authority, UK, "Description of the Shanwick OACC Operation," Draft Paper (1979).
15. D. G. Diment, "The North Atlantic Airspace and the Organized Track System," Draft Paper, Civil Aviation Authority, UK (1978).
16. Civil Aviation Authority, UK, "Survey of North Atlantic System Efficiency--Westbound Traffic Flow," Paper presented to North Atlantic Systems Planning Group, 15th Meeting, Paris (February 1979).
17. Aerosat Coordination Office, Summary description of oral replies by representatives of Director General of Civil Aviation (DGCA) and the Airports and Air Navigation Public Enterprise, Portugal, Letter Listing of Draft Responses (May 28, 1979).
18. Directorate of Civil Aviation, Iceland, "Reykjavik Area Control Centre--Basic Information," Special North Atlantic Panel Working Paper, SNAP-WP/2, Montreal (March 1976).
19. National Weather Service, "Operations of the National Weather Service," PB-286-739, Silver Spring, Maryland (1978).
20. National Weather Service, "Aviation Digital Forecast, Operations Manual," Part D, Chapter 32, Silver Spring, Maryland (September 1978).
21. Civil Aviation Authority, UK, "North Atlantic Air Traffic Services Operating Results for the Year Ended 31 March 1978," extract from the CAA's Annual Report and Accounts for 1977-78.
22. International Monetary Fund, "International Financial Statistics," English, Volume XXXIII, Number 1 (January 1980).
23. Transport Canada, "Description of Present System General Information and Costs," Draft Report No. 1-1/1, Aerospace Systems Section, Telecommunications and Electronics Branch, Transport Canada (May 17, 1979).

— 8
DTIC