

UNCLASSIFIED

SECURITY CLASSIFICATION OF THIS PAGE (When Data Entered)

REPORT DOCUMENTATION PAGE		READ INSTRUCTIONS BEFORE COMPLETING FORM
1. REPORT NUMBER NORDA Technical Note 177	2. GOVT ACCESSION NO.	3. RECIPIENT'S CATALOG NUMBER
4. TITLE (and Subtitle) Possible Applications of GEOSAT-A Radar Altimeter Data to Ice Forecasting in Polar Regions		5. TYPE OF REPORT & PERIOD COVERED Final
		6. PERFORMING ORG. REPORT NUMBER
7. AUTHOR(s) D. Eppler		8. CONTRACT OR GRANT NUMBER(s)
9. PERFORMING ORGANIZATION NAME AND ADDRESS Naval Ocean Research and Development Activity NSTL Station, Mississippi 39529		10. PROGRAM ELEMENT, PROJECT, TASK AREA & WORK UNIT NUMBERS 63207N
11. CONTROLLING OFFICE NAME AND ADDRESS Naval Ocean Research and Development Activity NSTL Station, Mississippi 39529		12. REPORT DATE November 1982
		13. NUMBER OF PAGES 16
14. MONITORING AGENCY NAME & ADDRESS (if different from Controlling Office)		15. SECURITY CLASS. (of this report) UNCLASSIFIED
		15a. DECLASSIFICATION/DOWNGRADING SCHEDULE
16. DISTRIBUTION STATEMENT (of this Report) Distribution Unlimited		
17. DISTRIBUTION STATEMENT (of the abstract entered in Block 20, if different from Report)		
18. SUPPLEMENTARY NOTES		
19. KEY WORDS (Continue on reverse side if necessary and identify by block number) GEOSAT, radar, altimeter, scatterometer, Ku-band, ice, age, roughness, edge, arctic, polar		
20. ABSTRACT (Continue on reverse side if necessary and identify by block number) Backscatter data recorded by satellite-borne radar altimeters that cross polar regions are potential sources of information that can be used to assess the general character of the ice pack, to locate the edge of ice-covered seas, and to delineate polynyas, leads, and areas of open water within the pack. Use of the GEOSAT-A altimeter to acquire these data is severely limited, however, by failure of the instrument to track over ice, the large footprint size characteristic of the satellite sensor (2 km to 7 km), and coverage to only 72°		

DD FORM 1473
1 JAN 73EDITION OF 1 NOV 65 IS OBSOLETE
S/N 0102-LF-014-6601

UNCLASSIFIED

SECURITY CLASSIFICATION OF THIS PAGE (When Data Entered)

UNCLASSIFIED

SECURITY CLASSIFICATION OF THIS PAGE (When Data Entered)

(continued from Block 20)

latitude. Use of the radar altimeter as a Ku-band microwave scatterometer might permit ice surface roughness and age to be predicted from backscatter waveforms. Extraction of this information requires either that the satellite be re-designed to track over ice, or that numerical methods be developed to rectify distorted waveforms acquired over ice. In contrast, ice-water boundaries will be recorded clearly in the backscattered signal by virtue of increases in noise that result from the absence of tracking capability. The precision with which ice edges can be located and the accuracy with which marginal ice zone conditions can be predicted are limited, however, by the altimeter footprint size.

UNCLASSIFIED

SECURITY CLASSIFICATION OF THIS PAGE(When Data Entered)

Naval Ocean Research and
Development Activity
NSTL Station, Mississippi 39529



Possible Applications of GEOSAT-A Radar Altimeter Data to Ice Forecasting in Polar Regions

LIBRARY
RESEARCH REPORTS DIVISION
NAVAL POSTGRADUATE SCHOOL
MONTEREY, CALIFORNIA 93940

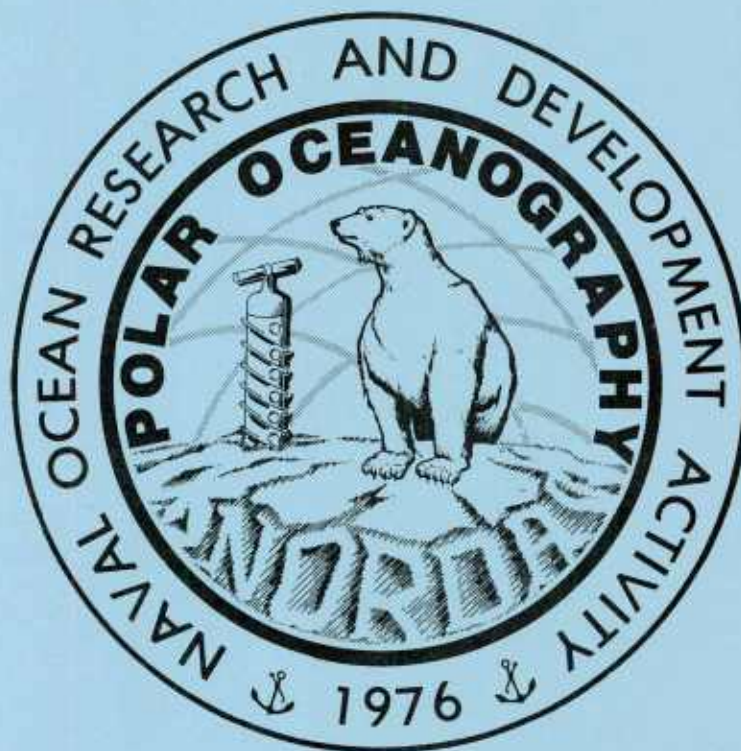

Duane T. Eppler

Ocean Science and Technology Laboratory
Polar Oceanography Division

November 1982

Abstract

Backscatter data recorded by satellite-borne radar altimeters that cross polar regions are potential sources of information that can be used to assess the general character of the ice pack, to locate the edge of ice-covered seas, and to delineate polynyas, leads, and areas of open water within the pack. Use of the GEOSAT-A altimeter to acquire these data is severely limited, however, by failure of the instrument to track over ice, the large footprint size characteristic of the satellite sensor (2 km to 7 km), and coverage to only 72° latitude. Use of the radar altimeter as a Ku-band microwave scatterometer might permit ice surface roughness and age to be predicted from backscatter waveforms. Extraction of this information requires either that the satellite be re-designed to track over ice, or that numerical methods be developed to rectify distorted waveforms acquired over ice. In contrast, ice-water boundaries will be recorded clearly in the backscattered signal by virtue of increases in noise that result from the absence of tracking capability. The precision with which ice edges can be located and the accuracy with which marginal ice zone conditions can be predicted are limited, however, by the altimeter footprint size.

Acknowledgment

This work was performed during FY-82 under NAVAIR program element 63207N, Commander K.L. Van Sickle, program manager. NORDA project coordinator was Dr. Matthew Lybanon of the Remote Sensing Branch.

CONTENTS

Abstract.....	i
Acknowledgment.....	ii
Introduction.....	1
Radar Altimeters: Theory of Operation.....	1
Potential Applications of Altimeter Data to Ice Forecasting.....	3
Ice-Surface Roughness.....	3
Ice Age.....	4
Ice Edges.....	5
Leads, Polynyas, and Open Water.....	6
GEOSAT-A Instrument.....	6
Assessment of GEOSAT-A Capabilities in Polar Regions.....	7
Conclusions.....	8
References Cited.....	10
Figures.....	11

Introduction

Previous workers suggest that backscatter data recorded by satellite-borne radar altimeters that cross polar regions might be used to locate ice edges, to estimate ice roughness and motion, and to assess the general character of the pack (Noble, 1974; Weeks, 1974). These potential applications of satellite altimeter data remain largely undeveloped. Except for algorithms designed to facilitate location of ice edges (Dwyer and Godin, 1980; Martin and Taylor, 1981), altimeter data have been ignored as sources of information regarding Arctic conditions.

Satellite-borne radar altimeters represent low-cost alternatives to many functions performed by complex imaging systems such as synthetic aperture radars (SEASAT), multi-spectral scanners (LANDSAT), and thematic mappers (LANDSAT). Not only are altimeters less expensive to construct, launch, and maintain, but also the cost of receiving, reducing, analysing, and storing acquired data is significantly lower. Furthermore, microwave frequencies used by altimeters penetrate cloud cover and return surface data regardless of weather conditions. Multiple altimeter satellites placed in polar orbit could provide nearly complete arctic coverage and yield near real-time data needed for accurate ice forecasting.

Launch of the GEOSAT-A altimeter in March 1984 will provide a new opportunity to obtain altimeter data over Arctic seas. Coverage of Arctic latitudes, though limited in areal extent, is anticipated to be sufficient to permit ground truth experiments to be conducted. The utility of satellite-borne altimeters in Arctic studies then will be tested. Work reported here reassesses potential applications of altimeter data to Arctic problems in light of GEOSAT-A's projected capabilities.

Radar Altimeters: Theory of Operation

Conventional radar altimeters (GEOS-3, SEASAT-A) utilize compressed pulse radars that operate at Ku-band microwave frequencies (12.9 to 18.0 GHz), typically between 13 and 14 GHz. The instrument transmits Gaussian chirp-pulse signals toward nadir and receives return signals echoed from land and sea surfaces. The pulse front is spherical in form. Its initial contact with the surface illuminates a circular zone at nadir (Fig. 1). The radius of the illuminated zone increases with time and remains circular until the trailing edge of the pulse intersects the earth's surface. Hereafter a torus-shaped zone whose radius increases with time is illuminated. Energy impinging the surface is scattered back to the satellite from points whose normals point toward the satellite. Energy scattered from points near nadir reach the satellite before energy from points increasingly distant from nadir.

Energy received by the satellite is partitioned into a series of temporal gates. Each gate corresponds to a discrete time interval measured relative to T_0 , the arrival time of the leading edge of the return waveform at the satellite. The intensity of backscatter captured during a given interval is stored in its respective gate. Returns from multiple pulses are averaged periodically, commonly every second. Information stored in each gate corresponds to surface conditions within the circle or ring illuminated by the pulse. The location of the illuminated area with respect to nadir is relatively constant from pulse to pulse.

Information regarding roughness of the surface is contained in the shape of the backscatter waveform received by the satellite. Backscatter typically is represented graphically as a plot of returned power as a function of time. The shape of the return waveform is skewed toward late returns (Fig. 2). Backscatter intensity increases rapidly to a peak after arrival of the first return at T_0 . This portion of the curve is called the ramp. Energy returned in the ramp segment of the curve and near the peak represents reflection from points close to nadir. Energy returned at increasingly later times represents reflections from points at increasing distance from nadir.

Waveforms produced by flat, reflective surfaces are characterized by steep ramps, high peaks, and rapid decay of the backscatter signal (Fig. 2). Surfaces that exhibit roughness near nadir scatter a high percentage of the signal away from the satellite. This decreases the slope of the ramp and results in a lower, broader peak. Rough surfaces at distance from nadir scatter a significant percentage of the signal toward the satellite. This creates an abundance of late returns that slow the rate at which the signal decays. As a result, the peak is stretched to become a plateau. Waveforms associated with scattering from rough surfaces thus exhibit shallower ramps, lower peak energy, and markedly slower decay when compared to waveforms returned by purely specular reflection.

Scattering from ice is primarily specular and comes predominantly from points near nadir. Early backscatter sensed by the satellite thus is strong. Intensity of the backscatter signal decreases rapidly with time primarily because the number of points oriented toward the satellite decreases rapidly with distance from nadir. Scatter from sea surfaces is quasi-specular and comes from glitter points located within 15° of satellite nadir (Barrick, 1972). The initial return is weaker than that from ice because fewer points near nadir scatter the signal toward the satellite. The peak is sustained longer, however, because the number of off-nadir points that are oriented toward the satellite is greater. Accordingly, decay of the backscatter return occurs at an appreciably slower rate.

The footprint area from which backscatter is received varies with surface roughness. Reflection from smooth, specular surfaces comes largely, though not exclusively, from

points from within one kilometer of nadir (Townsend, 1980). Rough ice contributes backscatter from ridges at distance from nadir, thereby increasing footprint size. Returns from rough surfaces such as heavy seas come primarily from points within 3.5 kilometers of nadir. The altimeter footprint thus is as small as two kilometers over smooth ice, and seven kilometers or more over heavy seas.

Potential Applications of Altimeter Data to Ice Forecasting

Potential uses for satellite-borne radar altimeters in Arctic regions have been noted by previous workers (Noble, 1974; Weeks, 1974; Dwyer and Godin, 1980; Martin and Taylor, 1981). These applications can be grouped into four categories, each of which has scientific as well as tactical significance:

1. locate zones of extensive surface roughness,
2. predict ice conditions,
3. locate the ice edge and characterize marginal ice zone (MIZ) conditions, and
4. locate leads, polynyas, and areas of open water of significant size within the pack.

1. Ice-Surface Roughness

Altimeter data gathered over ice-covered seas contains information regarding surface roughness of the ice pack. Because smooth ice gives a specular return of the radar pulse, the shape of the returned signal is characterized by a steep ramp and a high peak return which rapidly decays with time (Fig. 2). Ridges roughen the ice surface. Their effect on the return signal is two-fold. First, a higher percentage of energy impinging the surface near nadir is lost due to scattering away from the satellite-sensor. Second, ridges far outside the normal narrow area of specular return reflect energy at angles that will reach the sensor. This results in a greater number of late returns.

The backscatter waveform reflects these differences between smooth and ridged ice. Loss of energy reduces the height of the peak formed by early returns that come from purely specular reflections from flat ice surfaces. The ramp slope might be slightly shallower as well. Late returns from ridges offset from nadir decrease the slope of the return beyond the initial peak. Except where extremely rough ice is encountered, these late returns probably are not numerous enough to create plateaus of the sort characteristic of returns from ocean surfaces. Nonetheless, sufficient differences might exist between returns from ridged and smooth ice to estimate ridge density from backscatter waveforms (Fig. 3). Occurrence of swarms of ridges at equal distance from nadir could produce secondary peaks on the return waveform, especially if their orientation is optimum. However, ridged

areas that produce secondary peaks would have to be arrayed in ring-like patterns centered on nadir insofar as the illuminated area at distance from nadir is torus-shaped. Occurrence of ridges in concentric arrays is not common.

2. Ice Age

Response of ice to Ku-band microwave radiation varies with ice properties. Physical ice characteristics such as thickness, temperature, salinity, density, and snow cover affect emissivity and reflectance. The relative age of ice (first-year, multi-year) determines the state of many of these variables. Multi-year ice, for example, is significantly less saline and considerably denser than first-year ice. The shape of the backscatter waveform reflects these changes as a consequence of the fact that different amounts of energy are reflected by ice of different character.

Measurement of the brightness temperature of first-year and multi-year ice at 13.4 GHz indicates that the emissivity of first-year ice is greater than that of multi-year ice at this frequency (Campbell, et al., 1978). The relationship between emissivity (E) and reflectance (R) is given by:

$$R = (1-E) \qquad (1)$$

which suggests that first-year ice reflects less radiation than multi-year ice. Backscatter from first-year ice, then, should be lower than that from multi-year ice under the same conditions. This result is confirmed at 13.3 GHz by Hawkins, et al. (1981) for both summer and winter conditions.

Analysis of the waveform could provide information regarding regional-scale changes in the character of the ice pack. Energy returned from the surface is integrated across the circle or annulus subtended by the sampling gate. If the annulus encompasses predominantly first-year ice, then the return will be dominantly first-year in intensity (Fig. 4). A dominantly multi-year field will provide primarily a multi-year return. Mixed fields should return backscatter responses located within a continuum between endmember backscatter classes that represent first- and multi-year fields. Analysis of early returns that are reflected from regions located near nadir probably will provide the clearest indication of ice characteristics. Here the footprint is circular and includes ice that is most likely to be homogeneous. Footprints of backscatter received at later times are torus shaped and are far more likely to encompass ice that displays wide variation in physical characteristics. Comparison between peak returns from successive waveforms will provide an indication of variation in the physical character of the ice. Analysis of altimeter data in this light could provide information regarding regional-scale boundaries between large areas of first- and multi-year ice.

3. Ice Edges

Ku-band frequencies in which satellite-borne radar altimeters operate (12.9 to 18.0 GHz) are particularly well suited to discriminating water from non-water surfaces (Miller, 1979). Backscatter waveforms for non-water (land and ice) surfaces are characterized by steep ramp, high energy peak, and relatively rapid backscatter decay (Fig. 2). Returns from fluid surfaces display shallow ramp slopes, lower peak return, and considerably longer decay. These differences facilitate detection of the ice edge. Algorithms designed to sense the location of ice/water boundaries in radar altimeter data utilize automatic gain control (AGC) values coupled with data provided by other gates (Dwyer and Godin, 1980; Martin and Taylor, 1981).

Martin and Taylor (1981) suggest that increases in both significant wave-height error and root-mean-square (RMS) noise associated with computation of sea-surface height (Fedor and Barrick, 1978; Priester and Miller, 1979; Lipa and Barrick, 1981) are indicative of crossings to ice covered seas when evaluated with AGC data. Backscatter from ice is significantly more noisy than backscatter from water with respect to RMS errors. This increased noise probably reflects the change from a surface characterized by complex but periodic waveforms (ocean) to one that is predominantly planer with abrupt ridges and shallow depressions present at irregular intervals (ice).

Curiously, this effect, at least as observed in GEOS-3 and SEASAT-A data, does not result directly from readings of surface conditions. Rather, it is an artifact of data processing hardware onboard the satellite. Satellite hardware is designed to control the gain of backscatter received from ocean surfaces rather than from ice. Algorithms employed to perform this function use AGC data to normalize receiver gain. Fundamental differences between returns from ice and fluid water cause saturation of the signal when backscatter is received from ice. Algorithms used subsequently to analyze the AGC-normalized signal treat the saturated signal as noise. Substantial increases in RMS error for data acquired over ice result.

Dwyer and Godin (1980) augment AGC data with data from the average attitude specular gate (AASG). Energy received by this gate consists of late returns backscattered from surfaces at distance from nadir (Fig. 2). Since backscatter from ice is predominantly specular and the ice surface planer when compared with sea surfaces, the intensity of late returns is lower over ice than over water. AASG readings drop markedly as the instrument moves over ice as a consequence. Conversely, AGC readings, which measure one-second averages of backscatter return at or close to nadir, increase radically over ice in response to specular reflection from the smooth ice surface.

Compact marginal ice zones are detected easily in altimeter data using these techniques. Analysis of AGC data in combination with either AASG, height errors, or RMS noise associated with sea-surface heights generally permits an ice edge to be identified. Dispersed MIZ's create a nebulous ice edge that is more difficult to identify. Under strong off-ice winds, the MIZ consists of a dispersed band of floating ice up to 100 km deep; the outer 50 km commonly consists predominantly of isolated floes separated by brash, grease ice, or open water. Work that examines the effect of dispersed MIZ on backscatter waveforms is insufficient to permit ice edges to be located precisely under these conditions.

4. Leads, Polynyas, and Open Water

Sizable bodies of open water within the pack in the form of leads and polynyas should be evident in altimeter data. Large bodies of open water can be recognized by changes in the character of the backscatter waveform from specular (ice) to quasi-specular (open water) and back to specular (ice). Such changes only will be distinct if the areal extent of open water within the pack is greater than the altimeter footprint.

Openings that are smaller than the footprint size might be detected if successive backscatter waveforms are searched for systematic changes that indicate the presence of quasi-specular reflectors within the footprint. Decreases in the height of the early backscatter peak with concomitant increases in the intensity of late returns over that expected for heavily ridged ice could indicate the presence of open water. Lower size limits of openings that can be detected depend on the size of the the backscatter footprint. Two-kilometer footprints are typical of specular reflectors; seven-kilometer footprints are typical of rough, quasi-specular reflectors. Floating ice occurring within zones of open water will determine, in part, the size of openings that can be detected.

GEOSAT-A Instrument

GEOSAT-A is scheduled for launch in March, 1984. The satellite will be placed in a circular orbit with a period of 6045 seconds (1 hr., 40.8 min.) at an altitude of 800 km. The orbit will be inclined 108° to allow coverage between $+72^\circ$ latitude. Equator crossings 14 to 15 km apart will be achieved six months after launch; coverage in polar regions will be nearly continuous. Operational life of the satellite is anticipated to be three years.

The GEOSAT-A altimeter will employ a nadir-looking pulse-compression radar operating at 13.5 GHz (Ku-band microwave). Temporal pulse width of the instrument is 102.4 ns, which consists of an active 3.2 ns pulse and an interpulse

period of 99.2 ns. The pulse waveform conforms to a Gaussian distribution. The pulse is transmitted via a one meter parabolic antenna with a beamwidth of 2.1° and a minimum gain of 37.6 dB. The GEOSAT-A instrument essentially is identical to the SEASAT-A altimeter with the exception of an increase in beamwidth from SEASAT-A's 1.6° , and a concomitant decrease in gain from SEASAT's 40 dB. Operation of the GEOSAT instrument will not be degraded with respect to SEASAT's performance as a result of these differences. The instrument is designed to measure significant wave height ($H_{1/3}$) to $\pm 10\%$, or to 0.5 meters. Wind speed will be measured to a precision of 1.8 m/s over the range of 1 to 18 m/s. Altitude will be measured to 3.5 cm precision for a significant wave height of 2 meters.

One averaged data sample will be recorded in each of 63 gates every 0.1 second (0.74 km) along the orbit track. Data will be available approximately two weeks after acquisition. The footprint of each pulse is projected to be approximately 2 km for calm seas (and smooth terrain) and approximately 7 km for rough seas. The instrument is not designed to track over completely ice covered areas, although development of new analysis techniques could permit information of some utility to ice forecasting applications to be extracted from the waveform.

Assessment of GEOSAT-A Capabilities in Polar Regions

Use of the GEOSAT-A instrument to estimate ice-surface roughness, map ice age distributions, and locate leads and polynyas within the pack is severely limited by failure of the instrument to track over ice. This deficiency is related to the fact that feedback loops designed to normalize signal gain are calibrated with respect to backscatter received from ocean surfaces rather than ice. Unless methods can be developed to reconstruct the original signal from distorted waveforms, it is unlikely that useful information can be derived regarding surface conditions within the pack.

Failure of the sensor to track over ice will have a less drastic effect on GEOSAT-A's ability to locate ice edges and characterize the marginal ice zone (MIZ). Crossings from water to ice (on-ice crossings) will be recorded clearly by the increase in RMS noise that results from the absence of tracking capability. However, the precision with which ice edges can be located and the accuracy with which MIZ conditions can be predicted are limited by the footprint size that is characteristic of the instrument. The absolute minimum size of features that can be detected is limited to 2 km if raw, unaveraged data are used. In practice, the instrument resolution probably will be considerably greater than 2 km, especially with regard to locating ice edges. If data are averaged over one second intervals, then resolution is reduced further parallel to the ground track due to

satellite motion. Orientation of the trend of the MIZ with respect to the satellite ground track will determine the degree to which data are degraded by averaging.

Ice edges will be marked with lower precision on crossings from ice to water (off-ice crossings). Several seconds are required to damp oscillations in the feedback loop after ocean backscatter is acquired. Thus, normal tracking might not resume until the satellite is well beyond the ice edge. Because dispersed ice edges take longer to traverse than compact ice edges, dispersed ice edges will be located more precisely than compact ice edges on off-ice crossings. This results from the fact that the altimeter sensor has more time to recover before the entire MIZ is crossed.

A launch before summer 1984 could provide an opportunity to assess the accuracy and precision of the sensor and calibrate its response to (MIZ) conditions in conjunction with the Marginal Ice Zone Experiment (MIZEX). MIZ conditions in the Fram Strait region will be monitored continuously for six weeks during July and August 1984 by ground personnel stationed within and adjacent to the MIZ. Data that document daily changes of the MIZ and ice edge locations will be gathered in situ by MIZEX personnel. Comparison between GEOSAT-A altimeter data and MIZ conditions will permit the response of the instrument to changes in ice concentration and differences between on- and off-ice margin crossings to be defined.

The fact that the proposed orbit provides coverage to only 72° limits the areal extent of ice covered areas over which the satellite will pass. This could interfere with use of the satellite during MIZEX if climatic conditions restrict development of the ice cover during winter 1983-1984. Although overall assessment of the applicability of GEOSAT data to polar problems will not be hindered significantly by limited coverage, the utility of GEOSAT-A with respect to tactical and operational uses will be restricted. On the other hand, the lower orbital limit increases coverage of the marginal ice zone due to the fact that successive ground-tracks are closer together than they would be at higher orbital inclinations.

Conclusions

1. The primary application of GEOSAT-A altimeter data is in locating ice/ocean boundaries and characterizing marginal ice zone conditions. The altimeter will play a secondary role as an aid to locating areas of open water within the ice pack.

2. The utility of GEOSAT-A to Arctic remote sensing and ice forecasting problems is limited by three factors: a) large footprint size (2 km to 7 km), b) coverage to only 72° latitude, and c) failure of the instrument to track over ice-covered areas.

3. Use of the radar altimeter as a Ku-band microwave scatterometer might permit ice surface roughness and age to be predicted on a regional scale from the backscatter waveform. However, extraction of this information requires that the satellite be designed to track over ice-covered regions.

References Cited

- BARRICK, D.E., 1972, Remote sensing of sea state by radar, in Derr, V.E., ed., Remote sensing of the troposphere: p.12-1 - 12-46.
- CAMPBELL, W.J., Wayenberg, J., Ramseyer, J.B., Ramseier, R.O., Vant, M.R., Weaver, R., Redmond, A., Arsenault, L., Gloerson, P., Zwally, H.J., Wilheit, T.T., Chang, T.C., Hall, D., Gray, L., Meeks, D.C., Bryan, M.L., Barath, F.T., Elachi, C., Leberl, F., and Farr, T., 1978, Microwave remote sensing of sea ice in the AIDJEX main experiment: Boundary-Layer Meteorology, v.13, p.309-337.
- DWYER, R.E., and GODIN, R.H., 1980, Determining sea-ice boundaries and ice roughness using GEOS-3 altimeter data: NASA Contractor Report 156862, 45p.
- HAWKINS, R.K., Gray, C.E., Livingstone, C.E., and Arsenault, L.D., 1981, Seasonal effects of the microwave signatures of Beaufort sea ice: International Symposium on Remote Sensing of Environment, Ann Arbor, p.239-257.
- LIPA, B.J., and BARRICK, D.E., 1981, Ocean surface height-slope probability density function from SEASAT altimeter echo: J. Geophys. Res., v.86, n.C11, p.10921-10930.
- MARTIN, C.F., and TAYLOR, R.L., 1981, Boundary detection criteria for satellite altimeters: NASA Contractor Report 156880, 57p.
- MILLER, L.S., 1979, Topographic and backscatter characteristics of GEOS-3 overland data: J. Geophys. Res., v.84, n.B8, p.4045-4054.
- NOBLE, V., 1974, Exploitation of SEASAT-A oceanographic measurements on Navy RD applications, in SEASAT-A scientific contributions: NASA-TM-X-72944, p.85-88.
- PRIESTER, R.W., and MILLER, L.S., 1979, Estimation of significant wave height density function using satellite altimeter data: J. Geophys. Res., v.84, n.B8, p.4021-4026.
- TOWNSEND, W.F., 1980, An initial assessment of the performance achieved by the SEASAT-1 radar altimeter: IEEE J. Ocean. Eng., v.OE-5, n.2, p.80-92.
- WEEKS, W.F., 1974, SEASAT and floating ice, in, SEASAT-A Scientific Contributions: NASA-TM-X-72944, p.134-135.

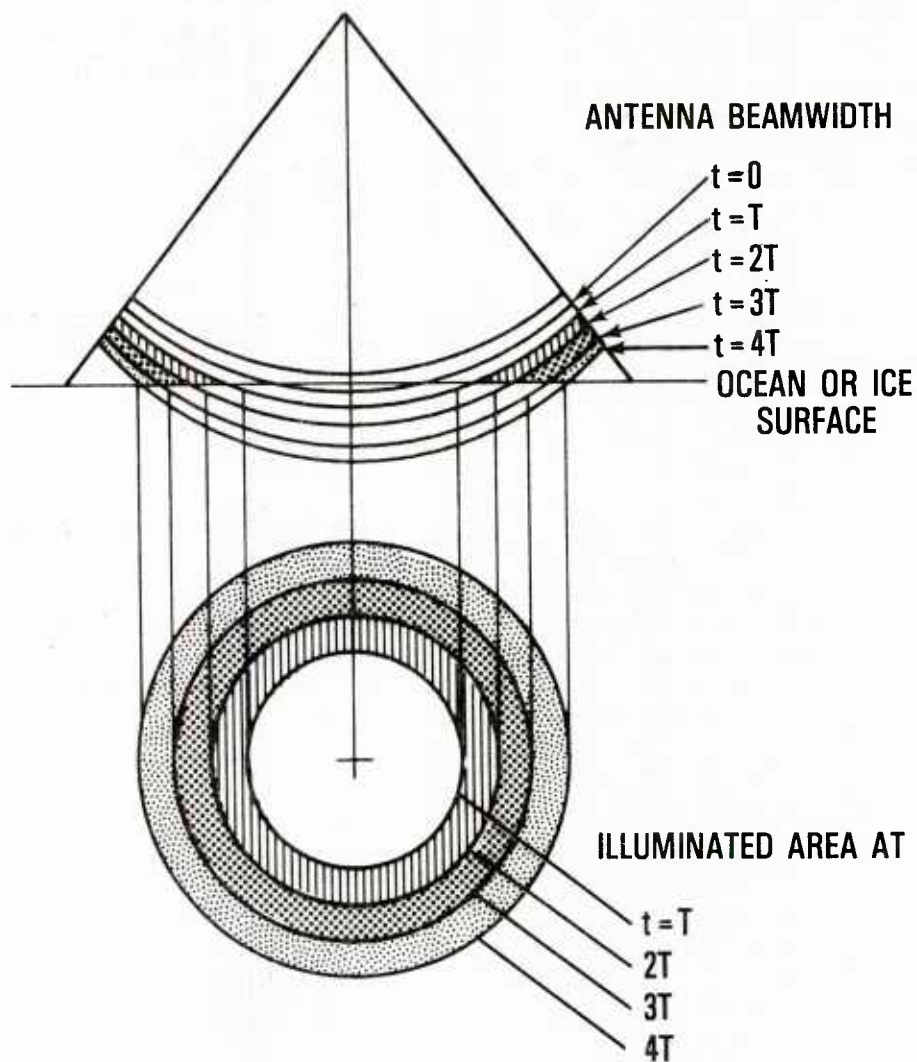

Figure 1. Illumination of the earth's surface by an altimeter pulse of width T . From Time 0 to Time T , the illuminated footprint is circular in shape. At Time T the trailing edge of the pulse intersects the surface. Thereafter the illuminated area is torus-shaped.

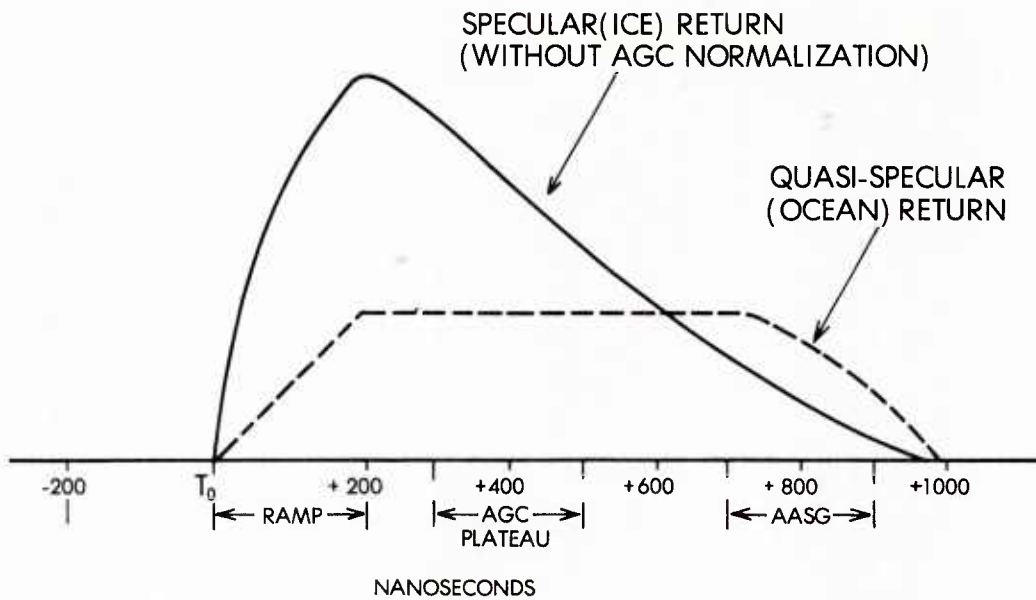

Figure 2. Backscatter waveforms from specular reflectors (ice) and quasi-specular reflectors (water). Waveforms that correspond to specular reflectors are characterized by steep ramps, high peak returns, and rapid signal decay because a high percentage of the transmitted energy is returned to the satellite from points at or near nadir. Quasi-specular reflectors scatter a larger percentage of the signal away from the satellite and so are characterized by shallower ramps and lower peak returns.

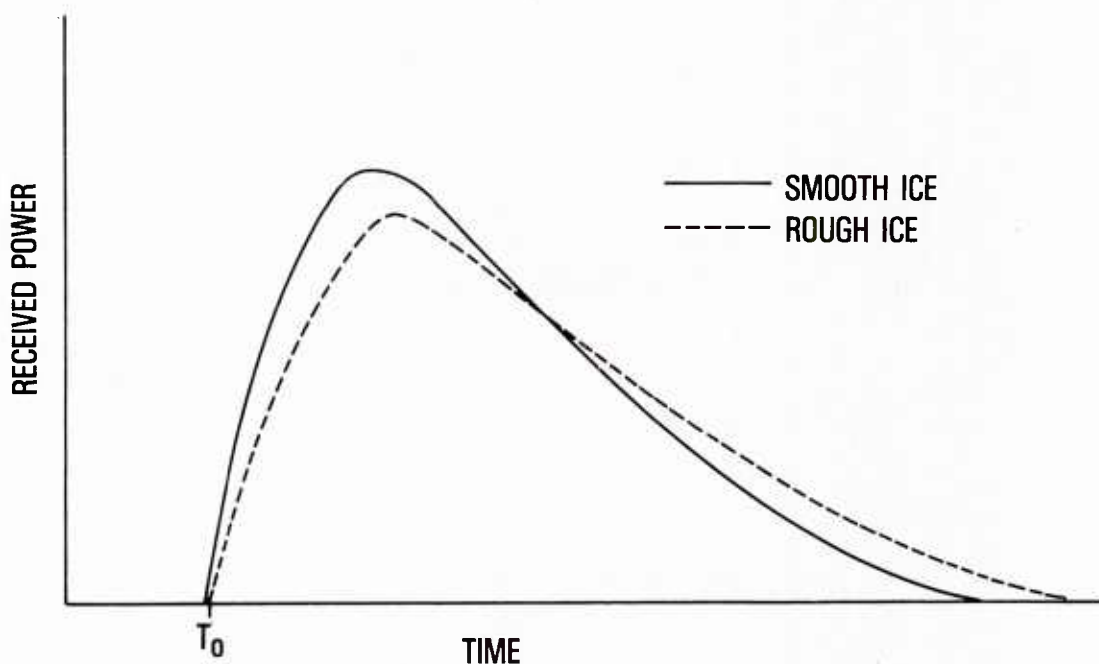

Figure 3. Hypothetical backscatter waveforms from smooth and ridged ice. Backscatter from ridged ice consists of a higher number of late returns than does backscatter from smooth ice. Waveforms returned from ridged ice thus are expected to be skewed more strongly towards later return times.

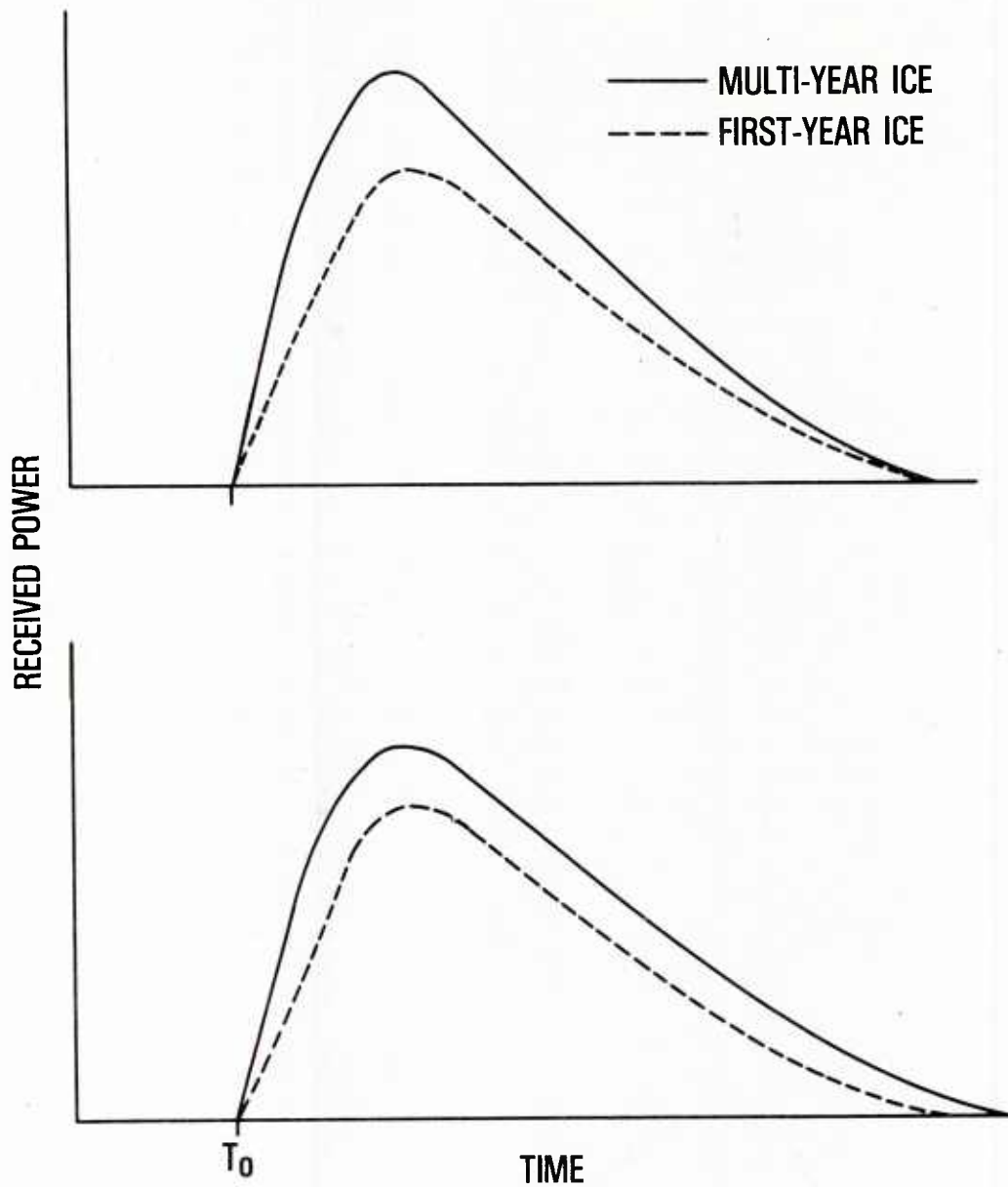

Figure 4. Hypothetical backscatter wave forms from first- and multi-year ice. Multi-year ice reflects a higher percentage of Ku-band radiation than does first-year ice (Hawkins, et al., 1981). As a consequence, the peak return for multi-year ice is expected to be higher than that for first-year ice (upper graph). Multi-year ice typically is rougher than first-year ice. Less energy will be reflected from points near nadir and more energy will be reflected from points off nadir as a result. If this factor is taken into account, the peak return from multi-year ice is expected to be diminished slightly, and the waveform skewed toward later return times (lower graph).