

AD-A124 273

LEP-L  
TECHNICAL  
LIBRARY

AD 4124 273

AD-E400 955

TECHNICAL REPORT ARLCD-TR-82029

**MINIMUM NONPROPAGATION DISTANCES FOR VARIOUS LAP FACILITY  
CONFIGURATIONS OF THE 30-MM XM789 HEDP PROJECTILES**

**WILLIAM M. STIRRAT  
RICHARD M. RINDNER**

**JANUARY 1983**



**US ARMY ARMAMENT RESEARCH AND DEVELOPMENT COMMAND  
LARGE CALIBER  
WEAPON SYSTEMS LABORATORY  
DOVER, NEW JERSEY**

**APPROVED FOR PUBLIC RELEASE; DISTRIBUTION UNLIMITED.**

**The views, opinions, and/or findings contained in this report are those of the author(s) and should not be construed as an official Department of the Army position, policy, or decision, unless so designated by other documentation.**

**Destroy this report when no longer needed. Do not return to the originator.**

REPORT DOCUMENTATION PAGE		READ INSTRUCTIONS BEFORE COMPLETING FORM
1. REPORT NUMBER Technical Report ARLCD-TR-82029	2. GOVT ACCESSION NO.	3. RECIPIENT'S CATALOG NUMBER
4. TITLE (and Subtitle) MINIMUM NONPROPAGATION DISTANCES FOR VARIOUS LAP FACILITY CONFIGURATIONS OF THE 30-mm XM789 HEDP PROJECTILES		5. TYPE OF REPORT & PERIOD COVERED Final Oct 80 - Sep 82
		6. PERFORMING ORG. REPORT NUMBER
7. AUTHOR(s) William M. Stirrat Richard M. Rindner		8. CONTRACT OR GRANT NUMBER(s)
9. PERFORMING ORGANIZATION NAME AND ADDRESS ARRADCOM, LCL Energetic Systems Process Div (DRDAR-LCM-SP) Dover, NJ 07801		10. PROGRAM ELEMENT, PROJECT, TASK AREA & WORK UNIT NUMBERS MMT-5814288
11. CONTROLLING OFFICE NAME AND ADDRESS ARRADCOM, TSD STINFO Div (DRDAR-TSS) Dover, NJ 07801		12. REPORT DATE January 1983
14. MONITORING AGENCY NAME & ADDRESS (if different from Controlling Office)		13. NUMBER OF PAGES 66
		15. SECURITY CLASS. (of this report) UNCLASSIFIED
		15a. DECLASSIFICATION/DOWNGRADING SCHEDULE
16. DISTRIBUTION STATEMENT (of this Report)  Approved for public release; distribution unlimited.		
17. DISTRIBUTION STATEMENT (of the abstract entered in Block 20, if different from Report)		
18. SUPPLEMENTARY NOTES This project was accomplished as part of the U.S. Army's Manufacturing Methods and Technology Program. The primary objective of this program is to develop, on a timely basis, manufacturing processes, techniques and equipment for use in the (cont)		
19. KEY WORDS (Continue on reverse side if necessary and identify by block number) Minimum nonpropagation distance 30-mm XM789 HEDP projectile PBXM-5 XM714 PD fuze MMT-Ammunition		
20. ABSTRACT (Continue on reverse side if necessary and identify by block number) As part of an Army wide expansion and modernization program, the safe separation distances for various production facility configurations of 30-mm XM789 HEDP projectiles were studied, tested, and statistically determined in a series of tests. The test results were used to establish safety criteria for new manufacturing Load-Assemble-Pack (LAP) facilities and also existing facilities undergoing renovation. The program to determine the necessary minimum nonpropagation distance was drafted by ARRADCOM and was subsequently conducted in a series of six test (cont)		

## 18. SUPPLEMENTARY NOTES (cont)

production of Army materiel. Test coordination and basic data reduction were accomplished by the ARRADCOM Resident Operations Office, National Space Technology Laboratories, NSTL Station, Mississippi. Both exploratory and confirmatory test phases were conducted by the Hazard Range Support Unit of Computer Science Corporation of NSTL.

## 20. ABSTRACT (cont)

phases. Within each test phase, exploratory and confirmatory tests were conducted resulting in the following safe separation distances, statistically confirmed at the 95% confidence level: (1) bare PBXM-5 pellets, stacked two each, 25.4 millimeters (1.0 inch) resulted in a 6.84% probability of propagation, (2) shell body with loose pellets inserted, 25.4 millimeters (1.0 inch) resulted in a 6.60% propagation probability, (3) loaded body assembly, 25.4 millimeters (1.0 inch) resulted in a 7.10% propagation probability, (4) loaded body assembly (heated), 76.2 millimeters (3.0 inches) resulted in a 7.10% propagation probability, (5) fuzed projectile, 76.2 millimeters (3.0 inches) resulted in a 5.97% propagation probability, and (6) fuzed projectile (heated) propagations were recorded up to and including distances of 381.0 millimeters (15.0 inches).

## CONTENTS

	Page
Introduction	1
Background	1
Objective	1
Criteria for Tests	2
Test Configuration	3
General	3
Test Specimens	3
Test Arrangements	4
Methods of Initiation	5
Test Results	6
General	6
Results of Individual Test Series	6
Hardware Configuration 1 - Bare PBXN-5 Pellets	6
Hardware Configuration 2 - Shell Body with Loose Pellets	6
Hardware Configuration 3 - Loaded Body Assembly	7
Hardware Configuration 4 - Heated Loaded Body Assembly	7
Hardware Configuration 5 - Fuzed Projectile	7
Hardware Configuration 6 - Heated Fuzed Projectile	8
Summary of Test Results	8
Analysis of Test Results	8
Conclusions and Recommendations	10
Appendix - Statistical Evaluation of Explosion Propagation	53
Distribution List	59

## TABLES

		Page
1	Test data summary - Bare PBXN-5 pellets - 2 per unit (Hardware Configuration #1)	11
2	Test data summary - Shell body with 2 loose PBXN-5 pellets (Hardware Configuration #2)	14
3	Test data summary - Loaded body assembly (Hardware Configuration #3)	17
4	Test data summary - Loaded body assembly - Heated (Hardware Configuration #4)	19
5	Test data summary - 30MM XM789 HEDP Projectile with XM714E6 PD Fuze (Hardware Configuration #5)	23
6	Test data summary - Fuzed Projectile - Horizontally aligned and heated (Hardware Configuration #6)	28
7	Program results summary - 30MM XM789 HEDP Projectile	29

## FIGURES

1	30MM XM789 HEDP Projectile hardware Configuration #1, (bare PBXN-5 pellets)	30
2	30MM XM789 HEDP Projectile hardware Configuration #2, (shell body with loose pellets)	31
3	30MM XM789 HEDP Projectile hardware Configuration #3, (loaded projectile body)	32
4	30MM XM789 HEDP Projectile hardware Configuration #5, (fuzed projectile)	33
5	30MM XM789 HEDP Projectile; test array for configuration #1	34
6	30MM XM789 HEDP Projectile; test array for configuration #2	35
7	30MM XM789 HEDP Projectile; test array for configuration #3	36
8	30MM XM789 HEDP Projectile; test array for configuration #5	37
9	Loaded body assembly at elevated temperature; pre-test configuration	38
10	Loaded body assembly at elevated temperature; pre-test oven configuration	39
11	Complete projectile at elevated cone temperature of 205°F positioned and aligned horizontally; pre-test configuration	40
12	30MM XM789 Projectile with J2 electric blasting cap	41
13	30MM XM789 Projectile with M6 electric blasting cap	42

14	Bare PBXN-5 pellets, 2 each; post-test results, non-propagation	43
15	Bare PBXN-5 pellets, 2 each; post-test results, propagation of all acceptors	44
16	Shell bodies with loose pellets; post-test results, low order propagation to inner acceptors	45
17	Loaded body assembly; post-test results, low order propagation to inner acceptors	46
18	Loaded body assembly at elevated cone temperature of 205°F; post-test results	47
19	Fuzed projectile; post-test results, complete non-propagation	48
20	Fuzed projectile; post-test results, propagation of inner acceptors	49
21	Complete projectile at elevated cone temperature of 205°F positioned and aligned horizontally; post-test destruction	50
22	Complete projectile at elevated cone temperature of 205°F positioned and aligned horizontally; post-test penetration	51

## INTRODUCTION

### Background

At the present time, an Army-wide modernization and expansion program is underway to upgrade existing and develop new explosive manufacturing and Load-Assemble-Pack (LAP) facilities. This effort will enable the U.S. Army to achieve increased production cost effectiveness with improved safety, as well as provide manufacturing facilities for new weaponry within existing facilities. As an integral segment of the overall program, the Energetic Systems Process Division, Large Caliber Weapon Systems Laboratory, ARRADCOM, Dover, New Jersey, is engaged in the continuous development of munitions safety criteria as an activity entitled "Safety Engineering in Support of Ammunition Plants". This activity includes safe separation (non-propagation) distance studies of ammunition end-items as well as in-process explosive materials. The criteria developed from these study programs will be utilized as part of the basis for the design of all explosive installations due for modernization, and will be available for reference purposes to privately-owned and operated (POPO) plants engaged in explosive ordnance manufacturing operations.

The test activities described within this report were undertaken at the request of the Materials and Manufacturing Technical Division of the Fire Control and Small Caliber Weapon Systems Laboratory (ARRADCOM), Dover, New Jersey, and will provide munitions safety criteria for the establishment of a new LAP facility for the manufacture of 30MM XM789 HEDP Projectiles at Twin Cities Army Ammunition Plant, New Brighton, Minnesota. In order to establish the necessary safety criteria, the line layout drawings were reviewed, and it was mutually determined that six component configurations should be examined to determine their non-propagating distances.

The six configurations are:

1. Two each 13.5-gram PBXN-5 Type 2 pellets, stacked vertically one on the other.
2. The projectile body with two pellets.
3. The fully loaded body assembly.
4. The fully loaded body assembly heated.
5. The fuzed projectile.
6. The fuzed projectile heated.

### Objective

The objective of this program segment was to determine experimentally the minimum safe (non-propagating) separation distances for all six LAP facility configurations to be utilized at the Twin Cities Army Ammunition Plant. Each proposed facility configuration was subjected to an individual test sequence consisting of two phases. The first phase involved a series of exploratory test

detonations for the purpose of establishing the necessary clear spacing between adjacent components while on transfer carriages and/or conveyor systems. The second phase consisted of sufficient confirmatory tests at the previously established distance to create a statistical confidence level.

#### Criteria for Tests

The testing of the six component configurations of the 30MM XM789 HEDP Projectile was conducted in such a manner as to accurately simulate the proposed LAP facility conditions. The only acceptable criteria for determining the safe clear separation distances for the various component configurations was the non-propagation of the donor component (initiated charge) detonation to the acceptor components. Note that the clear distances are measured edge to edge on the adjacent components.

## TEST CONFIGURATION

### General

The safe separation distance test program for all six LAP facility component configurations of the 30-MM XM789 HEDP Projectile was performed under the auspices of the ARRADCOM Resident Operations Office in conjunction with the Hazards Range Support Unit of Computer Science Corporation, both located at the National Space Technology Laboratories, Mississippi. Two phases of testing, exploratory and confirmatory, were accomplished for each of the six LAP configurations in order to firmly establish the minimum non-propagating distances between the various components. This program may be considered as consisting of six separate test sequences or series, each corresponding to one of the particular LAP hardware configurations.

### Test Specimens

For the purposes of this test program segment, there were six different test specimens, each conforming to a particular LAP hardware configuration on the projectile loading lines.

The first hardware configuration consisted of two 13.5-gram hollow core PBXN-5, type 2 (MIL-E-8111) pellets, one stacked vertically on top of the other as shown in figure 1.

The second hardware configuration consisted of vertically positioned 30mm shell bodies (P/N 28114055) each containing two loosely fitted 13.5-gram PBXN-5 pellets as shown in figure 2.

The third hardware configuration consisted of the 30mm HEDP loaded body assembly (P/N 28114060) which included, in addition to the shell body and 27.0 grams of reconsolidated PBXN-5 composition, a flute-shaped charge liner, a retaining ring and an 0.08-gram PBXN-5 booster charge. The loaded body assembly, as shown in figure 3, was positioned vertically on a simulated conveyor.

The fourth hardware configuration consisted of the same loaded body assembly as in the third configuration above; however, it was heated to an internal temperature of 96°C (205°F) prior to initiation. This hardware configuration was also positioned vertically on a simulated conveyor.

The fifth hardware configuration consisted of a complete 30MM XM789 HEDP Projectile with an XM714E6 PD Fuze as shown in figure 4. Again, the projectiles were positioned vertically on a simulated conveyor.

The sixth hardware configuration also consisted of the complete 30MM XM789 HEDP Projectile with XM714E6 PD Fuze; however, in this case, the units were positioned horizontally nose to tail and heated to an internal temperature of 96°C (205°F).

## Test Arrangements

The test arrangements for the first hardware configuration, bare PBXN-5 pellets, consisted of five test units (two pellets per test unit) aligned in a straight line on a 1.27-centimeter (0.5-inch) thick steel witness plate as shown in figure 5. This test array was then positioned on a pine board 2.54 centimeters (1.0 inch) thick by 15.24 centimeters (6.0 inches) wide by 2.44 meters (8.0 feet) in length and supported by low density concrete blocks at both ends, at a distance of 45.7 centimeters (18.0 inches) above the existing terrain. The center pallet unit was initiated as the donor and the two acceptors on each side were examined for propagation of the donor detonation. A total of seven exploratory tests and 25 confirmatory tests were conducted, utilizing the single donor, dual acceptor methodology. This was the only hardware configuration where the steel witness plates were utilized throughout the whole test series. Since the pellets from non-propagated acceptors were usually pulverized by the donor blast, the only possible post-test analysis was the witness plate markings.

The test arrangements for the second, third and fifth hardware configurations - shell body with loose pellets, loaded body assemblies and fuzed projectiles, respectively, were exactly the same and are shown in figures 6, 7 and 8, respectively. The test array, in all three cases, consisted of five test units (each a single item) aligned in a straight line on a pine board configured the same as in the preceding paragraph. Again, in all cases, the center test unit was initiated as the donor and the two acceptors on each side were examined for propagation of the donor detonation. For the second hardware configuration, a total of four exploratory tests and 25 confirmatory tests were conducted; the third hardware configuration utilized a total of two exploratory tests followed by 25 confirmatory tests to determine the safe spacing; and the fifth hardware configuration had a total of 32 exploratory tests followed by 30 confirmatory tests. None of these tests utilized witness plates since post-test analysis of projectile body damage was sufficient to determine the extent of detonation propagation.

The test arrangements for the fourth hardware configuration, loaded body assemblies heated to 96°C (205°F), is shown in figures 9 and 10. Figure 9 is the five-unit test array and figure 10 is the same array with the disposable oven in-place. The disposable oven consisted of an expanded polystyrene plastic container, lined with aluminum foil (both inside and out), and containing three each 250-watt light bulbs for heating. A thermocouple was inserted into one of the acceptors to determine the temperature rise. A total of 21 exploratory and 25 confirmatory tests were conducted utilizing this test array.

The test arrangements for the sixth hardware configuration, fuzed projectiles aligned and heated, utilized the same disposable oven as described above. Figure 11 shows the alignment of the donor (left) and acceptor (right) projectiles. The wires to the left projectile are for ignition and to the right projectile for temperature determination. A series of 12 tests were conducted utilizing this test array.

## Methods of Initiation

For hardware configurations 1 through 5 inclusive, where all the test specimens were arrayed in a vertical alignment, a J2 electric blasting cap was used to initiate the donor specimen to a high order detonation. In hardware configuration 1 (the bare PBXN-5 pellets), the blasting cap was inserted 12.7 millimeters (0.5 inch) into the core hole of the top pellet. This same top-pellet-to-blasting-cap relationship was maintained for hardware configuration 2, where the loose pellets are contained within the shell body. For hardware configurations 3, 4 and 5, the blasting cap was placed in-line and directly on top of the 0.08-grain PBNX-5 relay charge. In hardware configuration 5 (fuzed projectiles), the donor specimen was deliberately left unfuzed for the insertion of the blasting cap (fig. 8).

Hardware configuration 6 (fuzed projectiles positioned horizontally nose to tail) presented a unique initiation problem since the shaped charge jet of the donor would affect the acceptor specimen. Preliminary tests utilizing both J2 and M6 electric blasting caps (figs. 12 and 13) resulted in failure since the force of the initiating cap destroyed the fluted liner before the jet could form; therefore, a special ignition device was factory-inserted into the donor projectiles for this test series (fig. 11).

## TEST RESULTS

### General

As previously mentioned, the safe separation distance tests on the 30MM XM789 HEDP Projectile were grouped into six hardware configurations representing various positions on the projectile's LAP loading line; i.e., bare PBXN-5 pellets (two each), shell body with loose pellets, loaded body assembly, heated loaded body assembly, fuzed projectile and heated fuzed projectile. The results of each individual hardware configuration test series are presented in tables 1 through 6, respectively. In addition, a summary of the results of the confirmatory tests on each hardware configuration along with its propagation probability is presented as table 7.

### Results of Individual Test Series

#### Hardware Configuration 1 - Bare PBXN-5 Pellets

The separation distances utilized in the exploratory testing phase of this hardware configuration ranged from a minimum spacing of 12.7 millimeters (0.5 inch) to a maximum of 50.8 millimeters (2.0 inches), measured edge to edge on the stacked pellets (fig. 5). The only high order propagations of the donor detonation were observed at the 12.7-millimeter (0.5-inch) spacing; therefore, after conducting six exploratory tests (tests nos. 1 to 6 inclusive of table 1), a non-propagation distance of 25.6 millimeters (1.0 inch) was established.

A total of 26 confirmatory tests were then performed at a safe separation distance of 25.4 millimeters (1.0 inch). The results show that no propagation of the donor's high detonation reached the acceptor pellet stacks (table 1, tests 7 through 32 inclusive). Figures 14 and 15 are examples of the post-test results. Figure 14 is a witness plate from the non-propagation of the donor detonation (note the large pieces of recovered pellets and only the donor imprint on the plate). Figure 15 is a similar witness plate; however, the donor detonation propagated on all the acceptors, as indicated by the detonation imprints on the plate.

#### Hardware Configuration 2 - Shell Body with Loose Pellets

In the exploratory phase for the second hardware configuration, the separation distances between shell bodies containing two loose PBXN-5 pellets each, ranged from 50.8 millimeters (2.0 inches) down to a minimum separation of 12.7 millimeters (0.5 inch), measured edge to edge on the shell bodies. Again, detonation occurred at a spacing of 12.7 millimeters (0.5 inch). Therefore, after conducting only three exploratory tests (table 2, tests 1 through 3 inclusive), a non-propagation distance of 25.4 millimeters (1.0 inch) was established.

The confirmatory test phase for the second hardware configuration consisted of 26 tests (table 2, tests 4 through 29 inclusive) utilizing the layout shown in figure 6 and a safe separation distance of 25.4 millimeters (1.0 inch). Post-test analysis indicated numerous low order propagations to the nearest acceptors (nos. 2 and 4); however, in all the confirmatory tests, the outer acceptors (nos. 1 and 5) were not only never damaged, but were also reusable from

test to test. Figure 16 is a post-test view of the assembled acceptors placed in their relative test positions (note the minimal damage to acceptors 1 and 5, and the collected low order debris from acceptors 2 and 4).

#### Hardware Configuration 3 - Loaded Body Assembly

The third hardware configuration exploratory test phase utilized separation distances ranging from 12.7 millimeters (0.5 inch) up to a maximum of 25.4 millimeters (1.0 inch). The only high order propagations of all the acceptors by the donor detonation were recorded at the 12.7-millimeter (0.5-inch) spacing; therefore, after only two exploratory tests (table 3, tests 1 and 2), a non-propagation distance 25.4 millimeters (1.0 inch) was established.

A total of 25 confirmatory tests were conducted utilizing the third hardware configuration and the established safe separation distance of 25.4 millimeters (1.0 inch) without a single donor detonation propagating to the outer acceptors (nos. 1 and 5 of fig. 7). Post-test analysis of the recovered components led to the conclusion that, in most cases, the high order donor detonation propagated, but degraded to a low order detonation of the nearest acceptors (nos. 2 and 4), with never any damage to the outer acceptors (nos. 1 and 5). Figure 17 is a post-test view of the collected loaded body assembly acceptors positioned in their pre-test order.

#### Hardware Configuration 4 - Heated Loaded Body Assembly

The fourth hardware configuration had a total of 21 exploratory tests utilizing separation distances from 50.8 millimeters (2.0 inches) up to 76.2 millimeters (3.0 inches) with the only high order propagation occurring at the 50.8-millimeter (2.0-inch) spacing. Therefore, a non-propagation distance was established at 76.2 millimeters (3.0 inches) and a series of 25 confirmatory tests were conducted without propagation being recorded. Figure 18 is a post-test view of the fourth hardware configuration (note the lack of damage to the outer acceptors). The data summary for this test is shown in table 4.

#### Hardware Configuration 5 - Fuzed Projectile

The separation distances utilized in the exploratory testing phase of hardware configuration 5 ranged from a minimum spacing of 12.7 millimeters (0.5 inch) to a maximum of 76.2 millimeters (3.0 inches), measured edge to edge on the fuzed projectile's body (fig. 8). High order propagations of the donor's detonation to all acceptors were experienced at distances from 12.7 millimeters (0.5 inch) up to and including 50.8 millimeters (2.0 inches); therefore, after conducting 31 exploratory tests (table 5, nos. 1 to 31 inclusive), a non-propagation distance of 76.2 millimeters (3.0 inches) was established.

The confirmatory test phase for the fifth hardware configuration consisted of 30 tests (table 5, nos. 32 through 61 inclusive), utilizing the test layout shown in figure 8 and a safe separation distance of 76.2 millimeters (3.0 inches). Post-test analysis indicated numerous low order propagations of the high order donor detonations to the nearer acceptor projectiles (nos. 2 and 4); however, in all the confirmatory tests, the outer acceptors (nos. 1 and 5) were never damaged, but were reusable from test to test. Figure 19 and 20 are examples of post-test results.

Figure 19 is an example where the inner or nearer acceptor sustained heavy damage, while the outer acceptors were completely undamaged. Figure 20 is an example where the inner acceptors functioned with a low order detonation, again with no damage to the outer acceptors [note in fig. 20 the sequential impressions on the witness plate of the donor detonation (high order) hole as compared to the low order detonation markings of the inner acceptors].

#### Hardware Configuration 6 - Heated Fuzed Projectile

The sixth hardware configuration, heated and aligned fuzed projectile, had only 12 tests conducted. Separation distances were varied from a minimum of 76.2 millimeters (3.0 inches) to a maximum of 381 millimeters (15.0 inches) with high order detonations occurring at all test distances (table 6). Since the maximum distance exceeded allowable distances on the proposed assembly line, the testing of the aligned projectiles was discontinued. Figure 21 is a post-test view of the complete destruction of the acceptor and figure 22 is another post-view showing the "jet" penetration of the acceptor.

#### Summary of Test Results

While a few high order propagations of the donor detonations were observed during the exploratory phases of all six hardware configurations, the confirmatory test results clearly showed that no propagations occurred at the established safe separation distances despite numerous low order propagations to the nearer acceptors. The established clear safe separation distances are:

25.4 millimeters (1.0 inch) for hardware configuration 1, the stacks of two each bare PBXN-5 pellets;

25.4 millimeters (1.0 inch) for hardware configuration 2, the shell bodies with two loose pellets in them;

25.4 millimeters (1.0 inch) for hardware configuration 3, the fully loaded body assemblies;

76.2 millimeters (3.0 inches) for hardware configuration 4, the fully loaded body assemblies heated to 96°C (205°F);

76.2 millimeters (3.0 inches) for hardware configuration 5, the fuzed projectile, and

greater than 381.0 millimeters (15.0 inches) for hardware configuration 6, the fuzed projectile heated to 96°C (205°F).

#### Analysis of Test Results

Variation in manufacturing tolerances, materials, wear, etc., requires that statistical reasoning be enlisted in the interpretation of the test results in establishing the safe separation distances. The actual probability of the propagation of an explosive incident is a direct function of the number of

propagation occurrences in a particular test phase as related to the total number of tests conducted (see appendix for the detailed statistical theory).

In the first hardware configuration, bare PBXN-5 pellets spaced 25.4 millimeters (1.0 inch) apart, a total of 52 acceptor points were recorded (26 test firings) without the propagation of an explosive incident. Therefore, the probability of a detonation of an acceptor by a donor initiation is 6.94 percent at the 95 percent confidence level.

In the second hardware configuration, shell bodies containing loose pellets, the test units were also spaced 25.4 millimeters (1.0 inch) apart. Again, a total of 54 acceptor data points were recorded (27 test firings) without the propagation of an explosive incident. This produces a probability of detonation of an acceptor unit by a donor initiation of 6.60 percent at the 95 percent confidence level.

For the third hardware configuration, loaded body assemblies, the spacing was also 25.4 millimeters (1.0 inch), with a total of 50 acceptor data points (25 test firings) being recorded without a propagation of a donor detonation to an acceptor unit. The resultant probability of the sympathetic detonation of an acceptor unit by a donor initiation was 7.10 percent at the 95 percent confidence level.

In the fourth hardware configuration, loaded body assemblies heated to 96°C (205°F), a spacing of 76.2 millimeters (3.0 inches) was maintained between test units for a total of 25 tests, resulting in 50 acceptor data points without the propagation of the donor detonation to an acceptor unit. This produced a probability of detonation propagation from a donor to an acceptor of 7.10 percent at the 95 percent confidence level.

The fifth hardware configuration, consisting of 30MM XM789 HEDP Projectiles with XM714E6 PD Fuzes spaced 76.2 millimeters (3.0 inches) apart, had a total of 60 data points recorded (30 test firings) without a propagation of an explosive incident. Therefore, the probability of a detonation of an acceptor by a donor initiation is 5.97 percent at the 95 percent confidence level.

In the sixth hardware configuration, fuzed projectiles heated to 96°C (205°F) and aligned, no safe separation distance was established. The only fact established during this test phase was that all distances up to and including 381.0 millimeters (15.0 inches) on aligned projectiles will propagate.

For the probability of propagation of an explosive incident, five of the six hardware configuration values are equivalent to stating that in any large number of tests, 95 out of 100 times, the probability of the propagation to an explosive event will be less than, or equal to, the stated probability values. These values indicate the quality of the test results and the reliance that can be placed upon the conclusions drawn from the resultant data.

## CONCLUSIONS AND RECOMMENDATIONS

It may be concluded from the confirmatory test results of all six hardware configurations that the established minimum non-propagating safe separation distances listed in table 7 are adequate to protect the 30MM XM789 HEDP Projectile LAP operation from catastrophic effects of an accidental explosive incident, and that the proposed final assembly conveying system should be structured to prevent any possible axial alignment of the projectiles.

Table 1. Test data summary - Bare PBXN-5 pellets - 2 per unit

(Hardware Configuration #1)

Test No.	Acceptors	Separation mm (in)	Results
1	Left Right	12.7 (0.5) 12.7 (0.5)	No witness plates were used and the acceptors were completely pulverized; therefore, the propagation results are unknown.
2	Left Right	25.4 (1.0) 25.4 (1.0)	Same as above.
3	Left Right	50.8 (2.0) 50.8 (2.0)	Same as above.
4	Left Right	25.4 (1.0) 25.4 (1.0)	NDP <sup>a</sup> , all pellets pulverized NDP, all pellets pulverized
5	Left Right	12.7 (0.5) 12.7 (0.5)	HOD <sup>b</sup> , all pellets HOD, all pellets
6	Left Right	12.7 (0.5) 12.7 (0.5)	HOD, all pellets HOD, all pellets
7	Left Right	25.4 (1.0) 25.4 (1.0)	NDP, all pellets pulverized NDP, all pellets pulverized
8	Left Right	25.4 (1.0) 25.4 (1.0)	NDP NDP
9	Left Right	25.4 (1.0) 25.4 (1.0)	NDP NDP
10	Left Right	25.4 (1.0) 25.4 (1.0)	NDP NDP
11	Left Right	25.4 (1.0) 25.4 (1.0)	NDP NDP
12	Left Right	25.4 (1.0) 25.4 (1.0)	NDP NDP
13	Left Right	25.4 (1.0) 25.4 (1.0)	NDP NDP
14	Left Right	25.4 (1.0) 25.4 (1.0)	NDP NDP

Table 1. (cont)

Test No.	Acceptors	Separation		Results
		mm	(in)	
15	Left	25.4	(1.0)	NDP
	Right	25.4	(1.0)	NDP
16	Left	25.4	(1.0)	NDP
	Right	25.4	(1.0)	NDP
17	Left	25.4	(1.0)	NDP
	Right	25.4	(1.0)	NDP
18	Left	25.4	(1.0)	NDP
	Right	25.4	(1.0)	NDP
19	Left	25.4	(1.0)	NDP
	Right	25.4	(1.0)	NDP
20	Left	25.4	(1.0)	NDP
	Right	25.4	(1.0)	NDP
21	Left	25.4	(1.0)	NDP
	Right	25.4	(1.0)	NDP
22	Left	25.4	(1.0)	NDP
	Right	25.4	(1.0)	NDP
23	Left	25.4	(1.0)	NDP
	Right	25.4	(1.0)	NDP
24	Left	25.4	(1.0)	NDP
	Right	25.4	(1.0)	NDP
25	Left	25.4	(1.0)	NDP
	Right	25.4	(1.0)	NDP
26	Left	25.4	(1.0)	NDP
	Right	25.4	(1.0)	NDP
27	Left	25.4	(1.0)	NDP
	Right	25.4	(1.0)	NDP
28	Left	25.4	(1.0)	NDP
	Right	25.4	(1.0)	NDP
29	Left	25.4	(1.0)	NDP
	Right	25.4	(1.0)	NDP

Table 1. (cont)

<u>Test No.</u>	<u>Acceptors</u>	<u>Separation mm (in)</u>	<u>Results</u>
30	Left	25.4 (1.0)	NDP
	Right	25.4 (1.0)	NDP
31	Left	25.4 (1.0)	NDP
	Right	25.4 (1.0)	NDP
32	Left	25.4 (1.0)	NDP
	Right	25.4 (1.0)	NDP

---

<sup>a</sup> NDP - No Detonation Propagation from donor to acceptors.

<sup>b</sup> HOD - High Order Detonation of acceptors.

Table 2. Test data summary - Shell body with 2 loose PBXN-5 pellets  
(Hardware Configuration #2)

Test No.	Acceptors	Separation mm (in)		Results
1	Left	50.8	(2.0)	NDP <sup>a</sup> , pellets crushed in #2 <sup>b</sup>
	Right	50.8	(2.0)	NDP, pellets crushed in #4
2	Left	12.7	(0.5)	HOD <sup>c</sup> all pellets
	Right	12.7	(0.5)	HOD all pellets
3	Left	25.4	(1.0)	LOD <sup>d</sup> #2, NDP and pellet cracked #1
	Right	25.4	(1.0)	LOD #4, NDP #5
4	Left	25.4	(1.0)	LOD #2, NDP #1
	Right	25.4	(1.0)	LOD #4, NDP and pellet cracked #5
5	Left	25.4	(1.0)	LOD #2, NDP and broken pellets <sup>e</sup> #1
	Right	25.4	(1.0)	LOD #4, NDP and broken pellets #5
6	Left	25.4	(1.0)	LOD #2, NDP and cracked pellets <sup>f</sup> #1
	Right	25.4	(1.0)	LOD #4, NDP and cracked pellets #5
7	Left	25.4	(1.0)	LOD #2, NDP and cracked pellets #1
	Right	25.4	(1.0)	LOD #4, NDP and cracked pellets #5
8	Left	25.4	(1.0)	LOD #2, NDP #1
	Right	25.4	(1.0)	LOD #4, NDP #5
9	Left	25.4	(1.0)	LOD #2, NDP #1
	Right	25.4	(1.0)	LOD #4, NDP #5
10	Left	25.4	(1.0)	LOD #2, NDP and cracked pellets #1
	Right	25.4	(1.0)	LOD #4, NDP #5
11	Left	25.4	(1.0)	NDP and pulverized pellets <sup>g</sup> #2, NDP #1
	Right	25.4	(1.0)	LOD #4, NDP #5
12	Left	25.4	(1.0)	LOD #2, NDP #1
	Right	25.4	(1.0)	LOD #4, NDP #5
13	Left	25.4	(1.0)	LOD #2, NDP #1
	Right	25.4	(1.0)	LOD #4, NDP #5
14	Left	25.4	(1.0)	LOD #2, NDP #1
	Right	25.4	(1.0)	LOD #4, NDP #5

Table 2. (cont)

Test No.	Acceptors	Separation mm (in)		Results
15	Left	25.4	(1.0)	LOD #2, NDP #1
	Right	25.4	(1.0)	LOD #4, NDP #5
16	Left	25.4	(1.0)	LOD #2, NDP #1
	Right	25.4	(1.0)	LOD #4, NDP #5
17	Left	25.4	(1.0)	LOD #2, NDP #1
	Right	25.4	(1.0)	LOD #4, NDP #5
18	Left	25.4	(1.0)	LOD #2, NDP and cracked pellets #1
	Right	25.4	(1.0)	LOD #4, NDP #5
19	Left	25.4	(1.0)	LOD #2, NDP #1
	Right	25.4	(1.0)	NDP and pulverized pellets #4, NDP #5
20	Left	25.4	(1.0)	LOD #2, NDP #1
	Right	25.4	(1.0)	LOD #4, NDP #5
21	Left	25.4	(1.0)	LOD #2, NDP #1
	Right	25.4	(1.0)	LOD #4, NDP #5
22	Left	25.4	(1.0)	LOD #2, NDP #1
	Right	25.4	(1.0)	LOD #4, NDP and cracked pellets #5
23	Left	25.4	(1.0)	LOD #2, NDP and cracked pellets #1
	Right	25.4	(1.0)	LOD #4, NDP and cracked pellets #5
24	Left	25.4	(1.0)	LOD #2, NDP #1
	Right	25.4	(1.0)	LOD #4, NDP and cracked pellets #5
25	Left	25.4	(1.0)	NDP and pulverized pellets #2, NDP #1
	Right	25.4	(1.0)	LOD #4, NDP #5
26	Left	25.4	(1.0)	LOD #2, NDP and cracked pellets #1
	Right	25.4	(1.0)	LOD #4, NDP and cracked pellets #5
27	Left	25.4	(1.0)	LOD #2, NDP and cracked pellets #1
	Right	25.4	(1.0)	LOD #4, NDP and cracked pellets #5
28	Left	25.4	(1.0)	LOD #2, NDP #1
	Right	25.4	(1.0)	LOD #4, NDP #5
29	Left	25.4	(1.0)	LOD #2, NDP #1
	Right	25.4	(1.0)	NDP and pulverized pellets #4, NDP #5

Table 2. (cont)

- 
- a NDP - No Detonation Propagation.
  - b Numbers refer to position order from left to right: acceptor #1, acceptor #2, donor #3, acceptor #4 and acceptor #5.
  - c HOD - High Order Detonation.
  - d LOD - Low Order Detonation.
  - e Broken pellets - Pellet is broken into large pieces.
  - f Cracked pellets - Pellet is still whole but has visible cracks in it.
  - g Pulverized pellets - Pellet is completely broken up into a fine powder.

Table 3. Test data summary - Loaded body assembly  
(Hardware Configuration #3)

Test No.	Acceptors	Separation mm (in)	Results
1	Left Right	25.4 (1.0) 25.4 (1.0)	LOD <sup>a</sup> #2 <sup>b</sup> , NDP <sup>c</sup> #1 LOD #4, NDP #5
2	Left Right	12.7 (0.5) 12.7 (0.5)	HOD <sup>d</sup> both acceptors HOD both acceptors
3	Left Right	25.4 (1.0) 25.4 (1.0)	LOD #2, NDP #1 LOD #4, NDP #5
4	Left Right	25.4 (1.0) 25.4 (1.0)	LOD #2, NDP #1 LOD #4, NDP #5
5	Left Right	25.4 (1.0) 25.4 (1.0)	LOD #2, NDP #1 LOD #4, NDP #5
6	Left Right	25.4 (1.0) 25.4 (1.0)	LOD #2, NDP #1 LOD #4, NDP #5
7	Left Right	25.4 (1.0) 25.4 (1.0)	LOD #2, NDP #1 LOD #4, NDP #5
8	Left Right	25.4 (1.0) 25.4 (1.0)	LOD #2, NDP #1 LOD #4, NDP #5
9	Left Right	25.4 (1.0) 25.4 (1.0)	LOD #2, NDP #1 LOD #4, NDP #5
10	Left Right	25.4 (1.0) 25.4 (1.0)	LOD #2, NDP #1 LOD #4, NDP #5
11	Left Right	25.4 (1.0) 25.4 (1.0)	LOD #2, NDP #1 LOD #4, NDP #5
12	Left Right	25.4 (1.0) 25.4 (1.0)	LOD #2, NDP #1 LOD #4, NDP #5
13	Left Right	25.4 (1.0) 25.4 (1.0)	LOD #2, NDP #1 LOD #4, NDP #5
14	Left Right	25.4 (1.0) 25.4 (1.0)	LOD #2, NDP #1 LOD #4, NDP #5
15	Left Right	25.4 (1.0) 25.4 (1.0)	LOD #2, NDP #1 LOD #4, NDP #5

Table 3. (cont)

Test No.	Acceptors	Separation		Results
		mm	(in)	
16	Left	25.4	(1.0)	LOD #2, NDP #1
	Right	25.4	(1.0)	LOD #4, NDP #5
17	Left	25.4	(1.0)	NDP #2 and #1
	Right	25.4	(1.0)	LOD #4, NDP #5
18	Left	25.4	(1.0)	LOD #2, NDP #1
	Right	25.4	(1.0)	LOD #4, NDP #5
19	Left	25.4	(1.0)	LOD #2, NDP #1
	Right	25.4	(1.0)	LOD #4, NDP #5
20	Left	25.4	(1.0)	LOD #2, NDP #1
	Right	25.4	(1.0)	LOD #4, NDP #5
21	Left	25.4	(1.0)	LOD #2, NDP #1
	Right	25.4	(1.0)	NDP #4 and #5
22	Left	25.4	(1.0)	LOD #2, NDP #1
	Right	25.4	(1.0)	LOD #4, NDP #5
23	Left	25.4	(1.0)	LOD #2, NDP #1
	Right	25.4	(1.0)	LOD #4, NDP #5
24	Left	25.4	(1.0)	LOD #2, NDP #1
	Right	25.4	(1.0)	LOD #4, NDP #5
25	Left	25.4	(1.0)	LOD #2, NDP #1
	Right	25.4	(1.0)	LOD #4, NDP #5
26	Left	25.4	(1.0)	NDP #1 and #2
	Right	25.4	(1.0)	NDP #4 and #5
27	Left	25.4	(1.0)	LOD #2, NDP #1
	Right	25.4	(1.0)	LOD #4, NDP #5

a LOD - Low Order Detonation.

b Numbers refer to position order from left to right: acceptor #1, acceptor #2, donor #3, acceptor #4 and acceptor #5.

c NDP - No Detonation Propagation.

d HOD - High Order Detonation.

Table 4. Test data summary - Loaded body assembly - Heated

(Hardware Configuration #4)

Test No.	Acceptors	Separation mm (in)	Results
1	Left Right	50.8 (2.0) 50.8 (2.0)	NDP <sup>a</sup> #2 <sup>b</sup> with several hits, NDP #1 LOD <sup>c</sup> #4, NDP #5
2	Left Right	50.8 (2.0) 50.8 (2.0)	LOD #2, NDP #1 LOD #4, NDP #5
3	Left Right	50.8 (2.0) 50.8 (2.0)	LOD #2, NDP #1 LOD #4, NDP #5
4	Left Right	50.8 (2.0) 50.8 (2.0)	LOD #2, NDP #1 LOD #4, NDP #5
5	Left Right	50.8 (2.0) 50.8 (2.0)	LOD #2, NDP #1 LOD #4, NDP #5
6	Left Right	50.8 (2.0) 50.8 (2.0)	LOD #2, NDP #1 LOD #4, NDP #5
7	Left Right	50.8 (2.0) 50.8 (2.0)	LOD #2, NDP #1 LOD #4, NDP #5
8	Left Right	50.8 (2.0) 50.8 (2.0)	LOD #2, NDP #1 LOD #4, NDP #5
9	Left Right	50.8 (2.0) 50.8 (2.0)	LOD #2, NDP #1 LOD #4, NDP #5
10	Left Right	50.8 (2.0) 50.8 (2.0)	NDP #2 with many hits, NDP #1 LOD #4, NDP #5
11	Left Right	50.8 (2.0) 50.8 (2.0)	LOD #2, NDP #1 LOD #4, NDP #5
12	Left Right	50.8 (2.0) 50.8 (2.0)	LOD #2, NDP #1 LOD #4, NDP #5
13	Left Right	50.8 (2.0) 50.8 (2.0)	LOD #2, NDP #1 LOD #4, NDP #5
14	Left Right	50.8 (2.0) 50.8 (2.0)	LOD #2, NDP #1 LOD #4, NDP #5
15	Left Right	50.8 (2.0) 50.8 (2.0)	LOD #2, NDP #1 LOD #4, NDP #5

Table 4. (cont)

Test No.	Acceptors	Separation		Results
		mm	(in)	
16	Left	50.8	(2.0)	LOD #2, NDP #1
	Right	50.8	(2.0)	LOD #4, NDP #5
17	Left	50.8	(2.0)	NDP #2, NDP #1
	Right	50.8	(2.0)	LOD #4, NDP #5
18	Left	50.8	(2.0)	LOD #2, NDP #1
	Right	50.8	(2.0)	LOD #4, NDP #5
19	Left	50.8	(2.0)	LOD #2, NDP #1
	Right	50.8	(2.0)	LOD #4 with many hits, NDP #5
20	Left	50.8	(2.0)	LOD #2, NDP #1
	Right	50.8	(2.0)	LOD #4, NDP #5
21	Left	50.8	(2.0)	LOD #2, NDP #1
	Right	50.8	(2.0)	NDP #4 with many hits, HOD <sup>d</sup> #5
22	Left	76.2	(3.0)	NDP #2 with many hits, NDP #1
	Right	76.2	(3.0)	NDP #4 with many hits, NDP #5
23	Left	76.2	(3.0)	NDP #2 with many hits, NDP #1
	Right	76.2	(3.0)	LOD #4, NDP #5
24	Left	76.2	(3.0)	LOD #2, NDP #1
	Right	76.2	(3.0)	LOD #4, NDP #5
25	Left	76.2	(3.0)	NDP #2 with many hits, NDP #1
	Right	76.2	(3.0)	LOD #4, NDP #5
26	Left	76.2	(3.0)	NDP #2 with many hits, NDP #1
	Right	76.2	(3.0)	LOD #4, NDP #5
27	Left	76.2	(3.0)	LOD #2, NDP #1
	Right	76.2	(3.0)	LOD #4 with penetrations, NDP #5
28	Left	76.2	(3.0)	LOD #2, NDP #1
	Right	76.2	(3.0)	LOD #4, NDP #5
29	Left	76.2	(3.0)	LOD #2, NDP #1
	Right	76.2	(3.0)	NDP #4 with several hits, NDP #5
30	Left	76.2	(3.0)	LOD #2, NDP #1
	Right	76.2	(3.0)	NDP #4 with many hits, NDP #5

Table 4. (cont)

Test No.	Acceptors	Separation mm (in)	Results
31	Left Right	76.2 (3.0) 76.2 (3.0)	NDP #2 with many hits, NDP #1 LOD #4, NDP #5
32	Left Right	76.2 (3.0) 76.2 (3.0)	LOD #2, NDP #1 LOD #4, NDP #5
33	Left Right	76.2 (3.0) 76.2 (3.0)	LOD #2, NDP #1 LOD #4, NDP #5
34	Left Right	76.2 (3.0) 76.2 (3.0)	LOD #2, NDP #1 NDP #4 with many hits, NDP #5
35	Left Right	76.2 (3.0) 76.2 (3.0)	LOD #2, NDP #1 NDP #4 with several hits, NDP #5
36	Left Right	76.2 (3.0) 76.2 (3.0)	NDP #2 with many hits, NDP #1 LOD #4, NDP #5
37	Left Right	76.2 (3.0) 76.2 (3.0)	LOD #2, NDP #1 NDP #4 with several hits, NDP #5
38	Left Right	76.2 (3.0) 76.2 (3.0)	LOD #2, NDP #1 LOD #4, NDP #5
39	Left Right	76.2 (3.0) 76.2 (3.0)	NDP #2 with many hits, NDP #1 NDP #4 with many hits, NDP #5
40	Left Right	76.2 (3.0) 76.2 (3.0)	LOD #2, NDP #1 LOD #4, NDP #5
41	Left Right	76.2 (3.0) 76.2 (3.0)	LOD #2, NDP #1 LOD #4, NDP #5
42	Left Right	76.2 (3.0) 76.2 (3.0)	LOD #2, NDP #1 NDP #4 with several hits, NDP #5
43	Left Right	76.2 (3.0) 76.2 (3.0)	LOD #2, NDP #1 NDP #4 with many hits, NDP #5
44	Left Right	76.2 (3.0) 76.2 (3.0)	NDP #2 with many hits, NDP #1 NDP #4 with many hits, NDP #5
45	Left Right	76.2 (3.0) 76.2 (3.0)	NDP #2 with many hits, NDP #1 NDP #4 with many hits, NDP #5

Table 4. (cont)

<u>Test No.</u>	<u>Acceptors</u>	<u>Separation mm (in)</u>	<u>Results</u>
46	Left	76.2 (3.0)	LOD #2, NDP #1
	Right	76.2 (3.0)	NDP #4 with many hits, NDP #5

a NDP - No Detonation Propagation.

b Numbers refer to position order from left to right: acceptor #1, acceptor #2, donor #3, acceptor #4 and acceptor #5.

c LOD - Low Order Detonation.

d HOD - High Order Detonation.

Table 5. Test data summary - 30MM XM789 HEDP Projectile with XM714E6 PD Fuze

(Hardware Configuration #5)

Test No.	Acceptors	Separation mm (in)	Results
1	Left Right	12.7 (0.5) 12.7 (0.5)	LOD <sup>a</sup> #2 <sup>b</sup> , NDP <sup>c</sup> and minor hit #1 HOD <sup>d</sup> #4 and #5
2	Left Right	25.4 (1.0) 25.4 (1.0)	LOD #2, NDP #1 LOD #4, NDP #5
3	Left Right	25.4 (1.0) 25.4 (1.0)	LOD #2, NDP #1 LOD #4, NDP #5
4	Left Right	25.4 (1.0) 25.4 (1.0)	LOD #2, NDP #1 LOD #4, NDP #5
5	Left Right	25.4 (1.0) 25.4 (1.0)	LOD #2, NDP #1 LOD #4, NDP #5
6	Left Right	25.4 (1.0) 25.4 (1.0)	LOD #2, NDP #1 LOD #4, NDP #5
7	Left Right	25.4 (1.0) 25.4 (1.0)	LOD #2, NDP #1 LOD #4, NDP #5
8	Left Right	25.4 (1.0) 25.4 (1.0)	LOD #2, NDP #1 LOD #4, NDP #5
9	Left Right	25.4 (1.0) 25.4 (1.0)	LOD #2, NDP #1 LOD #4, NDP #5
10	Left Right	25.4 (1.0) 25.4 (1.0)	LOD #2, NDP #1 LOD #4, NDP #5
11	Left Right	25.4 (1.0) 25.4 (1.0)	LOD #2, NDP #1 LOD #4, NDP #5
12	Left Right	25.4 (1.0) 25.4 (1.0)	LOD #2, NDP #1 LOD #4, NDP #5
13	Left Right	25.4 (1.0) 25.4 (1.0)	LOD #2, NDP #1 LOD #4, NDP #5
14	Left Right	25.4 (1.0) 25.4 (1.0)	LOD #2, NDP #1 LOD #4, NDP #5
15	Left Right	25.4 (1.0) 25.4 (1.0)	LOD #2, NDP #1 LOD #4, NDP #5

Table 5. (cont)

Test No.	Acceptors	Separation mm (in)	Results
16	Left	25.4 (1.0)	LOD #2, NDP #1
	Right	25.4 (1.0)	LOD #4, NDP #5
17	Left	25.4 (1.0)	LOD #2, NDP #1
	Right	25.4 (1.0)	LOD #4, NDP #5
18	Left	25.4 (1.0)	LOD #2, NDP #1
	Right	25.4 (1.0)	LOD #4, NDP #5
19	Left	25.4 (1.0)	LOD #2, NDP #1
	Right	25.4 (1.0)	LOD #4, NDP #5
20	Left	25.4 (1.0)	LOD #2, NDP #1
	Right	25.4 (1.0)	LOD #4, NDP #5
21	Left	25.4 (1.0)	LOD #2, NDP #1
	Right	25.4 (1.0)	LOD #4, NDP #5
22	Left	25.4 (1.0)	LOD #2, NDP #1
	Right	25.4 (1.0)	LOD #4, NDP #5
23	Left	25.4 (1.0)	LOD #2, NDP #1
	Right	25.4 (1.0)	LOD #4, NDP #5
24	Left	25.4 (1.0)	LOD #2, NDP #1
	Right	25.4 (1.0)	LOD #4, NDP #5
25	Left	50.8 (2.0)	LOD #2, NDP #1
	Right	50.8 (2.0)	NDP and several hits #4, NDP #5
26	Left	50.8 (2.0)	NDP and several hits #2, NDP #1
	Right	50.8 (2.0)	NDP and several hits #4, NDP #5
27	Left	50.8 (2.0)	LOD #2, NDP #1
	Right	50.8 (2.0)	LOD #4, NDP #5
28	Left	50.8 (2.0)	NDP and several hits #2, NDP #1
	Right	50.8 (2.0)	NDP and several hits #4, NDP #5
29	Left	50.8 (2.0)	NDP and heavy damage #2, NDP #1
	Right	50.8 (2.0)	NDP and heavy damage #4, NDP #5
30	Left	50.8 (2.0)	LOD #2, NDP #1
	Right	50.8 (2.0)	LOD #4, NDP #5

Table 5. (cont)

Test No.	Acceptors	Separation		Results
		mm	(in)	
31	Left	50.8	(2.0)	LOD #2, NDP #1 NDP and heavy damage #4, HOD #5
	Right	50.8	(2.0)	
32	Left	76.2	(3.0)	LOD #2, NDP #1 LOD #4, NDP #5
	Right	76.2	(3.0)	
33	Left	76.2	(3.0)	LOD #2, NDP #1 LOD #4, NDP #5
	Right	76.2	(3.0)	
34	Left	76.2	(3.0)	LOD #2, NDP #1 NDP and heavy damage #4, NDP #5
	Right	76.2	(3.0)	
35	Left	76.2	(3.0)	LOD #2, NDP #1 LOD #4, NDP #5
	Right	76.2	(3.0)	
36	Left	76.2	(3.0)	LOD #2, NDP #1 LOD #4, NDP #5
	Right	76.2	(3.0)	
37	Left	76.2	(3.0)	LOD #2, NDP #1 LOD #4, NDP #5
	Right	76.2	(3.0)	
38	Left	76.2	(3.0)	LOD #2, NDP #1 LOD #4, NDP #5
	Right	76.2	(3.0)	
39	Left	76.2	(3.0)	NDP and heavy damage #2, NDP #1 NDP and heavy damage #4, NDP #5
	Right	76.2	(3.0)	
40	Left	76.2	(3.0)	LOD #2, NDP #1 NDP and heavy damage #4, NDP #5
	Right	76.2	(3.0)	
41	Left	76.2	(3.0)	NDP and heavy damage #2, NDP #1 LOD #4, NDP #5
	Right	76.2	(3.0)	
42	Left	76.2	(3.0)	NDP and heavy damage #2, NDP #1 LOD #4, NDP #5
	Right	76.2	(3.0)	
43	Left	76.2	(3.0)	LOD #2, NDP #1 NDP and penetrations #4, NDP #5
	Right	76.2	(3.0)	
44	Left	76.2	(3.0)	LOD #2, NDP #1 LOD #4, NDP #5
	Right	76.2	(3.0)	
45	Left	76.2	(3.0)	LOD #2, NDP #1 LOD #4, NDP #5
	Right	50.8	(2.0)	

Table 5. (cont)

Test No.	Acceptors	Separation		Results
		mm	(in)	
46	Left	76.2	(3.0)	NDP and heavy damage #2, NDP #1 LOD #4, NDP #5
	Right	76.2	(3.0)	
47	Left	76.2	(3.0)	LOD #2, NDP #1 LOD #4, NDP #5
	Right	76.2	(3.0)	
48	Left	76.2	(3.0)	NDP and heavy damage #2, NDP #1 LOD #4, NDP #5
	Right	76.2	(3.0)	
49	Left	76.2	(3.0)	LOD #2, NDP #1 NDP and heavy damage #4, NDP #5
	Right	76.2	(3.0)	
50	Left	76.2	(3.0)	NDP and heavy damage #2, NDP #1 LOD #4, NDP #5
	Right	76.2	(3.0)	
51	Left	76.2	(3.0)	LOD #2, NDP #1 NDP and heavy damage #4, NDP #5
	Right	76.2	(3.0)	
52	Left	76.2	(3.0)	NDP and heavy damage #2, NDP #1 NDP and several hits #4, NDP #5
	Right	76.2	(3.0)	
53	Left	76.2	(3.0)	LOD #2, NDP #1 LOD #4, NDP #5
	Right	76.2	(3.0)	
54	Left	76.2	(3.0)	NDP and several hits #2, NDP #1 NDP and several hits #4, NDP #5
	Right	76.2	(3.0)	
55	Left	76.2	(3.0)	LOD #2, NDP #1 NDP and several hits #4, NDP #5
	Right	76.2	(3.0)	
56	Left	76.2	(3.0)	NDP and several hits #2, NDP #1 NDP and several hits #4, NDP #5
	Right	76.2	(3.0)	
57	Left	76.2	(3.0)	LOD #2, NDP #1 NDP and heavy damage #4, NDP #5
	Right	76.2	(3.0)	
58	Left	76.2	(3.0)	LOD #2, NDP #1 LOD #4, NDP #5
	Right	76.2	(3.0)	
59	Left	76.2	(3.0)	LOD #2, NDP #1 LOD #4, NDP #5
	Right	76.2	(3.0)	
60	Left	76.2	(3.0)	NDP and several hits #2, NDP #1 LOD #4, NDP #5
	Right	50.8	(2.0)	

Table 5. (cont)

<u>Test No.</u>	<u>Acceptors</u>	<u>Separation mm (in)</u>	<u>Results</u>
61	Left	76.2 (3.0)	LOD #2, NDP #1
	Right	76.2 (3.0)	LOD #4, NDP #5

a LOD - Low Order Detonation.

b Numbers refer to position order from left to right: acceptor #1, acceptor #2, donor #3, acceptor #4 and acceptor #5.

c NDP - No Detonation Propagation.

d HOD - High Order Detonation.

Table 6. Test data summary - Fuzed Projectile - Horizontally aligned and heated  
 (Hardware Configuration #6)

Test No.	Separation		Results
	mm	(in)	
1	76.2	( 3.0)	HOD <sup>a</sup>
2	101.6	( 4.0)	HOD
3	127.0	( 5.0)	HOD
4	152.4	( 6.0)	HOD
5	177.8	( 7.0)	HOD
6	228.6	( 9.0)	HOD
7	304.8	(12.0)	NDP <sup>b</sup> , many hits and penetrations
8	381.0	(15.0)	NDP, many hits
9	381.0	(15.0)	NDP, many hits
10	381.0	(15.0)	NDP, many hits
11	381.0	(15.0)	NDP, many hits
12	381.0	(15.0)	HOD

<sup>a</sup> HOD - High Order Detonation of acceptors.

<sup>b</sup> NDP - No Detonation Propagation from donor to acceptors.

Table 7. Program results summary - 30MM XM789 HEDP Projectile

	<u>NUMBER OF TESTS</u>	<u>SEPARATION</u>		<u>PERCENTAGE (%)</u>
		<u>mm</u>	<u>(in)</u>	
Bare PBXN-5 Pellets - Two per Unit	52	25.4	(1.0)	6.84
Shell Body with Loose Pellets	54	25.4	(1.0)	6.60
Loaded Body Assembly	50	25.4	(1.0)	7.10
Heated Loaded Body Assembly	50	76.2	(3.0)	7.10
Fuzed Projectile	60	76.2	(3.0)	5.97
Heated Fuzed Projectile	12	> 381.0	(>15.0)	NA

PBXN-5  
 HMX ————— 95%  
 COPOLYMER ——— 5 %  
 VINYLENE FLUORIDE —(79%)  
 HEXAFLUROPROPYLENE —(21%)

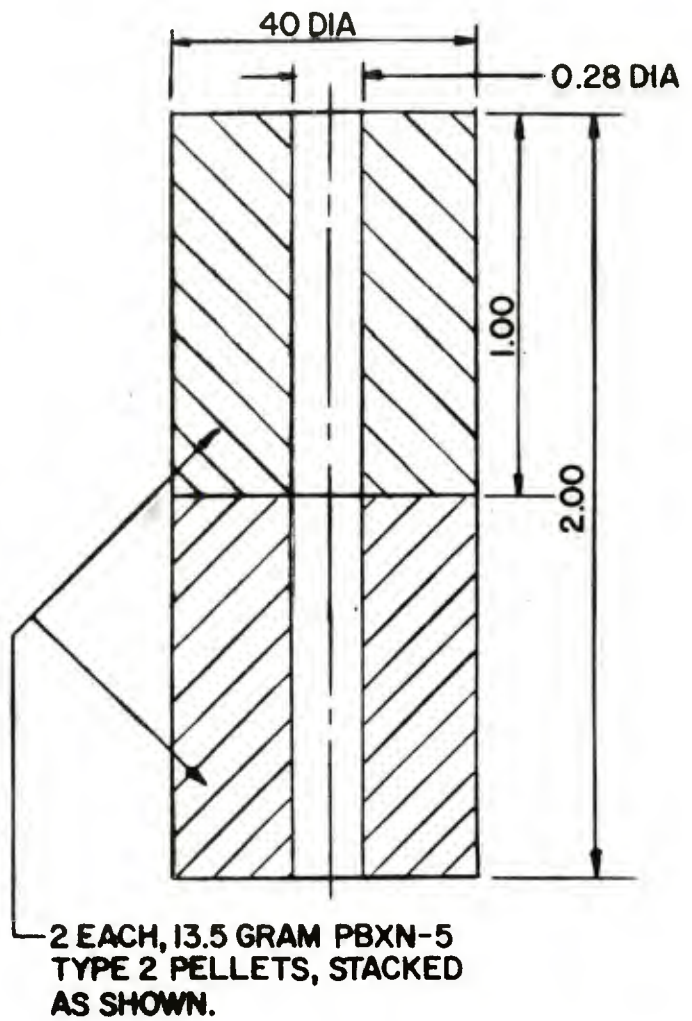

**FIGURE 1. 30MM XM789 HEDP Projectile hardware configuration  
 (bare PBXN-5 pellets)**

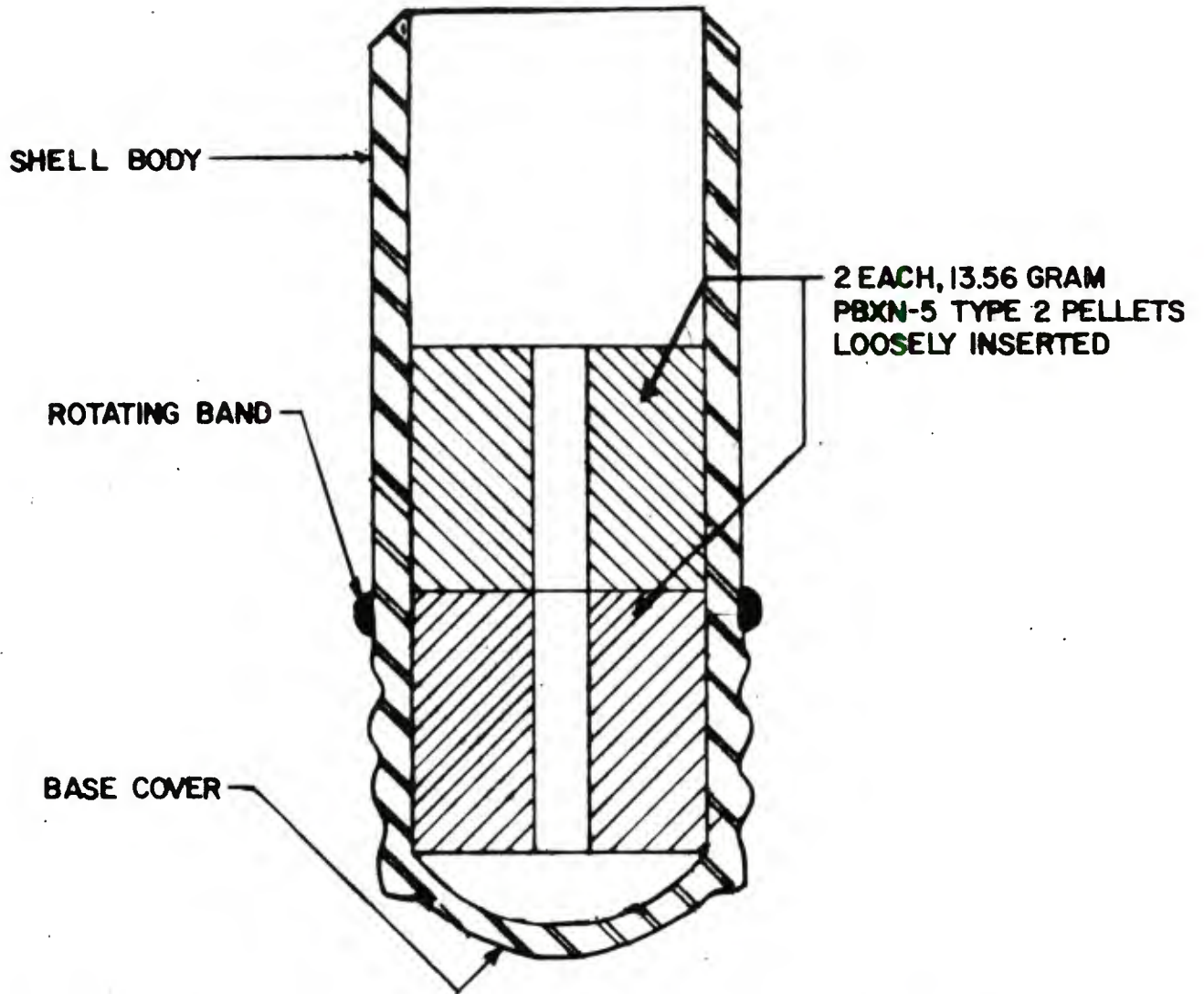

**FIGURE 2. 30MM XM789 HEDP Projectile hardware configuration 2 (shell body with loose pellets)**

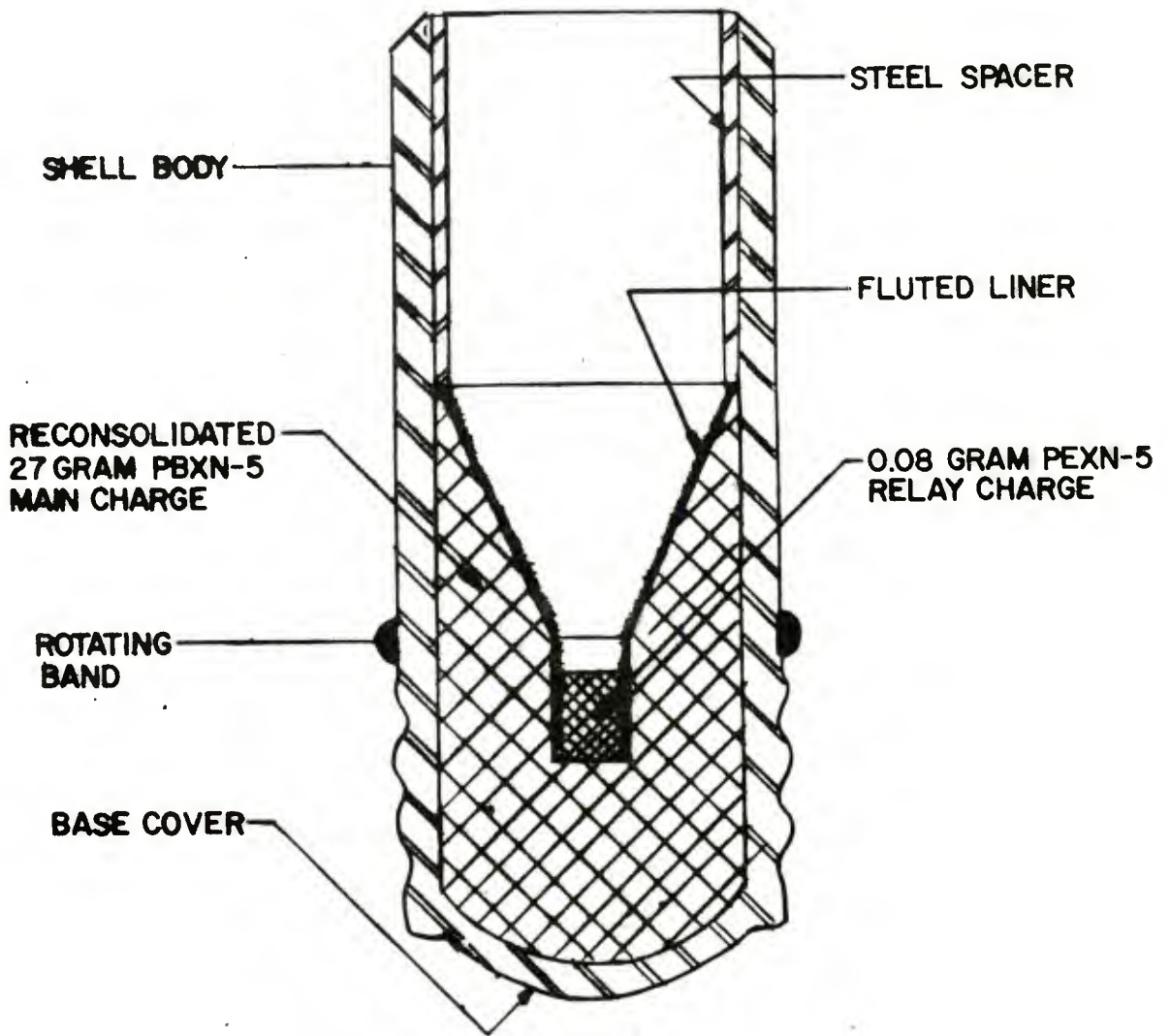

**FIGURE 3. 30MM XM789 HEDP Projectile hardware configuration 3 (loaded projectile body)**

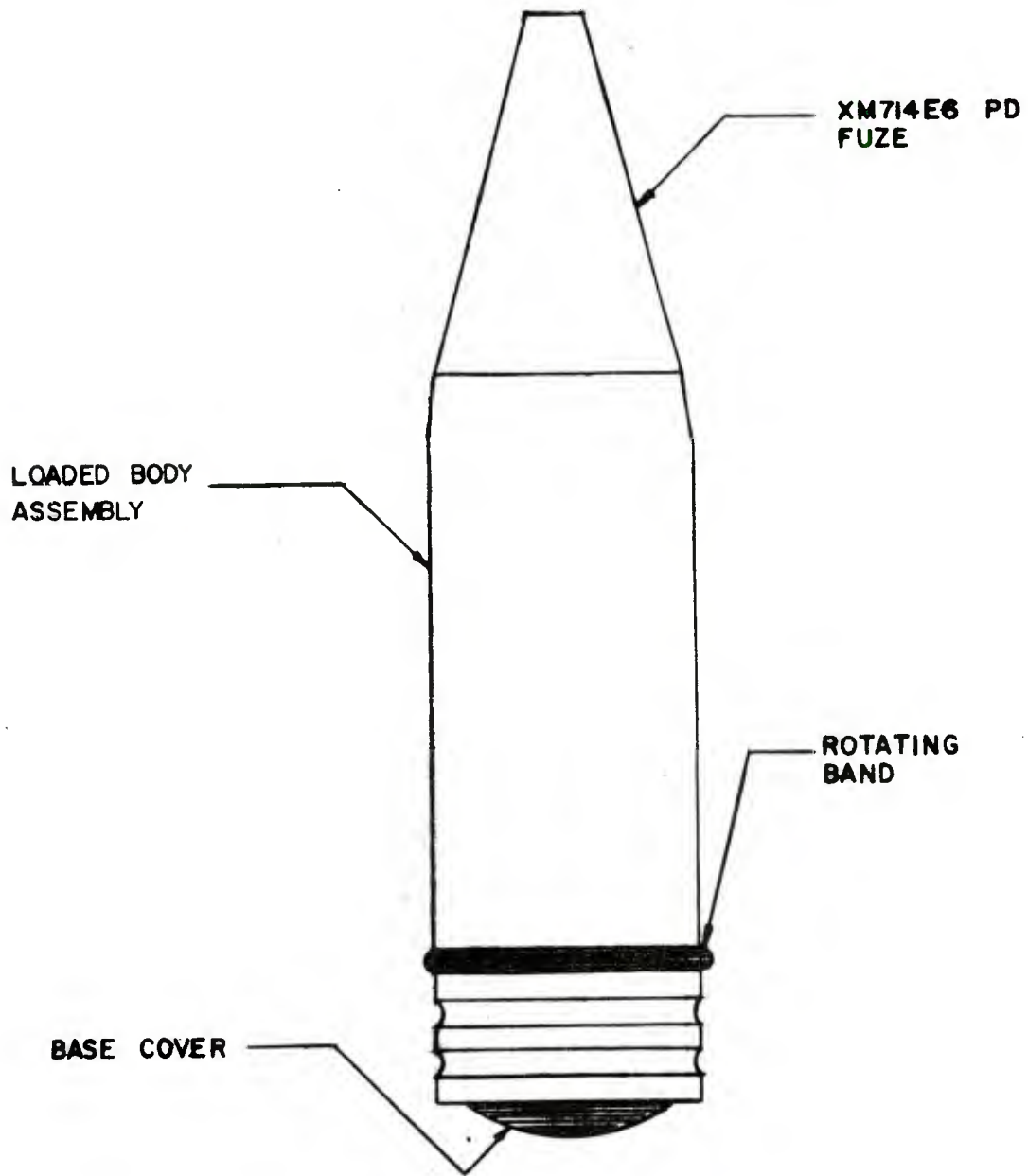

**FIGURE 4: 30MM XM789 HEDP Projectile hardware configuration 5  
(fuzed projectile)**

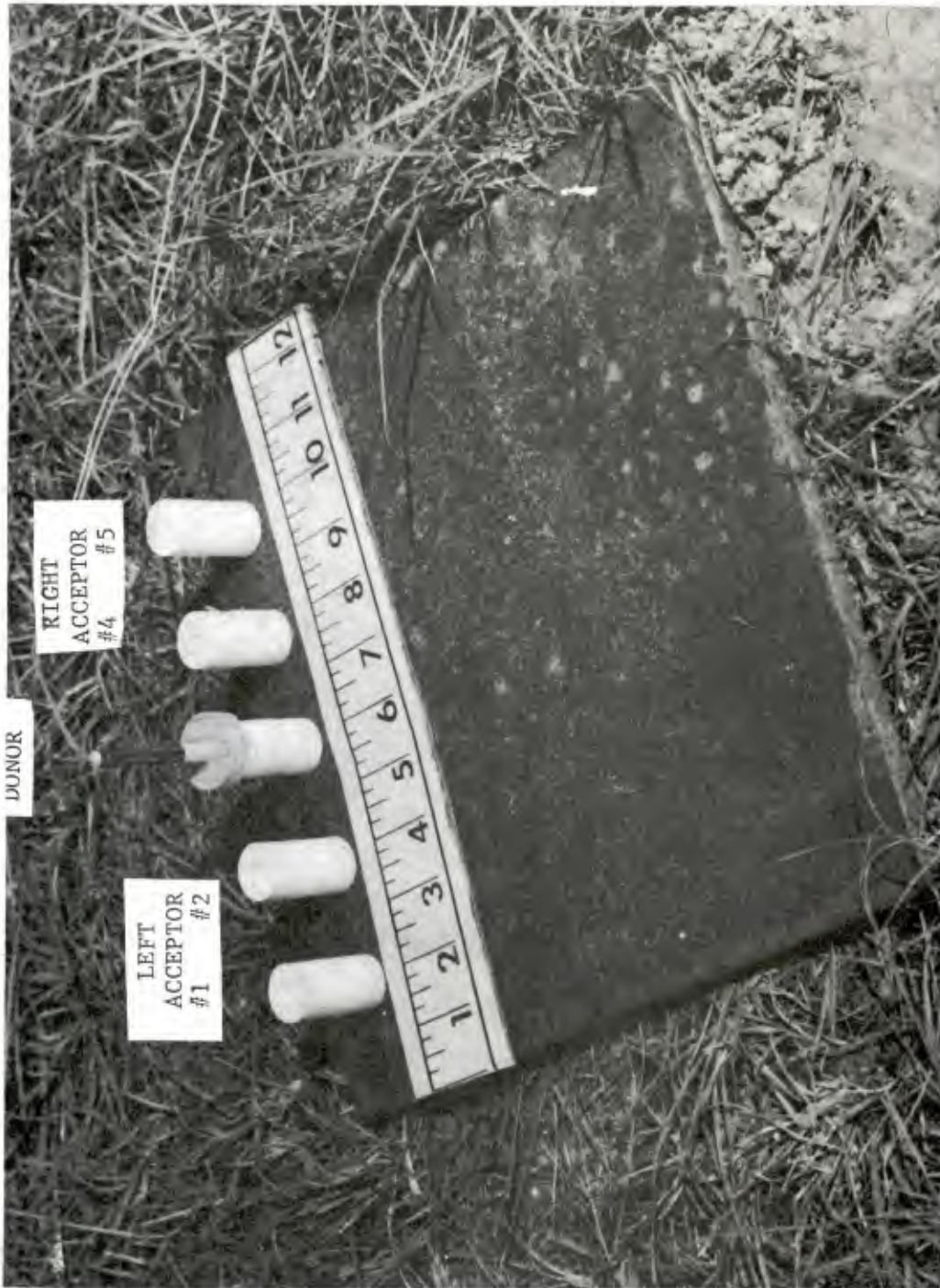

Figure 5. 30MM XM789 HEDP Projectile; test array for hardware configuration 1

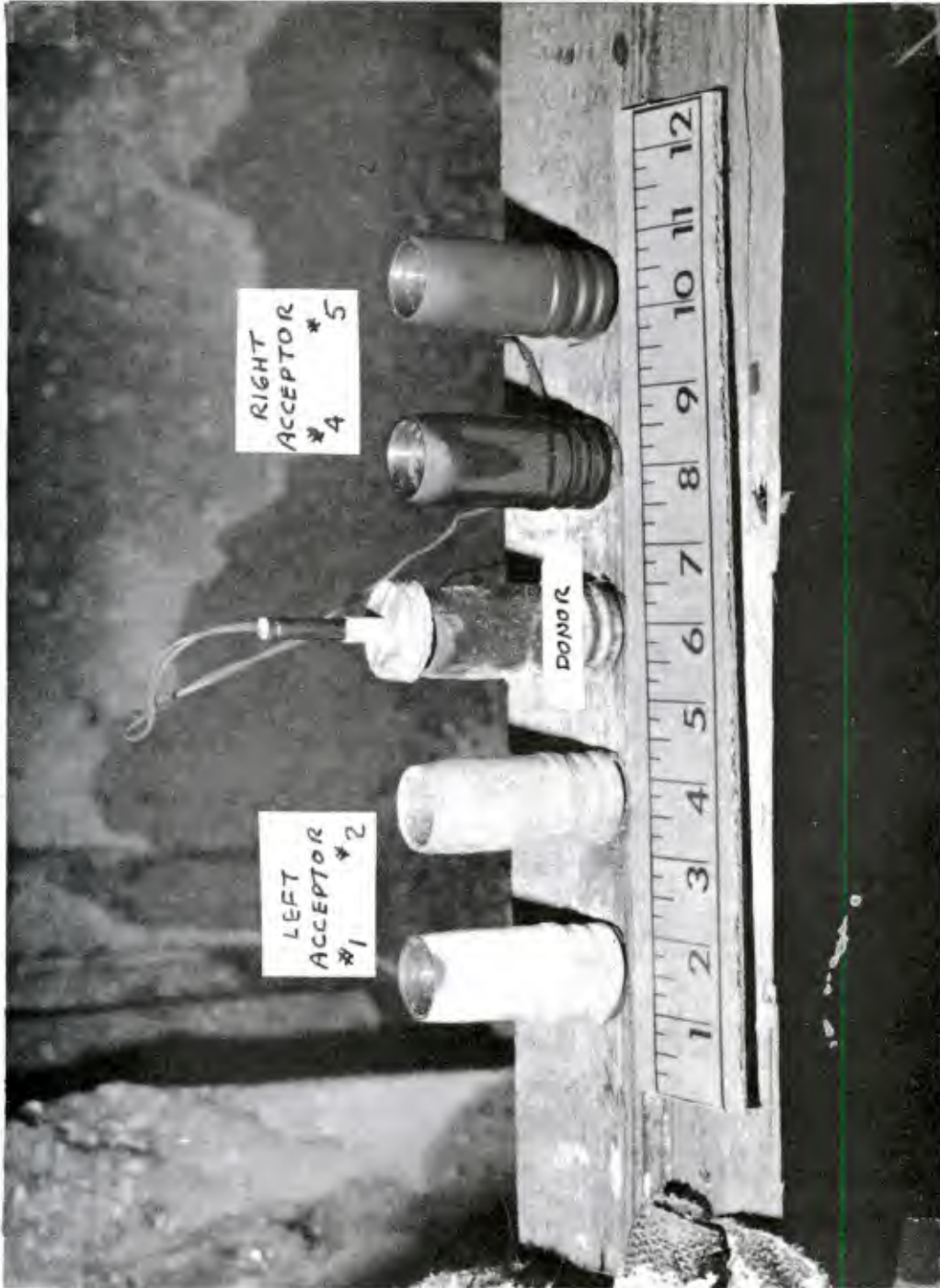

Figure 6. 30MM XM789 HEDP Projectile; test array for hardware configuration 2

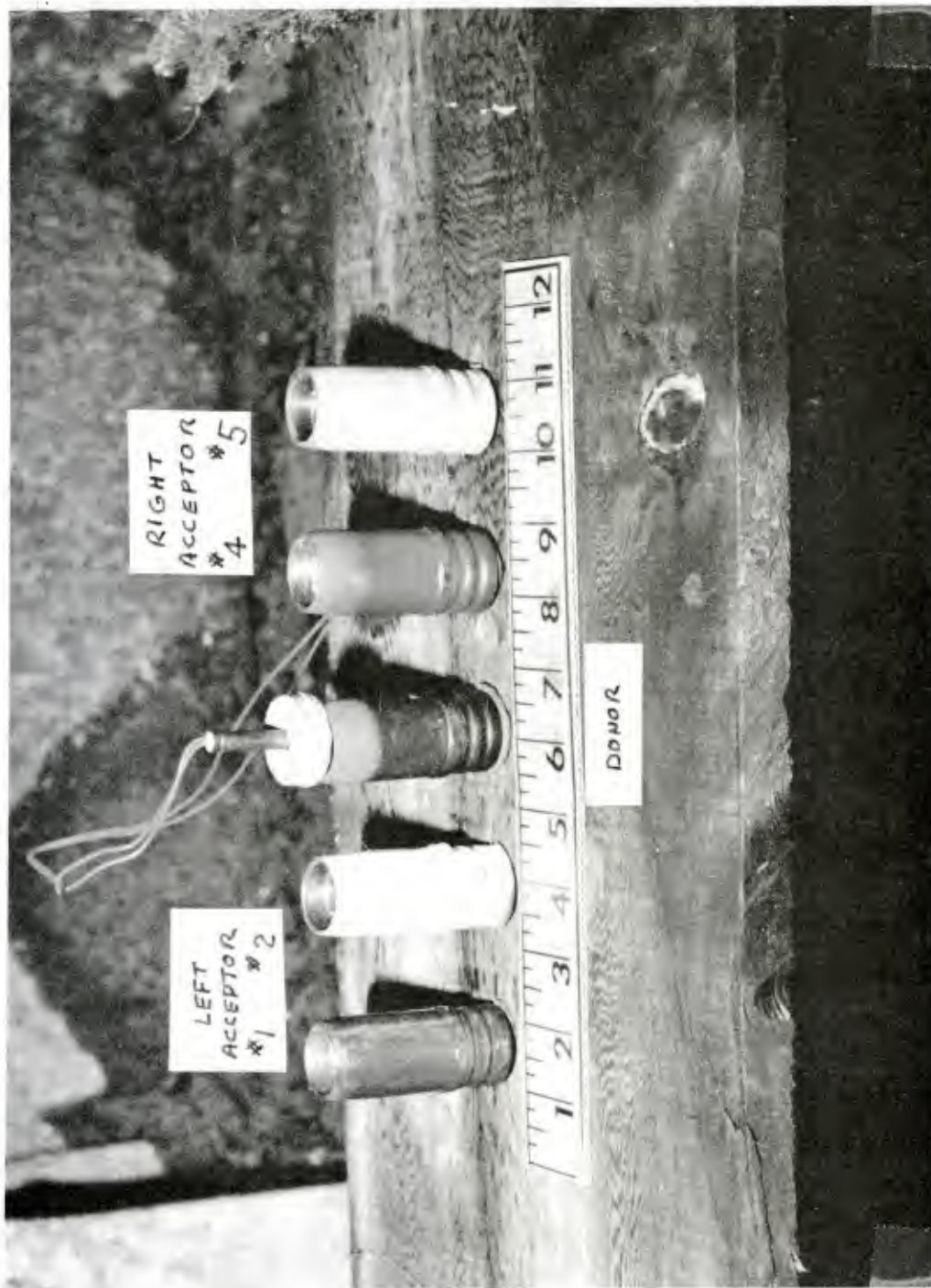

Figure 7. 30MM XM789 HEDP Projectile; test array for hardware configuration 3

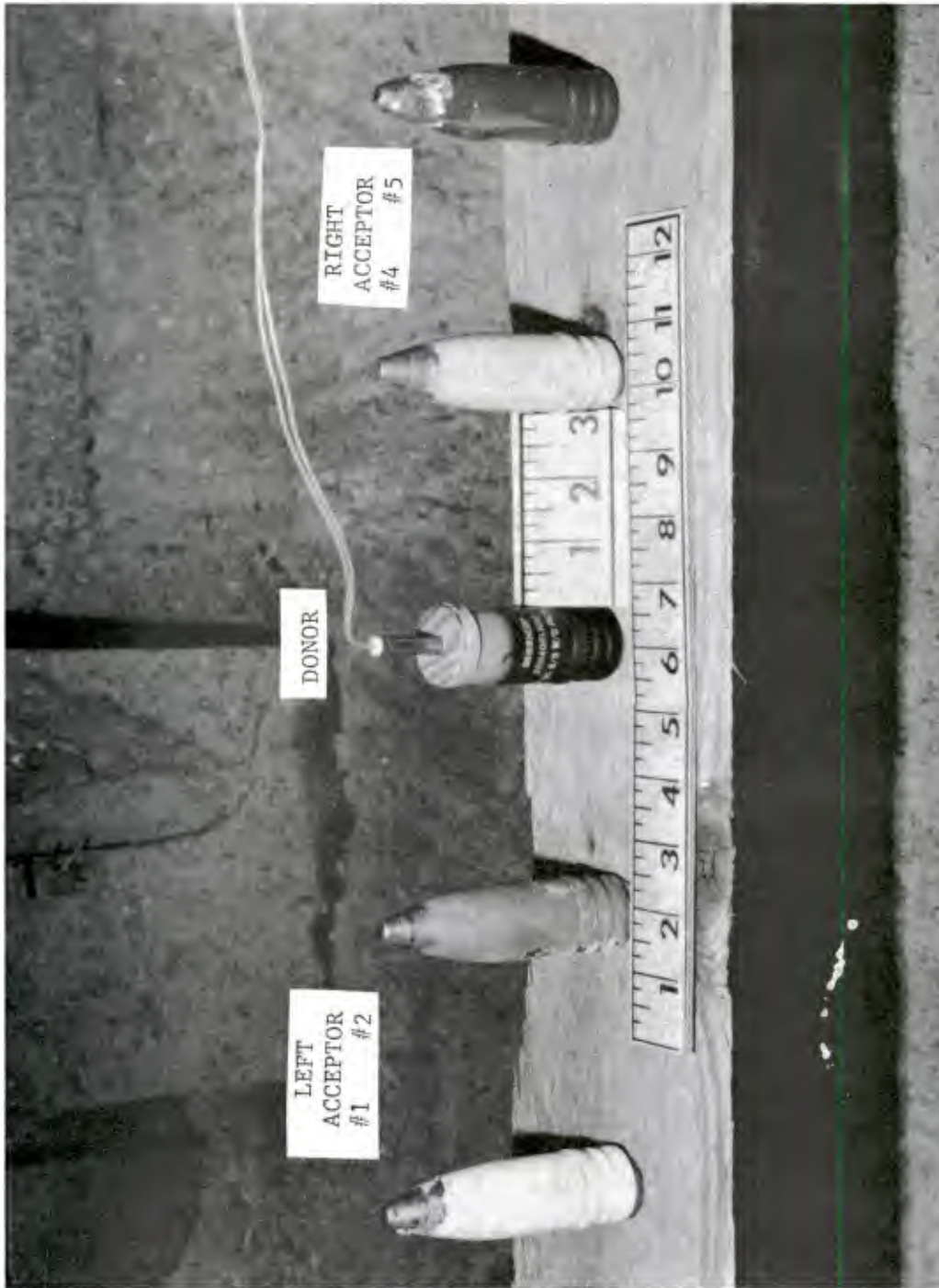

Figure 8. 30MM XM789 HEDP Projectile; test array for hardware configuration 5



Figure 9. Loaded body assembly at elevated temperature; pre-test configuration



Figure 10. Loaded body assembly at elevated temperature; pre-test oven configuration



Figure 11. Complete projectile at elevated cone temperature of 2050°F positioned and aligned horizontally; pre-test configuration



Figure 12. 30MM XM789 HEDP Projectile with J2 electric blasting cap

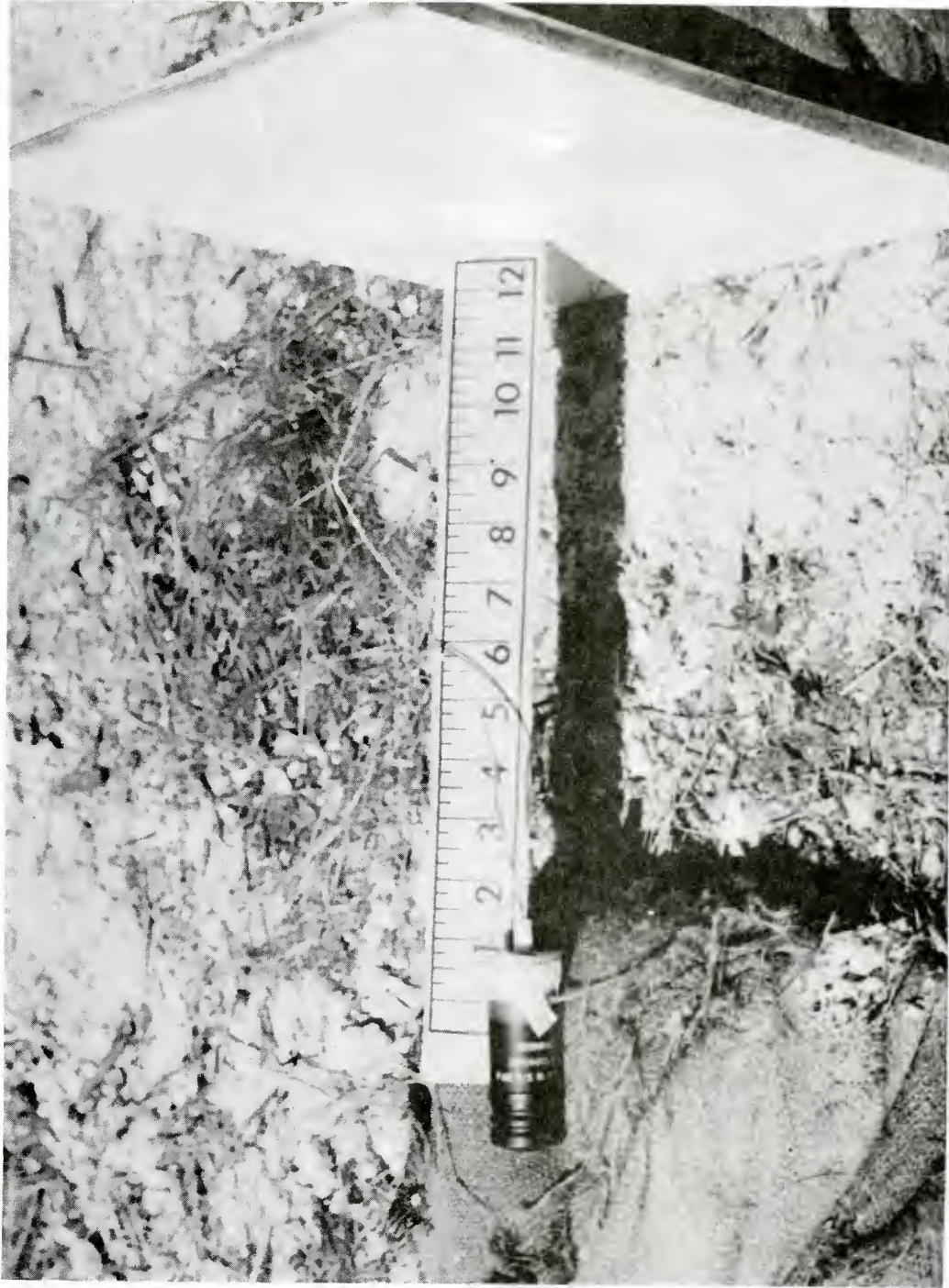

Figure 13. 30MM XM789 HEDP Projectile with M6 electric blasting cap



Figure 14. Bare PBXN5 pellets, 2 each; post-test results, non-propagation

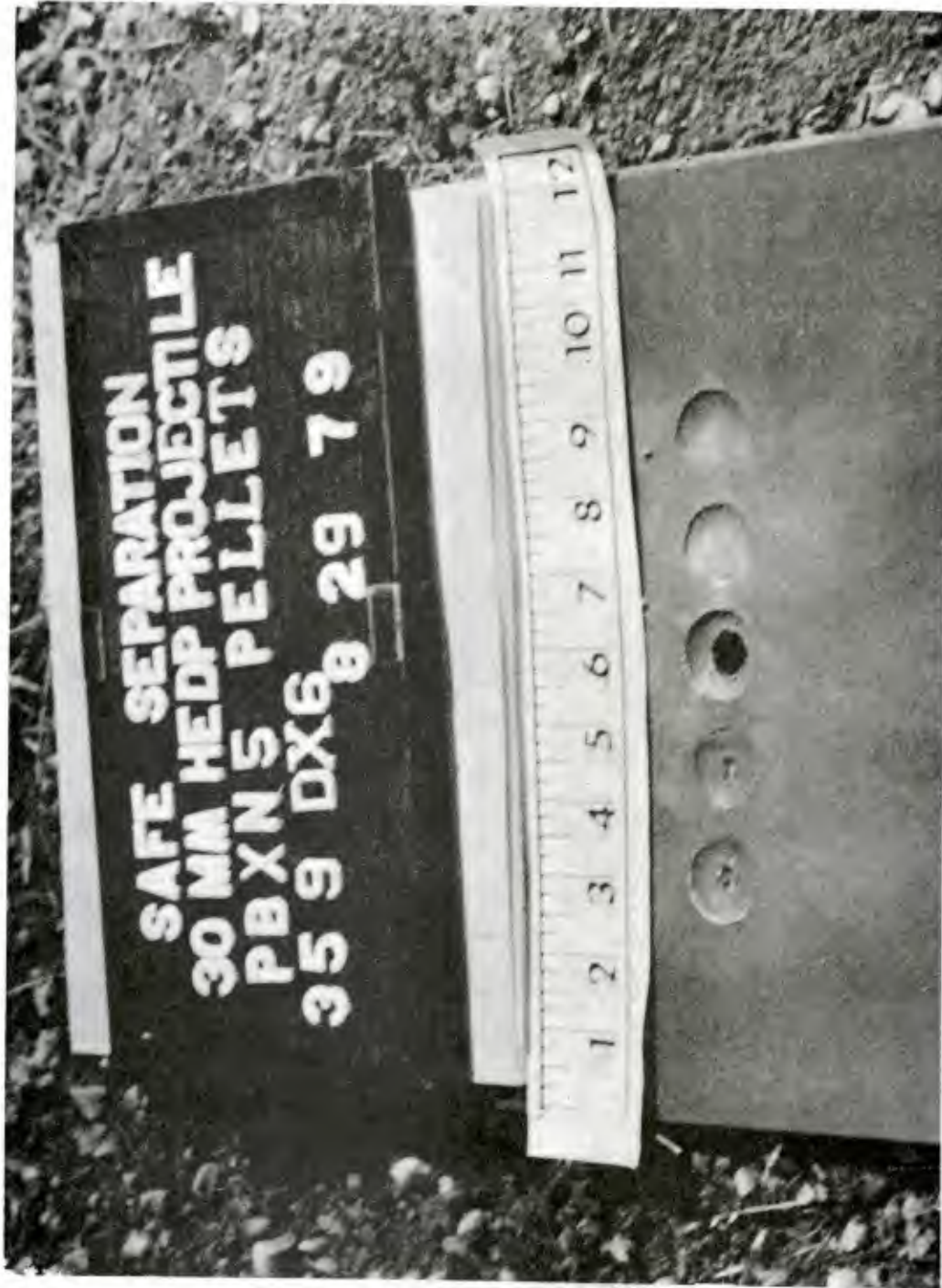

Figure 15. Bare PBXN5 pellets, 2 each; post-test results, propagation of all acceptors



Figure 16. Shell bodies with loose pellets; post-test results,  
low order propagation to inner acceptors



Figure 17. Loaded body assembly; post-test results,  
low order propagation to inner acceptors



Figure 18. Loaded body assembly at elevated cone temperature of 2050F; post-test results



Figure 19. Fuzed projectile; post-test results, complete non-propagation

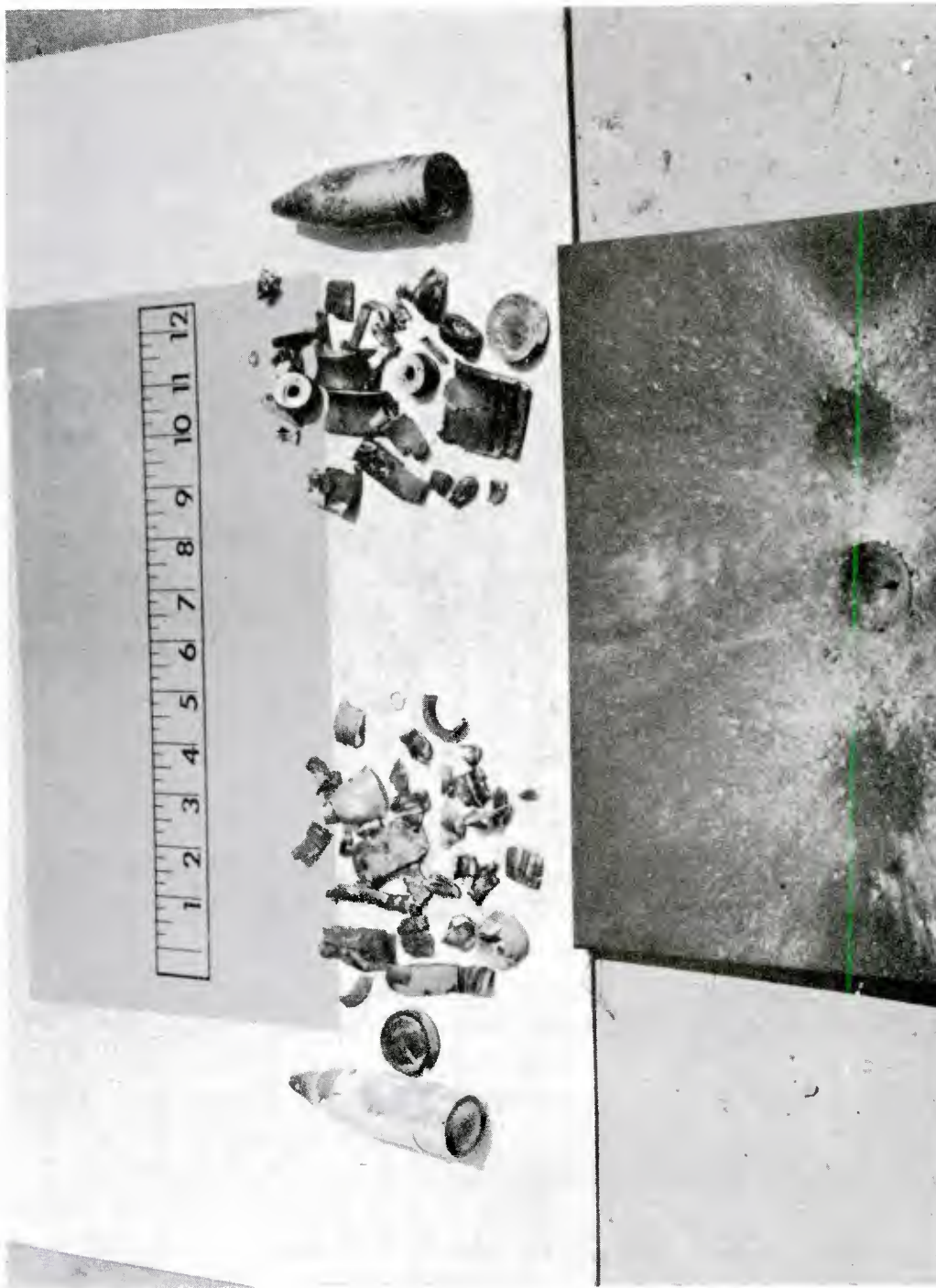

Figure 20. Fuzeed projectile; post-test results, propagation of inner acceptors



Figure 21. Complete projectile at elevated cone temperature of 205°F positioned and aligned horizontally; post-test destruction

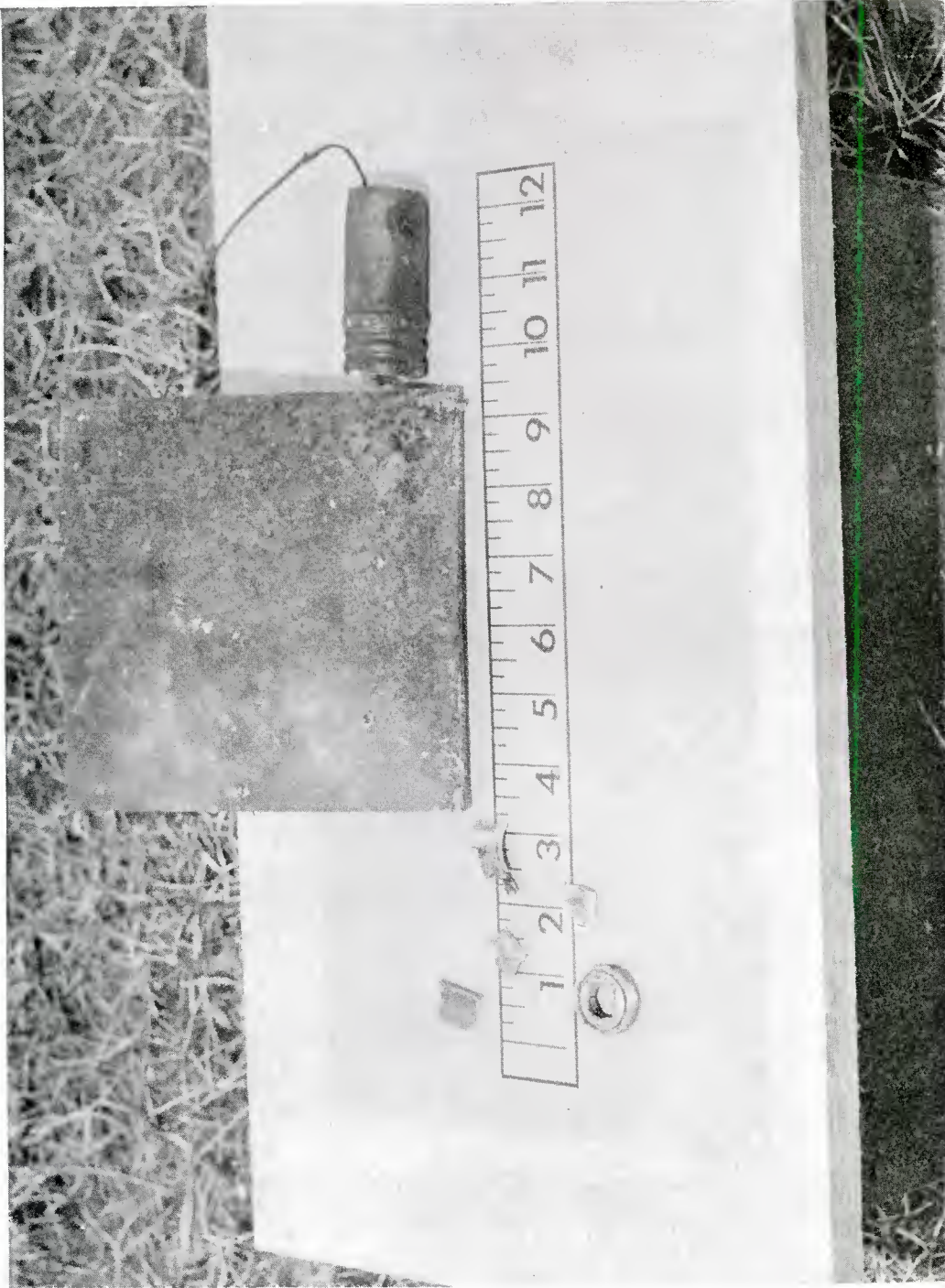

Figure 22. Complete projectile at elevated cone temperature of 2050°F positioned and aligned horizontally; post-test jet penetration

APPENDIX

STATISTICAL EVALUATION OF EXPLOSION PROPAGATION

## Statistical Theory

The possibility of the occurrence of explosion propagation based upon a statistical analysis of the test results has been evaluated in the main body of the report. This appendix is devoted to the mathematical means by which the statistical analysis was performed.

The probability of the occurrence of an explosion propagation is dependent upon the degree of certainty or confidence level involved and has upper and lower limits. The lower limit for all confidence levels is zero; whereas the upper limit is a function of the number of observations or, in this particular case, the number of acceptor items tested. Since each observation is independent of the others and each observation has a constant probability of a reaction occurrence (explosion propagation), the number of reactions (x) in a given number of observations (n) will have a binomial distribution. Therefore, the estimate of the probability (p) of a reaction occurrence can be represented mathematically by

$$p = x/n \quad (1)$$

and, therefore, the expected value of (x) is given by

$$E(x) = np \quad (2)$$

Each confidence level will have a specific upper limit ( $p_2$ ) depending upon the number of observations involved. The upper probability limit for a given confidence level  $\alpha$ , when a reaction is not observed, is expressed as

$$(1 - p_2)^n = \epsilon \quad (3)$$

where  $\epsilon = (1 - \alpha)/2$  and  $\alpha < 1.0$  (4)

Use of equation 3 is illustrated in the following example:

### Example

Determine the upper probability limit of the occurrence of an explosion propagation for a confidence level of 95% based upon 30 observations without a reaction occurrence.

### Given

Number of Observations (n) = 30  
Confidence Level ( $\alpha$ ) = 95%

### Solution

1. Substitute the given value of ( $\alpha$ ) into equation 4 and solve for  $\epsilon$ :

$$\epsilon = (1 - \alpha)/2 = (1 - 0.95)/2 = 0.025$$

2. Substitute the given value of (n) and value of ( $\alpha$ ) into equation 3 and solve for  $p_2$ :

$$\epsilon = 0.025 = (1 - p_2)^{30}$$

or

$$p_2 = 0.116(11.6\%)$$

### Conclusions

For a 95% confidence level and 30 observations, the true value of the probability of explosion propagation will fall between zero and 0.116; or statistically, it can be interpreted that in 30 observations, a maximum of  $(0.116 \times 30) = 3.48$  observations could result in a reaction for a 95% confidence level.

### Probability Table

Table A-1 shows the probability limits and the range of the expected value  $E(x)$  for different numbers of observations. Three confidence limits, 90, 95 and 99%, are used to derive the probabilities. The same values are plotted in Figure A-1.

Table A-1. Probabilities of propagation for various confidence limits

Number of observations	90%		95%		99%	
	P2	<u>C.L.</u> E(x)	P2	<u>C.L.</u> E(x)	P2	<u>C.L.</u> E(x)
10	0.259	2.59	0.308	3.08	0.411	4.11
20	0.131	2.62	0.168	3.36	0.233	4.66
30	0.095	2.85	0.116	3.48	0.162	4.86
40	0.072	2.88	0.088	3.52	0.124	4.96
50	0.058	2.9	0.071	3.55	0.101	5.05
60	0.049	2.92	0.060	3.6	0.085	5.10
80	0.037	2.96	0.045	3.6	0.064	5.12
100	0.030	3.0	0.036	3.6	0.052	5.2
200	0.015	3.0	0.018	3.6	0.026	5.2
300	0.010	3.0	0.012	3.6	0.018	5.4
500	0.006	3.0	0.007	3.5	0.011	5.5

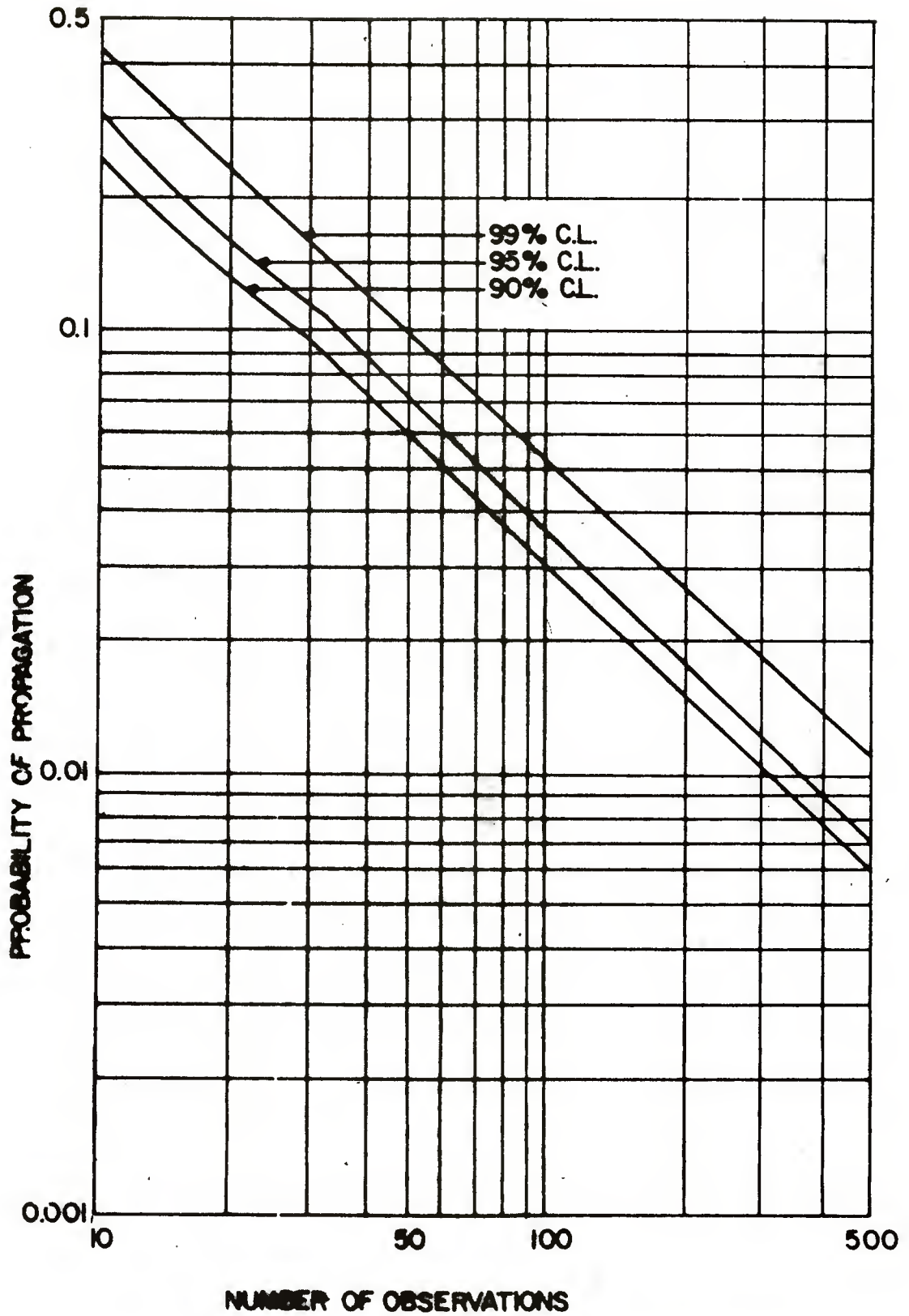

**FIGURE A-1. Variations of propagation probability vs. number of observations as a function of confidence level.**

DISTRIBUTION LIST

Commander  
U.S. Army Armament Research and  
Development Command

ATTN: DRDAR-CG  
DRDAR-LC  
DRDAR-LCM  
DRDAR-LCM-S<sup>f</sup> (12)  
DRDAR-SF (12)  
DRDAR-TSS (5)  
DRDAR-LCU-P  
DRDAR-GCL

Dover, NJ 07801

Commander  
U.S. Army Materiel Development and  
Readiness Command

ATTN: DRCDE  
DRCIS-E  
DRCPA-E  
DRCPP-I  
DRCDL  
DRCSG-S

5001 Eisenhower Avenue  
Alexandria, VA 22333

Commander  
USDRC Installations & Service Agency

ATTN: DRCIS-RI-IU  
DRCIS-RI-IC

Rock Island, IL 61299

Commander  
U.S. Army Armament Materiel  
Readiness Command

ATTN: DRSAR-IR (2)  
DRSAR-IRC  
DRSAR-ISE (2)  
DRSAR-IRC-E  
DRSAR-PDM  
DRSAR-LC (2)  
DRSAR-ASF (2)  
DRSAR-SF (3)  
DRSAR-LEP-L

Rock Island, IL 61299

Chairman  
Department of Defense Explosives  
Safety Board (2)  
Hoffman Building 1, Room 856C  
2461 Eisenhower Avenue  
Alexandria, VA 22331

Project Manager for Munitions Production  
Base Modernization and Expansion  
ATTN: DRCPLM-PBM-LA  
DRCPM-PBM-T-SF  
DRCPM-PBM-EP (2)  
Dover, NJ 07801

Director  
Ballistic Research Laboratory  
U.S. Army Armament Research and  
Development Command  
ATTN: DRDAR-BLE, (C. Kingery) (2)  
DRDAR-TSB-S  
Aberdeen Proving Ground, MD 21010

Administrator  
Defense Technical Information Center  
ATTN: Accessions Division (12)  
Cameron Station  
Alexandria, VA 22314

Commander  
U.S. Army Construction Engineering  
Research Laboratory  
ATTN: CERL-ER  
Champaign, IL 61820

Office, Chief of Engineers  
ATTN: DAEN-MZA-E  
Washington, D.C. 20314

U.S. Army Engineer District, Huntsville  
ATTN: Construction Division-HAD-ED (2)  
P.O. Box 1600, West Station  
Huntsville, AL 35807

Director  
U.S. Army Industrial Base  
Engineering Activity  
ATTN: DRXIB-MT (2)  
Rock Island, IL 61299

Director  
DARCOM Field Safety Activity  
ATTN: DRXOS (5)  
Charlestown, IN 47111 .

Commander  
Crane Army Ammunition Plant  
ATTN: SARCN  
Crane, IN 47522

Commander  
Hawthorne Army Ammunition Plant  
ATTN: SARHW-SF  
Hawthorne, NV 89415

Commander  
Holston Army Ammunition Plant  
ATTN: SARHO-E  
Kingsport, TN 37662

Commander  
Indiana Army Ammunition Plant  
ATTN: SARIN-OR (2)  
SARIN-SF  
Charlestown, IN 47111

Commander  
Iowa Army Ammunition Plant  
ATTN: SARIO-S  
Middletown, IA 52638

Commander  
Kansas Army Ammunition Plant  
ATTN: SARKA-CE  
Parsons, KN 67537

Commander  
Lone Star Army Ammunition Plant  
ATTN: SARLS-IE  
Texarkana, TX 57701

Commander  
Longhorn Army Ammunition Plant  
ATTN: SARLO-S  
Marshall, TX 75607

Commander  
McAlester Army Ammunition Plant  
ATTN: SARVC-SF  
McAlester, OK 74501

Commander  
Milan Army Ammunition Plant  
ATTN: SARMI-S  
Milan, TN 38358

Commander  
Radford Army Ammunition Plant  
ATTN: SARRA-IE  
Radford, VA 24141

Commander  
Sunflower Army Ammunition Plant  
ATTN: SARSU-S  
Lawrence, KA 66044

Commander  
Volunteer Army Ammunition Plant  
ATTN: SARVO-S  
Chattanooga, TN 37401

Commander  
Pine Bluff Arsenal  
ATTN: SARPB-SA  
Pine Bluff, AR 71601

Commander  
Rocky Mountain Arsenal  
ATTN: SARRM-SAF  
Denver, CO 80240

Director  
U.S. Army Materiel Systems  
Analysis Activity  
ATTN: DRXSY-MP  
Aberdeen Proving Ground, MD 21005

Commander/Director  
Chemical Systems Laboratory  
U.S. Army Armament Research and  
Development Command  
ATTN: DRDAR-CLB-PA, M. Miller  
DRDAR-CLJ-L  
APG, Edgewood Area, MD 21010

Chief  
Benet Weapons Laboratory, LCL  
U.S. Army Armament Research and  
Development Command  
ATTN: DRDAR-LCB-TL  
Watervliet, NY 12189

Commander  
Badger Army Ammunition Plant  
ATTN: SARBA  
Baraboo, WI 53913