

MICROCOPY RESOLUTION TEST CHART
NATIONAL BUREAU OF STANDARDS-1963-A

①

Technical Report E6357-14
Contract N00039-76-C-0141

IITRI

ELECTRIC AND MAGNETIC FIELD MEASUREMENTS AT THE
WISCONSIN TEST FACILITY IN SUPPORT OF THE SOIL
ARTHROPOD AND OXYGEN CONSUMPTION STUDIES DURING
1972-1977

J. R. Gauger

April 1978

Prepared for

U. S. Naval Electronic Systems Command
Washington, D. C.

Submitted by

IIT Research Institute
10 West 35th Street
Chicago, Illinois 60616

DTIC
ELECTE
S FEB 10 1983 D
E

This document has been approved
for public release and sale; its
distribution is unlimited.

ADA 124309

DTIC FILE COPY

88 02 010 098

FOREWORD

This report documents the extremely low frequency (ELF) electromagnetic field measurements made at selected biological test and control plots in the Chequamegon National Forest near to and remote from the U. S. Navy's Wisconsin Test Facility (WTF). The study was performed at the direction of the Naval Electronic Systems Command. The work began under Contract No. N00039-73-C-0030 and is continuing under Contract No. N00039-76-C-0141. The measurements were made by personnel of the IIT Research Institute (IITRI) during 1972 through 1977, in support of soil arthropod and oxygen consumption studies performed by Dr. Bernard Greenberg of the University of Illinois at Chicago Circle, Chicago, Illinois.

Respectfully submitted,

IIT RESEARCH INSTITUTE

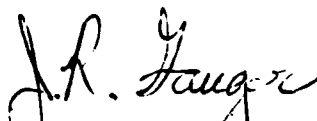

J. R. Gauger
Associate Engineer

APPROVED



R. D. Carlson
Program Manager



A. R. Valentino
Manager, EM Effects

Accession For	
NTIS GRA&I	<input checked="" type="checkbox"/>
DTIC TAB	<input type="checkbox"/>
Unannounced	<input type="checkbox"/>
Justification	
By _____	
Distribution/	
Availability Codes	
Dist	Avail and/or Special
A	

IIT RESEARCH INSTITUTE



TABLE OF CONTENTS

	<u>Page</u>
FOREWORD	ii
1. INTRODUCTION	1
2. TEST EQUIPMENT AND MEASUREMENT TECHNIQUES	2
3. MAGNETIC FIELD MEASUREMENTS	5
4. ELECTRIC FIELD MEASUREMENTS	8
4.1 Low Impedance Electric Field	9
4.2 High Impedance Electric Field	12
REFERENCES	15
APPENDIX A--Soil Arthropod and Oxygen Consumption Test and Control Sites in the Area Surrounding the Wisconsin Test Facility.	17
APPENDIX B--Summary of Operation of the Wisconsin Test Facility for the Period June 1971 to June 1977	38

LIST OF FIGURES AND TABLES

<u>Figure</u>		<u>Page</u>
1	Low Impedance Electric Field Measurements	3
A-1	Location of the Oxygen Consumption and Soil Arthropod Test and Control Sites and the ELF Antenna in the Chequamegon National Forest, Wisconsin	19
A-2	Site #1--Clover Control and Site #2--North Leg Control . . .	23
A-3	Hardwood Control Site #3	24
A-4	Site #4--South Roadside Control and Site #5--Salamander Control	25
A-5	Site #6--Main Control 1,2,3 and Site #28--B15 Control	26
A-6	Sites #8 - #12	27
A-7	Site #13--Hardwood Test and Site #16--GG Test	28
A-8	Site #7--North Leg Test, Site #15--New Clover Test, and Site #14--Ant Test	29
A-9	Site #17--Main Test and #18--Old Clover Test	30
A-10	Hazelton Test Sites #19 and #20	31
A-11	Site #21--Hazelton Control and Site #25--M Yard Control . . .	32
A-12	Site #22--Ant Control	33
A-13	Site #23--Dam Control and Site #24--N Yard Control	34
A-14	Site #26--60 Hz Test, Site #27--Dam Dump Control	35
A-15	Site #29--A15 Test and Site #30--A16 Test	36
A-16	Site #31--A17 Test	37
 <u>Table</u>		
1	Magnetic Fields at Test and Control Plots (Oxygen Consumption)	6
2	Magnetic Fields at Test and Control Plots (Soil Arthropod) .	7
3	Low Impedance Electric Fields at the Test and Control Plots (Oxygen Consumption)	10

LIST OF FIGURES AND TABLES (Cont.)

<u>Table</u>		<u>Page</u>
4	Low Impedance Electric Fields at Test and Control Plots (Soil Arthropod)	11
5	High Impedance Electric Fields Measured at Test and Control Plots (Oxygen Consumption) Antennas at 300 Amperes	13
6	High Impedance Electric Fields at Test and Control Plots (Soil Arthropods)	14
B-1	WTF Operation for June 1971 to June 1972	40
B-2	WTF Operation for June 1972 to June 1973	41
B-3	WTF Operation for June 1973 to June 1974	42
B-4	WTF Operation for June 1974 to June 1975	43
B-5	WTF Operation for June 1975 to June 1976	44
B-6	WTF Operation for June 1976 to June 1977	45

1. INTRODUCTION

→ During the summers of 1972-1977, extremely low frequency (ELF) electric and magnetic fields have been measured at selected biological test and control plots in the Chequamegon National Forest in northern Wisconsin. The test plots are near to, and control plots are remote from the ELF antenna of the Naval Electronic Systems Command's Sanguine/Seafarer Wisconsin Test Facility (WTF). The measurements have been made in support of soil arthropod and oxygen consumption studies performed by Dr. B. Greenberg of the University of Illinois at Chicago Circle in an effort to determine possible biological effects of an ELF communications system.*

→ Each summer, the magnetic field and the low impedance electric field (the field in the earth) were measured at each site. In addition, in 1975 the high impedance electric field (the field in air) was also measured, due to increasing interest in this type of field. In 1976 and 1977 the high impedance electric field was not measured. This was due to malfunction of the high impedance electric field probe in 1976, and time limitations imposed by other field work requirements and the operating schedule of the WTF in 1977. The lack of these measurements does not degrade the validity of the studies, as the high impedance electric field is due to the voltage of an overhead antenna with respect to ground and will not be generated by a buried ELF antenna system. Further, the high impedance field is not present in the ground. ←

Appendix A gives a detailed description of how to locate each test and control plot along with an individual map of each plot. An overview map of the WTF area is also provided to show the relative location of the sites and the ELF antenna. Appendix B provides a breakdown of the modes of operation of the WTF antenna over the period June 1971 to June 1977.

* Dr. Greenberg's biological research is described in References 1-15.

2. TEST EQUIPMENT AND MEASUREMENT TECHNIQUES

The magnetic field was measured using a single axis magnetic field probe designed and built by IITRI. This probe is a many turned coil with a ferrite core and terminating resistor. Appropriate conversion factors were used to convert the voltage reading at the output of the probe to an equivalent magnetic flux density.

The low impedance electric field (i.e., the horizontal electric field at the earth's surface) was measured with one-meter probe wires. Figure 1 shows the equipment configuration used for the low impedance electric field probe wire measurements.

The sensor used for measuring the high impedance electric field (i.e., the field in air) was the IITRI constructed ELF electric field probe.¹⁶ The probe consists of two insulated hemispheres which form a split sphere 6 cm in diameter. The probe senses the electric field on its axis and transmits a modulated light replica of the electric field to the receiver via a six-foot fiber optic cable. At the far end of the cable, the specially designed receiver changes the light signal back to an electric signal which is proportional to the field sensed by the transmitter. The output of the receiver is measured with a frequency selective voltmeter and converted by means of appropriate conversion factors to an electric field intensity.

In the years preceding 1977, all measurements were made with the WTF transmitting single frequency, sinusoid signals at 45 Hz and 75 Hz. Measurements were made for each frequency and for each leg of the antenna transmitting separately. These conditions reflected the primary operating modes of the WTF up to that time. On 20 August 1976, however, the WTF commenced twenty-four hour operation with both antennas transmitting a minimum shift keying (MSK) signal with a center frequency of 76 Hz and a modulation rate of 16 Hz. MSK is a special type of frequency modulation (FM). The electromagnetic field measurements in 1977, therefore, were made with the WTF operating in this condition.

Each of the three field probes is sensitive on a single axis. Therefore, accurate and repeatable methodologies for measuring the field magnitudes were needed. Two cases were apparent: (1) the mode of a single frequency being

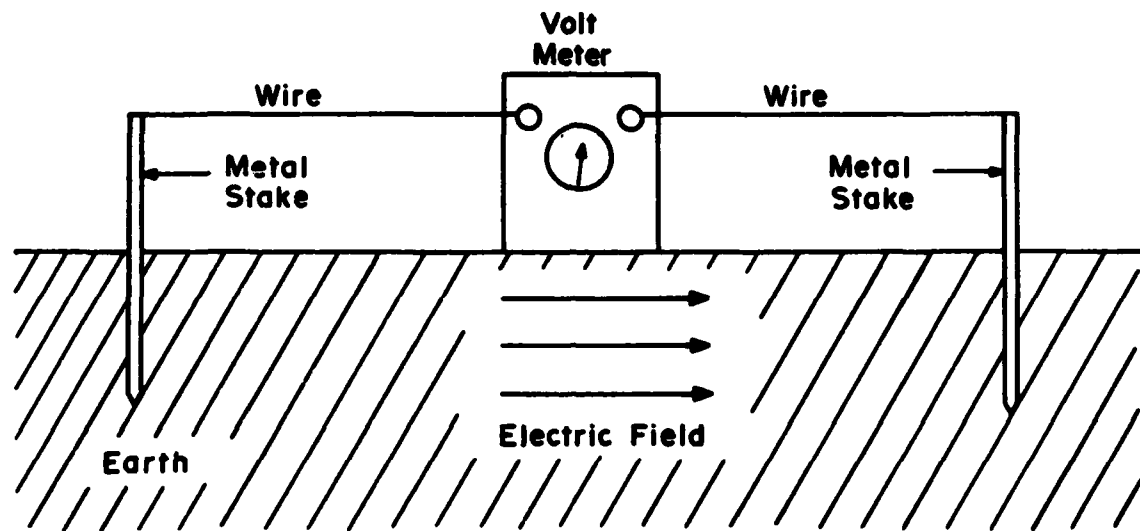

a) Measuring A Horizontal Electric Field In The Earth

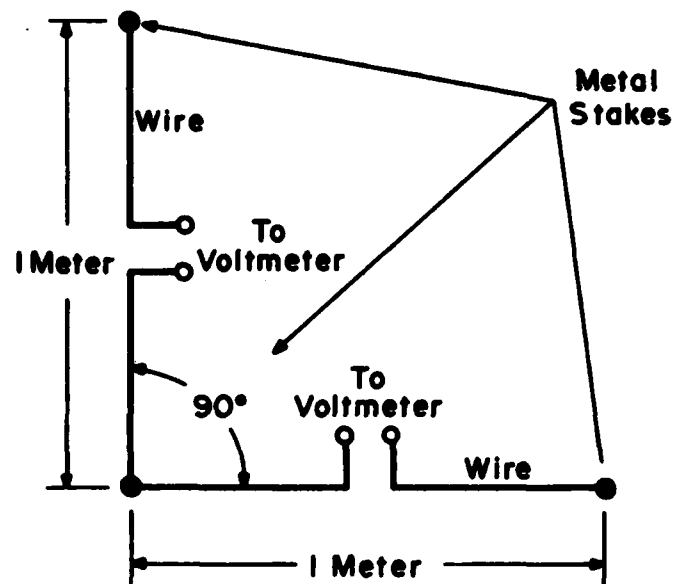

b) Geometry For Perpendicular Probe Wires

Fig. 1 LOW IMPEDANCE ELECTRIC FIELD MEASUREMENTS

transmitted by a single antenna and (2) the mode of both antennas transmitting the same MSK signal at some relative phase.

When the WTF transmits single frequency/single antenna, the electric and magnetic fields generated at any point may be thought of as a simple vector having unique magnitude and direction. It should be noted that in this case the field magnitude in a direction perpendicular to the direction of the field vector is zero. Therefore, the method used to determine the magnitude of the fields in 1972 to 1976 was as follows:

- a) Three orthogonal components of each field were measured; i.e., the north-south, east-west, and vertical components (only the north-south and east-west components of the low impedance electric field were measured as this field has no vertical component at the earth's surface).
- b) The magnitude of each field was then computed as the root of the sum of the squares of its orthogonal components.

When the two antenna elements are operated simultaneously, the electric and magnetic fields generated are more complex. The two sources contribute components to the total fields which, in general, are out of phase. The fields cannot be described by a single measurement unless one of the sources dominates, as is the case for many of the measurements made. Therefore, the method used in 1977 was to record the maximum and minimum fields at each location.

The meters employed to measure the output voltages of the probes described here were the specially constructed tuned voltmeters (TVM's) which were supplied by the Navy for ELF measurements, the commercially available Hewlett-Packard 302A wave analyzer, and the commercially available Hewlett-Packard 3581A signal wave analyzer. All three instruments function as battery operated, frequency selective voltmeters. The TVM's and HP302A were used from 1972 through 1975, and the HP3581A was used in 1976 and 1977. The HP3581A is a newly available instrument, and was factory modified for a 1 Hz bandwidth and battery operation. It was used to replace the increasingly unreliable TVM's and the bulky HP302A. The HP3581A was used in its 30 Hz bandwidth mode to measure the MSK signal. A multi-frequency battery operated notch filter, which was designed and fabricated by IITRI, was used in conjunction with the HP3581A to eliminate power line interference at 60 Hz and the harmonics thereof when taking MSK measurements.

3. MAGNETIC FIELD MEASUREMENTS

Tables 1 and 2 give the measured magnetic flux densities at the oxygen consumption sites and the soil arthropod sites, respectively, for measurements taken during the period 1972-1977. The values of the measured magnetic field show a certain degree of fluctuation from year to year. The reason for this is that the only locations where the field exceeds the 0.001 gauss level are physically near an antenna. At these locations, positioning of the probe is very important. Near the antenna, the magnetic fields may be expected to vary as the inverse of the distance from the test point to the antenna. As a result of this behavior, the highest values of magnetic field occur closest to the antenna; but at these locations, the positioning is also most critical. This fact is borne out by measurement. The higher magnetic flux densities show a larger degree of change than the lower magnetic flux densities. This is due to the fact that it was difficult to obtain exactly the same measurement locations and positioning of the probe year after year.

The maximum 1977 field values, although measured with both antennas transmitting a MSK signal are quite similar to maximum field levels obtained in previous years with single antenna, single frequency measurements. This is not an unexpected result, as most of the sites are situated near only one antenna, and hence this antenna will contribute most of the field component at the site. The 1977 minimum field values were generally less than 0.001 gauss.

TABLE 1
MAGNETIC FIELDS AT TEST AND CONTROL PLOTS (OXYGEN CONSUMPTION)

SITE	MAGNETIC FLUX DENSITY (GAUSS)																									
	E/W ANTENNA								W/S ANTENNA								76 HZ HSK*									
	60 HZ				75 HZ				80 HZ				75 HZ				76 HZ				60 HZ					
	1972	1973	1974	1975	1976	1977	1978	1979	1980	1981	1982	1983	1984	1985	1986	1987	1988	1989	1990	1991	1992	1993	1994	1995	1996	1997
SALAMONSON/ MEMORIAL TEST	A	A	A	B	B	B	B	B	B	B	B	B	B	B	B	B	B	B	B	B	B	B	B	B	B	B
SALAMONSON/ CONTROL	B	A	B	B	B	B	B	B	B	B	B	B	B	B	B	B	B	B	B	B	B	B	B	B	B	B
ANT TEST	A	A	A	B	C	A	A	A	B	B	C	A	A	B	C	A	A	A	A	A	A	A	A	A	A	A
ANT CONTROL	A	A	A	B	C	A	A	A	B	C	A	A	A	B	C	A	A	A	A	A	A	A	A	A	A	A
SOUTH BRADSHIRE TEST	B	B	B	B	B	B	B	B	B	B	B	B	B	B	B	B	B	B	B	B	B	B	B	B	B	B
EASTWOOD/ TEMPO TEST	A	A	A	B	B	B	B	B	B	B	B	B	B	B	B	B	B	B	B	B	B	B	B	B	B	B
S YARD CONTROL	B	A	B	B	B	B	B	B	B	B	B	B	B	B	B	B	B	B	B	B	B	B	B	B	B	B
BAR CONTROL	B	A	A	B	B	B	B	B	B	B	B	B	B	B	B	B	B	B	B	B	B	B	B	B	B	B
N YARD CONTROL	B	A	A	B	B	B	B	B	B	B	B	B	B	B	B	B	B	B	B	B	B	B	B	B	B	B
BAR SHIP	A	A	A	A	A	A	A	A	A	A	A	A	A	A	A	A	A	A	A	A	A	A	A	A	A	A

*60 HZ ANTENNAS TRANSMITTING A 740HZ, 100V SIGNAL AT 300A AND 251° PHASING
KEY: A = NO NEARBY OBJECTS, B = < 0.001 GAUSS, C = SITE ADJACENT

TABLE 2
MAGNETIC FIELDS AT TEST AND CONTROL PLOTS (SOIL ARTHROPOD)

SITE	MAGNETIC FLUX DENSITY (GAUSS)																													
	E/W ANTENNA												N/S ANTENNA												76 HZ HSK*		AMBIENT LEVELS			
	45 HZ				75 HZ				45 HZ				75 HZ				75 HZ				1977		60 HZ							
	1972	1973	1975	1976	1972	1973	1975	1976	1972	1973	1975	1976	1972	1973	1975	1976	1972	1973	1975	1976	MAX	MIN	1972	1973	1975	1976	1977			
MAIN TEST (A1A)	0.049	0.000	0.060	0.007	0.061	0.090	0.074	0.000	0.000	0.000	0.000	0.000	0.000	0.000	0.000	0.000	0.000	0.000	0.000	0.000	0.067	0.027	0.000	0.000	0.000	0.000	0.000			
MAIN TEST (A1B)	0.056	0.055	0.028	0.040	0.052	0.044	0.058	0.051	0.051	0.051	0.051	0.051	0.051	0.051	0.051	0.051	0.051	0.051	0.051	0.051	0.027	0.027	0.000	0.000	0.000	0.000	0.000			
MAIN TEST (A1C)	0.045	0.040	0.040	0.051	0.041	0.042	0.046	0.085	0.085	0.085	0.085	0.085	0.085	0.085	0.085	0.085	0.085	0.085	0.085	0.085	0.045	0.045	0.000	0.000	0.000	0.000	0.000			
MAIN CONTROL (B1A)	0.000	0.000	0.000	0.000	0.000	0.000	0.000	0.000	0.000	0.000	0.000	0.000	0.000	0.000	0.000	0.000	0.000	0.000	0.000	0.000	0.000	0.000	0.000	0.000	0.000	0.000	0.000			
MAIN CONTROL (B1B)	0.000	0.000	0.000	0.000	0.000	0.000	0.000	0.000	0.000	0.000	0.000	0.000	0.000	0.000	0.000	0.000	0.000	0.000	0.000	0.000	0.000	0.000	0.000	0.000	0.000	0.000	0.000			
MAIN CONTROL (B1C)	0.000	0.000	0.000	0.000	0.000	0.000	0.000	0.000	0.000	0.000	0.000	0.000	0.000	0.000	0.000	0.000	0.000	0.000	0.000	0.000	0.000	0.000	0.000	0.000	0.000	0.000	0.000			
OLD CLOVER TEST (A2)	0.061	0.302	0.060	0.007	0.064	0.076	0.067	0.072	0.072	0.072	0.072	0.072	0.072	0.072	0.072	0.072	0.072	0.072	0.072	0.072	0.060	0.060	0.000	0.000	0.000	0.000	0.000			
NEW CLOVER TEST (A10)	0.000	0.000	0.000	0.000	0.000	0.000	0.000	0.000	0.000	0.000	0.000	0.000	0.000	0.000	0.000	0.000	0.000	0.000	0.000	0.000	0.075	0.075	0.000	0.000	0.000	0.000	0.000			
CLOVER CONTROL (B2)	0.000	0.000	0.000	0.000	0.000	0.000	0.000	0.000	0.000	0.000	0.000	0.000	0.000	0.000	0.000	0.000	0.000	0.000	0.000	0.000	0.000	0.000	0.000	0.000	0.000	0.000	0.000			
GG TEST (A12)	0.80	0.84	0.599	0.277	0.75	0.68	0.592	0.300	0.300	0.300	0.300	0.300	0.300	0.300	0.300	0.300	0.300	0.300	0.300	0.300	0.18	0.18	0.000	0.000	0.000	0.000	0.000			
NORTH LEG TEST (A17)	0.000	0.000	0.000	0.000	0.000	0.000	0.000	0.000	0.000	0.000	0.000	0.000	0.000	0.000	0.000	0.000	0.000	0.000	0.000	0.000	0.029	0.029	0.000	0.000	0.000	0.000	0.000			
NORTH LEG CONTROL (B7)	0.000	0.000	0.000	0.000	0.000	0.000	0.000	0.000	0.000	0.000	0.000	0.000	0.000	0.000	0.000	0.000	0.000	0.000	0.000	0.000	0.000	0.000	0.000	0.000	0.000	0.000	0.000			
OLD HAZLETON TEST (A5)	0.000	0.000	0.000	0.000	0.000	0.000	0.000	0.000	0.000	0.000	0.000	0.000	0.000	0.000	0.000	0.000	0.000	0.000	0.000	0.000	0.000	0.000	0.000	0.000	0.000	0.000	0.000			
NEW HAZLETON TEST (A6)	0.000	0.000	0.000	0.000	0.000	0.000	0.000	0.000	0.000	0.000	0.000	0.000	0.000	0.000	0.000	0.000	0.000	0.000	0.000	0.000	0.011	0.011	0.000	0.000	0.000	0.000	0.000			
HAZLETON CONTROL (B5)	0.000	0.000	0.000	0.000	0.000	0.000	0.000	0.000	0.000	0.000	0.000	0.000	0.000	0.000	0.000	0.000	0.000	0.000	0.000	0.000	0.000	0.000	0.000	0.000	0.000	0.000	0.000			
HARDWOOD TEST (A8)	0.000	0.000	0.000	0.000	0.000	0.000	0.000	0.000	0.000	0.000	0.000	0.000	0.000	0.000	0.000	0.000	0.000	0.000	0.000	0.000	0.050	0.050	0.000	0.000	0.000	0.000	0.000			
HARDWOOD CONTROL (B8)	0.000	0.000	0.000	0.000	0.000	0.000	0.000	0.000	0.000	0.000	0.000	0.000	0.000	0.000	0.000	0.000	0.000	0.000	0.000	0.000	0.000	0.000	0.000	0.000	0.000	0.000	0.000			
SOUTH ROADSIDE (A9)	0.000	0.000	0.000	0.000	0.000	0.000	0.000	0.000	0.000	0.000	0.000	0.000	0.000	0.000	0.000	0.000	0.000	0.000	0.000	0.000	0.10	0.10	0.000	0.000	0.000	0.000	0.000			
SOUTH ROADSIDE CONTROL (B9)	0.000	0.000	0.000	0.000	0.000	0.000	0.000	0.000	0.000	0.000	0.000	0.000	0.000	0.000	0.000	0.000	0.000	0.000	0.000	0.000	0.000	0.000	0.000	0.000	0.000	0.000	0.000			
60 HERTZ TEST	0.000	0.000	0.000	0.000	0.000	0.000	0.000	0.000	0.000	0.000	0.000	0.000	0.000	0.000	0.000	0.000	0.000	0.000	0.000	0.000	0.000	0.000	0.000	0.000	0.000	0.000	0.000			
A15 TEST OVERHEAD UNDERGROUND	0.000	0.000	0.000	0.000	0.000	0.000	0.000	0.000	0.000	0.000	0.000	0.000	0.000	0.000	0.000	0.000	0.000	0.000	0.000	0.000	0.000	0.000	0.000	0.000	0.000	0.000	0.000			
A16 TEST OVERHEAD UNDERGROUND	0.000	0.000	0.000	0.000	0.000	0.000	0.000	0.000	0.000	0.000	0.000	0.000	0.000	0.000	0.000	0.000	0.000	0.000	0.000	0.000	0.000	0.000	0.000	0.000	0.000	0.000	0.000			
B15 CONTROL	0.000	0.000	0.000	0.000	0.000	0.000	0.000	0.000	0.000	0.000	0.000	0.000	0.000	0.000	0.000	0.000	0.000	0.000	0.000	0.000	0.000	0.000	0.000	0.000	0.000	0.000	0.000			
A17 TEST	0.000	0.000	0.000	0.000	0.000	0.000	0.000	0.000	0.000	0.000	0.000	0.000	0.000	0.000	0.000	0.000	0.000	0.000	0.000	0.000	0.053	0.053	0.000	0.000	0.000	0.000	0.000			

* BOTH ANTENNAS TRANSMITTING A 76 HZ HSK SIGNAL AT 300A AND 291° PHASING
KEY: A = NO MEASUREMENT TAKEN, B = < 0.001 GAUSS, C = SITE ABANDONED

4. ELECTRIC FIELD MEASUREMENTS

Both the low impedance electric field (the horizontal electric field earth's surface) and the high impedance electric field (the field in air) have been measured at each of the test and control plots. The low impedance electric field has been measured each year since 1972. The high impedance electric field was first measured in 1975 because of the recent interest in fields of this type under high voltage lines, and to more completely define the electric field environment for the test and control plots. The high impedance fields were not measured in 1976 and 1977, as previously mentioned, due to equipment and time limitations.

The mechanisms by which an electric field in the earth and an electric field in air can induce electric current in biological objects differ. When a life form is in contact with the earth, the electric field in the earth can cause current flow in that life form via the conductive contact. Since this can be a low impedance contact and the source impedance of the earth is relatively low, the fields in the earth have been termed "low impedance" fields. In addition to this mechanism for current flow, the electric field in air terminates on the surface of the life form, inducing current flow. At ELF frequencies, the current induced by this mechanism is relatively low and the source impedance is quite high. The fields in air are thus termed "high impedance". For this reason, the terms "low impedance" and "high impedance" are used to differentiate the two types of electric field measurements.

Since the high impedance electric field measurement includes a vertical component, it will be substantially different than the low impedance probe wire measurements whenever a significant vertical field component exists. A significant vertical field component is present beneath the overhead WTF antennas because of the operating voltage to ground of these antennas. This is similar to the vertical field which exists under overhead power lines. This field will not be a characteristic of insulated, buried ELF antennas because the operating voltage will appear across the antenna insulation and not the surrounding air space.

4.1 Low Impedance Electric Field

The low impedance electric field (the horizontal electric field at the earth's surface) was measured with one-meter probe wires. Tables 3 and 4 give the measured low impedance electric fields at the oxygen consumption and soil arthropod sites, respectively, for the period 1972-1977.

The 45- and 75-Hz readings show some fluctuation that may be explained, in part, by uncertainty in placement of the sensor. However, since the electric field varies as the natural logarithm of the inverse of the distance from the antenna, this cannot account for all of the differences from year to year. The main explanation for the yearly variations in these data is that the low impedance electric field is more affected by the differences in the earth's conductivity and other factors such as nearby long conductors which occur between measurements.

The maximum electric field levels measured in 1977 are similar to the field levels measured in previous years due to the operation of the antenna element nearest the measurement site. The minimum electric field levels for 1977 were generally on the order of the field levels measured in previous years due to the operation of the antenna element furthest from the measurement site. Again, these results are not unexpected as the antenna element nearest a measurement point will dominate the field levels at that point.

The 60 Hz fields are quite variable because they depend, in large part, upon conditions which cannot be controlled. The 60 Hz field depends on the current in nearby power lines, the quality of residence and pole grounds, the placement of power lines, and the amount of current allowed to flow in power system neutrals. Of all these factors, the only one that remains relatively constant from year to year is the placement of the lines. Even this may change, however, as power systems are upgraded and expanded.

The measurements obtained at the 60 Hz test location deserve some comment. It will be noticed that there is a fairly large 45- and 75-Hz electric field at this point. The reason for this is that the WTF transmitter obtains power from the power substation that neighbors this test point. This condition should not affect the validity of this test location since the 60 Hz fields are over an order of magnitude higher than the 45- and 75-Hz fields.

4.2 High Impedance Electric Field

Tables 5 and 6 give the high impedance electric fields (i.e., the field in air) measured at the oxygen consumption and soil arthropod sites in 1975. The measurements at each site were taken with the IITRI fabricated electric field probe. Three perpendicular components of the field were measured (north-south, east-west, and vertical) with the probe approximately three feet above the ground. The root of the sum of the squares of the measurements were taken and multiplied by the appropriate conversion factor. The results are given in the tables. This type of measurement was not undertaken prior to 1975. The measurements were not repeated in 1976 and 1977 because of equipment and scheduling difficulties.

As demonstrated by the data given in Tables 5 and 6, the high impedance electric field intensity varies greatly. There are basically three reasons for this behavior:

- 1) The highest intensity high impedance electric fields are confined to the area directly under the antenna cables, as is shown by the measurements at GG Test, North Leg, New Clover Test, Old Clover Test, the Hazleton Tests and others. In counter example, South Roadside Test has a low field in air due to the fact that the antenna is underground at this point.
- 2) Objects that are conducting relative to air can short out the high impedance fields. For this reason, people, structures, trees, and tall plants reduce the measured vertical fields nearby.
- 3) Long, thin objects that are conducting relative to air can concentrate the field many times in the direction of the longest axis. Therefore, the field directly above a plant stalk could be enhanced many times.

All of the above considerations contribute to the wide range of high impedance electric field intensities found in the data.

Table 5

HIGH IMPEDANCE ELECTRIC FIELDS MEASURED AT TEST AND CONTROL PLOTS
(OXYGEN CONSUMPTION) ANTENNAS AT 300 AMPERES

1975

Test Location	High Impedance Electric Field Intensity (volts/meter)				
	E/W Antenna		N/S Antenna		60 Hz
	45 Hz	75 Hz	45 Hz	75 Hz	
Redworm Test } Salamander Test }	0.0055	a	0.0029	0.413	0.0013
Salamander Control	0.0028	0.0015	0.0087	0.0017	0.0051
Ant Test	0.0179	0.0083	1.36	3.81	a
Ant Control	0.0011	0.0017	0.0010	0.0023	0.0020
South Roadside Test	0.0198	0.0156	0.162	0.328	0.490
Earthworm Test } Isopod Test }	0.0099	0.0100	1.57	1.97	a
N. Yard Control	0.0006	0.0011	0.0008	0.0015	0.0238
Dam Control	0.0015	0.0038	0.0012	0.0077	0.0131
M Yard Control	0.0032	0.0025	0.0035	0.0013	0.242

a = < 0.00005 volt/meter

Table 6

HIGH IMPEDANCE ELECTRIC FIELDS AT TEST AND CONTROL PLOTS (SOIL ARTHROPODS)
 Antenna Current 300 Amperes
 1975

Site	High Impedance Electric Field Strength (volts/meter)				
	E/W Antenna		N/S Antenna		60 Hz
	45 Hz	75 Hz	45 Hz	75 Hz	
Main test (A1a)	6.89	1.12	0.0326	0.0391	0.0010
Main test (A1b)	0.227	0.251	0.0241	0.0391	0.0009
Main test (A1c)	5.48	1.33	0.0261	0.0463	0.0014
Main control (B1a)	0.0037	0.0036	0.0014	0.0014	0.0020
Main control B1b)	0.0069	0.0042	0.0014	0.0011	0.0015
Main control B1c)	0.0038	0.0044	0.0016	0.0019	0.0008
Old clover test (A2)	11.4	1.07	0.0302	0.0837	0.0033
New clover test (A10)	0.0488	0.170	8.10	157.0	0.0040
Clover control (B2)	0.0274	0.0131	0.0301	0.0166	0.158
GG test (A12)	0.0549	9.11	0.0010	0.0320	0.0036
North Leg Test (A7)	0.0036	0.0163	0.995	2.22	0.0087
North Leg Control (B7)	0.0040	0.0054	0.0044	a	0.0086
Old Hazleton Test (A3)	0.0038	0.0051	2.14	3.79	0.0017
New Hazleton Test (A4)	0.0022	0.0022	0.391	1.03	0.0009
Hazleton control (B3)	0.0056	0.0012	0.0252	0.0015	0.0009
Hardwood test (A8)	0.0046	0.0100	0.0901	0.176	0.0003
Hardwood control (B8)	0.0027	0.0023	0.0050	0.0036	0.0045
South Roadside Test (A9)	0.0198	0.0156	0.162	0.327	0.490
South Roadside control (B9)	0.0056	0.0025	0.0031	0.0007	0.0175
60 Hertz Test	0.0247	0.171	0.0245	0.132	0.0542

a = < 0.00005 volt/meter

REFERENCES

1. B. Greenberg, "Oxygen Consumption in Four Species of Invertebrates and a Vertebrate Naturally Exposed to Sanguine Fields," Final Report, University of Illinois at Chicago Circle, 25 January 1973.
2. B. Greenberg, "Oxygen Consumption in Four Species of Invertebrates and a Vertebrate Naturally Exposed to Sanguine Electromagnetic Fields," Final Report, University of Illinois at Chicago Circle, May 1974.
3. B. Greenberg, "Oxygen Consumption and Respiratory Quotient in Five Animal Populations Naturally Exposed to Sanguine Electromagnetic Fields," Report University of Illinois at Chicago Circle, March 1975.
4. B. Greenberg, "Metabolic Rates in Five Animal Populations after Long-Term Exposure to Sanguine/Seafarer ELF Electromagnetic Fields in Nature," Report, University of Illinois at Chicago Circle, April 1976.
5. B. Greenberg, "Metabolic Rates in Five Animal Populations in 1976 After Prolonged Exposure to Seafarer ELF Electromagnetic Fields in Nature," Report, University of Illinois at Chicago Circle, August 1977.
6. B. Greenberg, "Impact of Extremely Low Frequency Electromagnetic Fields on Soil Arthropods - Ongoing Studies at the Wisconsin Test Facility," Final Report, University of Illinois at Chicago Circle, 25 January 1973.
7. B. Greenberg, "Impact of Extremely Low Frequency Electromagnetic Fields on Soil Arthropods. Ongoing Studies at the Project Sanguine Wisconsin Test Facility, 1973," Report, University of Illinois at Chicago Circle, May 1974.
8. B. Greenberg, "Sanguine/Seafarer Extremely Low Frequency Electromagnetic Fields: Effect of Long-Term Exposure on Soil Arthropods in Nature," Report, University of Illinois at Chicago Circle, July 1976.
9. B. Greenberg, "Seafarer Extremely Low Frequency Electromagnetic Fields: Soil Arthropod Populations After Long-Term Exposure Under Natural Conditions," Report, University of Illinois at Chicago Circle, August 1977.
10. B. Greenberg and N. Ash, "Impact of Extremely Low Frequency Electromagnetic Fields on Soil Arthropods," Environmental Entomology, 1(1972), 743-50.
11. B. Greenberg and N. Ash, "Do Extremely Low Frequency Electromagnetic Fields Affect Soil Arthropods? Ongoing Studies at the Wisconsin Test Facility," Environmental Entomology, 2(1973), 643-52.
12. B. Greenberg and N. Ash, "Impact of Extremely Low Frequency Electromagnetic Fields on Soil Arthropods in Nature," Environmental Entomology, 3(1974), 845-53.
13. B. Greenberg and N. Ash, "Extremely Low Frequency Electromagnetic Fields of Project Sanguine/Seafarer: Effect of Long-Term Exposure on Soil Arthropods in Nature," Environmental Entomology, 5(1976), 1033-1039.

REFERENCES (Cont.)

14. B. Greenberg and N. Ash, "Extremely Low Frequency Antenna Operation: Tests for Possible Impact on Five Naturally Exposed Animal Populations," Journal of Invertebrate Pathology, 23(1974), 366-70.
15. B. Greenberg and N. Ash, "Metabolic Rates in Five Animal Populations After Prolonged Exposure to Weak Extremely Low Frequency Electromagnetic Fields in Nature," Radiation Research, 67(1976), 252-265.
16. V. Formanek, "An Improved ELF Electric Field Probe," IIT Research Institute Technical Memorandum E6249-2 (March 1974).

APPENDIX A

**SOIL ARTHROPOD AND OXYGEN CONSUMPTION TEST AND CONTROL SITES
IN THE AREA SURROUNDING THE WISCONSIN TEST FACILITY**

IIT RESEARCH INSTITUTE

A description of the location of each biological site can be found in the following pages. Figure A-1 gives the relative location of each site with respect to the Sanguine/Seafarer ELF antenna. Brief maps showing the location of each site in more detail are presented in Figures A-2 through A-16.

A number of changes occurred in the test and control plots in 1976 and 1977. In 1976 two sites (#14--Ant Test, and #22--Ant Control) were abandoned as the collection and studies of ants were no longer being made. In addition, a new soil arthropod site (#27--Dam Dump Control) was selected and utilized this year. In 1977 one site was abandoned (#26--60 Hz Test) and four new sites were selected. The new sites were #28--B15 Control, #29--A15 Test, #30--A16 Test, and #31--A17 Test.

Electromagnetic field measurements were not made at the abandoned sites following their abandonment.

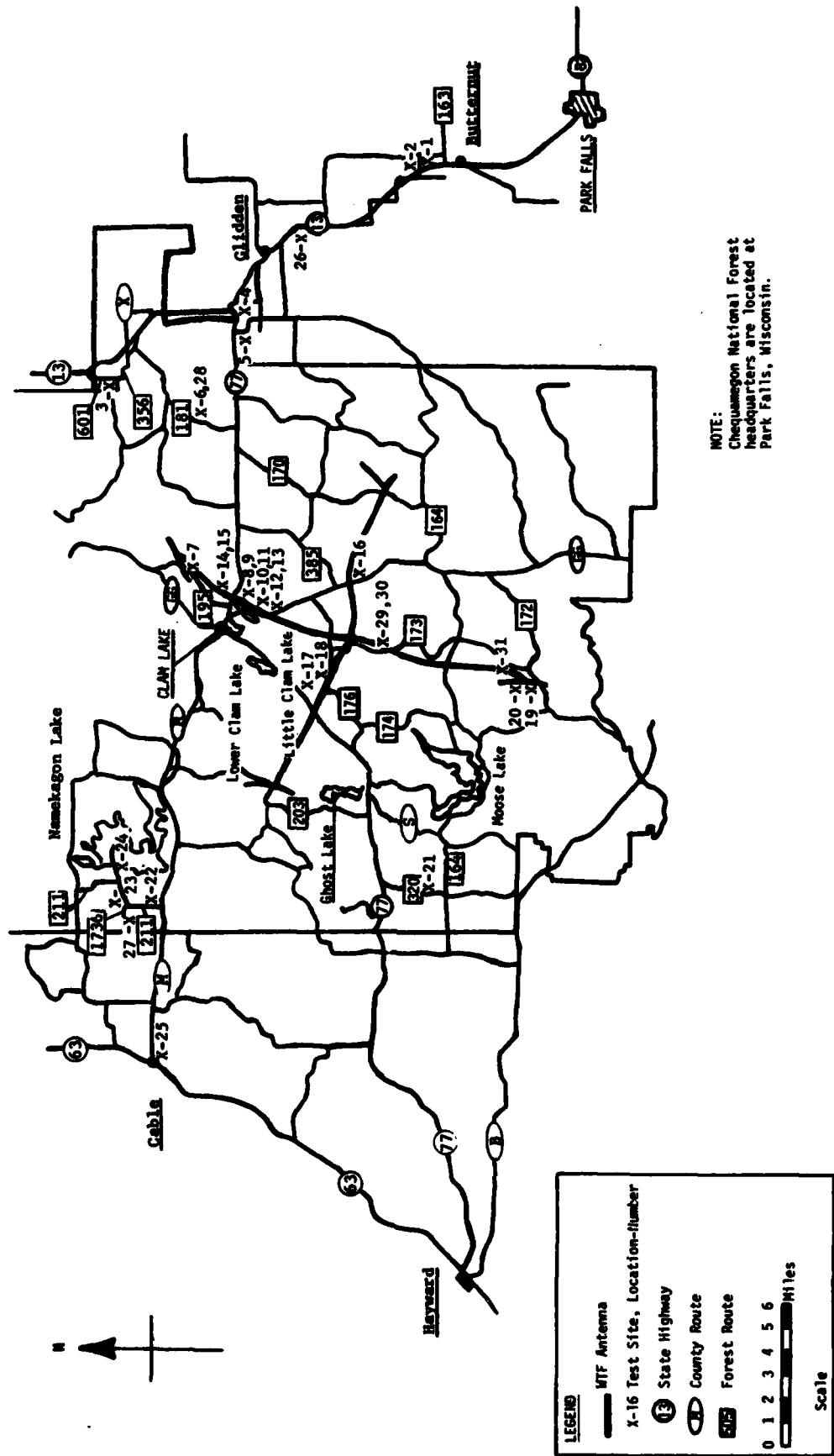

FIGURE A-1 LOCATION OF THE OXYGEN CONSUMPTION AND SOIL ANTHROPOD TEST AND CONTROL SITES AND THE ELF ANTENNA IN THE CHEQUAMEGON NATIONAL FOREST, WISCONSIN.

SITE #1--CLOVER CONTROL. This site is located on an unmarked dirt road east of Highway 13, 7 miles south of Glidden and 1 mile north of Forest Road 163. The site is on south side of road near gas pipeline valve - about 100 yards from Highway 13.

SITE #2--NORTH LEG CONTROL. This site is located across the road from, and about 75 feet west of Clover Control. The site is about 25 feet from the road in a slightly swampy area.

SITE #3--HARDWOOD CONTROL. This site is located on Thole Road (601) about 300 yards north of Darrow Road (356). Forest Road 356 starts at the second junction of Highway 13 and County X, north of Glidden. The site is about 50 feet into the woods and is marked from the road by a tree shaped like a "V".

SITE #4--SOUTH ROADSIDE CONTROL. This site is located on Highway 77, 12.8 miles east of GG. The site is on the south side of the road about 50 yards west of the Whispering Pines bar, near junction of Highways 13 and 77.

SITE #5--SALAMANDER CONTROL. This site is located 12 miles east of GG on Highway 77 on an unmarked dirt road going south. When going west on 77 it is the first road on the left from the Whispering Pines. The road is on the top of a hill. The site is along the west shoulder of the road, about 25 yards from 77.

SITE #6--MAIN CONTROL 1, 2, and 3, and SITE #28--B15 CONTROL. These sites are located 2.6 miles north of Highway 77 on Forest Road 181. The sites are on the east side of the road in a small clearing. Some birch trees are marked with green paint.

SITE #7--NORTH LEG TEST. This site is located about 2.5 miles north of Highway 77 on Forest Road 195 (marked 186 on road sign, 195 on post). The site is accessed by taking the second overgrown road to the right off of 195. The test plot is back in the right-of-way near the stockade for the north ground.

SITE #8--SOUTH ROADSIDE TEST. This site is located where the north antenna crosses Highway 77 about 0.9 mile east of GG. The site is on the south side of the road next to the buried cable marker.

SITE #9--SALAMANDER TEST; SITE #10--REDWORM TEST. These sites are located along the right-of-way just south of Site #8. This is the area where the antenna is underground. The test plot is not well defined as the entire area is used for specimen collecting. Measurements were taken about 50 feet from the entrance gate off the east side of the right-of-way.

SITE #11--EARTHWORM TEST; SITE #12--ISOPOD TEST. This site is located in the north antenna right-of-way south of Highway 77. The test plot (unmarked) is a large cluster of rocks on the east side of the right-of-way between the second and third antenna pole.

SITE #13--HARDWOOD TEST. This site is located in the north antenna right-of-way south of Highway 77. The test plot is in the forest about 50 feet east of the third antenna pole. The plot is marked with stakes.

SITE #14--ANT TEST. This site is located in the north antenna right-of-way north of Highway 77. The test plot is along the west edge of the right-of-way between the second and third pole and consists of a rocky and sandy area.

SITE #15--NEW CLOVER TEST. This site is located in the north antenna right-of-way north of Highway 77. The test plot is found almost directly under the antenna near the third pole.

SITE #16--GG TEST. This site is located at the point where the east leg of the antenna crosses GG, about 1.8 mile south of 176. The test plot is next to the pole where the antenna goes underground on the east side of the road.

SITE #17--MAIN TEST 1, 2, and 3; SITE #18--OLD CLOVER TEST. These sites are located at the point where the west leg of the antenna crosses 176. The test plots are in the right-of-way on the west side of the road between the first and second poles.

SITE #19--OLD HAZLETON TEST; SITE #20--NEW HAZLETON TEST. These sites are located where the south leg of the antenna crosses 172, about 0.35 mile west of 173. The Old Hazleton plot is near a red and white survey marker about 50 feet south of the stockade in the right-of-way north of 172.

The new Hazleton plot is 1½ poles past the stockade, past a large stump on the east side of the right-of-way, and 15-20 feet behind a tree marked with green paint.

SITE #21--HAZLETON CONTROL. This site is located about 0.5 mile north of 164 on 320 (west of Moose Lake). The test plot is on the east side of the road about 30 feet into the forest.

SITE #22-ANT CONTROL. This site is located on Forest Road 211 north of County M. This is the road to the Four-Seasons restaurant. The test plot is about 0.5 mile north of M on the east side of the road in a large sandy clearing.

SITE #23--DAM CONTROL. This site is located on 211 on the west side of the road just north of the bridge/dam. The test plot is on the north side of a turn-around circle and picnic area.

SITE #24--N YARD CONTROL. This site is located next to one of Junek's cabins. Follow the road straight to the Four-Seasons where 211 turns left. Then take the first road to the right (again to the Four Seasons) . Take another right at the second dirt driveway. The plot is near the second cabin.

SITE #25--M YARD CONTROL. This site is located in Cable in the yard of a house along M. The house is across from a triangle formed by M and two city streets. The test plot is behind the garage next to the garden.

SITE #26--60 Hz TEST. This site is located at the substation on the west side of Highway 13 just southeast of Glidden. The test plot is on the south-east side of the fenced area around the substation.

SITE #27--DAM DUMP CONTROL. This site is located at the far end of an abandoned dump at the end of Forest Road 1730, west off Forest Road 211.

SITE #29--A15 TEST and SITE #30--A16 TEST. These sites are located on the east side of Forest Road 173, about .7 mile south of the driveway to the WTF compound. A short access road leads to the antenna right-of-way for the south leg of the antenna. A15 Test is located about 20 yards north of pole 15; A16 Test is located about 50 yards south of pole 14.

SITE #31--A17 TEST. This site is located about 25 feet south of pole 16 of the south leg of the antenna. The antenna right-of-way is accessed by taking Forest Road 1663 west from Forest Road 173.

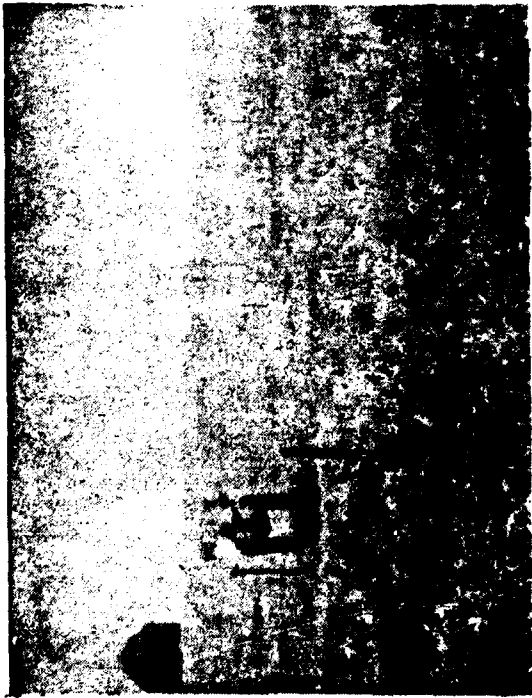

View To NE From Road

Site #1 Clover Control



View To East From Road



Site #2 North Leg Control Looking NNW From Road

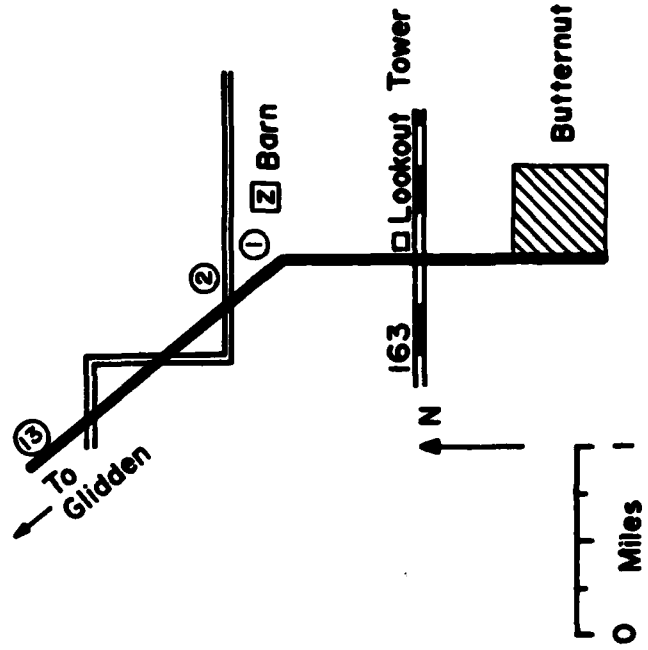
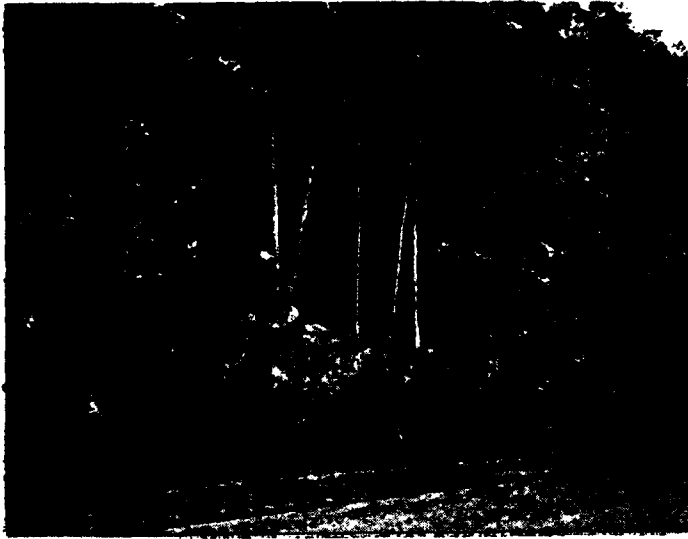
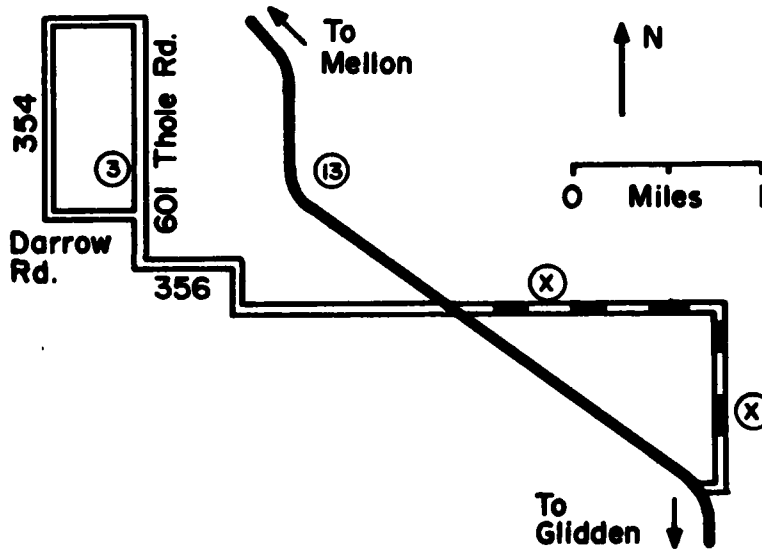

FIG. A-2 SITE #1 CLOVER CONTROL AND SITE #2 NORTH LEG CONTROL



Looking NW From
Thole Rd.



Actual Site Behind
Tree Shaped Like
a 'V'.

Fig. A-3 HARDWOOD CONTROL SITE *3



View NW On Route 13



View NE From Route 13

Site # 4 South Roadside Control



Site # 5 Salamander Control View
South From Route 77

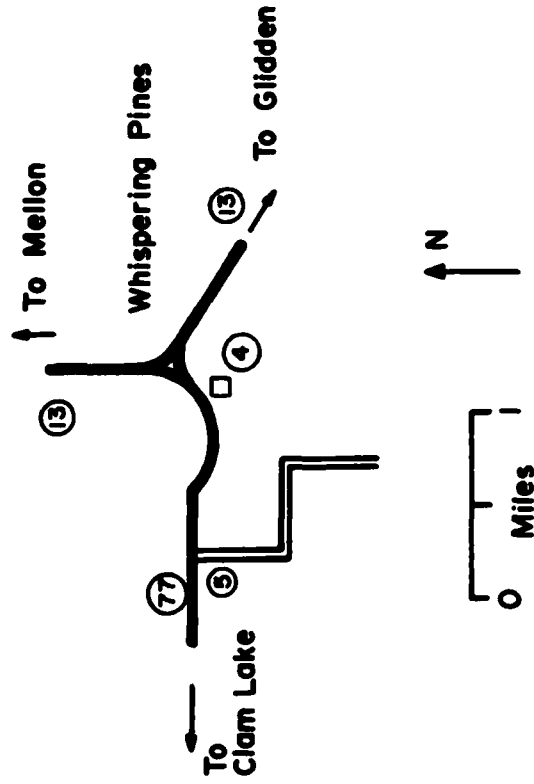

FIG. A-4 SITE #4 SOUTH ROADSIDE CONTROL AND SITE #5 SALAMANDER CONTROL



View NE From 181



View East From 181

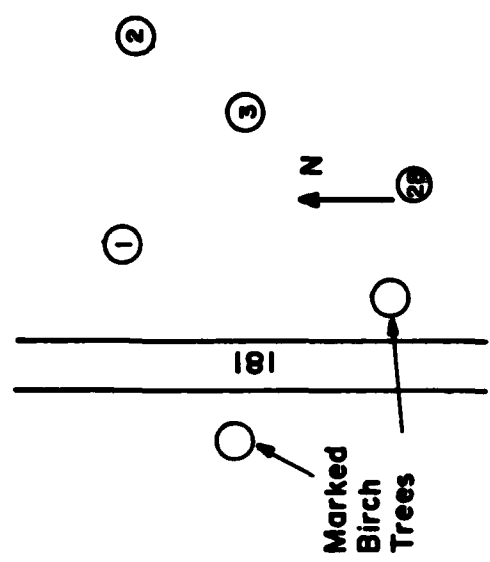
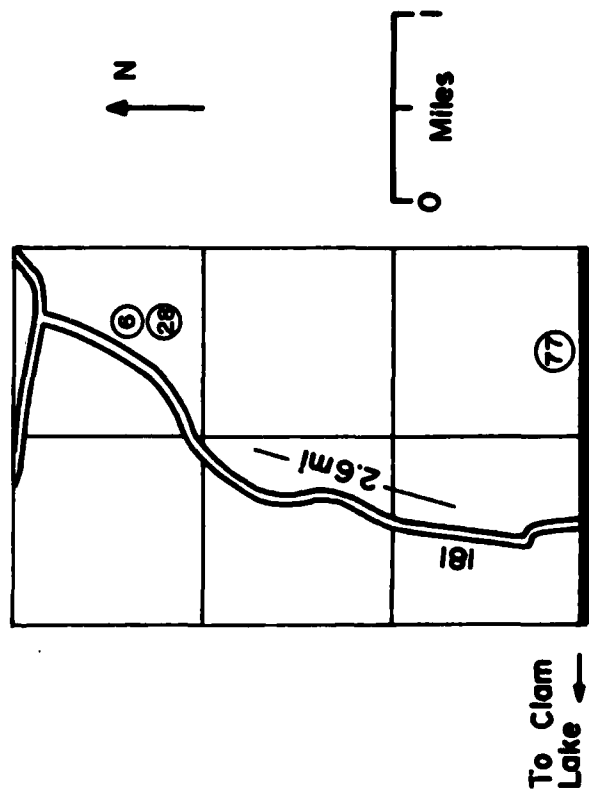

FIG. A-5 SITE #6 MAIN CONTROL 1,2,3 AND SITE #28 B15 CONTROL



Site # 8 South Roadside Test



Sites # 9 & #10 Salamander & Redworm Test



Sites #11 & #12 Earthworm and Isopod Test

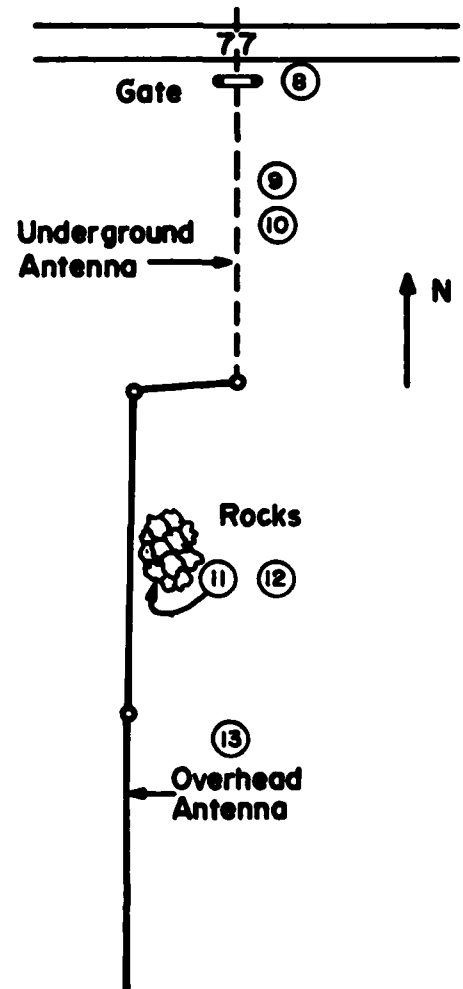
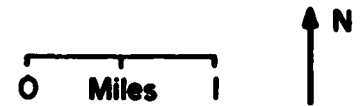
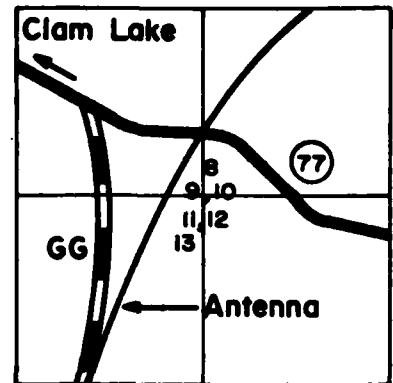
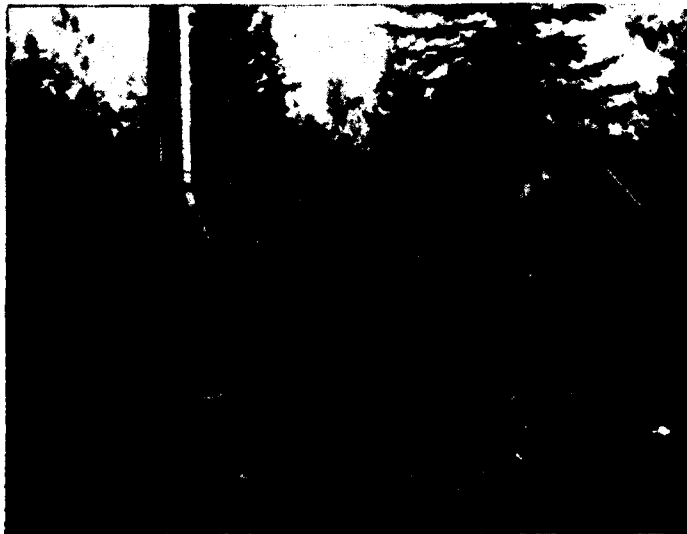

Fig.A-6 SITES # 8 - #12



**Site #13 Hardwood Test
View East From Antenna**



**Site #16 GG Test
View East Showing Cable Going Underground**

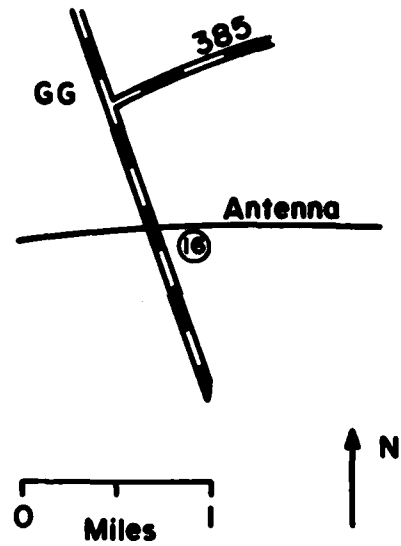
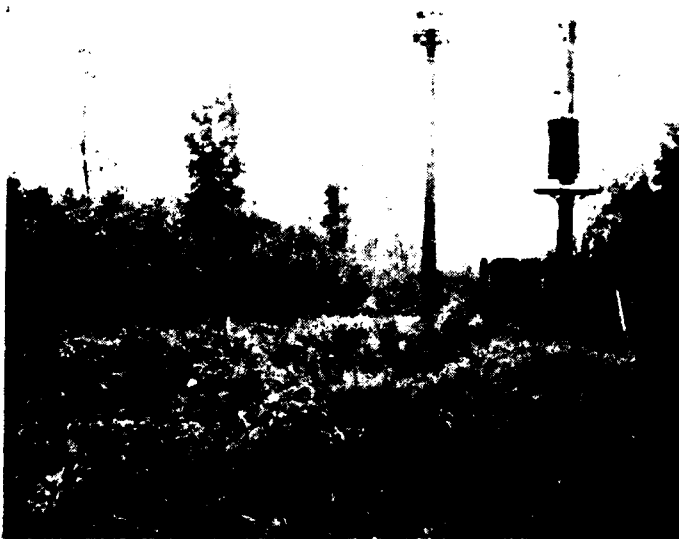
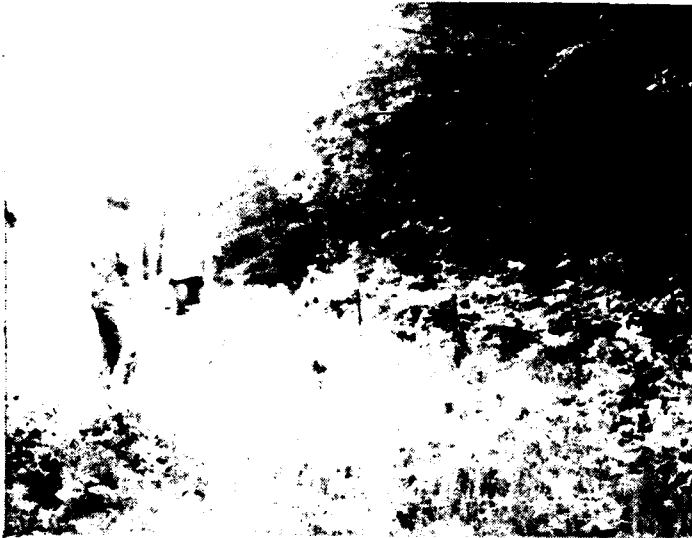

Fig.A-7 SITE #13 HARDWOOD TEST AND SITE #16 GG TEST



Site #7 North Leg Test

View South
From
Right Of Way



Site #15 New Clover Test



Site #14 Ant Test View West From Antenna

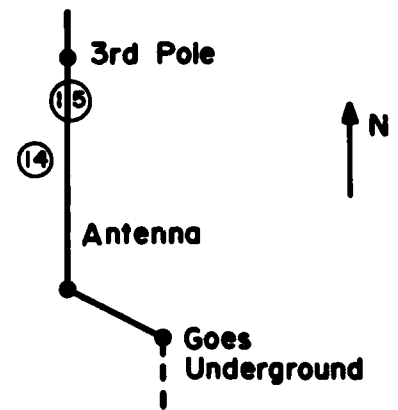
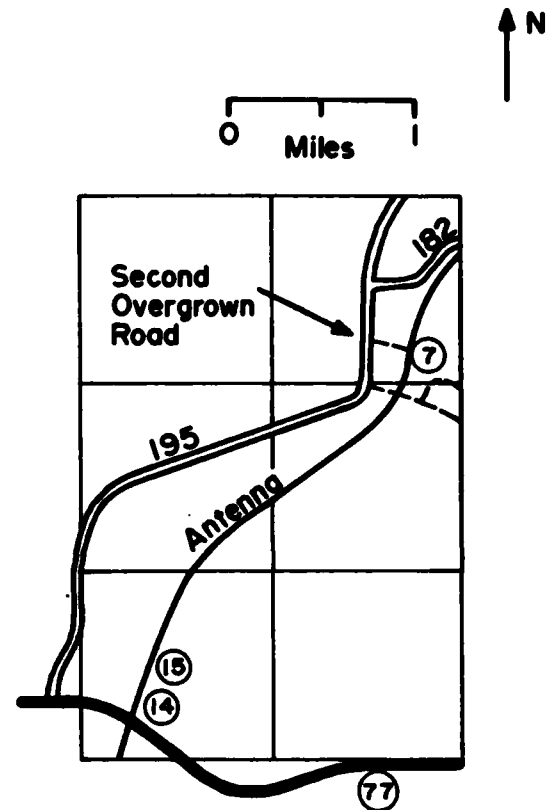

Fig.A-8 SITE #7 NORTH LEG TEST, SITE #15 NEW CLOVER TEST, AND SITE #14 ANT TEST.



Main Test #1 (Note Overhead Antenna)



Old Clover Test - View West

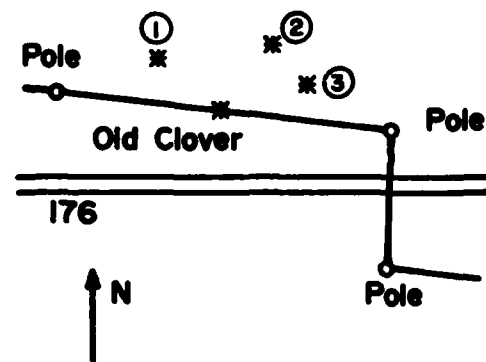
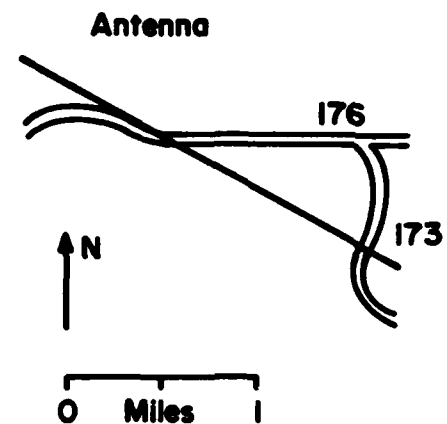

Main Test 2 (Foreground)

Main Test 3 (Behind Tree)
View Northeast From Right -
Of-Way

Fig.A9 SITE #17 MAIN TEST AND #18 OLD CLOVER TEST



Site # 20 New Hazelton Test
View East From Right Of Way

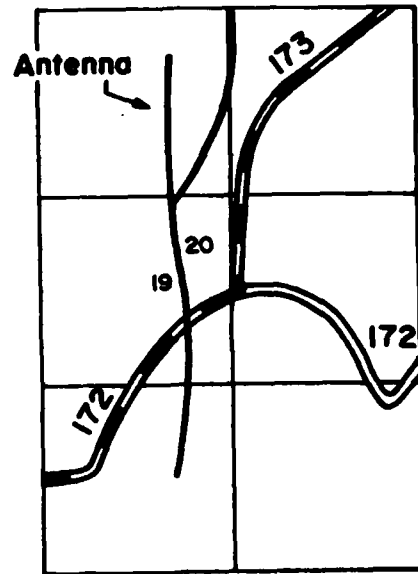

Site # 19 Old Hazelton Test
View West From Right Of Way

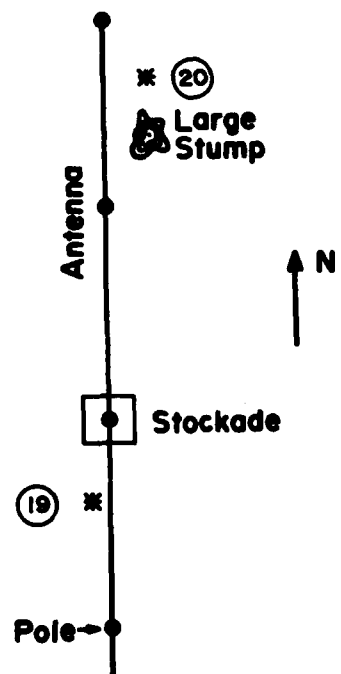
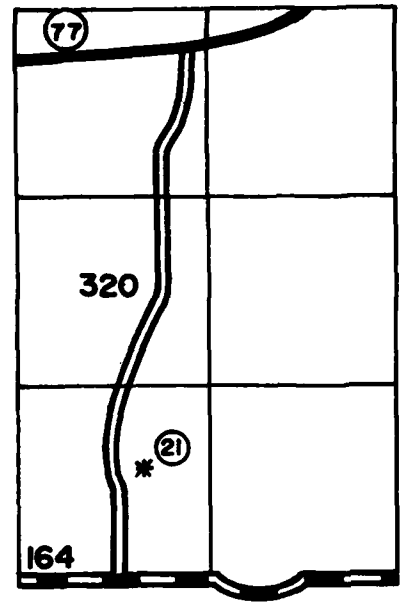

Fig.A-10 HAZELTON TEST SITES #19 & #20

↑ N
 Site # 21
 Hazelton
 Control



0 Miles 1

Site # 25 M Yard Control - View East
 From Triangle



Location of Test Plot Behind Garage
 View South

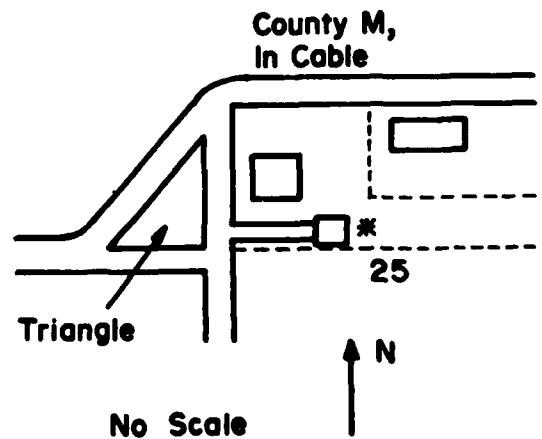
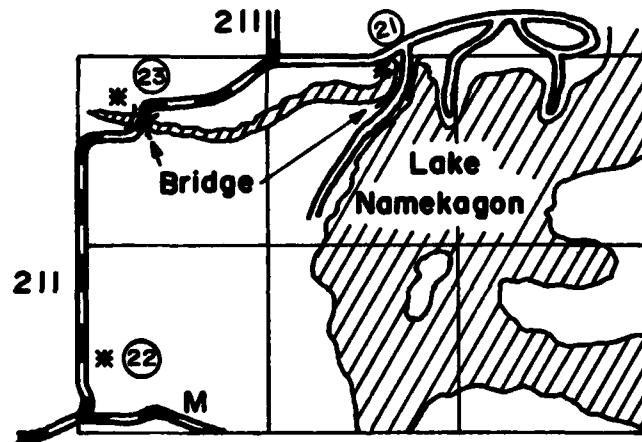

Fig. A-II SITE #21 HAZELTON CONTROL AND SITE #25 M YARD CONTROL



Site #22
Ant Control
View East From 211



Site #22
Ant Control
Close Up Of Above
Photograph

Fig.A-12 SITE #22 ANT CONTROL

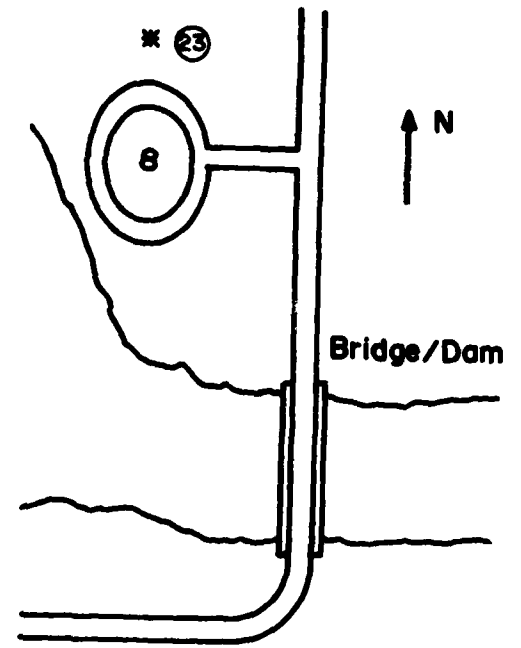

Site # 23 Dam Control, View West From 211

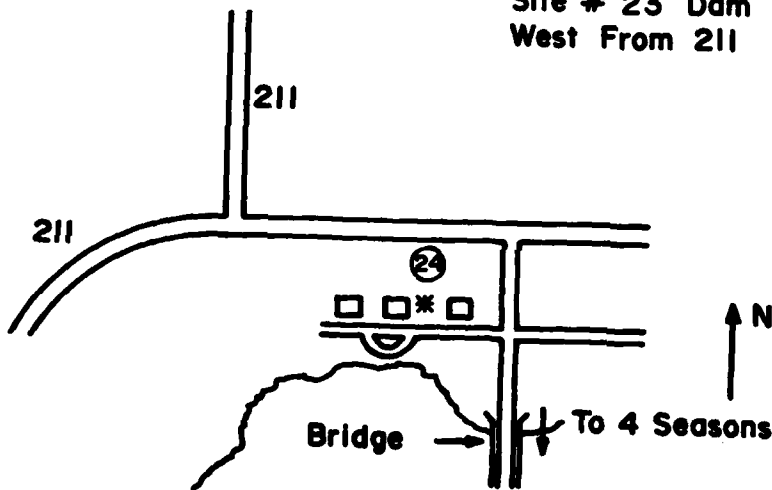

Site #24 N Yard Control, View North From Turnaround Circle

Fig.A-13 SITE #23 DAM CONTROL AND SITE #24 N YARD CONTROL

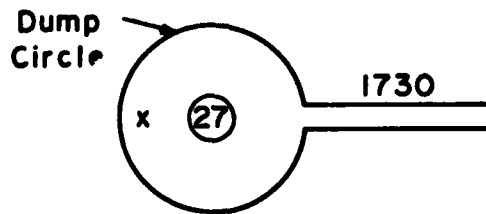
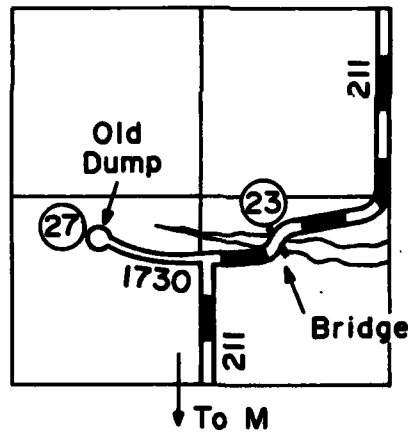
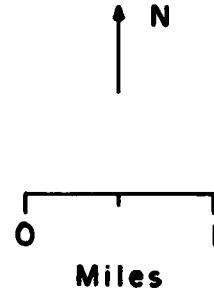
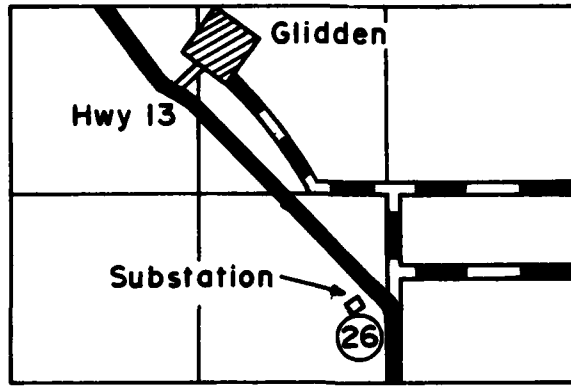
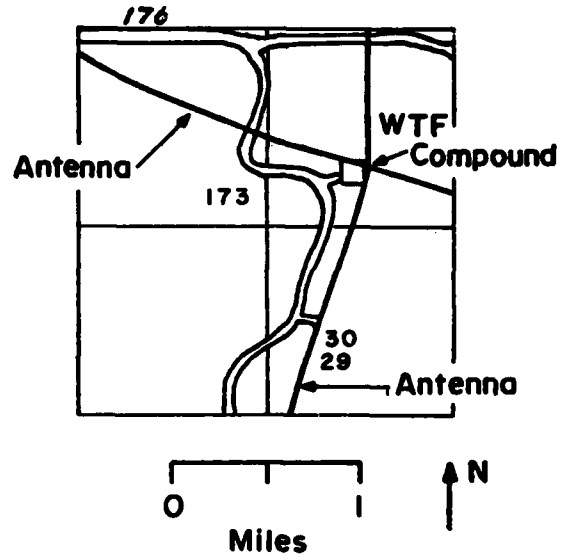

Fig. A-14 **SITE # 26** **60 Hz** **TEST**
 SITE # 27 **DAM DUMP** **CONTROL**



Site #29 A15 Test
View South To Pole 15



Site #30 A16 Test
View North To Pole 14

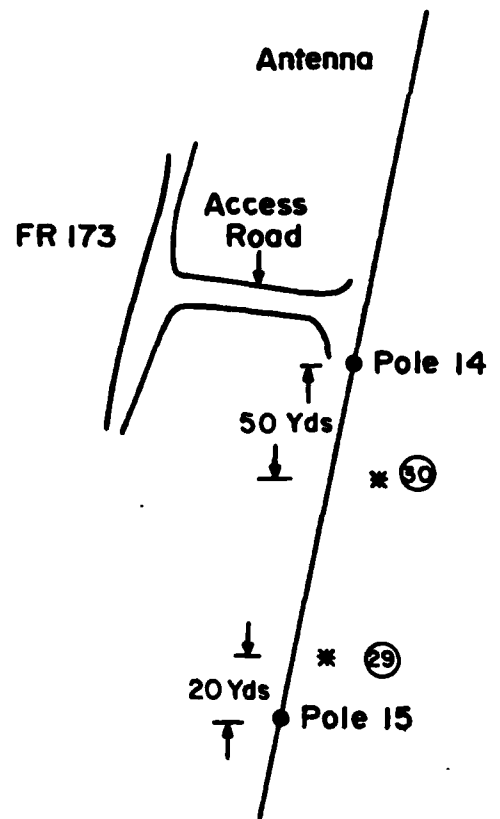

Fig. A-15 SITE #29-A15 TEST AND SITE #30-A16 TEST



SITE #31 A17 Test
View North Showing Pole 116

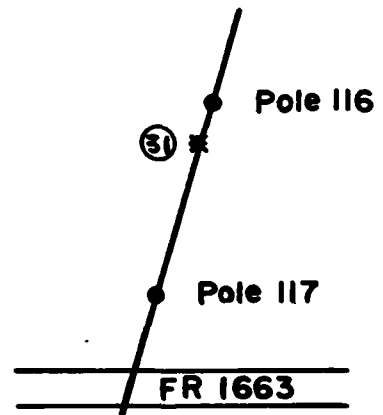
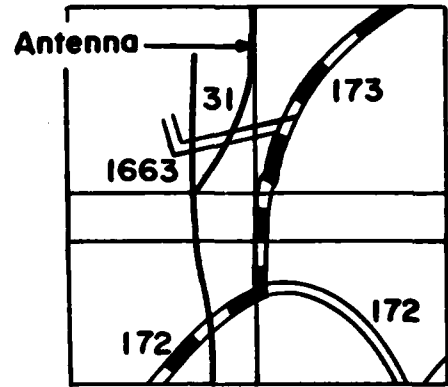

Fig. A-16 SITE #37 - A17 TEST

APPENDIX B

**SUMMARY OF OPERATION OF THE WISCONSIN TEST FACILITY
FOR THE PERIOD JUNE 1971 TO JUNE 1977**

IIT RESEARCH INSTITUTE

Tables B1 through B6 give the total hours of operation per month of the Wisconsin Test Facility for the period of June 1971 through May 1977. The data are divided into frequency spans of 41 to 49 Hz and 71 to 79 Hz. Each frequency span is further partitioned to indicate which antenna elements were being used. Single frequency operation is assumed for all tables unless MSK modulated transmission is specially noted.

TABLE B1
WTF Operation For June 1971 To June 1972

Month - Year	Hours Of Operation Per Month									
	41, 42, 43, 44, 45, 46, 47 or 49 Hz					71, 72, 73, 74, 75, 76, 77, or 79 Hz				
	E/W	N/S	Both	NSB	E/W	N/S	Both	NSB	NSB+E/W	
June 1971	17.5/.75 ^Δ	17.5/.75 ^Δ	17.5/.75 ^Δ	-	21./75 ^Δ	21./75 ^Δ	21./75 ^Δ	-	-	
July	15.	15.	15.	-	19./2. ^Δ	19./2. ^Δ	19./2 ^Δ	-	-	
Aug.	25.	25.	25.	-	26.	18.5/5. ^Δ	18.5	-	-	
Sept.	26.	26.	26.	-	16.5	11./5.5 ^Δ	16.5	-	-	
Oct.	-	-	139.5	-	-	-	208.	-	-	
Nov.	-	-	85.5	-	-	-	30.5	-	-	
Dec.	-	-	81.5	-	-	-	66.5	-	-	
Jan. 1972	-	-	2.5	-	27.	-	42.	-	-	
Feb.	-	-	22.5	-	63	-	15.	-	-	
March	-	-	7.5	-	90.5	-	48.	-	-	
April	-	-	-	-	55.	-	21.	-	-	
May	-	-	75.	-	-	-	277.	-	-	

Notes:
 Antenna current = 300 A unless otherwise noted
 E/W = East/West Antenna
 N/S = North/South Antenna
 Both = East/West and North/South Antennas
 NSB = North/South Buried Antenna
 NSB+E/W = North/South Buried + East/West Antennas
 Δ = Antenna output = 150 A

TABLE B2
WTF Operation For June 1972 To June 1973

Month - Year	Hours Of Operation Per Month												
	45 Hz						75 or 76 Hz						
	E/W	N/S	Both	NSB	E/W	N/S	Both	NSB	E/W	N/S	Both	NSB	NSB+E/W
June 1972	9.5	9.5	9.5	-	12.5	12.5	12.5	-	12.5	12.5	12.5	-	-
July	16.5	2.	1.5	-	75.			-			22.5*	-	-
Aug.	24.5	21.5	21.5	-	21.			-	21.	21.5*	21.5*	-	-
Sept.	-	-	-	-	4.5			-	4.5	3.75	219.5*	-	-
Oct.	.5	2.	20.	-	16.			-	16.	1.	24.5/30*	-	-
Nov.	53.	-	-	-	61.5/7.5*			-	61.5/7.5*	-	5.5*	-	-
Dec.	7.5	-	-	-	5.5			-	5.5	-	240.*	-	-
Jan. 1973	43.5	7.5	-	-	56.5			-	56.5	37.5	-	-	-
Feb.	-	30.	-	-	-			-	-	127.5	-	-	-
March	-	-	-	-	12.			-	12.	102.	-	-	-
April	-	-	-	-	75.			-	75.	54./28.∇	-	61.5∇	7.5+
May	8.	8	-	-	75.5			-	75.5	16.5	-	-	60.+

Notes:
 Antenna current = 300 A unless otherwise noted
 E/W = East/West Antenna
 N/S = North/South Antenna
 Both = East/West and North/South Antennas
 NSB = North/South Buried Antenna
 NSB+E/W = North/South Buried + East/West Antennas

* = 76 Hz MSK Modulated Signal
 Δ = Antenna Current = 210 A
 ∇ = Antenna Current = 260 A
 + = NSB at 260 A, E/W at 300 A

TABLE B3
WTF Operation For June 1973 To June 1974

Month - Year	Hours Of Operation Per Month									
	42, 44, or 45 Hz					75 or 76 Hz				
	E/W	N/S	Both	NSB	E/W	N/S	Both	NSB	NSB+E/W	
June 1973	8.	2.	-	6.∇	51.	8.	-	65.∇/9.∇*	-	
July	6.5/2.Δ	41.5	-	1.∇	9./20.5∇	16.5/8*/26.Δ	-	.25††	-	
Aug.	15.Δ	15.Δ	-	-	10./7.Δ	16.5	-	10.∇	16.5+	
Sept.	-	-	-	-	5.5	4.	131.	7.∇	6.+	
Oct.	-	-	-	-	83.5	17.	8.	9.5∇	-	
Nov.	-	-	22.5	-	74.	-	75.	-	-	
Dec.	70.3	5.2	-	-	-	-	-	-	-	
Jan. 1974	1.5	5.	206.	-	-	-	-	-	58.5†*	
Feb.	-	-	15.	-	-	-	-	-	-	
March	-	110.5	130.	-	-	-	-	-	-	
April	-	-	-	-	-	-	-	26.5∇	-	
May	-	-	-	-	-	-	-	-	-	

Notes:

- Antenna current = 300 A unless otherwise noted
- E/W = East/West Antenna
- N/S = North/South Antenna
- Both = East/West and North/South Antennas
- NSB = North/South Buried Antenna
- NSB+E/W = North/South Buried + East/West Antennas

- * = 76 Hz MSK Modulated Signal
- Δ = Antenna Current = 50 A
- †† = Antenna Current = 200 A
- ∇ = Antenna Current = 260 A
- + = NSB at 260 A, EW at 300 A

TABLE B4
WTF Operation For June 1974 To June 1975

Month - Year	Hours Of Operation Per Month									
	42 or 45 Hz					75 or 76 Hz				
	E/W	N/S	Both	NSB	E/W	M/S	Both	NSB	NSB+E/W	
June 1974	-	-	-	-	-	-	-	-	-	-
July	-	-	-	-	-	-	64.	-	-	-
Aug.	-	-	7.5	-	-	-	163.5	-	-	-
Sept.	-	-	12.5	-	-	-	157.5	-	-	-
Oct.	-	-	2.5	-	-	-	160./35.5*	-	-	-
Nov.	-	-	20.	-	-	-	187.5	-	-	-
Dec.	-	-	59.	-	-	-	10.	-	-	-
Jan. 1975	-	-	246.	-	-	-	-	6.5 ^v	-	-
Feb.	-	-	230.	-	-	-	17.	-	-	-
March	-	-	165.	-	-	-	-	-	-	-
April	-	-	24.	-	-	-	21.*	-	-	-
May	-	-	-	-	3.5*	-	45./37.*	-	-	-

Notes:
 Antenna current = 300 A unless otherwise noted
 E/W = East/West Antenna
 N/S = North/South Antenna
 Both = East/West and North/South Antennas
 NSB = North/South Buried Antenna
 NSB+E/W = North/South Buried + East/West Antennas

* = 76 Hz MSK Modulated Signal
 v = Antenna Current = 260 A

TABLE B5
WTF Operation For June 1975 To June 1976

Month - Year	Hours Of Operation Per Month												
	42 or 45 Hz						75 or 76 Hz						
	E/W	N/S	Both	NSB	E/W	N/S	Both	NSB	E/W	N/S	Both	NSB	NSB+E/W
June 1975	19.5	19.5	1.5	-	21.5	21.5	16.	-	-	-	-	-	-
July	6.35	6.35	-	-	13.5	13.5	132.	-	-	-	-	-	-
Aug.	-	-	-	-	21.	-	147.	-	-	-	-	-	-
Sept.	-	-	-	-	5.*	-	86.5/5.*	-	-	-	-	-	-
Oct.	-	-	-	-	36./85.*	36./85.*	67.	10.5 Δ	-	-	-	-	-
Nov.	-	-	-	-	-	-	236.5	-	-	-	-	-	-
Dec.	-	-	-	-	38.5	96.5	-	-	-	-	-	-	-
Jan. 1976	-	-	-	-	-	-	-	-	-	-	-	-	-
Feb.	-	-	-	-	-	-	-	-	-	-	-	-	-
March	-	-	-	-	31.*	-	184.	-	-	-	-	-	-
April	-	-	-	-	32.5*	-	144.	-	-	-	-	-	-
May	-	-	-	-	62.*	-	-	-	-	-	-	-	-

Notes:
 Antenna current = 300 A unless otherwise noted
 Antenna E/W = East/West Antenna
 N/S = North/South Antenna
 Both = East/West and North/South Antennas
 NSB = North/South Buried Antenna
 NSB+E/W = North/South Buried + East/West Antennas

* = 76 Hz MSK Modulated Signal
 Δ = antenna current - 100 A

TABLE B6
WTF Operation For June 1976 To June 1977

Month - Year	Hours Of Operation Per Month									
	45 Hz					72, 75 or 76 Hz				
	E/W	N/S	Both	NSB	E/W	N/S	Both	NSB	NSB+E/W	
June 1976	-	-	24.5	-	77.*	-	38.	-	-	
July	-	-	33	-	4./59.*	-	4.5/76.5*	-	-	
Aug.	-	-	-	-	4.5/64.*	12.5	104/309.5*	-	-	
Sept.	-	-	-	-	-	-	656.*	24.5	29.5	
Oct.	-	-	-	-	-	13./7.5*	9.5/692.5*	-	-	
Nov.	-	-	-	-	-	-	11./547.*	-	-	
Dec.	-	-	-	-	-	-	14./516.*	-	-	
Jan. 1977	-	-	-	-	1.*	-	4./578.*	-	-	
Feb.	-	-	-	-	.5/6.*	.5/27.5*	2.5/540.5*	-	-	
March	-	-	-	-	-	-	655.*	-	-	
April	-	-	-	-	2.*	-	582.*	-	-	
May	-	-	-	-	7.5*	-	631.*	-	-	

Notes:
 Antenna current = 300 A unless otherwise noted
 E/W = East/West Antenna * = 76 Hz MSK Modulated Signal
 N/S = North/South Antenna
 Both = East/West and North/South Antennas
 NSB = North/South Buried Antenna
 NSB+E/W = North/South Buried + East/West Antennas

Unclassified

SECURITY CLASSIFICATION OF THIS PAGE (When Data Entered)

REPORT DOCUMENTATION PAGE		READ INSTRUCTIONS BEFORE COMPLETING FORM
1. REPORT NUMBER	2. GOVT ACCESSION NO. A124309	3. RECIPIENT'S CATALOG NUMBER
4. TITLE (and Subtitle) Electric and Magnetic Field Measurements at the Wisconsin Test Facility in Support of the Soil Arthropod and Oxygen Consumption Studies During 1972-1977		5. TYPE OF REPORT & PERIOD COVERED Technical, 1972-1977
7. AUTHOR(s) J. R. Gauger		6. PERFORMING ORG. REPORT NUMBER TR E6357-14
9. PERFORMING ORGANIZATION NAME AND ADDRESS IIT Research Institute 10 W. 35th Street Chicago, Illinois 60616		8. CONTRACT OR GRANT NUMBER(s) N00039-76-C-0141
11. CONTROLLING OFFICE NAME AND ADDRESS Naval Electronic Systems Command Washington, DC 20360		10. PROGRAM ELEMENT, PROJECT, TASK AREA & WORK UNIT NUMBERS
14. MONITORING AGENCY NAME & ADDRESS (if different from Controlling Office)		12. REPORT DATE April 1978
		13. NUMBER OF PAGES 45
		15. SECURITY CLASS (of this report) Unclassified
		15a. DECLASSIFICATION/DOWNGRADING SCHEDULE
16. DISTRIBUTION STATEMENT (of this Report) Unlimited Distribution		
17. DISTRIBUTION STATEMENT (of the abstract entered in Block 20, if different from Report)		
18. SUPPLEMENTARY NOTES		
19. KEY WORDS (Continue on reverse side if necessary and identify by block number) Extremely Low Frequency Soil Arthropod Sanguine Electromagnetic Field Oxygen Consumption ELF Communications Electric Field Measurement Biological Effects Magnetic Field Measurement Seafarer		
20. ABSTRACT (Continue on reverse side if necessary and identify by block number) The technical effort reported herein documents extremely low frequency (ELF) electromagnetic field measurements made at selected biological test and control plots in the Chequamegon National Forest near to and remote from the U.S. Navy's ELF Communications Test Facility in northern Wisconsin. The measurements were made in support of soil arthropod and oxygen consumption studies performed in an effort to determine possible biological effects of an ELF communications system.		

END

FILMED

3-83

DTIC