

MICROCOPY RESOLUTION TEST CHART
NATIONAL BUREAU OF STANDARDS-1963-A

ADA 124714

AIR FORCE INSTITUTE OF TECHNOLOGY

WRIGHT PETERSON AIR FORCE BASE
WRIGHT PETERSON AIR FORCE BASE
UNITED STATES AIR FORCE



①

DESIGN, FABRICATION AND INSTRUMENTATION
OF AN
ANNULAR DIFFUSER RESEARCH FACILITY.
THESIS

AFIT/GAE/AA/82D-20 RICHARD M. MOORE
 Capt USAF

DTIC
SELECTE
FEB 22 1982
S
A

Approved for public release; distribution unlimited.

DESIGN, FABRICATION AND INSTRUMENTATION
OF AN
ANNULAR DIFFUSER RESEARCH FACILITY

THESIS

Presented to the Faculty of the School of Engineering
of the Air Force Institute of Technology
Air Training Command
in Partial Fulfillment of the
Requirements for the Degree of
Master of Science

by

Richard M. Moore, B.S.

Capt USAF

Graduate Aeronautical Engineering

December 1982

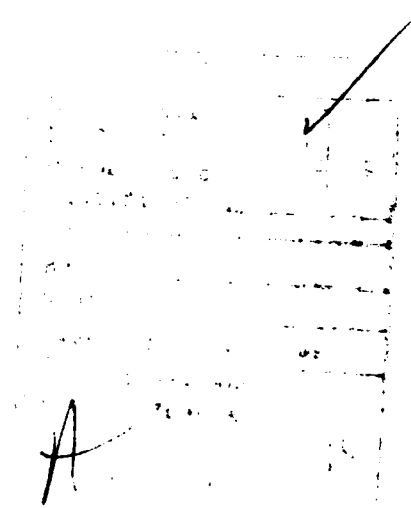

Approved for public release; distribution unlimited.

Acknowledgements

The design, fabrication and instrumentation of the Annular Diffuser Research Facility has been a sizeable undertaking, however, it was by no means solely the product of one man's efforts. First of all I thank my God who "has supplied all my needs according to His riches in glory in Christ Jesus." My wife, Jeannie, and my son, Christopher, deserve my deepest gratitude for their love, support, and patience during my AFIT assignment. I thank Dr William Elrod, my advisor, for his technical assistance and his constant willingness to lend a helping hand. Dr Harold Wright and Captain Wesley Cox provided valuable suggestions as thesis committee members. The sponsor of this project, the Air Force Wright Aeronautical Laboratories, AFWAL/POTC, provided indispensable financial assistance and computer support. My special thanks to Mr Dale Hudson for his help in arranging this support. Mr Al Lightman of the University of Dayton, Mr Cliff Weismann of the Air Force Wright Aeronautical Laboratories and the engineering staff of TSI Incorporated all improved my understanding of LDV theory and techniques. Mr John Brohas did an excellent job in his fabrication of the Facility stilling chamber. My thanks are also due to Mr Paul VonRichter of the University of Dayton who, as a favor, cut the test section optical windows. Lastly, I thank my lab partner, Captain Jim Lester, who shared in the high points and helped smooth out the tough times of the last 18 months with his words of encouragement.

Richard M. Moore

Contents

	<u>Page</u>
Acknowledgements	ii
List of Figures	iv
List of Symbols	v
Abstract	vi
I Introduction	1
Background	1
Objective	2
Overview	3
II Theory	4
Velocity Profile Development Predictions	4
Laser Doppler Velocimetry	5
III Apparatus and Instrumentation.	13
Flow Handling Apparatus	13
Instrumentation	21
IV Procedures	28
Facility Assembly and Checkout	28
Data Collection	29
Data Reduction	32
V Results	33
Data Collection and Analysis	33
Seeder Evaluation	40
Problems and Limitations	41
VI Conclusions	43
VII Recommendations	45
Bibliography	46
Appendix A: Representative LDV Data	47
Appendix B: LDV Dimensions	51

List of Figures

<u>Figure</u>	<u>Page</u>
1 Measuring Volume	7
2 Measuring Volume Fringes	7
3 Doppler Signal	9
4 Gaussian Distribution of Light Intensity	9
5 Annular Diffuser Research Facility Configuration	14
6 Stilling Chamber	16
7 Configuration of Test Sections	19
8 Optical Windows	22
9 Window Effects on Test Section Wall Contour.	22
10 Laser Light Paths Through LDV Optics Train	24
11 Masked LDV Receiver Optics	30
12 Locations of Data Collection Stations	30
13 Velocity Profile at Station # 1	34
14 Velocity Profile at Station # 2	35
15 Velocity Profile at Station # 3	36
16 Velocity Profile at Station # 4	37
17 LDV Data Repeatability: Station # 1	38

List of Symbols

C_w	flow channel width in the radial direction	mm
D_e	laser beam diameter	mm
d_f	fringe spacing	μm
d_m	measuring volume diameter	μm
f	frequency	Hz
f_l	focal length	mm
G	mean mass flux	$\text{lbm}/\text{ft}^2\text{-sec}$
HP	Hewlett Packard	
IGV	inlet guide vane	
K	half angle of laser beam intersection	deg
LDV	laser doppler velocimeter	
l_m	measuring volume length	μm
M	Mach number	
\dot{m}	mass flow rate	lbm/sec
N	number of electrical pulses	
N_f	number of fringes in measuring volume	
N_p	particle density in the main flow	$\text{particles}/\text{cm}^3$
N_s	particle density in seeder output	$\text{particles}/\text{cm}^3$
Re_x	Reynold's number based on X	
SNR	signal to noise ratio	
V	average velocity	ft/sec
V_∞	fluid velocity outside the boundary layer	ft/sec
X	Axial position	ft
x	axial distance behind the trailing edges of the inlet guide vanes	cm
δ	boundary layer thickness	in.
λ	wavelength	nm
μ	dynamic viscosity	$\text{lbf-sec}/\text{ft}^2$
ν	kinematic viscosity	ft^2/sec

Abstract

Annular diffuser and annular diffuser inlet velocity profile data is required to verify theoretical annular diffuser velocity profile prediction techniques. This document records the advancements made during the second phase of an effort to fabricate and instrument an Annular Diffuser Research Facility. A laser doppler velocimeter, which is the primary component of instrumentation, was assembled and proper operation was verified. A stilling chamber was fabricated to provide uniform, non-separated flow at the entrance to the preexisting annular test section components. Velocity profile data was collected and analyzed and repeatability was demonstrated at four axial stations within the annular diffuser and annular diffuser inlet test sections. Turbulence intensity data is not available at this time.

DESIGN, FABRICATION AND INSTRUMENTATION
OF AN
ANNULAR DIFFUSER RESEARCH FACILITY

I Introduction

This is the second phase of a program to design, fabricate and instrument a facility capable of collecting velocity profile data from annular diffusers of varying geometries and turbulence levels.

Background

Current turbojet and turbofan design practice calls for utilizing an annular diffuser between the engine compressor and combustor. This adapts the compressor discharge flow to the conditions that are appropriate for inlet to the combustor. Steady, non-separated flow through the diffuser and into the combustor is imperative since unsteady flow or uneven flow distribution will likely cause isolated areas of overheating in the engine combustor and turbine.

Extensive theoretical and experimental data is available for two dimensional diffusers (Ref 1). However, only very limited experimental data is available to verify annular diffuser theory. This research project is designed to provide a facility with the capability of collecting the necessary data on the velocity profiles in annular diffusers for various flow conditions.

The first phase of this research project was accomplished in 1981 by Kelley (Ref 2). Diffuser theory was researched and the Facility prototype test sections were fabricated. Air was supplied to the diffuser inlet through a segment of a conical diffuser. A traversing device was built which allowed accurate positioning within the test sections of pitot and hot-wire anemometer probes. These instrumentation systems were used to collect initial data on the diffuser performance. The hot-wire and pitot data revealed unsteady flow in the test sections. A laser doppler velocimeter (LDV) was chosen as the primary form of instrumentation due to its non-intrusive data collection capability. A LDV system was acquired and assembly of the optics train was initiated, however, no LDV data was collected.

Objective

The objective identified for the second phase of the Annular Diffuser Research Facility development is:

Collect representative velocity profile data in the annular inlet and annular diffuser test sections of the Annular Diffuser Research Facility using the laser doppler velocimeter. The data should be both accurate and repeatable.

This phase of the system design, fabrication and checkout is being accomplished at the Air Force Institute of Technology, Wright-Patterson AFB, Ohio. Final installation and checkout

of the system will be accomplished in a test cell which is capable of providing the required mass flow rates to produce diffuser inlet Mach numbers ranging from 0.2 to 0.6.

Overview

Documentation of the results of this investigation will include:

1) Theoretical concepts which went into the development of the Annular Diffuser Research Facility.

2) Detailed description of the experimental apparatus and the instrumentation which comprise the Annular Diffuser Research Facility.

3) Outline of the basic procedure used to set up the Annular Diffuser Research Facility and to collect representative velocity profile data.

4) Results of this year's effort.

5) Conclusions and recommendations which resulted from the study.

II Theory

This section will briefly define and discuss prediction techniques for velocity profile development and the theory and capabilities of a LDV system. For a discussion of diffuser history and theory see references 1 and 2.

Velocity Profile Development Predictions

Fluid flow within a boundary layer can be either laminar or turbulent. The Reynold's number, Re_x , is commonly used to predict whether a boundary layer will be laminar or turbulent.

$$Re_x = (X V_\infty) / \nu \quad (1)$$

In equation (1), X is the distance from the leading edge of the surface over which the fluid is flowing to the point being studied, V_∞ is the velocity of the fluid outside the boundary layer, and ν is the kinematic viscosity of the fluid. For a smooth, flat plate, boundary layer transition will normally occur between Reynold's numbers of 1×10^5 and 3×10^6 (Ref 12:270). Transition Reynold's numbers will be similar for surfaces which differ slightly from flat plate geometries. If the flow outside the boundary layer is turbulent or if the surface which the fluid is flowing over is rough, transition will occur at the lower end of this range of Reynold's numbers.

The thickness of a turbulent boundary layer, δ , on each wall of an annular flow channel can be estimated using flat

plate turbulent boundary layer theory as described by equation (2) (Ref 3:175):

$$\delta = .371 (\mu/G)^{.2} X^{.8} \quad (2)$$

where the mean mass velocity, G , is the mass flow rate of the fluid divided by the cross sectional area of the flow channel, and μ is the dynamic viscosity of the fluid.

In an annular passage the boundary layer on the inner wall is normally thinner than the boundary layer on the outer wall. This occurs because the shear work transmitted to the flow by the inner wall is being diffused to an expanding flow area while the opposite is true for the outer wall. Therefore, the boundary layer thickness on the inner wall will be thinner than the value given by equation (2) while δ for the outer wall will be greater than the calculated flat plate value (Ref 3:99). The smaller the ratio of the inner wall radius to the outer wall radius, the more pronounced this effect will be. The sum of these two thicknesses will be approximately twice the calculated boundary layer thickness.

Laser Doppler Velocimetry

Laser doppler velocimetry is a technique used to measure the instantaneous velocity of liquid or gaseous fluid flows. One, two or three components of the velocity can be measured. One of the most common LDV techniques uses two equal intensity, single wavelength, coherent beams of laser light for each velocity component. These beams are crossed at a

point in the flow field. The effect of crossing a pair of coherent laser beams can be explained using the wave theory of light. When two waves of coherent light intersect they interfere with each other (Ref 4:23-28, 5:435). If the intersection takes place at a location where the waves of both beams are at their crest constructive interference occurs and a bright fringe is formed. Where one wave is in a trough and another is at its crest destructive interference occurs and a dark fringe is formed. Thus, parallel planes of alternating dark and light fringes are formed throughout the space where the two beams intersect (Ref 6, 7:97). This space, which is called the measuring volume, is depicted in Figure 1. Figure 2 is a photograph of fringes formed in a LDV measuring volume.

When a particle suspended in the flow travels through the measuring volume with a component of its velocity perpendicular to these fringes it will intersect both light and dark fringes. As it crosses a light fringe it will scatter light in all directions. No light will be scattered from a dark fringe. The result is a periodic series of light bursts which form a doppler signal (Ref 13). The frequency of the bursts of light is proportional to the particle component of velocity which is perpendicular to the fringes. The burst frequency is calculated by dividing a specified number of bursts by the time interval required for that number of bursts to occur. Multiplying the fringe spacing by the burst frequency reveals the component of the particle (and therefore the flow)

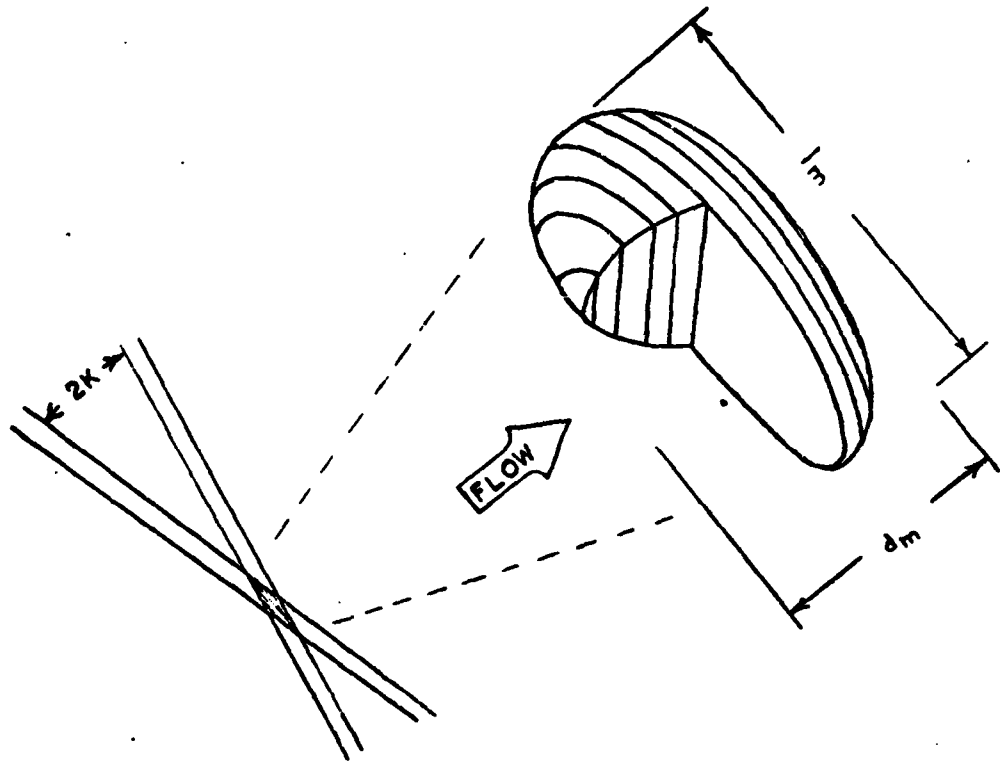

FIGURE 1. MEASURING VOLUME

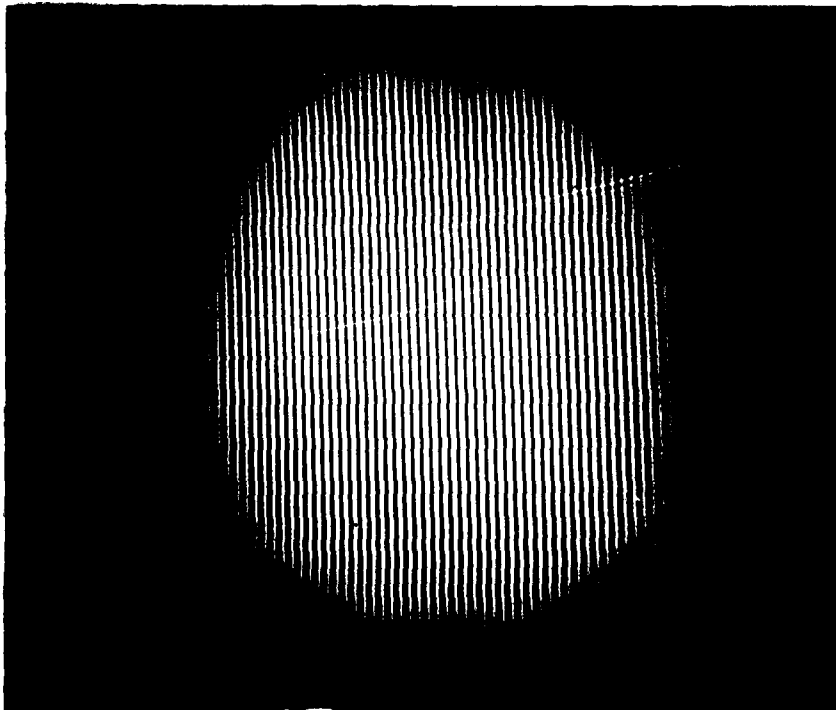

FIGURE 2. MEASURING VOLUME FRINGES

velocity perpendicular to the fringes. Figure 3 is a picture of an oscilloscope trace of the signal made by a particle traveling through an LDV measuring volume.

The dimensions of the measuring volume are calculated quite simply if a few specifics are known about the particular LDV system in use and one approximation is accepted. The light intensity of a properly focused beam should vary radially in a Gaussian distribution (Ref 4:16) (see Figure 4). Theoretically a laser beam has infinite width, however, the intensity of the beam drops off very rapidly in the radial direction. Therefore, the radius of the beam is normally approximated by the distance away from the beam centerline where the light intensity is e^{-2} times the centerline intensity. This same e^{-2} approximation is used to define the edges of the measuring volume (see Figure 1). Equations (3) and (4) describe the diameter, d_m , and the length, l_m , of the measuring volume:

$$d_m = (4 f l \lambda) / (\pi D_e) \quad (3)$$

$$l_m = d_m / \tan K \quad (4)$$

Where $f l$ is the focal length of the transmitting lens, D_e is the diameter of the beam at the point where it enters the transmitting lens, λ is the wavelength of the laser light, and K is the half angle between the laser beams. The fringe

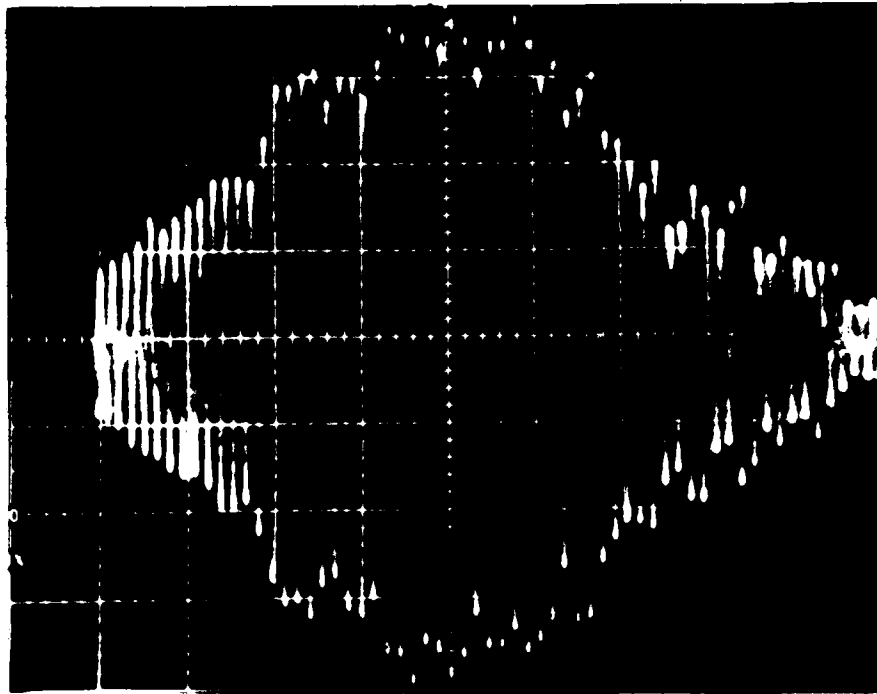

FIGURE 3. DOPPLER SIGNAL.

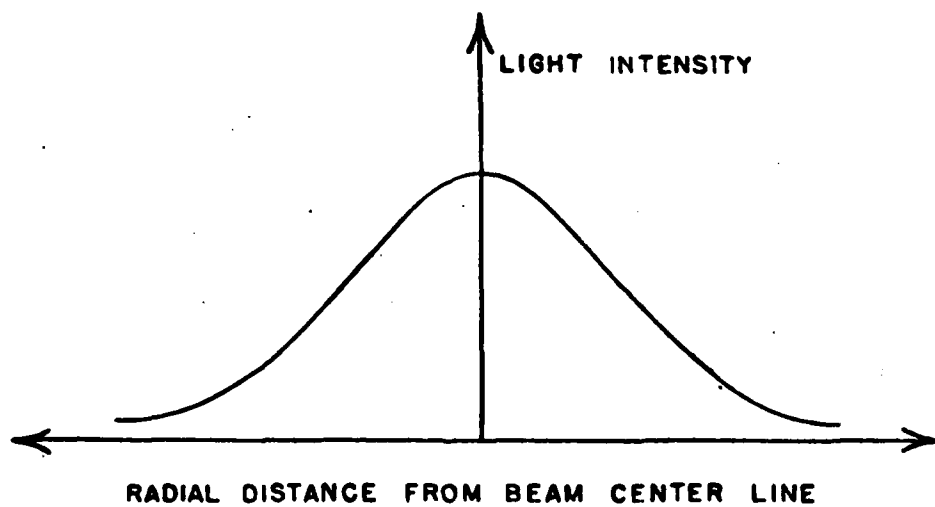

FIGURE 4. GAUSSIAN DISTRIBUTION OF LIGHT INTENSITY.

spacing, d_f , is calculated using equation (5):

$$d_f = \lambda / (2 \sin K) \quad (5)$$

Equation (6) is used to determine the number of fringes, N_f , in the measuring volume:

$$N_f = d_m / d_f \quad (6)$$

The size, shape and composition of the particles moving through the measuring volume significantly affect the signal quality and the accuracy of the data. Particles which are large scatter large amounts of light. However, they do not always move precisely with the turbulent eddies in the flow due to their high ratio of momentum to aerodynamic drag. Small particles move well with the flow but they scatter much less light. If the diameter of a particle is an integer multiple of the fringe spacing, d_f , that particle will scatter a nearly constant amount of light as it moves through the measuring volume. In other words half of its projected surface area is always being illuminated with bright fringes while the other half is always in dark fringes. Therefore, no signal is created. The best particle size depends upon the application, however, particles with a diameter around $.7d_f$ or $1.7d_f$ normally provide good data in gaseous flows (Ref 6:SE-17A).

Flows can be seeded with solid particles or liquid droplets. Solid metal particles are required for high

temperature flow studies while small commercially manufactured latex spheres are excellent solid monodisperse (uniform diameter) particles. Liquids are the least expensive form of seeding material. Water, water based liquids and oils are commonly used. When any form of non-water soluble liquid is used the seeded flow must not be breathed since the human body can not clear these liquids from the lungs. Breathing significant amounts of oil vapor can result in an incurable form of pneumonia.

The rate at which seed is introduced into the flow directly affects the data collection rate. Multiple particles in the measuring volume at one time can produce erroneous data, indicating higher than actual velocities. Introducing very few particles into the flow tends to produce data at a tediously slow rate. Normally one particle in the measuring volume at a time produces accurate data at a high rate. The particle density in the flow being studied, N_p , is calculated using equation (7):

$$N_p = N_s (Q_s / Q_t) \quad (7)$$

where N_s is the particle density in the seeder output (particles/cm³); Q_s is the volume flow rate of the seeder output (cm³/sec) and Q_t is the volume flow rate of the entire flow. If Q_t is high seeding rates resulting in one particle in the measuring volume at any instant may not be attainable with commercially available seeders. The seeding rate

requirement can be reduced by one to two orders of magnitude if the seed is only introduced in that portion of the flow which may pass through the measuring volume.

Laser doppler velocimeters have several advantages as well as a few disadvantages. Primarily, a LDV can determine instantaneous flow velocity components without intruding into the flow with a disruptive probe. A LDV can often be used where a probe could not be placed such as between the rotor blades in a turbine. LDV systems measure velocity independent of the flowing fluid temperature and density. In addition, no calibration is necessary with an LDV.

The relatively high cost of an LDV makes pitot probes and hot-wire anemometers a logical alternative where the disruption caused by the insertion of a probe into the flow is acceptable. The need for particulate matter in the flow is a LDV requirement which is not shared by the pitot or hot-wire systems.

The finite size of the measuring volume and reflections off nearby surfaces make it difficult to collect data very near walls or near wind tunnel models in a test section. However, probes are commonly more restricted in their use near these surfaces than the LDV.

III Apparatus and Instrumentation

The Annular Diffuser Research Facility consists of both flow handling apparatus and data collection instrumentation. The entire Facility is depicted in Figure 5.

Flow Handling Apparatus

The flow handling apparatus consists of eight major components: the air supply, stilling chamber, seeding hardware, interface annulus, inlet guide vane section, annular inlet test section, annular diffuser test section, and the diffuser dump section. The last four components listed were fabricated during the first phase of the Facility development. The main characteristics of these four components are summarized herein; extensive detail on them is contained in reference (2).

Air Supply. During the fabrication and checkout phase of this project air is being supplied to the stilling chamber by two Worthington Corporation compressors capable of supplying approximately one pound mass of air per second. This flow rate will allow average velocities of up to 31 feet per second in the annular inlet test section. The air flows from the compressors to the stilling chamber through a three inch pipe.

Stilling Chamber. The pressure and velocity of the air are reduced immediately upon entering the stilling chamber. Next the flow is smoothed, seed is added, and the air/seed mixture is reaccelerated through an annular nozzle prior to entering the annular interface. A cut-away view of the

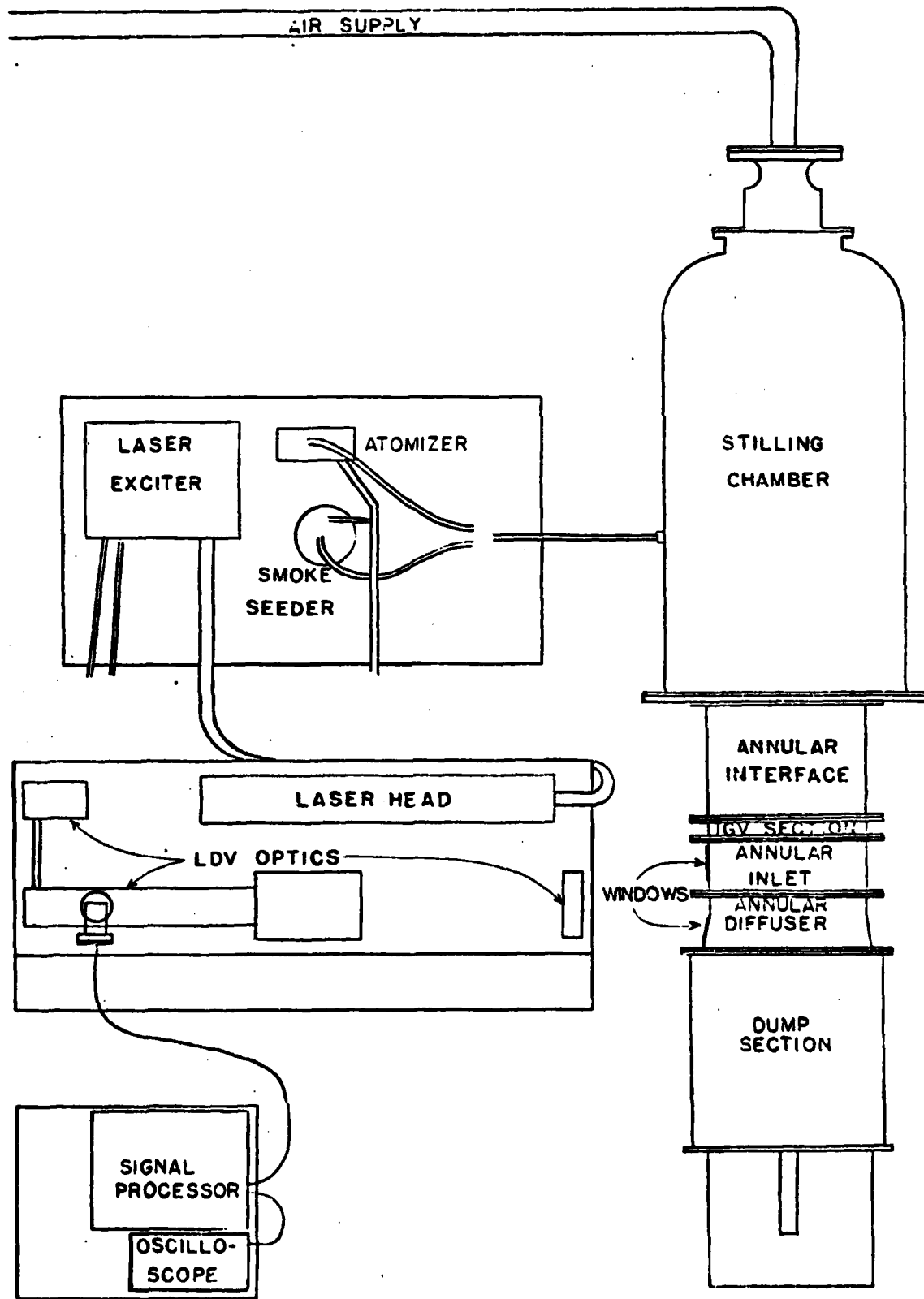

FIGURE 5. ANNULAR DIFFUSER RESEARCH FACILITY CONFIGURATION

stilling chamber is shown in Figure 6. The bell shaped stilling chamber is made of $\frac{1}{4}$ inch thick steel with one inch thick plywood covering the outer portion of the bell mouth.

The perforated cylinder at the entrance to the stilling chamber serves to smooth the flow and reduce the pressure from 50 pounds per square inch to 14.7 pounds per square inch. This cylinder is made from $\frac{1}{8}$ inch thick sheet steel. Eighty one, $\frac{1}{8}$ inch diameter holes have been drilled in the cylindrical wall in order to allow air to flow into the low pressure section of the chamber. The required number and diameter of holes were calculated using a method outlined by Rothbart (Ref 8:37.10-37.12). Obviously additional holes will be required when higher test section velocities are studied. The pressure is reduced at each orifice as the fluid is accelerated to the speed of sound in the orifice and then travels through a series of alternating expansion and shock waves which stand at the exit of each orifice. Air exits the holes in the radial direction then mixes and diffuses naturally to approximately two feet per second as it turns to the axial direction.

Between the perforated cylinder and the nozzle the flow travels through four parallel panels of window screen mounted one inch apart. The screens are 14 mesh and are composed of 69 gauge steel wire. In addition to reducing any distortion of the flow across their face, the screens introduce an even distribution of low intensity turbulence into the air flow.

Immediately downstream of the screens, in the region where the velocity of the air is still approximately two feet per second, the seed is injected into the flow. A $\frac{3}{8}$ inch

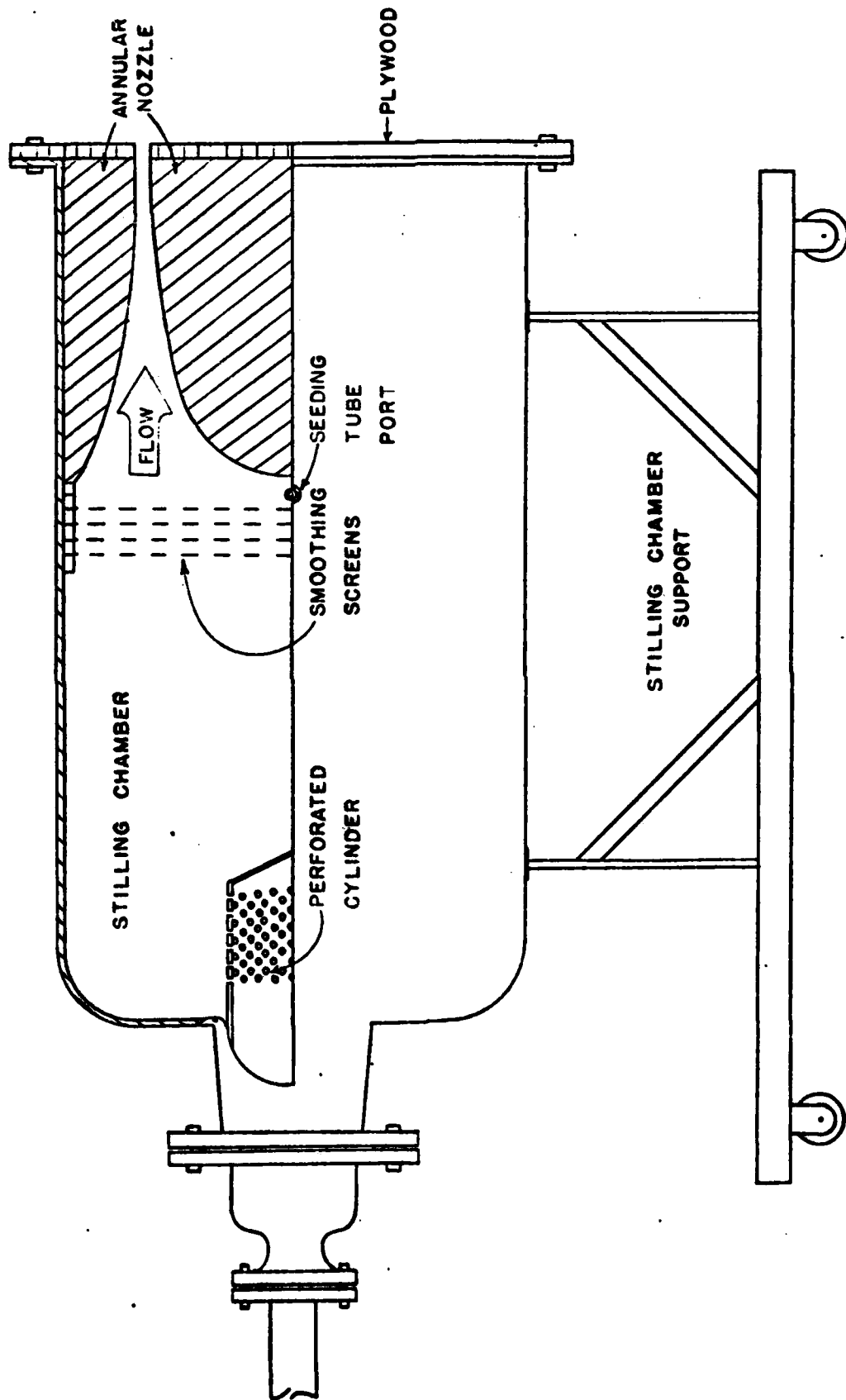

FIGURE 6 STILLING CHAMBER

diameter stainless steel tube protruding through the sidewall of the stilling chamber carries the seed into the chamber. The particulate matter is injected into the flow through two 1/4 inch diameter tubes which are welded onto the main tube. The main seed tube can be rotated about its axis and can be moved horizontally, in and out of the chamber, to allow the operator to optimize the seed placement.

Once the seed has been introduced, the flow is accelerated through an annular nozzle. Wind tunnel theory as described by Larson (Ref 9) was used to design the annular nozzle. The outer body of the nozzle is made of laminated wood. It rests on a thin metal saddle situated along the lower wall of the stilling chamber. The position of the saddle and, therefore, the nozzle outer body can be adjusted slightly. The center body of the nozzle is composed of styrofoam with a smooth surface applied.

Seeding Hardware. Two particle generators were used to seed the air flow. The first was designed and manufactured at AFIT. It consists of a regulated air supply, a large glass jar, a small section of window screen, a section of flexible tygon hose, and several small pipe fittings. Regulated air was injected into the the jar through a 90° elbow which caused the air to swirl. Two burning cigarettes were placed on the piece of molded window screen near the bottom of the jar in a position which would allow maximum exposure to the swirling air. Smoke filled air was then allowed to escape through the tygon hose and into the seeding tube.

The second particle generator is a TSI Incorporated model 9306 six jet atomizer. This device has an adjustable pressure

regulator and three control levers which allow the user to select appropriate seeding rates. This seeder is capable of atomizing most liquids. In addition it can produce solid particles from a salt solution or from a solution of latex spheres suspended in water. In order to produce these solid particles the water is evaporated from each particle after the atomization takes place. The seed from both of these particle generators is polydisperse (particles vary in size) but usually ranges from .5 μm to 3.0 μm in diameter.

Annular Interface. An interface connects the stilling chamber to the test sections. This annular interface is formed from two coaxially mounted metal cylinders. The inner and outer cylinders have radii of 9 inches and 10 inches respectively. Therefore, the cross-sectional area of the flow channel is 59.7 square inches (.4145 square feet).

Inlet Guide Vane Section. The smallest single component of the flow handling apparatus is the inlet guide vane (IGV) section. This is a 1½ inch long annulus section made up of two coaxial cylinders. Flanges around the outer cylinder provide support and allow the IGV section to be connected to the adjacent components. Sixty six equally spaced NACA 0012 airfoils are mounted radially between the inner and outer walls of the IGV section. These airfoils which are ¾ inches long can be adjusted simultaneously to a prescribed angle from -10° to +10° from the axial flow direction. The vanes provide the capability of studying the effects of swirl on the diffuser performance.

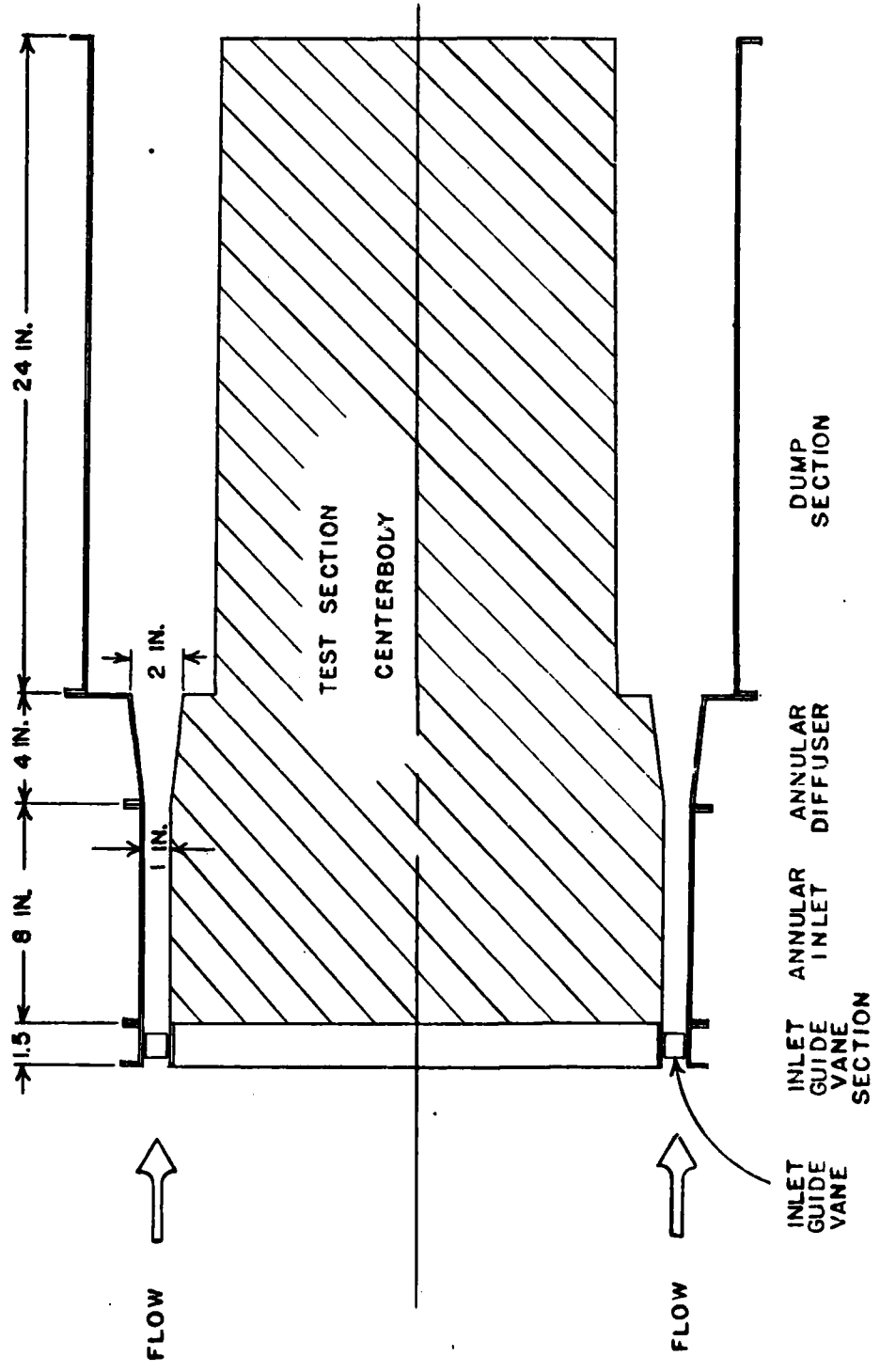

FIGURE 7. CONFIGURATION OF TEST SECTIONS.

Annular Inlet Test Section. In order to study the flow characteristics just upstream of the annular diffuser an eight inch long, constant area annular inlet test section was designed. The outer wall is a plexiglass cylinder supported by plexiglass flanges. The inner wall is formed by the front section of a wooden center body which is painted flat black. The entire center body which also forms the inner walls of the diffuser and dump sections is three feet long. An optical window was mounted in the outer wall of the test section. The design of this window will be discussed later.

Annular Diffuser Test Section. The four inch long annular diffuser is the main test section. The flow diffusion is accomplished by turning the inner wall in 7.1 degrees and the outer wall out by the same angle. The diffuser exit area is 119.4 square inches giving the diffuser an exit to inlet area ratio of 2.0. A second optical window was installed in this test section. The diffuser outer wall and the test section center body are designed to be removed and replaced by components which differ in geometry. This allows the same facility to be used to test a variety of annular diffuser area ratios and turning angles.

Diffuser Dump Section. After exiting the diffuser the flow enters the dump section. This portion of the flow channel is used to minimize the effects of disturbances in the laboratory on the flow in the test sections.

Optical Windows. Two optical windows were cut from high quality optical glass. The annular inlet test section window

is four inches long while the diffuser test section window is three inches long. The windows were limited to these lengths by the location of the flanges which hold the sections together. The inner face of each window was cut 3/4 inches wide in order to allow sufficient scattered laser light to return to the LDV collection optics while still producing minimal boundary layer disturbance in the test sections. Figure 9 shows the effect of replacing a 3/4 inch section of the 20 inch diameter annulus outer wall with a 3/4 inch wide optical window. The maximum change in flow channel width is .0035 inches.

Instrumentation

The Annular Diffuser Research Facility utilizes several instrumentation systems. The primary instrumentation system is a laser doppler velocimeter. Supporting systems include an oscilloscope, a pressure gage, a pitot tube, a water manometer and a mini-computer.

Laser Doppler Velocimeter. The LDV system is comprised of three basic components:

- 1) A Spectra Physics model 165-08 argon-ion laser.
- 2) A TSI Incorporated 9100-6 series single channel high power LDV sending and receiving optics train.
- 3) A TSI Incorporated model 1980 counter type signal processor.

The argon-ion laser is capable of emitting visible light in several distinct wavelengths varying from 459.9nm to 514.5nm. For LDV operation the laser is normally operated at the 514.5nm wavelength. At this green light wavelength the

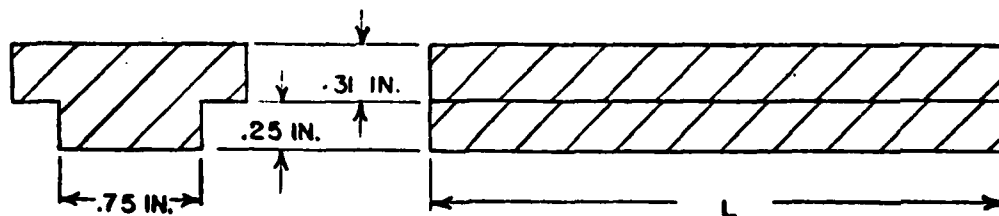

L = 4 IN. ANNULAR INLET TEST SECTION
 L = 3 IN. ANNULAR DIFFUSER TEST SECTION

FIGURE 8. OPTICAL WINDOWS

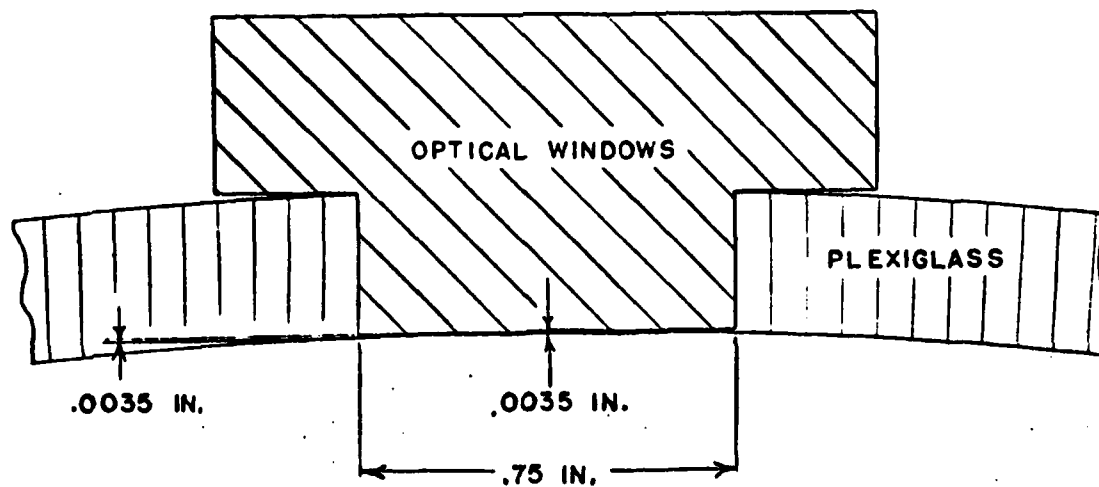

FIGURE 9. WINDOW EFFECTS ON TEST SECTION
 WALL CONTOUR.

model 165-08 laser is capable of emitting 1.7 watts of continuous power. The blue line, 488.0nm, is also commonly used. Water is passed through the cooling jacket of the laser plasma tube to carry away waste heat.

The light paths through the 9100-6 series optics train are depicted in Figure 10. After leaving the laser, the light beam is collimated in order to minimize beam divergence. The collimated beam is then turned 180° by a pair of mirrors which serve to shorten the required length of the LDV platform. The light is split into two parallel, equal power beams 50mm apart. This beam spacing is expanded to 131mm before the beams are turned and focused together to form the measuring volume.

A fraction of the light scattered by a particle passing through the measuring volume is collected by the same lens which focuses the beams together. This collected light is focused and transmitted through an aperture in order to cut out any light not originating at the measuring volume. It is then focused on the receiving spot of the photomultiplier tube where it is converted into an electrical signal. Both the laser and the optics train are mounted on a 108 pound mounting platform. Several of the laser doppler velocimeter optical and measuring volume dimensions are listed in Appendix B.

The electrical doppler signal produced by the photomultiplier tube is carried through a coaxial cable to the signal processor. Here a specified number of electrical pulses, N , are counted and timed. Using this information the signal processor calculates a doppler frequency and converts

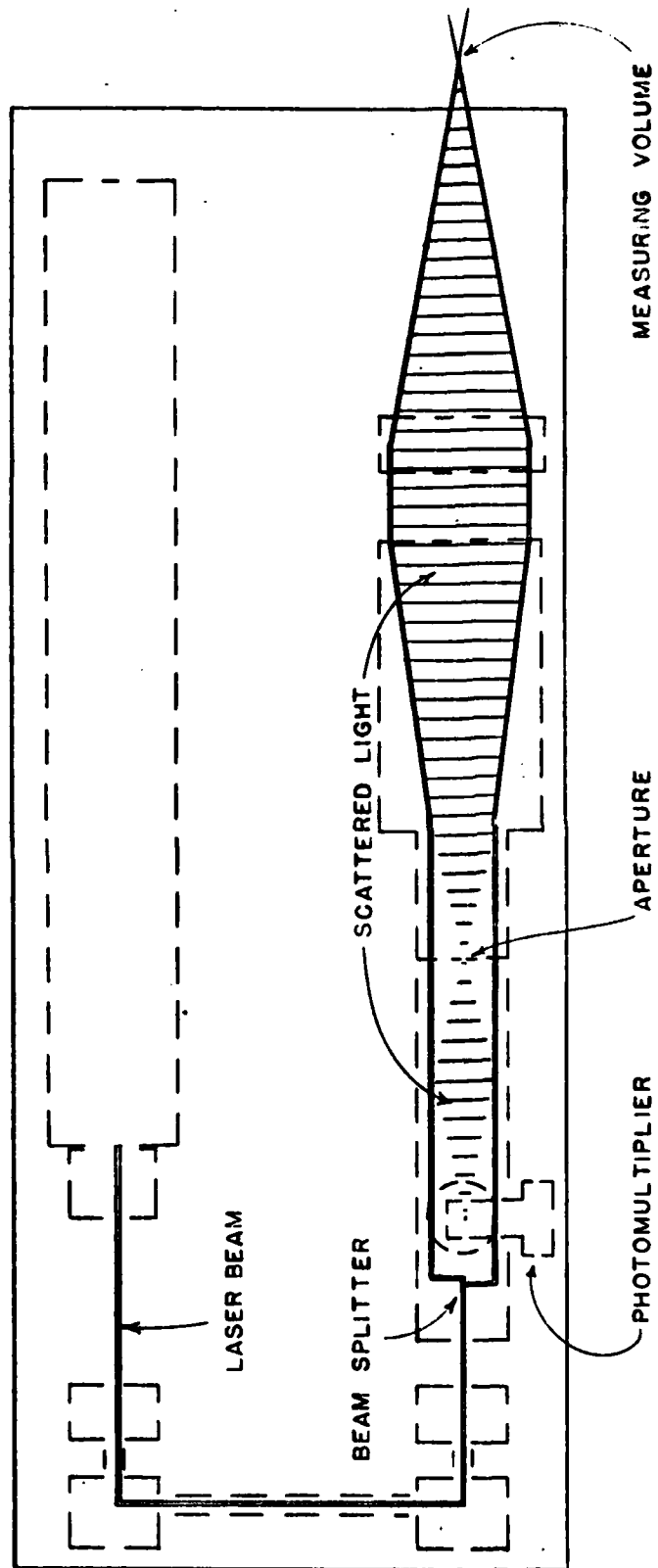

FIGURE 10. LASER LIGHT PATHS THROUGH LDV OPTICS TRAIN

the frequency into a D.C. voltage. A linear scaling factor is programmed into the processor by the LDV operator. This allows the voltage displayed to be numerically equal to the flow velocity in the operator's choice of units.

Several components built into the signal processor serve to remove noise from the signal. Adjustable high and low pass filters remove signals of any frequency not corresponding to the expected range of flow velocities. The amplitude limit filter cuts out any signal which is more powerful than an operator specified signal power level. This feature keeps the signal processor from using data generated by particles which are too large to follow the flow precisely. This filter is also used when data is being collected at the edge of a test section to eliminate some of the unwanted signals generated by light reflecting off walls or windows. Another component, the data validation circuitry, only allows signals to pass when a specified number of signal pulses, N , has approximately twice the time duration as the first half, $N/2$, of the pulses in that signal. If these two time measurements do not agree within an operator specified percentage the data point is rejected. For example, assuming the LDV operator sets the total number of signal pulses to 16 and the data validation circuitry rejection criteria to 7 percent. If the first 8 pulses of the signal are a total of 3 microseconds long then the entire 16 pulse signal must be between 5.58 microseconds and 6.42 microseconds long or the data point will be rejected.

Signal processor data can be transmitted through a digital output to a data acquisition system or it can be read directly from the signal processor's digital volt meter and digital data rate displays. When a data acquisition system is used instantaneous velocity data and turbulence intensity data can be collected accurately. In addition the computer associated with the data acquisition system can be used to reduce and analyze the data.

When the signal processor digital displays are used the effect of turbulence in the flow stream can be damped out by maintaining a reasonably high data rate and adjusting the digital voltmeter to respond slowly to fluctuations in the velocity data. This technique effectively averages the flow velocity. High data rates and low turbulence intensities provide the most accurate average velocity data. No practical method exists for collecting quantitative turbulence intensity data without a data acquisition system. A rough qualitative estimate can be made by setting the digital voltmeter to respond rapidly to velocity fluctuations and observing the range of flow velocities measured.

Oscilloscope. A Tektronix model 465M oscilloscope and a Ballantine 1066S oscilloscope were used interchangeably to monitor the filtered output of the signal processor. The filtered LDV data will produce obvious doppler bursts on either of these oscilloscopes.

Supply Line Pressure Gage. A pressure gage is mounted on the air supply pipe. The gage is used to measure the pressure

in the stilling chamber perforated cylinder where the flow is maintained essentially at stagnation conditions.

Pitot Tube. A pitot tube was used in conjunction with a water manometer during LDV system setup to validate LDV data.

Computer Resources. A Hewlett Packard HP-9845C mini-computer is used to analyze the LDV data. The results are plotted by the HP-9845C on a HP-9872B plotter.

IV Procedures

Once the laser doppler velocimeter had been incorporated into the Annular Diffuser Research Facility proper operation of the LDV had to be verified and data collection methodology had to be developed. Only after these tasks were accomplished could the objective of collecting representative LDV data be realized.

Facility Assembly and Checkout

Proper LDV operation was verified by using a cigarette smoke seeder to seed a free jet. LDV data was collected from the center of the free jet flow. Pitot tube pressure data from the same point in the free jet was used to verify the LDV velocity data.

Experimental LDV measurements were made with and without optical windows in the laser light pathway to determine the effect of the windows on the LDV performance. As expected, specular reflections off the window surfaces reduced the signal strength and, therefore, the data rate by 15 to 25 percent.

With all the components of the Annular Diffuser Research Facility assembled as depicted in Figure 5, experiments were carried out to develop methodology for optimizing the LDV signal to noise ratio, SNR. Noise problems were most acute while data was being collected very near the flow channel inner wall and near the optical windows. Maximum SNR's were obtained by operating the laser at output power levels around

½ watt while taking advantage of near maximum signal amplification at the photomultiplier tube and at the signal processor. The signal processor data validation circuitry was set to eliminate as much noise as possible. The high and low pass filters were set to bracket the expected frequencies and yet leave enough of a frequency band to permit any reasonable data points to pass.

Additional tests were run to determine what effect the 7.1 degree angle of the diffuser test section window would have on the LDV performance. A fraction of one of the laser beams was specularly reflected off the angled window and struck the receiving optics. Since this beam contained much more power than the light being scattered by particles moving through the measuring volume a very poor SNR was created at the diffuser test section. This problem was eliminated by placing a small mask in front of the receiving lens at the point where the splinter beam struck this lens as shown in Figure 11. This masking technique permitted the removal of 100% of the specularly reflected light beam while only reducing the collection of scattered light by approximately 4%.

Data Collection

Once basic data collection techniques were developed representative data was collected at two axial stations in each test section. Figure 12 shows the locations of each of these data collection stations. Average velocity data was collected at one millimeter increments across the flow channel at each station.

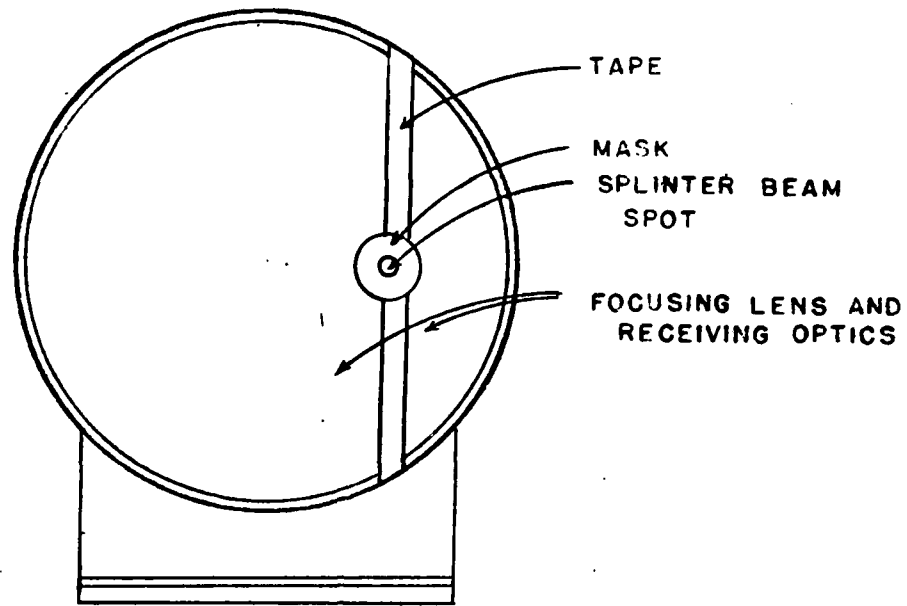

FIGURE II. MASKED LDV RECEIVER OPTICS

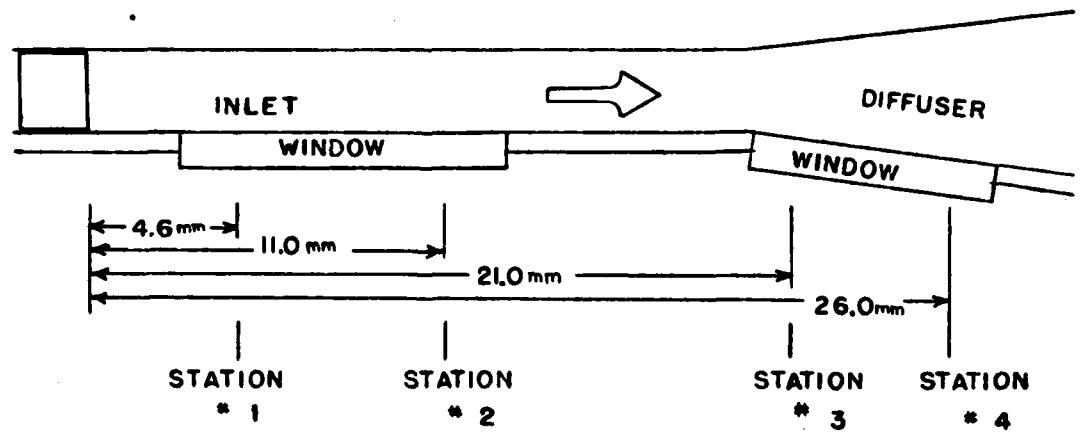

FIGURE 12. LOCATIONS OF DATA COLLECTION STATIONS

The LDV is aligned at each station by sliding the 300 pound LDV system and support table to a point where the LDV optics are aligned perpendicular to the axis of the flow handling apparatus and at the appropriate axial distance behind the inlet guide vanes. The measuring volume is translated across the flow by manually sliding the focusing lens toward or away from the test section. While this translation is less strenuous than moving the entire LDV platform, precise positioning of the lens can not be insured.

Several checks are made prior to recording a data point. First the data rate display is read to insure data is being collected at a reasonable rate. Data rates of greater than 500 per second are indicative of high frequency noise sources. Data rates of less than 0.2 per second will not allow the signal processor to "average" the data. If the data rate is low the seeder is checked for proper operation. Second, the oscilloscope is observed to check for the presence of doppler bursts which indicate good data points. Third, the operator observes the fluctuating velocity indications on the signal processor digital volt meter display. Approximately one minute of observation at each position is sufficient time for the operator to estimate the average axial velocity. If this value is near the expected velocity it is recorded. If the value differs greatly from the expected value the signal processor is adjusted in an attempt to eliminate any remaining noise.

Data Reduction

The HP 9845C mini-computer is used to calculate a second order least squares polynomial curve fit for the data at each axial station (Ref 11:817-819). The computer accomplishes a surface integration of the computed function to calculate the mass flow rates at each axial station. The calculated mass flow rates are compared to evaluate the quality of the data collected. The computer uses the HP 9872B plotter to graph the data and the calculated function. The graphs are used to insure that each set of data points define a reasonable velocity profile.

V Results

Once the Annular Diffuser Research Facility was assembled and data collection methodology had been developed representative average velocity data was collected and analyzed to evaluate the capability of the Facility.

Data Collection and Analysis

Representative data was collected at each of the four axial stations using the cigarette smoke seeder. Figures 13 through 16 are graphs of one set of data at each station. No quantitative determination can be made of the turbulence intensity, however, sufficient turbulence does exist to make the exact average velocity difficult to determine. Therefore, the accuracy of each data point is limited to plus or minus one foot per second (four percent of the flow channel centerline velocity). Data was collected at each station to within 1.5mm (.06in.) from each wall.

Data was collected at each of the stations on three occasions to study repeatability. The three velocity profiles determined at each station were compared. The high degree of correlation between each set of velocity profiles demonstrates the repeatability of the data. Figure 17 depicts all the data taken at station number one. Appendix A is a listing of all the data taken at each of the four stations.

The mass flow rates calculated for each station were compared. In every case the calculated mass flow rate was between 0.81 lbm/sec and 0.82 lbm/sec. This result verifies

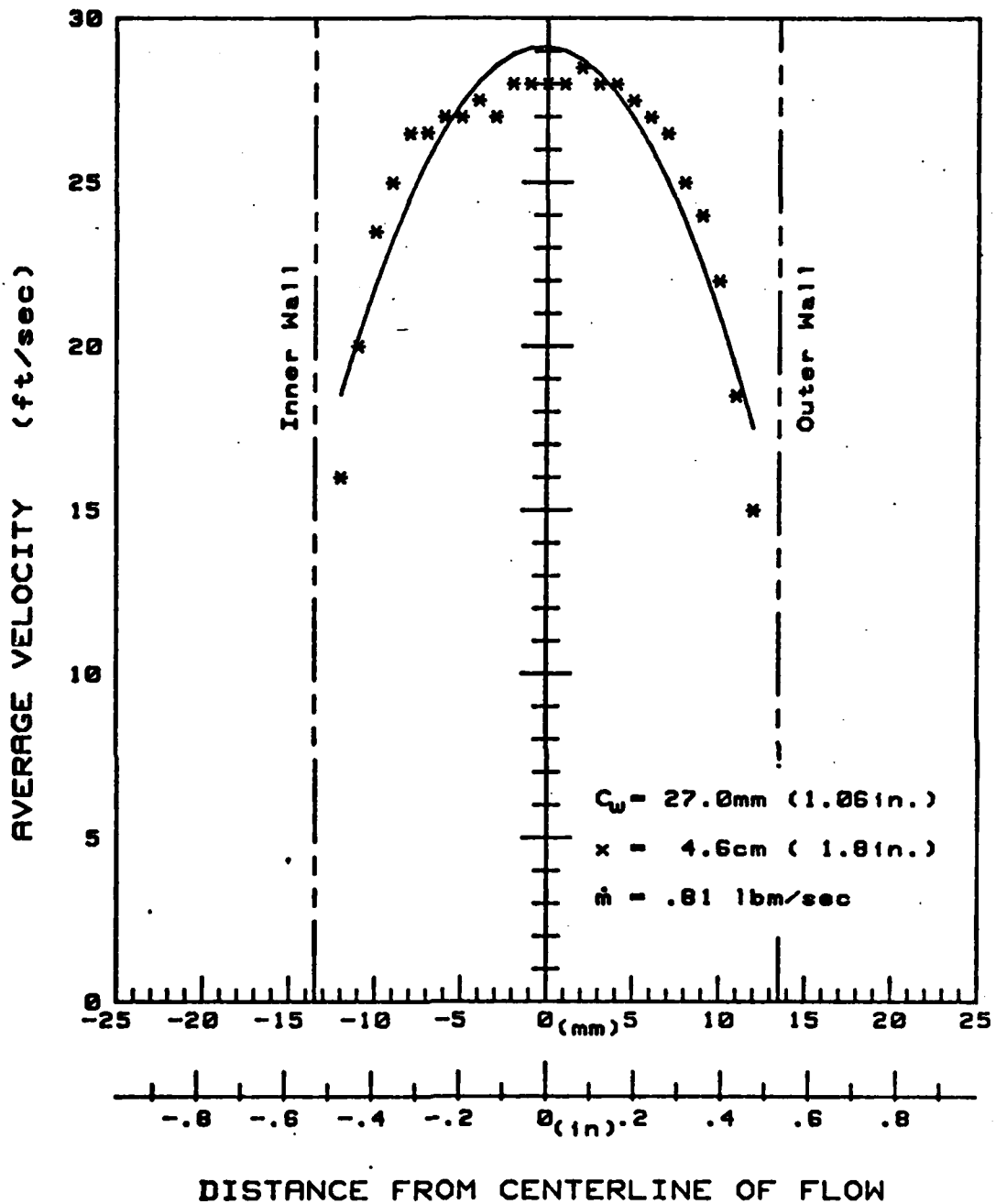

Figure 13. Velocity Profile at Station # 1

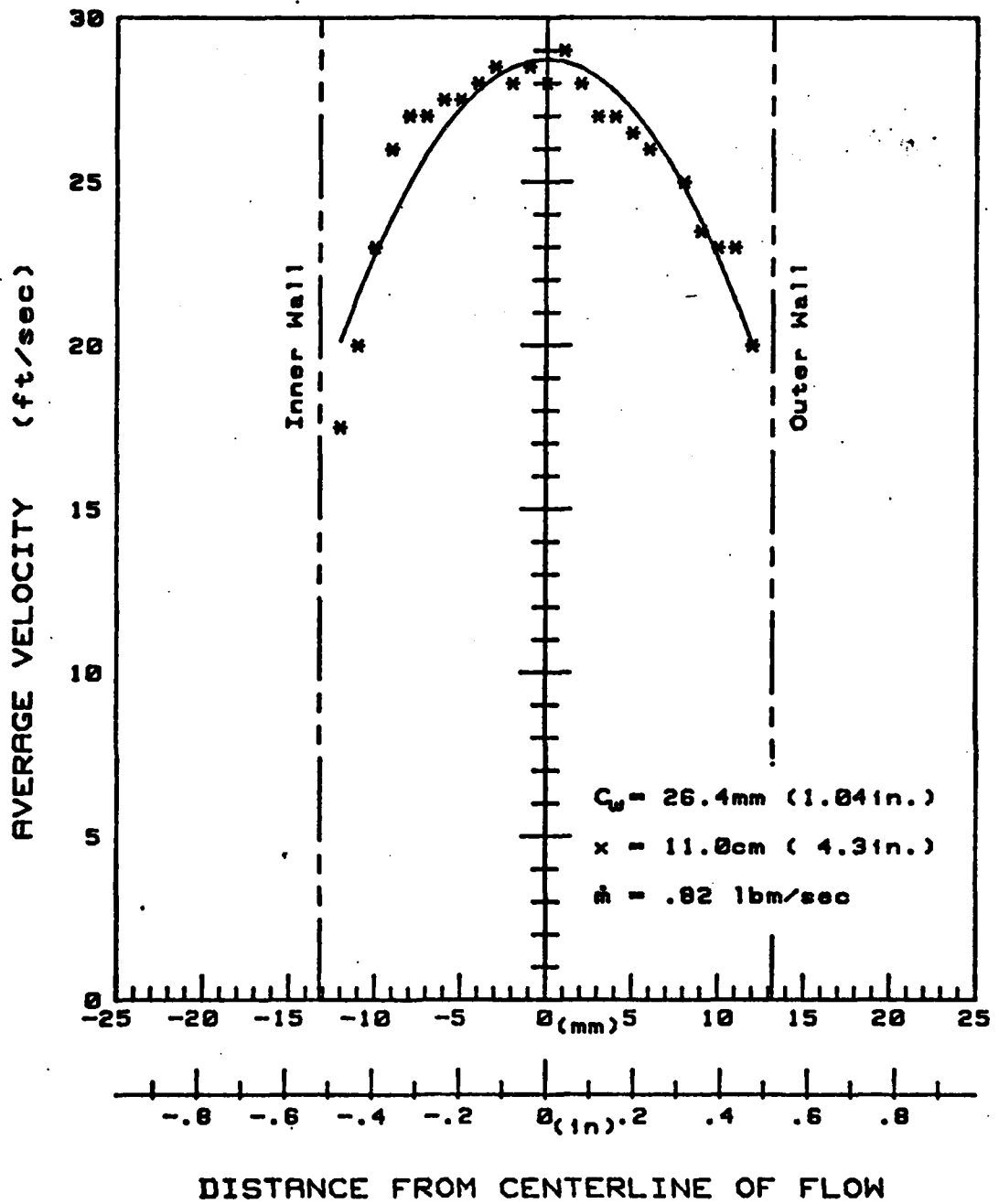

Figure 14. Velocity Profile at Station # 2

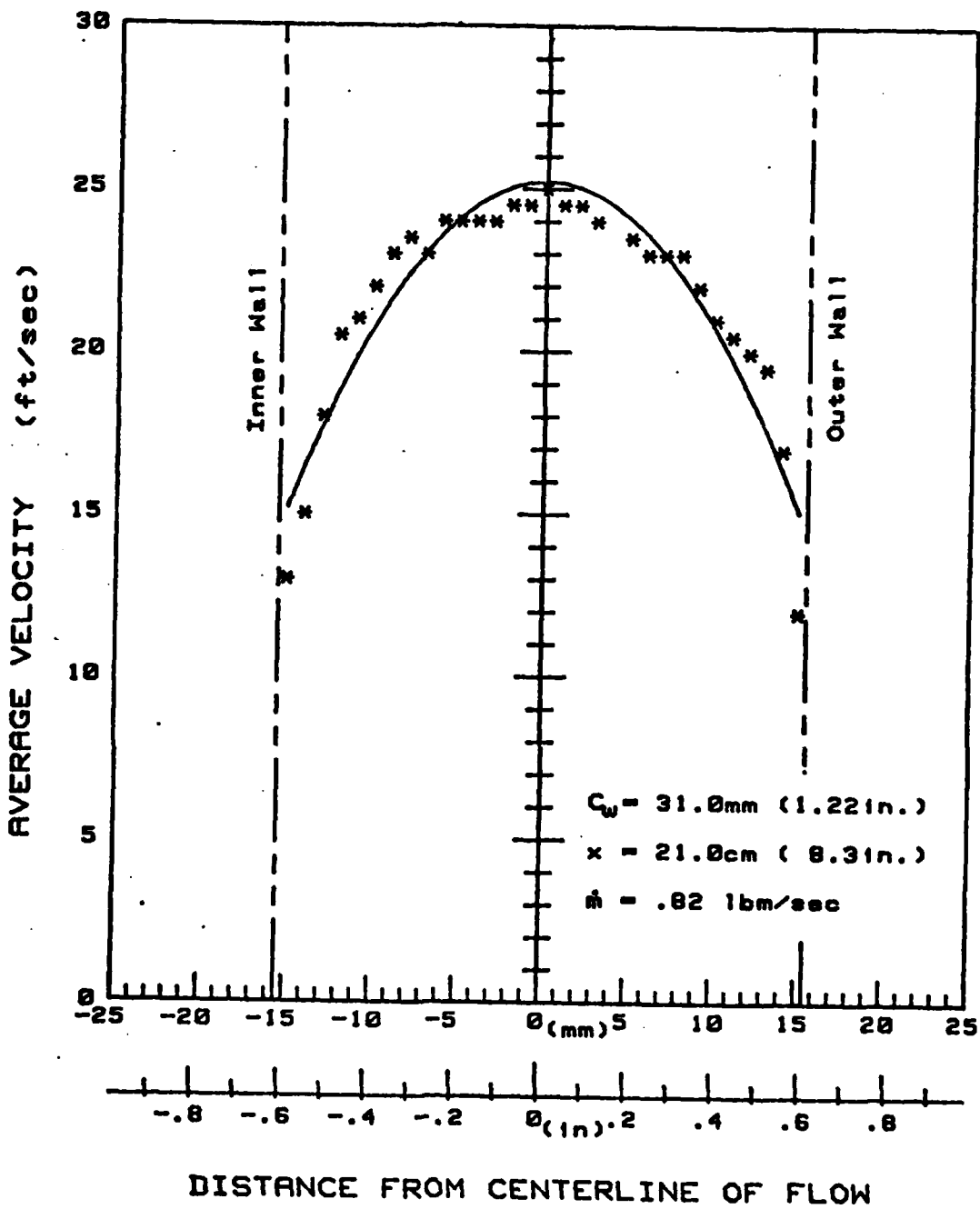

Figure 15. Velocity Profile at Station # 3

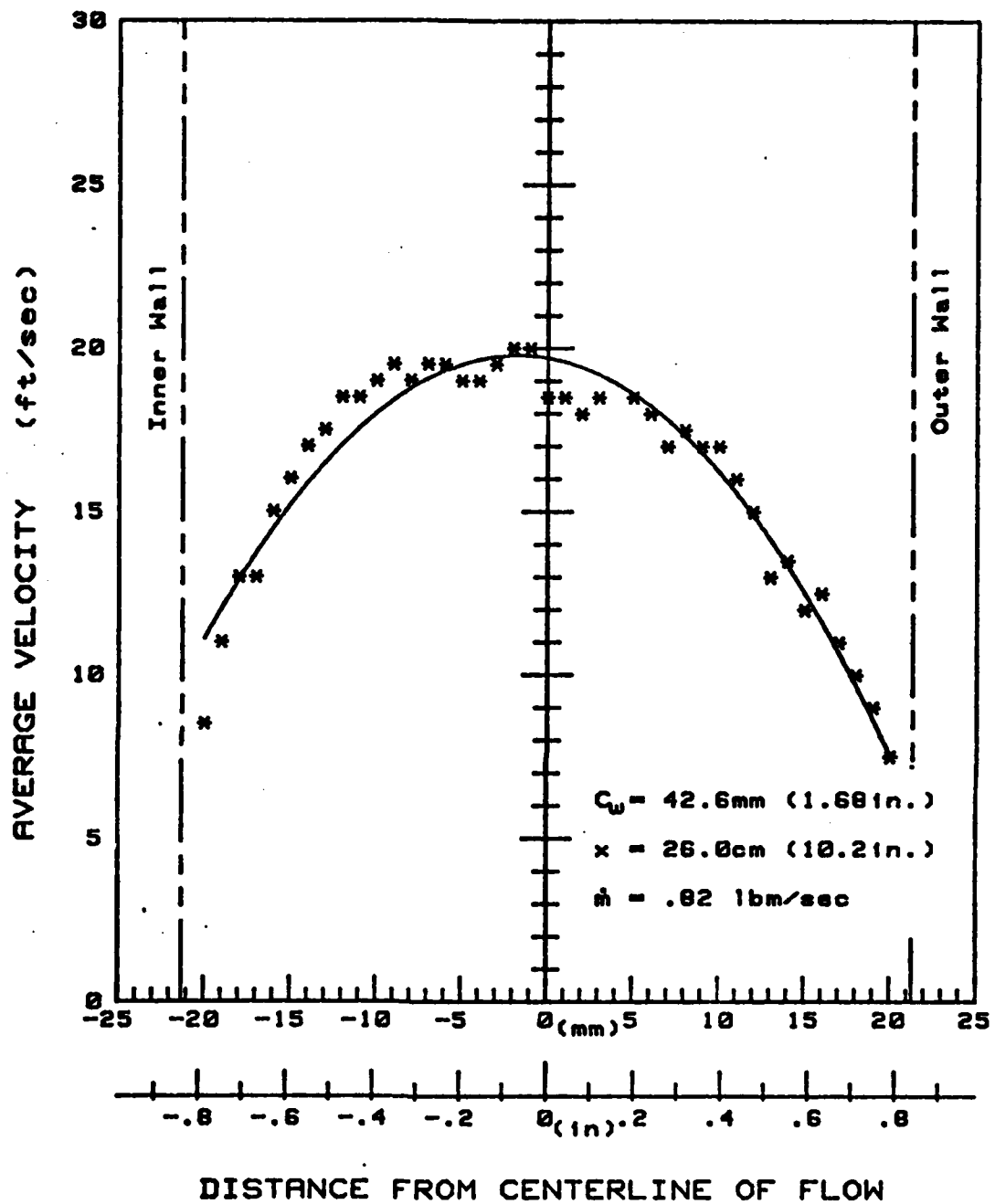

Figure 16. Velocity Profile at Station # 4

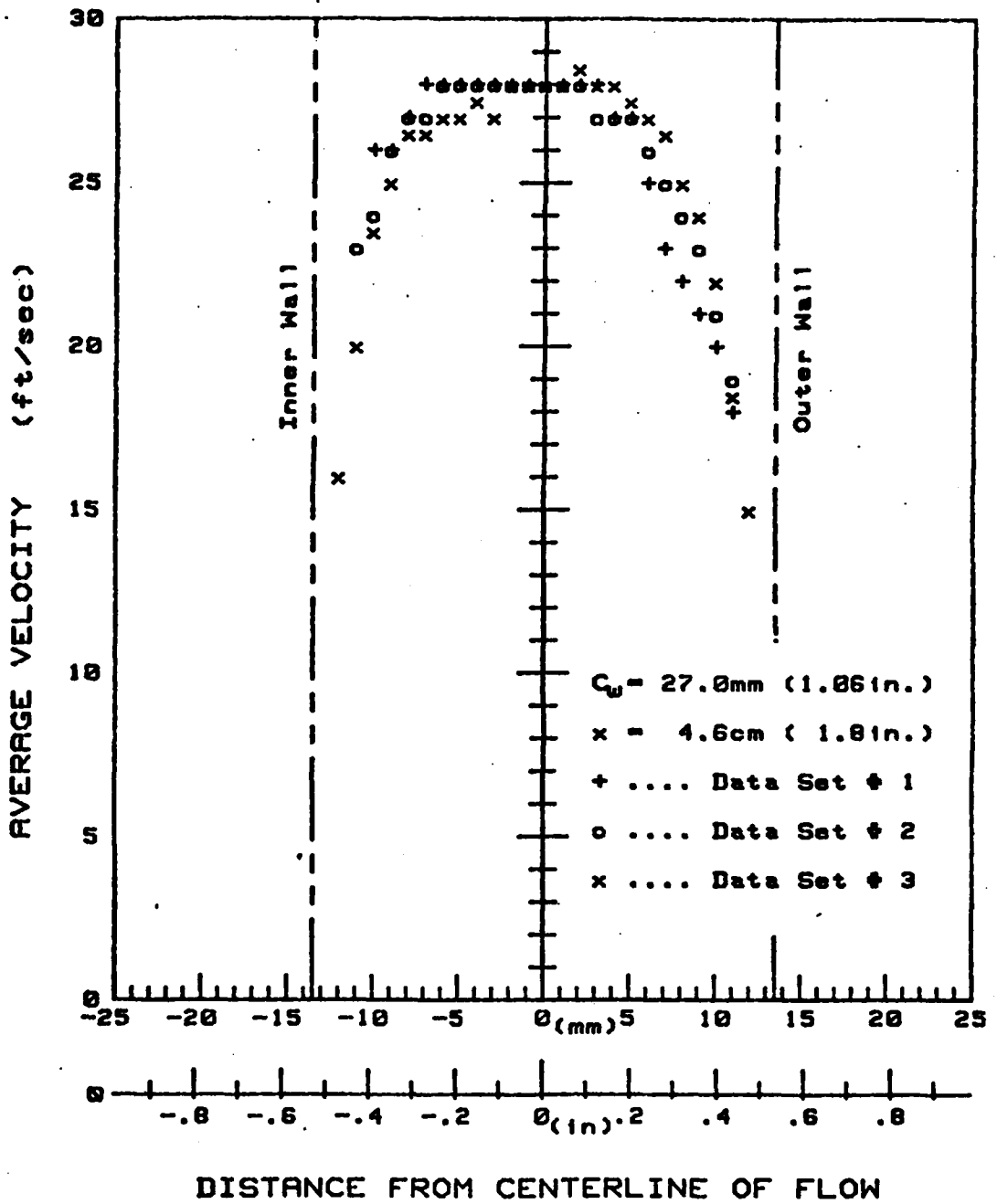

Figure 17. LDV Data Repeatability Example: Station # 1

the reliability of the data. By using a large number of data points the affect of a small error at any given data point is minimized. Therefore, the mass flow rates agree within a much smaller percentage margin of error than the individual data points.

The smooth tapering of the velocity near the walls at stations three and four demonstrates that the flow has not separated in the diffuser.

Calculations were carried out using flat plate boundary layer theory to model the flow through the annular flow channel. While the results of these calculations are only approximate, they do agree with the indications from the data. The Reynold's number in the test sections varies from 6.2×10^5 at station #1 to 7.7×10^5 at station #4. These Reynold's numbers are based on a free stream velocity of 31 feet per second and on the axial length of the flow channel from the leading edge of the annular nozzle to the data collection station in question. With these Reynold's numbers in the flow channel and with low level turbulence in the flow stream, the flow in the test section boundary layers should be turbulent. However, since these Reynold's numbers are in the range of transition Reynold's numbers, this prediction can not be stated with certainty without verification from the LDV data. This prediction was verified by the fluctuations in the velocity data indications on the signal processor display.

Calculations carried out using equation (2) predict boundary layer thicknesses on each wall of approximately 0.4 inches at station one. Therefore, the combined boundary

layers should span approximately 80% of the flow channel width at that station. Similar calculations predict 95% velocity profile development for the annular inlet just upstream of the diffuser. These predictions are verified by the data points plotted on Figures 13 and 14. These indications suggest that the profile is still developing between these two stations. Higher velocities will result in thinner boundary layers. As discussed previously the boundary layer on the inner wall of the annulus should be thinner than the one on the outer wall. Since the ratio of the inner wall radius to the outer wall radius is 0.9 this effect will be small, however, it is evident in Figures 13 through 16.

Seeder Evaluation

The cigarette smoke seeder provided good data, however, data rates varied significantly depending upon the number of cigarettes being burned and their position in the seeder. Data rates varied from one point every ten seconds to 150 points per second. Normally data rates ranged from one to four points per second. The seeder had to be "fed" two cigarettes every three to five minutes. Since the seeded air flow is exhausted into the room where the Facility is located, obvious health risks exist for any personnel in the room.

The TSI atomizer provided continuous, good quality data using glycerin as the seeding material. Data rates of one to five data points per second were common when the seeder was operated at its maximum seeding rate. Less than one ounce of glycerin was consumed per hour.

The signal processor data validation circuitry was set to accept only the highest quality data. Higher data rates are available from either seeder if the data validation circuitry rejection criteria is relaxed.

Problems and Limitations

Several problems and limitations were discovered while the Annular Diffuser Research Facility was being tested. The two primary limitations of the Facility are its inability to provide velocity data with less than a plus or minus one foot per second margin of error and its inability to provide turbulence intensity data. Each of these problems could be eliminated if a data acquisition system were incorporated into the Facility. TSI Incorporated markets a variety of data acquisition systems which can accomplish the necessary functions. The least expensive of these systems, the model 6200, is built around an "Apple" computer.

Positioning the LDV system at each station and translating the measuring volume through the test section proved to be somewhat strenuous and inaccurate. A base which would allow the LDV platform and, therefore, the measuring volume to translate horizontally in two dimensions would alleviate this problem. A set of simple calibrated worm gears with manually operated handles could be used as the positioning mechanism.

Inspection of the laser plasma tube cooling jacket revealed mineral deposits on the jacket inner liner. Mineral deposits on this liner reduce the capability of the laser to

reject waste heat and, therefore, reduce the life expectancy of the plasma tube. Because of this discovery a water-to-water heat exchanger has been designed and is being built. This heat exchanger will use tap water to cool an isolated quantity of water which will, in turn, pass through the plasma tube cooling jacket. The heat exchanger has built in filters which will remove contaminants and control the ion concentration in the cooling water. This heat exchanger should be in place in January 1983.

VI Conclusions

The Annular Diffuser Research Facility depicted in Figure 5 was assembled and checked out. Following the development of data collection techniques representative laser doppler velocimeter data was collected and analyzed. The following conclusions are drawn based on the results of this investigation.

1. Using velocity indications from the TSI model 1980 signal processor digital display the average flow velocity in the Annular Diffuser Research Facility test sections can be determined within plus or minus one foot per second (four percent of the flow channel centerline velocity). This margin of error is a result of the presence of turbulence in the test sections which causes the velocity indications on the digital display to fluctuate. No quantitative determination of the turbulence intensity is available from the digital display. A higher degree of average velocity data accuracy and turbulence intensity data will only be available when a data acquisition system is incorporated into the Facility.

2. Placement of the laser doppler velocimeter measuring volume requires the manual translation of the 300 pound LDV laser, optics and mounting table and the manual placement of the LDV focusing lens. This means of locating the measuring volume is strenuous, tedious and slightly inaccurate.

3. A cigarette smoke seeder and a TSI Incorporated model 9306A atomizer are each satisfactory to seed the test section of the Annular Diffuser Research Facility. The atomizer, using glycerin as the seeding material, produced the best results.

4. The mineral content of the Wright-Patterson Air Force Base water supply is shortening the life expectancy of the LDV laser by reducing the capability of the laser to reject waste heat.

VII Recommendations

In 1982 the second phase of the design and fabrication of an Annular Diffuser Research Facility was completed. The Facility depicted in Figure 5 was assembled and checked out. A data collection effort was carried out to study the capability of the Facility. The following recommendations are made based on the results of this study.

1. Purchase and incorporate a TSI Incorporated model 6200 data acquisition system to collect, reduce and analyze the LDV data.
2. Design and fabricate a two degree of freedom mounting platform capable of translating the LDV laser and optics train horizontally.
3. Complete construction on the closed loop laser heat exchanger. Connect this device to the LDV system laser.

Bibliography

1. Cocanower, A. B., Kline, S. J. and Johnson, J. P. "A Unified Method for Predicting the Performance of Subsonic Diffusers of Several Geometries." Stanford University, Report PD-10, May 1965.
2. Kelley, J. V. Design, Fabrication and Testing of an Axisymmetric, Annular, Subsonic Diffuser and Associated Instrumentation Systems. MS Thesis. Wright-Patterson AFB, Ohio: Air Force Institute of Technology, December 1981.
3. Crawford, M. E. and Kays, W. M. Convective Heat and Mass Transfer. New York: McGraw-Hill Book Company, 1980.
4. Callen, W. R., O'Shea, D. S. and Rhodes, W. T. Introduction to Lasers and Their Applications. London: Addison Wesley Publishing Company, 1978.
5. White, H. E. Introduction to College Physics. New York: D. Van Nostrand Company, 1968.
6. Adrian, R. J. and Fingerson, L. M. Laser Anemometry: Theory, Applications and Techniques. TSI Incorporated LDV short course text. St. Paul, Minnesota: TSI Incorporated, 1982.
7. TSI LDV-879-23M-2MBRI. Laser Velocimetry Systems. Product brochure and technical summary. St. Paul, Minnesota: TSI Incorporated, 1979.
8. Rothbart, H. A. Mechanical Design and Systems Handbook. New York: McGraw-Hill Book Company, 1974.
9. Larson, H. A. Professor and Head, Aero-Design Center, School of Engineering, Air Force Institute of Technology (personal interview). Wright-Patterson AFB, Ohio, March 15, 1982.
10. Shapiro, A. H. The Dynamics and Thermodynamics of Compressible Fluid Flow. New York: John Wiley and Sons Incorporated, 1953.
11. Kreyszig, E. Advanced Engineering Mathematics. New York: John Wiley and Sons Incorporated, 1979.
12. Katz, D. L. and Knudsen, J. G. Fluid Dynamics and Heat Transfer. New York: McGraw-Hill Book Company, 1958.
13. Drain, L. E. "Doppler Velocimetry." Laser Focus , Vol. 16, No. 10, October 1980.

Appendix A:
Representative LDV Data

The following laser doppler velocimeter data was taken at the Annular Diffuser Research Facility. Three sets of data are listed for each of the four data collection stations.

Station # 1 (4.6 cm behind the trailing edges of the IGV's)

Distance from the centerline of the flow channel (mm). (outer wall = 13.5mm)	Data Set		
	#1	#2	#3 * .
12			15
11	18	19	18.5
10	20	21	22
9	21	23	24
8	22	24	25
7	23	25	26.5
6	25	26	27
5	27	27	27.5
4	27	27	28
3	28	27	28
2	28	28	28.5
1	28	28	28
0	28	28	28
-1	28	28	28
-2	28	28	28
-3	28	28	27
-4	28	28	27.5
-5	28	28	27
-6	28	28	27
-7	28	27	26.5
-8	27	27	26.5
-9	26	26	25
-10	26	24	23.5
-11		23	20
-12			16
(inner wall = -13.5 mm)			

* Increased operator proficiency resulted in successful collection of velocity data near test section walls at all four stations during the third data collection effort. The third set of data collected at each station is represented in Figures 13 through 16.

Station #2 (11.0 cm behind the trailing edges of the IGV's)

Distance from the centerline of the flow channel (mm). (outer wall = 13.2 mm)	Data Set		
	#1	#2	#3
12			20
11	21	23	23
10	22	24	23
9	22	25	23.5
8	23	25	25
7	24	26	
6	25	26	26
5	26	27	26.5
4	26	28	27
3	26	27	27
2	26	27	28
1	26	27	29
0	27	28	28
-1	27	28	28.5
-2	27	28	28
-3	27	28	28.5
-4	27	28	28
-5	27	27	27.5
-6	27	27	27.5
-7	26	26	27
-8	24	25	27
-9		24	26
-10			23
-11			20
-12			17.5
(inner wall = -13.2 mm)			

Station #3 (21.0 cm behind the trailing edges of the IGV's)

Distance from the centerline of the flow channel (mm).	Data Set		
	#1	#2	#3
(outer wall = 15.5 mm)			
15			12
14			17
13			19.5
12	18	21	20
11	19	20	20.5
10	20	22	21
9	20	22	22
8	20	22	23
7	21	22	23
6	22	22	23
5	22	23	23.5
4	23	23	
3	23	23	24
2	23	23	24.5
1	24	24	24.5
0	24	24	25
-1	24	25	24.5
-2	24	25	24.5
-3	24	25	24
-4	24	24	24
-5	24	24	24
-6	23	24	24
-7	23	24	23
-8	23	24	23.5
-9	23	24	23
-10	23	22	22
-11	23	23	21
-12	22	21	20.5
-13	21	21	18
-14		19	15
-15			13
(inner wall = -15.5 mm)			

Station #4 (26.0 cm behind the trailing edges of the IGV's)

Distance from the centerline the flow channel (mm). (outer wall = 21.3 mm)	Data Set		
	#1	#2	#3
20			7.5
19		10	9
18		12	10
17		14	11
16	17	14	12.5
15	16	13	12
14	17	13	13.5
13	18	15	13
12	18	16	15
11	18	15	16
10	18	16	17
9	19	17	17
8	20	18	17.5
7	20	18	17
6	20	18	18
5	21	19	18.5
4	22	19	
3	21	19	18.5
2	21	19	18
1	21	19	18.5
0	21	20	18.5
-1	22	20	20
-2	22	20	20
-3	21	20	19.5
-4	21	20	19
-5	21	21	19
-6	21	20	19.5
-7	21	20	19.5
-8	20	20	19
-9	19	19	19.5
-10	19	19	19
-11	18	19	18.5
-12	17	18	18.5
-13	17	18	17.5
-14	17	17	17
-15	16	16	16
-16	16	15	15
-17		14	13
-18		13	13
-19		12	11
-20			8.5

(inner wall = -21.3 mm)

Appendix B:
LDV System Dimensions

The Annular Diffuser Research Facility laser doppler velocimeter has the following optical and measuring volume dimensions:

$f_l = 480 \text{ mm}$
 $D_e = 4.69 \text{ mm}$
 $K = 7.78 \text{ deg}$
 $\lambda = 514.5 \text{ nm}$
 $d_f = 1.90 \text{ }\mu\text{m}$
 $d_m = 67.7 \text{ }\mu\text{m}$
 $l_m = 495 \text{ }\mu\text{m}$
 $N_f = 36 \text{ fringes}$

VITA

Richard McCrea Moore was born August 19, 1955 in San Antonio, Texas. He graduated from Fremont Union High School in Sunnyvale, California in 1973. He received the degree of Bachelor of Science in Aeronautical Engineering from the United States Air Force Academy in June 1977. As a Lieutenant in the Air Force he was assigned to Eglin Air Force Base, Florida as an Air Force Advanced Guided Weapons Test Engineer. He entered the School of Engineering, Air Force Institute of Technology in April 1981.

Permanent Address: 2914 N. Parker St.
Colorado Springs, CO
80907

REPORT DOCUMENTATION PAGE		READ INSTRUCTIONS BEFORE COMPLETING FORM
1. REPORT NUMBER AFIT/GAE/AA/82D-20	2. GOVT ACCESSION NO. AD-A124 714	3. RECIPIENT'S CATALOG NUMBER
4. TITLE (and Subtitle) DESIGN, FABRICATION AND INSTRUMENTATION OF AN ANNULAR DIFFUSER RESEARCH FACILITY		5. TYPE OF REPORT & PERIOD COVERED MS THESIS
		6. PERFORMING ORG. REPORT NUMBER
7. AUTHOR(s) Richard McCrea Moore Captain USAF		8. CONTRACT OR GRANT NUMBER(s)
9. PERFORMING ORGANIZATION NAME AND ADDRESS Air Force Institute of Technology (AFIT-EN) Wright-Patterson AFB, OH 45433		10. PROGRAM ELEMENT, PROJECT, TASK AREA & WORK UNIT NUMBERS 62203F, 3066, 05
11. CONTROLLING OFFICE NAME AND ADDRESS AFWAL/POTC Wright Patterson AFB, OH 45433		12. REPORT DATE December 1982
		13. NUMBER OF PAGES 60
14. MONITORING AGENCY NAME & ADDRESS (if different from Controlling Office)		15. SECURITY CLASS. (of this report) Unclassified
		15a. DECLASSIFICATION/DOWNGRADING SCHEDULE
16. DISTRIBUTION STATEMENT (of this Report) Approved for public release; distribution unlimited		
17. DISTRIBUTION STATEMENT (of the abstract entered in Block 20, if different from Report)		
18. SUPPLEMENTARY NOTES Approved for public release: IAW AFB 100-17. <i>Lynn E. Wolaver</i> LYNN E. WOLAVER Dean for Research and Professional Development: Air Force Institute of Technology (ATC) Wright-Patterson AFB, OH 45433 19 JAN 1983		
19. KEY WORDS (Continue on reverse side if necessary and identify by block number) Diffuser Annular Diffuser Laser Doppler Velocimeter		
20. ABSTRACT (Continue on reverse side if necessary and identify by block number) Annular diffuser and annular diffuser inlet velocity profile data is required to verify theoretical annular diffuser velocity profile prediction techniques. This document records the advancements made during the second phase of an effort to fabricate and instrument an Annular Diffuser Research Facility. A laser doppler velocimeter, which is the primary component of instrumentation, was assembled and proper operation was verified. A stilling chamber was fabricated to provide uniform, non-separated flow at the entrance to the preexisting		

annular test section components. Velocity profile data was collected and analyzed and repeatability was demonstrated at four axial stations within the annular diffuser and annular diffuser inlet test sections