

AD-A124 729

INTERMEDIATE RAILROAD CONTROL AND STATION COMMUNICATION  
POSTS TYPES PPT-66D AND PPT-66P(U) FOREIGN TECHNOLOGY  
DIV WRIGHT-PATTERSON AFB OH 13 JAN 83  
FTD-ID(RS)T-1779-82

1/1

UNCLASSIFIED

F/G 17/2

NL

END

FILED

DTIC

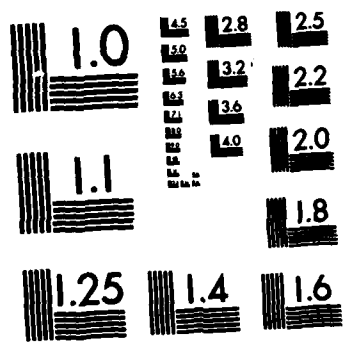

MICROCOPY RESOLUTION TEST CHART  
NATIONAL BUREAU OF STANDARDS-1963-A

2

FTD-ID(RS)T-1779-82

# FOREIGN TECHNOLOGY DIVISION



INTERMEDIATE RAILROAD CONTROL AND STATION  
COMMUNICATION POSTS TYPES PPT-66D AND PPT-66P



**S** DTIC  
ELECTE **D**  
FEB 22 1983  
B

Approved for public release;  
distribution unlimited.

DTIC FILE COPY

AD A124729



88 02 022 198

## EDITED TRANSLATION

FTD-ID(RS)T-1779-82

13 January 1983

MICROFICHE NR: FTD-83-C-000046

INTERMEDIATE RAILROAD CONTROL AND STATION  
COMMUNICATION POSTS TYPES PPT-66D AND PPT-66P

English pages: 20

Source: GOST 5.924-71, pp. 1-17

Country of origin: USSR

Translated by: Carol S. Nack

Requester: FTD/TQCC

Approved for public release; distribution unlimited.

THIS TRANSLATION IS A RENDITION OF THE ORIGINAL FOREIGN TEXT WITHOUT ANY ANALYTICAL OR EDITORIAL COMMENT. STATEMENTS OR THEORIES ADVOCATED OR IMPLIED ARE THOSE OF THE SOURCE AND DO NOT NECESSARILY REFLECT THE POSITION OR OPINION OF THE FOREIGN TECHNOLOGY DIVISION.

PREPARED BY:

TRANSLATION DIVISION  
FOREIGN TECHNOLOGY DIVISION  
WP.AFB, OHIO.

U. S. BOARD ON GEOGRAPHIC NAMES TRANSLITERATION SYSTEM

Block	Italic	Transliteration	Block	Italic	Transliteration
А а	<i>А а</i>	A, a	Р р	<i>Р р</i>	R, r
Б б	<i>Б б</i>	B, b	С с	<i>С с</i>	S, s
В в	<i>В в</i>	V, v	Т т	<i>Т т</i>	T, t
Г г	<i>Г г</i>	G, g	У у	<i>У у</i>	U, u
Д д	<i>Д д</i>	D, d	Ф ф	<i>Ф ф</i>	F, f
Е е	<i>Е е</i>	Ye, ye; E, e*	Х х	<i>Х х</i>	Kh, kh
Ж ж	<i>Ж ж</i>	Zh, zh	Ц ц	<i>Ц ц</i>	Ts, ts
З з	<i>З з</i>	Z, z	Ч ч	<i>Ч ч</i>	Ch, ch
И и	<i>И и</i>	I, i	Ш ш	<i>Ш ш</i>	Sh, sh
Й й	<i>Й й</i>	Y, y	Щ щ	<i>Щ щ</i>	Shch, shch
К к	<i>К к</i>	K, k	Ъ ъ	<i>Ъ ъ</i>	"
Л л	<i>Л л</i>	L, l	Ы ы	<i>Ы ы</i>	Y, y
М м	<i>М м</i>	M, m	Ь ь	<i>Ь ь</i>	'
Н н	<i>Н н</i>	N, n	Э э	<i>Э э</i>	E, e
О о	<i>О о</i>	O, o	Ю ю	<i>Ю ю</i>	Yu, yu
П п	<i>П п</i>	P, p	Я я	<i>Я я</i>	Ya, ya

\*ye initially, after vowels, and after ь, ь; e elsewhere.  
When written as ë in Russian, transliterate as yë or ë.

RUSSIAN AND ENGLISH TRIGONOMETRIC FUNCTIONS

Russian	English	Russian	English	Russian	English
sin	sin	sh	sinh	arc sh	sinh <sup>-1</sup>
cos	cos	ch	cosh	arc ch	cosh <sup>-1</sup>
tg	tan	th	tanh	arc th	tanh <sup>-1</sup>
ctg	cot	cth	coth	arc cth	coth <sup>-1</sup>
sec	sec	sch	sech	arc sch	sech <sup>-1</sup>
cosec	csc	csch	csch	arc csch	csch <sup>-1</sup>

Russian English

rot curl

lg log

GRAPHICS DISCLAIMER

All figures, graphics, tables, equations, etc. merged into this translation were extracted from the best quality copy available.



Accession For	
NTIS GRA&I	<input checked="" type="checkbox"/>
DTIC TAB	<input type="checkbox"/>
Unannounced	<input type="checkbox"/>
Justification	
By _____	
Distribution/	
Availability Codes	
Dist	Avail and/or Special
A	

**INTERMEDIATE RAILROAD CONTROL AND STATION COMMUNICATION POSTS  
TYPES PPT-66D AND PPT-66P**

Quality Requirements for Certified Products

State Standard of the USSR [GOST] 5.924-71

By resolution of the State Standards Committee of the Council of Ministers USSR of 19 May 1971, No. 964; time of introduction set at 1 August 1971.

This standard applies to intermediate control and station posts types PPT-66D and PPT-66P with tone dialing, which are designed for organizing communications in railroad transportation over steel circuits which may or may not be coil-loaded on a cable, as well as over channels of high-frequency wire and radio-relay communication lines.

When supplied for export, the intermediate posts must meet the requirements of GOST 10.15-69.

According to the established procedure, these intermediate posts have been given the State Seal of Quality.

**1. TYPES, MAIN PARAMETERS AND DIMENSIONS**

1.1. The intermediate posts should be manufactured in two versions:

PPT-66D - controller communications intermediate post;

PPT-66P - station communications intermediate post.

1.2. The main parameters of the intermediate posts should correspond to those given in Table 1.

Table 1.

Name of parameters	Standards
1. Resonant frequencies of circuit units, Hz	316 <sub>+6</sub> : 430 <sub>+9</sub> : 585 <sub>+12</sub> : 795 <sub>+16</sub> : 1080 <sub>+22</sub> : 1470 <sub>+29</sub> : 2000 <sub>+40</sub>
2. Sensitivity to voltage at receiver input, mV: for first call pulse for second call pulse	40-70 50-80
3. Passband, %, not less than	4.5
4. Protection factor from adjacent call frequencies, from 2nd, 3rd and 5th harmonic, not less than	3
5. Protection factor from self-blocking of II electronic relay, not less than	2
6. Modulus of input impedance in frequency range of 300-2400 Hz, kohms, not less than: during reception: during transmission:	15 10
7. Frequency of generator of intermediate post type PPT-66P, Hz	1600 <sub>+32</sub>
8. Voltage of 1600 Hz call frequency measured on line terminals, V, not less than	1.5

1.3. Articles which are used in the intermediate posts must have the overall dimensions given in Figures 1-4.

1.4. Telephone sets must be of the table-wall type designs.

1.5. The mass of the assembly parts must not exceed:

PRU-66: 6 kg; TAP-66: 1.8 kg; TAD-66: 1.6 kg;  
 ShchV-66: 1.8 kg; ShchVI-66E: 2 kg.

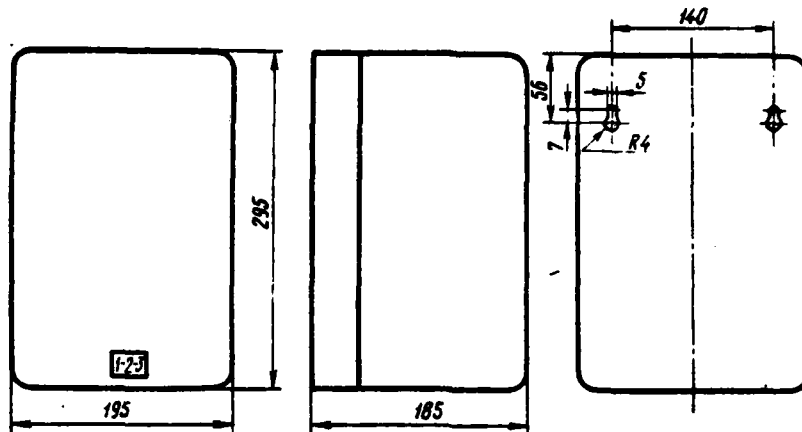

Fig. 1. Receiver-amplifier type PRU-66.

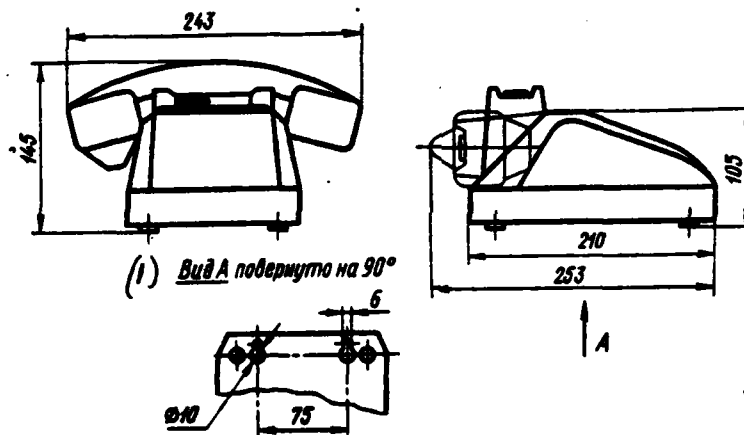

Fig. 2. Telephone set type TAD-66. KEY: (1) View A turned by 90°. NOTE: The microtelephone is not shown.

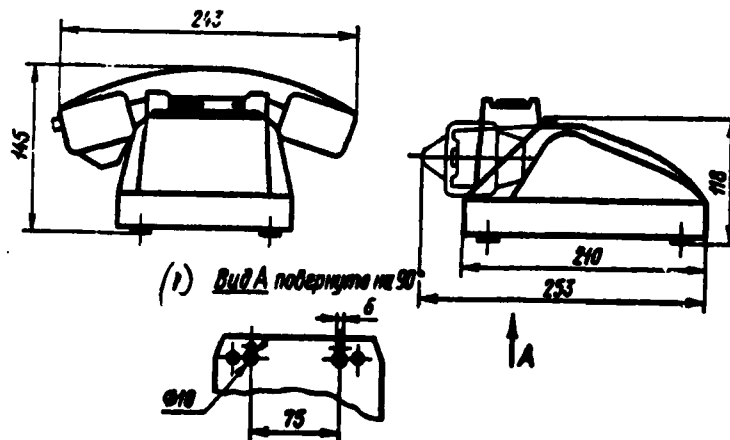

Fig. 3. Telephone set type TAP-66. KEY: (1) View A turned by 90°. NOTE: The microtelephone is not shown.

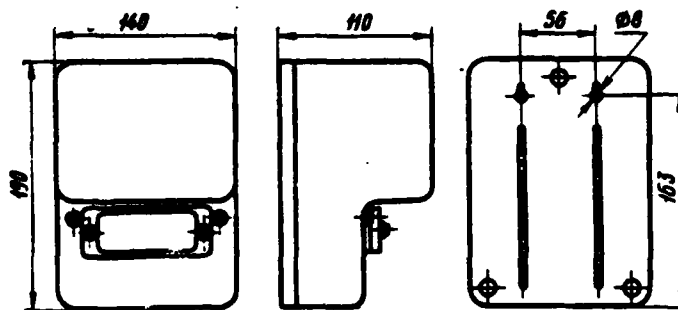

Fig. 4. Input board type ShchV-66 and input-insulating board type ShchVI-66E.

## 2. SPECIFICATIONS

2.1. The intermediate posts must be manufactured according to the specifications of this standard and the technical documentation confirmed according to the established procedure.

2.2. The materials, assembly parts and fastening articles for the intermediate posts must agree with the existing standards and technical documentation confirmed according to the established procedure.

2.3. The intermediate posts must be supplied from a battery comprised of dry cells with a total voltage of 6 V or from a storage battery with a voltage of 6, 12 or 24 V.

The current consumption must correspond to that indicated in Table 2.

Table 2.

Measurement conditions	Power source	
	Dry cell battery	Storage battery
During reception of a call, mA, not more than	60	160
During a conversation, mA, not more than	10	80

2.4. The intermediate posts should operate reliably under the following operating conditions:

- a) fluctuation of the supply voltage from minus 10 to plus 20%;
- b) ambient temperature from 0 to plus 50°C;
- c) ambient relative humidity of 65±15%;
- d) atmospheric pressure of 750±30 mm Hg (100±4 kN/m<sup>2</sup>).

2.5. The intermediate posts should provide:

the reception of individual, group and circular calls coming from the switching station;

the transmission of the call reception control signal to the line;

sending a call to the switching station for station communication (PPT-66P);

amplification of talk and call currents.

2.6. During reception, the frequency characteristic of the intermediate post amplifier should correspond to the data given in Table 3.

Table 3.

(1) Род линии	Длина линии, м (2)	(3) Напряжение на выходе, мВ, на частотах		
		300 Гц (4)	800 Гц (4)	2400 Гц (4)
(5) Стальная	0—40	75±19	110±28	120±30
	40—80	80±21	170±43	360±90
	80—120			
(6) Непульсированный кабель	30	100±25	270±68	620±155

KEY: (1) Type of line. (2) Length of line. (3) Voltage at input, mV, on frequencies of. (4) Hz. (5) Steel. (6) Non-coil-loaded cable.

2.7. The frequency characteristic of the intermediate post amplifier during transmission should correspond to the data given in Table 4.

Table 4.

(1) Род линии	Длина линии, (2) км	(3) Напряжение на выходе, мВ, на частотах		
		300 Гц <sup>(4)</sup>	800 Гц <sup>(4)</sup>	2400 Гц <sup>(4)</sup>
(5) Стальная	0-40	-	210±60	-
	40-80	-	420±120	-
	80-120	-	-	-
(6) Непульсированный кабель	30	500±150	850±250	1100±330

KEY: (1) Type of line. (2) Length of line. (3) Voltage on output, mV, on frequencies of. (4) Hz. (5) Steel. (6) Non-coil-loaded cable.

2.8. The amplitude characteristic of the amplifier should be rectilinear with a permissible deviation of  $\pm 10\%$  up to the output voltage:

during reception - up to 1900 mV;

during transmission - up to 1400 mV.

2.9. The protection circuit of the input board should correspond to GOST 5238-66.

2.10. The attenuation generated by input-insulating board type ShchVI-66E in the "intermediate post - line" transmission channel and in the "line - intermediate post" reception channel should not exceed 0.45 dB (0.05 Np) in the frequency range of 300-2400 Hz.

2.11. The metal and nonmetallic (inorganic) coatings should be made in accordance with the requirements of GOST 14623-69 for operating conditions of group S, and of the fastening parts - for operating conditions of group L.

2.12. Paint-and-varnish coatings should be done according to GOST 9894-61, class II, for operating conditions of group P.

2.13. The insulation of all the current-carrying parts of the receiving-amplifying device going to the housings of the amplifier and receiver units must withstand an alternating-current voltage of 500 V with a frequency of 50 Hz for one minute without breakdown and discharge-type phenomena.

2.14. The insulation between the current-carrying parts of the boards which have conductive coupling with line wires to any metal part which is not electrically connected to the circuit must withstand an alternating-current voltage of 1000 V with a frequency of 50 Hz for two minutes without breakdown and discharge-type phenomena.

2.15. The resistance of the insulation between all current-carrying parts which are connected to each other, insulated from the housing, and the housings of the amplifier and receiver units should be at least 3 Mohms.

2.16. The resistance of the insulation between all of the current-carrying parts connected to each other and any mechanical part of the boards should be at least 10 Mohms.

2.17. The base and case of the receiving-amplifying device must be made of molding material of group 03 according to GOST 5689-66.

2.18. The probability of failure-free operation with a confidence probability of  $P^* = 0.8$  for 1000 h should be 0.92.

### 3. PARTS LIST

3.1. The parts list of the intermediate post should include the articles, technical documentation and installation parts indicated in Table 5.

3.2. The intermediate posts should be assembled in pairs with the settings 1-2-3 and 4-5-6. Every three pairs of intermediate posts should have two circuit units tuned to a frequency of 2000 Hz (type 7).

3.3. The technical documentation indicated in Table 6 should be included for each board.

Table 5.

(1) Наименования	(2) Количество для типов		(3) Примечание
	ППТ-66Д	ППТ-66П	
(4) Устройство приемно-усилительное типа ПРУ-66	1	1	—
(5) Аппарат телефонный типа ТАП-66	—	1	—
(5) Аппарат телефонный типа ТАД-66	1	—	—
(6) Щиток вводно-изолирующий типа ШВИ-66Э			Поставляются по отдельным (15) заказам
(7) Щиток вводной типа ШВ-66			
(8) Техническое описание	1	1	На 4 промежуточных (16) пункта
(9) Паспорт	1	1	—
(10) Контурный блок (тип 7)	2	2	(17) На 3 пары промежуточных пунктов
(11) Штепсельная колодка	2	2	—
(12) Крышка	2	2	—
(13) Винт М3×12 кл. 2-001 ГОСТ 1491-62	8	8	—
(14) Кабель ТСКВ-5×2	3,5 м	3,5 м	—

KEY: (1) Name. (2) Number for types. (3) Comments. (4) Receiving-amplifying device type PRU-66. (5) Telephone set type. (6) Input-insulating board type ShchVI-66E. (7) Input board type ShchV-66. (8) Specifications. (9) Rating sheet. (10) Circuit unit (type 7). (11) Receptacle. (12) Cover. (13) Screw M3x12, cl. 2-001. (14) Cable. (15) Supplied on individual orders. (16) For 4 intermediate posts. (17) For 3 pairs of intermediate posts.

Table 6.

(1) Наименования	(2) Количество для типов		(3) Примечание
	ШВИ-66Э	ШВИ-66	
(4) Техническое описание	1	1	(6) На 5 щитков
(5) Паспорт	1	1	

KEY: (1) Name. (2) Number for types. (3) Comments. (4) Specifications. (5) Rating sheet. (6) For 5 boards.

#### 4. RULES OF RECEPTION

4.1. Intermediate posts must undergo technical testing by the manufacturer.

4.2. Intermediate posts are subjected to acceptance-release tests, periodic tests, and reliability tests.

4.3. Each intermediate post is subjected to acceptance-release tests in the volume and sequence indicated in Table 7.

Table 7.

(a) Вид испытаний	(b) Номера пунктов настоящего стандарта	
	(c) Технические требования	(d) Методы испытаний
1. Внешний осмотр и комплектность	2.1; 2.17; 3.1; 3.3	5.2
2. Измерение значений резонансных частот контурных блоков	(f) Табл. 1 (п. 1)	5.9
3. Измерение чувствительности по напряжению на входе приемника	(f) Табл. 1 (п. 2)	5.11
4. Измерение частотных и амплитудных характеристик усилителей приема и передачи	2.6; 2.7; 2.8	5.15; 5.16
5. Измерение частоты генератора промежуточного пункта типа ППТ-66П	(f) Табл. 1 (п. 7)	5.18
6. Проверка на работоспособность	2.5	5.8
7. Проверка изоляции и сопротивления изоляции	2.13; 2.14; 2.15; 2.16	5.20; 5.21
8. Измерение затухания, вносимого вводно-изолирующим щитком типа ШВ-66Э	2.10	5.19
9. Проверка монтажа вводного щитка ШВ-66	2.9	5.3

KEY: (a) Types of tests. (b) Numbers of points in this standard. (c) Technical requirements. (d) Test methods. (e) Table. (f) §.  
 (1) External inspection and presence of all parts. (2) Measurement of values of resonant frequencies of circuit units. (3) Measurement of sensitivity for voltage at receiver input. (4) Measurement of frequency and amplitude characteristics of reception and transmission amplifiers. (5) Measurement of frequency of generator of intermediate post type PPT-66P. (6) Efficiency testing. (7) Testing insulation and insulation resistance. (8) Measuring the attenuation created by input-insulating board type ShchVI-66E. (9) Testing wiring of input board ShchV-66.

If a deviation of an intermediate post from the requirements of even one point in this standard is detected during the acceptance-release tests, the intermediate post is rejected. Repeated tests of the rejected intermediate point are conducted after the defects have been eliminated: the entire set of acceptance-release tests is conducted.

4.4. Periodic tests of the intermediate posts are conducted at least once a year, as well as during changes in circuitry, design, materials, and technological processes which affect the technical parameters of the article.

The periodic tests are conducted in the volume and sequence indicated in Table 8.

Table 8.

(a) Виды испытаний	(b) Номера пунктов настоящего стандарта	
	(c) Технические требования	(d) Методы испытаний
1. Все испытания, указанные в табл. 7	Табл. 1 (пп. 1, 2, 7); 2.1; 2.5; 2.6; 2.7; 2.8; 2.9; 2.10; 2.13; 2.14; 2.15; 2.16; 2.17; 3.1; 3.3	5.2; 5.3; 5.8; 5.9; 5.11; 5.15; 5.16; 5.18; 5.19; 5.20; 5.21
2. Измерение полосы пропускания	(e) Табл. 1 (п. 3)	5.12
3. Измерение коэффициента защищенности	(e) Табл. 1 (пп. 4, 5)	5.13
4. Измерение модуля входного сопротивления	(e) Табл. 1 (п. 6)	5.17
5. Измерение напряжения вызывной частоты 1600 Гц на линейных клеммах	Табл. 1 (п. 8)	5.18
6. Проверка работы промежуточных пунктов при изменении питающего напряжения на минус 10% и плюс 20%	2.4а	5.5
7. Измерение расхода тока	2.3	5.6
8. Климатические испытания	2.4а, г, д; 2.11; 2.12	5.7
9. Проверка габаритных размеров и массы	1.3; 1.5	5.4

KEY: (a) Types of tests. (b) Numbers of points in this standard. (c) Technical requirements. (d) Test methods. (e) Table. (f) §. (g) §§. (1) All tests indicated in Table 7. (2) Measurement of the passband. (3) Measurement of the protection factor. (4) Measurement of the input impedance modulus. (5) Measurement of the voltage of the call frequency of 1600 Hz on the line terminals. (6) Checking the operation of the intermediate posts during a change in the supply voltage by minus 10% and plus 20%. (7) Measurement of the current consumption. (8) Climatic tests. (9) Checking the overall dimensions and mass.

Three samples (two type PPT-66P and one type PPT-66D) are taken from a regular batch for technical testing by the manufacturer in order to conduct periodic tests.

4.5. When unsatisfactory results of the tests indicated in Table 8 are obtained for even one of the factors, repeated tests for this factor are conducted on twice the number of intermediate posts.

In the event of unsatisfactory results of the repeated tests, the entire batch in question is rejected. The results of the periodic tests include all of the products manufactured during the period between tests.

4.6. Reliability tests must be conducted at least once every three years, but not more frequently than after every 45 thousand manufactured intermediate posts.

## 5. TEST METHODS

5.1. All of the tests are conducted under normal climatic conditions: temperature of  $25 \pm 10^{\circ}\text{C}$ , relative humidity of the air of  $65 \pm 15\%$ , and atmospheric pressure of  $750 \pm 30$  mm Hg.

5.2. The tests for conformity of external appearance and presence of all parts (§§2.1, 2.17, 3.1, 3.3) are conducted by external inspection and comparison with the diagrams.

5.3. The correct wiring of boards type ShchV-66 is determined by wire identification.

5.4. The overall dimensions and mass (§§1.3, 1.5) are checked according to a measuring scale with a precision of measurement of  $\pm 1$  mm and with technical scales with precision of measurement of  $\pm 5\%$ .

5.5. The efficiency of the intermediate post during a change in the supply voltage by minus 10% and plus 20% (§2.4a) is checked by testing it for operation according to §5.7.

5.6. The current consumption (§2.3) is measured during the reception of a call (when the bell rings) and while carrying on a conversation. In order to do this, a direct-current milliammeter of a class not lower than 2.5 is connected to the common supply circuit.

5.7. The climatic tests (§2.4b, c. d) are conducted as follows: the intermediate post is placed in a heat and humidity chamber, and then in a low temperature chamber.

The temperature and humidity in the chambers should correspond to the limiting values indicated in §2.4. After the posts remain in each chamber for two hours under stable conditions, they are checked for the reliable passage of a call and conversation at the nominal supply voltage.

The state of the metal, nonmetallic (inorganic) and paint-and-varnish coatings (§§2.11, 2.12) are determined by external inspection.

5.8. The efficiency tests (§2.5) are conducted as follows: the intermediate post is connected to a calibration sensor with a dispatcher amplifier through an attenuator with attenuation of 3 Np ( $Z = 600$  ohms): then a 24 V supply is fed:

a) the sensor button corresponding to setting the given intermediate point is pressed: in this case, a bell should ring at the intermediate post, and the call verification should be heard on the loudspeaker at the switching station:

b) the circular call button is pressed and a check is made for the passage of the circular call;

c) calls which do not pass are checked by pressing the buttons corresponding to the settings adjacent to the tested intermediate post, e.g., if an intermediate post is set on 25, the adjacent settings are: 15, 35, 24, 26;

d) the passage of a call with an attenuated ringing period is tested by pressing the individual button for a long time;

e) the passage of the conversation currents is checked by conducting conversations.

5.9. In order to measure the values of the resonant frequencies of the circuit units (§1, Table 1), it is necessary to send the voltage of the resonant frequency corresponding to the measured circuit unit to the input of the circuit unit from the sound generator through a resistance of 110 kohms.

The voltage on the output of the generator (up to the resistance), equal to 13 V, is maintained throughout the measurement time and is monitored by a tube voltmeter.

The output of the unit is loaded with resistance of 6.8 kohms.

The resonance is observed from the maximum reading of the tube voltmeter which is connected to the input of the circuit unit.

The resonant frequency of the circuit unit is measured by gradually changing the generator frequency until resonance is obtained. The generator frequency is monitored by a frequency meter of at least class 0.5 or by an oscillograph and a calibration generator of at least class 0.5 on Lissajous patterns.

5.10. The receivers of the intermediate posts are tested with one set of circuit units installed as follows:

first: 430 Hz,  
second: 1470 Hz,  
third: 795 Hz.

5.11. Sensitivity (§2, Table 1) is measured at a supply voltage of 5 V as follows. To the input of the receiver, the sound generator sends the voltage of the resonant frequency of the circuit of the first electronic relay with the value at which a direct-current voltage equal to 1 V is obtained on socket  $U_{\text{r}}$ . Here the voltage at the receiver input represents the sensitivity for the first call pulse. The sensitivity for the second call pulse is measured analogously, except that the direct-current voltage on socket  $U_{\text{p}}$  should be 0.65 V, and the second electronic relay must be set into the

self-blocking mode before making the measurement.

The voltages on sockets  $U_{\pi}$  and  $U_p$  must be measured by a direct-current voltmeter with an input impedance of at least 20 kohms/V.

5.12. The passband (§3, Table 1) is measured at a voltage of 4.5 V and with short-circuiting of a 75-ohm resistor in the emitter circuit of the second electronic relay.

The passband must satisfy the following relationship:

$$\frac{2\Delta f}{f} > 0,045,$$

where  $f$  is the resonant frequency of the circuit unit:  $\Delta f$  is the difference between the resonant frequency of the circuit unit and the cut-off frequency of the passband.

The cut-off frequencies of the receiver passband are determined with an audio generator which is connected to the receiver input. The generator frequency is varied on both sides of the resonant frequency of the contour unit up to the values at which the direct-current voltage on socket  $U_{\pi}$  (when testing the first electronic relay) reaches 0.2 V, while the voltage on socket  $U_p$  (when testing the second electronic relay) becomes equal to 0.8 V. Here the voltage on the receiver input should be 400 mV.

When measuring the passband of the second electronic relay, it is necessary to set the relay in the self-blocking mode after supplying the required frequency.

5.13. The protection factor (§§4.5 of Table 1) is measured with a supply voltage of 6 V and a removed connector with a 75-ohm resistor.

The protection factor  $K$  is calculated from the formula:

$$K = \frac{U_1}{U_2},$$

where  $U_1$  is the sensitivity for the voltage at the input of the corresponding electronic relay on the resonant frequency, and  $U_2$  is the

voltage at the input of the corresponding electronic relay when the 1300 mV of the test (adjacent) frequency selected from Table 9 is supplied to the input of the receiver.

Table 9.

	Гц (4)						
(1) Номинальное значение резонансной частоты	316	430	585	795	1080	1470	2000
(2) Нижняя испытательная частота	—	324	441	600	815	1107	1505
(3) Верхняя испытательная частота	419	570	775	1053	1433	1950	—

KEY: (1) Nominal value of resonant frequency. (2) Lower test frequency. (3) Upper test frequency. (4) Hz.

The sensitivity on the resonant frequency is determined from the direct-current voltage on the sockets:

$U_{тз}$  - 1 V - for the first electronic relay,

$U_p$  - 0.55 V - for the second electronic relay.

Table 10.

	Гц (5)				
(1) Номинальное значение резонансной частоты	585	795	1080	1470	2000
(2) По второй гармонике	308	419	570	775	1053
(3) По третьей гармонике	—	—	324	441	600
(4) По пятой гармонике	—	—	—	308	419

KEY: (1) Nominal value of resonant frequency. (2) For second harmonic. (3) For third harmonic. (4) For fifth harmonic. (5) Hz.

In order to determine the protection factor from the second, third and fifth harmonics, a voltage of 1300 mV, which corresponds to the test frequency selected from Table 10, is sent to the input, and the voltage on the input of the corresponding electronic relay is measured.

The value of the protection factor is calculated as described above.

In order to determine the protection factor from self-blocking

of the second electronic relay, the voltage of the resonant frequency, which is increased until the moment of blocking ( $U_p$  not less than 0.55 V) of the second [sic] electronic relay ( $U_1$ ), is sent to its input. Then the voltage of 1300 mV of the resonant frequency of the second electronic relay is sent to the input of the receiver, and in this case, the voltage on the input of the second electronic relay ( $U_2$ ) is measured. The value of the protection factor from self-blocking is calculated from the above formula.

5.14. The tests of the intermediate post amplifiers (§§5.15, 5.16) are conducted at a supply voltage of 5 V.

5.15. The characteristics of the intermediate post amplifier are checked during reception (§§ 2.6, 2.8) as follows: an audio generator is connected to the input of the amplifier. This generator sends a voltage of 100 mV on frequencies of 300, 800 and 2400 Hz. A terminating resistor of 6.8 kohms, a tube voltmeter and an oscillograph are connected to the conversation line of the amplifier. A terminating resistor of 3.9 kohms is connected to the call line of the amplifier.

5.16. The characteristics of the amplifier during transmission (§§2.7, 2.8) are checked as follows. An audio generator, from which a voltage of 30 mV on frequencies of 300, 800 and 2400 Hz is fed, is connected instead of a microphone. A terminating resistor (600 ohms), a tube voltmeter, and an oscillograph are connected to the line terminals. A connector is installed on the unit instead of a push-to-talk key.

5.17. The modulus of the input impedance of the intermediate post (§6, Table 1) is checked as follows. A series-connected audio generator and a resistance box are connected to the line terminals according to the diagram shown in Fig. 5.

The modulus of the input impedance of the amplifier during reception on frequencies of 300, 800 and 2400 Hz, with a supplied power from the ZG [audio generator] of 100 mV, is determined by means of comparison with the power on.

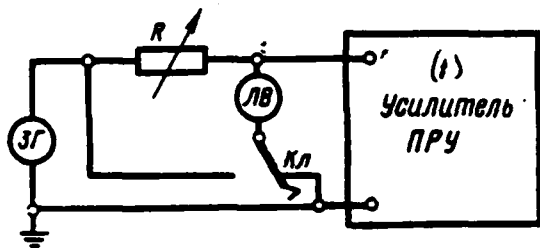

Fig. 5. ZG - audio generator; LV - tube voltmeter; R - Resistance box; Kl - key contact.  
KEY: (1) Amplifier.

The input impedance modulus during transmission is measured analogously. The voltage supplied from the ZG during these measurements should be 1 V, and a connector should be installed on the unit instead of push-to-talk keys.

5.18. In order to measure the frequency and voltage of the generator of intermediate post type PPT-66P (§§7, 8, Table 1), it is necessary to connect a frequency meter of at least class 0.5 and a tube voltmeter to the line terminals, which are loaded with resistance of 600 ohms. The measurements are made with the microtelephone disconnected and the call button pressed.

5.19. The attenuation generated by board type ShchVI-66E (§2.10) is checked according to the diagrams given in Figures 6 and 7.

5.19. The attenuation generated by board type ShchVI-66E (§2.10) is checked according to the diagrams given in Figures 6 and 7.

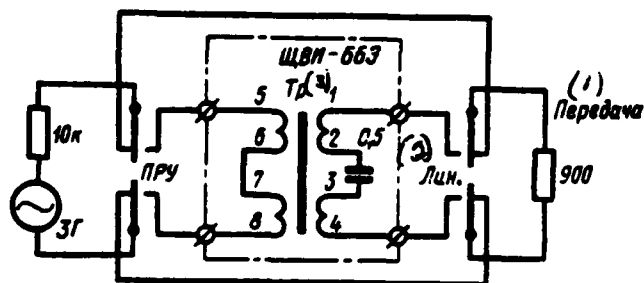

Fig. 6. KEY: (1) Transmission. (2) Line. (3) Tr.

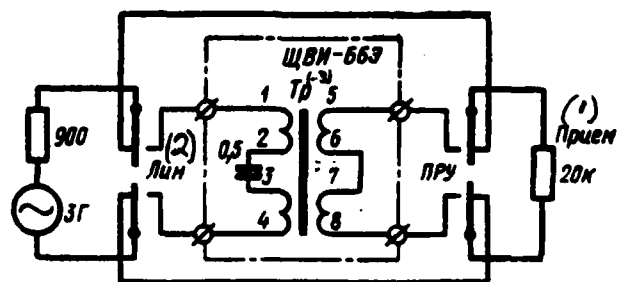

Fig. 7. KEY: (1) Reception. (2) Line. (3) Tr.

The signal level on the load without an insulating transformer should be 0 dB (0 Np).

The attenuation is defined as the difference between the levels on the load with the insulating transformer on and off.

5.20. The electrical strength of the insulation (§§2.13, 2.14) is

checked using an alternating-current source with a power of 0.5 kVA, a frequency of 50 Hz, and an essentially sinusoidal form of the voltage curve.

The polarized relay is removed before testing the receiving-amplifying device. The toggle switches are turned on before testing the boards.

5.21. The resistance of the insulation (§§2.15, 2.16) is measured by any method with a maximum error of  $\pm 20\%$  at a test voltage of at least 500 V for boards, and at least 200 V for the receiver-amplifier.

5.22. The quality of the materials and assembly parts (§2.2) is checked from the certificates, specifications, standards, and other supplier documents.

5.23. The reliability tests (§2.18) are conducted according to GOST 13216-67 under laboratory conditions.

## 6. MARKING, PACKAGING, TRANSPORTATION AND STORAGE

6.1. On the base of the receiver-amplifier and the board there should be a metal plate, photographically reproduced, which contains the following data:

- a) the trade mark of the manufacturer;
- b) the State Seal of Quality according to GOST 1.9-67;
- c) the sequence number of the issue number of the current year;
- d) the designation of this standard;
- e) the issue year.

6.2. The following should be written on the housings of the telephone sets, the cases of the receiving-amplifying device, and the boards: the State Seal of Quality according to GOST 1.9-67, the manufacturer's trade mark. Tables and diagrams indicating the type, sequence number and year of issue should be attached to the inside of the telephone housings and board cases.

6.3. The imprint corresponding to its type must be made on the board case.

6.4. The following should be used to package the intermediate posts:

a) corrugated cardboard boxes type I (Fig. 2) according to GOST 9142-59;

b) noncollapsible crates type II (Fig. 2) according to GOST 2991-69 with internal dimensions (box No. 189 and 221) according to GOST 8872-63;

c) wrapping paper according to GOST 8273-57;

d) bituminous paper according to GOST 515-56;

e) twine according to GOST 5725-51;

f) wood shavings according to GOST 5244-50.

6.5. Each receiver-amplifier, each telephone set with the accompanying documentation according to Table 5, and each board with the enclosure according to Table 6 must be packed in the appropriate corrugated cardboard boxes, and a label which simultaneously serves as a wrapper must be glued on.

6.6. The following must be written on the label:

the State Seal of Quality according to GOST 1.9-67,

the manufacturer's trade mark,

the name and type of intermediate post,

warning notices for transportation according to GOST 14192-69.

The corresponding setting 1-2-3 or 4-5-6 is also indicated for the receiving-amplifying device.

6.7. The intermediate posts must be packaged without corrosion proofing.

6.8. Not more than the following quantities should be packed in the crates:

- a) intermediate posts - 6 sets;
- b) boards - 10.

The gross mass should not be more than:

- for intermediate posts - 70 kg,
- for boards - 40.

6.9. Besides the intermediate posts, the crates should include the specifications according to Tables 5 and 6, as well as a packing list drawn up by the packager and equipped with the technical control stamp indicating the data of packaging.

6.10. Any closed transport can be used to transport the intermediate posts and boards, as long as the requirements established by the warning signs on the packing boxes according to GOST 14192-69 are observed.

When transported in railroad containers, the intermediate posts do not have to be placed in crates. In this case, the intermediate posts should be laid in rows. Sheets of plywood or cardboard partitions should be placed between each row horizontally.

6.11. The intermediate posts and boards should be stored in closed rooms in the cardboard packaging at an ambient temperature of from plus 1 to plus 40°C with a relative humidity of 65±15% and in the absence of dust and vapors of acids, alkalies and other active substances which cause corrosion.

## 7. MANUFACTURER'S GUARANTEE

7.1. The manufacturer guarantees that the intermediate posts meet the requirements of this standard as long as the user observes the operating and storage conditions established by this standard.

7.2. The guarantee period is 24 months from the day the article is brought into operation, but not more than 36 months from the day the intermediate post is shipped to the user.

3-8

DT