

AFWAL-TR-82-3043

2

AD A1 24949

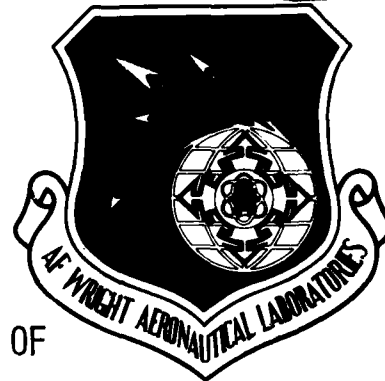

EXPERIMENTAL ANALYSIS OF THE PERFORMANCE OF
AN ANNULAR PERIPHERAL JET VEHICLE IN GROUND EFFECT

MECHANICAL BRANCH
VEHICLE EQUIPMENT DIVISION

October 1982

Final Report for Period August 1980 to January 1982

Approved for Public Release; Distribution Unlimited.

DTIC FILE COPY

FLIGHT DYNAMICS LABORATORY
AIR FORCE WRIGHT AERONAUTICAL LABORATORIES
AIR FORCE SYSTEMS COMMAND
WRIGHT-PATTERSON AIR FORCE BASE, OHIO 45433

DTIC
ELECTE
S FEB 25 1983 D
D

10 0 001 018

NOTICE

When Government drawings, specifications, or other data are used for any purpose other than in connection with a definitely related Government procurement operation, the United States Government thereby incurs no responsibility nor any obligation whatsoever; and the fact that the government may have formulated, furnished, or in any way supplied the said drawings, specifications, or other data, is not to be regarded by implication or otherwise as in any manner licensing the holder or any other person or corporation, or conveying any rights or permission to manufacture, use, or sell any patented invention that may in any way be related thereto.

This report has been reviewed by the Office of Public Affairs (ASD/PA) and is released to the National Technical Information Service (NTIS). At NTIS, it will be available to the general public, including foreign nations.

This technical report has been reviewed and is approved for publication.

RICHARD J. ALMASSY, Capt, USAF
Project Engineer

AIVARS V. PETERSONS
Chief, Mechanical Branch
Vehicle Equipment Division

FOR THE COMMANDER

SOLOMON R. METRES
Director, Vehicle Equipment Division
Flight Dynamics Laboratory

"If your address has changed, if you wish to be removed from our mailing list, or if the addressee is no longer employed by your organization please notify AFWAL/FIEMB, W-PAFB, OH 45433 to help us maintain a current mailing list".

Copies of this report should not be returned unless return is required by security considerations, contractual obligations, or notice on a specific document.

UNCLASSIFIED

SECURITY CLASSIFICATION OF THIS PAGE (When Data Entered)

REPORT DOCUMENTATION PAGE		READ INSTRUCTIONS BEFORE COMPLETING FORM
1. REPORT NUMBER AFWAL-TR-82-3043	2. GOVT ACCESSION NO. AD-A124949	3. RECIPIENT'S CATALOG NUMBER
4. TITLE (and Subtitle) EXPERIMENTAL ANALYSIS OF THE PERFORMANCE OF AN ANNULAR PERIPHERAL JET VEHICLE IN GROUND EFFECT		5. TYPE OF REPORT & PERIOD COVERED Final Technical Report Aug 1980 - Jan 1982
		6. PERFORMING ORG. REPORT NUMBER
7. AUTHOR(s) Richard J. Almassy, Capt, USAF		8. CONTRACT OR GRANT NUMBER(s)
9. PERFORMING ORGANIZATION NAME AND ADDRESS Mechanical Branch Vehicle Equipment Division		10. PROGRAM ELEMENT, PROJECT, TASK AREA & WORK UNIT NUMBERS 24020129
11. CONTROLLING OFFICE NAME AND ADDRESS Flight Dynamics Laboratory (AFWAL/FIEMB) AF Wright Aeronautical Laboratories, AFSC Wright-Patterson Air Force Base, Ohio 45433		12. REPORT DATE October 1982
		13. NUMBER OF PAGES 42
14. MONITORING AGENCY NAME & ADDRESS (if different from Controlling Office)		15. SECURITY CLASS. (of this report) UNCLASSIFIED
		15a. DECLASSIFICATION/DOWNGRADING SCHEDULE
16. DISTRIBUTION STATEMENT (of this Report) Approved for Public Release; Distribution Unlimited.		
17. DISTRIBUTION STATEMENT (of the abstract entered in Block 20, if different from Report)		
18. SUPPLEMENTARY NOTES		
19. KEY WORDS (Continue on reverse side if necessary and identify by block number) Peripheral Jet Vehicles Air Cushion Vechicles (ACV) Air Cushion Landing Systems (ACLS) Ground Effect Takeoff and Landing (GETOL)		
20. ABSTRACT (Continue on reverse side if necessary and identify by block number) Two annular peripheral jet air cushion models were designed, fabricated and tested in-house at the Mobility Development Laboratory (AFWAL/FIEMB) at Wright-Patterson AFB, OH. The vehicles were designed to attain maximum hover height at a fixed level of available power based on Barratt Theory, and achieve maximum static hover stability. The assumptions and analytic development of Barratt Theory are discussed, as well as some design aspects to achieve vehicle cushionborn stability. Test results indicated Barratt lift predictions to be slightly conservative. Both vehicles were unstable at high hover heights in		

UNCLASSIFIED

SECURITY CLASSIFICATION OF THIS PAGE(When Data Entered)

20. Abstract

their basic configurations. The addition of several configurations of vertical strakes compartmenting the cushion area achieved varying improvements to vehicle stability. The addition of full cushion depth cruciform strakes completely stabilized the vehicles. Vehicle instability was concluded to be caused by aerodynamic activity in the cushion area induced by shear from high momentum jet airflow.

UNCLASSIFIED

SECURITY CLASSIFICATION OF THIS PAGE(When Data Entered)

PREFACE

This report describes the design and testing of an annular peripheral jet air cushion vehicle. The program was an in-house research program conducted by members of the Special Projects Group (FIEMB), Mechanical Branch (FIEM), Vehicle Equipment Division (FIE), Flight Dynamics Laboratory, Air Force Wright Aeronautical Laboratories, Wright-Patterson AFB, Ohio 45433. This work was accomplished under Project 2402, "Advanced Aircraft Vehicle Equipment"; Task 240201, "Mechanical Systems for Advanced Military Flight Vehicles"; Work Unit 24020129, "Advanced Takeoff and Landing Systems Development/Test/Evaluation."

This report covers the test program conducted during the period 1 Aug 1980 through 31 Jan 1981, under direction of the author, Captain Richard J. Almasy, Project Engineer. Release of the report was by the author 29 January 1982.

In appreciation of their ideas and technical support given during this program, the author wishes to thank Mr David J. Pool (AFWAL/FIEMB) and Colonel (Retired) George F. Cudahy (AFFDL/CC).

Accession For	
NTIS GRA&I	<input checked="" type="checkbox"/>
DTIC TAB	<input type="checkbox"/>
Unannounced	<input type="checkbox"/>
Justification	
By _____	
Distribution/	
Availability Codes	
Dist	Avail and/or Special
A	



TABLE OF CONTENTS

SECTION	PAGE
I INTRODUCTION	1
1 Statement of Problem	1
2 Background	1
3 Approach	4
II PERIPHERAL JET STATIC LIFT THEORY	5
1 Introduction	5
2 Barratt Theory Assumptions	5
3 Summary of Static Lift Equations	8
4 Design Parameter Relationships	11
5 Lift Augmentation Ratio	12
III MODEL TEST PROGRAM	14
1 Introduction	14
2 Model Designs	14
3 Test Procedures	17
IV RESULTS	24
1 Static Hover Performance	24
2 Vehicle Stability	27
V CONCLUSIONS AND RECOMMENDATIONS	30
1 Static Lift Power	30
2 Vehicle Dynamics Analysis	31
REFERENCES	33

LIST OF ILLUSTRATIONS

FIGURE		PAGE
1	Peripheral Jet Air Cushion System	2
2	Peripheral Jet Geometry	6
3	Definition of System Areas	9
4	Peripheral Jet Model Optimum Baseline Design	16
5	Radially Compartmented Diffuser	18
6	Lift System Components	19
7	Fan Performance Map	20
8	30° Annular Peripheral Jet Model	21
9	Static Hover Test Arrangement	22
10	Lift Augmentation, Theory versus Measured	25
11	Mass Flow, Theory versus Experiment	26
12	Full Span Cruciform Strakes	28

LIST OF SYMBOLS

- A_c The projection of the air cushion area contained by the peripheral jet on the ground surface (Ft^2).
- A_j The projection of the peripheral jet exit area on the ground surface (Ft^2).
- A_{p_j} The actual peripheral jet nozzle exit area measured normal to the jet airflow (Ft^2).
- A_T The projection of the total vehicle undercarriage area contained by and including the peripheral jet (Ft^2 Note: $A_T = A_c + A_j$).
- d The vertical daylight clearance under the cushionborne vehicle (Ft).
- F_c The total vertical force generated by pressure forces in the cushion area of the cushionborne vehicle (lbs).
- F_j The total vertical force generated by the thrust of the peripheral jet of the cushionborne vehicle (lbs).
- L_{pj} Total verticle force (lift) generated by the peripheral jet system (lbs).
- \vec{n} Outward unit normal vector to an arbitrary surface.
- P Pressure at an arbitrary point (PSFG).
- P_c The cushion pressure of the cushionborne vehicle (PSFG).
- P_a Ambient pressure (PSFG).
- P_R The system pressure ratio P_c/P_T .
- P_T The total pressure differential across the lift fan (PSFG).
- Q Air volume flow through system (Ft^3/sec).
- R Radius (Ft).
- S Perimeter of peripheral jet (Ft).
- t The thickness of the peripheral jet airflow at the nozzle exit, measured normal to the airflow (Ft).
- V_j The velocity of a fluid element along an arbitrary jet streamline (Ft/sec).
- \bar{V}_j Average velocity of jet airflow (Ft/sec).
- W Weight (lbs).

LIST OF SYMBOLS CONTINUED

- ρ Density of air (Slugs/Ft³).
- θ Jet angle measured from vehicle vertical axis (Degrees).

SECTION I
INTRODUCTION

1. STATEMENT OF PROBLEM

The objectives of this program were to investigate the static hover performance of a peripheral jet air cushion system at high lift conditions and investigate suspected sources of cushion-induced vehicle instabilities. It was initiated as a high risk/high payoff, largely experimental program to rapidly develop peripheral jet technology as a potential replacement for the conventional landing gear on future aircraft. Ground Effect Takeoff and Landing (GETOL) is a concept where aircraft flotation is provided by a peripheral jet lift system rather than struts, wheels, and tires. GETOL differs from most Air Cushion Landing Systems (ACLS) concepts in that no external trunks, skirts, fingers, or other appendages are used to contain the air cushion region. It could provide future aircraft with unprecedented mobility, allowing sustained operations from unprepared or semiprepared surfaces, including battle damaged airfields.

The program objectives were formulated to expedite GETOL development. They were based on perceived technology needs from past GETOL and peripheral jet studies. The intended program payoff was to demonstrate that attractive hover performance and vehicle stability could be obtained from moderately simple modifications to the basic peripheral jet lift systems design, and that the peripheral jet GETOL system was a technically feasible concept for future aircraft.

2. BACKGROUND

A peripheral jet air cushion system generates lift by maintaining a static volume of higher than atmospheric pressure air beneath the vehicle (Figure 1). This volume of air, called the cushion, is prevented from venting to the atmosphere by the momentum of the jet airflow surrounding it. Significant daylight clearances can theoretically be obtained from modest power requirements by the proper combination of airflow, pressure, and jet geometry. The primary technological problems have been excessive power requirements due to design constraints, and vehicle instability at high lift conditions for single cushion vehicles.

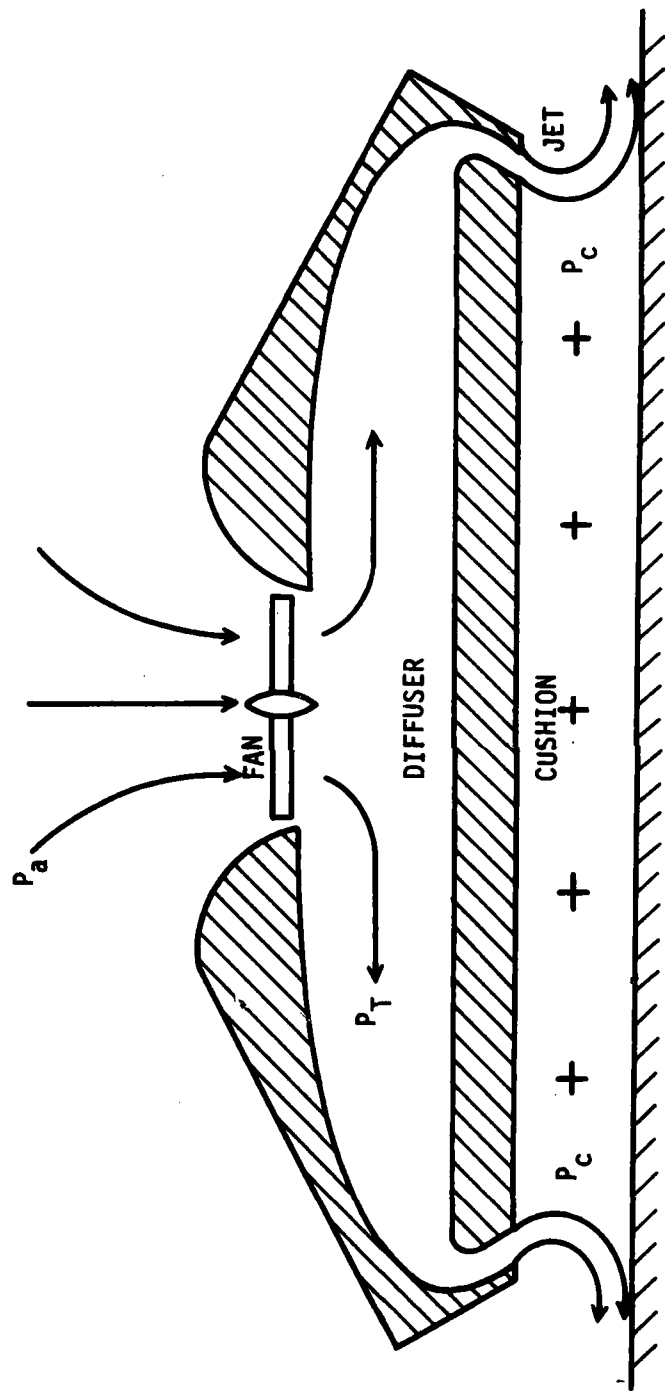

Figure 1. Peripheral Jet Air Cushion System

Three significant studies involving the GETOL concept were conducted by AVRO Canada; General Dynamics, Convair Division; and Lockheed Georgia Corporation.

The AVROCAR, built by AVRO Canada in the 1950's, used an annular peripheral jet lift system to support a manned vehicle (Reference 1). The GETOL AIRPLANE was a peripheral jet seaplane concept investigated by Convair for the US Navy in the early 1960's (Reference 2). In both these studies, however, stringent design requirements resulted in excessive lift power requirements to make the concepts appear technically attractive. The PERIPHERAL JET AIR CUSHION LANDING SYSTEM SPANLOADER AIRCRAFT study was conducted by Lockheed in the late 1970's (Reference 3). Using a 1.5 million pound gross weight Spanloader design as a baseline, the study concluded that a GETOL augmentation system in combination with a conventional landing gear could reduce the necessary gear span from 218 feet to 75 feet, without significantly changing the useful load of the aircraft. The significance of the Lockheed program is that it was perhaps the first to document the potential superiority of peripheral jet flotation over conventional mechanical means in terms of weight, space requirements, and operational performance. Additional power requirements to operate the air cushion system were very low compared with flight power requirements of a 1.5 million pound vehicle. However, the predicted capability was based on optimized analytic theory and not empirical data.

Many other programs have analytically and experimentally investigated peripheral jet performance. This program was to be a simple, qualitative, experimental investigation of two performance aspects identified by Flight Dynamics Laboratory (FDL) as critical to the feasibility of a viable GETOL system. First, investigate the high lift hover capabilities of an annular jet obtained from optimal jet configurations as predicted by Barratt Theory (Reference 4). And second, improve the lateral stability performance at hover of a simple annular peripheral jet, which tends to exhibit a characteristic "wobble" type instability when cushionborne. Initially, the intent was to isolate the first order source of the instability. If successful, a secondary intent was to experimentally develop passive stability augmentation for the system.

3. APPROACH

Two annular peripheral jet models were constructed and tested. The models differed only in jet geometry. Each was designed to obtain maximum static hover ground clearance for the specific jet configuration (as predicted from Barratt Theory). Static hover capability was measured as a function of vehicle weight (lift force capability) with the vehicle vertically constrained. Dynamic stability was qualitatively observed during vehicle tethered flight. Several passive stability augmentation devices were built and tested. Their designs were intuitively developed from speculation of the driving causes of annular peripheral jet lateral vehicle instability (wobble).

SECTION II
PERIPHERAL JET STATIC LIFT THEORY

1. INTRODUCTION

In order to properly design the test models, it was necessary to obtain an analytic relationship between the system geometry and the desired performance. Barratt Theory is generally regarded as one of the simpler analytic peripheral jet theories with good experimental correlation. It was used to aid in the model configuration designs and to correlate test results with design predictions. This section discusses the assumptions and governing equations for the incompressible Barratt Theory.

2. BARRATT THEORY ASSUMPTIONS

Barratt Theory is an ideal fluid (inviscid, incompressible, homogeneous), static equilibrium analysis of peripheral jet air cushion lift. It is basically a refinement of simple (thin) jet theory (Reference 5) by attempting to analytically account for the pressure/velocity gradient which occurs across the jet.

Figure 2 shows the geometry of the peripheral jet. In addition to the ideal fluid assumptions, the following assumptions are also made:

- a. The jet flow is steady state.

$$\partial \vec{v} / \partial t = 0$$

That is, the local velocity at an arbitrary point within the jet does not vary in magnitude or direction with time. The velocity does vary from point to point across the jet, but at any discrete point, the velocity remains constant.

- b. The jet flow is irrotational.

$$\text{curl } \vec{v} = 0$$

Each element of fluid (dm in Figure 2) maintains a constant spatial orientation as it travels through the jet flow field. No vorticity and/or mixing of the fluid can occur within the jet streamlines.

NOTE: θ is positive measured from the vertical, counterclockwise.

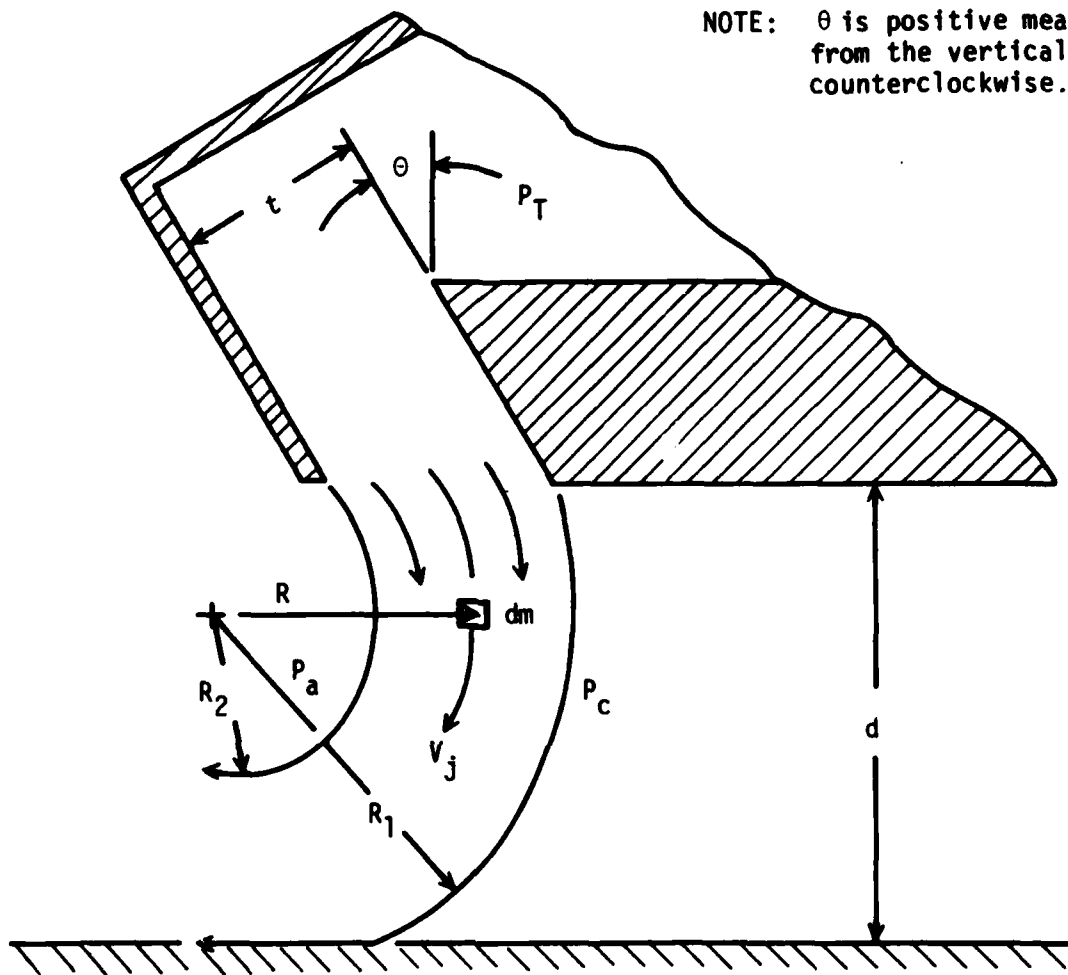

Figure 2. Peripheral Jet Geometry

c. Energy is conserved throughout the system. Loss from non-conservative sources, such as viscous heating, deformation of the vehicle or flotation surfaces, etc, is assumed negligible. As a result, the total momentum of the jet airflow is conserved. The momentum of the fully deflected airflow at the ground plane is assumed to be equal in magnitude to the airflow at the jet exit plane.

d. The effects of body forces on the fluid flow are negligible. In particular, the change in gravitational potential of a fluid element dm due to a change in height within the system is assumed to be negligible.

e. The jet streamlines are assumed to be parallel with the jet walls at the jet exit plane before being deflected and parallel with the ground plane after being fully deflected.

Collectively, these assumptions dictate several significant factors in the dynamics of the flow field. The ideal fluid, steady, irrotational flow assumptions force a condition of no mixing between the cushion air, jet airflow, and atmospheric air outside the jet. The streamlines at the jet boundaries form a stream tube, an impermeable fluid boundary across which no flow can occur. Without viscous shear, the air outside the jet boundaries is uninfluenced by the motion of the air within the jet. At equilibrium, the cushion air is a captured volume of higher than atmospheric pressure, still air.

At the jet exit plane, the only external forces acting on the stream tube are the pressure forces from the cushion and atmosphere (which act normal to the jet boundary streamlines), since all nonconservative and body forces are assumed negligible. After exiting the jet, the resultant motion of the jet is circular (from the constant centripetal force of the cushion pressure) and the jet streamlines from the jet exit plane have a common center of curvature.

The assumptions about the fluid properties were made to simplify the form of the static lift equations and still maintain reasonable accuracy. Some of the physical realities of making these assumptions will be discussed later.

3. SUMMARY OF STATIC LIFT EQUATIONS

Detailed analytic development of Barratt Theory is contained in References 4 and 6. For the purposes of this report, a brief summary is provided to develop the peripheral jet parameters used to design the experimental models.

Vertical equilibrium of the cushionborn vehicle requires that the total vertical force generated by the vehicle lift system be equal in magnitude to the vehicle weight:

$$\vec{W} = \vec{F}_c + \vec{F}_j \quad (1a)$$

where \vec{F}_c is the total force generated by the static cushion area and \vec{F}_j is the reaction of the jet.

In general terms, the cushion force is:

$$\vec{F}_c = - \oint_S P_c \vec{n} dS \quad (1b)$$

where dS is an element of the surface (S) acted upon by the cushion pressure.

For the vehicle geometry shown in Figure 3 and assuming the weight acts vertically down, the vertical component of \vec{F}_c is:

$$F_c = P_c A_c$$

The reaction of the jet may be determined from conservation of momentum of the stream tube as it is deflected through the angle $\theta + 90^\circ$ (Figure 2). The general equation is:

$$\vec{F}_j = - \oint_S V(\rho V \cdot \vec{n}) dS - \oint_S p \vec{n} dS \quad (2)$$

where dS is an element of the total surface (S) across the stream tube, normal to the flow. The first term in the equation is a summation of the change in momentum of the jet airflow, and the second term is a summation of the pressure forces of the stream tube against the ground.

Equation 2 cannot be immediately evaluated. Note that the static pressure p across the jet stream tube in the R_1 direction is not constant. The pressure at the stream surface along R_1 (Figure 2) is P_c and along R_2

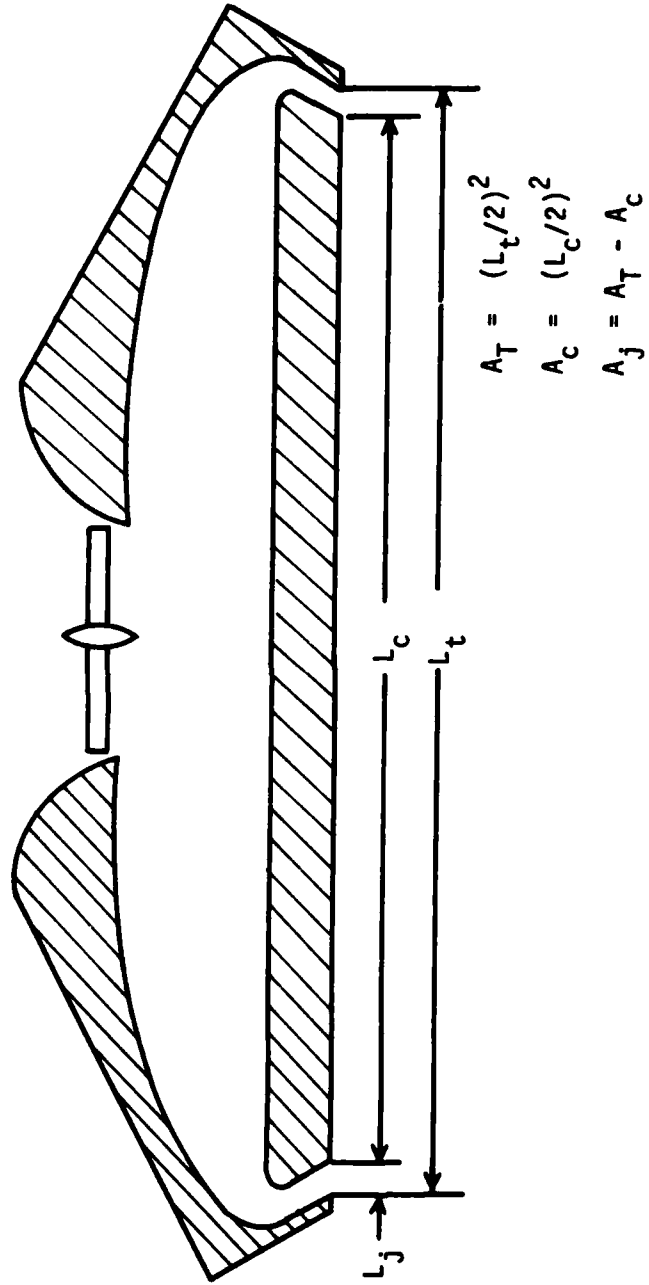

Figure 3. Definition of System Areas

is P_a . The magnitude of the velocity V across the jet is therefore also varying since conservation of energy requires:

$$P_{T/\rho} = P/\rho + V^2/2 \quad (3)$$

To evaluate Equation 2, the pressure and velocity gradients across the jet must be expressed as scalar function of the general position vector \vec{R} .

Equilibrium of forces in the \vec{R} direction on a fluid element dm (Figure 2) requires:

$$\partial P/\partial R = \rho V^2/R \quad (4)$$

Combining Equations 3 and 4 and integrating radially across the stream tube yields:

$$P(\vec{R}) = P_T + \frac{R_1^2}{R} (P_C - P_T) \quad (5)$$

and

$$v(\vec{R}) = \frac{R_2}{R} (2P_{T/\rho})^{1/2}$$

Evaluating Equation 5 for the boundary conditions at the stream tube surface yields:

$$R_2/R_1 = (1 - P_C/P_T)^{1/2} \quad (6)$$

Equation 2 can now be evaluated to find the vertical reaction of the jet:

$$F_j = 2A_j P_T (L - P_C/P_T)^{1/2} \cos^2 \theta + A_j P_C \quad (7)$$

The total vertical force (lift) generated by the peripheral jet system is then:

$$L_{pj} = P_C A_T + 2A_j P_T (1 - P_C/P_T)^{1/2} \cos^2 \theta \quad (8)$$

The total massflow required is determined from the general equation of the conservation of mass:

$$\dot{m} = -\oint_S (\rho \vec{V} \cdot \vec{n}) dS$$

which is:

$$\dot{m} = A_j \cos \theta \int_{R_1}^{R_2} 2V(R) dR \quad (9)$$

The total airflow through the peripheral jet system is:

$$Q = \dot{m} / \rho$$

or

$$Q = A_j \cos \theta \int_{R_1}^{R_2} 2V(R) dR \quad (10)$$

By combining Equations 5 and 10 and integrating across the jet yields the total airflow:

$$Q = A_j \cos \theta (2P_T / \rho)^{1/2} (1 - P_C / P_T)^{1/2} \{1 - (1 - P_C / P_T)^{1/2}\}^{-1} \{\ln(1 - P_C / P_T)^{-1/2}\} \quad (11)$$

4. DESIGN PARAMETER RELATIONSHIPS

Equations 8 and 11 define the lift system of the peripheral jet vehicle in terms of pressure requirements, which is not particularly useful from a design standpoint. More advantageous to a designer would be relationships between vehicle performance requirements and purely physical design parameters, such as vehicle size, weight, and jet geometry.

To develop such relationships, a relation between the system pressure ratio, P_C / P_T , and the system physical geometry must be developed. The area of the jet normal to the airflow will be approximated by:

$$A_{pj} = St \quad (12)$$

Force equilibrium between the cushion and the horizontal component of the jet reaction requires:

$$P_C dS = 2Stp_T (1 - P_C / P_T)^{1/2} (1 + \sin \theta) \quad (13)$$

Solving Equation 13 for the system pressure ratio yields:

$$P_C / P_T = 2\beta \{(\beta^2 + 1)^{1/2} - \beta\} \quad (14)$$

where

$$\beta \equiv t/d (1 + \sin \theta)$$

Combining Equations 8 and 14 yields a relationship between the total static pressure rise required of the vehicle lift system and purely geometric system parameters:

$$P_T = W / \{A_T P_R + 2St \cos \theta (1 - P_R)^{1/2}\} \quad (15)$$

where

$$P_R = \{2\beta (\beta^2 + 1)^{1/2} - \beta\}$$

Total power required for the vehicle lift system can be expressed by combining Equations 11 and 15, since power is:

$$\text{hp required} = \frac{QP_T}{550}$$

The resulting equation is:

$$\text{hp} = \frac{St}{550} \{\delta\}^{3/2} \left(\frac{2}{\rho}\right)^{1/2} (1 - P_R)^{1/2} \{1 - (1 - P_R)^{1/2}\}^{-1} \{\ln(1 - P_R)^{-1/2}\} \quad (16)$$

where

$$\delta \equiv W / \{A_T P_R + 2St \cos \theta (1 - P_R)^{1/2}\}$$

Equation 16 is admittedly cumbersome, but it fully quantifies the peripheral jet system as a multivariate function of power, vehicle weight, cushion size, jet geometry, and hover height. Using multivariate search techniques, the designer can determine optimal vehicle configurations for any given set of performance requirements and design restraints.

5. LIFT AUGMENTATION RATIO

The lift augmentation ratio of an air cushion vehicle is basically a system lift coefficient. There are several definitions depending on the system, but essentially it is a ratio of the total vertical force generated by an air cushion system compared with the net thrust which could be generated by a simple jet nozzle under similar flow conditions.

For the purposes of this report, the lift augmentation ratio is defined as the total vertical lift generated by the air cushion plus the vertical component of the peripheral jet thrust compared to the vertical thrust of the jet if it were directed straight down. To be reasonably consistent, the comparison should be made at very nearly equal levels of

available power, i.e., similar pressure and airflow conditions. The lift augmentation ratio is then:

$$AR = \frac{P_C A_T + 2StP_T (1-P_C/P_T)^{\frac{1}{2}} \cos\theta}{2StP_T (1-P_C/P_T)^{\frac{1}{2}}} \quad (17)$$

which reduces to:

$$AR = \cos\theta + \frac{A_T}{2St} P_R (1-P_R)^{-\frac{1}{2}} \quad (18)$$

The term in the denominator of Equation 17 describes the thrust of the jet in the presence of the cushion pressure. A free air jet, of course, would not have a nonuniform pressure gradient across the jet nozzle. However, the term is useful to quantify the amount of free air thrust that would be developed under the same available power conditions.

Notice also that the augmentation provided by the peripheral jet air cushion system is solely determined by the physical parameters hover height, jet thickness, jet angle, and cushion size.

SECTION III
MODEL TEST PROGRAM

1. INTRODUCTION

Two peripheral jet models were designed, built, and tested to analyze vehicle hover performance and assess vehicle stability. The designs were a compromise between optimum hover capability and stability consideration. The test program attempted to quantify the lifting capability of the vehicles and qualitatively assess the design tradeoffs. This section will discuss the model design considerations and describe the model test procedures.

2. MODEL DESIGNS

The initial design objective was to maximize the hover height capability of the models for a fixed level of available power. Less sensitive design parameters were than altered slightly in an attempt to improve vehicle stability.

Equation 16 was used to perform a sensitivity analysis of the design variables i.e., vehicle and jet geometries, system pressures, mass flow, etc. The equation is a relatively complex function, but it does relate the major design parameters to power available and hover height. By holding the power available constant, each dependent variable can be varied to determine its sensitivity on the resulting hover height. This technique was used and indicated the following:

- a. Hover height is maximized when cushion pressure and cushion perimeter are minimized. Therefore, a circular cushion is desirable.
- b. Hover height increases as jet angle, θ , increases.
- c. For a circular cushion area, hover height is maximized for a system pressure ratio (P_c/P_T) of approximately 0.6 to 0.8.

To simplify the design process, parameters with a relatively high sensitivity on hover height became design variables to be optimized, while parameters with a low sensitivity were chosen to be fixed states. Since

vehicle weight is usually a strong function of specified design requirements, it was selected to be a fixed state. The model physical size was selected primarily on test facility aspects and a preliminary weight estimate was made. The lift system fan and engine were selected from size constraints and power available and mass flow also became fixed states. A multivariate optimal search technique (Reference 7) (conjugate gradient method) was then performed on Equation 16 to determine the optimal values of the remaining dependent design variables. The baseline configuration parameters are shown in Figure 4.

Two model designs were derived from the baseline configuration. Slight modifications were made in an attempt to improve vehicle stability. Single cushion, peripheral jet type air cushion vehicles tend to exhibit a bilateral instability at high lift conditions. That is, they tend to wobble similar to a precessing gyroscope. Based on several theories about the sources of this instability, several unique features were incorporated in the model designs to try and defeat this tendency.

First, the jet angle was decreased from 90° to 30° to increase the cushion footprint area. The AVROCAR used a 60° jet, which was designed to focus at high lift conditions (Reference 1). The jet flow at high power adhered to the bottom of the vehicle. It flowed inward to the center of the cushion, then downward toward the ground, forming a narrow jet column with a small cushion footprint. It had been speculated that the AVROCAR experienced poor stability at high power because its narrow cushion footprint could cause large pitch changes with fairly small migrations of the center of pressure. It was hoped that decreasing the jet angle would result in less sensitive pitch changes. The first model jet was set at 30° ; the second model was designed at the first's half power point, -15° .

Another unique design feature was the radially compartmented diffuser section of the lift system. Compartmentation was accomplished by placing vanes in the diffuser section parallel to the fan exit airflow, and extending from the fan exit area to the jet exit area. The purpose of this was twofold. First, it would reduce the destabilizing moment caused by the asymmetric thrust of the jet when the vehicle was tipped. Second,

Fixed States:

Vehicle Weight	48 lbs
Jet Mass Flow (Fan nominal operating point)	40 CFS
Total Pressure Rise (Power Available)	9 PSF
Cushion Area (Size constraint)	6.9 Ft ³
Cushion Span (Diameter)	3.0 Ft

Design Variables:

Jet Area (A_{pj})	0.9 Ft ²
System Pressure Ratio (P_R)	0.8
Jet Angle (θ)	90°
Jet Thickness (t)	0.9 In
Cushion Pressure (P_c)	7 PSF

Expected Hover Height

2.3 In (Height/Span Ratio of 0.06)

Figure 4. Peripheral Jet Model Optimum Baseline Design

it would partially decouple the cushion and fan so that perturbations in the cushion and jet areas would not be transmitted back to the fan. Figure 5 is a cutaway view of the diffuser interior.

The fan selected for the model lift system was also anticipated to provide maximum vehicle stability. It was a centrifugal airflow fan (Figures 6 and 7) selected for its single functioned, high dQ/dp characteristics and flat flow response at cutoff pressure (rather than stall). A high dQ/dp characteristic provides rapid flow response to sudden changes in cushion pressure and this provides high static cushion stiffness. The flat flow response at high pressure eliminates cushion stiffness reversal and/or collapse at fan stall.

The first model (Figure 8) followed the baseline design with the exception of the jet angle, which was decreased to 30 degrees. This reduced the nominal hover height to 1.75 inches, or a height/span ratio of 0.05. The second model was also identical except the jet angle was further reduced to -15 degrees. This reduced the nominal hover height to one quarter of the optimal design value. If this configuration did not dramatically increase vehicle stability, the concept of directing the jet angle outward from the cushion was to be abandoned.

3. TEST PROCEDURES

The model test program was conducted in two phases. In phase one, static lifting force was measured with the models vertically constrained as a function of hover height. In the second phase, vehicle stability was qualitatively assessed while the models were laterally tethered but vertically in free hover flight.

The test set up for the static hover tests is shown in Figure 9. Vertical lift was measured by a strain bar mounted to the top of the vehicle. The strain bar was a simple mild steel beam with foil strain gauge networks bonded to the upper and lower surfaces. The bar was calibrated by applying known loads at the model attachment point, and the test data was subsequently corrected for the moment error caused by the model attachment point not being located vertically in line with the model



Figure 5. Radially Compartmented Diffuser



Figure 6. Lift System Components

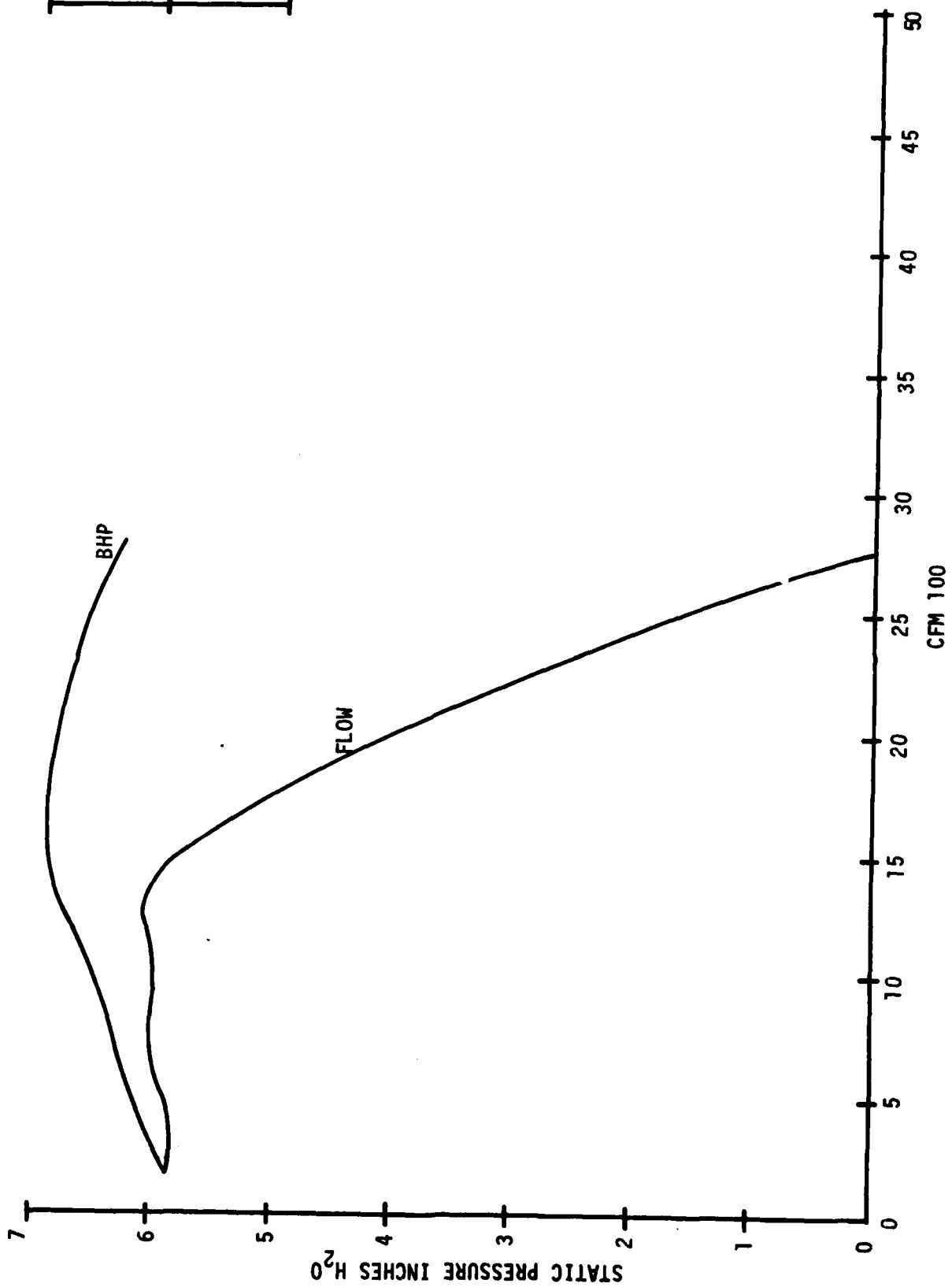

Figure 7. Fan Performance Map

AFWAL-TR-82-3043



Figure 8. 30° Annular Peripheral Jet Model

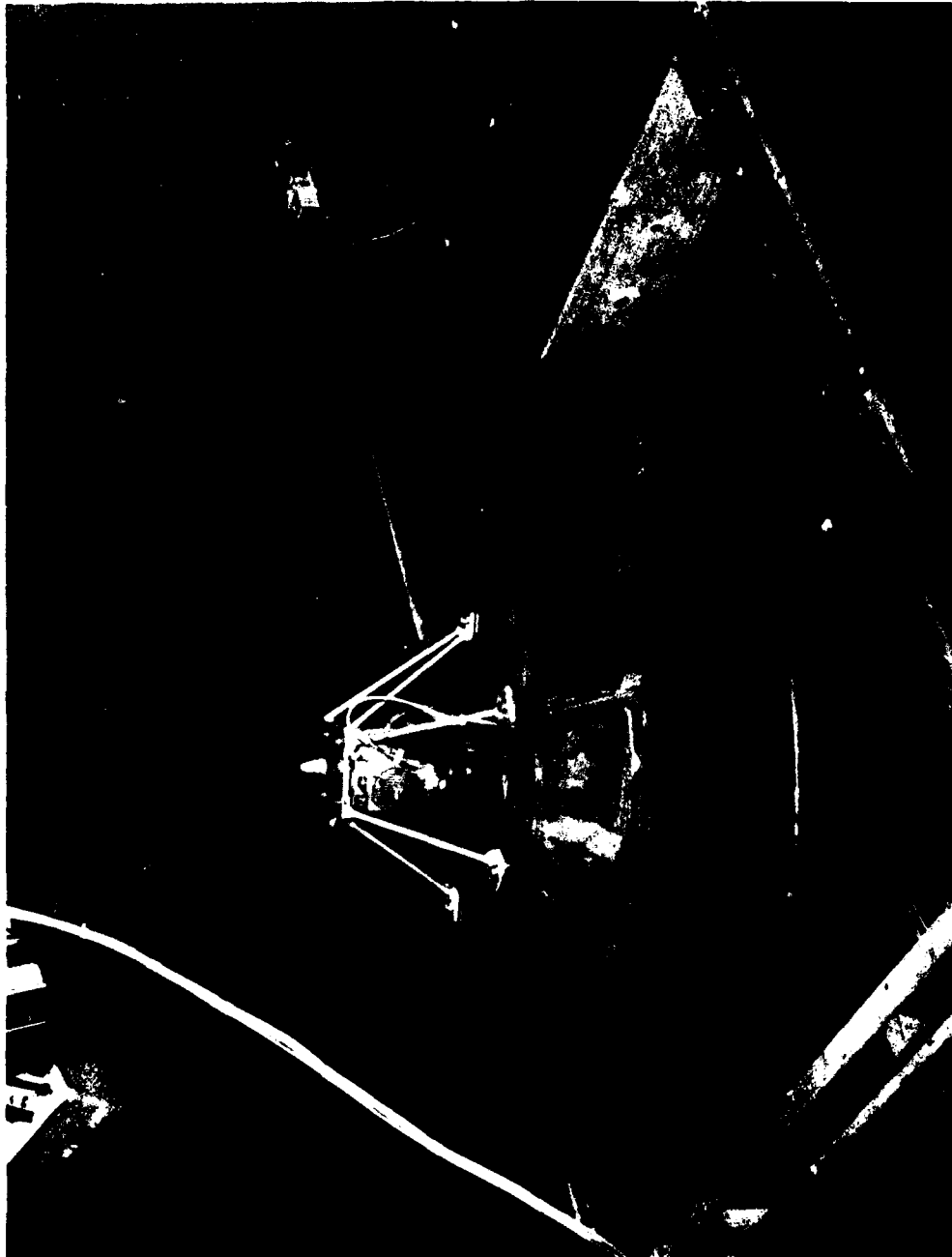

Figure 9. Static Hover Test Arrangement

theoretical center of lift. The test surface was smooth plexiglas and instrumented with pressure transducers. The pressure measurements were used to crosscheck the strain bar lift measurements and confirm the ground pressure gradient of the cushion was indeed uniform. Fan speed was held constant throughout the tests and monitored by using a strobe light. Lift system mass flow was determined from the fan map supplied by the manufacturer. The models were also instrumented with pitot tubes inside the diffuser section to confirm that the design system pressure ratio was obtained during tests.

The total vertical lift generated by the models was measured as a function of hover height by varying the height of the horizontal strain bar. The initial test performed was the measurement of the free air thrust of the peripheral jet lift system out of ground effect. The free air thrust obtained was compared to theoretical predictions to assure proper system operation and gain confidence in the fan performance predicted by the fan map. Test data was recorded on an analog paper recorder.

Dynamic hover tests were recorded on video tape. The test procedure was to bring the fan speed up slowly, and observe vehicle stability as a function of jet Reynolds Number (based on jet airflow and jet thickness). The models were tested in their basic configurations and also with several modifications to the cushion area which will be discussed in the next section.

SECTION IV

RESULTS

1. STATIC HOVER PERFORMANCE

The first test result of significance was the comparison of the measured versus theoretical free air thrust of the 30° peripheral jet model. The measured thrust was obtained by supporting the model well out of ground effect with the calibrated strain bar. The theoretical thrust was computed from the formula:

$$T = \dot{m}_j \bar{V}_j \quad (19)$$

where

$$\begin{aligned} \dot{m}_j &= \rho Q \\ \bar{V}_j &= Q/A_{pj} \end{aligned}$$

The jet mass flow was obtained from the fan performance map (Figure 7). Within the tolerances of the equipment used in this experiment, the measured thrust matched the theoretical thrust of 5.4 pounds. This result added confidence that the system was operating as predicted and the fan map was a true indication of the fan performance.

The static hover performance of the 30° peripheral jet model in ground effect is presented in Figure 10. The experimentally determined augmentation is shown as a function of hover height. The Barratt Theory curve was obtained from Equation 18. The experimental data was derived from:

$$AR = (\text{measured lift})/(\rho Q^2/A_{pj}) \quad (20)$$

where the mass flow (Q) was obtained from the fan performance map.

The results depicted in Figure 10 were not surprising. Higher than theoretically predicted augmentation for low pressure peripheral jet systems have been recorded in past experiments (References 4 and 8). In that respect, Barratt Theory appears to be conservative at operating conditions where hover height was optimized with respect to input power. The mass flow for prediction versus experiment is presented in Figure 11.

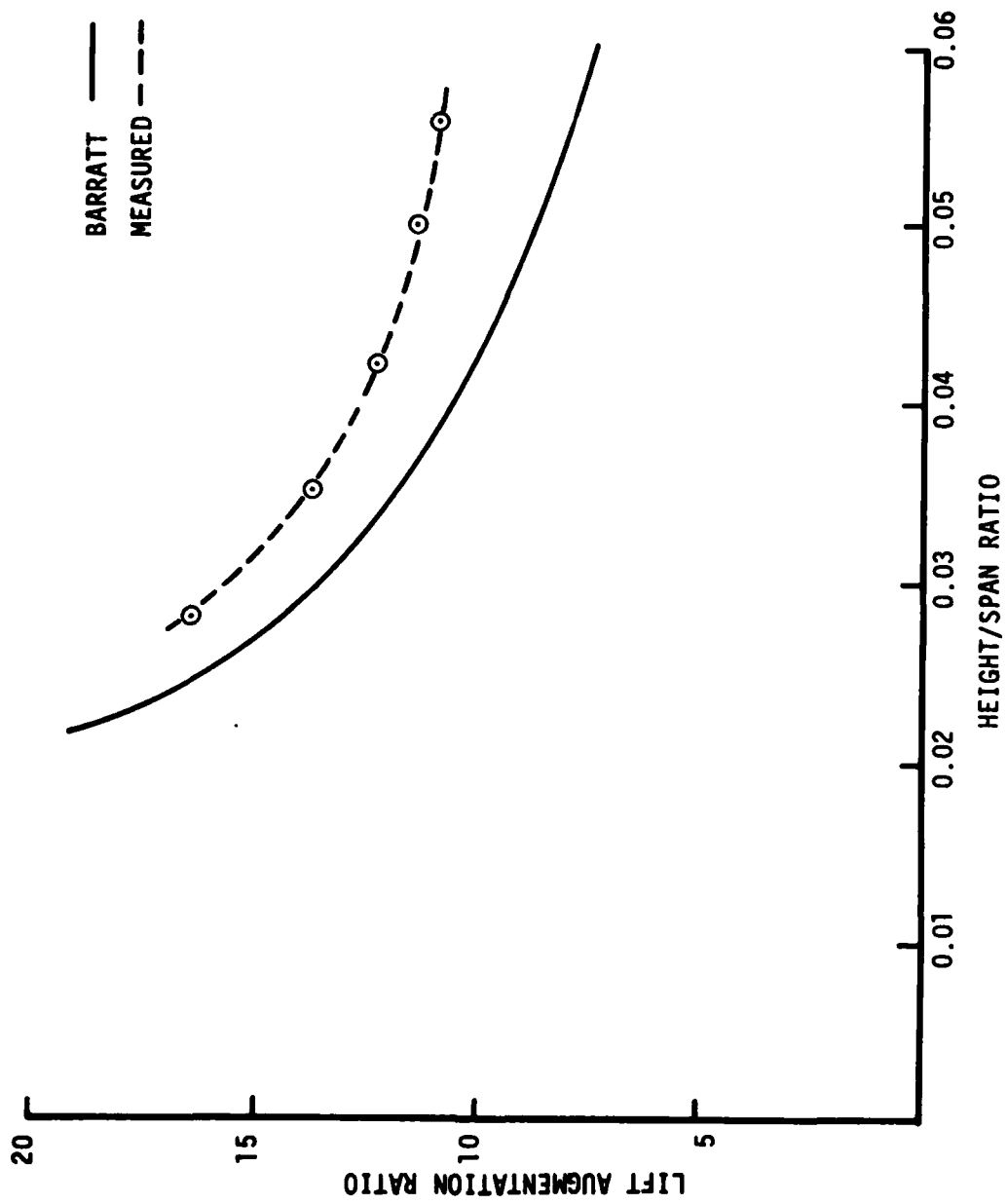

Figure 10. Lift Augmentation, Theory versus Measured

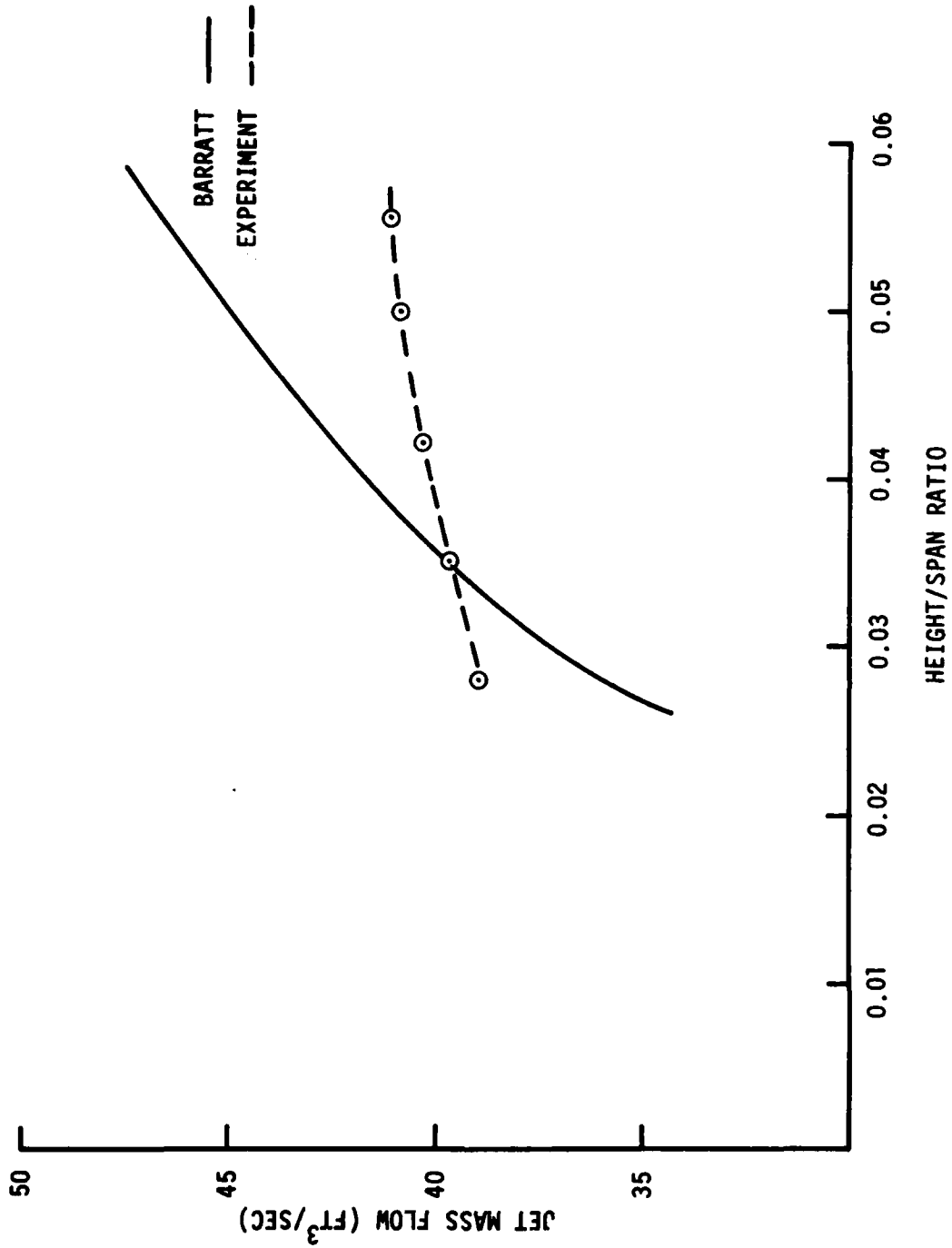

Figure 11. Mass Flow, Theory versus Experiment

2. VEHICLE STABILITY

Both models in their basic configuration were unstable at their design operating hover heights. They exhibited a low frequency (approximately 2 hertz) rhythmic "wobble" similar to a precessing top. The magnitude of the perturbation was limited only as the downgoing side of the jet struck the surface.

For the 30° jet model, the vehicle was stable at low hover heights (corresponding to low jet velocities), but began a very low frequency (approximately 0.3 hertz), small magnitude, precessing type motion at a jet Reynolds number of approximately 10^4 . The unstable motion was increasingly aggravated as jet velocity was increased. The -15° jet vehicle barely became cushionborne at a jet Reynolds number of 10^4 and was unstable at all hover heights. Testing of this model was subsequently discontinued.

It seemed apparent that the vehicle instability was somehow related to the jet Reynolds number (jet airflow velocity). It was theorized that viscous shear between the cushion and jet airflow induced vorticity along the inside stream tube boundary. The vorticity, in turn, was causing crossflows in the theoretically static cushion area, which produced an out of trim, center of pressure condition. To defeat the crossflow activity, full span cruciform strakes were attached to the bottom of the vehicle, which compartmented the cushion area into four equal quadrants (Figure 12). Vehicle stability was greatly improved.

The first strake tested extended from the bottom of the cushion approximately 30 percent of the nominal hover height. At the nominal cushionborne hover height, the vehicle motion had been reduced in frequency to approximately 0.5 hertz and the magnitude reduced to approximately one-third to one half the clearance height. A second cruciform strake of approximately 60 percent of the nominal hover height further reduced the vehicle instability to a random motion with no perceptible frequency and very small magnitudes. A 90 percent strake completely stabilized the vehicle. It exhibited excellent static stability and static cushion stiffness.

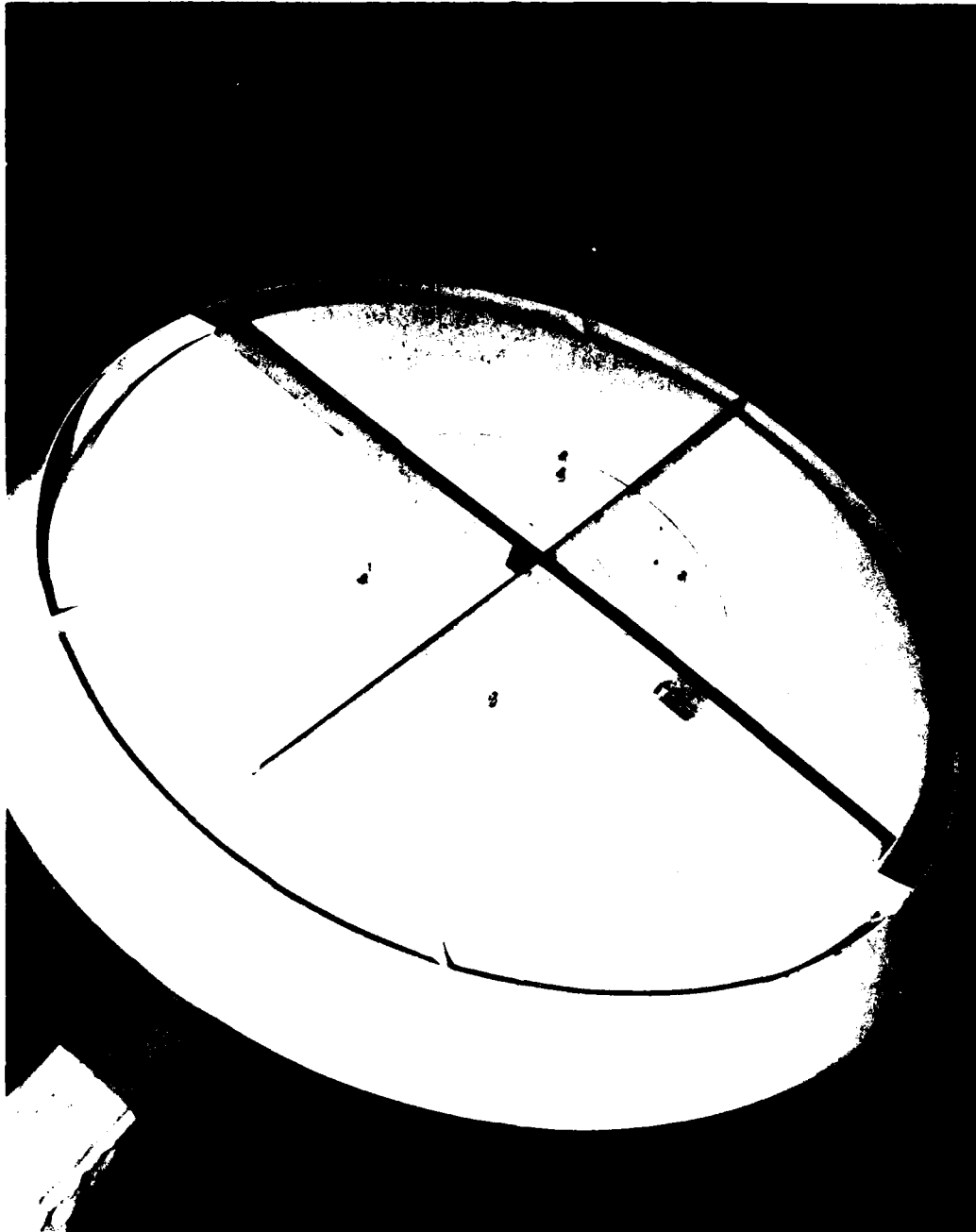

Figure 12. Full Span Cruciform Strakes

To further investigate the cushion compartmentation effect on vehicle stability, the cruciform strakes were removed and a single strake was installed. The single strake bisected the full cushion span and was approximately 90 percent of the cushion depth. When tested at the nominal operating height, the vehicle was laterally unstable along the axis of the strake and stable along an axis perpendicular to the strake. This result, along with the results above, strongly implicates the cushion crossflow theory as being the primary source of single cushion, peripheral jet vehicle lateral instability.

The final stability tests conducted were intended to investigate the cruciform strakes at less than full span configurations. Tests were conducted with only the middle half of the cushion area compartmented and also with only the outer half of the cushion area compartmented, with the cruciform strakes extending full cushion depth. In either case, the unstable motion returned.

SECTION V

CONCLUSIONS AND RECOMMENDATIONS

1. STATIC LIFT POWER ANALYSIS

The results of this experiment and others like it indicate that Barratt Theory of peripheral jet lift may be slightly conservative. As Figure 10 indicates, slightly higher augmentation ratios can be experimentally obtained in the operating region where the vehicle lift system has been optimized according to analytic predictions. It would be reasonable to conclude that the slight increase in system performance is the result of the effects of viscosity between the jet and the surrounding air.

Figures 10 and 11 indicate that the most conservative predictions from theory with respect to lift performance occur at the higher height/span ratios. The experimental flow obtained at the design operating point (height/span ratio of 0.05) would not be sufficient to generate the lift obtained according to Barratt Theory. It may be possible that the fan performed better than expected, but the free air thrust results would tend to reinforce the fan map accuracy. It would be more logical to conclude that the jet airflow is entraining additional airflow in the same principle as an air ejector (Reference 8). The physical geometries between the two are somewhat similar. Additional airflow entrained would provide additional momentum to the jet. That additional momentum would account for the increased centripetal force necessary to contain a cushion pressure higher than theoretically obtainable. And as the stability experiments indicate, there is definitely aerodynamic activity occurring between the jet and the theoretically assumed static air surrounding the stream tube boundaries.

Another indication of entrainment is the flow similarities between Figures 10 and 11. The higher the hover height the greater the gain becomes in augmentation and reduced flow requirements. This tendency would not occur solely from increased fan performance. It would appear, however, that the peripheral jet does have a propensity to entrain

airflow. The ability to entrain airflow from the viscous shear between the jet and surrounding air would be increased by the higher jet velocities and longer stream tube surfaces associated with the higher height/span ratios. It is recommended that further study be conducted to validate this conclusion. It is probable that even greater augmentation can be achieved by incorporating air ejector design principles into the peripheral jet design geometry.

Another tendency indicated by Figure 11 is a greater flow requirement at low height/span ratios. The model in this experiment was designed for a height/span ratio of 0.05. It is interesting to note that the flow requirements exceed the predicted values as the hover height (and subsequently the available jet turning radius) becomes smaller than the jet thickness. It would be difficult to conclude that the assumption of circular jet streamlines is maintained under these conditions. Consequently, the maximum cushion pressure which can be obtained is greatly diminished.

Peripheral jet air cushion systems can generate attractive flotation heights from modest power requirements through proper configuration design. Design and operational benefits of such systems for future aerospace vehicles was addressed in the Lockheed study (Reference 3) and is not addressed in this report. From a static augmentation standpoint, the technology is viable and attractive. It would be recommended to further investigate forward speed effects and transition to/from flight effects of peripheral jet augmentation systems.

2. VEHICLE DYNAMICS ANALYSIS

The baseline configurations of the peripheral jet models tested in this program were laterally unstable. The primary source of the vehicle instability was experimentally traced to aerodynamic activity in the cushion area. It was concluded that this activity is directly related to the velocity of the jet airflow, possibly through viscosity effects. It is probable that viscous shear between the jet airflow and the cushion air creates sufficient vorticity and/or random flow fields in the cushion area to alter the static trim condition of the vehicle. Although

analytical analysis will show that asymmetric thrust, unfavorable fan characteristics, and cushion/duct/fan coupled perturbances have destabilizing influences on vehicle dynamics, they were concluded to be second order effects compared to the aerodynamic influences from the cushion. It is recommended that further study be conducted to verify these conclusions are universal to peripheral jet air cushion vehicles and not unique to this experiment.

The vehicle instability found in this experiment can be controlled in two ways. The velocity of the jet airflow can be kept low, which will reduce the influence of the jet shear forces on the cushion air. However, since the hover height is dependent on the jet momentum, this technique can only be used for low hover heights, and the optimum potential of a peripheral jet system is not fully realized.

To maintain vehicle stability and still operate near optimum lift conditions for the vehicle geometry, the crossflow activity in the cushion must be eliminated. This can be accomplished by physically segmenting the cushion into separate areas. This technique may not be practical or desirable for design purposes on flight vehicles, where external appendages are usually avoided if possible. It is, therefore, recommended that alternative solutions to controlling the aerodynamic activity in the cushion area be pursued.

REFERENCES

1. J.C.M. Frost, "The Canadian Contribution to the Ground Cushion Story," C.A.I. Annual General Meeting, Toronto, Canada, May 1961.
2. W. Carter, et. al., "GETOL Research Program Final Report," General Dynamics/Convair, December 1962.
3. L.W. Lassiter, et. al., "Peripheral Jet Air Cushion Landing System Spanloader Aircraft," AFFDL-TR-79-3152, May 1979.
4. H.H. Richardson and K.M. Captain, "Simplified Static Performance Characteristics of Low Pressure Plenum and Peripheral Jet Fluid Suspensions," Massachusetts Institute of Technology, January 1968.
5. H.R. Chaplin, "Theory of the Annular Nozzle in Proximity to the Ground," David Taylor Model Basin Aero Report 923, July 1957.
6. K.H. Digges, "Theory of An Air Cushion Landing System for Aircraft," AFFDL-TR-71-50, June 1971.
7. R.L. Fox, "Optimization Methods for Engineering Design," Addison-Wesley Publishing Company, Reading Massachusetts, June 1973.
8. A.J. Alexander, "The Momentum Equation for Static Hovercraft at Zero Incidence," Journal of the Royal Aeronautical Society, February 1966.

END

FILMED

3-83

DTIC