

MICROCOPY RESOLUTION TEST CHART
NATIONAL BUREAU OF STANDARDS-1963-A

ADA 126014

①

| | | | | | |
|--|--|---|---|---|------------------|
| 1. Report No. FAA-APO-81-11-(2 of 6) | | 2. Government Accession No. AD-A126014 | | 3. Recipient's Catalog No. | |
| 4. Title and Subtitle Socioeconomic Impact Assessment: Communications Industry Phase I--Technical Appendix Description and Documentation of the Current State-of-the-Art. Volume II | | 5. Report Date February 2, 1979 | | 6. Performing Organization Code | |
| | | 8. Performing Organization Report No. | | 10. Work Unit No. (TRAVIS) | |
| 7. Author(s) | | 9. Performing Organization Name and Address Acumenics Research and Technology, Inc. 4340 East-West Highway Suite 808 Bethesda, Maryland 20814 | | 11. Contract or Grant No. DOTFA78WAI-932 | |
| 12. Sponsoring Agency Name and Address Department of Transportation Federal Aviation Administration Office of Aviation Policy and Plans Washington, D. C. 20591 | | 13. Type of Report and Period Covered Final Report | | 14. Sponsoring Agency Code APO-210 | |
| | | | | 15. Supplementary Notes | |
| 16. Abstract | | | | | |
| <div style="display: flex; justify-content: space-between;"> <div style="writing-mode: vertical-rl; transform: rotate(180deg); font-weight: bold; font-size: 2em;">DTIC FILE COPY</div> <div style="text-align: center;"> <p style="font-size: 2em; font-weight: bold;">S DTIC ELECTE D</p> <p style="font-size: 1.5em; font-weight: bold;">MAR 22 1983</p> <p style="font-size: 1.5em; font-weight: bold;">B</p> <p style="font-size: 1.5em; font-weight: bold;">83 03 04 083</p> </div> </div> | | | | | |
| 17. Key Words | | | 18. Distribution Statement Document is available to the public through the National Technical Information Service, Springfield, Virginia 22161 | | |
| 19. Security Classif. (of this report) | | 20. Security Classif. (of this page) | | 21. No. of Pages 301 | 22. Price 211 |

The contents of this report reflect neither a position nor an official policy of the Department of Transportation. This document is disseminated in the interest of information exchange. The United States Government assumes no liability for the contents of this document or use thereof.

| | |
|--------------------|-------------------------------------|
| Accession For | |
| NTIS GRA&I | <input checked="" type="checkbox"/> |
| DTIC TAB | <input type="checkbox"/> |
| Unannounced | <input type="checkbox"/> |
| Justification | |
| PER LETTER | |
| By | |
| Distribution/ | |
| Availability Codes | |
| Dist | Avail and/or Special |
| A | |

DTIC
COPY
INSPECTED
2

TABLE OF CONTENTS

| | <u>Page</u> |
|--|-------------|
| GLOSSARY | i |
| PREFACE | 1 |
| <u>APPENDIX A</u> NATIONAL AIRSPACE DATA INTERCHANGE NETWORK AND VOICE SWITCHING AND CONTROL SYSTEM | A-1 |
| A. FAA Services Consolidated in NADIN I | A-2 |
| B. NADIN Structure | A-8 |
| C. NADIN I Subscribers And Their Links | A-11 |
| D. NADIN I System Capabilities | A-13 |
| E. Hardware Elements (Switching Centers, Modems, Circuits, and Principal Terminals) | A-14 |
| F. Maintenance/Realibility | A-21 |
| G. Milestones and Enhancement Plans | A-24 |
| <u>APPENDIX B</u> COLLISION AVOIDANCE SYSTEMS | B-1 |
| I. GENERAL BACKGROUND | B-1 |
| A. Description Of The Problem | B-2 |
| B. Historical Perspective | B-7 |
| C. Increases in General Aviation | B-10 |
| D. Human Factors | B-14 |
| II. AIRCRAFT SEPARATION ASSURANCE PROGRAM | B-16 |
| A. Terminal Conflict Alert Function of Air Traffic. Control | B-17 |
| B. Conflict Avoidance Systems | B-17 |
| III. NEAR-TERM AUTOMATION PROGRAMS | B-19 |
| A. The Automated Terminal Service (ATS) | B-20 |
| B. The Automated En Route Air Traffic Control (AERA) System | B-28 |
| C. Non-Flight Plan Based System | B-29 |
| D. FAA Ground Based Separation Programs - Conflict Alert | B-30 |
| IV. AIR TRAFFIC CONTROL RADAR BEACON SYSTEM (ATCRBS) AND DISCRETE ADDRESS BEACON SYSTEM (DABS) | B-31 |
| A. ATCRBS System | B-33 |
| B. DABS System | B-34 |

| | | |
|-------------------|--|-------|
| V. | ALGORITHMS FOR CONFLICT AVOIDANCE SYSTEMS | B-35 |
| | A. Types of Algorithms | B-35 |
| | B. Primary Threat Criteris | B-37 |
| | C. Altitude Criteris | B-39 |
| VI. | INITIAL CAS DEVELOPMENT BY FAA | B-39 |
| | A. McDonnell Douglas Electronics Company (MDED) . . | B-40 |
| | Time/ Frequency CAS | |
| | B. Honeywell - Collision Avoidance System | B-46 |
| | C. RCA SECANT Equipment VECAS and VECAS-GA | B-52 |
| | D. Mitre CAS | B-58 |
| | E. Litchford CAS | B-59 |
| | F. Sierra Research Corporation CAS | B-66 |
| | G. Miscellaneous System | B-67 |
| VII. | FAA BEACON BASED COLLISION AVOIDANCE SYSTEM (BCAS) . | B-69 |
| | A. BCAS Technical Description | B-70 |
| | B. "Whisper-Shout" Technique | B-72 |
| | C. "Squitter" Messages | B-73 |
| | D. Passive Mode | B-73 |
| | E. Semiactive BCAS | B-74 |
| | F. BCAS Display Capability | B-75 |
| | G. Phases of Development of FAA BCAS | B-75 |
| | H. The National BCAS Standard | B-81 |
| | I. The Modes of BCAS Operation With ATCRBS And . . | B-86 |
| | DABS | |
| VIII. | AUTOMATIC TRAFFIC ADVISORY AND RESOLUTION SERVICE . | B-92 |
| | (ATARS) | |
| | A. Intermittent Positive Control | B-92 |
| | B. Traffic Advisory Service Development | B-99 |
| | C. Resolution Service Development | B-100 |
| | D. Flight Test Results on IPC Algorithm | B-101 |
| | E. The FAA Technical Approach | B-103 |
| IX. | CAS MILESTONES | B-104 |
| X. | CONCLUSION | B-104 |
| | | |
| <u>APPENDIX C</u> | INTERCOM/INTERPHONE SYSTEMS AND VOICE COMMUNICA- | C-1 |
| | TIONS SYSTEM | |
| I. | SYSTEM BACKGROUND AND STRUCTURE | C-1 |
| | A. Electronic Voice Switching (EVS) System | C-7 |
| | B. Integrated National Airspace Communication . . . | C-11 |
| | System (INACS) | |

| | | |
|-------|--|-------|
| II. | SYSTEM APPLICATIONS | C-19 |
| | A. The Central Flow Control Facility | C-22 |
| | B. Air Route Traffic Control Center (ARTCC) | C-22 |
| | C. Air Traffic Control Towers (ATCT) | C-24 |
| | D. Control Towers and IFR Room (ATCT/TRACON) | C-24 |
| | E. Flight Service Stations (FSS) | C-25 |
| | F. Combined Station/Tower (CS/T) | C-26 |
| III. | WECO 300 SWITCHING SYSTEM | C-27 |
| | A. Operational Features | C-29 |
| | B. Equipment Description | C-33 |
| IV. | WECO 301 SWITCHING SYSTEM | C-41 |
| | A. Operational Features | C-42 |
| | B. Equipment Description | C-46 |
| V. | WESCOM 920 KEY SYSTEM | C-58 |
| | A. Operational Features | C-58 |
| | B. Equipment Description | C-60 |
| VI. | SMALL KEY SYSTEMS | C-66 |
| | A. Operational Features | C-69 |
| | B. Equipment Description | C-71 |
| VII. | CALL DISTRIBUTION UNITS | C-72 |
| | A. Operational Features | C-73 |
| | B. Equipment Description | C-74 |
| VIII. | TERMINAL COMMUNICATIONS SWITCHING SYSTEM | C-77 |
| | A. Operational Features | C-80 |
| | B. Equipment Descriptions | C-84 |
| IX. | WECO 304 CONFERENCE SWITCHING SYSTEM | C-94 |
| | A. Operational Features | C-95 |
| | B. Equipment Description | C-99 |
| X. | SUPPORT PBX FOR ADMINISTRATION AND MAINTENANCE | C-100 |
| XI. | FUTURE FAA SWITCHING SYSTEMS | C-106 |
| | A. Small Voice Switching System (SVSS) | C-107 |

| | | |
|-------|--|-------|
| XII. | VOICE SWITCHING AND CONTROL SYSTEM | C-119 |
| XIII. | THE NAFEC COMMUNICATION SWITCHING SYSTEM | C-120 |
| | A. Operationsl Features | C-121 |
| | B. Technical Equipment | C-122 |
| | C. Position Equipment | C-126 |
| | D. Backroom Equipment | C-127 |
| | E. The Common Control Subsystem | C-127 |
| XIV. | CONCLUSION | C-129 |

TABLE OF FIGURES

| | | <u>Page</u> |
|-------|---|-------------|
| A-1 | Existing Configuration of Proposed NADIN I | A-4 |
| A-2 | Addition of NADIN I System and AFTN/SMSC/ACE/ NWS Interfaces | A-5 |
| A-3 | NADIN I ARINC/Airline Requirements | A-6 |
| A-4 | NADIN Backbone Network | A-9 |
| A-5 | NADIN Implementation | A-10 |
| A-6 | NADIN | A-12 |
| A-7 | NADIN Switch Functional Block Diagram | A-18 |
| A-8 | NADIN I Concentrator Functional | A-18 |
| A-9 | Planned Evolvement of Initial NADIN into the Communications Subsystem of the National Airspace System | A-25 |
| A-10 | Uncombined RCCS/VCS | A-35 |
| A-11 | Combined RCCS/VCS | A-38 |
| | | |
| B-1B | 1982 Baseline System Airspace Structure | B-3 |
| B-2B | 1975 Flight Standards Near Mid-Air Collision (NMAC) Reports | B-5 |
| B-3 | Projected Air Traffic Parameters | B-11 |
| B-4 | A Comparison of Aviation Forecasts | B-12 |
| B-5A | Instrument Operations at Airports with FAA Traffic Control Service, Fiscal Years 1973-1990. | B-13 |
| B-6 | Artist's Conception of an Automated Terminal Services Site | B-21 |
| B-7 | ATS Service Regions | B-23 |
| B-8 | Elements for Automated Terminal Service | B-25 |
| B-9 | Conflict Alert Concepts | B-32 |
| B-10 | Conflict Alert Concepts | B-32 |
| B-11 | Commercial Airline CAS Configuration | B-44 |
| B-12 | Interrogation/Response Sequence of Events | B-48 |
| B-13 | Timing Diagram for Interrogate/Response Sequence | B-49 |
| B-14 | BCAS Separation Assurance Display | B-61 |
| B-15 | What is BCAS and How Does it Work? | B-62 |
| B-16A | ATCRBS Network | B-64 |
| B-16B | BCAS Message Reply Sequence | B-64 |
| B-17 | RCAS Operational Use of Differential Azimuths | B-65 |
| B-18 | BCAS Concept | B-71 |
| B-19 | Baseline CAS Display | B-76 |
| B-20 | Active Mode BCAS System Block Diagram | B-84 |
| B-21 | BCAS/ATCRBS Mode | B-87 |
| B-22 | BCAS/DABS Mode | B-90 |

| | <u>Page</u> |
|------|---|
| B-23 | Alternative IPC Displays B-94 |
| B-24 | ATARS Traffic and Resolution Advisories B-96 |
| B-25 | BCAS Program and Development Deadlines B-10 |
| B-26 | 1990 BCAS Requirements B-10 |
| B-27 | DABS Development Program Schedule B-10 |
| B-28 | ATARS Program Schedule B-10 |
| | |
| C-1 | FAA Air Traffic System C-2 |
| C-2 | FAA Communications Network C-3 |
| C-3 | FAA Telecommunications Subnetwork Based on ARTCC C-4 |
| C-4 | EVS System Environment - Initial Configuration C-9 |
| C-5 | EVS System Environment - Final Configuration C-10 |
| C-6 | INACS Hierarchy Concept C-13 |
| C-7 | Voice Communications Subsystem Elements and Functions C-18 |
| C-8 | Conceptual Block Diagram of the WECO 300 SS C-28 |
| C-9 | Functional Diagram of the WECO 300 SS C-34 |
| C-10 | Representative Terminations by Circuit Type To/From ARTCC C-35 |
| C-11 | 300 SS Simplified Functional Diagram C-38 |
| C-12 | Coordinate Representation Crosspoints Matrix C-40 |
| C-13 | Representative Terminations by Circuit Type To/From ATCT C-47 |
| C-14 | Representative Terminations By Circuit Type To/From ATCT/TRACON C-48 |
| C-15 | TELCO Type 301 Switching System, Simplified Block Diagram C-56 |
| C-16 | FAA to TELCO Interface Points, 301 SS C-56 |
| C-17 | Functional Block Diagram of a WESCOM 920 Installation C-59 |
| C-18 | WESCOM 920 Modular Tower Package System, Block Diagram C-61 |
| C-19 | WESCOM 920 12-Line Console Layout C-64 |
| C-20 | WESCOM 920 Backroom Equipment C-67 |
| C-21 | WESCOM 02- Strapping Field C-68 |
| C-22 | Subsystem Distribution C-86 |
| C-23 | TCSS Installation on Horizontal Displays in Tracon C-90 |
| C-24 | WECO 304 Conference Switching System Block Diagram C-96 |
| C-25 | Transmission Plan Adopted for the 304 SS C-98 |
| C-26 | Small Voice Switching System (SVSS) Simplified Block Diagram C-11 |
| C-27 | NCSS Block Diagram C-12 |

TABLE OF TABLES

| | | <u>Page</u> |
|------|--|-------------|
| A.1 | NADIN I Interface | A-7 |
| A.2 | NADIN Development Schedule | A-26 |
| | | |
| B.1 | CAS Equipment Description Summary | B-42 |
| | | |
| C.1 | IC/IP Network Termination Facilities | C-20 |
| C.2 | FAA Voice (IC/IP) Communications Network Connectivity | C-21 |
| C-2A | Circuit Type Codes | C-36 |
| C.3 | Key and Switching Equipment at FAA Facilities | C-70 |
| C.4 | Specification of the Most Commonly Used WECO PBX For FAA Administrative/Maintenance Use | C-103 |
| C.5 | System Capacity and Modularity | C-123 |

GLOSSARY

GLOSSARY

| | |
|--------|---|
| ACAS | Airborne Collision Avoidance System |
| ADF | Automatic Direction Finder |
| ADIS | Automatic Data Interchange System |
| ADS | Alpha-numeric Display System |
| AFS | Aeronautical Fixed Service |
| AFTN | Aeronautical Fixed Telecommunications Network |
| AID | Airport Information Desk |
| AIREP | Air Report |
| ALS | Approach Lighting System |
| AMIS | Aircraft Movement Information Service |
| API | Air Position Indicator |
| ARINC | Aeronautical Radio, Inc. |
| ARSR | Air Route Surveillance Radar |
| ARTCC | Air Route Traffic Control Center |
| ARTS | Automated Radar Terminal System |
| ASDE | Airport Surface Detection Equipment |
| ASR | Airport Surveillance Radar |
| ATA | Air Transport Association |
| ATARS | Automatic Traffic Advisory Resolution Service |
| ATC | Air Traffic Control |
| ATCRBS | Air Traffic Control Radar Beacon System |
| ATCSCC | ATC Systems Command Center |
| ATCT | Airport Traffic Control Tower |
| ATIS | Automatic Terminal Information Service |
| | |
| BASOPS | Military Base Operations |
| BCAS | Beacon Collision Avoidance System |
| BUEC | Backup Emergency Communications |
| | |
| CAS | Collision Avoidance System |
| CCC | Central Computer Complex |
| COMSAT | Communications Satellite Corporation |
| CRT | Cathode-Ray Tube |
| CST | Combined Station/Tower |
| | |
| DABS | Discrete Address Beacon System |
| DCS | Data Communication System |
| DF | Direction Finder |
| DME | Distance Measuring Equipment |
| | |
| EFAS | En Route Flight Advisory Service |
| EPI | Expanded Position Indicator |
| ESS | Electronic Switching Systems |
| EVSS | Electronic Voice Switching System |

| | |
|--------|---|
| FAA | Federal Aviation Administration |
| FAR | Federal Aviation Regulations |
| FAWS | Flight Advisory Weather Service |
| FDEP | Flight Data Entry and Printout Equipment |
| FDP | Flight Data Processing |
| FIPS | Federal Information Processing Standard |
| FSS | Flight Service Station |
| GA | General Aviation |
| GPWS | Ground Proximity Warning System |
| HDTA | High Density Terminal Area |
| HF | High Frequency |
| Hz | Hertz (cycles per second) |
| IC | Intercom |
| ICAO | International Civil Aviation Organization |
| IFR | Instrument Flight Rules |
| IFSS | International Flight Service Station |
| ILS | Instrument Landing System |
| IP | Interphone |
| ISLS | Improved Sidelobe Suppression |
| KHz | Kilohertz |
| LF | Low Frequency |
| LINS | Laser Inertial Navigation System |
| LPLO | Limited Range Communication Outlet |
| LRR | Long-Range Radar |
| MF | Medium Frequency |
| MFS | Military Flight Service |
| MHz | Megahertz |
| MLS | Microwave Landing System |
| MSAW | Minimum Safe Altitude Warning System |
| MWTCS | Modernized Weather Teletypewriter Communication Service |
| NAFEC | National Aviation Facilities Experimental Center |
| NADIN | National Airspace Data Interchange Network |
| NAS | National Airspace System |
| NASA | National Aeronautics and Space Administration |
| NATCOM | National Communications Center |
| NAVAID | Air Navigation Facility |
| NFDC | National Flight Data Center |
| NOTAM | Notice to Airmen |

| | |
|--------|---|
| PARWAS | Pilot Automatic Transcribed Weather Answering Service |
| PIREP | Pilot Report |
| | |
| RAPCON | Radar Approach Control |
| RATCF | Radar Air Traffic Control Facility |
| RCS | Radio Communication System |
| RCCS | Radio Communication Control System |
| RCTA | Radio Technical Commission for Aeronautics |
| RFP | Request for Proposal |
| RTR | Remote Transmitter/Receiver Facility |
| RMM | Remote Maintenance Monitoring |
| RCAG | Remote Center Air/Ground Communication Facility |
| RCO | Remote Communications Outlet |
| RML | Radar Microwave Link |
| RNAV | Area Navigation |
| | |
| SAR | Search and Rescue |
| SECRA | Secondary Radar |
| SFO | Single Frequency Outlet |
| SLS | Sidelobe Suppression Beam |
| SPAN | Stored Program Alpha-Numeric Project |
| S/R | Send/Receive |
| SSF | System Support Facility |
| SVSS | Small Voice Switching System |
| | |
| TACAN | Tactical Air Navigation |
| TELCO | Telephone Company |
| TDP | Technical Data Package |
| TRACON | Terminal Radar Approach Control |
| TRSB | Time Reference Scanning Beacon |
| TWEB | Transcribed Weather Broadcast Service |
| | |
| UHF | Ultra High Frequency |
| | |
| VCS | Voice Communication System |
| VF | Voice Frequencies |
| VFR | Visual Flight Rules |
| VHF | Very High Frequency |
| VOR | Very High Frequency Omnidirectional Range |
| VORTAC | (see VOR and TACAN) |
| VSCS | Voice Switching Control System |
| | |
| WATS | Wide Area Telephone Service |
| WFCO | Western Electric Company |
| WMSC | Weather Message Switching Center |

PREFACE

PREFACE

Phase I of the study to provide a Socioeconomic Assessment of the Communications Industry is concerned with establishing the historical and current context which forms the basis for the technology forecast and assessment to be conducted in Phases III and IV.

Volume I of the Phase I report, "Description and Documentation of the Current State-of-the-Art", provides that basis along several important dimensions. It traces the role of communications in aviation from the days of the Wright Brothers to the present. Aviation communication systems have been classified into three categories: Radio Communications System (RCS), Voice Communications System (VCS), and Data Communications System (DCS). Finally, current equipment and subsystems have been described, as well as those likely to be implemented by 1985.

What remains to be accomplished is the detailed technical description of current and near-term future systems and equipment. The appendices in this volume provide those descriptions, as well as other material which may be of interest to a more limited audience than the material presented in Volume I. The system descriptions contained in this volume differ from those in Volume I along two dimensions. First, the previous system descriptions

were functional in nature, and were primarily concerned with system requirements, performance and interconnections. These descriptions, while touching on all of these aspects, placed more emphasis on the design criteria and hardware of the systems and subsystems. Secondly, while Volume I was primarily concerned with current and near-term future systems, this volume will more fully describe the historical and evolutionary development of the systems. As such, it will compliment the material in Chapter Four of Volume I, which assessed innovation and diffusion.

The material in this volume is divided into three appendices. Appendix A describes the integration of several DCS and VCS functions into the proposed National Airspace Data Interchange Network (NADIN). Appendix A also describes work in progress on the Voice Switching and Control System (VSCS). Appendix B describes the evolution and current state-of-the-art for Collision Avoidance Systems. Finally, Appendix C supplements the material presented in Volume I on the Intercom/Interphone (IP/IC) systems, and Appendix A regarding VCS.

Acknowledgement is given to AMAF Industries, Incorporated of Columbia, Maryland (subcontractor) for conducting the research which formed the basis for the information presented in the Appendices.

APPENDIX A

NATIONAL AIRSPACE DATA INTERCHANGE NETWORK

AND

VOICE SWITCHING AND CONTROL SYSTEM

NATIONAL AIRSPACE DATA INTERCHANGE NETWORK (NADIN)

NADIN will be an integrated, digital data communications system implemented as a ground-to-ground digital message switching network. It will consolidate separate low speed data service existing presently into more efficient and economical systems. NADIN will be implemented in well defined independent, discrete, manageable stages to provide comprehensive support to domestic and international air movement activities [1] [2] .

Over the past decades, the FAA has created a number of entirely separate, low speed data services for collection and dissemination of various categories of information to and from its facilities. Each of these services is applied to a specific area, and suffers from obsolescence, limited expansion capability, and high operation and maintenance costs. In addition, intercommunication between these networks is not possible since common standards or procedures do not exist and therefore cannot be combined to meet NAS present or future communication requirements. Any upgrading or improvement of the existing network would not be cost effective. The salient deficiencies of today's discrete record transfer networks are:

- o Excessive circuit cost
- o Obsolete equipment which is difficult to maintain
- o Operation and maintenance are labor intensive

- o Incompatible formats and procedures
- o Inadequate network management

In the early 1970's, the FAA conceived NADIN as a fully amalgamated, state-of-the-art ground-to-ground data network to meet total projected requirements of Air Traffic Control.

Economic studies prove that a combined FAA network, integrating various existing diverse networks, will be more efficient, cost-effective, easily expandable and versatile. The system will be a multi-user message network, initially replacing a number of inefficient, discrete low speed networks and switching systems. NADIN will establish uniformity of equipment and procedures and gain an ample margin of capacity and performance for current data communication requirements, with capability for growth to accommodate future needs.

A. FAA Services Consolidated In NADIN I

In DOT specification FAA-E-2661, the following services are designated for incorporation into the NADIN I network configuration:

- o Area B, Supplemental B and NAS/BDIS
- o Center B
- o Utility B (Category 1 and 2)
- o NASNET
- o NAS/WMSC

o AFTN (National and International)

NADIN is designed to receive, process, and transmit digital data (at various speeds, codes, and formats) handled by the above telecommunication (record) systems. The existing configuration of proposed NADIN I users is shown in Figure A-1. The effect of introduction of NADIN I to the existing configuration is seen in Figure A-2. The interface with NAS/WMSC and ARINC/AIRLINE is shown in Figure A-3.

The NADIN system will interface a number of FAA and other record transfer data networks, through asynchronous/synchronous links, which may be character or bit oriented; shown in Table A.1. This will allow NADIN to perform a wide range of data services in the form of a complete message transfer capability. Furthermore, NADIN to the Dial-up Terminal interface shall employ X3.28 sub 2.5 or the Bell System 85A2 link control procedure in the NADIN format. A Binary Synchronous communication interface will be thru 2400/4800 b/s synchronous modems, and require a Type 3000 private 4-wire circuit per FCC Tariff No. 260. An Interface will also be provided between a NADIN node or terminal and the Bell System Digital Data System (DDS), as an alternative method to analog communications facilities by obtaining transmission facilities for the communications of digital data. A DSU (which converts EIA-RS-232 or CCITT V.35 interface signals to bipolar line signals and vice versa) shall provide 2.4, 4.8 or 9.6 kb/s service to the

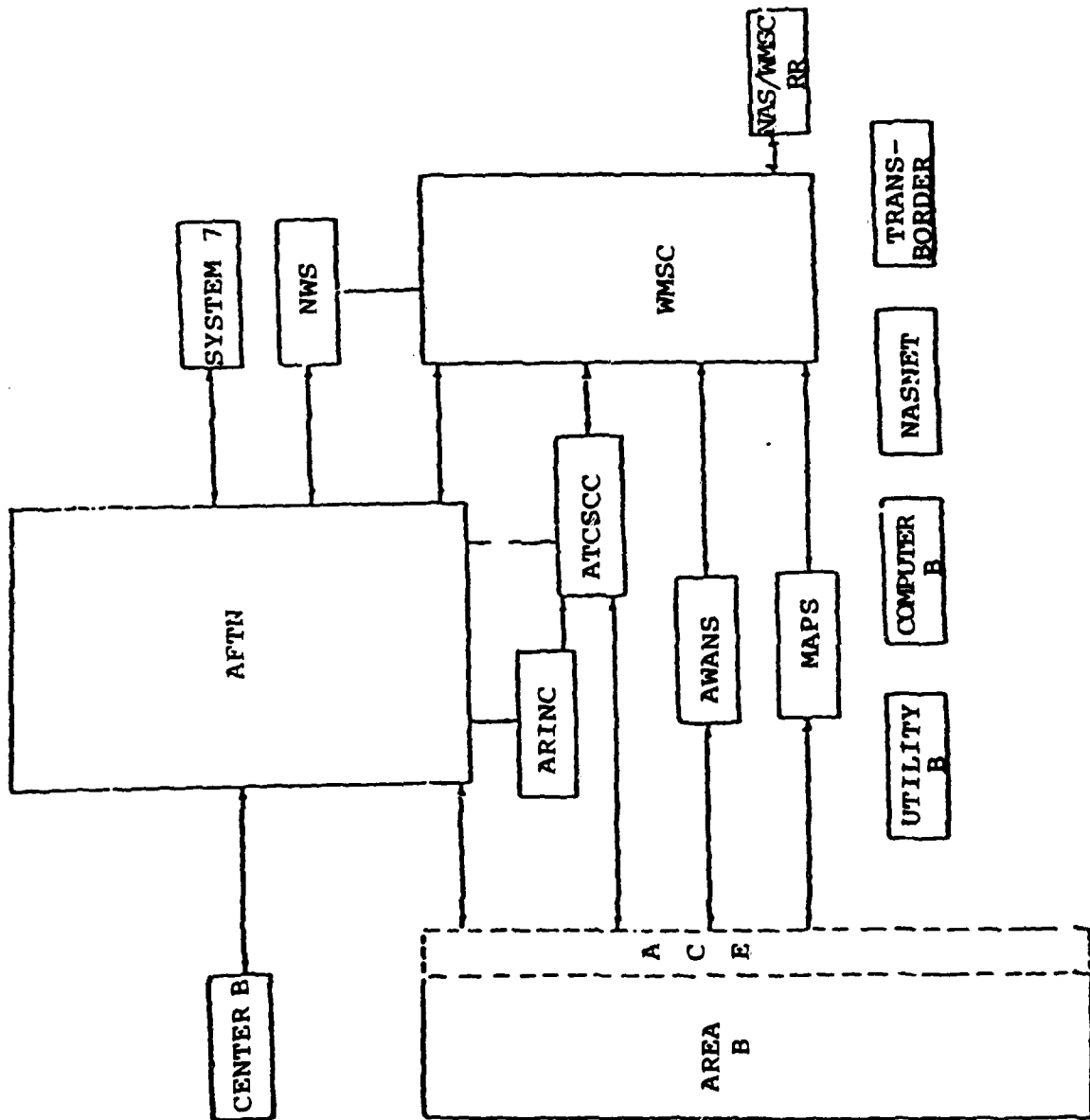

EXISTING CONFIGURATION OF PROPOSED NADIN I

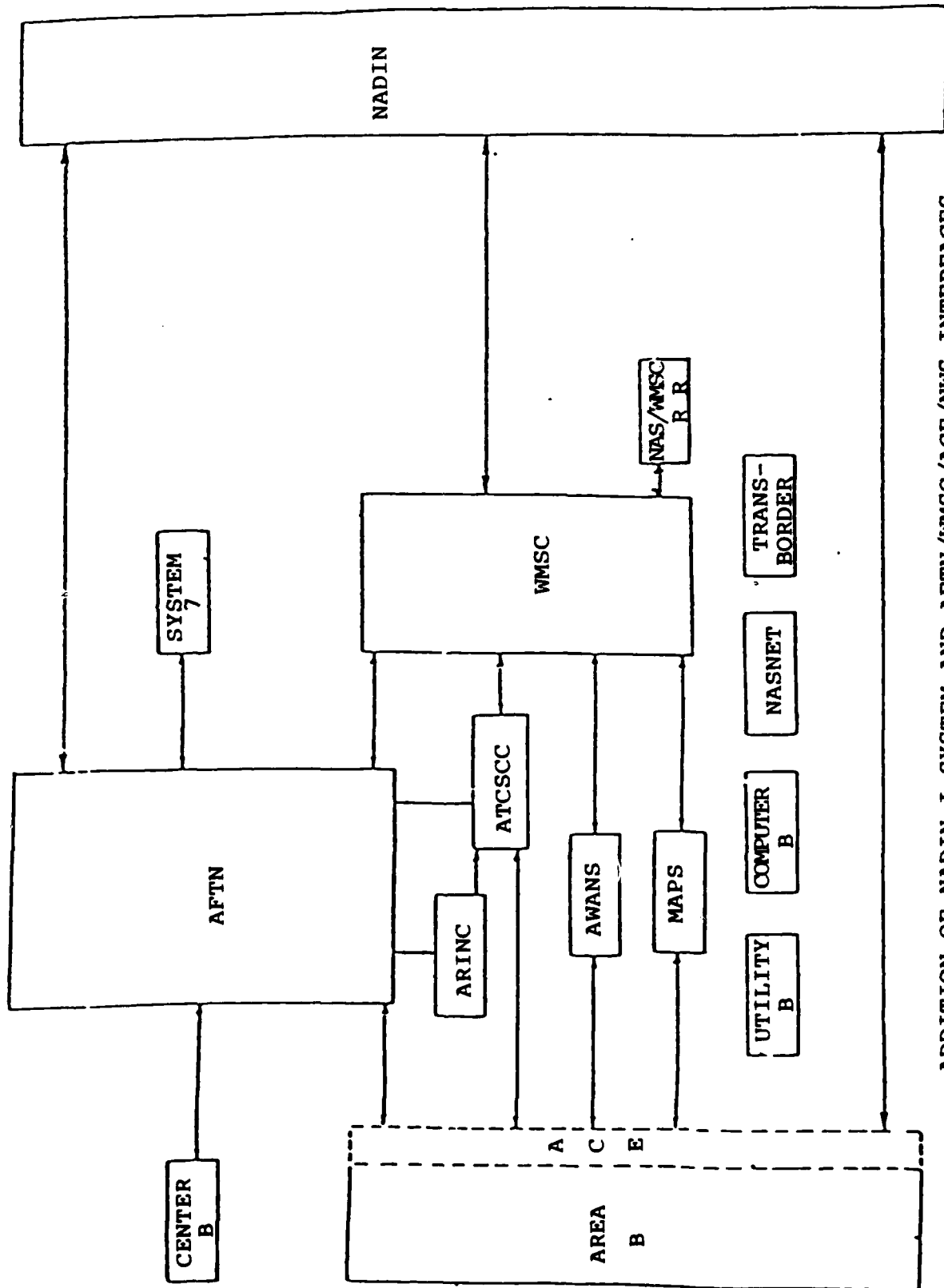

ADDITION OF NADIN I SYSTEM AND AFTN/WMSC/ACE/NWS INTERFACES

Figure A-2

(NOTE: It is assumed all special/interim interfaces will

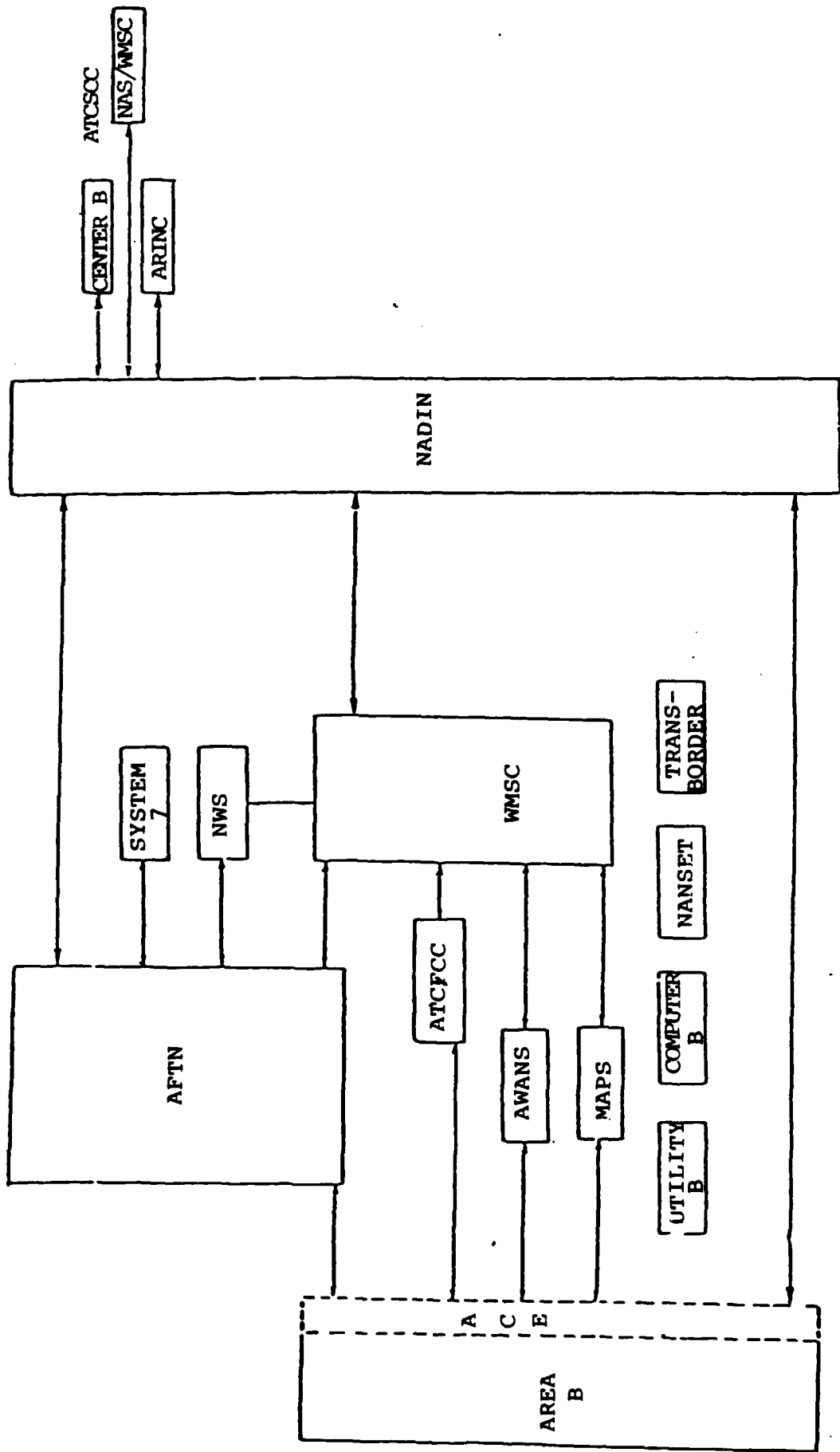

NADIN I ARINC/AIRLINE REQUIREMENTS

FIGURE A-3

FIGURE A-3

NADIN I INTERFACES

DATA NETWORK

BASIC INTERFACE

| | |
|------------------------|---|
| NAS 9020 | A 9-bit byte (8 bits of data with one bit of parity), bit parallel, asynchronous link at variable speeds up to 40,000 bytes per second. Both the NADIN concentrator and the NAS 9020 effect control over the effective transfer rate. |
| WMSC | A bit-serial, synchronous, two-way simultaneous link at speeds up to 4800 b/s. |
| NWS | A bit-serial, synchronous, two-way simultaneous link at speeds up to 2400 b/s. |
| Flow Control Processor | A synchronous 4-wire communications link at speed of 4800 b/s with an upgrade capability to 9600 b/s with dial back-up when required. |
| BDIS | Bit-serial, asynchronous, two-way alternate links at 1200 b/s. |
| Non-US AFTN | Selected from one of the TTY or medium-speed interfaces defined within NADIN specifications. The control of the interface shall also provide all necessary formats, code conversion, message accountability, and processing required by the appropriate ICAO Documents. |
| AWANS & MAPS | Bit-serial, asynchronous, 1200 b/s, two-way alternate links employing ANSI X.3.28 Subcategory 2.5 or 2.7 procedures. These interfaces shall be capable of being modified to two-way simultaneous synchronous procedures. |
| ARINC | Bit-serial, synchronous, two-way simultaneous link employing ANSI X.3.28 procedures. |
| ICAO | To other national communications centers of the ICAO network shall conform to either: <ol style="list-style-type: none">(1) Annex 10, Volume II character oriented procedures, or(2) CIDIN high level procedures |
| AFTN | 75 b/s Baude, 60 ma neutral mode circuits up to 200 V DC open circuit voltage. |

Table A-1

data terminal equipment in accordance with EIA Standard RS-232, interface Type D or Type E. In addition, the data and clock signals shall conform to EIA Standard RS-334 for synchronous channels. Additional interfaces will be developed to handle future communication requirements as they are defined.

B. NADIN Structure

The NADIN system will consist of a nationwide, low speed message switching network. The network backbone links will be as shown in Figure A-4. There will be two Message Switches, located at the FAA ARTCC facilities in Salt Lake City, Utah and Atlanta, Georgia. There will be a number of concentrators, on located at each ARTCC, (including units co-located with the two exchanges and at Anchorage, Honolulu and San Juan).

There will be a number of data communication terminals tied to a local concentrator which will control the terminals including the NAS 9020 computer terminals. The concentrators will be inter-connected to the two Message Switching Centers, each of which will be capable of individually and independently managing and providing service to the entire network. A block diagram of such an inter-connected structure of elements constituting the NADIN and FAA facilities/units terminating at NADIN is shown in Figure A-5. The NADIN System will be capable of interface through all kinds of transmission media including satellites for domestic and international communication. The speeds of the data transmission

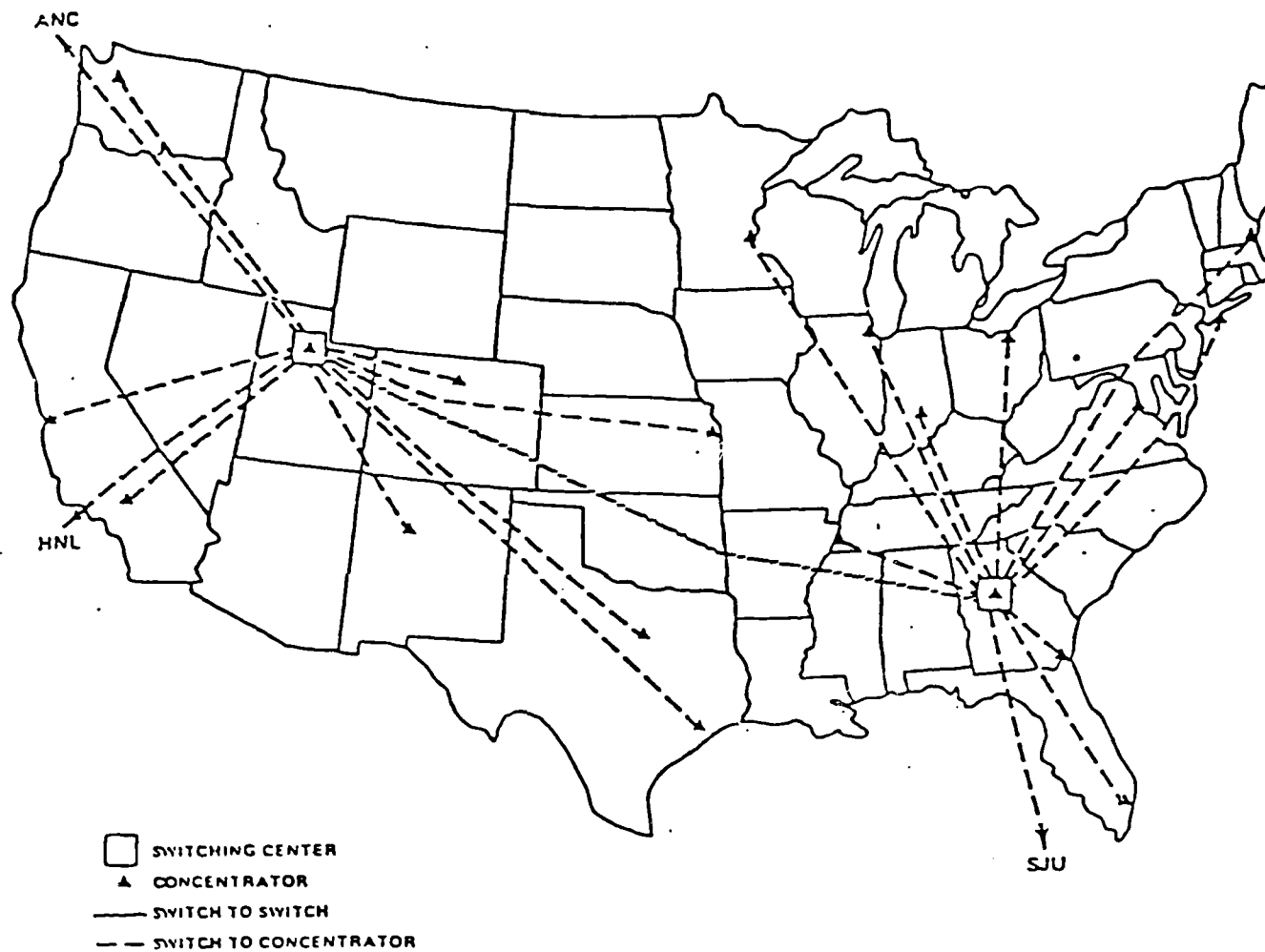

NADIN BACKBONE NETWORK

FIGURE A-4

NADIN IMPLEMENTATION

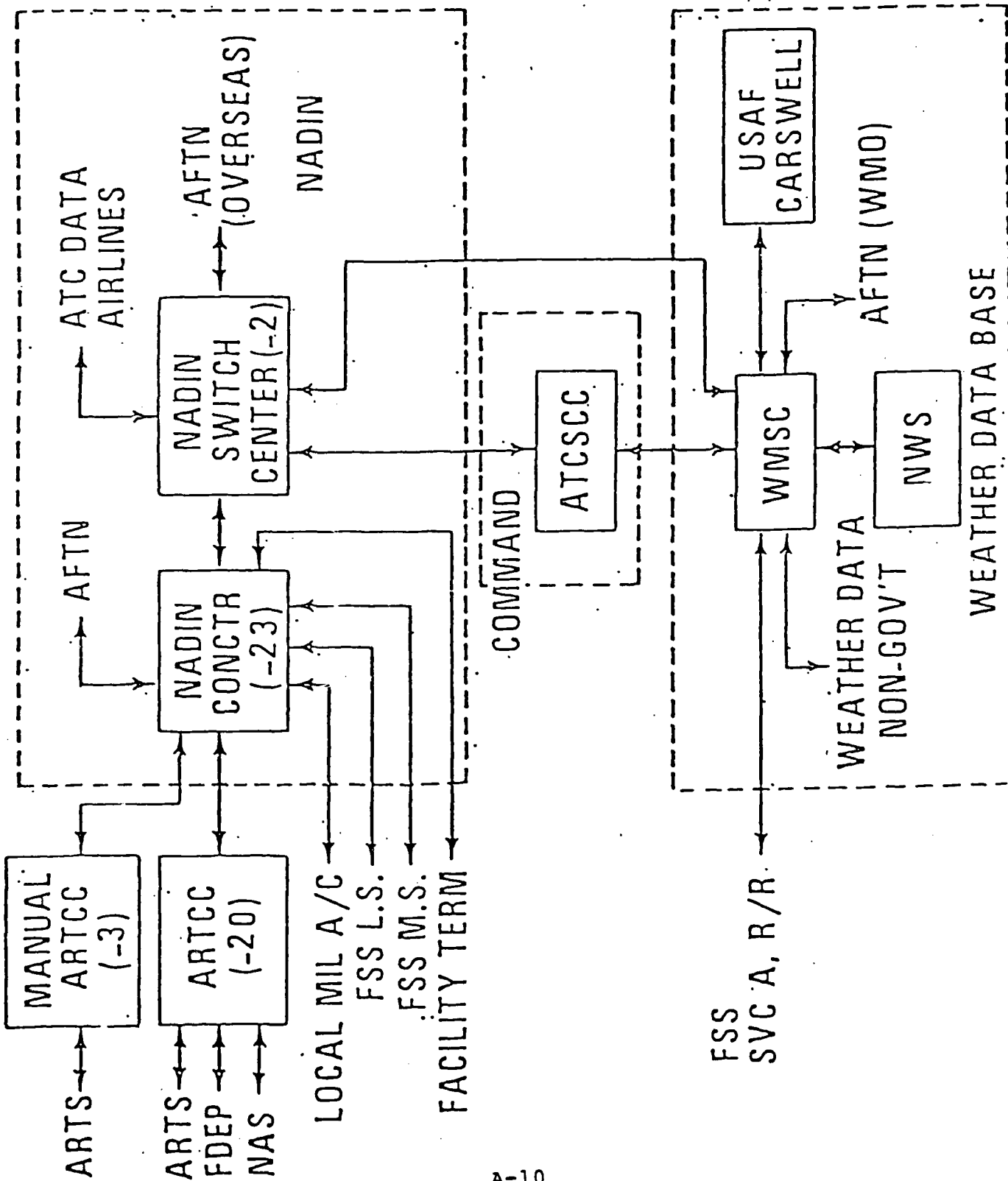

links linking the hierarchy of the NADIN network is shown in Figure A-6.

Any and all messages initiated at a terminal arrive at one of the Message Switching Centers, through concentrators, and are delivered to the desired destinations. To allow a follow-up in case of a lost or garbled message, these switches also perform a Data Journalling function. They also maintain complete statistics on the traffic handled, making available continuous information on network demand and capability. It pinpoints underutilized circuits and areas becoming congested and implements dynamic trunk supervision for optimal utilization.

The NADIN System has been designed to eliminate any and all hardships on the user of an existing service, who will find the new system transparent, requiring no changes to presently used standard protocols or practices.

C. NADIN I Subscribers And Their Links

A variety of subscriber terminals are served by the NADIN I system including:

- o Low speed teleprinter (e.g., Model 28 Teleprinters)
 - terminated on polled multi-point circuits from NADIN concentrators
- o Medium speed terminals (e.g., DTES)
 - served through dedicated links to the NADIN concentrators using message/block oriented procedures.

NADIN

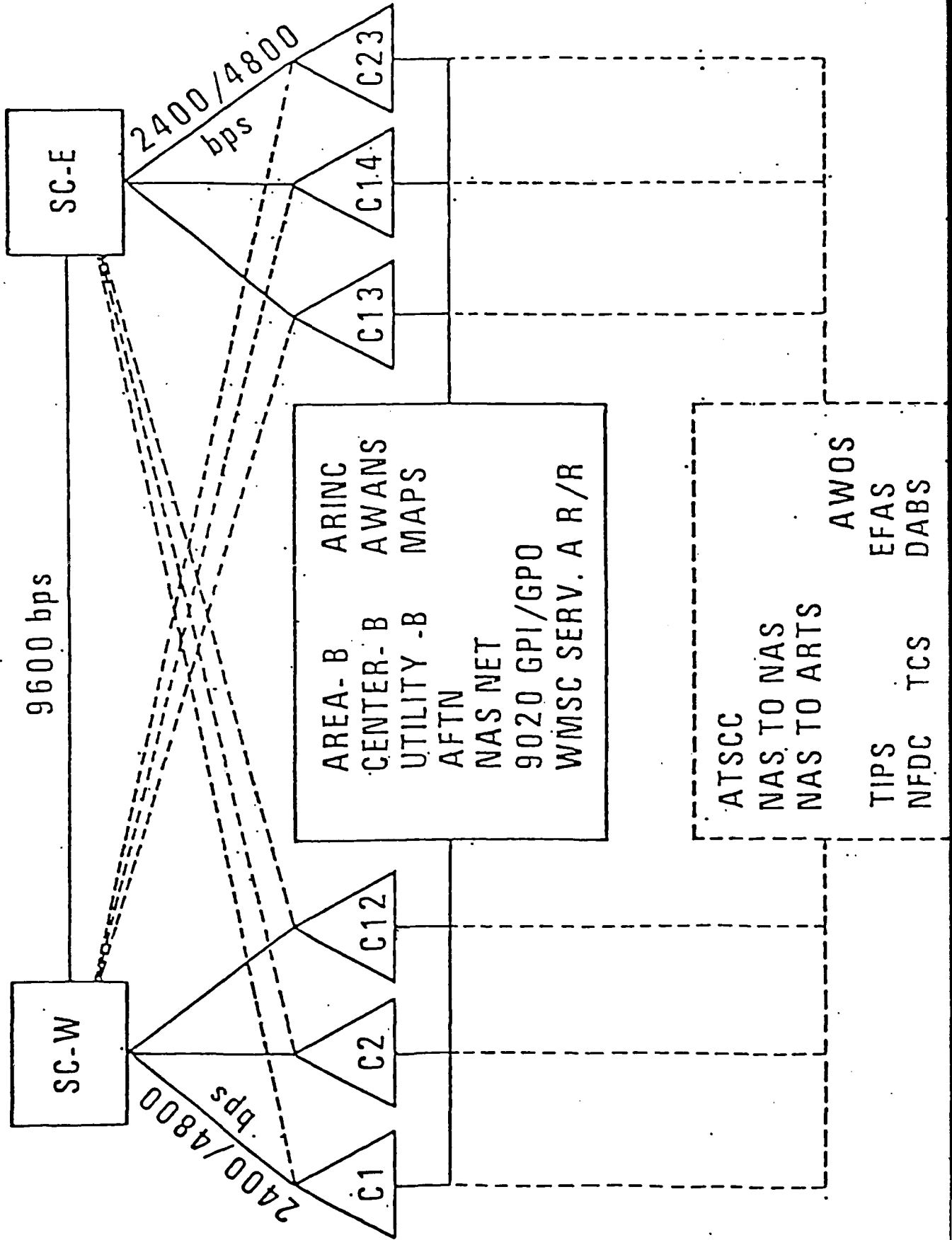

- o Computers (e.g., WMSC DS-714 and NAS 9020)
 - the DS-714 is served similarly to medium speed terminals while the NAS 920 computers require a special interface to the concentrator.

It is pertinent to point out that the links for transfer of information between switches and switch/concentrators will be on a frame by frame basis. The frames of multi-frame messages, although transmitted in proper sequence, are interspersed with frames of other messages. The node serving the destination access line separates the frames of a given message from the other message frames mingled among them to transmit over the destination access line, either continuously, as in the low-speed case, or as individual frames in the case of access lines using message-oriented blocking.

D. NADIN I System Capabilities

The NADIN I system will be designed and implemented to provide the following capabilities:

- o Transfer of all messages presently being handled by the FAA Service B network (Area, Supplemental, Utility B, Center B, and NASNET).
- o Transfer of all messages presently being handled by the FAA controlled portion of AFTN, to be referred to herein as the National AFTN.
- o Interface and communication with, but not limited to, the Weather Message Switching Center (WMSC), Common ICAO Data Interchange Network (CIDIN), Aviation Weather and NOTAM System (AWANS), Central Flow Control, Air Carrier Communication Systems, National Weather Service (NWS), Suitland, Meteorological and Aeronautical Presentation

System (MAPS), and the international Aeronautical Fixed Telecommunications Network (AFTN).

E. Hardware Elements (Switching Centers, Modems, Circuits, And Principal Terminals)

The NADIN I system will consist of a number of hardware elements i.e.:

- o Switching Centers
- o Concentrators
- o Modem
- o Circuits
- o Special Interface Services
- o Terminals

These hardware elements will be designed to improve collection of ATC statistical data from field facilities and to allow systematic growth for the handling of aircraft movement and control data.

Other requirements demand:

- o Readily implemented hardware and software functions to handle all projected traffic volumes and data services.
- o Throughput and delay factors within the limits stated within this specification.
- o Highly reliable operation, with easily maintained components as further defined within this specification.
- o Monitoring its elements and detecting its failures, and automatically responding to its failures.
- o Online monitoring and recording of operational data that will provide information on system throughput, message volumes, message distribution, status of nodes, links, and queuing delays.

These hardware elements are briefly described in the following subsections:

1. The Switching Centers

Two Message Switching Centers (SC) will be employed in NADIN I structure, one located at Salt Lake City, Utah and the other at Atlanta, Georgia. These will be state-of-the-art exchanges based on a computer with greater input/output capability than data manipulation/calculation strengths, and with modest program/data-file-storage capacities. Thus, relatively small units of core memory for primary storage and disk/drum/tape based secondary storage will be required and a substantial number of communication circuits for input/output channels.

The Message Switching Center will be of a store-and-forward type, which will perform the message processing in the following conventional steps:

- o Acknowledgement to Originator
- o Recording
- o Format Check and Edit
- o Routing
- o Code and Format Conversion
- o Output

The switching centers will control data flow throughout

the network. Data flow between terminals shall be via the appropriate concentrators and switching centers with all routing and accountability being handled by the switching centers. Messages handled by the network will have the option, by circuit, to be converted to the basic NADIN format upon input to the concentrator, or at the switching center. All messages routed to the international AFTN locations are in conformance with ANNEX 10-message handling requirements, and in accordance with ICAO DOC 8259.

Initially, the two switching centers will be connected via two 9600 b/s leased communication circuits. Each shall have the capability of automatically calling the other switch over a dial-up switched network in case of primary circuit failure. Primary circuits shall be capable of being served by both digital and analog leased data circuits.

Supervisory and intercept operator positions will have terminals including keyboard input, cathode-ray tube and printed output, and access to switches controlling appropriate system functions. A supervisory console will be associated with each switch, to which will be assigned functions of tape and disk mounts and dismounts, monitoring of network performance, making adjustments and corrections should the automatic network actions be unable to cope with overloads,

malfunctions, or other problems. Figure A-7 illustrates a NADIN switch functional block diagram.

2. NADIN I Concentrator Units

Twenty-three concentrator nodes, will be located at each ARTCC (except Balboa) within the FAA jurisdiction, i.e., all twenty ARTCC's within the CONUS and the ARTCC's at Honolulu, Anchorage and San Juan. Redundancy will be used for higher availability and a tape cassette or similar device will be included for fast re-load of the concentrator stored program in case of a malfunction.

The processor in a concentrator performs in accordance with the requirements of the access line over which a message is received. The chief functions are:

- o Addition of information to messages where required (e.g., priority, type, originator/addressee)
- o Checking end of a message, and adding appropriate code
- o Conversion of codes (formats of incoming messages if required)
- o Addition of communication control information after each message frame (e.g., frame accounting, sequential message numbering, message code/format keying, indication of user directed or network management message)
- o Recognizing code/format requirements of calling/called parties and making appropriate conversions

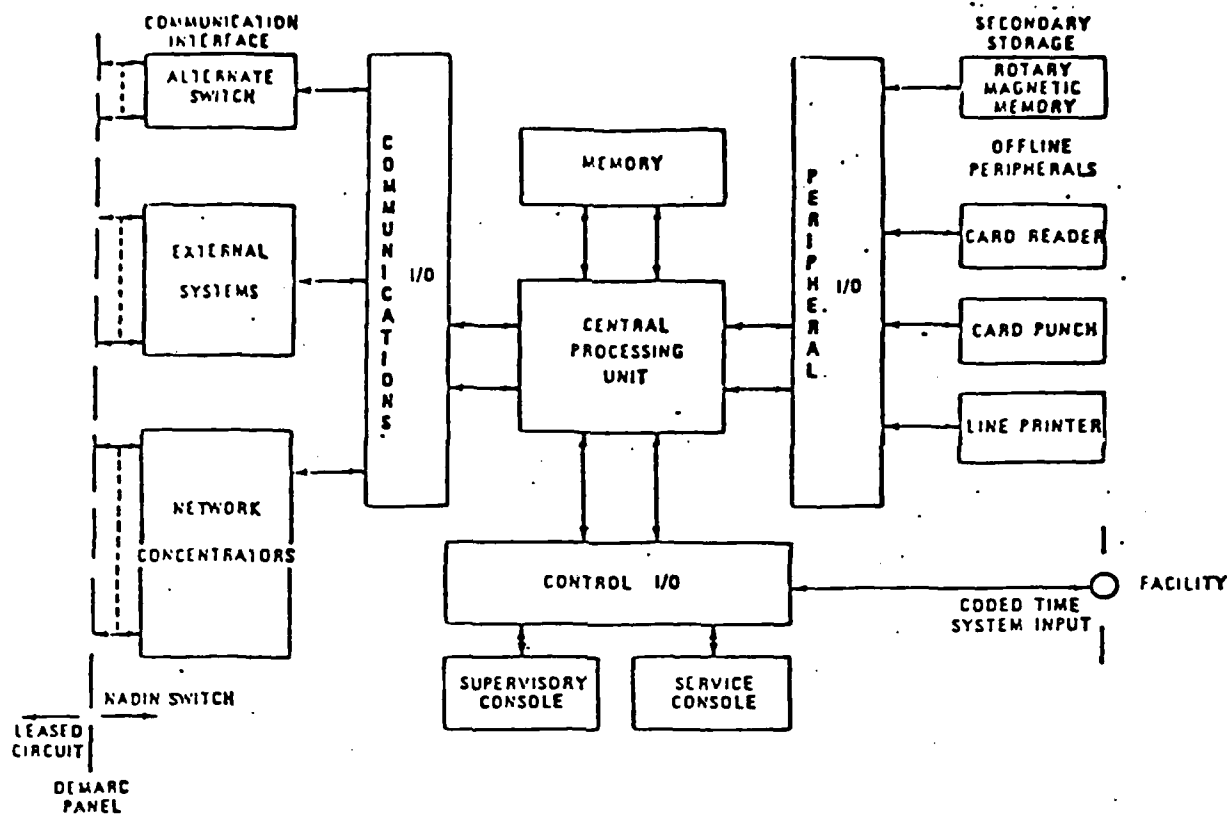

NADIN SWITCH FUNCTIONAL BLOCK DIAGRAM.

FIGURE A-7

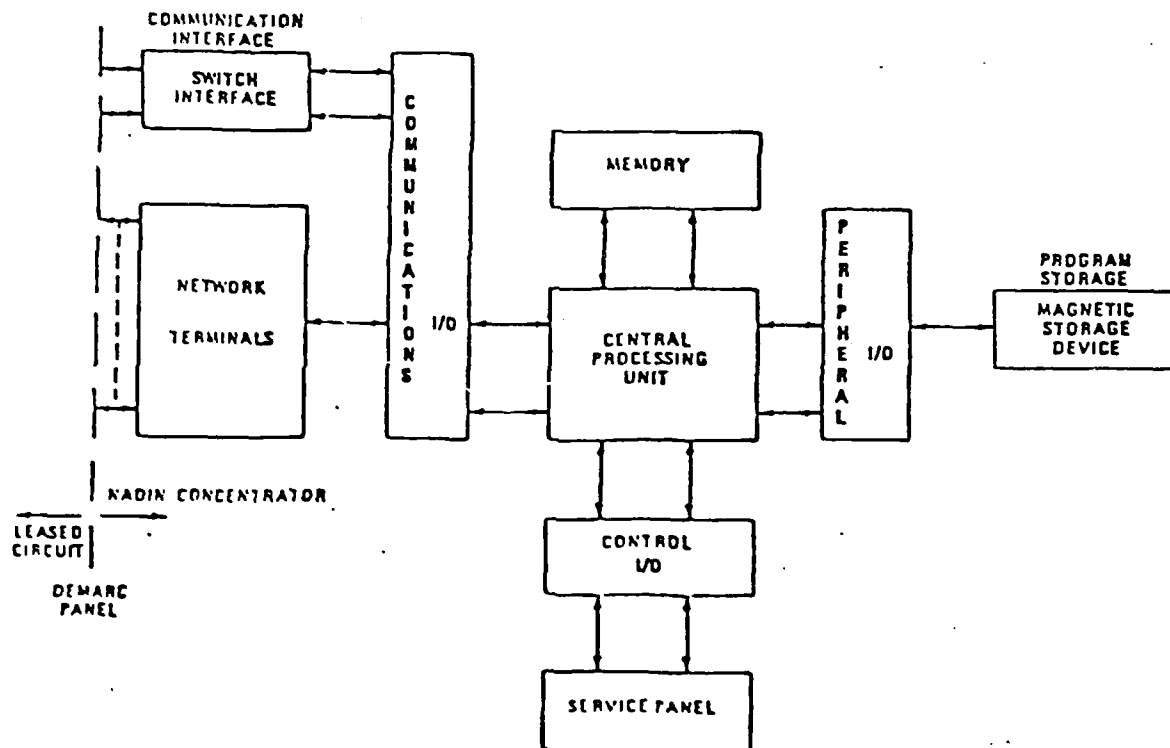

NADIN-I CONCENTRATOR FUNCTIONAL BLOCK DIAGRAM

FIGURE A-8

- o Acting as supply "boiler plate" in frequent fixed format messages, when programmed.

Figure A-8 illustrates a Concentrator functional block diagram.

3. Modems

In NADIN I several types of Modems will be required for terminating various classes of circuits. The following basic types of modems have been specified:

- o Between concentrators and low speed terminals (excluding current-loop type)
 - 0-300 b/s, asynchronous, half and full duplex
 - 0-1800 b/s, asynchronous, half and full duplex
- o Between concentrators and medium speed terminals
 - 2400 b/s, synchronous, half and full duplex
 - 2400 and 4800 b/s, synchronous, half and full duplex.

Variations of the above types may be used to match individual terminals, and will also be employed to interface NADIN switches with external systems.

4. Circuits

Leased dedicated full-time circuits will be used in the NADIN I network, with dialed connections utilized as backup and prime for terminals not requiring full-period service.

- o Links connecting terminals with concentrators will be of the following types:

- Low speed, 50 to 150 b/s asynchronous tele-typewriter communication circuits.
 - Synchronous and asynchronous medium speed circuits.
 - High speed, byte-serial computer circuits, connecting concentrators to the NAS 9020 computer.
- o Concentrators shall connect to the data switches over point-to-point 2400 and 4800 b/s synchronous communication circuits.
 - o Multiple low- or medium-speed communication circuits will be used for connections to international centers of the ICAO network (AFTN).
 - Low-speed, 50 to 150 b/s asynchronous tele-typewriter communication circuits.
 - Synchronous and asynchronous medium-speed circuits.
 - o Two medium-speed 9600 b/s synchronous communication circuits will connect the NADIN switching centers and the Weather Message Switching Center (WMSC) located in Kansas City.
 - o Medium-speed circuits will be used in the automated flow control processor facility co-located with the Jacksonville ARTCC and the Air Traffic Control System Command Center in Washington, D.C.
 - o Low- or medium-speed dial-up capability will be employed to field office terminals located at major FAA activity locations.
 - o Medium-speed asynchronous circuits will be used to automate FSS facilities at the time of NADIN implementation.
 - o Medium-speed synchronous circuits will be used in Air Carrier Communication Systems for automatic exchange of flight data.
 - o Medium-speed synchronous circuits will be used in the National Weather Service processor.

F. Maintenance/Reliability

Very high reliability is a basic requirement of the NADIN I network, with a level of nodal availability of 99.98% which will require employment of additional switching equipment modules for redundancy.

Message flow is closely controlled, and messages are accepted for processing only when facilities are available to handle them and are routed and processed through the system to assure prompt delivery. Network overloads will be prevented by closely monitoring the flow of messages within and between NADIN I and its terminals and connecting systems. Most efficient use of circuits and processing facilities will be assured by analyzing and planning traffic routing in response to system busy hour loading, delay and availability/reliability requirements. Achievement of these goals requires proper management of system software and of storage capabilities of switches and concentrators in the terminals.

Since NADIN I requires very high system availability, the design provides for element or module failure. A sophisticated recovery procedure has been incorporated as follows:

o Internodal Circuit Failures or Degradation:

The defective circuit will be automatically/manually removed by a switching unit, and dial link action will be used to immediately select two temporary replacement circuits. Consequent changes in routing tables and

switching configuration will be implemented while the traffic is resumed. Upon restoration of the defective circuit, it will be placed back in service and the dialed links released.

o Failure of Equipment (including Total Switching System):

Built-in redundancy and short MTTR/restoration time should prevent total failure of a node. However, in case of total failure of a node e.g., a concentrator, its low-speed terminals will not be provided with alternate access to the network. Some high-speed essential terminals will be allowed alternate access to the network through dialed lines. In case of the failure of one of the two switching centers, the second center will have the capability to assume all its functions for the concentrators served by the failed center. This will be done using dialed links with routing tables and operating software automatically amended until the defective switch is restored.

o Message Recovery:

If a message processed by a switch does not arrive at its destination, it will be recognized as a break in the sequence, since sequential lists of transmitted messages will be maintained. A re-transmission will be made corresponding to the missing number, in most cases automatically.

1. Message And Data Recording And Journalling Circuit Related Data

The switching units will maintain a record of periodic count of the number of messages and characters transmitted and received. This allows a number of significant traffic parameters to be calculated for nodes and internodal circuits, which are recorded, analyzed, aggregated, stored, and displayed at an operator console as a measure of loading in segments of the network. Alarms are used to indicate

parameters exceeding prescribed limits. This will include statistics on frame re-transmissions to indicate the quality of transmission elements in the network.

2. Message Related Data

To allow quick re-transmission of lost, broken, and other problem messages, each message is temporarily recorded completely in fast-access storage at the switching centers. Later, it is transferred for long-term retention to a slower-access medium, for administrative referral (if required). Messages which do not require total recording will be sorted out, and their Journal data only will be retained e.g., identity of originator, addressee(s), type, priority, message length, etc.

3. The Cutover Strategy

A very carefully designed, smooth, cut-over strategy will be implemented to avoid unfavorable impacts on network performance and its users. Examples of how such unfavorable impacts will be avoided are:

- o In case of a national AFTN subscriber choosing to remain in the Baudot Code/AFTN format environment, only an update of contact information for operational problems will be required, and general pre-knowledge of the cutover schedule.
- o In other cases, formats and new telecommunication functions available within the NADIN will be accommodated as part of the cutover plan.

- o In cases where software (adaptation of the NAS 9020 and FSS automation) processors will be affected by the cutover process, coordination and mutually acceptable schedules will be created.
- o In more involved cases, where the method of doing business may change services provided by Supplemental B, NAS/BDIS, NAS/WMSC, Center B, and NASNET will be handled within the NADIN, but these circuits will disappear functionally.

G. Milestones and Enhancement Plans

The NADIN program will be implemented very systematically in a number of small, discrete, self-contained stages. In view of the ultimate reliability and availability requirements on this vital system, this appears to be the most logical approach.

The stages of NADIN development and implementation are shown in Figure A-9. Several phases have been defined for the initial stage of implementation as well as for subsequent enhancement as depicted in Table A.2. As seen from the Table, progress is presently being made in Phase II. Computer aided economic/technical analysis on an extensive scale led to the viable and cost effective strategy. The intensive assurance requirements of Phase II caused slight prolongation and delay of specification issuance for procurement and acquisition of hardware and software. This will be followed by installation of the system, cut-over and training of operating personnel. Immediately following will be Phase IV, covering enhancements and associated E&D efforts for updating and revision of system planning of the expansion of the capability of the system.

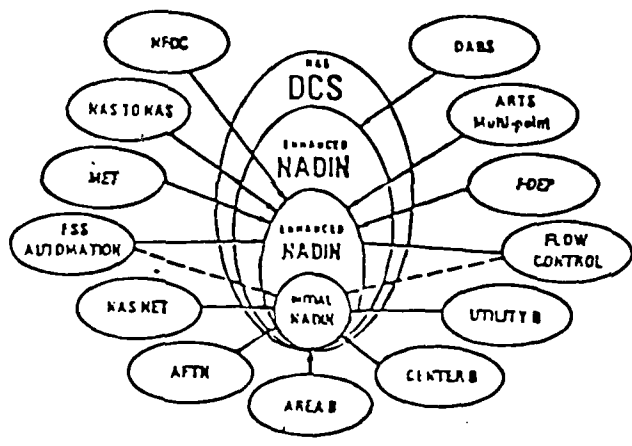

PLANNED EVOLVEMENT OF INITIAL NADIN INTO THE COMMUNICATIONS SUBSYSTEM OF THE NATIONAL AIR-SPACE SYSTEM.

Figure A-9

NADIN DEVELOPMENT SCHEDULE

| | <u>Initiated</u> | <u>Completed</u> |
|--|------------------|------------------|
| <u>Phase I</u> | | |
| Characterization of Existing Networks and Requirements Validation for 1985 | 1974 | 1975 |
| <u>Phase II</u> | | |
| NADIN I Design and Specification | 1975 | 1978 |
| <u>Phase III</u> | | |
| NADIN I Procurement and Development | 1979 | 1981 |
| <u>PHASE IV</u> | | |
| E & D Design for NADIN Enhancements | 1978 | 1981 |

TABLE A.2

These enhancement activities will include short and long term requirement surveys on AAT data transfer as in Table A.3.

As a result of this activity, the scope of the next NADIN upgrade will be evolved. Analytical estimating and implementation strategy will be defined for creating required hardware/software and its utilization in the FAA Communication Network. The NADIN enhancements will include a further integration of weather services (Service A collection and distribution) and total FSIS requirements for data transfer as well as further integration of data communication used in support of the air traffic control mission.

1. Near Term NADIN Enhancement

The FAA has defined eight distinct areas in which NADIN capability will be enhanced to serve:

- o ARTCC/ARTCC (NAS/NAS) digital data communications
- o ARTCC/ARTS (NAS/ARTS) digital data communications
- o Flight Data Entry Processing (FDEP) equipment using replacement devices
- o Future phases of automated FSS digital data communications
- o Future phases of flow control (ATCSCC)
- o Interface with National Flight Data Center
- o Service to upgraded field office Terminals
- o Further integration of weather services to provide integrated MET distribution

FUTURE REQUIREMENT SURVEYS FOR NADIN ENHANCEMENTS

| <u>Type of Activity of Data Communication</u> | <u>Purpose</u> |
|---|--|
| FSIS | Data exchanges between: Flight Service Data Processing Systems (FSDPS), WMSC, and other ATC facilities; |
| Flow Control | ATCSCC exchanges with industry, ARTCCs, Automated Radar Terminal Systems (ARTS), and manual FSS locations; |
| Flight Data Entry and Printout (FDEP) | Communications using replacement medium speed devices on multi-point circuits using standard communication practices; |
| ARTCC/ARTCC Communications | Including the capability for non-NAS data exchanges such as with Canada; |
| ARTCC/ARTS Communications | For ARTS II, ARTS III, ARTS IIIA and EARTS with the capability for multi-point circuitry to terminal locations; |
| NFDC/IS at Oklahoma City | For exchange of airport data base information; |
| Upgrading Field Office Terminal Capability | To provide data base access (NFDC, WMSC, etc.) from Air Traffic Service, Airways Facilities Service, Flight Service Stations; |
| Upgrading Meteorological Communication | For full meteorological messages and digital graphics, data trunking capability to provide distribution of weather data to ARTCCs, Air Traffic Control Towers (ATCTs), and manual FSSs and possible input trunking for data included in the National Weather Service Automation of Field Operation (NSW AFOS) program needed from the NSW and Air Force; |
| Interface with DABS | For Air-ground data link; |
| Survey | Miscellaneous selected DOT requirements. |

Table A.3

- o Other data communications in support of the air traffic control mission e.g., Discrete Address Beacon System (DABS) interactions with ATC facilities, satellite communications with ATC facilities.

As initial NADIN I capabilities include options e.g., higher data transmission speeds and increased processing capability in the switching centers and network, very few newer additions are foreseen for implementing the above services (e.g., addition of limited local traffic switching at concentrators).

2. The Evolutionary Growth of NADIN

The NADIN system has been designed for a systematic growth from its initial deployment to its ultimate goal of a total data communication system in support of the Air Traffic Control mission. Therefore, its design will assure that the following can be accommodated:

- o Node capacity can be increased by adding modules
- o Node functions can be expanded by adding new modules
- o Circuit capacity can be increased by increasing data rate and by adding circuits
- o Users can provide higher capacity terminals
- o Evolutionary changes do not upset ongoing operations
- o Central planning controls changes

The planned program phases for NADIN I are:

| <u>Program Phases</u> | <u>Status/Plans</u> |
|---|---------------------|
| Phase I | |
| Characterization of Existing Networks and Requirements Validation | Completed |
| Phase II | |
| NADIN I Design and Specification | Completed |
| Phase III | |
| NADIN I Procurement and Deployment | |
| RFP | Feb 1979 |
| Contract Award | Sep 1979 |
| Cutover | Nov 1979 |
| Phase IV | |
| E&D Design for NADIN Enhancements | 1981 |
| o FSS Models I & II | (To Start) |
| o Weather Distribution Network | |
| o Automated Flow Control | |
| o DABS Data Link | |
| o Survey of Selected DOT Requirements | |

VOICE SWITCHING AND CONTROL SYSTEM (VSCS)

FAA/ARD-200 is developing and refining the requirements and technology for the development of a new Voice Switching and Control System for the FAA communications system. This effort is being conducted by combining contractor and in-house activities. The Program Manager for the Radio Communications Control System (RCCS), Mr. Leo Gumina, ARD-206, is managing the VSCS program development which will include both the Voice Communication System (VCS) and Radio Communication Control System (RCCS) in a combined system.

The present air-ground communications system (RCS/RCCS) and ground-ground communication system (VCS) employ equipment that have approached or exceeded a normal life cycle (15-20 years). The addition of periodic improvements have added different families of equipment and subsystems resulting in a mixed inventory that requires diverse maintenance skills and is also costly to maintain. The current system is predominantly manually operated and maintained and is a labor intensive system which causes large and increasing recurring costs. The vacuum tube and electromechanical technologies included in the present system have larger space requirements, higher power requirements, lower reliability and response times than are required with current solid state technology [3] .

"To effect the greatest benefit these two independent systems should be replaced by a single system which utilizes modern solid state technology and achieves the following operational capabilities:

- o Increase the speed of establishing communications between controllers and between controllers and aircraft.
- o Increase the system flexibility from the standpoint of rearranging services and adding new services.
- o Reduce the out of service time by automatic line restoral techniques.
- o Reduce the maintenance workload by the use of automatic monitoring and fault isolation techniques.

Technical Approach: To achieve the general operational objectives, studies and minor development tasks have been initiated specifically to answer questions related to the basic technical feasibility and economic acceptablility of a switch replacement program. The studies include: [4]

- o A review, updating and documentation of the operational and maintenance requirements.
- o A survey of currently available switching systems to assess the state-of-the-art of switching and control technology.
- o A study to determine the technological feasibility of combining and/or integrating the interphone and radio subsystems of the ATC communication system.
- o A cost benefit analysis to assess the economic advantages of replacement of the radio subsystem, the interphone subsystem and the combined system.

- o A program to develop and evaluate techniques for in-band signaling to eliminate the need for conditioned Telco lines."

A review and updating of the operational and maintenance requirements has been conducted. Contractor draft requirements documents for the Radio Communications System (RCS), Radio Communications Control System (RCCS), and Voice Communication System (VCS) have analyzed previous studies and current requirements. Controller/specialist position quantities for the en route, terminal, and flight service environments based on previous analyses appeared to be excessive and field data was acquired to establish current requirements. The requirements have been consolidated into the Voice Switching and Control System (VSCS) Requirements. While this is a draft document, it has been updated with current inputs from the regions, been through one working level coordination cycle, is currently in coordination again and is not expected to change appreciably. Requirements for the air-ground and ground-ground voice system used in this appendix are based on the VSCS Requirements document.

A study was conducted to investigate and compare a combined Radio Communications Control System (RCCS) and a Voice Communications System (VCS) with a separate RCCS and VCS. A combined system was defined as a system using the same technology, technique, and module construction throughout. Such a combined system

could encompass various degrees of integration or consolidation of the functional components of the air-ground and ground-ground subsystems [5] .

The generic architecture used in the study is shown in Figure A-10. This generic system included the seven major functional elements: (1) input/output interfaces; (2) call processing; (3) call preprocessing; (4) interconnect network; (5) maintenance interfaces; (6) position elements and (7) trunk circuits. Each generic architectural system had to meet the principal ATC communication interconnect requirements of: Radio, Intercom, Interphone, Support and Automatic Call Distribution (ACD). Additionally, the combined configuration(s) utilized for the comparison with the uncombined system configuration could not be biased by any one of the three candidate switch technologies under consideration, namely, Space Division (SDM), Time Division (TDM), or Frequency Division (FDM). While this latter restriction on the study prevents optimization of the combined configuration architecture, it does not eliminate from consideration any one of the possible approaches. It was felt that these options should be available to proposers for the system development phase.

A review of SDM, TDM, and FDM techniques resulted in the following general conclusions: [4]

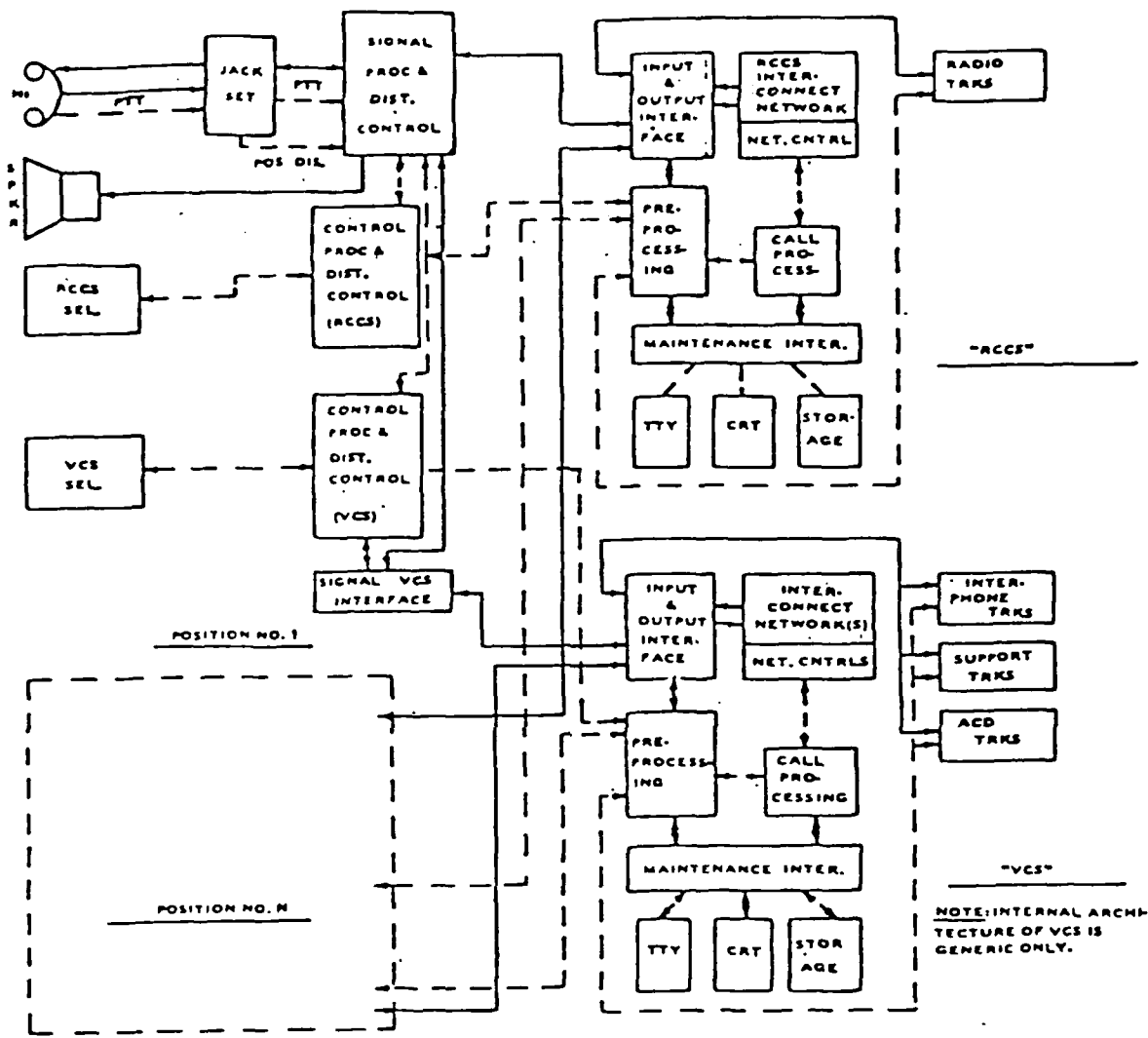

Uncombined RCCS/VCS [4]

FIGURE A-10

- o An interconnect network can be implemented in any one of three basic technologies or a combination of technologies.
- o Optimum network structure or technology is dependent upon the unique requirements of the switching application. Optimum network technology is current state-of-the-art dependent and will vary as component technology advances.
- o Given a specific network structure certain technologies will likely have a distinct economic advantage although the basic switching requirement may be handled equally well by all three basic technologies,

From the initial baseline generic architecture it was readily apparent that the position elements should be combined because of the physical space limitations at a position and the human factors engineering considerations. Likewise, for efficiency, a combined maintenance element would provide for ease in monitoring, surveillance and the maintenance of the VSCS. Trunk elements will probably be combined using a universal interface to accommodate the various types of signaling and control required during implementation. Eventually a single signaling/control scheme between VSCS facilities that is expected to accommodate both air-ground and ground-ground circuits.

The interconnect or switching element was also investigated for consolidation. Because only the RCCS position requires a non-blocking interconnect, a combined switch network would provide an over design for the VCS position and the possibility of undesired connections that would have to be prohibited by the

control function. Further, fewer equivalent crosspoints are required by a system using separate RCCS and VCS interconnect elements. The separate interconnect elements also provide an attractive option for incremental implementation of the radio or ground voice portion separately (Figure A-11). The preliminary system design has further divided the interconnects into radio, interphone, and intercom with all to be the same modular design. The design was sized for a medium TRACON installation and planned for expansion in modular increments to meet larger facility requirements. Small size facilities may be accommodated by use of a single switch network initially with suitable program changes, then expanded modularly as requirements dictate.

"With a modular (expandable/contractable) VSCS architecture, the choice of the common control elements is guided by the same design philosophy as the connecting network. The objectives are to meet the needs for a medium TRACON, and have the flexibility to meet the requirements for the largest en route centers, and also, be downward compatible for smaller installations. (The minimum size installation is to be determined on cost effectiveness.) Both electronic hardware and stored program processors are involved in the common control elements.

The general functions under Common Control are considered

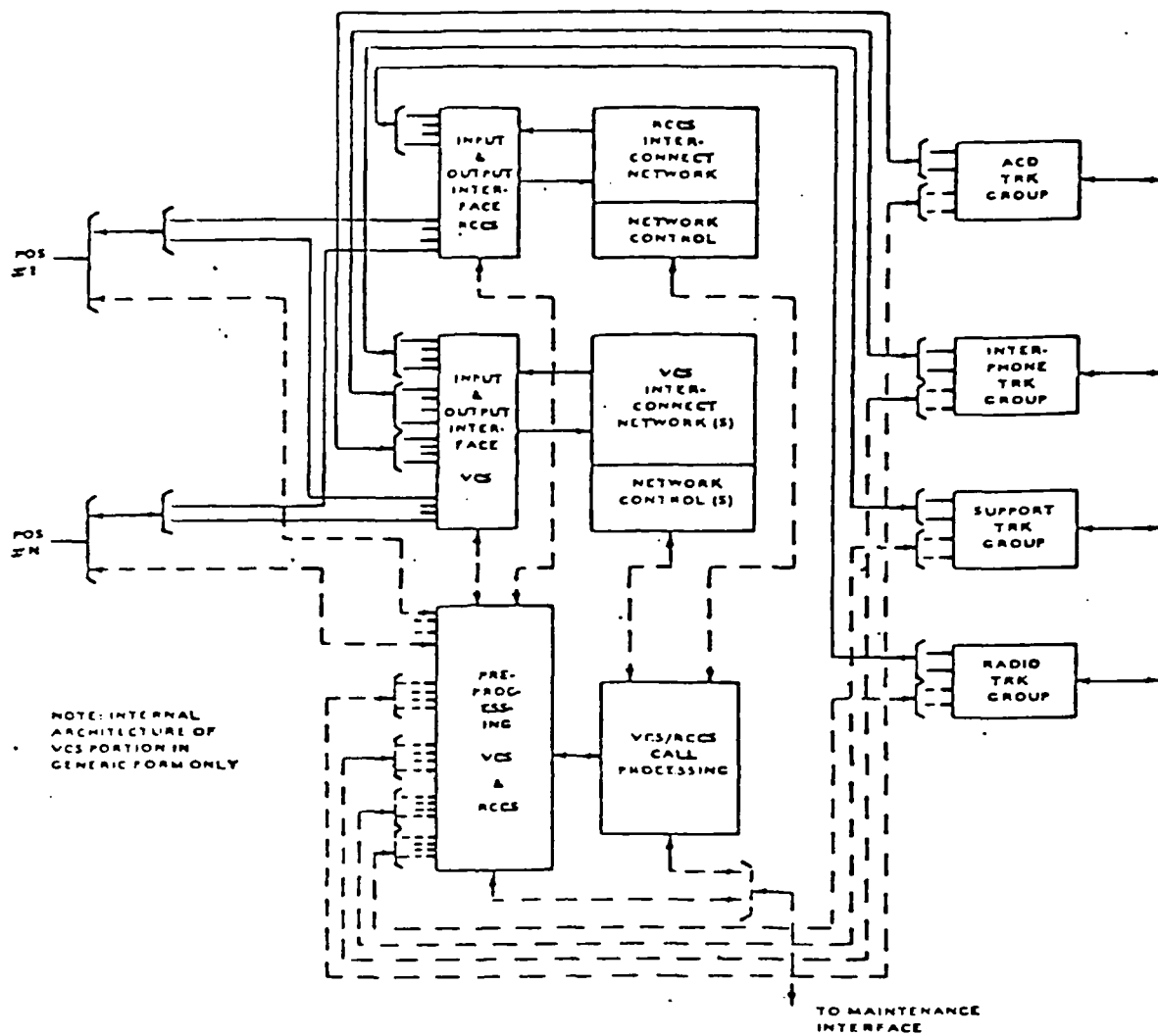

Combined RCCS/VCS (separate Interconnect Network Only) [4]

FIGURE A-11

to be:

- o Line/Trunk Servicing Signaling Processing
- o Call Translation
- o Call Processing
- o Central Monitoring and Data Base
- o System Maintenance

The selection of a centrally distributed microprocessor common control for the VSCS is supported on the basis of:

- o A proven technology approach
- o Very good modularity characteristics
- o Cost effectiveness in terms of redundant elements for reliability
- o No measurable increase in complexity for the largest size systems.

The overall system design strategy for the VSCS involves taking advantage of the low translation and call processing of the Radio Subsystem and incorporation of this function into the same common control used for the IP and IC call processing. This dictates that there be at least a medium amount of communication between the different peripheral processors and a central common control processor." [3] A Central Monitor Processor (CMP) direct interprocessor communication through a bus controller at each CMP (MAIN/STANDBY) was chosen in the preliminary design.

The CMP does the overall switch monitoring and executive

control for the distributed control approach. It also will contain the Data Base associating the dialing or other address data with the lines and trunks. The CMP retains the current state of the system at all times. Calls in the VSCS will be handled in the same general way as position line or trunk call processing with the exception of the radio trunks. Radio trunk paths, because of the relative static nature, will be established by a System Maintenance Monitor Console (SMMC) command entry to the CMP [3] .

The studies are being used to formulate and scope a program for development of the replacement switching an control system. It is projected that program planning will be completed in early 1979. A detailed set of engineering requirements will be developed from an approved and coordinated operational requirement and will be used to solicit development proposals in 1980. As the studies indicate no technological break-through is required to meet the program objectives, a development program containing a limited production quantity is a viable alternative for early system implementation [4] .

The current program schedule plan is: [6]

| | |
|--------------------------------------|---------------|
| System Requirements Statement signed | February 1979 |
| Program Plan completed | March 1979 |
| Acquisition Paper completed | July 1979 |

| | |
|-----------------------------------|----------------|
| Engineering Requirement developed | July 1979 |
| Source Selection Plan developed | August 1979 |
| Procurement Request completed | September 1979 |

Much of the initial work has already been accomplished to meet the above schedule. The RCCS/VCS Combined Study and the Preliminary System Design for the VSCS, while highlighting specific technologies for ease of accomplishment, were deliberately kept general with reference enough so that a functional engineering requirement and procurement request can be based on the initial work without specifying a technology.

It is expected that a development model program will be funded in CY 80. Model testing could then occur at the National Aviation Facilities Experimental Center (NAFEC) in CY 82 with a production contract possible in CY 83. Thus, barring unforeseen program changes, the first production VSCS could enter the inventory as early as 1985. Unless catastrophic, even unforeseen changes should only delay the VSCS into the late 1980s.

APPENDIX A REFERENCES

1. National Airspace Data Interchange Network (NADIN); Kingsley, A. K., FAA Report No. FAA-RD-78-90, (August 1978).
2. National Airspace Data Interchange Network (NADIN) Specifications; DOT/FAA, FAA Document No. FAA-E-2661, (January 1977).
3. Preliminary System Design Report for the Voice Switching and Control System (Draft), Contract NOT FA78WAI-830, October 10, 1978
4. Voice Switching and Control System for FAA Voice Communications, Leo V. Gumina, Systems Research and Development Service Progress Report, August 8-9, 1978, FAA-Rd-78-90, U.S. DOT/FAA, Washington, D.C.
5. Combined Radio Communications Control System (RCCS) and Voice Communications System (VCS) Study, Contract DOT FA78WAI, June 1978.
6. Telecon with Leo Gumina, RCCS Program Manager, ARD-206, November 1, 1978.
7. Preliminary Integrated Communications Concept and Implementation Plan (Draft), Contract DOT FA78WAI-830, October 10, 1978.

APPENDIX B

COLLISION AVOIDANCE SYSTEMS

COLLISION AVOIDANCE SYSTEMS

This section provides an assessment of collision avoidance systems (CAS) envisioned for a collision free National Airspace System (NAS). The section includes a general background and a historical development of the systems proposed by various organizations as part of the efforts directed towards arriving at a national standard for CAS to be issued by the Federal Aviation Administration (FAA).

It is noted that although the urgency of introducing a standard is being felt by all concerned in the scenario of mid-air and near-miss situations, it is nevertheless considered advantageous to delay standardizing an imperfect system than to bear the economic and safety related consequences of a hasty choice.

I. GENERAL BACKGROUND

With the increase in air traffic density, situations where two aircraft are dangerously in close proximity are increasing. These situations have resulted in serious near-miss encounters and mid-air collisions.

To insure the air travel safety, the FAA has encouraged design, development and testing a number of sophisticated electronic systems. Upon successful conclusion of tests on the

proposed systems, national standards will be developed under the Aircraft Separation Assurance Program (ASA). In addition to the FAA other agencies are concerned with flight safety and are contributing in related fields, e.g., the NASA Safety Reporting System.

A. Description Of The Problem

The NAS is being used by both civilian and military aircraft, the former being operated either by airlines or by general aviation. The navigable airspace available for these users can be divided into:

- o Positive controlled airspace (PCA)
- o Uncontrolled airspace
- o Terminal airspace

The planned distribution of the airspace is shown in Figures B-1A and B-1B [22] . Collision avoidance is concerned with aircraft separation throughout the airspace for conflict-free terminal sequencing and spacing control.

The statistics [1] over a 12 year period (1967 - 1976) reveal the following:

- o Mid-air collisions - 20-40 per year
- o Fatalities - 60-70 per year
- o Collisions per million flight hours in 1965 - 1.2; in 1976 = 0.6.

Some recent mid-air collision and near mid-air collision

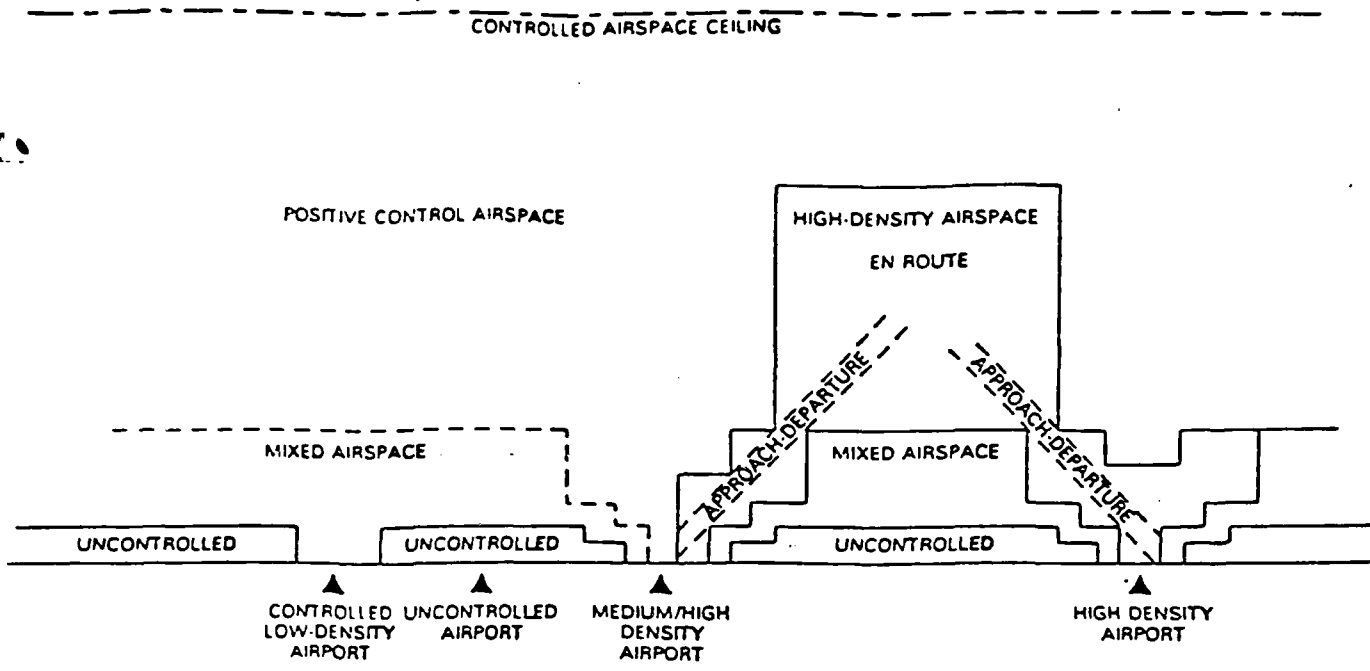

En route and Terminal Airspace Structure-Elevation View (1995)

Figure B-1A

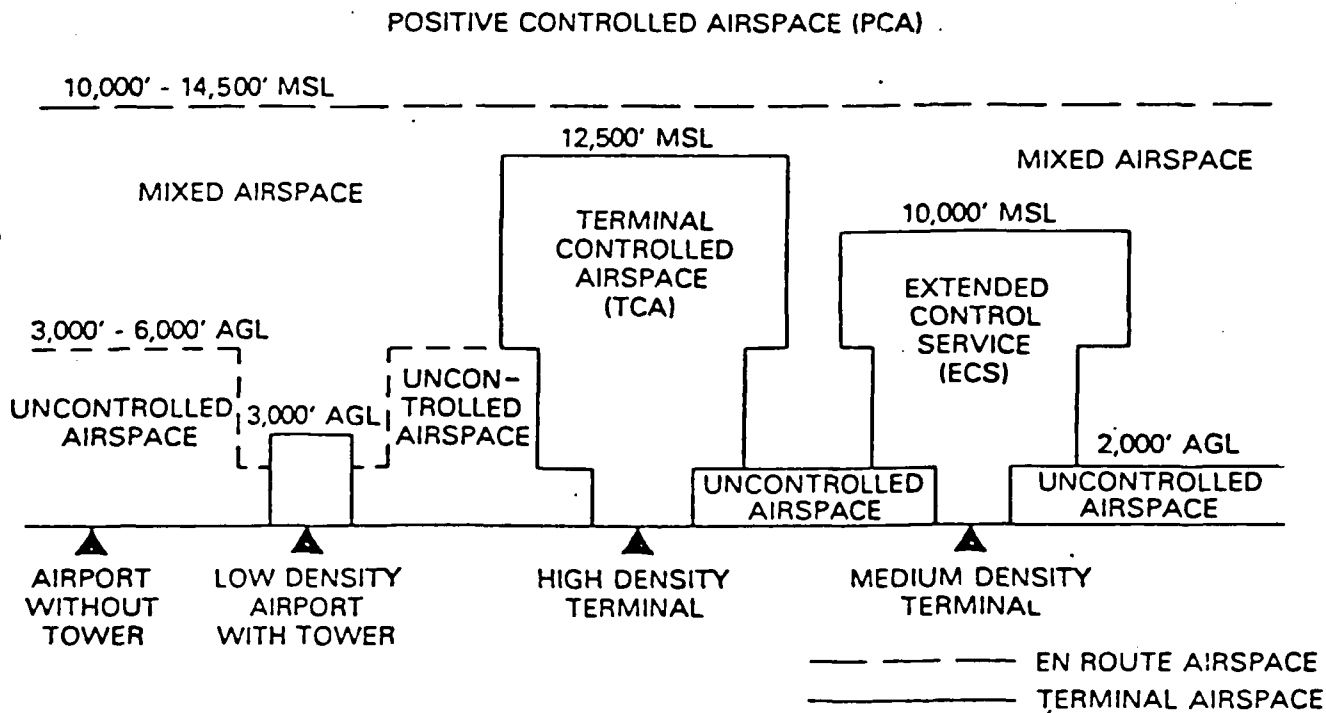

1982 Baseline System Airspace Structure

Figure B-1B

statistics have been analyzed and shown in Figures B-2A and B-2B, which reveal that:

- o Half of all collisions occur within 5 miles of an airport and below 3,000 feet.
- o Half take place in en route and terminal air space.

These collision and near-miss encounters are largely attributable to the aircraft flying under visual flight rules (VFR), and very little to those flying under the instrument flight rules (IFR).

Analysis of near-miss incidents in 1975 (by NASA) reveals that no type of airspace or ATC control position is immune to the occurrence of potential conflicts.

Two aircraft may accidentally get into a potentially threatening situation due to:

- o The inability of the VFR (uncontrolled) aircraft using see-and-avoid techniques to maintain safe separation from IFR aircraft in controlled and transition areas.
- o The inability of the VFR aircraft using see-and-avoid techniques to maintain safe separation from other VFR aircraft in controlled and uncontrolled airspace.
- o Aircraft deviations due to pilot error or equipment malfunction.
- o ATC system errors.
- o ATC system hardware/software failures.

As defined for a CAS algorithm, two aircraft are considered

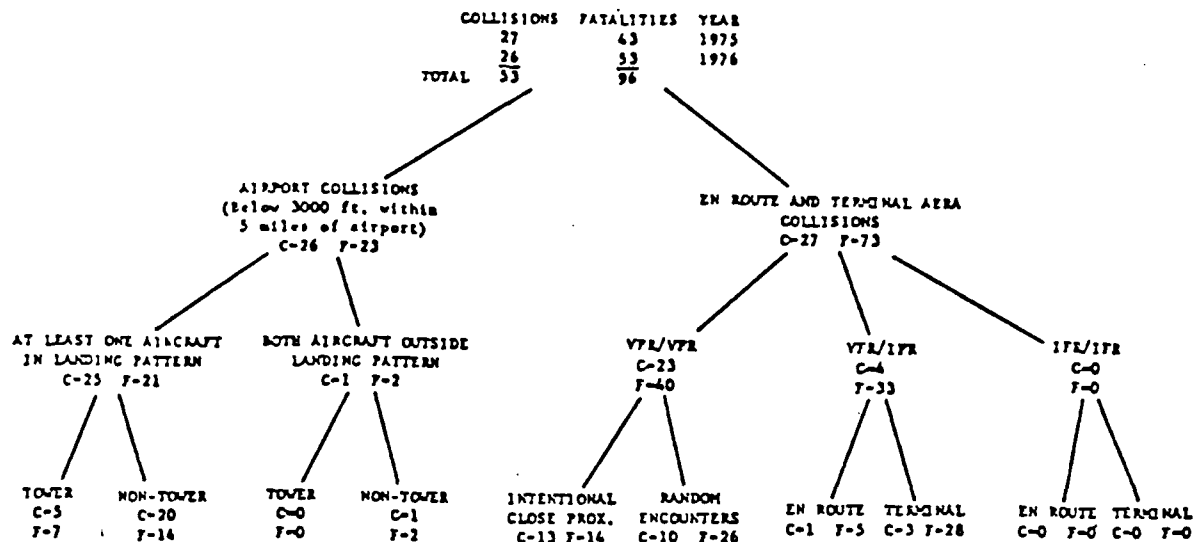

MID-AIR COLLISIONS THAT OCCURRED WITHIN THE CONTERMINOUS U.S. 1975-19

Figure B-2A

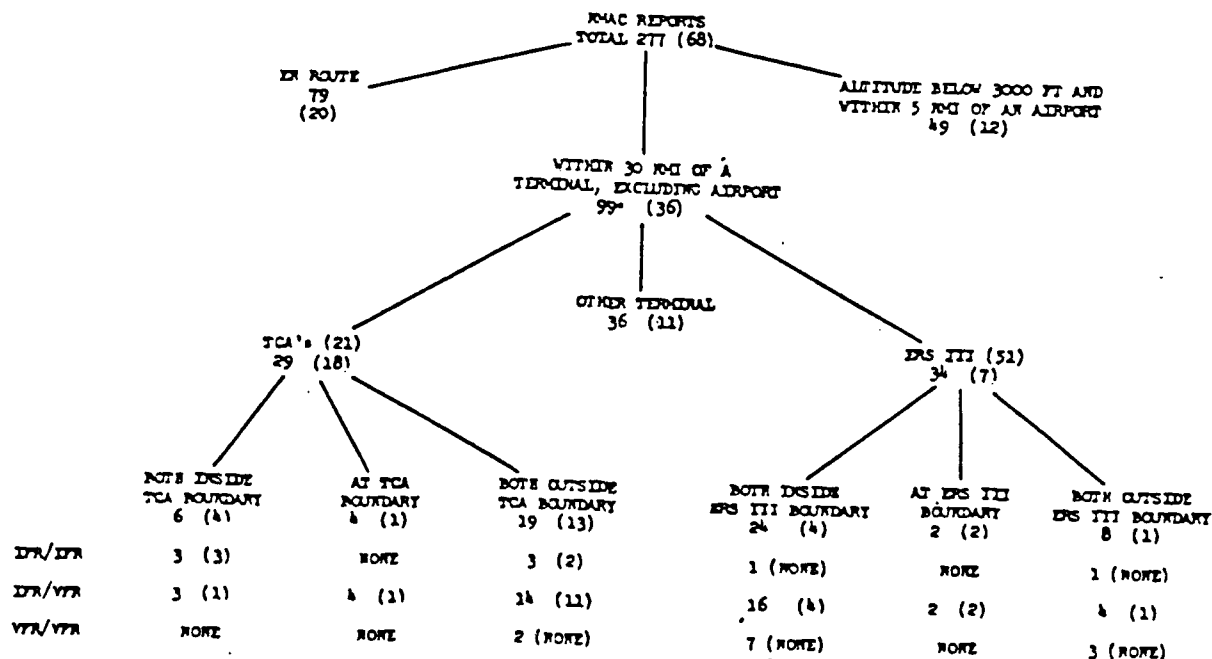

() AIR CARRIER INVOLVED

1975 FLIGHT STANDARDS NEAR MID-AIR COLLISION (NMAC) REPORTS

Figure B-2B

to be in potential conflict when the following parameters are satisfied:

- o The estimated time to closest approach is less than 45 seconds, and
- o The estimated horizontal miss distance is less than 1 n.mi or the estimated vertical separation at closest approach is less than 1,000 feet.

A number of measures have been taken by the FAA to assure collision avoidance between airborne aircraft. These measures include; definition of flight rules, requirements for instrumentation in potential areas of conflict, definition and development of systems to enhance pilots "see-and-avoid" capability and air traffic controllers decision making capability to reduce human error. VFR aircraft are equipped with an encoder and a transponder for flight above 12,500 feet; when equipped with a transponder and a two-way radio, VFR aircraft are allowed to use the terminal control area and positive controlled airspace. Systems are being developed which will provide pilots with information to assist them in resolving potential flight path conflicts with other aircraft, should they develop, i.e., (1) the traffic advisory, and (2) the resolution advisory. The objectives of the traffic advisory service are to assist the pilot in:

- o Obtaining visual acquisition of aircraft that are or will be close enough to be of concern.
- o Evaluating whether or not an aircraft represents a threat.

- o Selecting a safe and effective escape maneuver.
- o Maintaining separation in the absence of visual acquisition.

A number of government agencies, commercial and non-profit organizations have made major efforts in the past decade to cooperate in implementing a program of safe flight through collision avoidance systems.

A number of concepts have evolved concentrating on electronic computer based devices for proximity warning, conflict indication, and guidance during evasive maneuvers. Some of these concepts have advanced into design and development stages and are being subjected to flight-testing and computer simulations. Most of them have been found to have inherent weaknesses and further work is continuing.

B. Historical Perspective

The preliminary conceptual work on a system to prevent mid-air collisions can be traced back to 1945. The earlier development phase until the late 1950's was based on the possibility of accommodating a radar on board the aircraft which could detect the presence of other aircraft in close proximity.

By the early 1960's it was felt that the radar-on-board concept, while very attractive and feasible, was uneconomical.

The work in this field then concentrated on cooperative systems in which an aircraft would detect another aircraft only through intercommunication of necessary data when both aircraft were equipped with mutually compatible devices.

The development of cooperative collision avoidance concepts advanced by the mid-sixties to a stage where the Air Transport Association (ATA) formed a special committee ANTC-117. [2] This committee was asked to write and publish a CAS specification aimed at ensuring the safe separation of aircraft in flight independent of ground control, although ground stations could provide time synchronization for participating aircraft. In order to achieve this goal, several algorithms were proposed for the generation of warnings and alarms, triggered by measured values of separation distance, separation rate, and altitude difference between two aircraft, as well as the rate of altitude change of aircraft. These alarms in turn, were to trigger various cautions and commands to pilots, thereby queueing them to perform certain avoidance or escape maneuvers: viz: stop turning (also known as "rollout"), limit vertical speeds, or change altitude. Bearing information is not normally available, therefore escape maneuvers would be calculated so as to take place in the vertical plane only.

The committee wrote and published a specification in 1967. This specification which has undergone several modifications is

based on radio frequency measurement of range and range rate as well as exchange of data on altitude. The technique was called the time-frequency (T/F) concept. The specification called for the use of highly stable synchronized oscillators allowing one-way range and range measurements. In addition, mutual interference was reduced by using synchronized time-multiplex.

This ANTC-117 committee specification and subsequent revisions became the guideline for the avionics industry, which continued its search for a practical Collision Avoidance System (CAS). Several concepts besides the T/F concept were developed, the most significant being the interrogator-transponder technique which is also known as the beacon technique. Use of the Air Traffic Control Radar Beacon System (ATCRBS) was made in one system utilizing a Time-of-Arrival (TOA) technique, which performed in a passive mode without causing interference to ATCRBS.

A number of commercial organizations entered the research, i.e., Bendix Corporation, RCA, Honeywell, McDonnell Douglas Electronics, Litchford Electronics and Sierra Research. Many of these corporations terminated their efforts in the early stages, however, three of them were awarded funds by FAA/ARPA to develop and present their prototypes for thorough testing. All the systems conceived, designed or developed, have their basic merits. However, their inherent weaknesses as discovered through thorough



testing, made them unsuitable for adaptation as national standards.

After thorough examination of currently developed concepts, the FAA decided to devise its own concept of the BCAS system and the ATARS. Work on this concept is progressing at Lincoln Labs (of MIT), MITRE/MITREK Corporation and NAFEC in addition to the FAA's own R&D and Systems Engineering departments.

C. Increases in General Aviation

From the recently issued FAA Aviation Forecasts, Fiscal Years 1979-1990, September 1978, it can be seen that (Figure B-3) general aviation aircraft numbers will grow to become 92.5% of total fleet size by 1985, 77.4% of the annual operations, while representing 82.2% of the peak instantaneous airborne count (PIAC). All the three categories include substantially larger proportions of general aviation aircraft than the present. The corresponding proportions of air carriers and military aircraft are each anticipated to be approximately halved until 1985 (see Figures B-4, B-5A and B-5B). These observations have special significance because general aviation aircraft are usually lower priced units on which high priced sophisticated devices are not imposed. Notably, an air carrier cooperative electronic system can only detect the presence of an aircraft which carries an onboard transponder. Thus, transponders have to be designed to be highly reliable and affordable to general aviation aircraft operators.

LEGEND

| | |
|---|------------------|
|  | GENERAL AVIATION |
|  | MILITARY |
|  | AIR CARRIER |

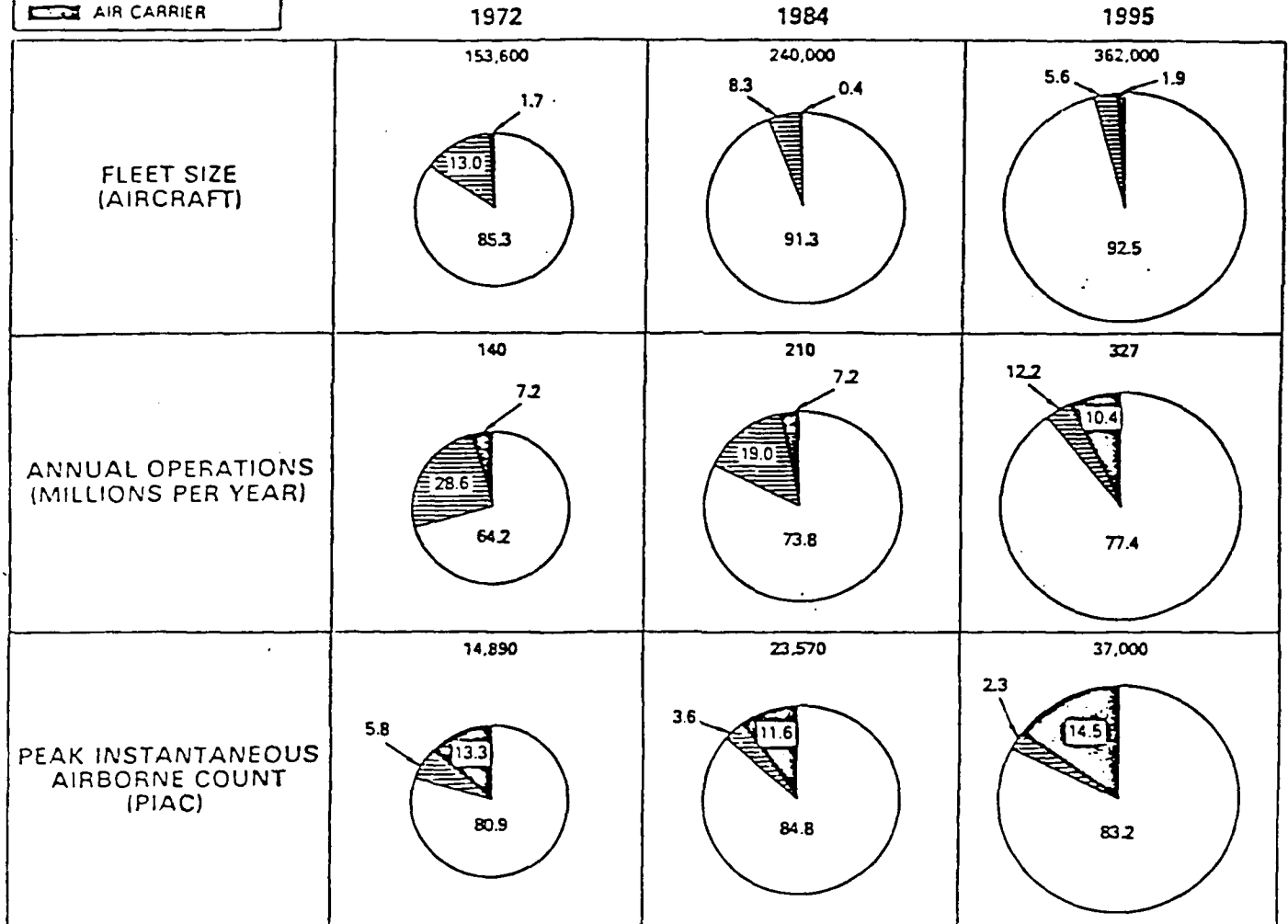
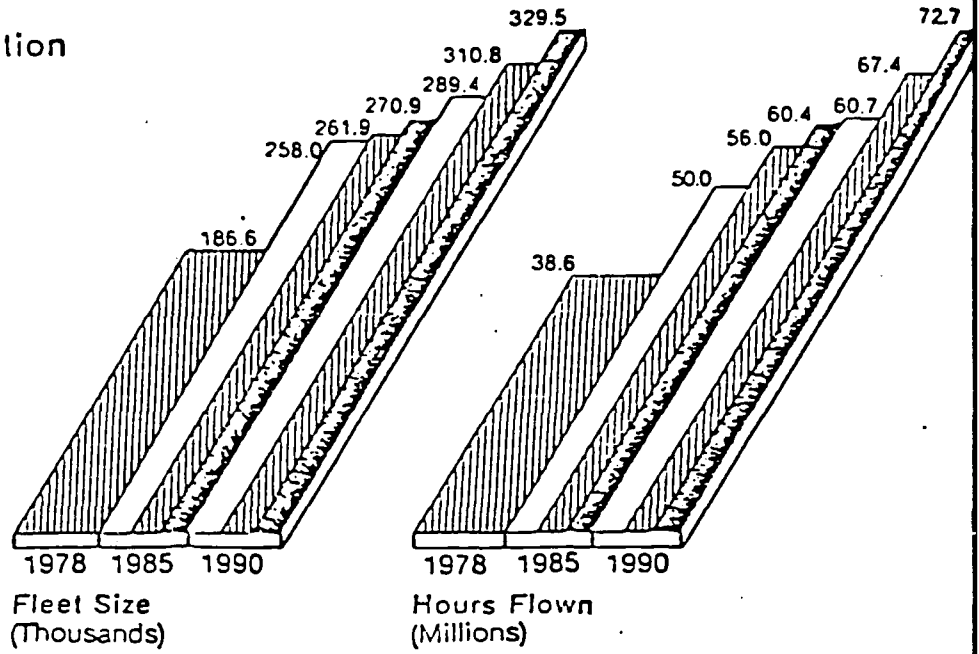

Figure B-3 Projected Air Traffic Parameters Source: Advanced Air Traffic Management System Study Overview. June 1975

General Aviation



Air Carriers

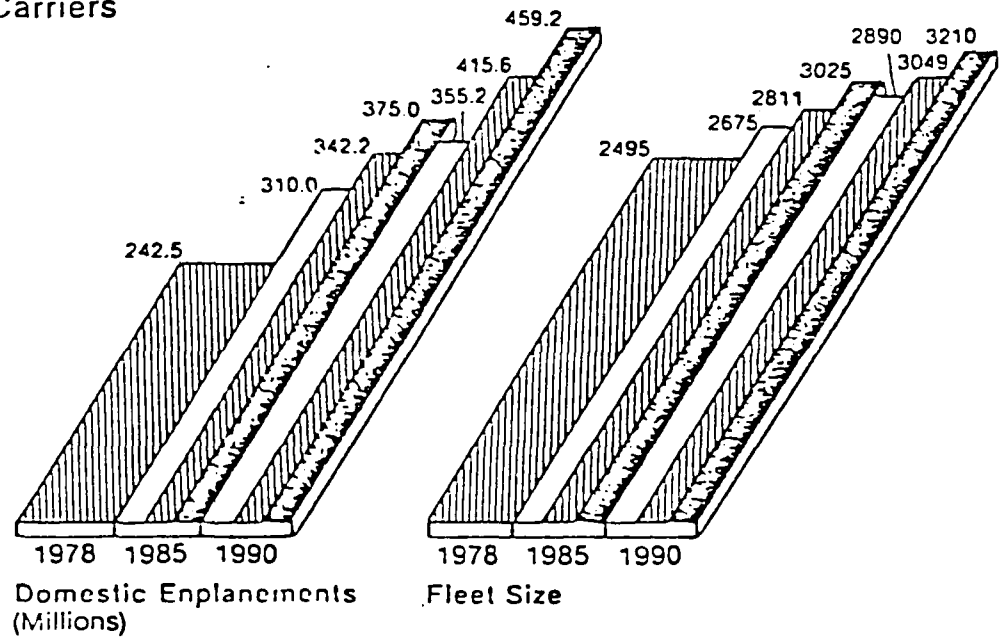

Figure B-4 A Comparison of Aviation Forecasts
 Source: FAA Forecast. September 1978.

FiB-5A

**Instrument Operations
At Airports With FAA
Traffic Control Service,
Fiscal Years 1973—1990**

| | FY 1978 Status (Growth) | Forecast (Total Growth) |
|------------------|----------------------------|----------------------------|
| Air Carrier | + 5.0% | + 26.7% |
| Air Taxi | +11.5% | +127.6% |
| General Aviation | + 3.3% | + 81.5% |
| Military | 0.0% | 0.0% |
| Total | + 3.8% | + 59.0% |

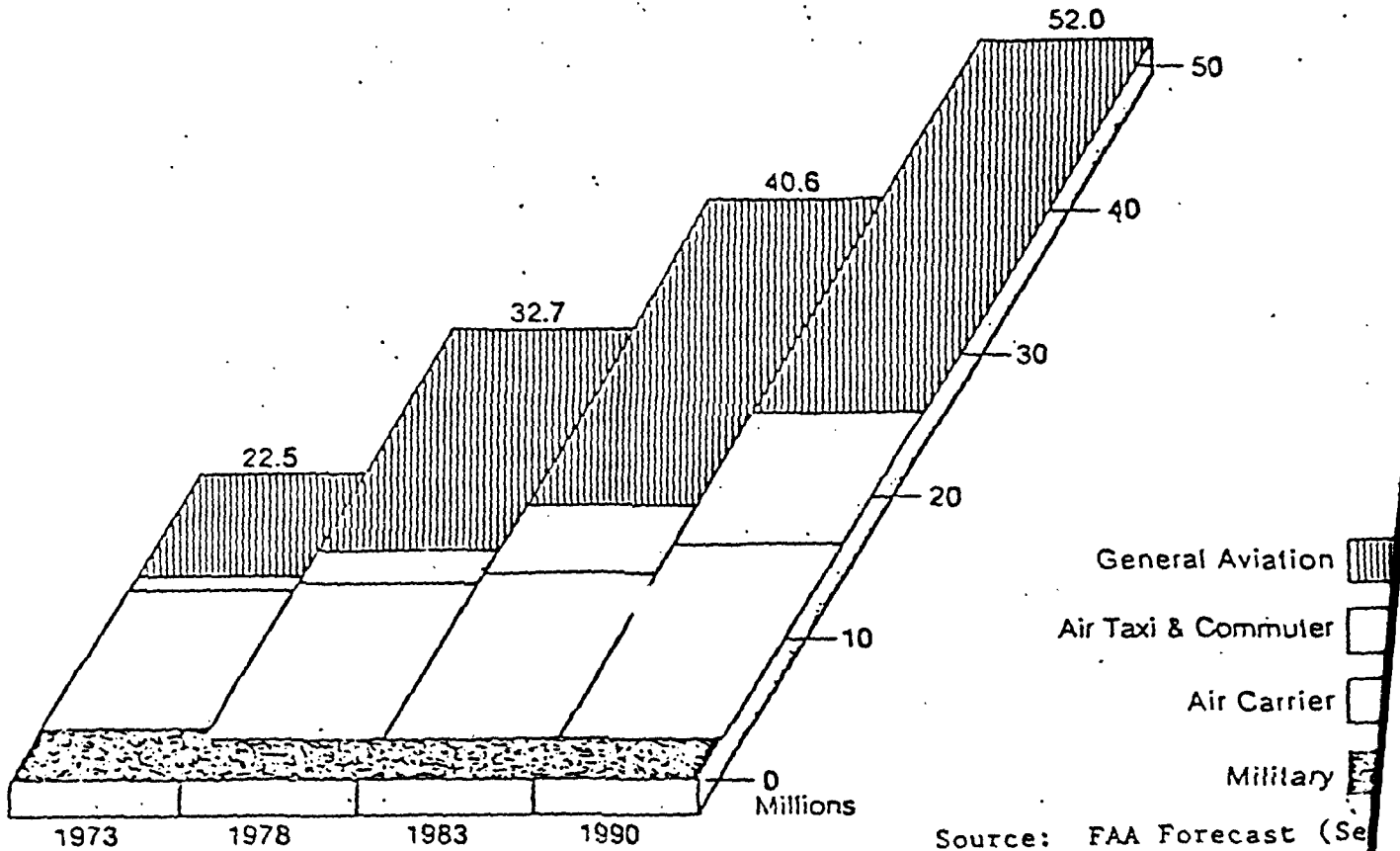
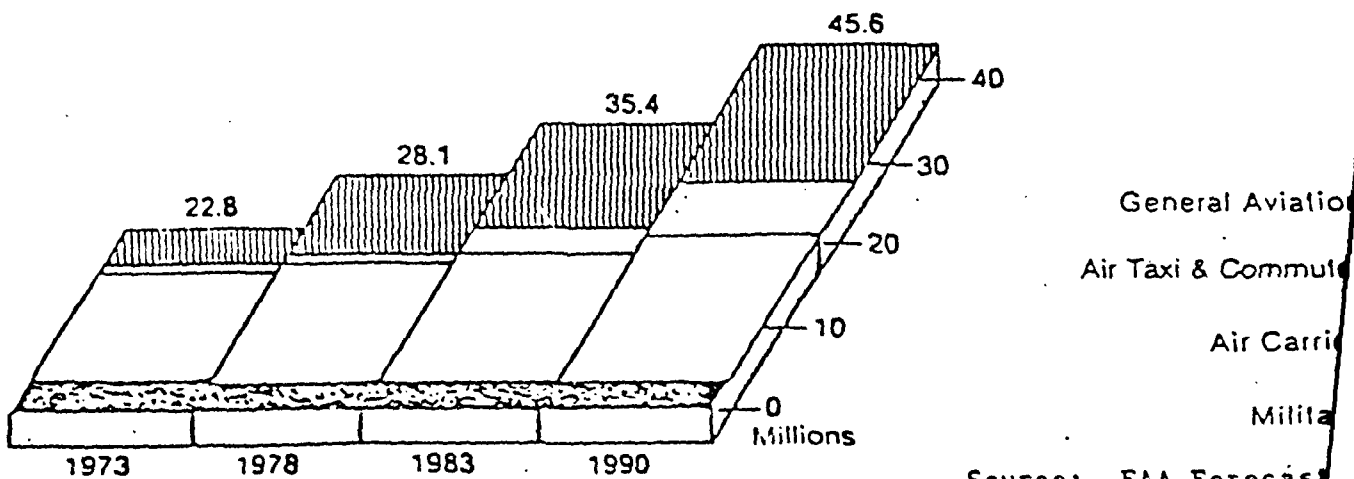

Figure B-5B

**IFR Aircraft Handled by
FAA Air Route Traffic
Control Centers, Fiscal
Years 1973—1990**

| | FY 1978 Status (Growth) | FY 1978—90 (Total Growth) |
|------------------|----------------------------|------------------------------|
| General Aviation | +18.8% | +119.5% |
| Air Taxi | +18.8% | +205.1% |
| Air Carrier | + 4.6% | + 27.1% |
| Military | 0.0% | + 0.0% |
| Total | +8.1% | + 62.7% |



Another important factor which influences the development and choice of the collision protection devices is the acute need for such devices in Terminal Airspace where the density of air traffic is increasing and traffic separation is critically important. Most electronic sensing devices become "confused" by the preponderance of replies coming from a large number of aircraft in close proximity. The challenge of the future is to arrive at universally applicable interconnected ground and aircraft based systems which will assure totally safe and collision-free airspace for very high density air traffic areas.

D. Human Factors

Human factors have been given a high priority in the design of all aircraft separation assurance programs. The success of any such program depends heavily on how easily a pilot or air traffic controller understands the output of the system and how this leads to the accurate performance of an appropriate action or maneuver. In particular, the generation of evasive maneuvers by a computer and their acceptance by pilots has been a subject of study. In other words, mathematically generated evasive maneuvers have in some cases been found to be different than established preferred human (pilot) reactions to a similar situation.

Many basic questions have been explored [1] such as:

- o What basic information must be provided to the pilot to accomplish the stated objectives?

- o What precision is required in the information provided?
- o What combinations of data and display techniques should be considered?
- o What criteria should be used for displaying a traffic advisory?
- o How should the urgency of the situation be conveyed to the pilot?

Some important points studied in this connection are:

- o Design of: cockpit display information without requiring further evaluation or computation by crew; display of easily interpreted visual commands; aural or other commands to keep pilot reaction time lowest.
- o Allowance of appropriate time to allow for pilot reaction to given commands.
- o Study of pilot reactions and preferences by mathematical modelling and simulations as well as test flights. Examples of items studied are pilot's assessment of the effectiveness of:
 - Horizontal escape maneuvers as opposed to vertical escape maneuvers.
 - Intruder Positional Data (IPD), with commands as opposed to a command only mode.
 - Desensitized logic (i.e., reduced warning times).

Development of algorithm concepts including solution of some specific pertinent problems, e.g.:

- o Handling of multiple advisories,
- o Concepts for providing advisory data via a data-link,
- o The traffic advisory service and its impact on the ATC system of procedures,

- o The traffic advisory service and its compatibility with and ability to complement the resolution service
- o Warning time required by a pilot in the traffic pattern to successfully use a computer voice message in finding and evading other traffic - does threat detection modify the pilots visual scanning?
- o Should both aircraft receive call outs or only one (the "interceptor" or the "evader")?
- o Is a recommended avoidance maneuver desirable in the verbal message? Is it achievable?
- o Are more "strategic" warnings needed as opposed to warnings when the traffic is already in conflict?
- o Will the rate of false alarms (warnings that pilots feel are superfluous) be low enough to permit successful use during high traffic levels?

Application of useful results obtained in system design enhancement efforts. In the case of a BCAS System test it was concluded that:

- o Pilots strongly desire intruders' positional data (IPD) information in the single intruder environment.
- o While no universal pilot preference based on effectiveness for one escape dimension over the other exists, pilots have a preference for the vertical escape maneuver.
- o Pilots are unable to distinguish between high and low command threshold levels.

II. AIRCRAFT SEPARATION ASSURANCE PROGRAM

The FAA has initiated an Aircraft Separation Assurance (ASA) Program to reduce the probability of mid-air collisions and near-miss encounters in all regions of airspace and between all classes

of users. The three primary programs which have been pursued by the FAA are described in the following paragraphs.

A. Terminal Conflict Alert Function Of Air Traffic Control

The Terminal Conflict Alert Function is a feature designed to detect potentially hazardous aircraft pair encounters and to provide an aural/visual alert to a controller with sufficient time allowed to issue control instructions to the pilots involved.

The ARTS-III terminal control system introduced in 1973, in the nations busiest operational airports, provides an automated capability to collect information e.g., aircraft ID, altitude and ground speed, by tracking beacon reporting. In 1975, it became possible to add the Conflict Alert (CA) function, which has lately been implemented in all airports equipped with ARTS-III.

B. Conflict Avoidance Systems

These two collision avoidance systems are primarily designed to aid the pilot in maintaining safe separation. Development of the two systems is proceeding independently; however, there is a coordinated effort where commonality of equipment exists (in particular; airborne transponders, cockpit displays and, to a certain extent, resolution logic).

1. Automatic Traffic Advisory And Resolution Service (ATARS)

ATARS will serve as a separation assurance backup to the ATC system in the airspace served by DABS. For uncontrolled aircraft, the ATARS traffic advisory service will enhance the pilots see-and-avoid capabilities while the resolution service will provide separation services not previously afforded by the ATC system.

2. Beacon-Based Collision Avoidance System (BCAS)

Initially, FAA programs included an Airborne Collision Avoidance System (ACAS). Three ACAS systems were tested by or under FAA auspices. All were cooperative; that is, users who bought such a system would get no protection against aircraft that had not installed similar equipment. This implied mandatory equipage and placed a heavy economic burden on general aviation. Because of this and other problems (international aspects, lack of bearing data, radar altimeter interference, etc.), these systems were rejected and it was decided to proceed with a Beacon Collision Avoidance System (BCAS) which alleviates many of these problems.

BCAS is a concept for an airborne collision avoidance system based on the use of replies transmitted by the Air Traffic Control Radar Beacon System (ATCRBS) transponders or the future Discrete Address Beacon System (DABS) transponders.

There are two basic modes of operation; Active Mode, for use in areas where no ground radar coverage exists and low to medium density environments and; Passive Mode, for use in high density areas with ground radar coverage.

BCAS provides supplemental collision protection within ATC system coverage, and primary collision protection outside ATC coverage and capitalizes on present and future avionics investments (domestic and international).

BCAS via its active mode, will be able to provide back-up separation services to equipped aircraft outside of DABS coverage where ATARS cannot be provided.

III. NEAR-TERM AUTOMATION PROGRAMS

Near-term automation programs are aimed primarily at making it easier for the controller to handle individual aircraft, [3] and hence will improve the aircraft separation function. Touch entry/display devices in both the terminal and en route environment are provided for making controller data handling and display easier. There are still a number of important questions regarding the specifics of the controller-computer interface for these near-term productivity and safety improvements.

The thrust of the near-term work has been to make the controller more efficient. Having a computer that "senses" the

traffic situation and can "react" intelligently opens up a multitude of new approaches to air traffic control. The area of avionics and the pilot role is being stressed. More aircraft will have to be equipped with ATCRBS transponders, and later may require DABS transponders. With certain system alternatives, computers on-board the aircraft and possible on-board interrogation equipment will be needed.

In some portions of the airspace, there will be a possible shift in the aircraft separation responsibility from the ground to the pilot. The following are projects covering the broad range of applications and approaches to automation.

A. The Automated Terminal Service (ATS)

The ATS system is for the VFR tower application, and represents a very low level of machine intelligence. The initial version of ATS does not involve automatic generation of ATC clearances. A mobile testbed designed for feasibility testing is operational at the National Aviation Facility Experimental Center (NAFEC). It will be moved to Miller Air Park at Tom's River, New Jersey for an extensive feasibility evaluation, where many users will participate. An artist's concept of the automated ATS is shown in Figure B-6.

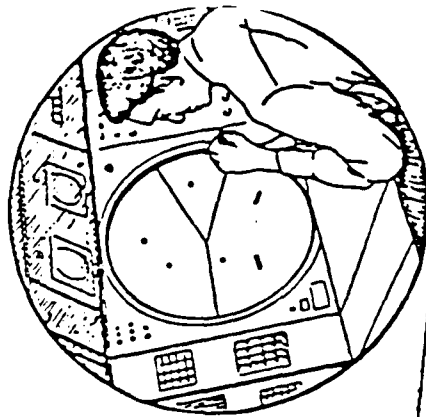

Air traffic controller at remote ATC facility handles controlled traffic for the airport (may have digital remoting of ATS surveillance data and an RCO)

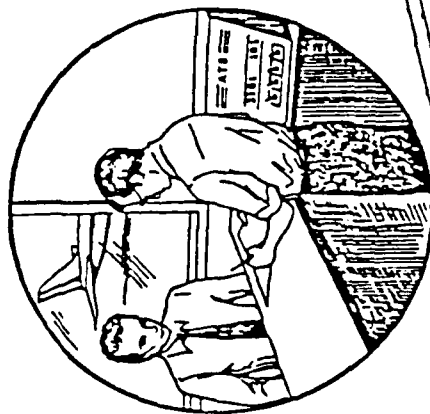

Fixed base operator at airport manager displays active runway, etc., using system control console when necessary

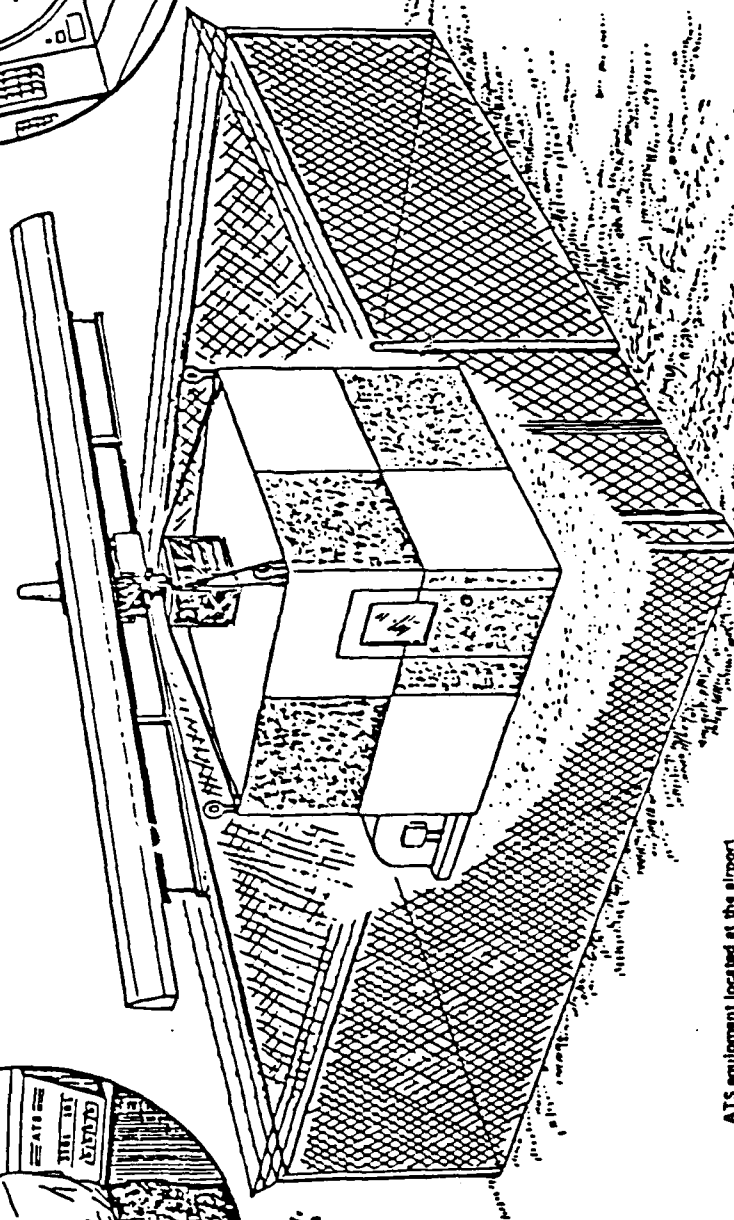

ATS equipment located at the airport (might be installed in an existing building if space is available)

ARTIST'S CONCEPTION OF AN AUTOMATED TERMINAL SERVICES SITE [4]

Figure B-6

1. ATS General Description

The ATS is based on a computer "awareness" of the traffic situation in the airport region. The system projects aircraft flight paths and generates traffic advisories and threat messages. A voice response system on the ground broadcasts the messages. The computer provides information to the pilot, but the responsibility for aircraft separation rests with the pilot. Since ATS is meant for VFR tower applications, it offers a reasonable assignment of responsibilities.

Based on accident analyses and studies of pattern behavior at candidate airports, a full awareness of the traffic around the airport (see Figure B-7) supported by a threat detection service can assure the safety for the VFR tower environment. The feasibility test program will demonstrate that an automated system is an acceptable application to the VFR tower.

There are a number of questions relating to the effectiveness of threat detection. Threat detection represents one of the cornerstones of the ATS concept. What will be the effect of non-beacon-equipped aircraft in the ATS environment? Presently, the percentage of non-equipped aircraft is high at VFR-towered airports. While FAA projections indicate that this percentage will decrease, it

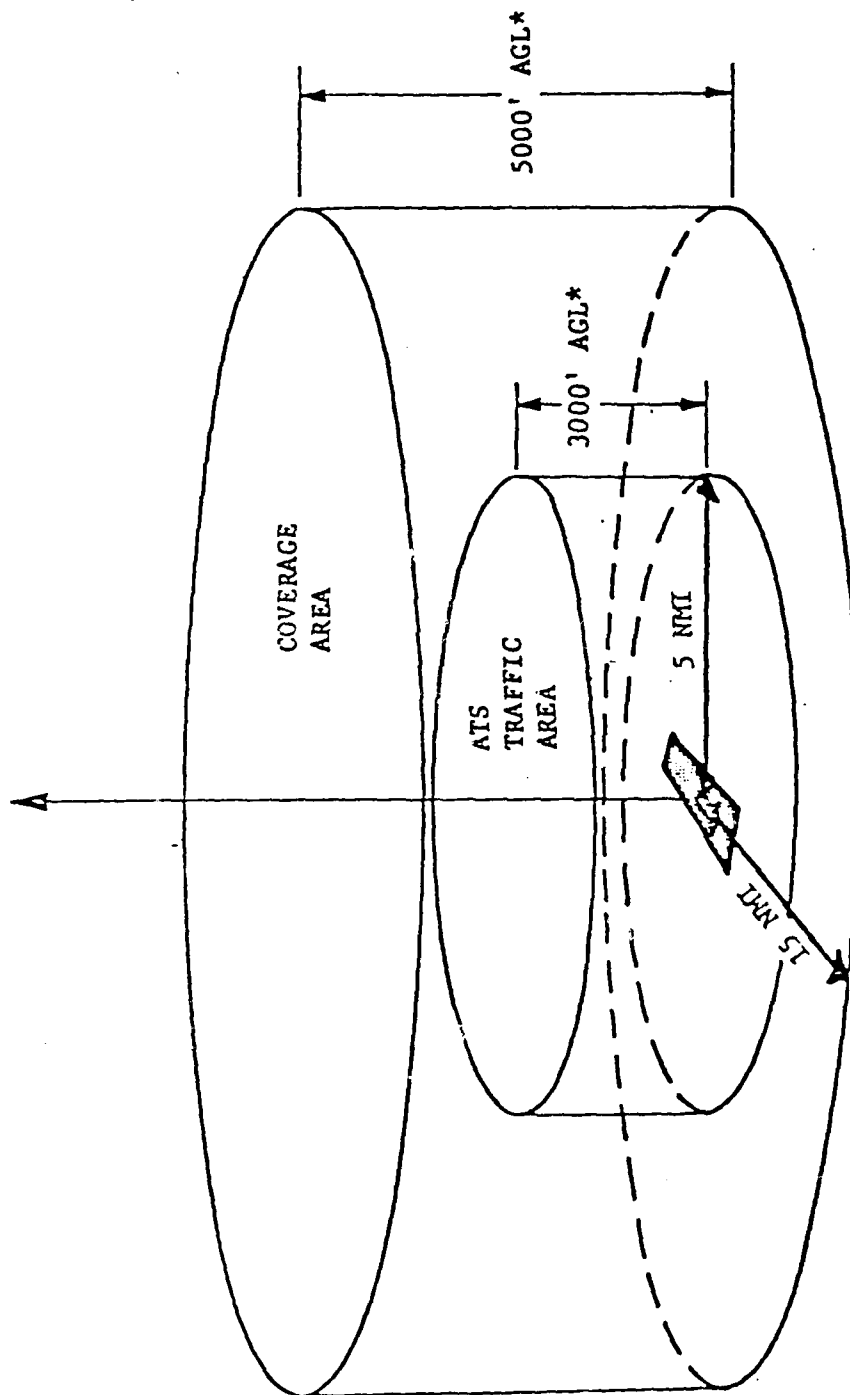

*AGL - ABOVE GROUND LEVEL

ATSSERVICE REGIONS [4]

Figure B-7

may be necessary to back up the ATS beacon surveillance system with a primary radar.

The technology for providing high levels of reliability and availability in ATS is available, but the cost of building ATS will be sensitive to the levels selected. Very stringent requirements may not be applied because in the environment envisioned for ATS it will be possible to revert back to non-tower procedures with little impact on airport operations. A broadcast from the ground computer announcing that ATS is not operational may be adequate.

ATS is based on the use of broadcast information that all ATS participants can hear. Some of the ATS messages may be transmitted to an aircraft via the DABS data link. It is not yet clear how a reasonable mix of data link messages and broadcasts can be achieved at an ATS airport. A block diagram of the elements of automated terminal service (ATS) is shown in Figure B-8.

Over the period 1964-1972, 54% of all mid-air collisions occurred at uncontrolled airports resulting in 17% of the total fatalities. [4] Five of the airports where collisions occurred were served by certificated route carriers. A potential role for ATS is to extend service to airports

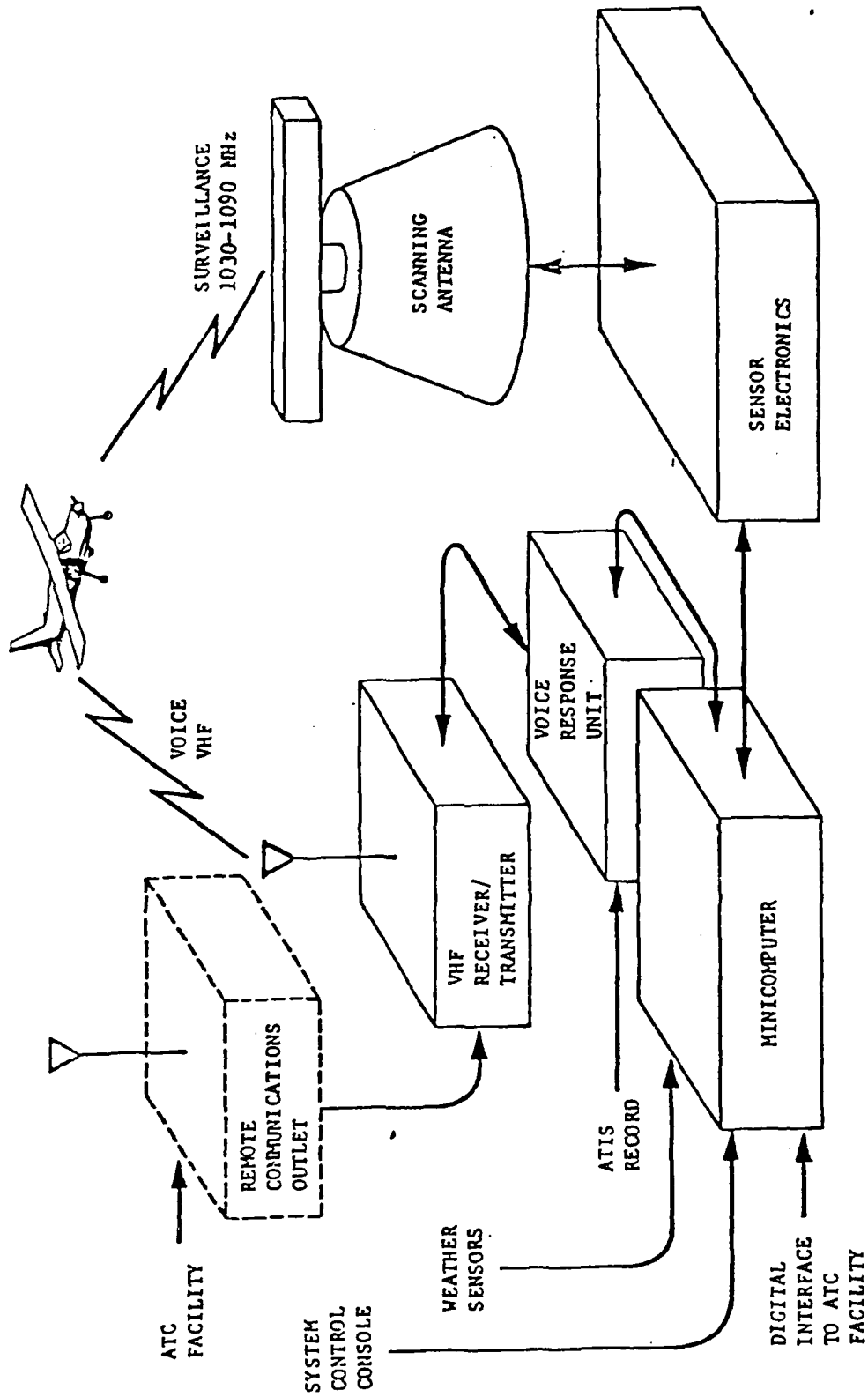

ELEMENTS FOR AUTOMATED TERMINAL SERVICE [4]

Figure B-8

where a manned control tower is not justified, but additional safety is desired. None of the presently defined system elements of the FAA separation assurance program (e.g., Conflict Alert, IPC, BCAS, or even the discontinued ACAS) is effective in the traffic pattern environment.

While not requiring the availability of other major new elements of the ATC E&D program, ATS is compatible with and can take advantage of those developments. Particular items include:

- o ATS and Intermittent Positive Control (IPC)
The IPC cockpit display for collision avoidance and proximity warning information can be driven by a DABS-equipped ATS site using a variant of the special ATS traffic pattern threat detection logic. This would provide high integrity communication to the pilot for the most critical ATS threat detection message. Various approaches exist for coordinating the transfer of service between ATS and a "surrounding" IPC area serviced by a standard DABS sensor.
- o ATS and Beacon Collision Avoidance System (BCAS)
The BCAS system also relies on ATC transponder equipage. BCAS is planned to have ground commanded threat detection desensitization and inhibit logic for use in terminal environments. The DABS-equipped ATS site could also command these functions.

2. Aircraft Conflict Detection Logic In ATS

A pattern dependent logic (in which detection thresholds are selected, based on the pattern state of the aircraft in the conflict pair) is required to perform effective threat detection in ATS. To be effective, logic must yield

sufficient warning with acceptable alarm rate in the pattern. [4] Criteria used in determining that a conflict exists include horizontal tau, miss distance, range, and altitude separation. With the exception of altitude separation, these criteria are all in the horizontal plane.

A brief description of the criteria follows:

- o Horizontal Tau (TAU) - This is a measure of the time to collision in the horizontal plane. Typical estimator are tau (range over range rate), modified tau, time to closest approach, and time to a separation standard. Each has particular advantages in determining conflict status.
- o Horizontal Miss Distance (HMD) - The minimum horizontal separation that will occur between aircraft in the future if both maintain constant horizontal velocity vectors.
- o Range (R) - The current horizontal separation between aircraft.
- o Altitude Separation (ALT) - The current vertical separation between aircraft.

A conflict is declared if tau is positive and less than a given threshold and the predicted miss distance is less than its corresponding threshold, or the range criterion is below its threshold. Other factors affecting these thresholds might be day/night operations, traffic density, IFR/VFR, or whether either aircraft is uncooperative (i.e., unlogged). The detection logic is not executed when both aircraft in the pair are below 200 feet.

B. The Automated En Route Air Traffic Control (AERA) System

The AERA system is meant for the busy en route environment where central management of traffic flow to accommodate the terminals that are being fed is important. [3] AERA involves a very high level of automated decision making.

AERA is presently at the basic simulation stage. Over the next two years this simulation will be improved by adding more intelligence and features to permit real-time testing of different controller/computer interface alternatives.

AERA is a flight plan based system, only flow management, weather, and conflict avoidance act as constraints on flight. The design philosophy is to make the system as flexible as possible for the user.

In AERA, the computer monitors aircraft progress. It projects flight paths and generates a conflict-free path for each aircraft. On the basis of this conflict-free flight path, the computer generates routine clearances. AERA requires a data-link to transmit these clearances and can be used for other pilot/computer communication.

AERA is intended for the en route airspace where flow management is important. In other regions, where the traffic is less dense and, perhaps more importantly, flow management is not

quite as critical the separation function provided the controller might be replaced by a system that provides automated collision avoidance of a tactical nature. One can envision a system where no ATC approval is required for flight. If, for example, a pilot wants to change altitude, he could do so without requesting a clearance.

C. Non-Flight Plan Based System

The non-flight plan based system concept is for the less busy, perhaps low altitude en route environment. A non-flight plan based IFR alternative as a tactical system is envisioned where computers on the ground or in the aircraft generate traffic advisories and collision avoidance commands. This activity is just entering the concept formulation phase.

Safety in a non-flight plan based system would be provided by a system on the ground or in the aircraft that continually monitors the surrounding airspace. This system provides traffic advisories and, when necessary, conflict avoidance commands.

The type of avionics required for this service will depend on the specific system that is used for surveillance and separation assurance. If a derivative of the ground based ATARS is used, a DABS transponder and a display will be needed. The display could be a simple device with an outer ring of proximity

warning lights and a set of crosses and arrows for "do" and "don't" commands. If an airborne system such as BCAS is used, the aircraft will have to be equipped with an appropriate interrogator, perhaps a computer on-board, and a display in the cockpit, and a DABS transponder.

D. FAA Ground Based Separation Programs - Conflict Alert

Conflict Alert is a groundbased automated aid which brings to the controller's attention any tracked flight pairs which are predicted to have neither sufficient horizontal nor vertical separation within the next minute or so. Implemented initially "en route", a terminal area version is now being developed and evaluated. [5]

When aircraft are projected to get closer than minimum separation standards, their identification tags on the controllers' radar scope will flash or blink to alert the controller. [6] In addition, a clear text message will appear on the scope advising the controller of the identification of those aircraft that are in conflict while the computer scans all traffic every 6 seconds.

Conflict predictions are made by the program upon analyzing altitude (Mode C/reported/assigned) and track data (present heading of the aircraft without regard to the Flight Plan Route) and predicting where an aircraft will be two minutes in the future.

Visualize a cylinder of airspace and an aircraft within the center of this piece of airspace (Figure B-9). The dimensions of this cylinder are five miles across and 1,000 feet below and above the aircraft at altitudes above 29,000 feet. At 28,000 feet and below, vertical dimensions become 500 feet above and below.

Any time these two cylinders of airspace are projected (computed) to touch within two minutes (Figure B-10), an alert will flash on the radar scope. Furthermore, an immediate alert will flash any time the cylinders of airspace are penetrated vertically by approximately 300 feet. The system is being used above 12,500 feet MSL in controlled airspace where all aircraft are required to have a functioning altitude reporting beacon. Upon detection of a conflict, the controller provides the actual separation commands to the aircraft via normal VHF radio.

Basic metering and spacing is an automated groundbased aid which computes suggested speed and heading commands for arriving aircraft within the terminal area, thus assisting the arrival radar controller in sequencing and spacing arrivals to the runway [5].

IV. AIR TRAFFIC CONTROL RADAR BEACON SYSTEM (ATCRBS) AND DISCRETE ADDRESS BEACON SYSTEM (DABS)

Since these two basic systems form important elements around which cooperative CAS concepts have been formed, a brief description of each follows: [7]

CONFLICT ALERT CONCEPTS

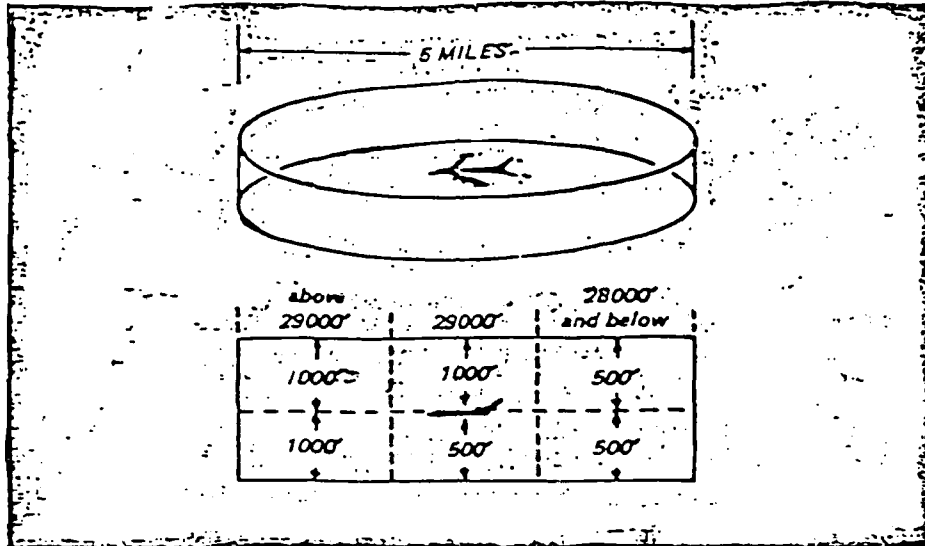

Figure B-9 [6]

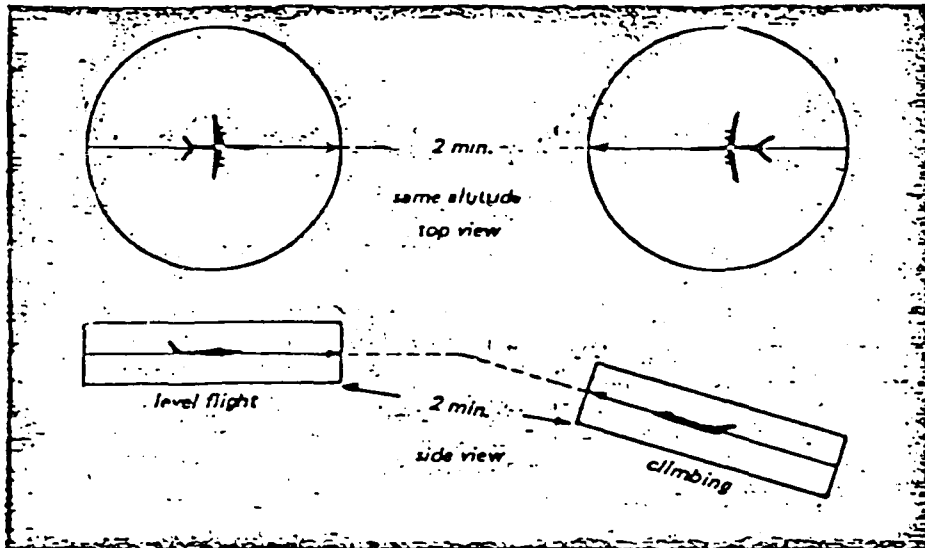

Figure B-10 [6]

A. ATCRBS System

The ATCRBS consists of airborne transponders, a ground-stationed interrogator, an antenna system, and processing equipment. ATCRBS interrogations are transmitted at the rate of several hundred per second using a narrow beam (1° - 4°) antenna which rotates to cover a full 360 degree azimuth several times per minute.

All aircraft equipped with ATCRBS transponders within line-of-sight and located in the antenna mainbeam can reply. Interrogators may elicit 20 or more replies from each aircraft within the mainbeam. The principal information determined from the replies consists of aircraft range, azimuth, identification, and altitude. The system processor automatically displays this information for use by the air traffic controller.

The increase in air traffic and number of ground interrogators has in turn increased demands on this system, thus taxing its viability, and has led to the development of DABS as its replacement. The overall cost advantage of this approach shall be weighed against the significant disadvantages of utilizing ATCRBS (CAS must use the same basic signal formats, and it must not seriously degrade the basic ATCRBS performance). [2]

The ATCRBS reply signal consists of a 12 bit pulse amplitude

modulated message between two framing pulses separated by about 21 microseconds. The spacing, of the individual 0.45 microsecond reply pulses, is 1.45 microseconds. The 12 bit message is coded with aircraft altitude or identity depending on the pulse spacing of the interrogation. The long 21 microsecond pulse reply can lead to a condition called "garble", defined as a condition occurring when two aircraft whose replies come from ranges that are approximately equal (within 1.6 nmi) overlap and cause mutual interference. Garble caused serious problems in the ATCRBS until side lobe suppression was added to the interrogator antennas and "defruiters" were employed. Side lobe suppression prevents all transponders except those in the main lobe from responding and defruiters permit decoding correctly when up to about three transponders are mutually interfering.

B. DABS System

DABS is being designed to be compatible with the existing ATCRBS, because the transition must be gradual and the air traffic control (ATC) function must be maintained while both ATCRBS and DABS transponders and interrogators are in use. [7]

In addition to the ATC function, the DABS system has the capability of providing a data link for implementation of ATARS, an automatic groundbased conflict detection and resolution service.

The principal difference between ATCRBS and DABS is the use of discretely addressed interrogations by DABS. Since each aircraft is assigned a unique address, it will reply only to its unique address once a track has been initiated. By tracking each aircraft and using the unique address capability, DABS is able to schedule interrogations both to minimize uplink transmission rates and prevent synchronous garble. Compatibility is maintained between DABS and ATCRBS systems, since these must work in the same environment.

V. ALGORITHMS FOR CONFLICT AVOIDANCE SYSTEMS

One of the first major steps in organizing the development of an aircraft Conflict Avoidance System, was the publication of ANTC-117 Report. This document was first issued in October 1966, and has been revised a number of times subsequently. [8]

A number of defects and limitations have been uncovered as a result of extensive prototype testing of systems developed by various vendors and computer simulations. In particular, the parameters pertaining to dense traffic, which are imperative to allow safe separation, have not been defined with certainty.

A. Types of Algorithms

The algorithms which provide alarm criteria are of two types:

(1) those based on the separation distance (range), R , and separation rate (range rate), dR/dt ; and (2) those based upon the altitude difference Δh between aircraft and altitude rate dh/dt of an individual aircraft. [2]

The dR/dt criteria alone should be sufficient to provide the alarms needed for protection against collision, however, the use of altitude data is required to reduce the threat volume, and hence the alarm rate, to manageable proportions and also to determine the proper direction for vertical avoidance maneuvers.

The measurement of R , dR/dt , and (Δh) is accomplished by means of radio communication between aircraft. The arrival time of a communication signal is used to calculate R , while dR/dt is obtained from a measurement of the doppler shift, although the recent tendency in CAS designs has been to obtain dR/dt from the incremental change in measurements of R at two different times.

Each aircraft measures its own altitude via barometric altimeter and communicates it in incremental digital steps of 100 feet each to other aircraft. Each CAS-equipped aircraft measures its own altitude rate for its own evaluation, but does not communicate this data to others.

The ANTC-117 report requires that each aircraft limit its horizontal acceleration to $\frac{1}{2} G$, its vertical acceleration to $\frac{1}{2} G$.

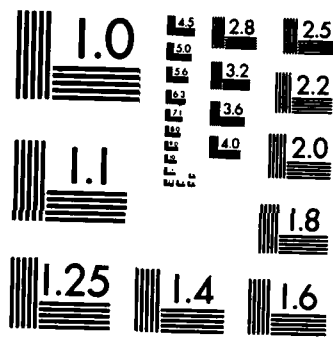

MICROCOPY RESOLUTION TEST CHART
NATIONAL BUREAU OF STANDARDS-1963-A

and its vertical rate to 5,000 ft/min. This implies a maximum relative horizontal acceleration of 1 G and vertical acceleration of $\frac{1}{2}$ G, and a maximum vertical separation rate of 10,000 ft/min between two aircraft.

Time allowances have been made for pilot reaction nominally a few seconds, but as much as six seconds, assuming pilots will act without procrastination; for aircraft response, typically 1-2 seconds; equipment delays assumed not to exceed 3 seconds, the epoch or time multiplex cycle of the technique given in ANTC-117; and finally about 15 seconds for the escape maneuver.

B. Primary Threat Criteria

In the early days of CAS development, it was proposed that an R, dR/dt algorithm be based upon the quantity tau, defined by:

$$\text{tau} = \frac{R}{dR/dt}$$

representing the time to collision for two aircraft on a non-accelerating collision course. It has since been realized that, because of measurement errors and the possibility that aircraft may be accelerating, a modification of this idea is necessary. Thus, ANTC-117 has adopted two alarm algorithms having the same algebraic form sometimes known as modified tau criteria:

$$R + \text{tau}(i), \frac{dR}{dt} < R_i$$

tau (i), and R_i are designated constants which take on different

values for the two cases: $i = 1, 2$.

In the first algorithm, known as the tau(1) alarm criterion, the designated constants have the values: $\tau(1) = 25$ sec, $R_1 = \frac{1}{4}$ nmi (1520 ft). In the second algorithm, known as the tau(2) warning criterion, the constants have the values: $\tau(2) = 40$ sec, $R_2 = 1.8$ nmi (10,940 ft).

An analysis of a CAS employing range and range rate indicated that the form of the equation used in ANTC-117 was valid, however, R_0 should be set equal to $\frac{1}{4}U(\tau)^2$ plus measurement errors, where U is the sum of the magnitudes of acceleration of both aircraft and τ is the time before collision at alarm. If R and dR/dt satisfy the tau(i) criterion, vertical maneuver commands are issued, so that the aircraft at the higher altitude climbs, while the aircraft at the lower altitude dives until both aircraft are separated by a safe distance. If three aircraft are involved, the aircraft in the middle maintains its course, neither climbing nor diving.

The tau(i) criterion has been modified further by the addition of a minimum range criterion, the purpose of which is to protect against the hazard in case of dR/dt equal to or near zero, since it was felt that with the presence of acceleration and measurement errors, the time available for maneuver might be reduced below

an acceptable minimum in this circumstance. Thus, an alarm also occurs with the same commands as for tau(i) alarm if

$$R \leq R_m$$

where the minimum range R_m has been designated as $\frac{1}{2}$ nmi (3040 ft). The latter alarm will be referred to also as a tau(i) alarm.

C. Altitude Criteria

The tau alarms are implemented only if the encountering aircraft are co-altitude, or it is predicted that they may become co-altitude, where "co-altitude" is defined to mean that their vertical separation is less than 600 feet at altitudes below 10,000 feet and 800 feet at altitudes above 10,000 feet. This definition of co-altitude is based upon: (1) and altimeter error allowance of ± 150 feet (3 sigma (1)) below 10,000 feet and ± 250 feet (3 sigma (i)) above 10,000 feet; (2) the assumption that a safe vertical separation between aircraft is 150 feet; and (3) what is intended as an allowance for an undetected vertical drift rate of 500 ft/min.

VI. INITIAL CAS DEVELOPMENT BY FAA

The FAA issued a contract in early 1970 to IDA (through ARPA), for the design, development and testing of three cooperative, airborne, collision avoidance systems (CAS's) developed by Honeywell, McDonnell Douglas, and RCA, respectively. [10]

IDA's task is to analyze how well each system performs in the FAA's 1982 forecast of air traffic density in the Los Angeles basin.

The forecast was released by the FAA on 27 April 1971. This forecast was superseded by the 1982 Los Angeles Basin Standard Traffic Model prepared by the MITRE Corporation, April 1973. According to the task order, the systems were to be evaluated to the extent that they all use the threat logic described in the ATA/ARINC Characteristic No. 587-2 (9/20/71), also called the ATA ANTC-117 Specification.

The McDonnell Douglas CAS, uses the time/frequency technique employing one-way ranging and doppler measurement. The other two systems utilize interrogator/transponder (beacon) techniques and two-way measurements. All three systems use altitude data for threat evaluation. In addition, the two beacon systems use altitude filtering to reduce undesired responses.

A. McDonnell Douglas Electronics Company (MDEC) Time/Frequency CAS

Since the early 1960's, for its own applications in flight testing of military fighter-interceptors (in particular following a fatal accident and other near-miss incidents), a CAS unit called EROS was developed by MDEC based on time-frequency techniques. [2]
The application of EROS in testing aircraft by McDonnell Douglas

has been the only true CAS operational use of the Time-Frequency or other techniques.

McDonnell Douglas Electronics Corporation has developed a special "MiniCAS" for FAA applications and it consists of two versions, one for air carrier aircraft application and the other for general aviation. [11] , [12]

The "MiniCAS" system employs time differenced range measurements ($\Delta R / \Delta T$) to digitally derive range-rate. Special $\Delta R / \Delta T$ units, which interface with air carrier type CAS were also developed. Both versions of the airborne CAS employed full tau-threat evaluation logic. The newer $\Delta R / \Delta T$ logic provides better range rate accuracy than the original Doppler method.

The MDEC time/frequency CAS is a cooperative time division multiplex radio frequency system which protects equipped aircraft against collision with any other similarly equipped aircraft. [11] [12]. In dense traffic this concept provides interference free data exchange for up to 2,000 participants. The technique requires precise time synchronization and controlled frequency switching of air and ground equipment. A list of system elements and their major functions are identified in Table B.1. Four carrier frequencies are used: 1600 MHz, 1605 MHz, 1610 MHz, and 1615 MHz, which are stepped in a cyclic manner every 1.5 milliseconds (length of a basic time slot).

TABLE B.1 CAS EQUIPMENT DESCRIPTION SUMMARY [11]

| EQUIPMENT | MAJOR FUNCTIONS | MAJOR ITEMS |
|---------------------------------|--|--|
| Ground Station (G/S) | System Timekeeping Synchronization Service Monitoring/Flight Following Test | Master Channel Slave Channel Antennas (3) |
| Fly-By-Sync (FBS) | Obtain U.S.N.O. Time Transfer Sync to G/S Monitor G/S Calibration Monitor G/S Performance Operate as CAS Provide Hierarchy Sync | "Flying Clock" Freq. Std. Clock Stby Pwr. Sup. Control Panel C.A.U. |
| Model 2000 CAS | Commercial Airline CAS Provide Hierarchy Sync Provide Ground Beacon CAS Operate with FBS | C.A.U. Maneuver Indicator Antennas (2) $\Delta R/\Delta T$ Unit |
| $\Delta R/\Delta T$ Unit | Provide Digital Range Rate for C.A.U. instead of Doppler | Packaged as external unit for evaluation |
| MiniCAS | General Aviation CAS with $\Delta R/\Delta T$ and TAU Logic | Pilot's Display is integral with Unit. Antenna (1) |
| Instrumentation (Photopanel) | Real Time Displays Photographic Recording Monitor G/S Performance Monitor C.A.U. Performance Monitor MiniCAS Performance Provide Range/Altitude for Join-up and Stationkeeping | Own Slot Display Data Slot Display Controls. |

Ground stations, synchronized to a single source of master time, provide first order synchronization support to all airborne units within communication range. Extension of ground station time is provided through time-hierarchy relay chains to all users by scheduled airline users equipped with ARINC Characteristic 587 Collision Avoidance Units. Provisions are made in ARINC Characteristic 590 and ANTC-117 for limited level classes of cooperative equipment intended for use by small commercial airline, general aviation, and military users. One of the major simplifications in the limited level systems is the omission of the time-hierarchy function. These systems can obtain T/F synchronization from hierarchical systems, but cannot relay it to others.

In less dense traffic areas, not covered by ground stations and beyond the reach of the aircraft sync relay, CAS protection is provided by a secondary asynchronous mode (Back-Up Mode). An MDEC Commercial Airline CAS configuration is shown in Figure B-11.

The original MDEC version was called MicroCAS. Its threat logic was based on fixed range alarm boundaries. It was concluded by ARINC that the full tau-threat logic used in the air-carrier CAS would be more suitable for all classes of users.

Tau-threat logic requires measurement of range and range rate

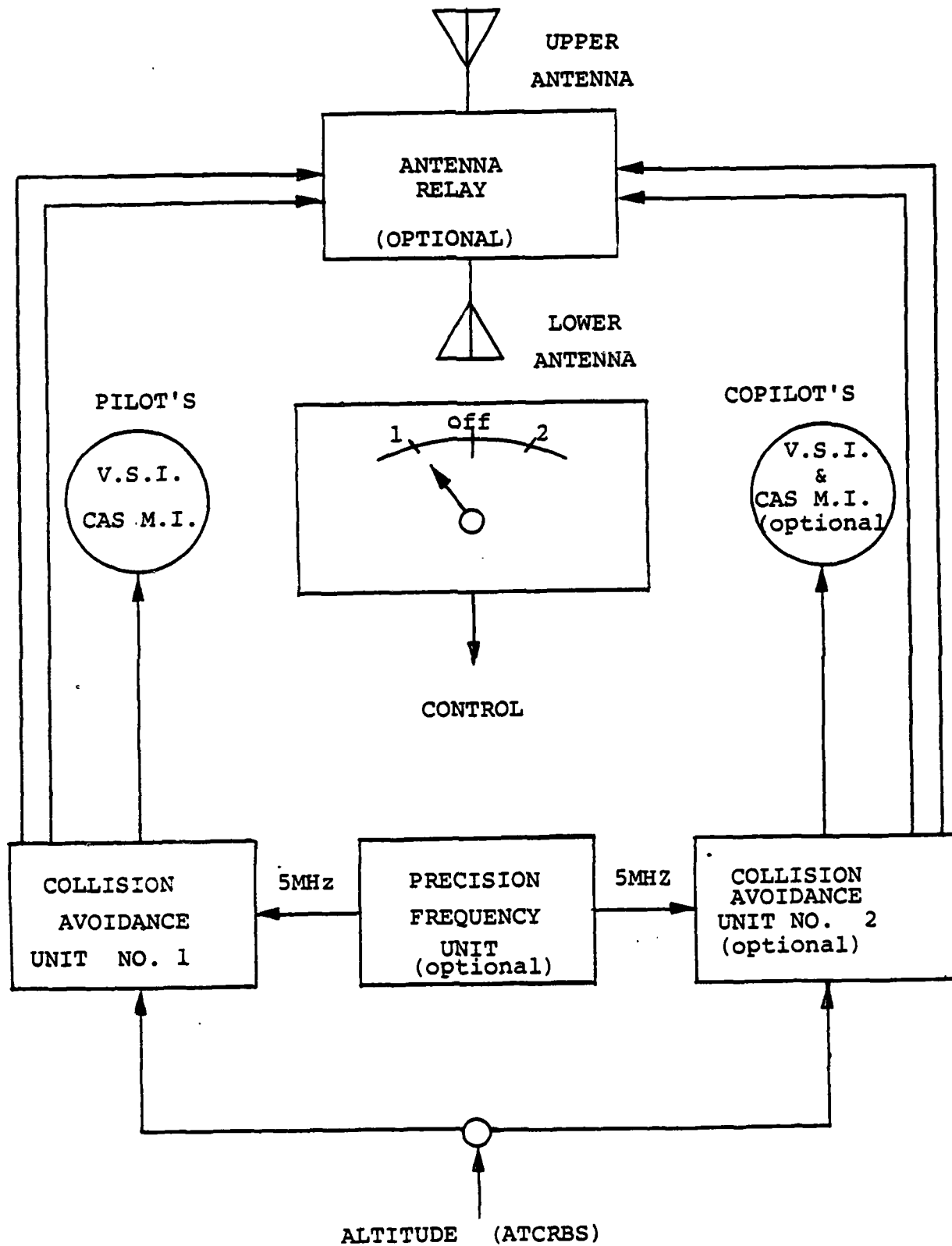

[11] COMMERCIAL AIRLINE CAS CONFIGURATION

Figure B-11

to derive tau (time to closest approach). Until recently, range rate was derived from the Doppler shift on the carrier frequency of the 200 microsecond CAS range signal. This requires highly accurate and stable (spectrally pure) frequency generation throughout the entire transmitting and receiving subsystem. The cost of this type of frequency control for general aviation CAS would be prohibitive. However, with the development of inexpensive medium scale integrated circuits for digital logic, the previously discarded approach of measuring range rate by range differencing became practical. This technique called $\Delta R / \Delta T$ (delta range divided by delta time), therefore, makes full tau-threat logic practical for general aviation MiniCAS.

Likewise, the $\Delta R / \Delta T$ concept, when used for the air-carrier type CAS, allows a significant reduction in the cost and complexity of the RF subsystems.

The principal problem uncovered with the McDonnell Douglas T/F CAS, and it is a problem that exists in ANTC-117 since the McDonnell Douglas conforms to that characteristic, is that at low range rates, but sufficiently high that the minimum range alarm does not apply, measurement tolerances permit excessive delay in warnings. [2] In the modified CAS using successive range measurements to estimate range rate, the random error has been reduced by an order of magnitude, but the computation of the

estimate is biased. The latter bias results in earlier alarms and a bigger protection volume than specified in ANTC-117.

B. Honeywell - Collision Avoidance System

The Honeywell CAS utilizes a transponder ranging technique. It requires no time synchronization between participating aircraft, since the system has an interrogation and a response mode of operation. During the interrogate mode, a four-pulse altitude coded waveform is transmitted. This waveform requests other aircraft within communication range and within a specified altitude band (typically ± 700 ft of an encoded reference altitude) to respond. An aircraft responds by transmitting a single 100-nsec pulse, which is delayed a fixed amount with respect to the received interrogation waveform.

Honeywell developed two versions of its Collision Avoidance System, AVOIDS-1 for high performance aircraft and AVOIDS-2 for low performance aircraft. Both Honeywell systems use the ATA collision avoidance logic.

The Honeywell CAS [2] , [10] is an asynchronous system, utilizing beacon techniques and operating on a single frequency. Short, 100-nsec pulses are used for interrogations and replies, and a low duty cycle is used to reduce mutual interference among interrogators. Range between aircraft is determined by measuring

the two-way propagation delay. During a threat evaluation period of three seconds, seven range measurements are made. These data are then processed, using the ATA criteria, which permit the evaluation of threatening encounters. (see Figures B-12 and B 13).

The interrogation waveform consists of four short pulses. The pulses of the first pair in an interrogation group are separated by 500 nanoseconds and the pulses of the second pair are separated by 600 nanoseconds. It is encoded with a reference altitude, biased from the barometric altitude of the transmitting aircraft.

Interrogations are addressed to altitude layers by varying the separation between the two pulse pairs in accordance with the altitude layer being addressed. The separation equals a fixed delay of 32.5 microseconds plus 2 nanoseconds per foot referenced to -1200 ft MSL. The transponders reply to interrogations addressed to the transponder's altitude \pm 650 ft.

The Honeywell CAS transmits a sequence of probes addressed to different over-lapping layers so as to logically determine the altitude of the replying transponder relative to the altitude boundaries of the ATA altitude criteria.

In each of the altitude layers that the interrogator probes, the replies are stored in a register with a resolution of 50 ft.

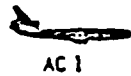

AC2 RECEIVES INTERROGATION FROM AC1
 AC2 COMPARES ENCODED ALTITUDE TO OWN ALTITUDE.
 AC2 RESPONDS IF IT IS WITHIN THE INTERROGATED
 ALTITUDE BAND

AC1's INTERROGATION CONVEYS AC1's
 REFERENCE ALTITUDE



AC1 RECEIVES RESPONSE FROM AC2 AND BY
 SUBTRACTING THE FIXED DELAYS DETERMINES
 THE RANGE TO AC2. THIS DATA IS THEN COMPARED
 WITH DATA GATHERED PREVIOUSLY. AC1 FLAGS AN
 ALARM IF SUCCESSIVE COMPARISONS INDICATE THAT
 A THREAT (TAU ZONE 1 OR 2) EXISTS.

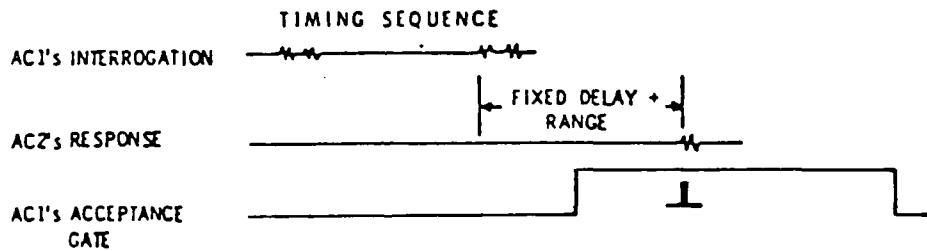
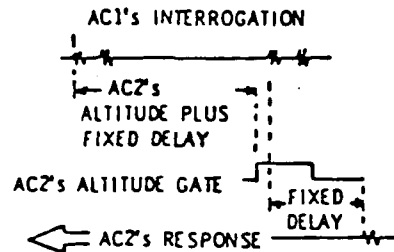

Interrogation/Response Sequence of Events (Source: Ref. 1) [10]

Figure B-12

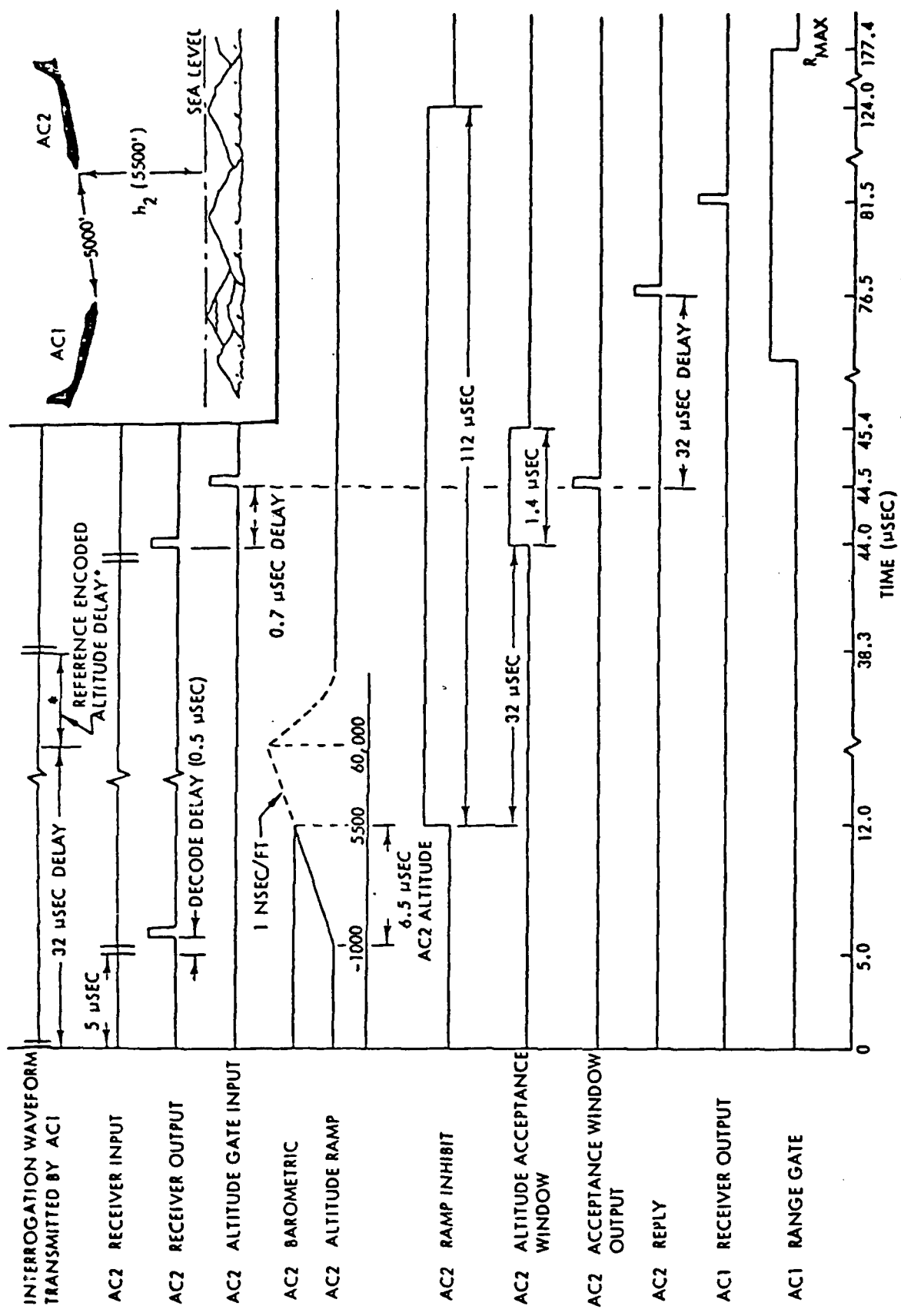

* ASSUMED TO BE 6.3 μSEC FOR THIS FIGURE

Timing Diagram for Interrogate/Response Sequence [10]
Figure B-13

To form a track the CAS interrogator fills eight such registers at half second intervals and then processes the data in the eight registers to identify those that form tracks with characteristics that are identified as satisfying the ANTC-117 threat logic.

Generally, AVOIDS-1 and AVOIDS-2 have adequate communications range for the aircraft speeds for which they are designed. The number of alarms caused by pseudo-tracks (PT's) may not be bothersome to pilots of CAS-equipped aircraft, however it may be high enough to disturb ground controllers in the air traffic control (ATC) system. The inhibit/suppression logic can occasionally reject a warning or delay it to a point where the situation becomes dangerous. The inhibit/suppression logic which was incorporated primarily to suppress PT's is effective in reducing the generation of PT's; however, this logic can also cause threatening targets to be ignored. Honeywell has essentially overcome the ghosting problem in their last version of the CAS design by increasing the number of data points in a target track from 7 to 8 and by correlating tracks formed in successive epochs (3.5-4.0 second periods).

There still persists a small residual ghosting problem in the form of the incidence of early alarms on targets at any range with closing range rates slightly below the minimum necessary for an alarm.

Blockage from real interrogations and false interrogations* caused by fruit can be serious; (synchronous and asynchronous interfering replies from responders in response to probes by interrogators) but it can be reduced to an acceptable value of 3% by implementing interpulse amplitude comparison, varying communications range with altitude, reducing the altitude-ramp inhibit time, and improving the two-pulse decoder resolution. Without these changes, the blockage might be 10 to 20 percent, which is unacceptable.

The system does not provide data transfer between aircraft as provided in the ATA specifications. This transfer should be incorporated, particularly if it is necessary to advise the air traffic control system that aircraft are maneuvering or deviating from ATC instructions.

A real target with a range rate near the minimum closing threat range rate can contribute to the generation of a track in two epochs and when combined with other target and fruit replies form a complete false track. In most cases, such targets become true threats two or more epochs later, and therefore only create an alarm earlier than they should. Since the Honeywell tracker uses an eight point data sample over a 3.5 second interval to form the track from which target characteristic range and range

*a non-valid interrogation caused by the interactions of multiple interrogations.

rate are derived, the computational bias is small and the magnitude of the early alarm problem is less severe than the problem of the computation bias in the other systems using similar 3-6 second epochs.

Introduction of aircraft identity in the transmissions, when data transfer is implemented, will also solve the track association problem leading to PT's and eliminate the need for inhibit/suppression logic.

C. RCA SECANT Equipment VECAS and VECAS-GA

SECANT is an acronym meaning Separation and Control of Aircraft using Nonsynchronous Techniques. It is RCA's beacon-based CAS [2] , [13] equipment which exists in several levels of mutually compatible units ranging from a simple transponder which provides no indication to pilots, but signals necessary for other equipment, to the highest level, completely asynchronous, cooperative collision avoidance equipment. RCA has essentially overcome the effects of mutual interference by using several techniques. The technology that contributed to this design was the advanced digital circuitry and components which now permit the storage of large quantities of data.

Originally, RCA proposed a SECANT CAS that included bearing measurements and proposed horizontal as well as vertical escape

maneuvers. Subsequently, RCA proposed and built for FAA test a SECANT CAS intended to conform completely with ANTC-117 logic which specifies only vertical maneuvers. This version was called SECANT VECAS (Vertical Escape CAS). Two versions have been proposed; so-called "full" VECAS for MACH-1 aircraft and VECAS-GA for lower performance aircraft.

1. Altitude Encoding

The interrogation waveform of VECAS and VECAS-GA is two 1-microsecond pulses separated by a time interval. Altitude is encoded on the time interval as a constant delay plus, a delay proportional to barometric altitude. The interrogators "address" a series of altitude bands by changing the time interval by fixed amounts (2 microseconds) corresponding to changes in altitude of 500 ft. Above 10,000 ft the 2-microsecond increments correspond to a change of 1000 ft; above 30,000 ft a single delay is used.

The transponders reply with a single pulse after decoding the two pulse interrogation, when the decoded 500 ft altitude layer includes the altitude of the transponder to allow only transponders which receive interrogations addressed to their altitude layer to respond. Altitude Coding reduces the number of aircraft that respond to those of the addressed 500 ft altitude layer and eliminates garble from transponders

at the same range but different altitude layers. Aircraft with large altitude separations from a given interrogator do not constitute a threat and are never addressed; altitude coding reduces fruit.

2. The Frequency Multiplexing and Correlation

Full VECAS operates on 24 channels separated by 1 MHz; 12 of the channels are used above an altitude of 10,000 ft and 12 below 10,000 ft.

Within an altitude band above and below 10,000 ft, each group of 12 frequencies is divided into two subgroups of six frequencies each, assigned to operation either on the top or the bottom antenna of the aircraft. Finally, within each subgroup of six frequencies, two frequencies are assigned for probes and four for replies. Each probe has two reply frequencies associated with it which permits a transponder to superimpose coded messages on the replies. A transponder receiving a probe on a given frequency will respond on one of the two associated reply frequencies.

The VECAS interrogator cycles through a sequence of steps: search for targets, tracking and fine range measurement, altitude decoding and threat estimation for each 500 ft altitude layer, which proceeds until all layers from

which threats can develop are covered. The complete process to cover up to 10 layers (5000 ft) takes a maximum of 4.26 seconds.

During this search, the interrogator sends a series of jittered pseudo randomly coded pulses on the two respective probe frequencies with a nominal period of 1 millisecond. Replies from a target transponder will be correlated with the probe frequencies. Valid replies are summed as "plus ones" in a counter. There is a counter for each range bin. If a reply is received on a frequency associated with the other probe frequency, it is subtracted in the counter. Fruit replies, i.e., those stimulated by probes of other aircraft interrogators in the vicinity, the counter on the average will be zero, whereas valid replies should always increase the count. If the counter exceeds a threshold value at the end of the series of probes, a target is declared in the appropriate range bin. An older version used 25 probes with a threshold of 10. This detection mechanism is very reliable with respect to false detection and false dismissals. Only 13 probes are utilized in the latest CAS with the same threshold resulting in adequate, but poorer, performance. After targets are detected in the range correlator, the VECAS logic assigns one of 32 trackers

to acquire each target in the occupied range bins. The number of trackers for VECAS-GA version have not yet been designed. After a target had been acquired the average of the ranges measured for each of a series of 31 probes is derived. A range measurement with 31 more probes is repeated after a delay of about 0.37 seconds. The difference between these two measurements is used to estimate the range rate for use with range in the ANTC-117 collision threat logic.

Since the altitude coding on the two-pulse probe is inadequate for the ANTC-117 threat logic, RCA codes the replies from each transponder with the transponder's altitude using a binary selection of one of the reply frequencies associated with each probe frequency. Altitude is coded to 100 feet as in the ANTC-117 characteristic. To decode the transponder altitude, the interrogator sends a sequence of synchronous probes equal in length to the transponder message. In the latest version of VECAS these are used during the first range measurement sequence.

The range search and correlation process is highly reliable in the presence of fruit as probabilities of false dismissal and false alarm of the correlator are insignificant.

The fruit levels have been reduced significantly by reducing the number of probes used for each phase, the gain margins of VECAS-GA have been increased to those of VECAS and the power of the PWI increased to that of the other types. Range rate accuracy has been improved to make it comparable to that specified in ANTC-117. Although the RCA CASS use differential range estimates of range rate, the computational error is small because the time between range measurements is less than 0.4 seconds.

3. Number Of Trackers

Only a few trackers are used in early versions of the VECAS equipments and these trackers were assigned sequentially to the targets detected in the range bins for each altitude layer. When the number of targets in a layer exceeded the number of trackers, a queue develops for each tracker. In dense traffic a single tracker might be required to handle four or five targets. Each target may fill as many as three range bins because of the stretching of its replies by the narrow one MHz filters. If such conditions existed, the time to handle all targets in all altitude layers could be in the order of ten seconds, which is excessive considering total ATA algorithm alarm times that might be less than 25 seconds ($\tau(1)$) or 40 seconds ($\tau(2)$). In the new versions

of VECAS the number of trackers is 32, and the number of bins filled by a single target is less than 2, so that the total time required (less than 4.3 seconds) is determined only by the number of altitude layers probed. VECAS-GA had inadequate detection range margins, but these have been made equal to those of VECAS.

D. Mitre CAS

In this Collision Avoidance System designed by MITRE Corporation, airborne CAS interrogators are proposed to interrogate sequentially several azimuthal sectors by means of switched directional antennas to reduce the garble. The ATCRBS side lobe interrogation signals are used to further separate the population into subgroups.

In ATCRBS the interrogation consists of a three pulse sequence: the first (p_1) and second (p_2) pulses with a fixed separation, and the separation of p_2 and the third (p_3) is coded to indicate the kind of reply message desired: altitude, identity, etc. These pulses have been used to reduce side lobe antenna interrogation in most SSR interrogators by transmitting the p_1 and p_3 pulses on the main lobe antenna and p_1 and p_2 on the omnidirectional side lobe antenna. Based on amplitude comparison of the pulses, the transponder replies if it is in the main lobe.

MITRE CAS will send a sequence of interrogations at different power levels. Each interrogation (except lowest power level) will be preceded by a p_1 and p_2 at the previous level. Effective reception of the p_1 and p_2 pulses will suppress all transponders which have replied to the previous interrogations at lower power levels separating the population into groups.

Even with directive antennas and multiple power levels, there is considerable residual garble in dense traffic. MITRE has been designing a "defruiter" it expects to accommodate mutual interference of up to six mutually garbling transponders. Such performance permits satisfactory operation in all regions except for a few high density terminal areas.

MITRE CAS will have an interrogation rate of about one Hz. Range is measured directly, and altitude can be decoded from the reply message. Starting in the fall of 1975 the FAA carried out tests on a simple version of the MITRE design that does not incorporate the multiple power levels or directional antennas.

E. Litchford CAS

The Litchford CAS is based on the ATCRBS [2], [14] equipment and active interrogation. In its primary mode (passive) the Litchford CAS listens for the secondary surveillance radar (SSR) interrogations and for the stimulated replies from the ATCRBS transponders. The CAS measures and stores the differences

in times of arrival (Δ TOA) of the SSR and transponder signals. The transponder can have any location in an ellipsoidal surface whose focii are the SSR and CAS for maintaining a constant Δ TOA. The altitudes and identity can also be obtained by decoding the transponder messages (ATCRBS Mode C and Mode A replies) by the CAS. (see Figures B-14 and B-15)

The stored data from the interrogations of two or more SSRs can be used by the CAS to determine range and bearing to its intruders. When only one SSR is available, the Litchford CAS in its active mode obtains range and also determines bearing with the Δ TOA data. When there are no SSRs available, the CAS operates only in the active mode and obtains only range. Thus range rate is estimated as in other differential range approaches. In regions in which multiple SSR coverage exists, the traffic density is expected to be highest and the Litchford CAS passive mode can be used without appreciable interference to the basic ATCRBS operation.

In high traffic areas when the Litchford CAS is operating passively with large numbers of SSRs, signals of one transponder stimulated by the SSRs are simultaneously garbled. With a single SSR operating it is unlikely that targets having the same Δ TOA initiate their replies on the same interrogation due to relative angular positions in the SSR beam.

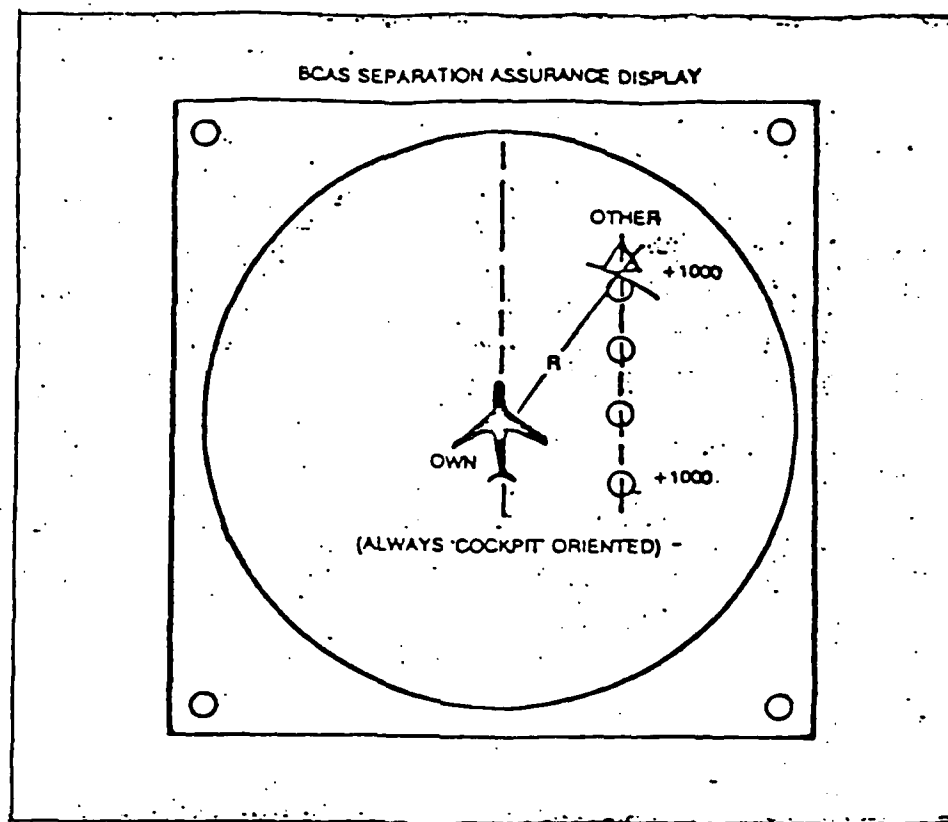

{15}

BCAS has added bearing/bearing-rate to range to the pilot's display. The pilot can judge 100-foot changes of the target's (to his) vertical separation and the track/heading of the target. In the display, "own" always flies "up" the display and is centered; thus enabling "own's" pilot to judge "other's" data to determine whether a threat exists.

BCAS SEPARATION ASSURANCE DISPLAY

Figure B-14

WHAT IS BCAS AND HOW DOES IT WORK?

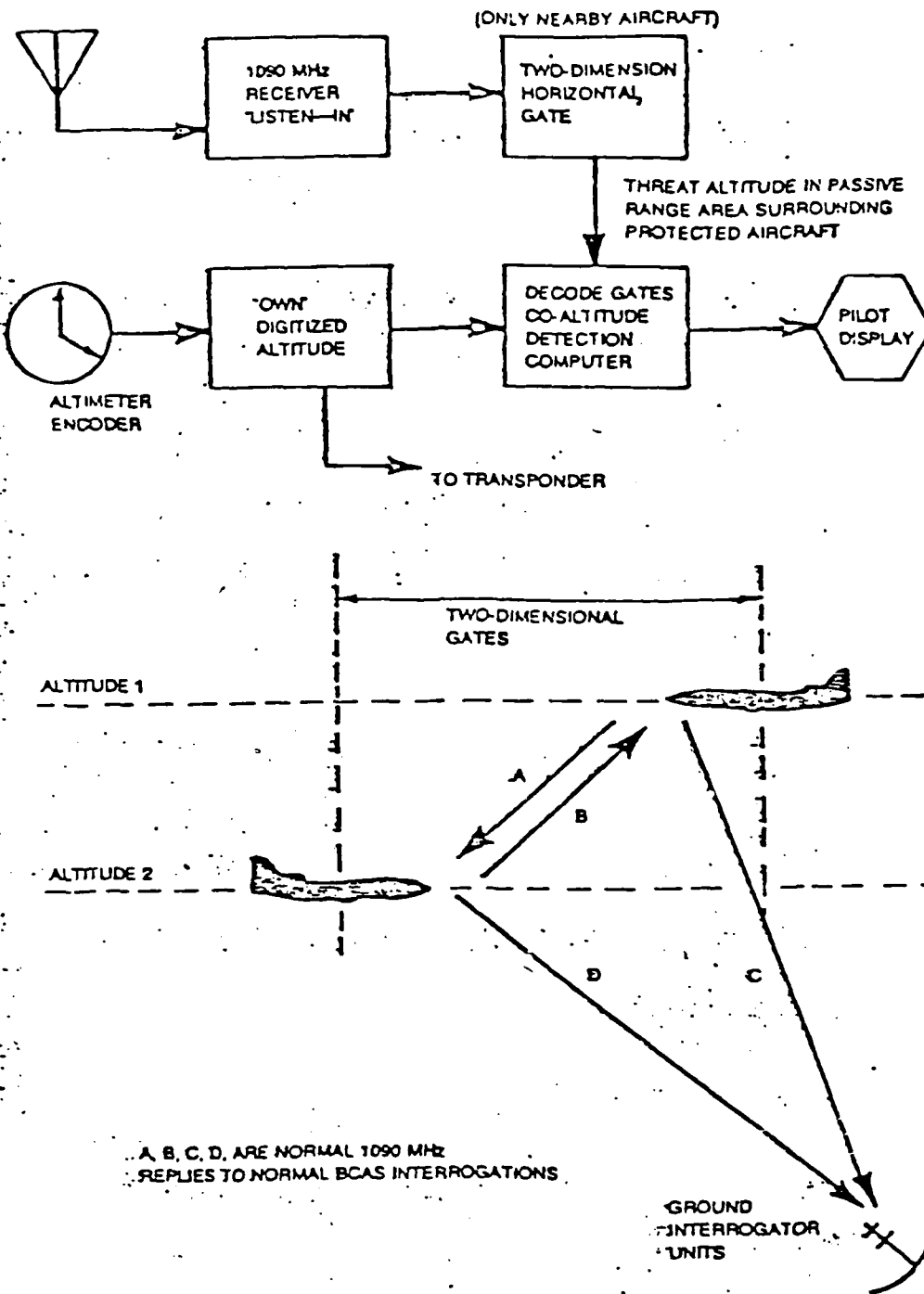

{ 15 } By "listening" to transponder replies from other aircraft and by responding to ground radar station interrogations, an onboard computer can identify and find relative positions of nearby aircraft. Paths A and B in the illustration allow all airspace users to benefit from BCAS concepts for safe separation assurance and avoidance of mid-air collisions.

Figure B-15

The "degarbler" - Litchford CAS also proposes to incorporate a simple "degarbler" allowing tracking interleaved replies. The degarbler would, when all else fails, track the initial pulse of the reply (f_1) or the trailing pulse (f_2). When garble occurs, the Litchford CAS will search through the past data for altitude and identity and continues to track and correlate Δ TOA on the parts of the message that are still available (f_1 or f_2 pulse).

The FAA's ATCRBS network includes about 700 SSR ground stations radiating a narrow interrogation beam (see Figure B-16A) and an omnidirectional sidelobe suppression broadcast on a 1030 MHz uplink to nearly all aircraft in the controlled airspace. The present range of the SLS broadcast is (and will continue to be) about 30 nmi. Semiactive BCAS is projected to have a 100 nmi sensitivity. In Figure B-16B, the message-reply sequence (left to right) indicates almost 3000 μ s of silence that typically exists between Mode A/C interrogations. This provides ample time to handle the numerous 20.3 μ s replies expected in the most densely populated airspace. Listening time is increased 100 times, since a given radar dwells for 1 percent of its rotation period on a given aircraft.

In the BCAS operation shown in Figure B-17, the knowledge of the instant an SSR main beam passes magnetic north is essential to determine differential azimuths (A) as an aid in keeping track

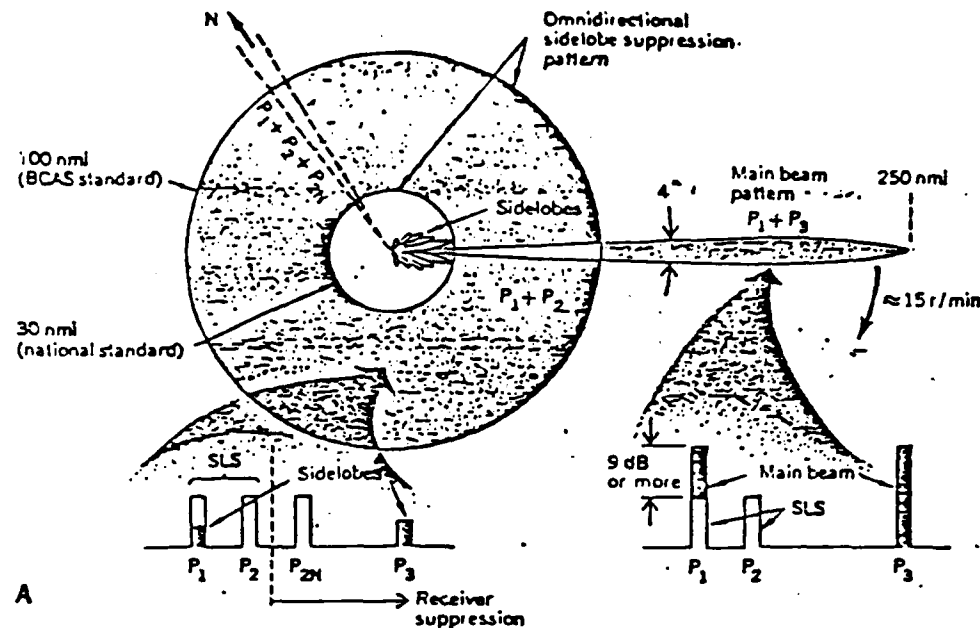

ATCRBS NETWORK

Figure B-16A

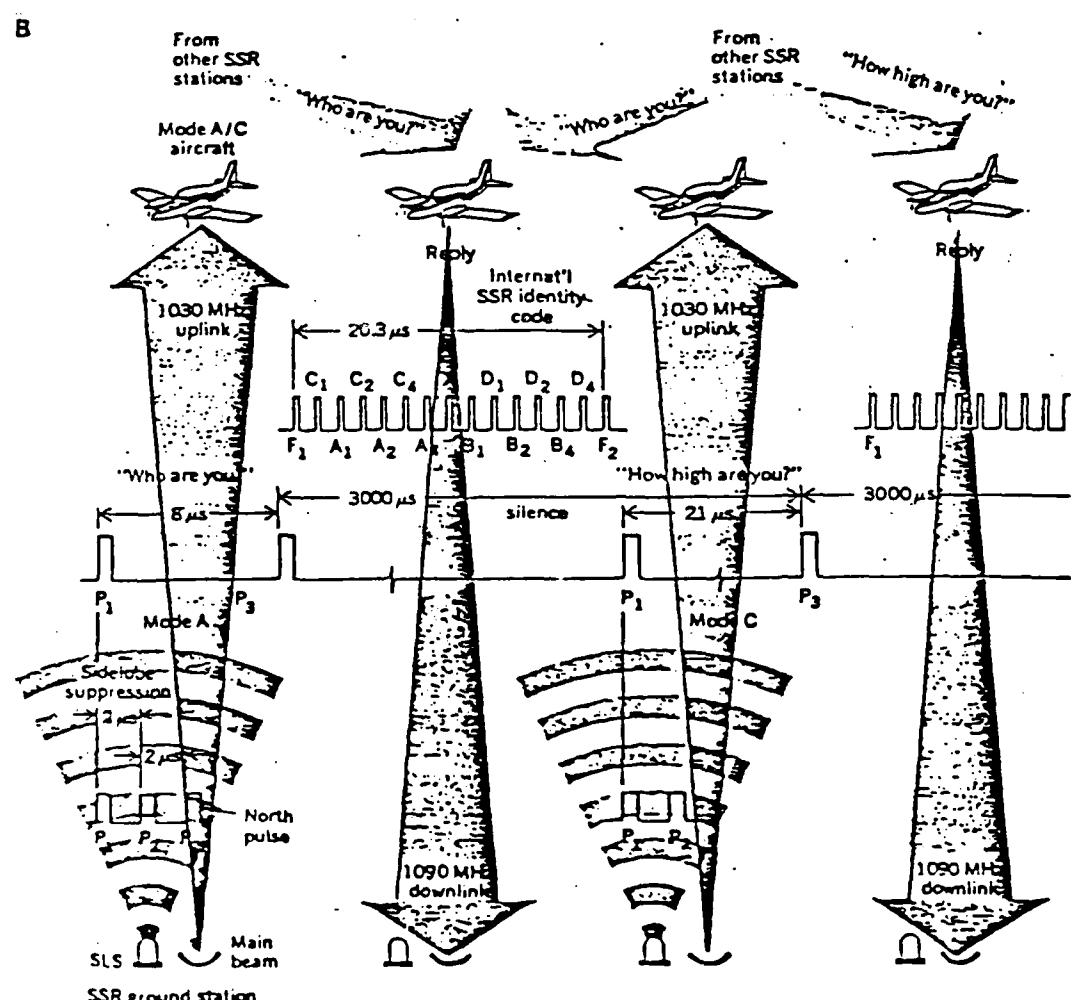

BCAS MESSAGE REPLY SEQUENCE

Figure B-16B

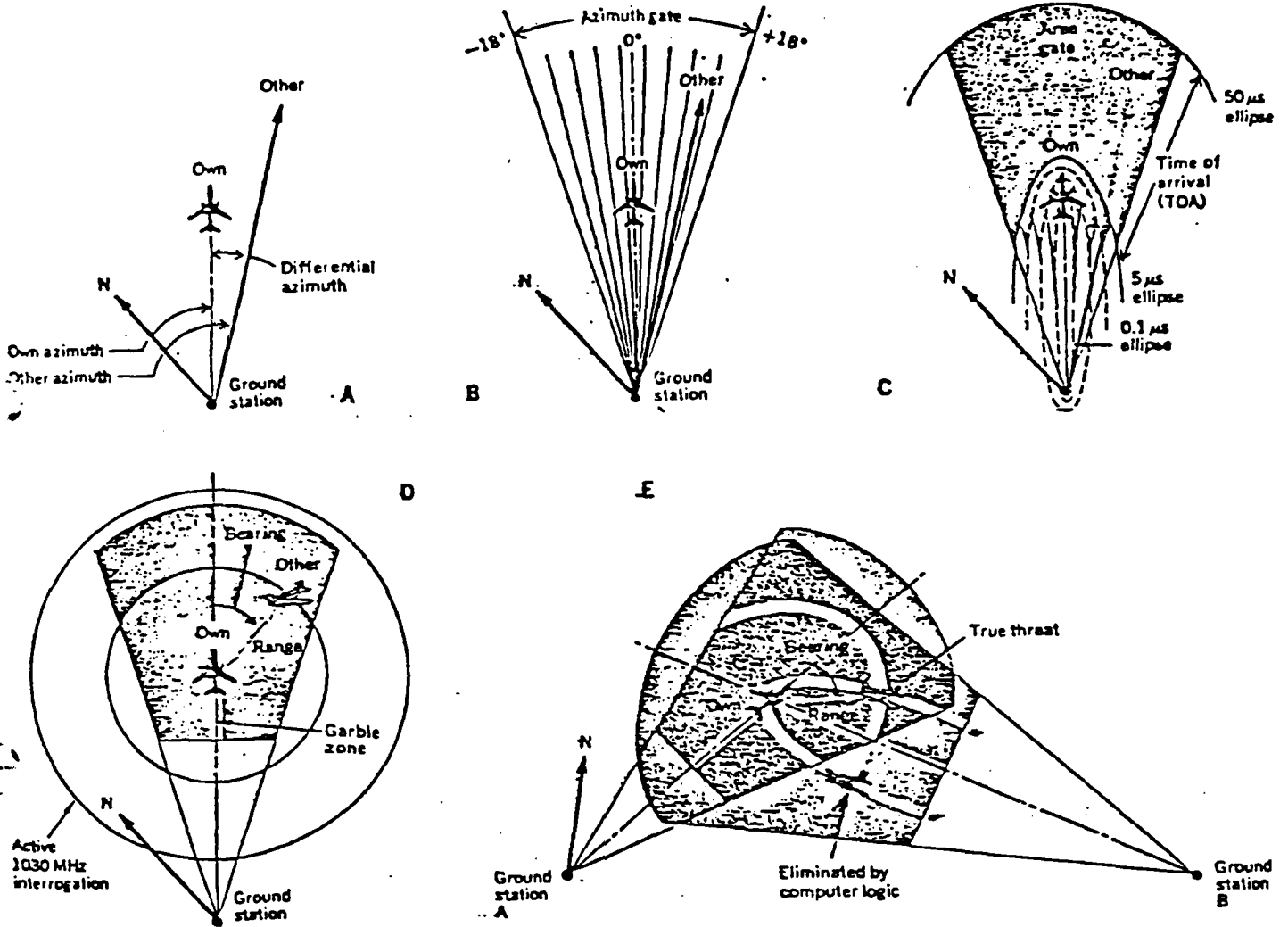

BCAS OPERATIONAL USE OF DIFFERENTIAL AZIMUTHS

Figure B-17

of a particular SSR station (by rotation period). BCAS continually accesses the potential threat once another aircraft enters the protected aircraft's predetermined area gate and altitude band. When the protected aircraft is in range of only one SSR station, it actively interrogates the identified aircraft's transponder and determines both threat range and bearing angle (D); if the aircraft is in range of two or more SSR stations (E), its range and bearing angle are easily determined passively. .
(Note: The role of the inner ellipse gate is noteworthy (C): as a potential threat enters the outer edges of the azimuth gate ($\pm 18^\circ$), an inner TOA limit of 5 μ s is considered sufficient for capture; as the threat proceeds toward 0° , however, the computer selects smaller and smaller TOAs (down to 0.1 μ s). The zone within the 0.1 - μ s ellipse is a thin area of garble. An intruder aircraft may traverse it but for a brief instant, if at all. The presence of more than one SSR station in this zone is eliminated. All drawings refrain from showing the jagged inner-ellipse boundary of (C).

F. Sierra Research Corporation CAS

Sierra Research Corporation had not developed a CAS prior to 1967 but had been developing time-frequency techniques for other airborne applications, including military station keeping devices for formation flying [2]. This concept was based on utilizing

(TACAN) channels. Range differencing was employed for estimating range rate. Compatibility with ANTC-117 threat criteria and maneuver logic was assured.

The airborne TACAN unit which interrogates TACAN ground stations operating as beacons (to measure range) can be modified to accept Sierra CAS. The TACAN ground equipment gives priority to CAS synchronization transmissions. The assignment of a channel for CAS operation preempts two TACAN channels for CAS assignment. At least two such assignments are required for a capacity to equal the capacity specified by ANTC-117; thus at least four TACAN channels would be needed exclusively for CAS.

Later, a modified system was proposed by Sierra who proposed modifying the TACAN/DME ground stations to provide synchronization and the airborne TACAN/DME equipment to provide CAS operation. In other respects it would be similar to the time-frequency technique except that range rate would be derived from successive range measurements. The range rate accuracy estimated from incremental range measurements and additional errors due to the relatively poor rise and fall times of the pulse shapes of the TACAN-DME signals which it uses are main problems with this system.

G. Miscellaneous Systems

Following is a brief description of two collision avoidance systems:

1. The Army's System [16]

The U.S. Army has been using a proximity warning device to assure separation between the aircraft. For example, at an Army facility located at Ft. Rucker where such a system has been operational, no proximity problems have been encountered for the past 15 months, according to official reports. Ft. Rucker has a fleet of 420 rotary-wing and 25 fixed-wing aircraft. The proximity warning devices were installed because proximity problems were encountered when large numbers of pilots were being trained during the Vietnam War. An antenna mounted on the aircraft radiates a signal within 500 m. Aircraft within that 500 m sphere transmit a signal that is processed to alert pilots of the presence of other aircraft. An audible warning is sounded, and an arrow lights up on the pilot's console indicating the direction of another plane. The pilot can see the other aircraft and avoid it.

2. The AeroSonic CAS [16]

AeroSonic Corporation has developed a collision-avoidance system which interrogates the transponder and altitude-reporting systems in other aircraft. There is a micro-computer aboard the aircraft to, (1) compute which aircraft are coming toward the plane, (2) calculate the rate at which they close and, (3) sound an alarm if another aircraft is within 30 seconds or 600 feet of the same altitude.

VII. FAA BEACON BASED COLLISION AVOIDANCE SYSTEM (BCAS)

FAA is developing the Beacon Collision Avoidance System (BCAS) for which national standards will be issued. The system will provide an airborne collision system [17] separation assurance and data link services among equipped aircraft. BCAS is a cooperative system capitalizing on the large investment already made by FAA in secondary surveillance radar (SSR) transponders, to achieve effective separation assurance.

The BCAS system will provide:

- o Supplemental protection to the aircraft operating inside the coverage of the ground based ATC system, where Automatic Traffic Advisory and Resolution Service (ATARS) does not operate.
- o Primary protection to aircraft outside ATC system coverage.
- o Compatibility with the primary means of aircraft separation - the ground based ATC system.

The FAA program for BCAS is divided into two BCAS systems which are under development:

- o A low development risk BCAS
 - operating in low to medium density traffic.
 - providing vertical maneuver commands to the pilot.
- o A more complex system
 - operating in high density traffic.
 - enhances the pilots ability to operate in the "see-and-avoid" environment.
 - allows horizontal maneuvers.

Based on basic requirements the BCAS must be compatible with operation of other FAA systems including ATRCBS, DABS, ATARS and the ATC system, and will function during transition from ATRCBS to DABS operation. It will also interface and coordinate with ATC and ATARS.

The BCAS must be acceptable to the pilot as well as compatible with ATC by providing safe separation while maintaining a false alarm rate which is equivalent to or lower than ATARS or Conflict Alert.

A. BCAS Technical Description

The concept on which the Beacon-based Collision Avoidance System is based is shown in Figure B-18. It is an airborne Collision Avoidance System (CAS) based on the use of replies transmitted by the Air Traffic Control Radar Beacon System (ATCRBS) transponders or the future Discrete Address Beacon System (DABS) transponder.

Two phases of development have been planned: an interim BCAS which operates actively in the ATRCBS and DABS environment, and a full system to operate actively and passively in an ATRCBS or DABS environment. The Active mode is applicable to areas where no ground beacon coverage exist, the passive mode in high density areas with ground beacon coverage. The Active mode will provide range (r),

WITHIN ATC BEACON COVERAGE

OUTSIDE BEACON COVERAGE

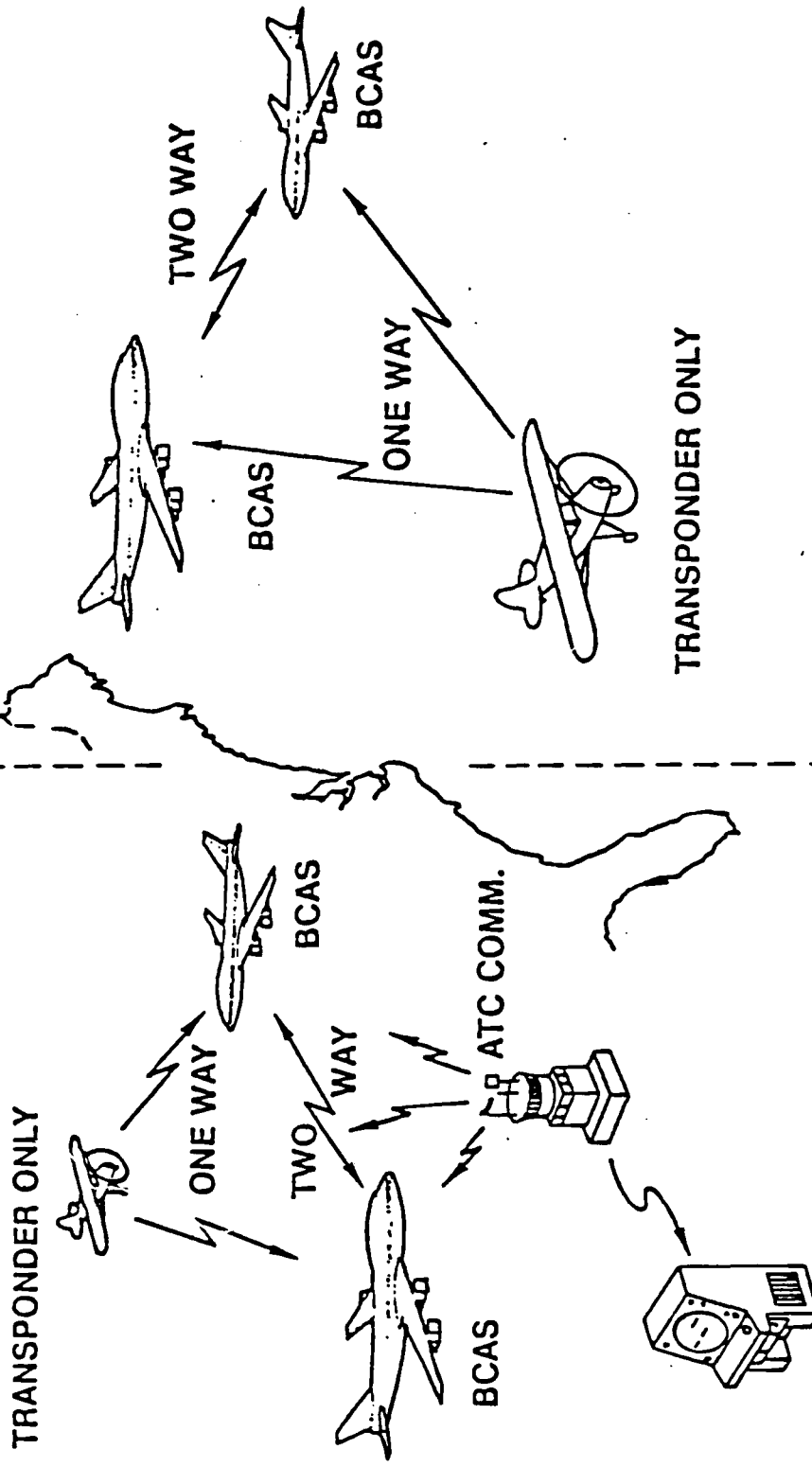

BCAS CONCEPT

Figure B-18

range rate (dR/dt) and altitude (z) information. When the system is equipped with a directional antenna, approximate relative bearing information will be provided. Thus, the Active mode can incorporate PWI capability and provide vertical escape maneuver data.

The BCAS, when in the Active mode, is an airborne interrogator, soliciting replies from other transponder equipped aircraft in communication range. The time between interrogation and reply is measured to determine aircraft range. Decoding the Mode C transponder replies leads to altitude. From this data, closing range-rate and altitude rate are determined and used to direct vertical escape maneuvers when determined by the threat evaluation logic.

B. "Whisper-Shout" Technique

Each interrogation transmitted from the omnidirectional antenna of an active BCAS, causes all ATCRBS transponder equipped aircraft in communication range to reply. An adaptation of the side lobe suppression circuitry called Wisper-Shout is used by ATCRBS interrogators to reduce the number of replies. The whisper is a low power level interrogation targeted at near and very sensitive aircraft. After replies have been received from these targets, they are suppressed. A shout is a second interrogation transmitted at a higher power level during this suppression period (nominally 35 μ sec). The system then picks up more but weakened distant targets. A Whisper-Shout procedure is repeated 5 to 7 times,

with the shout interrogation at full power so that all targets have been interrogated.

Directional antennas are also being studied to eliminate synchronous garble by directional interrogation and reception functions which limit the processing load to relatively few aircraft. The monopulse detection techniques will help to obtain relative bearing to other aircraft (theoretically to within 10 degrees) using the antenna under consideration. With this accuracy of bearings, an Active BCAS will provide Proximity Warning Information (PWI). While permitting a pilot to visually acquire other aircraft during VFR weather the PWI will in any weather provide an alert that other traffic is near.

C. "Squitter" Messages

"Squitter" messages occur spontaneously approximately once per second and make the DABS discrete address known to the BCAS interrogators, while providing coarse relative altitude information. Squitter altitude report is used by BCAS equipped aircraft to determine if the target aircraft poses a potential hazard and, if so, then uses the discrete address for the DABS interrogation. Fruit and garble are reduced since no other aircraft reply to the discrete interrogation.

D. Passive Mode

A Passive mode BCAS "listens" to ground interrogations and

airborne replies and does not contribute fruit or garble to the environment. The information which can be obtained by BCAS without any modification to the ground radar site using the BCAS phased array antenna includes: (1) the interrogation repetition frequency of the ground radar site, and (2) the bearing of the ground radar site relative to the heading of the BCAS equipped aircraft. To enable a BCAS equipped aircraft to obtain more accurate ATCRBS site information such as site altitude, more accurate relative bearing; and determine its range to the ATCRBS site, it is desirable that radar-based transponders (RBXs) be installed at the ATCRBS site. This also allows for a data link interface with ATC.

E. Semiactive BCAS

A semiactive mode of BCAS must be employed when the operation in passive mode encounters regions in which the positional errors tend to become unacceptably large due to the relative positions of the ground interrogators, the BCAS aircraft, and the target. This involves utilizing data from both the Passive and Active modes of operation, i.e., the system would collect the data actively, passively or semiactively, depending on the environment. Thus during the Semiactive mode the BCAS system obtains such data in an ATCRBS or DABS environment while it improves the total system performance as the ATCRBS undergoes a transition to DABS, resulting in lower fruit and garble levels. On detection of potential conflicts

BCAS issues the appropriate warnings based on its tracking data. When both aircraft are BCAS equipped, the maneuvers are coordinated through the use of the DABS data link issuing complementary maneuvers. If the target aircraft is not BCAS equipped, maneuvers are based on the assumption that no change in its present course will occur.

F. BCAS Display Capability

The BCAS logic is capable of driving three types of cockpit displays; the baseline Airborne Collision Avoidance System (ACAS) display, is described in Figure B-19. Another, the general purpose Plan View Display (PVD) has a pictorial plan view of intruder aircraft in the vicinity of the protected aircraft in an own-aircraft-centered and own-heading-oriented framework.

G. Phases Of Development Of FAA BCAS

The development of BCAS has been planned in the following three phases of development:

1. Phase I Feasibility Demonstration

Phase I BCAS activities were exploratory in nature and had the following chronology:

- 1968 - A PWI utilizing ATRCBS was proposed by industry.
- 1972 - USAF awarded a contract to demonstrate concept feasibility of SSR-CAS technique.
- 1973 - SSR-CAS demonstrated on ground at LaGuardia, New York Airport. FAA suggested that an active mode be added to SSR-CAS.

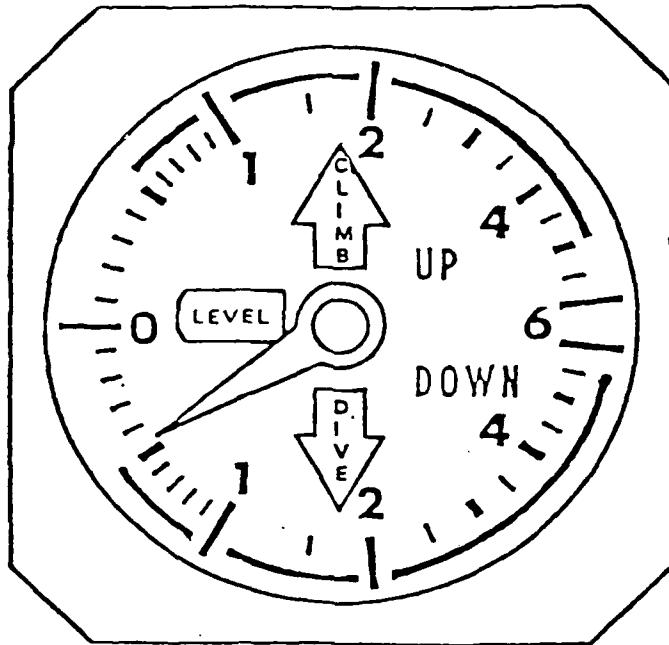

The display indicates to the pilot positive and negative commands.

Positive

Level off

Climb

Descend

Negative

Don't climb

Don't descend

Don't climb more than 500 ft/min

Don't climb more than 1,000 ft/min

Don't climb more than 2,000 ft/min

Don't descend more than 500 ft/min

Don't descend more than 1,000 ft/min

Don't descend more than 2,000 ft/min

BASELINE CAS DISPLAY

Figure B-19

1974 - SSR-CAS demonstrated on Pan Am Building, New York City. FAA conducted technical analysis SSR-CAS.

1975 - FAA proceeded to develop the Active mode portion of BCAS.

1975 - Contract awarded for delivery of an Active/Passive (SSR-CAS) BCAS system.

In Phase I an initial analysis of the BCAS operational environment (e.g., traffic models, peak densities, and ATCRBS/DABS surveillance performance) and ATC operational capability was conducted to assess the technical feasibility of the BCAS (e.g., synchronous garble, multipath, shielding, etc.).

In the second part of Phase I the design and fabrication of feasibility models of the BCAS were completed to independently demonstrate the feasibility of the Active, Passive, and Semiactive modes. The results of these investigations were promising.

2. Phase II - Engineering Development

This phase consists of upgrading the feasibility models of the Active and Passive modes fabricated under Phase I to include the functional capability deemed necessary for the operational BCAS system. In addition, it includes the fabrication of a DABS mode experimental model to assess active operation in DABS environments.

Three such engineering models of the interim active BCAS will be developed by Lincoln Laboratory. These models will help assess the DABS compatibility and operation of the BCAS system. A U.S. National Standard for Active BCAS will be based on the evaluation results.

The Phase II full BCAS Engineering Model development effort is divided into two tasks: (1) design definition, and (2) development and fabrication of three BCAS engineering models. In this development phase preliminary analytical efforts will be included to examine operation of BCAS in the ATC environment, compatibility with the ATC system and acceptability to the pilot. Such studies include:

- o ATC System Compatibility Assurance

ATC system compatibility assurance manifested in terminal areas where controllers intentionally bring aircraft into close proximity to maximize terminal operations. It is primarily a function of the BCAS threat evaluation and maneuver selection logic. If the alarm rate is allowed to be too high, it will result in many and unnecessary maneuvers. Hence the system will be unacceptable to the controllers, pilots and passengers. However, the trade-off involved in reducing the alarm rate is reducing the protection provided.

- o Determination of ATC Interference

The fruit and garble generated within the ATC system by BCAS causes interference which is also a function of the BCAS modes of operation--including wisper-shout. A computerized simulation model was constructed which simulates interrogations generated by aircraft equipped with BCAS and merges these signals with those generated by the ground system in a DABS/ATCRBS

o Performance Prediction Model (PPM)

Based on PPM, computer study predictions were made to evaluate the effects of BCAS electromagnetic emissions on ATCRBS ground interrogators in a standard traffic environment. Predictions were also made for fruit-rates at an airborne interrogator and the effects of the variations in the use of whisper-shout in a given standard environment. It was determined that in the test environment:

- deploying active BCAS will result in a slight reduction in aircraft reply probability, but will not impact the ATCRBS ground receiver/processor performance.
- instantaneous fruit-rates at an airborne BCAS of up to 14,000/sec could be expected at 20,000 feet. DABS power programming had no effect on BCAS-generated interference.

o BCAS Operation in Synchronous Garble and Fruit

BCAS operation in synchronous garble and fruit is a function of the spacial density of aircraft and the number of ground interrogation sites, it is more of a problem in the active mode (passive mode adversely affected in the higher density terminal areas only). Garble is the interference experienced by a reply signal when overlapped by another reply. It can alter the altitude code between the framing pulses (f_1 and f_2) of a reply signal by the addition or destruction of bits, or can cause the loss of a reply signal altogether by interfering with the detection of its framing pulses. Studies of fruit and garble rates were carried out in a standard target airspace environment where BCAS will be deployed.

In the active mode of BCAS, garble or overlapping reply messages result when the aircraft, in the vicinity of the threatened equipped aircraft, reply to ground radar interrogations and to interrogations from other equipped aircraft. It is also generated by the interrogations transmitted by the threatened equipped aircraft so that other aircraft replying to these interrogations are close enough together causing their reply messages to overlap.

Synchronous garble in passive BCAS is due to aircraft within the main beam of the same SSR as the target intruder while replying to the same interrogations. The total number of recorded replies (no interrogations) in a 10 second period, divided by the total of the listening window times over that 10 second period, is known as Average Fruit Rate.

o An Evaluation Of Existing ATC Environment

This entails a thorough evaluation of the existing ATC environment for defining the necessary BCAS performance. Extensive testing of the occurrence of terrain induced multi-path on air-to-air links, resulted in serious findings of existence of multi-path echoes and multi-path scatter from smooth surfaces and water. Top-mounted antenna were found suitable for prevention of multi-path. The BCAS transmitter power and receiver minimum-triggering-lever (MTL) values were established to match desirable link reliability.

o BCAS Performance Evaluation

A variety of factors, ranging from fruit and garble to the algorithms selected, influence the ability of BCAS to function in any given environment. Simulations on computers being made of BCAS in varying levels of traffic density will lead to anticipated results. The accuracy of BCAS measurements was assessed by measurement of factors (e.g., Time-Of-Arrival (TOA), Differential Azimuth (DAZ), and Own Azimuth (OAZ)) and comparison of these with theoretically predicted values based on the geometric relationship of the radar, target transponder (determined by survey) and BCAS position (measured by the EAIR radar). The measured values of TOA, DAZ, and OAZ were also used to compute the range and bearing to the target.

Mathematical algorithms have been developed as a result of a thorough analysis to compute the range and bearing to potential threat aircraft and to ground radars, using passive-mode BCAS measurements. A computer simulation was conducted for the following three different modes of purely passive operations:

- all radars equipped with azimuth reference signals

-- none so equipped

-- only one radar so equipped available at a time.

The results confirmed that either system--assuming all radars equipped with azimuth reference signals or only one radar within BCAS range so equipped-- is technically feasible. Test and evaluation of the feasibility equipment for the active ATRBS mode of BCAS was performed in a NAFEC airborne test bed based on sending out omnidirectionally a mode C (altitude) interrogation on a one-second cycle, reception and processing of all returns, delivery of target information to a threat evaluator, and providing resolution maneuvers on an indicator. The object was to shed light on the ability of the equipment to detect, sort out, and track the many overlapping replies that arrive in response to a single omnidirectional interrogation. It was found that aircraft antenna shielding or multipath, was the major factor affecting the overall tracking performance, and the synchronous garble or tracker parameters had far less to do with degradation.

3. Phase III - Prototype Development And Operational Tests

During this phase the operational suitability of the BCAS will be verified around which national standards may be written. Field tests will be conducted to confirm the utility of the BCAS operation, to determine the phenomena that limit performance, and determine the related environment. These tests will involve installation of BCAS prototype on GA, military and air carrier aircraft for its evaluation in the operational environment.

H. The National BCAS Standard

The Active-Mode version of BCAS which has been recently

approved by FAA and for which a National Standard is being issued is a ground-independent air-to-air system. It is activated by airborne omni-directional ATCRBS Mode C interrogations occurring at a rate of 2 per second. Range and altitude rates are computed, and approaching aircraft are tracked. The cockpit CAS display warns the pilot of aircraft crossing with adequate altitude separation and gives a command to climb or dive if the intruding aircraft is at or near the same altitude. Warnings and/or commands are provided 30 seconds before range minimum.

It is designed for aircraft who wish to have a CAS capability in airspace where the air traffic control (ATC) system does not provide surveillance-based separation services. In addition, the system will provide some backup to the ground system in airspace within surveillance coverage.

The system thus assumes widespread deployment of altitude-reporting ATCRBS, which the BCAS-equipped aircraft can sense and avoid. The ATCRBS-only aircraft (called a remitter), which does not have the BCAS equipment, would not receive collision avoidance warnings; it is assumed that this aircraft continues on its present course. BCAS also provides protection for two BCAS-equipped aircraft, ensuring complementary maneuvers.

The attractiveness of BCAS is that its cost is only to the

equipped user desiring an independent collision avoidance capability, which protects it from all aircraft which are transponder-equipped with Mode C (altitude reporting) capability. However, the co-sharing of the channel with ATCRBS imposes two requirements on the design which had to be met if this concept was to be feasible.

BCAS should not significantly impact the ATCRBS performance, and would have to work in spite of garble. The design calls for a rate, achieved by limiting the rate of interrogations, of only two interrogations persecond. Preliminary analysis of flight data indicated the system is capable of tracking successfully through garbled situations where as many as five overlapped replies occurred.

The BCAS functional block diagram is given in Figure B-20. Mode C interrogations are transmitted sequentially via top and bottom antennas, and received replies are demodulated in the receiver and then passed to the detector/tracker. The detector/tracker determines if the received replies are from new targets, established target tracks, or simply fruit. Tracks are formed and maintained in range and altitude. An altitude reference is provided by the aircraft's own encoding altimeter, which enables the tracker to estimate the relative altitude of targets.

Newly formed tracks within a 10-nmi range and established

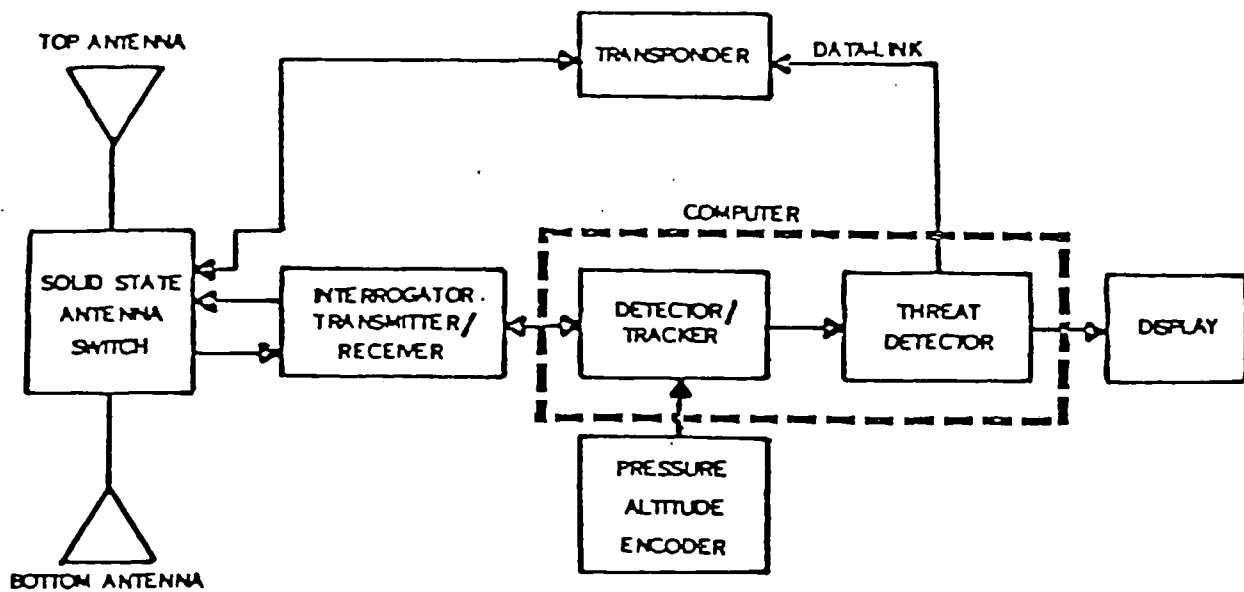

ACTIVE MODE BCAS SYSTEM BLOCK DIAGRAM

Figure B-20

tracks whose range difference becomes 10-nmi or less are flagged by the tracker and a determination of whether this target is BCAS equipped or not is made. To make this determination, a Mode D interrogation is sent. If the target replies (and it appears at the expected range and altitude), the tracker labels the target as BCAS equipped; otherwise, it is labeled as unequipped, since all equipped aircraft have a Mode D reply capability. Established tracks (tracks are declared established after being tracked for at least 30 seconds or after 4 successive ungarbled reports) are passed on to the threat detector to determine if a target is a threat. Separate algorithms are used for equipped and unequipped targets. When an unequipped target is determined to be a threat, a command is displayed to the pilot for him to maneuver his aircraft away from danger. If, on the other hand, an equipped target is determined to be a threat, a Mode D interrogation is made to the target to assess the maneuver intent of the target. On the basis of the reply received, a command is displayed to the pilot, which makes him aware of the situation and which may direct him to either maneuver or not to maneuver his aircraft. When interrogated on Mode D, the aircraft replies with a code that describes the command message sent to the display. This elementary data link provides the means for ensuring that the aircraft made complementary maneuvers.

I. The Modes Of BCAS Operation With ATCRBS And DABS

1. BCAS/ATCRBS Mode

In the BCAS/ATCRBS mode, [18] BCAS interrogates on Mode C (altitude) using both the top and bottom-mounted antennas (Figure B-21). At altitudes above 10,000 feet, 500 watts is transmitted from the top antenna and 125 watts from the bottom antenna, (less the transmission line losses). When the aircraft is flying below 10,000 feet the transmitted signal's power is reduced by 6 dB.

The ATCRBS mode interrogation procedure is a function of the garble (overlapping reply level) at the BCAS receiver. A low-density interrogation procedure is employed when the number of detected overlapping replies is less than four, otherwise a high-density interrogation procedure is employed.

| | <u>Low-Density Procedure</u> | <u>High-Density Procedure</u> |
|---|---|---|
| Number of overlapping replies received: | Less than Four | Whisper-Shout Four or More |
| Interrogation procedure: | A full-power mode C from the top antenna. | Whisper-Shout Subdivides the air traffic population into smaller groups. |

o Low Density Interrogation Procedure

Approximately 350 μ s subsequent to initial interrogation, after receiving replies, a P₁-P₂ suppression pulse pair is transmitted from the top antenna at the same power as the interrogation. Those transponders

LOW-DENSITY ENVIRONMENT

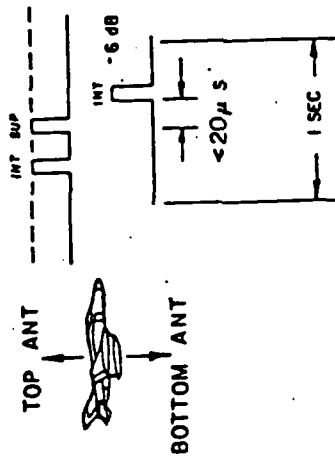

HIGH-DENSITY ENVIRONMENT
(4 OVERLAPS)

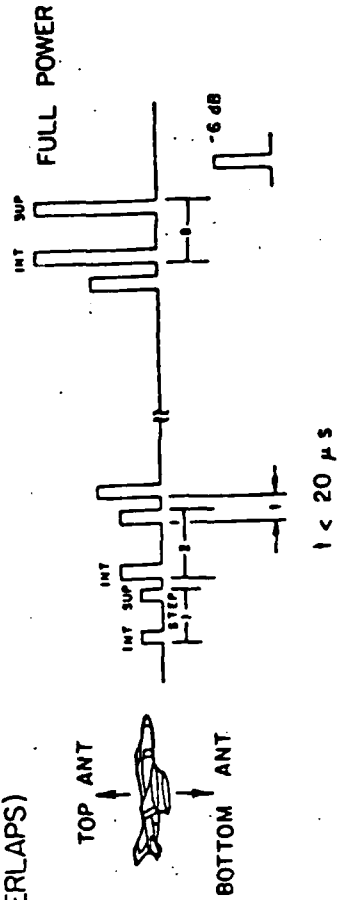

8 STEPS / TOP ANT } 1 SEC
1 / BOTTOM ANT }

BCAS/ATCRBS MODE [18]

Figure B-21

that received the interrogation from the top antenna will be suppressed by this procedure. While they are still suppressed (approximately 20 s after transmission of the (P₁-P₂) suppression), a Mode C interrogation is transmitted from the bottom antenna. This procedure is repeated once per second.

o High Density Interrogation Procedure

In a high density atmosphere, a series of eight interrogations/suppressions is transmitted from the top antenna at the relative power levels shown in the table below. The maximum transmitter output peak power is assumed to be 500 watts; same as that for the ATCRBS transponder. Advantage is taken of the variation in transponder sensitivity, aircraft antenna pattern and range to subdivide the aircraft population into smaller groups, by suppressing all aircraft previously interrogated before transmitting the next interrogation. The subdivision of the aircraft population reduces the number of overlapping replies to a level that the BCAS computer can handle. The successive interrogations are spaced approximately 350 micro-seconds apart. Prior to each interrogation, except the first, a (P₁-P₂) suppression pulse pair is transmitted at the power of the previous interrogation, which is repeated once per second.

BCAS RELATIVE POWER LEVELS
(ATCRBS MODE STEPS AND DABS MODE POWER PROGRAMMING)

| Step | Power Relative to Maximum ^a (dB) |
|------|---|
| 1 | -19 |
| 2 | -16 |
| 3 | -14 |
| 4 | -12 |
| 5 | -10 |
| 6 | - 8 |
| 7 | - 4 |
| 8 | 0 (maximum) |

^a 500 Watts

- o ATCRBS Synchronous Interference Elimination

Jitter Mode is utilized to prevent synchronous interference. For this purpose the BCAS spaces ATCRBS interrogation trials at $(1 + k)$ second intervals, where k is a random number between $+0.1$ and -0.1 .

2. BCAS/DABS Mode

The BCAS interrogator listens for DABS aircraft transmissions (squitter) (Figure B-22), and interrogates individual aircraft using the DABS aircraft discrete address. Active interrogations are made during initial range acquisition, tracking outside the horizontal alarm volume, and tracking inside the horizontal alarm volume.

- o Alarm Volume

The alarm volumes associated with the DABS mode are:

- the vertical alarm volume, (the airspace 2000 feet above and below the BCAS aircraft); and

- the horizontal alarm volume, the airspace within a variable distance of 1 to 11 nmi (a function of closure rate computed as 1 nmi plus the closure rate in nmi/sec times 30 seconds).

- o Squitter Acquisition

In the active BCAS System each DABS transponder-equipped aircraft transmits a squittered reply containing altitude and address information (once per second) from which BCAS receivers compute altitude separation and altitude closure rate between their own aircraft and the intruder. When these computations indicate that the intruder will penetrate the vertical alarm volume, BCAS directs addressed interrogations to the intruder aircraft.

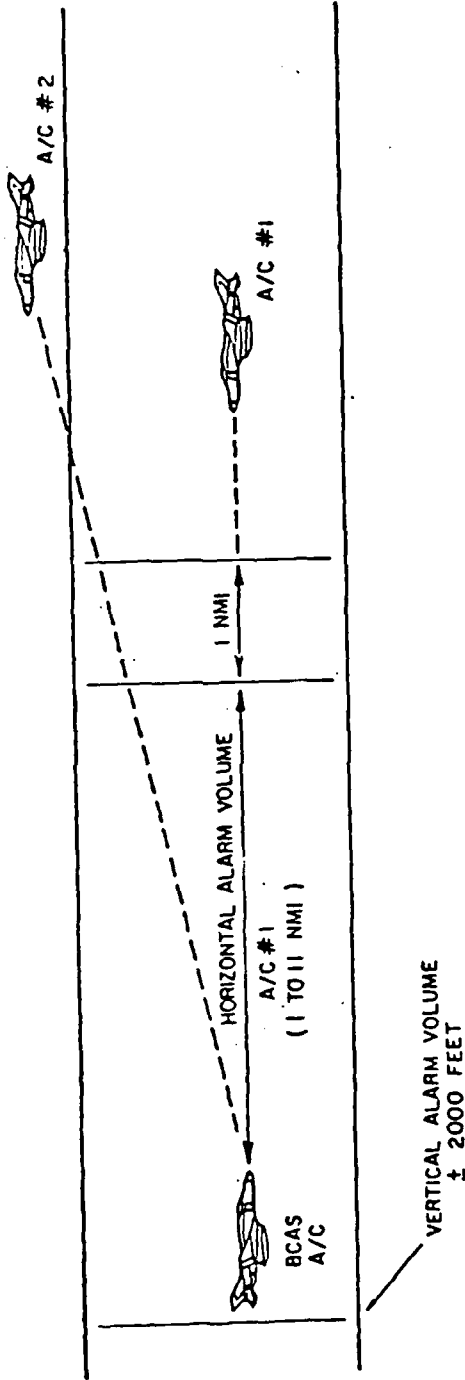

1. Listens to squitter to track vertical separation.
2. Initial range acquisition (ACTIVE) 4 seconds prior to entering vertical alarm volume.
3. Active interrogation outside horizontal alarm volume.
4. Active power programming inside horizontal alarm volume.

BCAS/DABS MODE [18]

Figure B-22

The top antenna is used for these interrogations if the intruder aircraft is above the BCAS aircraft, otherwise the bottom antenna is used.

o Acquisition Of Initial Range And Range Rate

Two to eight interrogations (at a maximum power of 500 watts) are sent depending on the reply overlaps and missing replies. This is used by the BCAS computer to determine if the intruding aircraft has entered or will enter the horizontal alarm volume. If no replies are received the procedure will be repeated at 10-second intervals as long as the aircraft remains in the vertical alarm volume.

o Tracking Outside Horizontal Alarm Volume

As long as an intruder aircraft flies outside the horizontal alarm volume, but within the vertical volume, it will be tracked by discretely addressed active BCAS interrogations. Based on a maximum closure speed of 1000 knots, the BCAS computer calculates the point in time at which the intruder aircraft could reach the horizontal alarm volume plus 1 nm, and active interrogations are sent out to update the track. No less than 1 second and no more than 10 seconds are allowed between updating of the tracks. Up to eight interrogations per update interval are transmitted until two successful interrogations are completed.

o Tracking Inside Horizontal Alarm Volume

To allow for decreasing range, less power is transmitted for interrogation when an aircraft enters the horizontal alarm volume. Eight power levels (the same relative levels as employed for the ATCRBS Mode) are used. During the first 5 seconds of tracking in the horizontal alarm volume, DABS interrogations are transmitted at full power (500 watts). After every three successful interrogations the power level is reduced by 1 step, and maintained for 5 seconds. To reach the lowest usable power, this process is continued. When three successive failures occur the power may be raised a step.

o DABS BCAS Mode Interrogation Rates

The rate at which BCAS interrogates DABS aircraft is a function of the number of missing and overlapping replies.

VIII. AUTOMATIC TRAFFIC ADVISORY AND RESOLUTION SERVICE (ATARS)

ATARS is a key element [19] of the FAA's Aircraft Separation Assurance Program (ASAP) of the future. It is a pilot oriented ground-based collision avoidance system based upon the earlier concept of Intermittent Positive Control (IPC) which was described and recommended for development by the Air Traffic Control Advisory Committee (ATCAC) in 1969. Using the surveillance data obtained from the Discrete Address Beacon System (DABS), it computes traffic and resolution advisories "as needed" (on-ground computer system), and delivers these advisories to ATARS equipped aircraft via the DABS data-link.

An introductory overview of the development of the IPC concept which was later renamed ATARS follows.

A. Intermittent Positive Control

IPC is an experimental ground-based Collision Avoidance System. [20] It is being designed to assist aircraft in avoiding hazardous air traffic situations. When required, it will separate VFR aircraft from one another via ground-computer-derived advisories or commands forwarded to cockpit displays without controller intervention. It will also help separate VFR aircraft from IFR aircraft without controller intervention. However, the IFR aircraft will have an additional advantage of being under control of the ATC system. For two conflicting IFR aircraft, IPC

is intended to serve as a backup to the conflict alert (CA) function of the NAS En route system. The conflict alert function provides flashing data blocks of conflicting IFR aircraft to the controller on the plan view display (PVD). The cockpit displays are designed to show the relative azimuth and altitude of an intruder aircraft and, in addition, give command or maneuver instructions to the pilot. Some types of display are shown in Figure B-23.

The Discrete Address Beacon System (DABS) is a cornerstone of the Collision Avoidance System. DABS provides a data link capability between an aircraft equipped with beacon/IPC-ATARS equipment, and the air route traffic control center (ARTCC) in the sector where it is flying. The IPC-ATARS monitors the location, altitude, and velocity of these beacon-equipped aircraft. (Figure B-24).

The data is transmitted over the DABS link to the ground, where a computer processes it, while projecting three dimensional flight paths. The computer also provides proximity warning indicator (PWI) information to aircraft equipped with the IPC-ATARS cockpit display, as well as warning the controlling air traffic controller. Collision resolution commands indicating evasive maneuvers are also calculated by the computer and displayed on the aircraft's cockpit appropriate display.

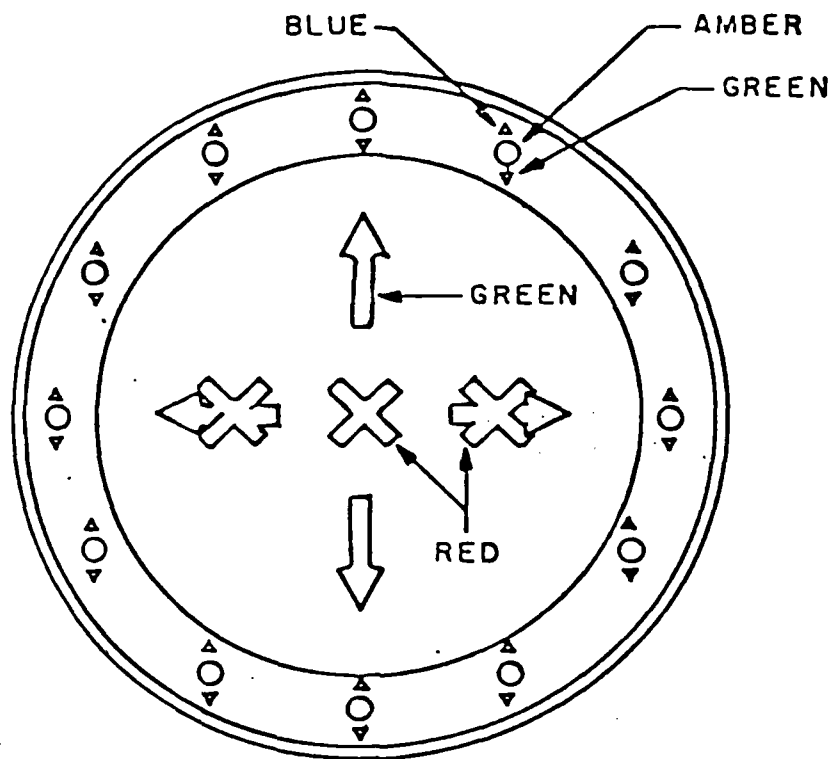

(i) BADCOM DISPLAY

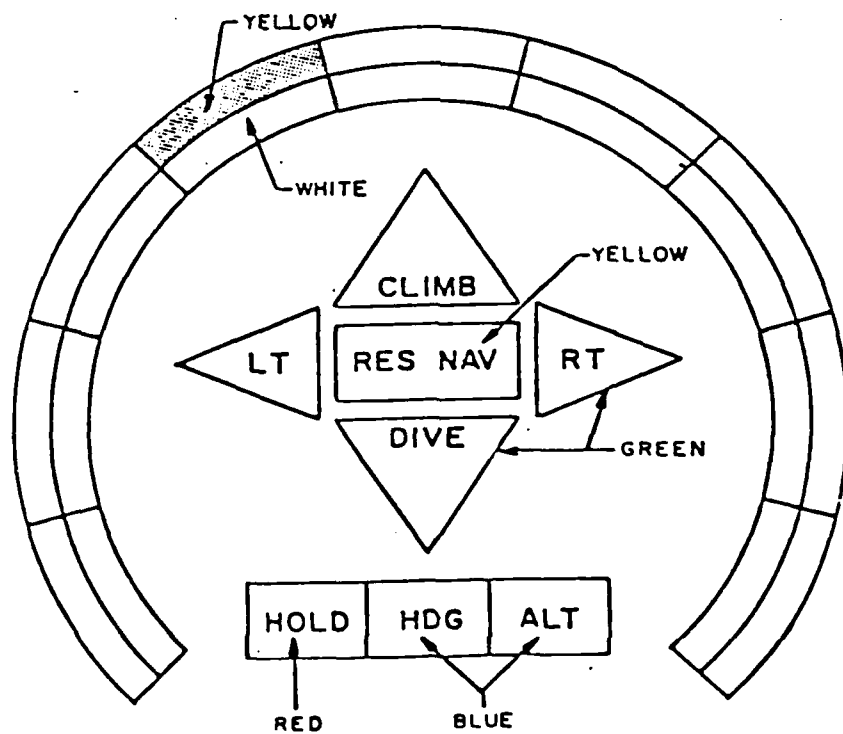

(ii) NAFEC-PROPOSED DISPLAY

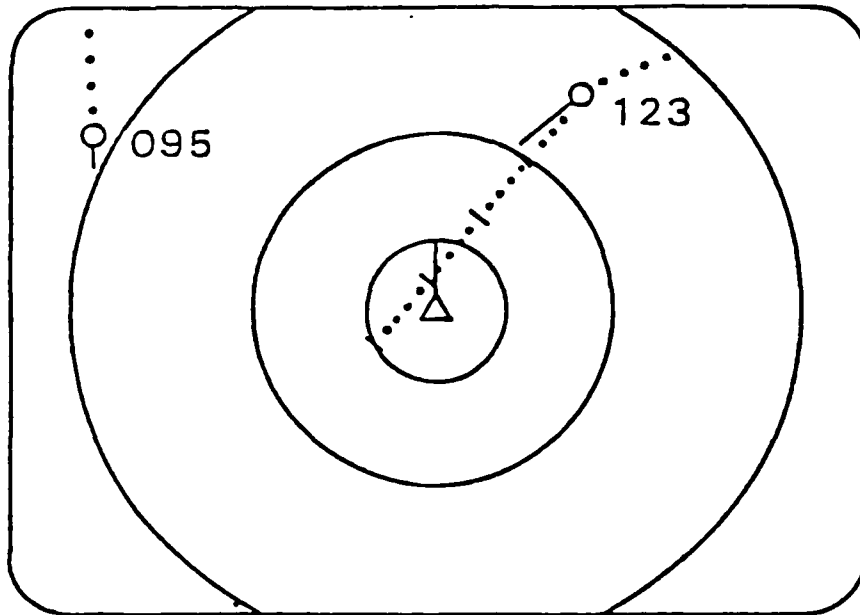

(iii)

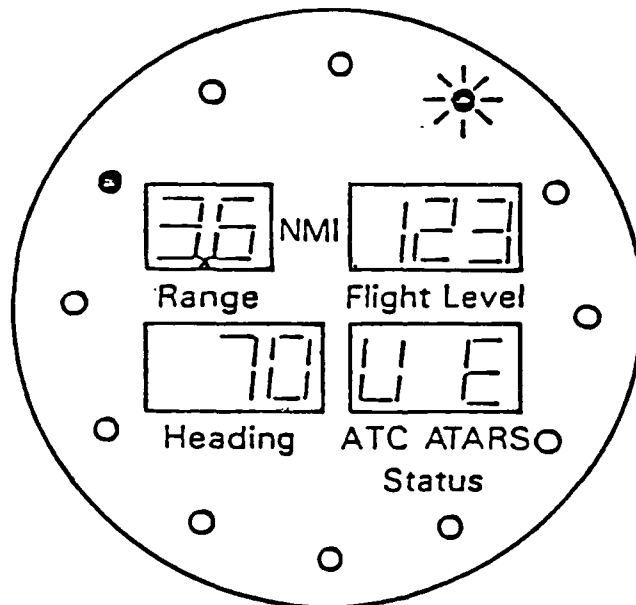

(iv)

ALTERNATIVE IPC DISPLAYS

Figure B-23 (Continued)

DABS/ATARS Concept

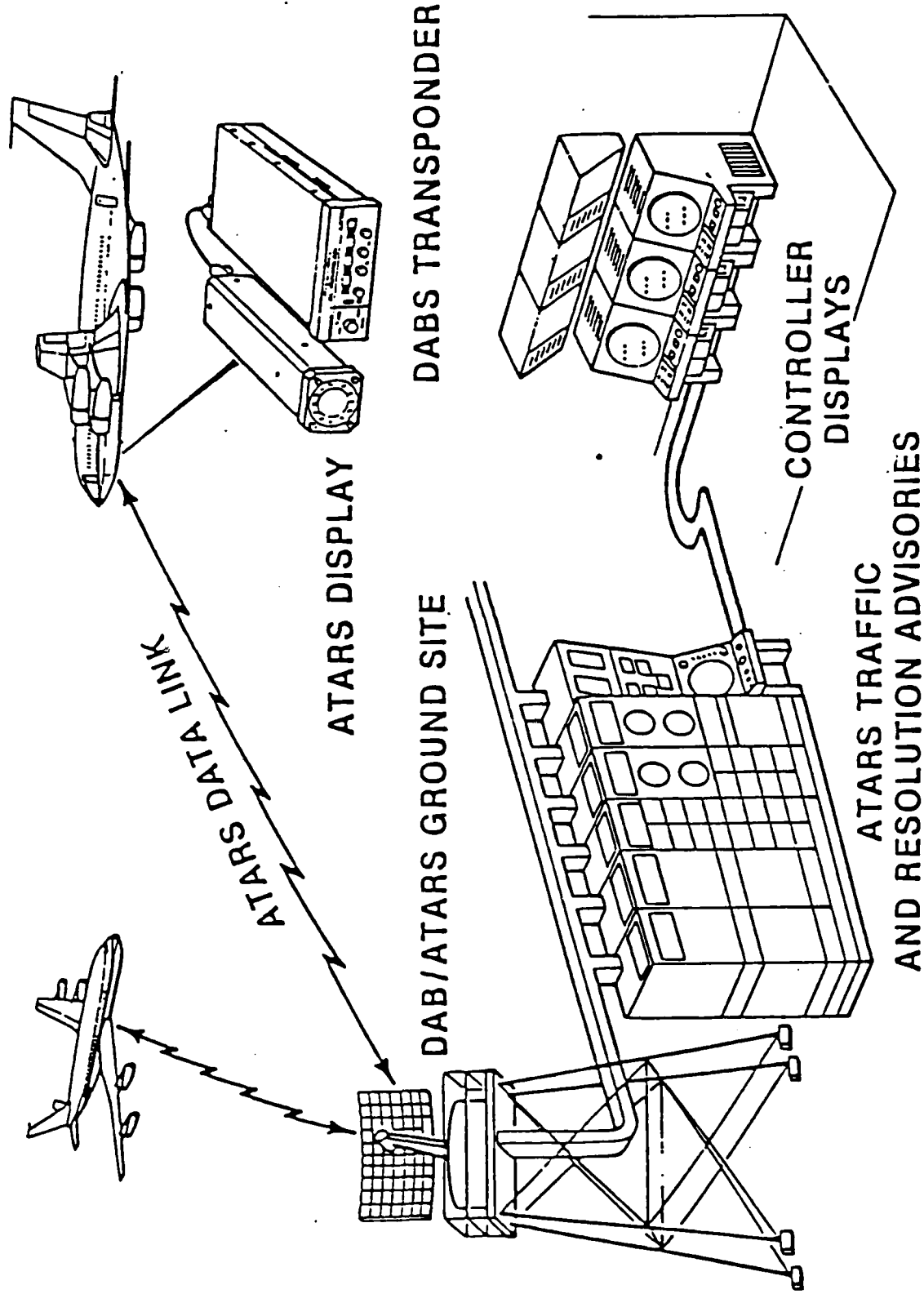

Figure B-24

Further Displays are provided at the air traffic controller's position to indicate the responses of the threatened aircraft to whom the evasive maneuvers have been transmitted. Such indicators show whether the pilot is complying with commands. Moreover, if the system is not in position to transmit to aircraft ("U" means unable to transmit message), another instruction "V" is issued to the controller indicating a verbal contact is warranted.

The pilots of IPC-ATARS equipped aircraft receive a comprehensive traffic advisory service and an effective resolution service. IPC-ATARS services are designed for all aircraft, controlled and uncontrolled, in both the en route and terminal environment, for protection against all aircraft that are equipped with altitude reporting transponders (presently 100% of the air carrier and military fleets and 17% of the general aviation which is supposed to increase substantially in the future.

Only the aircraft carrying a DABS transponder and an ATARS display on-board may receive the IPC-ATARS service. The DABS transponder has altitude coding capability, besides its beacon function also receives coded messages from the ground for delivery to the cockpit IPC-ATARS display.

At the ground level IPC-ATARS includes a DABS sensor to receive surveillance information, and to communicate with the

aircraft. It also includes a computer which interfaces with ATC facilities.

Traffic advisories are sent to the IPC-ATARS equipped aircraft, as computed by the ground computer using a standard algorithm, when other potentially threatening aircraft are detected. For a proximate aircraft, the pilot will be alerted to its presence to aid him in visual acquisition. This enables the pilot in avoiding maneuvers which may aggravate the situation. When the projected miss distance is sensed by the ground computer to be less than the defined threshold a resolution advisory is sent to the aircraft.

The pilot of the uncontrolled aircraft relies on see-and-avoid techniques as the principal method of maintaining separation, he utilizes the traffic advisories to visually acquire proximate aircraft and to determine whether or not they represent a potential threat. Once the aircraft is visually acquired, the pilot mentally integrates the traffic advisory data with other factors to determine what evasive action need be taken.

To minimize pilot work load and ATC interaction, controlled aircraft will rely on resolution advisories for determining the maneuver needed to resolve potential conflicts. The pilots independent maneuvers are discouraged, (which could aggravate the

situation) by alerting him to the specifics of the potential conflict. When IPC-ATARS issues a threat advisory or a resolution advisory, the ATC facility responsible for the aircraft is simultaneously notified.

Lincoln Labs of MIT are expected to complete the traffic advisory services and the microprocessor based display, ready for flight testing at NAFEC with DABSEM in the Fall of 1979. A software package has been developed by MITRE/MITREK which will utilize the ARTS III traffic data tapes for preparing a test population as an aid to improvement, refining and validation of a reliable algorithm for IPC-ARTS. This algorithm is tested by subjecting it to extensive fast-time and real-time simulation prior to a series of extensive flight tests.

B. Traffic Advisory Service Development

The Traffic Advisory Service component of this system is primarily meant to alert the pilots of the VFR community. The assistance provided to the pilot through Traffic Advisory Service is defined by the following FAA objectives:

- o Providing help in visual acquisition of aircraft which are or will be close enough to be of concern.
- o Evaluating whether or not an aircraft represents a threat.
- o Selecting a safe and effective escape maneuver.
- o Maintaining separation in the absence of visual acquisition.

There are two principal benefits of a traffic advisory service designed to meet the above objectives, namely:

- o Prevention of mid-air collisions involving VFR aircraft without restricting freedom of flight.
- o Reduction of the probability of an aircraft maneuvering in a direction that would aggravate the potential conflict (complementary to the resolution service).

Aircraft are considered to be in potential conflict when the following parameters are satisfied:

- o The estimated time to closest approach is less than 45 seconds, and
- o The estimated horizontal miss distance is less than 1 nmi or the estimated vertical separation at closest approach is less than 1,000 feet.

C. Resolution Service Development

Resolution service development is designed for compatibility with the traffic advisory service, this component of BCAS is foreseen to be relied upon by pilots of controlled aircraft.

The performance objectives have been defined as:

- o Safety and reliability.
- o No disruption of routine ATC service, e.g., advisories shall not cause the aircraft to depart from instructed or mandatory clearances.
- o Ability to dispense guidance for prevention and/or resolution of conflicts in most regions of airspace.

- o Compatibility with ATC procedures.

The IPC resolution algorithm has been designed and modified based on extensive flight tests, ATC simulation, Monte-Carlo simulation of 12 mid-air and analysis of ARTS III data for ATC interaction. The results of the effort points to the need for further modifications in the following areas:

- o Reduction of ATARS interaction with ATC system (site adaption logic for the terminal area, utilizing uniform logic for both VFR and IFR aircraft and optimizing alarm threshold).
- o Perfection of exhaustive search technique to replace initial fixed rule approach. (Flying aircraft pair ahead in fast time for each set of candidate single-plane and multiple-plane maneuvers, for the purpose of computing statistics such as achievable miss distance. The candidate maneuver sets are then rank ordered considering technical factors such as miss distance and user oriented criteria).
- o Development of turn sensing logic for more responsive maneuvers particularly in the terminal area.
- o Development of a domino logic (to minimize the probability of resolution advisories causing chain reactions).
- o Development of a multi-aircraft logic (for situations when chain reactions would be unavoidable with two aircraft logic).
- o Development of a logic for vertical speed limits and horizontal turn limits.

D. Flight Test Results On IPC Algorithm

The IPC algorithm is the base of ATARS, and Lincoln Laboratories of MIT conducted extensive flight tests to analyze its

performance, and the manner in which pilots used the service. From the Fall of 1974 until early 1977, some 130 demonstration and test flight missions were flown for this purpose. While these tests established the feasibility of the ATARS concept, they also brought to light some deficiencies of the existing algorithm.

Although the system tested indicated that its resolution or command service was consistently effective in nominal encounters, it produced unnecessary, late, or improper commands in situations involving non-nominal (accelerating, etc.) conflicts. These may be contributed to insufficient resolution, including factors e.g.:

- o Uninvolved aircraft close to an ongoing conflict can become involved if they are not properly considered initially.
- o Non-uniform logic can allow conflicts to be prolonged or worsened by delaying commands to an IFR aircraft in conflict with a VFR aircraft.
- o No input to command selection logic was provided for turn sensing or rate of turn.
- o Commands selected by the system followed fixed rules based on the conflict geometry. This aspect of command selection in accelerating conflicts led to the choice of improper commands due to the changing conflict geometry.

The initial IPC algorithm and concept is undergoing modification as a result of the conclusions derived from the extensive flight testing. There are many questions for which answers are sought from such tests, e.g.:

- o What basic information must be provided to the pilot to accomplish the stated objectives?
- o What precision is required in the information provided?
- o What combinations of data and display techniques should be considered?
- o What criteria should be used for displaying a traffic advisory?
- o How will the urgency of the situation be conveyed to the pilot?
- o How will multiple advisories be handled?
- o What is the concept for providing the advisory data via the DABS data-link?
- o Does the traffic advisory service have any impact on the ATC system or procedures?
- o How will the traffic advisory service be compatible with and compliment the resolution service?

E. The FAA Technical Approach

The design of both the traffic and resolution advisory systems is being pursued in parallel, while efforts are being made for mutual operational compatibility.

Modification of ATARS logic is foreseen to expand its capability in areas e.g., terrain avoidance and restricted airspace avoidance (for keeping uncontrolled aircraft outside of Terminal/Positive Control Areas). Following the full development, multi-site ATARS logic will be subjected to rigorous performance and compatibility testing in the ATC environment using the three DABS sensors.

A micro-processor based display is being developed to provide the pilot (for example) with bearing information symbolically (clock lights), and headings, range, altitude and aircraft status shown in alphanumeric. A candidate CRT air carrier display is known as "Relative Motion Display" and indicates all nearby aircraft by vector symbols with alphanumeric tags. A center display symbol represents the subject aircraft.

ATARS development is anticipated to lead to a prototype, capable of providing effective service in the en route and terminal airspace as well as in the single multi-sensor environment.

IX. CAS MILESTONES

Figures B-25, B-26, B-27 and B-28 are included to indicate the scheduled events in the design and deployment of BCAS (active-only and full capability types) as well as ATARS and DABS programs.

X. CONCLUSION

Safe utilization of national airspace is a prime concern of the FAA, which over the past decade or so led to a search for a means of assuring collision free aviation. The need for a dependable and economical system has become evident in light of growing air traffic, and associated statistics of mid-air and near-miss incidents.

BCAS PROGRAM AND DEVELOPMENT DEADLINES

- o ACTIVE-ONLY NEAR TERM
 - Draft National Standard December 1978
 - Flight Tests Complete March 1980

- o FULL CAPABILITY
 - Design Concept Completed April 1978
 - Industry RFP December 1978
 - Competitive Design Studies
 - Engineering Models for Flight Test
 - Prototyping for Operational Tests by Users (if needed)
 - National Standard October 1983

FIGURE B-25

1990 BCAS REQUIREMENTS

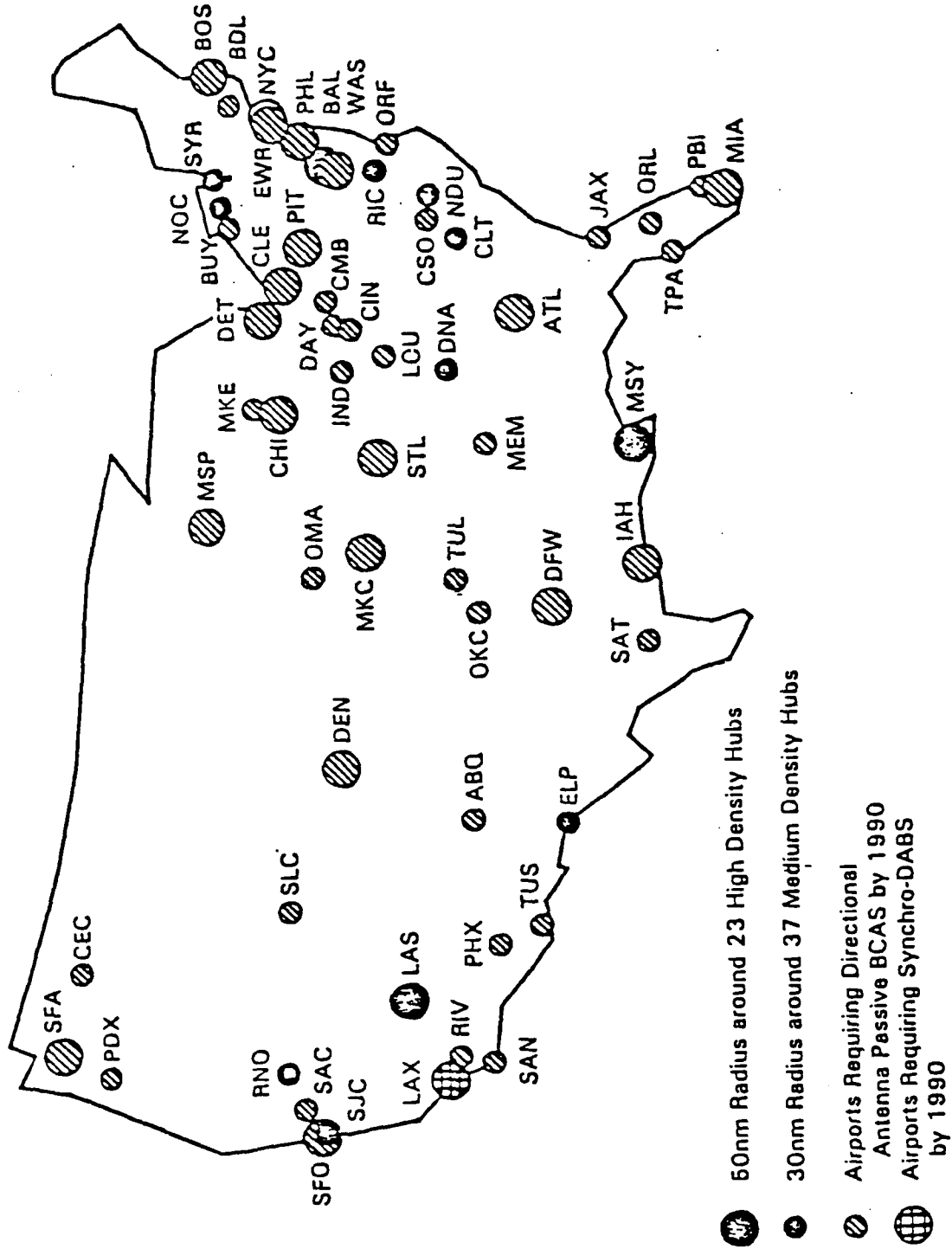
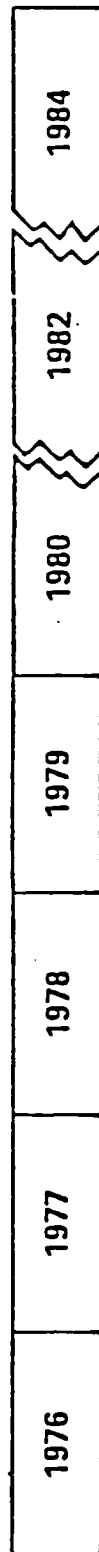

Figure B-26

DABS Development Program Schedule (Calendar Years)



(2/76) ▲ Award Sensor Development Contract

(3/78) ▲ National Standard for DABS Avionics

(6/78) ▲ Award Transponder Contracts

(6/78) ▲ Deliver NAFEC Sensor

(10/78) ▲ Deliver Clementon Sensor

(12/78) ▲ Deliver Elwood Sensor

(6/79) ▲ Deliver Transponders

Single-Sensor Technical Data Package ▲ (4/80)

DABS Implementation Decision ▲ (4/80)

Multi-Sensor Technical Data Package ▲ (4/82)

Begin Delivery of Production Sensors ▲ (7/84)

Figure B-27

ATARS Program Schedule

| Activity | Year | | | | | |
|--|-------|-------|-------|-------|--------|-------|
| | FY-78 | FY-79 | FY-80 | FY-81 | FY-82 | FY-83 |
| Traffic Advisory Service • Concept and Display Development • T&E With Single-Site DABS • Pre-Operational User Evaluation (Tentative) | | — | — | | | |
| | | | — | — | | |
| | | | | — | | |
| Resolution Service • Single-Site — Improve Resolution Algorithm — Evaluation Via Simulation — Performance Evaluation With DABS EM — ATC System Tests • Multi-Site — Algorithm and Code Development — Performance Evaluation With DABS EM | | — | | | | |
| | | | — | — | | |
| | | | | — | | |
| • Technical Data Package — Input to DABS — ATARS | | | | | 4/80 ▲ | |
| | | | | | 4/82 ▲ | |

An apparent and legitimate concern of the FAA is not to be forced to rush into standardizing and introducing a system which is less than perfect with respect to; universal applicability, total reliability, compatibility (in interface) with the pilot (human engineering), interworking with other ground based systems, suitability for future environment, and economic viability.

A systematic search for the desirable system has consisted of FAA's in-house research as well as design and development contracts to outside commercial and non-profit organizations. Thorough testing programs including computerized simulations in projected future airspace environments of busy airports and a series of well-planned test flights form the FAA's Airspace Safety Assurance Plan (ASAP). The results of the ASAP will lead to conclusions to be utilized as feedback for the perfection of system design.

There are FAA plans to issue national standards for a basic BCAS design towards the end of 1978, [21] which will be effective only in uncontrolled airspace. The design of a full capability BCAS is proceeding and aimed at universal applicability to all air traffic and sections of airspace by the 1990's. It is generally believed by those directly involved with the collision avoidance problem [21] that the final system will incorporate a melding of the best of many earlier proposed techniques. These include

Litchford's "passive-mode-listen-in" technique, the single-site SS-BCAS concept advanced by Standford Telecommunications and the single-site-DABS-compatible-BCAS proposed by Mr. Koenke of the FAA.

APPENDIX B REFERENCES

1. Scardina, John A., Automatic Traffic Advisory and Resolution Service (ATSRS), August 1978, System Research and Development Service Progress Report (Aug. 8-9,78), U.S. Dept. of Transportation, FAA.
2. Bagnall Jr., J. J., Collision Avoidance: The State of the Art and Some Recent Developments and Analysis. Navigation (Fall 1976).
3. Zellweger, Dr. A. G., Productivity and Safety of Control Process, Proceedings of FAA's Consultative Planning Conference, (Mar. 22-23, 1978).
4. Morgenstern, B. and Telsch, R., A Description of the Phase I Automated Terminal Service Concept, FAA Report No. FAA-EM-76-6, (November 1976).
5. Ditmore, M. A. and Rucker, R. A., TCA/ERS Stage III Cost Study. FAA Report NO. FAA-EM-76-7, July 1976.
6. Article in Aerospace Safety, U.S. Government Printing Press (May 1976, p: 28).
7. Theberge, Norman, The Impact of a Proposed Active BCAS on ATCRBS Performance in Washington, D.C. 1981 Environment. FAA Publication FAA-RD-77-140 (September 1977).
8. ANTC Report #117, Airborne Collision Avoidance System, (March 24, 1972).
9. Andrews, J.W. and Doegler, J. C., IPC Design Validation and Flight Testing - Interim Results, FAA Document No. FAA-RD-76-22.
10. Bagnall, Jr., J. J. etal, A Review and Analysis of the Honeywell Collision Avoidance System - Phase I. FAA Document No. FAA-RD-73-151,1, (February 1976).

11. Toerper, K. E., MiniCAS Field Acceptance Test Results. FAA Report, FAA-RD-75-223, (December 1975).
12. Toerper, K. E., Time/Frequency Collision Avoidance System Equipment - Phase I - Development Model Ground Station and Associated Airborne Feasibility Models. FAA Report No. FAA-RD-75-223, (December 1975).
13. Bagnall, J. J., etal, A Review and Analysis of the RCA CAS Phase I. FAA Report No. FAA-RD-73-152, (October 1973).
14. Litchford, G. B., Avoiding Midair Collisions. IEEE Spectrum, (September 1975).
15. Litchford, G. G., Avoiding Midair Collisions. Airline Pilot, (February 1976).
16. Gabel, D., Pilots Demand Anti-Collision Equipment Following Disaster. Electronic Engineering Times, (October 2, 1978).
17. McIntire, O. E., Beacon Collision Avoidance System, Systems R&D Service Progress Report, FAA Report No. FAA-RD-78-90, (August 8-9, 1978).
18. Theberge, N., The Impact of a Proposed Active BCAS on ATCRBS Performance in Washington, D.C. 1981 Environment. FAA Report No. FAA-RD-77-140, (September 1977).
19. Scardina, J. A., Automatic Traffic Advisory and Resolution Service (ATARS). System R&D Service Progress Report. FAA Report NO. FAA-RD-78-90, (August 8-9, 1978).
20. Goodwin, J. W., IPC - Phase I, Operational Test and Evaluation. FAA Document No. FAA-RD-77-125, (October 1977).
21. Klass, P.J., Collision Avoidance Standard Prepared, Aviation Week & Space Technology, September 4, 1978.
22. AATMS Program Office, Advanced Air Traffic Management System Study Overview. FAA Document NO. DOT-TSC-OST-75-32, (June 1975).

APPENDIX C

INTERCOM/INTERPHONE SYSTEMS

AND

VOICE COMMUNICATIONS SYSTEMS

INTERCOM/INTERPHONE SYSTEM

The Intercom/Interphone (IC/IP) system provides the majority of the ground-ground voice communications within the NAS. The major constituents of this system are the voice switching and other communications equipment employed at operational FAA facilities and the common carrier networks. The IC/IP system was selected for in-depth analysis because of the variety of equipment employed and because the system is in need of major technological upgrading to provide for expansion, improved performance and reduced recurring costs.

SYSTEM BACKGROUND AND STRUCTURE

The National Airspace System (NAS), utilizes the FAA IC/IP network for ground-ground voice communications for Air Traffic Control. The primary FAA facilities served by the IC/IP network (numbers from ATC Fact Book dated June 30, 1978), presently consist of:

| <u>FAA Facility Type</u> | <u>Number of Facilities</u> |
|------------------------------|-----------------------------|
| ARTCC (Foreign and Domestic) | 25 |
| TRACON | 218 |
| Towers | 496 |
| FSS | 319 |

The IC/IP network as shown in Figure C-1 provides voice communication within and between FAA facilities, and with non-FAA telephones (local and long-distance). The structure of the FAA telecommunications network, containing the IC/IP system, is shown in Figures C-2 and C-3 [2].

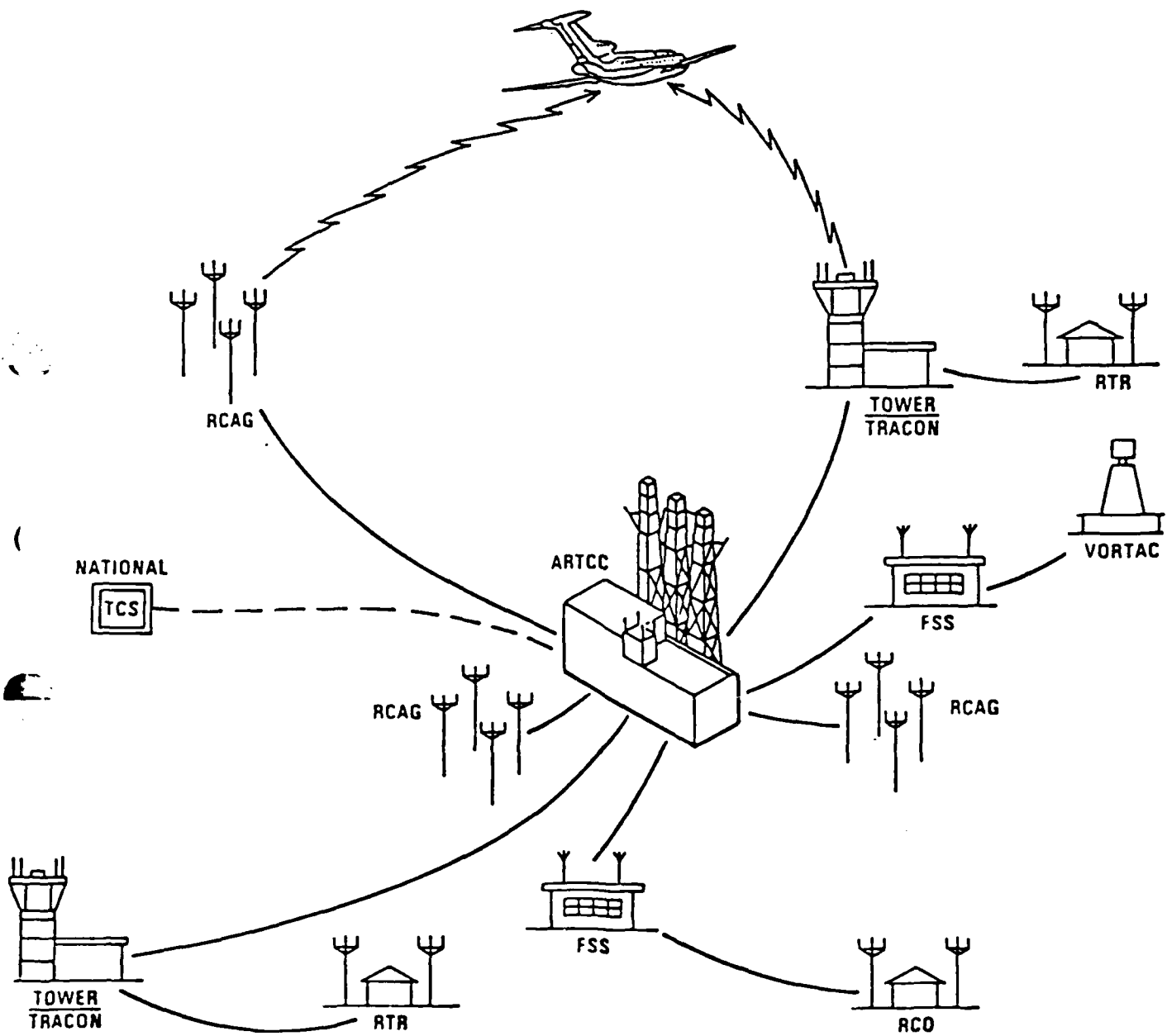

FAA AIR TRAFFIC SYSTEM

Figure C-1

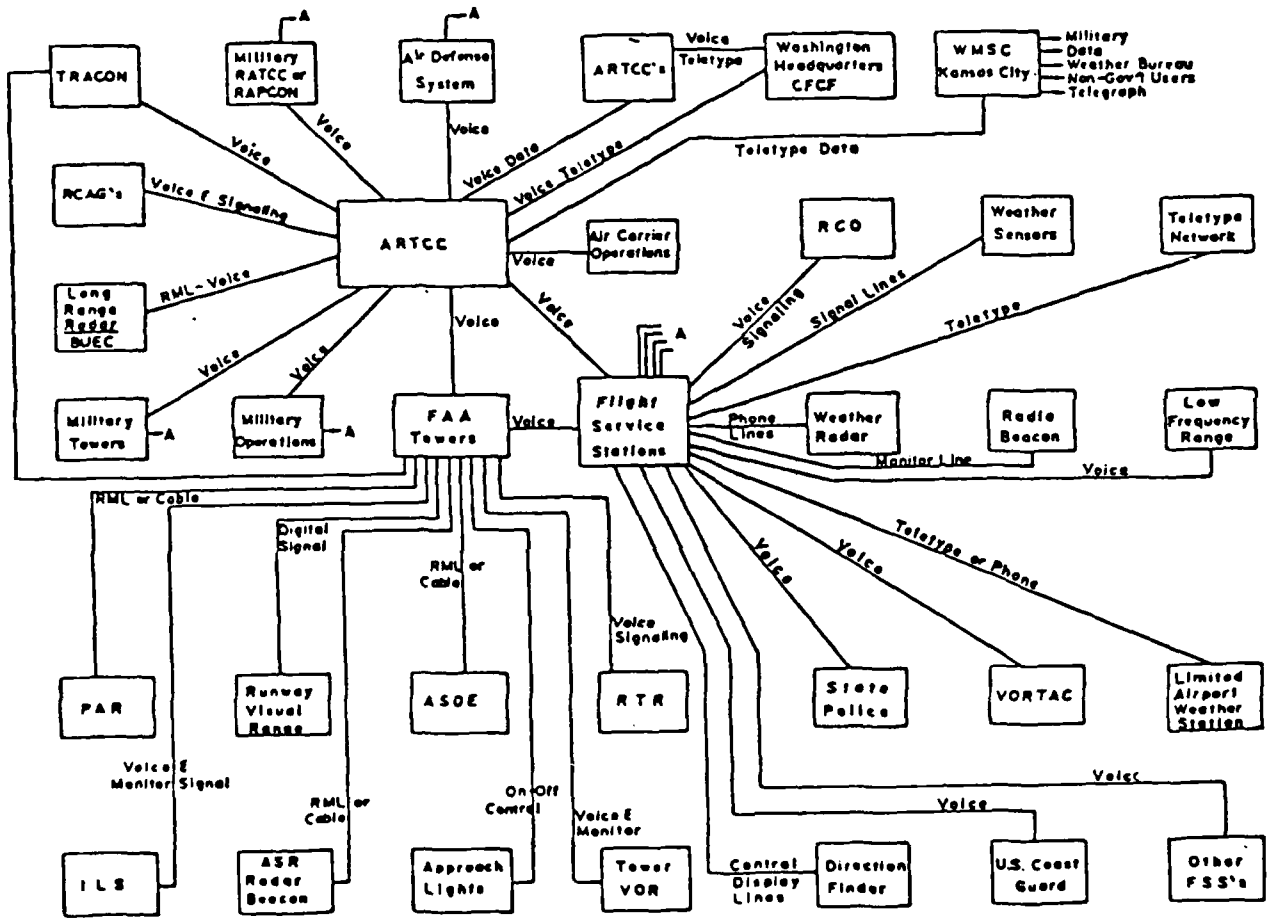

FAA COMMUNICATIONS NETWORK

Figure C-2

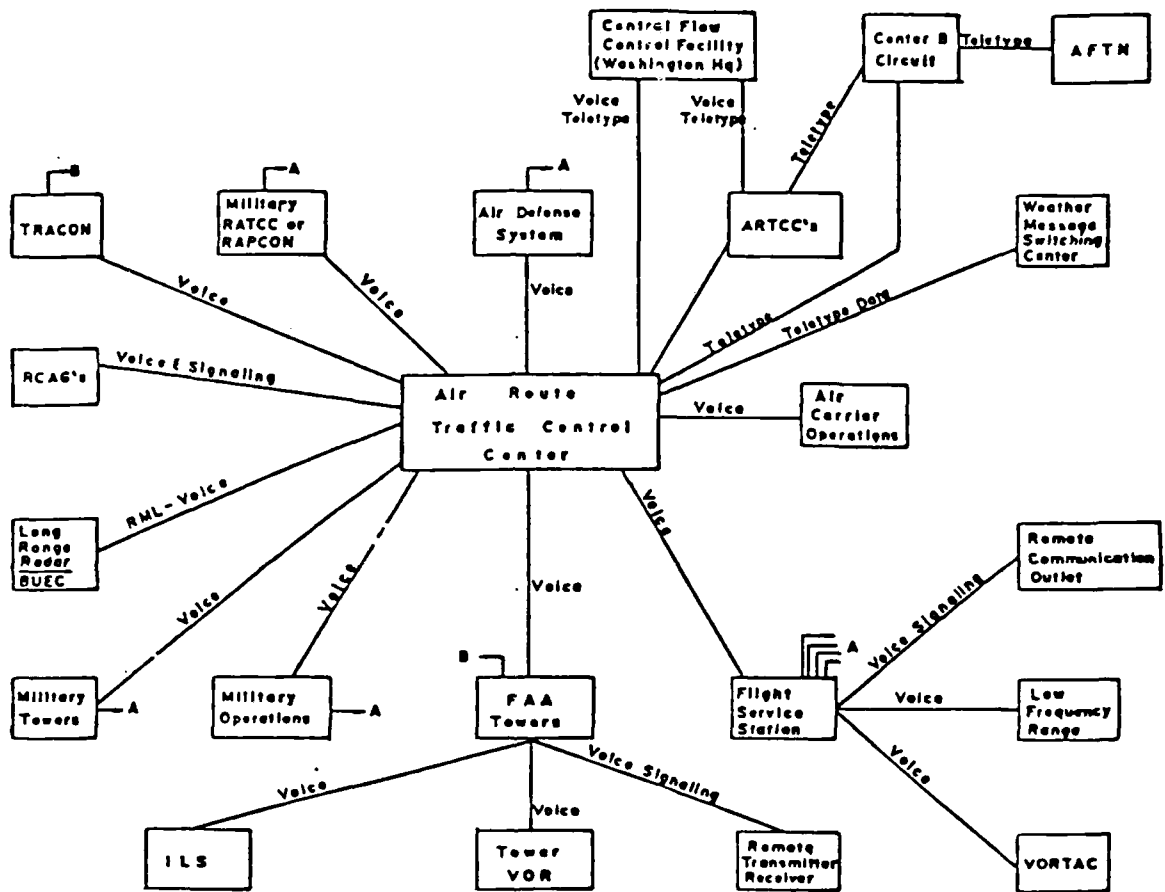

FAA TELECOMMUNICATIONS SUBNETWORK BASED ON ARTCC

Figure C-3

For several decades, the FAA has utilized leased TELCO switching and key systems, viz:

- o WECO 304 Conferencing System
- o WECO 300 Switching System
- o WECO 301 Key Telephone System
- o WECO 1A, 1A1, 1A2 Key Telephone Systems
- o WECO CD#4A, ACD#2A and 2B
- o WESCOM 928 ACD, 920 Key Telephone System

More recently, the FAA acquired the Terminal Communications Switching System (TCSS) which is operating at the Dallas/Fort Worth ATCT/TRACON.

The WECO electromechanical systems in use since the early 1950's, (namely the #300 and #301) have been modified but still have certain inadequacies which preclude efficient service in present and future environments, e.g.,:

- o Rapid reconfiguration/reassignment of position communication capabilities is not possible.
- o Incoming calls cannot be forwarded from the called position to any other desired position.
- o The expansion or change in layout of an in-place system is very costly and time consuming.

In addition to the IC/IP systems which serve ATC requirements and maintenance communication, the major FAA facilities are served by leased TELCO Administrative PABX's. These PABX's provide both internal connections within the FAA facility, and external contact through the

commercial TELCO Direct Distance Dialing network and the Federal Telecommunication System (FTS).

The FAA is in the process of defining state-of-the-art switching systems to serve the future requirements of its extremely critical voice communications. Computer controlled, all solid-state systems with high availability, operational economy and extreme flexibility, are being evaluated. As a result of the basic requirements analysis and planning efforts, a number of research, design and development programs have been initiated and are being pursued by FAA.

Recent Past Programs:

- o Electronic Voice Switching System (EVSS)
- o Integrated National Airspace Communications System (INACS)
- o Terminal Communications Switching System (TCSS).

Current Programs:

- o Small Voice Switching System (SVSS)
- o Voice Switching and Control System (VSCS)
- o NAFEC Communication Switching System (NCSS).

Present FAA strategy is to sponsor the development of two voice switching systems which are of a modular design so that they can be configured to satisfy operational needs over the complete range of from the smallest ATCT and FSS systems to large center systems. Systems will include the radio function as well as the IC/IP Expanded technical control capability will be provided.

Programs will be structured so that the systems can be acquired by either purchase or lease, depending upon the results of future cost studies and FAA funding appropriations. The success of the TCSS has demonstrated that system purchase with the FAA assuming total responsibility is a viable approach.

The EVSS and INACS programs are briefly discussed in the following paragraphs. The TCSS program resulted in an operational system and is described in Section IV.

A. Electronic Voice Switching (EVS) System

In the early 1970's the FAA issued a specification for the EVS system for use at the centers (ARTCCs) and defined the requirements in broad terms. The purpose of the specification was to evaluate the vendor proposed techniques and equipment for the effectiveness of the approach [3]. The EVS System capacity was defined as the capability for interfacing with up to 250 ATC positions at an ARTCC and more than 800 voice lines to other locations.

The system was conceived as a replacement for the existing leased switching systems currently used as a cornerstone in the FAA communications network. In addition to satisfying the basic switching functions and demands on the normal and new operational features, maintenance requirements were minimal. The EVS system was required to be flexible for fast reconfiguration, accommodate

additions and deletions to allow orderly growth and, require a minimal on-site installation effort. The initial and final configurations of the EVS system concept are shown in Figures C-4 and C-5.

The EVS system was designed to perform all the basic IC/IP network functions, i.e.,

- o Intercom
- o Interphone
- o Administrative PABX
- o Air-Ground Communication
- o Remote Control Switching of PTT and main/standby units

The switching system concept included the following new features for FAA IC/IP systems:

- o Remote control: The operation of facilities of one ARTCC from an adjacent center when operational justification for such activity existed.
- o Reconfiguration: the automatic reassignment of communications from one ATCC position to another preassigned ATC position, on automatic direction (via date entry) from the NAS Center Computer Complex.
- o Tandem Switching: the automatic trunk-to-trunk switching capability for alternate voice/data circuits on a non-blocking basis.
- o Fast Connection Time: 300 ms maximum response time for all switched connections.

The types of positions in the ATC to be served by the EVS system included:

- o Radar Controller's Position: For contact with aircraft (e.g., arrival, departure reporting, etc.)

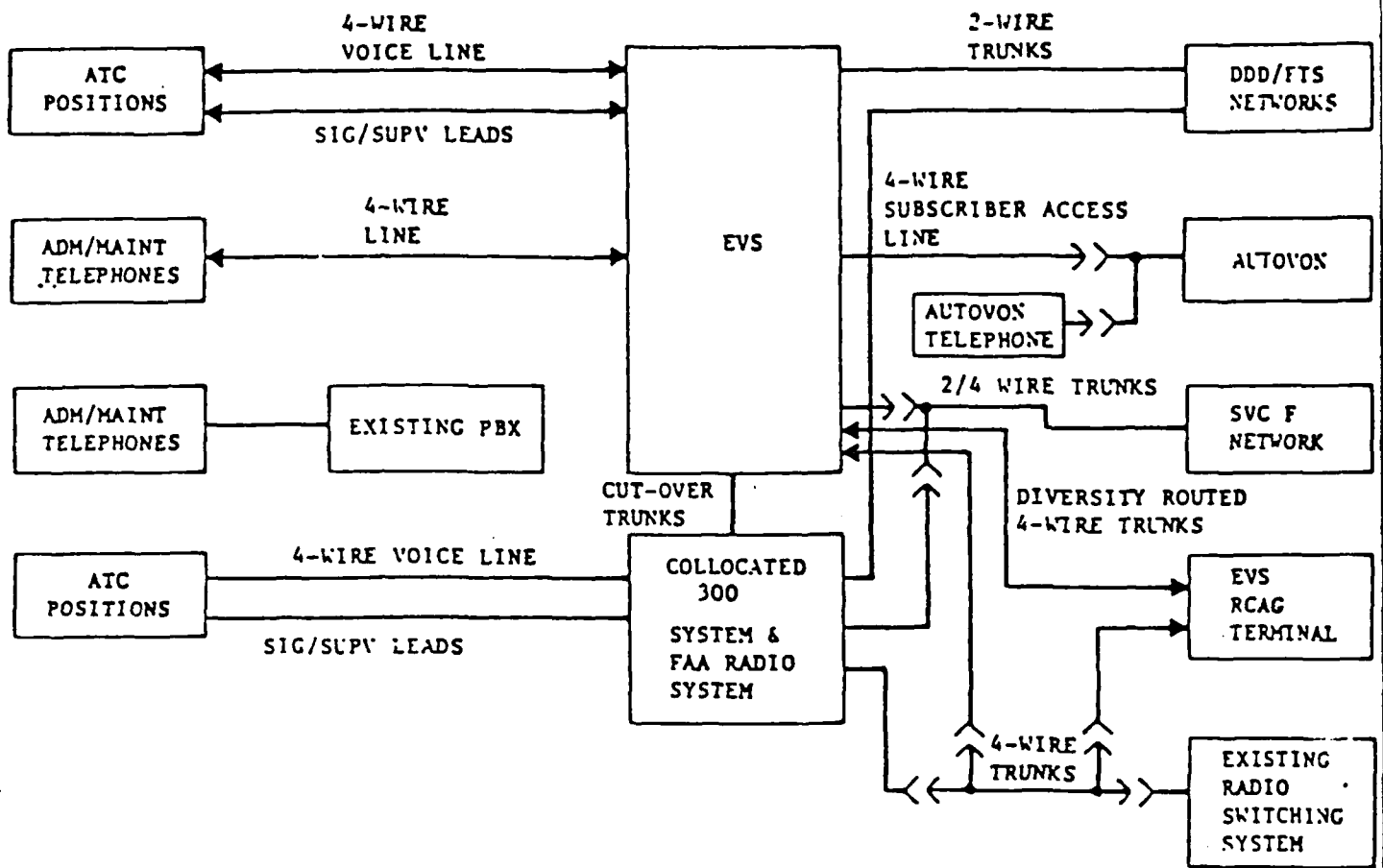

EVS System Environment - Initial Configuration

Figure C-4

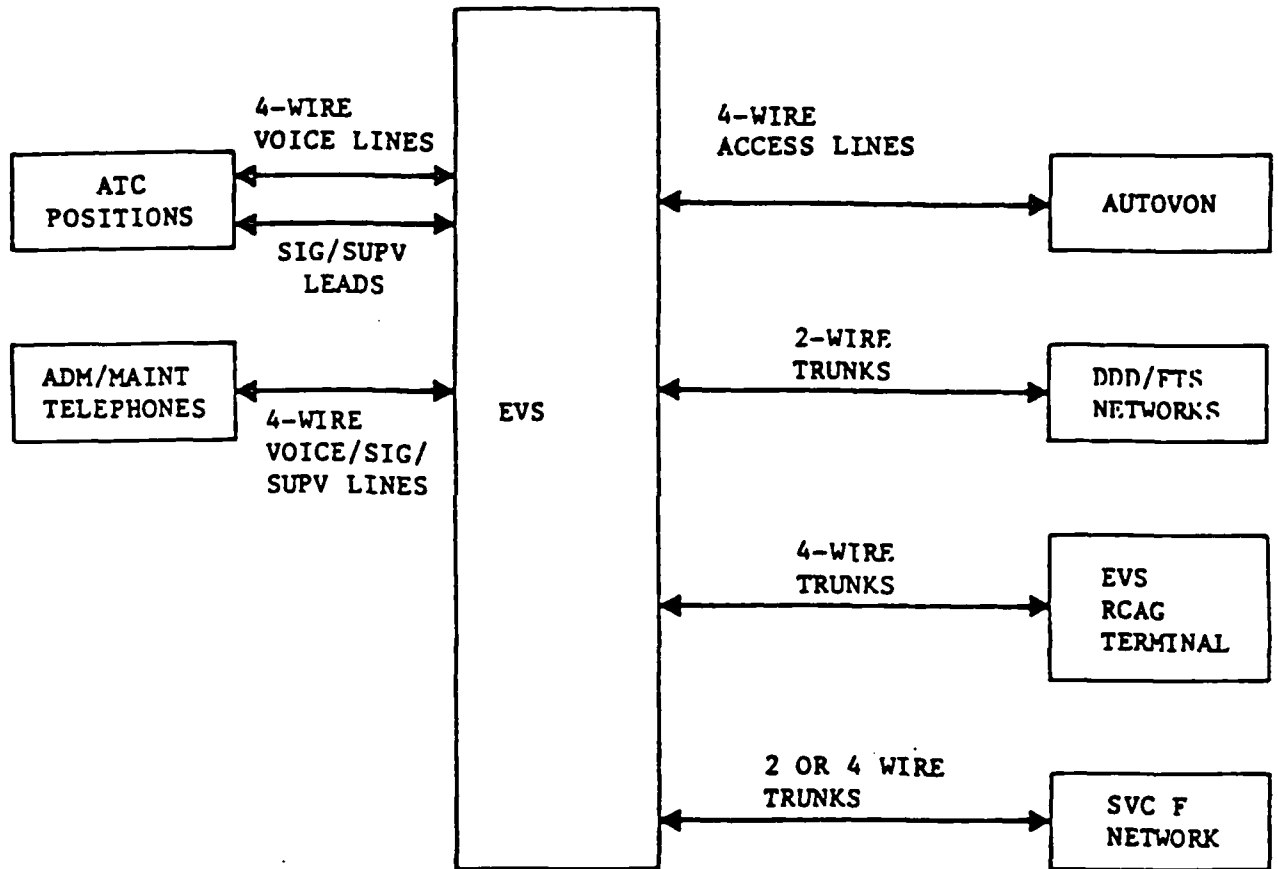

EVS System Environment - Final Configuration

Figure C-5

- o Handoff Controller's Position: For all telephone communications (intercom/interphone) pertaining to handoff of all aircraft.
- o Manual Controller Position: for update of flight strips from information received through the interphone/intercom.
- o Assistant Controller's Position: for accepting flight plans and other flight information via the intercom/interphone.
- o Coordinator's Position: for intercom/interphone communications in particular with the radar controllers it coordinates.
- o Supervisory Positions: for intercom/interphone contact with the other operational positions, e.g., watch supervisor, flow controller, systems engineer.

"The EVS program had been expected to produce significant future cost savings. However, a careful review of the development program indicated little assurance of the anticipated economic benefits. Therefore, the EVS program has been canceled and effort is now focused on alternative approaches for achieving the desired capability on a timely and economical basis." [4]

B. Integrated National Airspace Communications System (INACS)

The INACS program was initiated by the FAA in the mid 1970's to produce a design for a comprehensive state-of-the-art integrated FAA communications network to support the projected requirements for air traffic control operations in the 1980's and 1990's. Although the INACS program was terminated before any hardware procurement action was initiated, it was productive. The INACS system

design effort has provided an excellent foundation for development of new FAA voice switching systems and many of the design concepts are still considered valid and are being pursued in the current programs.

1. System Configuration

The INACS subsystem designs were developed initially to perform discrete tasks and then integrated into a system to exploit to the maximum the capabilities of shared facilities, networks, switching nodes and control and monitoring. The INACS hierarchy is shown in Figure C-6.

The INACS subsystems were envisaged to be:

- o Voice Communications Subsystem (VCS)
- o Radio Communications Subsystem (RCS)
- o Data Communications Subsystem (DCS), and
- o Technical Control Subsystem (TCS).

These subsystems were designed to share the switching devices, configuration elements, concentrators, multiplexers, and leased/owned transmission facilities. Each subsystem (except TCS) was capable of a stand-alone operation, whereas the TCS was to interface with each of the three other subsystems to establish coherent INACS technical control.

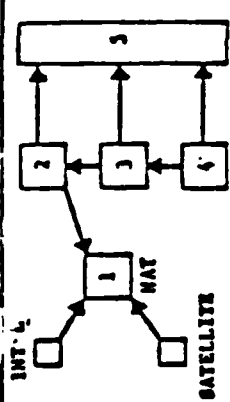

LEGEND

1 NATIONAL NODES
 2 REGIONAL NODES (ARTCCs) ETC.
 3 AREA NODES (LARGE TRACONS, FSS HUBS)

4 TERMINAL NODES (LARGE TOWERS, AIRLINES, MIL BARSOPS SHALL TRACONS)
 5 REMOTE SITES

HIERARCHY LEVELS

| LEVEL | CANDIDATE FACILITY | CONNECTIVITY | FUNCTIONS | GENERALIZED ILLUSTRATION |
|---------------------|---|--|---|--------------------------|
| 1 NATIONAL NODES | <ul style="list-style-type: none"> • SCC • MFDC • NATCON • NADIN SV. CENTERS • NETWORK CONTROL CENTERS (SELECTED ARTCCs OR OTHER FACILITIES) | <ul style="list-style-type: none"> • DATA, VOICE & ORDER WIRES TO OTHER NATIONAL NODES, ALL REGIONAL NODES AND MAINTENANCE CONTROL CENTERS. • DATA, VOICE AND ORDER WIRES TO INTERNATIONAL AND MILITARY INTERFACES AND SATELLITE SYSTEMS; | <ul style="list-style-type: none"> • SYSTEM CONTROL • SYSTEM STATUS • IMACS DATA BASE • VOICE AND DATA OPERATIONAL TRAFFIC TO NATIONAL CENTERS • EMERGENCY CONTROL • SOFTWARE MAINTENANCE • SYSTEM MODIFICATIONS • INTERNATIONAL INTERFACES • SATELLITE INTERFACES • NATIONAL DEFENSE INTERFACE | |
| 2 REGIONAL NODES | <ul style="list-style-type: none"> • ARTCC/FSS (PDB) • ARTCC/FSS (LIN) • ARTCC • AEROSAT TERMINALS | <ul style="list-style-type: none"> • DATA, VOICE AND ORDER WIRES TO NATIONAL CENTERS. • DATA, VOICE AND ORDER WIRES TO ADJACENT 2 NODES • DATA, VOICE AND ORDER WIRES TO TRACONS, FSS HUBS AND TOWERS WITHIN THE GEOGRAPHICAL BOUNDARIES OF CONTROL AND OPERATIONS. • DATA, VOICE AND ORDER WIRES TO ALL REMOTE CONTROL FACILITIES | <ul style="list-style-type: none"> • SWITCHING AND ROUTING OF CENTER-CENTER AND NATIONAL TRAFFIC. • SWITCHING AND ROUTING OF AREA TRAFFIC ORIGINATING OR TERMINATING AT A 2 NODE OR 3 NODE OR NATIONAL CENTERS • REMOTE SITES COMM. & CONTROL • CENTRALIZED MAINTENANCE CONTROL. | |

0- ARTCCs, TRACONS, FSS HUBS, SELECTED TOWERS MILITARY CENTERS ETC.

INACS Hierarchy Concept

| LEVEL | CANDIDATE FACILITY | CONNECTIVITY | FUNCTIONS | GENERALIZED ILLUSTRATION |
|---|---|---|--|--------------------------|
| <ul style="list-style-type: none"> 3 AREA NODES | <ul style="list-style-type: none"> LARGE TRACON FSS (FDB) FSS (LHM) | <ul style="list-style-type: none"> DATA, VOICE AND ORDER WIRES TO SELECTED REGIONAL NODES DATA, VOICE AND ORDER WIRES TO TERMINAL NODES AND MAINTENANCE CONTROL CENTERS LOCAL AREA DATA, VOICE AND ORDER WIRES TO OTHER SELECTED TERMINAL AREA NODES AS NEEDED | <ul style="list-style-type: none"> SWITCHING AND ROUTING OF TERMINAL AREA TRAFFIC ORIGINATING AND TERMINATING AT THOSE NODES FROM AND TO THE ORIGINAL AND NATIONAL NODES SWITCHING AND ROUTING OF TRAFFIC BETWEEN TERMINAL NODES AND FROM AND TO TERMINAL NODES ORIGINATING OR TERMINATING AT AREA, REGIONAL, OR NATIONAL NODES. CENTRALIZED MAINT. CONTROL | |
| <ul style="list-style-type: none"> 4 TERMINAL NODES | <ul style="list-style-type: none"> SMALL TRACON LARGE ATCT CONCENTRATOR SITE | <ul style="list-style-type: none"> DATA, VOICE AND ORDER WIRES TO SELECTED TERMINAL AREA NODES AND SELECTED MAINTENANCE CONTROL CENTERS DATA, VOICE AND ORDER WIRES TO LOCAL AREA INSTALLATIONS | <ul style="list-style-type: none"> CONCENTRATION, SWITCHING AND ROUTING OF TERMINAL TRAFFIC FROM THESE NODES TO AREA NODES CONCENTRATION, SWITCHING AND ROUTING OF TRAFFIC BETWEEN LOCAL AREA INSTALLATIONS CONNECTED TO THE NODE | |
| <ul style="list-style-type: none"> 5 REMOTE SITES | <ul style="list-style-type: none"> SMALL ATCT REMOTE SITES PSBT | <ul style="list-style-type: none"> SITES TO LEVEL 2, 3 OR 4 NODES, AS APPLICABLE | <ul style="list-style-type: none"> DATA, VOICE, CONTROL, AND MONITORING INFORMATION EXCHANGE WITH THE CONTROLLING INSTALLATION | |

Figure C-6 (continued)

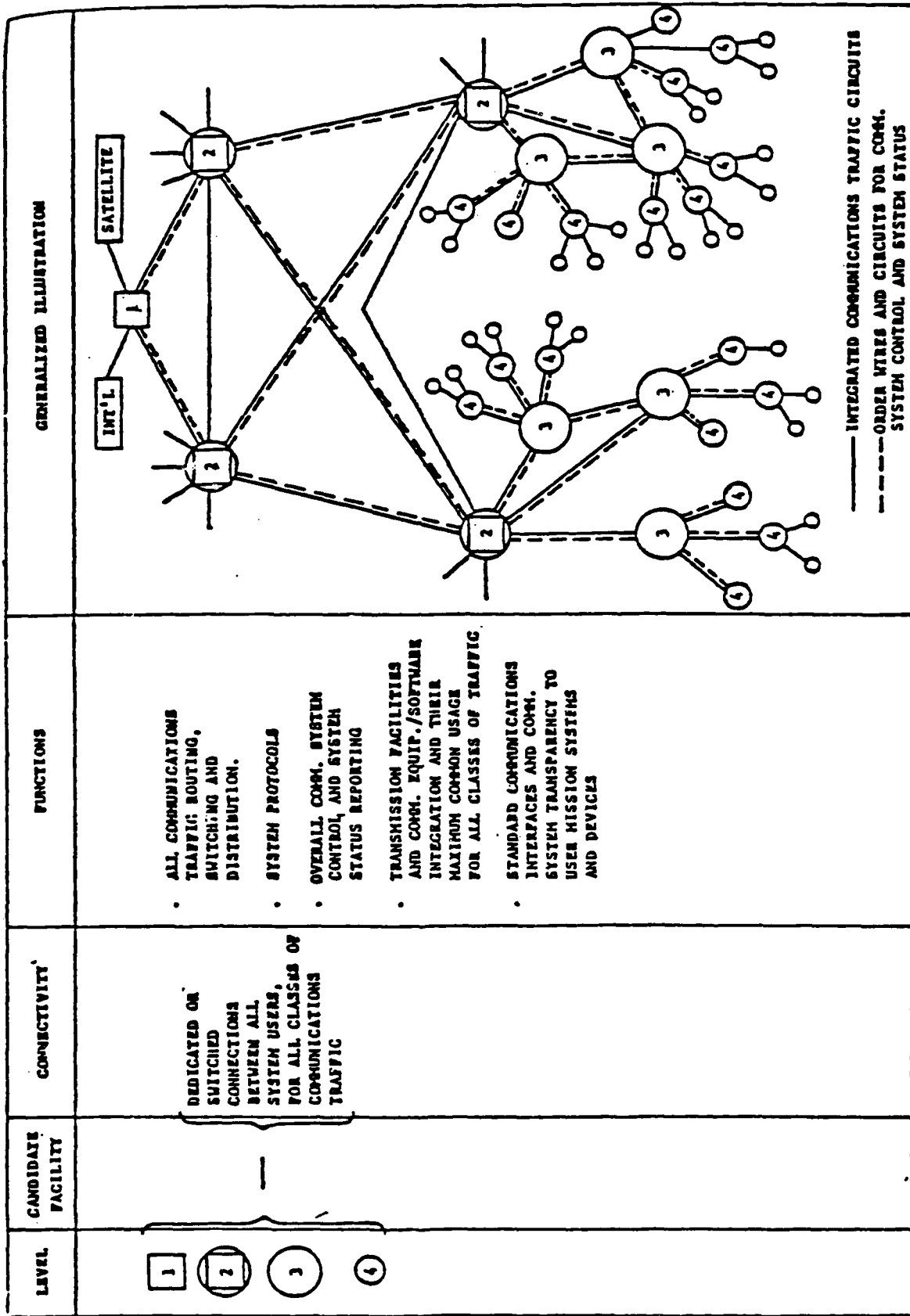

Figure C-6 (continued)

2. Features

The INACS features include some unique and advantageous means of increasing the operational capabilities and reducing costs by:

- o Reduction of the number of dedicated switching systems, by integrating voice/radio/data switching.
- o Reduction of leased transmission links by a common traffic routing/distribution hierarchy, and the common use of leased facilities by voice/radio/data, as well as centralized traffic flow management and control from the local/regional/national centers.
- o Minimizing failures and associated repair effort by:
 - using high reliability devices,
 - eliminating the maintenance visits to remote sites by using an automated centralized technical control and maintenance console for remote monitoring of the status, and for the restoration of service,
 - use of a centralized data base, maintained at regional/national centers to indicate the updated status of remote equipment.
- o Minimizing maintenance efforts by programmable software control and modular hardware/software packages for affecting the changes, deletions, rearrangements and addition of new services without interruption/degradation of operations.
- o Reduction in the logistics/training effort by the utilization of general purpose common modules/assemblies in all INACS subsystems.
- o Reduction in service interruptions by an automatic switchover strategy based on fault trend detection on the critical parameters aided by local/remote diagnostics both on-line and off-line.
- o Reduction in travel time for the FAA technicians by centralized certification of remote FAA site equipment.

3. The Switch Element

This element provided circuit switching functions including alternate routing and tandem switching. Two types of switching units were defined, the "local" and the "remote".

The local switch included:

- o technical control switching stages for voice/radio/data,
- o switching stages for voice/radio/data,
- o common switching stages,
- o tandem switching stages, and
- o Stored Program Control element.

The "remote" switches provided "far-end" switching under the control of a central Stored Program Control element by utilizing command and control telemetry signals. A loop back capability was also included in these switches to assist in remote testing, fault isolation, diagnostics and remote FAA certification.

4. The Voice Communication Subsystem

The structure of this element is shown in Figure C-7, together with the other pertinent details explaining the VCS and its components [5]. The design of this subsystem provides all the normal standard/optional ground-ground voice functions required for the en route, terminal, FSS, national/international ATC

CANDIDATE FACILITY

VCS
FINAL INTERF

CLASS-DEPENDENT OPTIONS

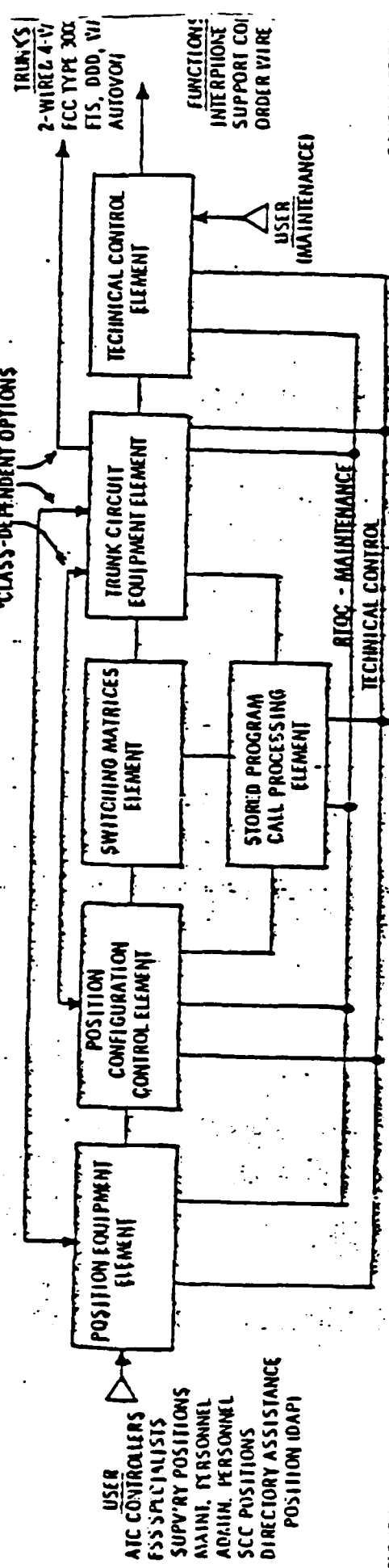

USER
ATC CONTROLLERS
FSS SPECIALISTS
SUPV'RY POSITIONS
MAINT. PERSONNEL
ADMIN. PERSONNEL
SCC POSITIONS
DIRECTORY ASSISTANCE
POSITION IDAP

ELEMENT FUNCTIONS

IP, IC, & SC CALLS
DA & IA CALLS
CALL FORWARDING
OVERRIDE
CONFERENCE CALLS
POSITION MONITORING
PUSH-TO-TALK (PTT)
VISUAL-AUDIBLE SIGNALS
DIRECTORY ASSISTANCE
POSITION IDAP

SECTOR ASSIGNMENTS
POSITION ASSIGNMENTS
PIT CONTROL
PIT LOCK-OUT
CONTROL SIGNALING
CONTROL SUPERVISION
SECTOR/POSITION LINE
TERMINATION
POSITION RECORDING
AUTO. CALL DISTRIB. (ACD)
VOICE RESPONSE SUB-SYSTEM (VRS)

INTERPHONE SWITCHING
INTERCOM SWITCHING
SUPPORT COMM. SWITCH
STORED PROGRAM CONTROL
IP CALL PROCESSING
IC CALL PROCESSING
SC CALL PROCESSING
MONITORING
TRUNK-TO-TRUNK SW.
TRAFFIC MEASUREMENTS

IP TRUNK CKT. INTERFACE
SC TRUNK CKT. INTERFACE
TRUNK MONITORING
LINE & TRUNK TEST
TRUNK CONDITIONING

REAL-TIME-QUALITY-CONTROL (RTQC)
TRUNK SELECTION
TRUNK RESTORATION
AUTO. SELF TEST
CENTRALIZED MAINT. ACCESS
SUBSYSTEM STATUS DISPLAY
ON-LINE/OFF-LINE TEST
TANDEM SWITCH CONTROL

CANDIDATE FAC FOR CONNECTIV

ARTCCs
TRACONs
ATCS
HUB FSSs
SATELLITE FSS
AEROSAT TEF
SCC
NATCOM
RAPCON/RA
MIL BASOPS

FUNCTIONAL MODULES

HEADSET
SUPPORT COMM. INSTRUMENTS
SPEAKER
DIALER
DA PUSH BUTTON (PB)
IA PUSH BUTTON
INDICATORS
AUISC. CONTROL PBs & SPARES
DAP UNIT

ASSIGNMENT MATRIX
DA/IA/PTT CONTROL
MULTIPLE TRUNK SEL.
LINE ROTARIES
RTQC UNITS
ACD UNIT
VRS UNIT
SECTOR/POSITION IDF

IP SWITCH NETWORK
IC SWITCH NETWORK
SC SWITCH NETWORK
COMMON CONTROL PROC.
TAPE UNITS
MEMORY UNITS
MONITORS

IP TRUNK UNITS
SC TRUNK UNITS
TRUNK SUPV'RY & SIGNALING UNITS
LINE/TRUNK TERM. UNITS
TRUNK CONDITIONING UNITS
SUBSYSTEM IDF

TECH. CONTROL MONITORS
TANDEM SWITCH MATRIX
MAINTENANCE CONSOLE
BUILT-IN TEST EQUIP.
TRUNK MDF

VOICE COMMUNICATIONS SUBSYSTEM ELEMENTS AND FUNCTIONS

operations in the NAS, and their associated supporting maintenance functions. It is suitable for deployment at all sizes and classes of ARTCCs, TRACONS, ATCTs, Hule FSSs, and the National/International Centers.

II. SYSTEM APPLICATIONS

The IC/IP network provides a media for both internal and external voice communication to the FAA facilities. The basic elements of this network are the switching systems employed at the nodes, e.g., ARTCCs, ATCTs, SCC, FSS, etc.

Each IC/IP switching system serves a number of lines internal to the FAA facility, and a number of trunks connecting it to other FAA facilities and non-FAA locations, either through direct circuits (leased or owned) or the dialed TELCO network. The interconnection of the switching nodes and the various FAA facilities is shown in a matrix format in Table C.1 [1]. A list of prime users of the IC/IP network with type of communication is given in matrix format in Table C.2 [1].

The role played by the IC/IP network in providing FAA voice communication requirements is discussed in the following paragraphs where details on the voice communication requirements of each major type of FAA facility are described.

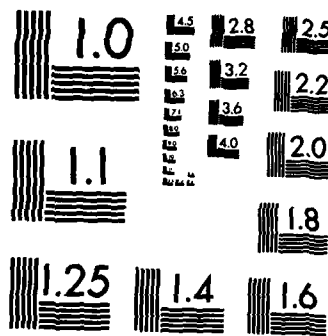

MICROCOPY RESOLUTION TEST CHART
NATIONAL BUREAU OF STANDARDS-1963-A

Table C.1

IC/IP NETWORK TERMINATION FACILITIES

| | |
|---|---------------------------------------|
| Facilities with major switching capability: | ARTCC ATCT/TRACON SCC RAPCON |
| Facilities with minor switching capability: | ATCT CS/T |
| Military Terminations: | BASOPS GCA Tower ARAC |
| Termination on a space available basis: | DDD FTS AUTOVON |
| Pilot Assistance Terminations: | FAS FX WSO |

Table C.2

FAA VOICE (IC/IP) COMMUNICATIONS NETWORK CONNECTIVITY

| Outside Or FAA Facility To/From | ARTCC | ATCT | ATCT/ TRACON | FSS | CS/T |
|---------------------------------------|-------|------|-----------------|-----|------|
| ARTCC | X | X | X | X | X |
| FSS | X | X | X | X | X |
| CS/T | X | X | X | X | X |
| ATCT (private or public) | X | X | X | X | X |
| ATCT/TRACON | X | | X | X | X |
| RAPCON (IFR) | X | X | X | X | |
| RATCC | X | X | X | X | |
| ARAC | X | | | | |
| BASOPS | X | | X | X | X |
| WSO | X | X | X | X | X |
| ADC | X | | | | |
| SAR(USCG) | X | | | | |
| FAA-SCC(CARF) | X | | | | |
| OVERSEAS LINK (ICAO) | X | | | | |
| AUTOVON | X | | | | |
| SOCS | X | | | | |
| ARINC | X | | | | |
| AIRLINES | X | | X | | X |
| PBX/UAS | X | | X | | X |
| FTS | X | | | | |
| CENTREX | X | | | | |
| PILOT BRIEF LOUNGE | | | | X | |
| PRIVATE AVIATION | | X | | | |
| ENTRANCE DOOR | | X | X | | |
| FAS | | X | | | |
| KEY EQUIPMENT | | X | | | |
| FAA-SCC/(CARF) | | | X | | |
| ANG | | | X | X | X |
| FIREHOUSE | | | X | | |
| GCA | | | X | | |
| FX | | | | X | X |
| COMMERCIAL | | | | | X |

The Systems Command Center (SCC) is the focal point for NAS air traffic management and is located at FAA headquarters in Washington, D. C. The SCC includes the following facilities:

A. The Central Flow Control Facility (CFCF)

Part of the SCC, the CFCF maintains both voice, teletype and data communication services to all major elements of the NAS. It also has direct dial connection to all thirty-seven weather radars throughout the nation. Since it functions as a "watch dog" for perturbations in the system that could affect air traffic movement, it must have fast response communications to the principle elements of the NAS.

The SCC primary communications today is a nationwide voice network that can be connected to enable conferencing of any or all of these elements for purposes of forming a direct link between potential problem areas. This is through a leased WECO 304 Conferencing System which permits extensive conference groups to be set up with little effect, and without the transmission degradation normally associated with such connections.

B. Air Route Traffic Control Center (ARTCC)

The Center (ARTCC) is interconnected to all operational aviation facilities within its geographic area of responsibility, including adjacent centers. Centers are equipped with the WECO 300 Switching

Systems that provide several types of circuits. Direct access voice call circuits are used for handoff of radar tracked aircraft between sector positions within the facility and between facilities. These circuits appear as simple user facilities but often with more than one center position. Indirect dial circuits are provided for the handoff of aircraft and the transfer of flight information from positions with relatively light flight activity. Many of these circuits employ voice call signalling outward from the center and allow dialing inward from the remote facility. Multipoint circuits using selective signalling are also employed between the center and remote facilities (from two to fourteen). The multipoint circuits provide interference free transfer of flight information between the FAA and the normal weather, military, or airline subscribers.

Each ARTCC has from 80 to 150 full-period leased external telephone circuits connecting it to operationally related facilities (a TRACON or major ATCT has typically from 20 to 80 such circuits).

An example of the circuit composition at a center is:

| | |
|------------------|-------------------------------|
| Voice Call | 50 percent (direct access) |
| Dial Signal | 28 percent (indirect access) |
| Selective Signal | 22 percent (selective access) |
| | <hr/> |
| | 100 percent |

C. Air Traffic Control Towers (ATCT)

The connections between ATCT and ARTCC, RAPCON and RATCC are provided for coordinating IFR aircraft activity. Connections are also provided to the AREA FSS, or CS/T, to other ATCTs and the Weather Facility. In some instances Flight Advisory Services (FAS) are provided by ATCT. The number of terminations installed at an ATCT depends on the flight activity.

D. Control Towers and IFR Room (ATCT/TRACON)

These FAA facilities provide the terminal area control of all IFR operations at the terminal. The ATCT function controls all aircraft at the terminal. Where the traffic volume is high, the terminal area may be designated a Terminal Controlled Airspace (TCA). This requires all aircraft entering the area to be radio and beacon-equipped.

To control the aircraft, the ATCT/TRACON have to be interconnected to all assigned facilities performing the handoff or accepting the controlled aircraft. Moreover, the same type interconnections will be required as in any other control tower. To handle the controlled aircraft, the ATCT/TRACON is equipped with direct-access voice-call signalling circuits to/from the area center and adjacent terminal facilities.

E. Flight Service Stations (FSS)

The FSS facilities are equipped with leased Call Directors, which distribute the incoming calls over a number of specialists.

These FSS specialists answer calls to provide assistance by:

- o Conducting Pilot Weather Briefing and updating,
- o Filing IFR and VFR flight plans (FPs)
- o NOTAMS (Notices to Airman) verification, correction, advise,
- o Rescue coordination service
- o Direction Finding Coordination
- o NAVAIDS monitoring, verification, advise.

Each FSS has a specific combination of circuit terminations, and the capacity is determined by the grade of the station which in turn is determined by the volume of messages, FPs processed and other operational considerations. An individual FSS may have from 4 to 7 external circuits, (excluding the FX circuits) of which the majority are part of multipoint circuits.

Most FSS facilities receive calls from a center using either voice signalling or dialing-in. The return circuit from the FSS, as well as ATCT and ATCT/TRACON terminations, is almost always a dial-out circuit. The FX circuits are terminated in a key set at a specialists position. At some high activity stations where several FX or FAS circuits are terminated, an Automatic Call Distributor is

provided or a call allotter is included to transfer a waiting call to an available position.

F. Combined Station/Tower (CS/T)

The CS/T, as the name implies, is a hybrid control tower (ATCT) and Flight Service Station (FSS), with both functions performed at the same site but isolated from each other. The number of channels for interphone use is less than the number required for two separate facilities.

SYSTEM DESCRIPTIONS (PRIMARY SYSTEMS)

III. WECO 300 Switching System

The WECO 300 switching system (SS) is a cross bar exchange designed to meet the FAA's special communications requirements. It serves basically the voice coordination of flight movements among controllers 1 and 6 . This system is utilized at the Air Route Traffic Control Centers (ARTCCs), and allows the operating positions served a direct access to specified operating positions (locally within an ARTCC) and remotely to adjacent ARTCCs and terminals, including indirect access to virtually any other operating position. A conceptual block diagram is given in Figure C-8.

The present structure of FAA telephone switching networks dates back to 1956 [7]. At that time the Civil Aeronautics Administration, the American Telephone and Telegraph Company, and Bell Laboratories formulated the requirements for the 300 Switching System. The 300 system was designed to be "extremely adaptable", and able to handle a large volume of calls. It consists of racks of wire-spring relays and crossbar switches installed in an equipment room. It also includes the modules which provide the interface with ATC operators. These are installed in the FAA equipment consoles comprising an operating position as required.

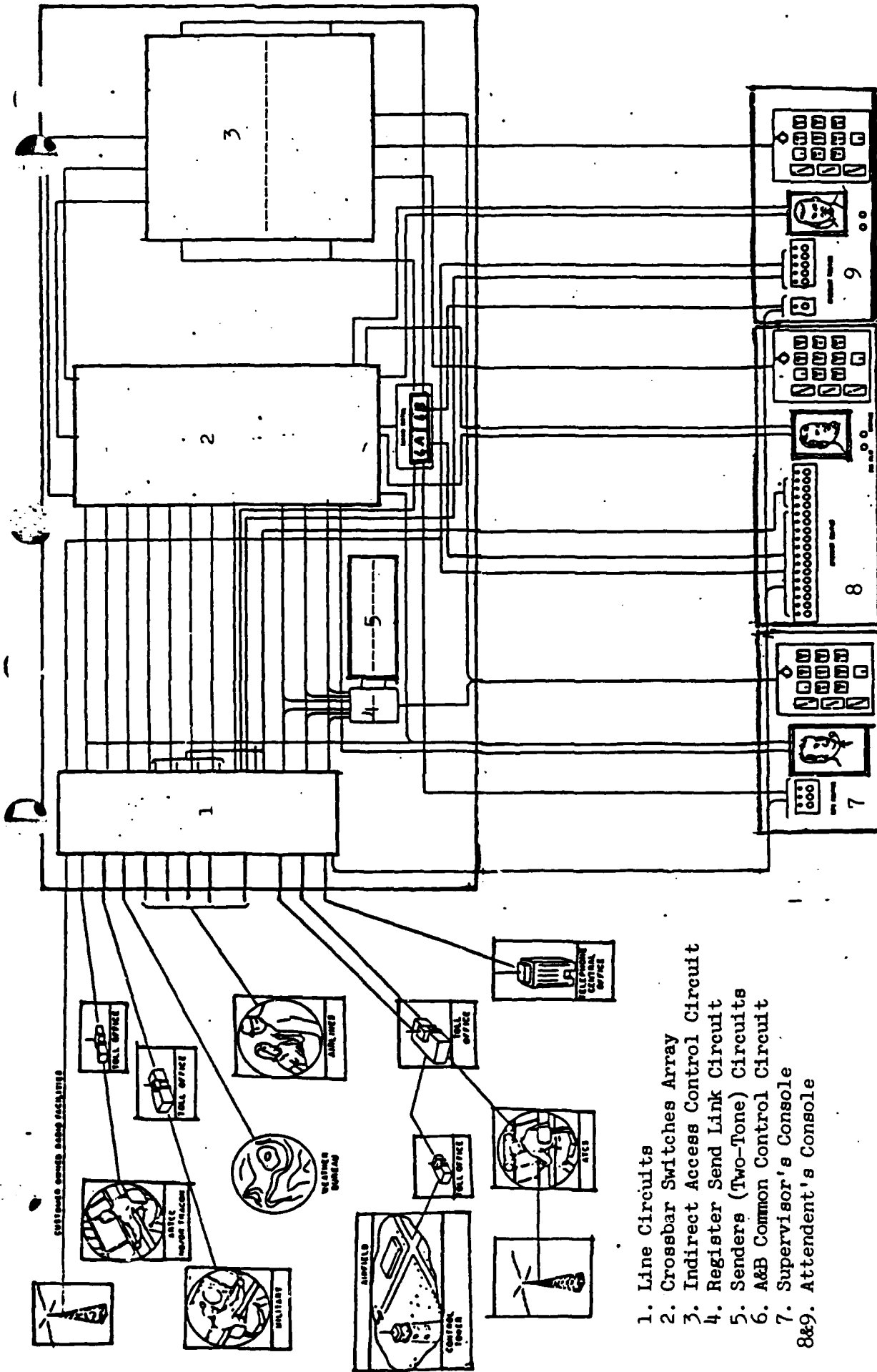

1. Line Circuits
2. Crossbar Switches Array
3. Indirect Access Control Circuit
4. Register Send Link Circuit
5. Senders (Two-Tone) Circuits
6. A&B Common Control Circuit
7. Supervisor's Console
- 8&9. Attendant's Console

Figure C-8
 CONCEPTUAL BLOCK DIAGRAM OF THE WECCO 300 SWITCHING SYSTEM

The primary design parameters of the WECO 300 SS are:

Capacity: 60 to 300 Attendant (Controller) Positions

Technology: Hardwired Dual Common Control; crossbar switches, Step-by-Step Selectors, Relays

Circuits: Switching on 4-W only, accepts 2-W lines through hybrids

Calls-in-Progress: Number not restricted

Access: Unlimited to any position/landline-radio channel.

A. Operational Features

1. Standard Features

The most important features of the WECO 300 SS are:

- o Direct access (DA) for Air Traffic (AT) controller to a number of most-wanted lines, other positions, or aircraft radio channels by operation of a key (one per line).
- o Indirect access (IA) for AT controller to any position or line available to the ARTCC by operation of a push-button dial.
- o Visual indication at a specific position in the ARTCC of incoming interphone calls intended for that position.
- o Arrangements enabling an AT controller to have calls that are directed to his position transferred to another position.
- o Monitoring of a second position by one position (e.g., the coordinator) without the knowledge of the second position.
- o Simultaneous transmission capability on radio and a pre-selected interphone line at a position.

- o Capability for an exchange of position control, whereby the controller can operate the position without exchange of telephone instruments or jacks.
- o Circuit arrangements to permit establishment of connections over dial, manual, or selective signaling lines or connections to air-ground radio facilities singly or in combination.
- o Incoming dial selection of control positions with call storage and sequence answering, and with primary and secondary answering responsibility arrangement on certain lines.
- o Position intercommunication on an override basis so that one position always has access to another, even though it may be busy.
- o Distinctive types of lamp indicators, such as steady, flashing, fluttering, or winking, at positions to indicate the status of a line or call.
- o Individual position blanking of lamp displays to eliminate any unnecessary flashing or steady lamp displays.
- o Provisions for using the position telephone set with FAA-provided radio equipment on an automatic transfer basis; e.g., between interphone lines and radio channels.
- o Audible guard tone signal on dial lines while dialing is in progress.
- o Arrangements to permit simultaneous origination and termination of multiple line and position connections.

2. Optional Features

A number of optional features are provided in WECO 300 SS:

- o Coordinator monitoring (for bridge on to attendant telephone circuit)
- o Improved key illumination
- o Jack transfer (exchange of position control)

- o Line hunting
- o Position sector combining (selective diverting of incoming calls)
- o Simultaneous Radio/Interphone

3. New Optional Features

In addition to the standard and optional features, a number of new features were introduced by American Telephone and Telegraph/WECO in the recent past to make the SS better able to fulfill FAA requirements:

- o Auto redirected override
- o Backlighting/indirect lighting
- o Dual function key (choice of 2 override circuits or dis-association of loudspeaker on voice signalling).
- o Position monitoring (single/dual)
- o Preemption control
- o Remote override
- o Syllabic lamp feature indicating 4 conditions prevailing on line circuits (busy/incoming call/line to which position is connected/hold).
- o Blanking, fluttering indication
- o Position pilot lamp
- o Audible signals: 2 types of chime signalling.

4. Special Positions

A number of special positions included in the system other than the Controller positions follow:

- o The supervisor position is provided to extend services to lines or other attendant positions,
 - urgent call operation
 - control over restricted lines
 - master/subordinate position
- o System Maintenance Monitor Console Position (SMMC). This position is for centralizing and coordinating all maintenance communication for ARTCC. The functions are the same as for the supervisor position, and in addition provide:
 - conferencing key
 - position control key

The SMMC provides for conferencing a maximum of 15 conferees on any one of five conference circuits. These circuits are color designated blue, brown, green, orange and red. The SMMC provides the FAA system engineer or facility coordination officer access to the 300 SS.

- o Control Computer Complex Console Position

The functions of this position include:

- access capability at ATCs radar computer console in the central computer complex.
- voice communication with the SMMC/watch supervisor operation position in ARTCC/peripheral facility, e.g., FSS, tower, other ARTCCs.

B. Equipment Description

The WECO 300 is an electromechanical exchange which can serve up to 120 positions and 240 lines. The capacity of the WECO 300 equipment may be expanded in increments of either 20 positions or 10 lines. A functional block diagram of the system is shown in Figure C-9 [7]. The exchange is capable of interconnecting any of its positions to any of the lines served.

The equipment consists of position equipment and back room equipment. The former is located at the air traffic controller's terminals and includes a number of keys, lamps, indicators, etc. The backroom equipment includes a crossbar switching matrix, associated relays and control equipment as well as the distribution frames, line/trunk interface devices, the power supply and other ancillary equipment.

The representative types of circuits terminating at a WECO 300 exchange at an ARTCC are shown in Figure C-10.

1. Position Equipment

Each WECO 300 Switching System console includes special keys, lamps, loudspeakers and telephone sets providing signalling, switching and voice communication facilities for handling as many as 40,000 calls a day [7]. The 300 SS minimizes the space

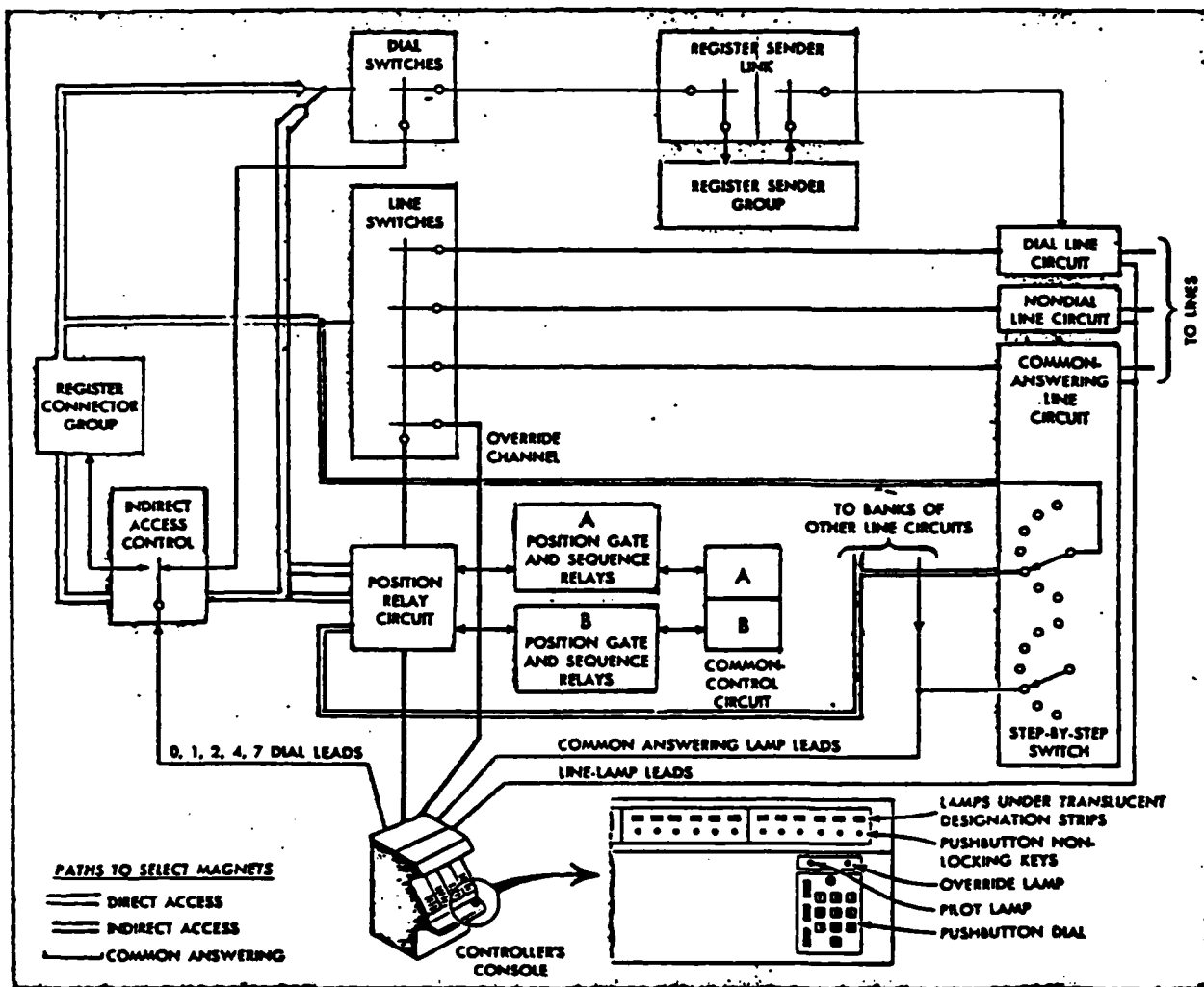

Diagram of one of the two line-contractor frames for the No. 300 Switching System. The number of

register connectors and register senders varies from three to five, depending on size of the system.

Figure C-9

FUNCTIONAL DIAGRAM OF THE WECO 300 SS

Circuit Type *

End Terminal Facility

| End Terminal Facility | FAAN | FAABN | FAACN | FAADN | FAAEN | FAAFN | FAAGN | FAAHN | FAAKN | FAARN | FAATN | FAEBN | FAFCN | FAEBN | MIL | P.L. |
|-------------------------------|------|-------|-------|-------|-------|-------|-------|-------|-------|-------|-------|-------|-------|-------|-----|------|
| ARCC (others) | X | X | | | | | | | | | | | | | | |
| FSS | | | X | | | | | | | | | | | | | |
| CS/T | | | X | | X | | X | | X | | | | | | | |
| ATCT (private or state owned) | | | X | | X | | X | | X | | | | | | | |
| ATCT | | | X | | | | | | | | | | | | | |
| ATCT/TRACON (IFR) | X | X | X | X | X | | X | | X | | | | | | | |
| RAPCON | | | X | X | | | | | | | | | | | X | |
| RATCC | | | X | X | | | | | | | | | | | X | |
| ARAC | | | X | X | | | | | | | | | | | X | |
| BASOPS | | | | X | | | | X | | | | | | | X | |
| WSO | | | | | | | | | | | | | | | | |
| ADC | | | | | | | | | | X | | | | | | |
| SAR (USCG) | | | | | | | | | | X | | | | | | |
| FAA-SCC (CARF) | | | | | | | | | | | | | | | | |
| OVERSEAS LINK (ICAO) | | | | | | | | | | | | | | | | |
| AUTOVON | | | | | | | | | | | | | | | | |
| SOCS | | | | | | | | | | | | | | | | |
| ARINC | | | | | | | | | | | | | | | | |
| AIRLINES | | | | | | | | | | | | | | | | |
| PBX | | | X | X | | | | | X | | | | | | | |
| FTS | | | X | X | | | | | | | | | | | | |
| CENTREX | | | | | | | | | | | | | | | | |
| PILOT BRIEF LOUNGE | | | | | | | | | | | | | | | | |

FIGURE C-10 REPRESENTATIVE TERMINATIONS BY CIRCUIT TYPE TO/FROM ARTCC

*See Table C-2A for explanation of the circuit type codes

Table C.2A

CIRCUIT TYPE CODES

| | |
|-------|--|
| FAAAN | Intercenter Nonradar Circuits |
| FAABN | Intercenter Radar Handoff Circuits |
| FAACN | Center Intra-Area Nonradar Circuits |
| FAADN | Center Intra-Area Radar Handoff Circuits |
| FAAEN | Tower Enroute Circuits |
| FAAFN | Flight Assistance Service Circuits |
| FAAGN | Foreign Exchange FAS Circuits |
| FAAHN | Military Flight Service Circuits |
| FAAKN | Center Facilities |
| FAALN | FSS Facilities |
| FAAPN | Tower Facilities |
| FAARN | Miscellaneous Circuits |
| FAATN | International Cable |
| FAEBN | AUTOVON Staff Communication |
| FAFGN | Regional Miscellaneous Circuit |
| ML* | Military-Supplied Circuit |
| PL* | Private Line |

*All other codes standard to ORDER 4441.3, Change 1, (9/11/69):
Procedures for Leasing Commercial Communications Services.

required at the controller's console and the access time to all lines. Since 90 percent of a controller's calls involve 12 or fewer lines, each one is assigned a "direct access" key. When a controller operates any of these keys he is immediately connected to the desired line. To make an "indirect access" call, the controller presses an indirect-access key, dials a two or three-digit code on a pushbutton dial pad which connects to any line or other controller in the center. .

The supervisor's equipment operates in a similar manner to the controller's equipment, but their consoles have some special features, e.g., direct-access line keys and lamps for every line in the system (for a constant indication of the status of all lines with rapid access to all) [7]. For added security the supervisors' positions have independent facilities for connecting to the lines by direct access. The supervisors connect to the lines by a circuit operating on a relay-per-line basis, and do not utilize the crossbar switch field and common-control equipment.

2. Backroom Equipment

The WECO 300 SS (shown in Figure C-11) is a four-wire switch with FDX, i.e., two wires connected for each of two directions of communication and also has a HDX, i.e., two-wire duplex capability.

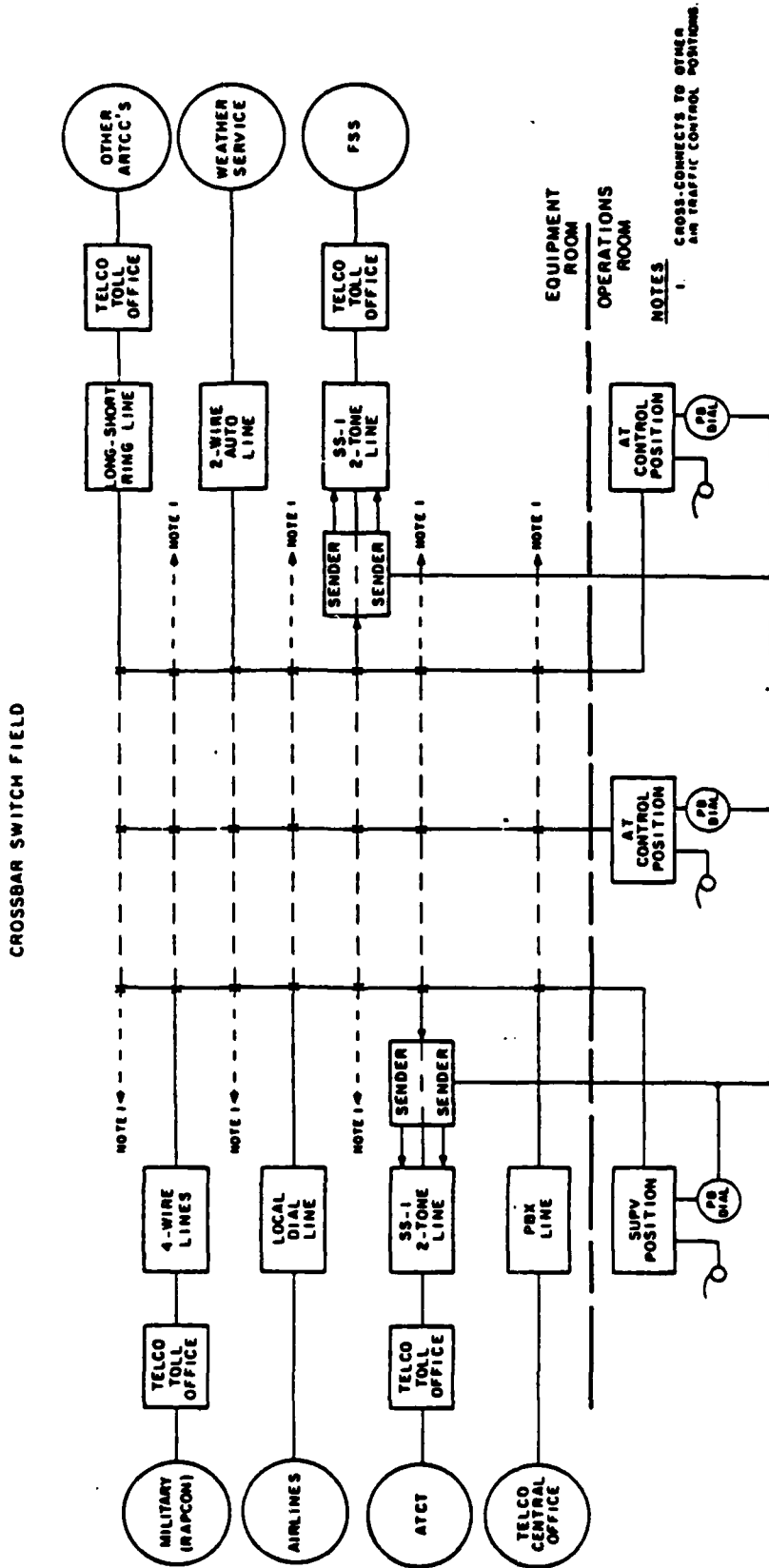

300SS Simplified Functional Diagram

Figure C-11

The standard FAA ATC circuit is four-wire type, but provisions have also been made for interconnection to the FTS network and local PBX circuitry [8]. The switch includes a rectangular grid network of a series of crossbar switches. A crossbar switch consists of a combination of specialized relays in which connections are set up in both horizontal and vertical planes. When properly conditioned, contacts are made at the intersection and locked in by a holding magnet until a change to another combination is made. The point(s) of intersection are known as crosspoints. Each crossbar in the WECO 300 SS consists of 200 crosspoints (Figure C-12). Twenty positions are provided access to any of 10 lines at a crosspoint, and each crosspoint makes six connections. This switch is known as the six-wire crosspoint switch.

3. Additional Lines

Besides the dial lines many other types of lines terminate in a variety of line circuits of the 300 SS [7]. These line circuits provide the proper transmission elements and perform a number of control and signalling functions, e.g.:

- o The conventional two and four-wire toll lines use manual ringing for signalling in both directions, or they have loudspeakers at the distant end for direct voice calling.
- o At the control center, they connect to the console loudspeakers for alerting or for passing messages directly to the controller.

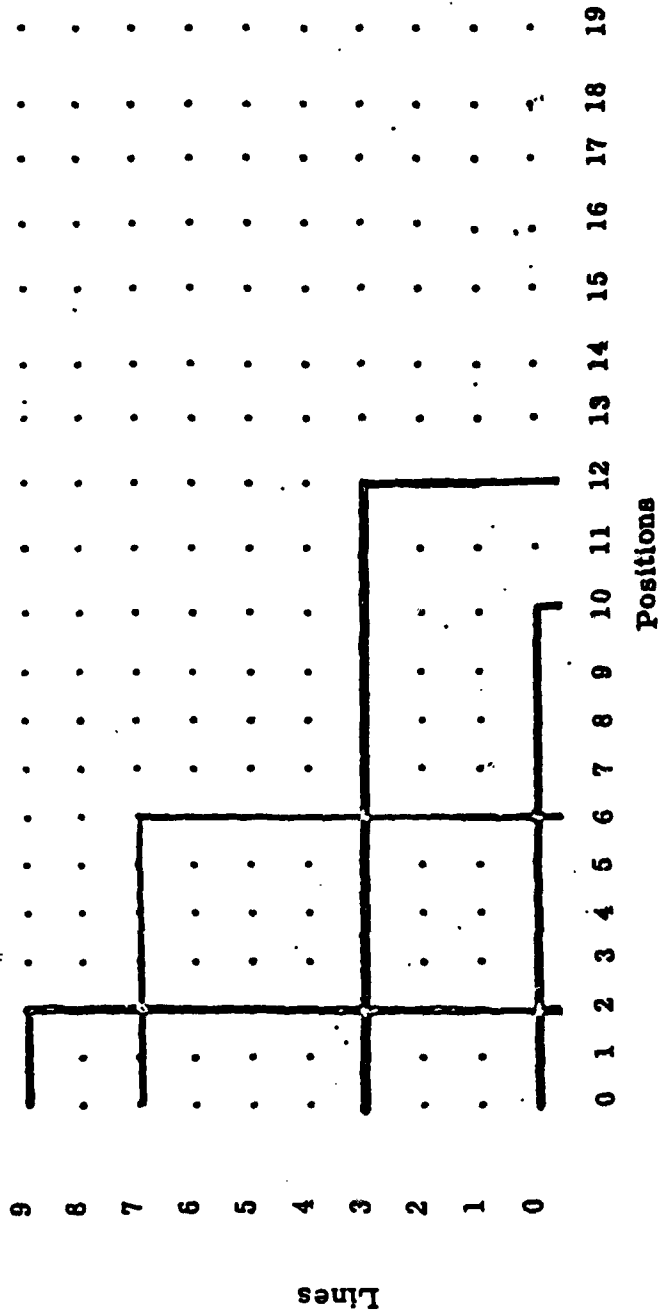

Coordinate Representation Crosspoints Matrix 10 x 20

Figure C-12

- o A voice-operated switch associated with a line allows incoming speech to actuate a locked-in flashing line lamp.

4. The Radio Circuits

The 300 SS initial design allowed a radio transfer feature to the controllers who have FAA switching equipment for connecting to air-ground radio transmitters and receivers [7]. The controller uses the same telephone set for radio as for telephone communication, but it is normally connected to his radio-control equipment until he operates a line key, the indirect access key, or common-answering key. By operating one of these keys, the telephone set is automatically transferred from radio to the 300 SS; when the line is released the system returns to the radio.

IV. WECO 301 SWITCHING SYSTEM

At the smaller FAA facilities, the workhorse of the FAA telephone switching network has been Western Electric Type 301A Key Telephone System (WECO designation J-53048) [1]. The system may be used in TRACONS, ATC towers, common IFR rooms, RAPCONS (Radar Approach Control), and small air traffic control centers. The system is a "Direct Access Type System", requiring a pick up key for each circuit appearing at each position [11]. Although this

electromechanical relay based system is designed to provide voice communication for a maximum of 42 control positions, facilities having more than 30 positions may find this system restrictive in operational flexibility as well as being economically expensive. Under certain conditions this system may be expanded beyond the normal 42 maximum position capability.

The Western Electric Company has recently developed a more efficiently packaged Modular Terminal Communications System (MTCS) to replace WECO key systems [9]. The MTCS will have the standard 301A features, and the electromechanical design, however, the equipment space requirements will be considerably reduced.

An enhancement of the original 301 Key Telephone System is known as 301A Key Telephone System.

A. Operational Features

1. Standard Features

The standard features incorporated in a WECO Type 301A Key Telephone system are basic to the requirements of all FAA communications. In addition to the standard features, the following are other features which are utilized to meet specific requirements at the individual FAA facilities [1], [10] and [11]:

- o Connects interphone and radio control equipment to controller's positions (non-locking type push button keys).

- o Terminates two and four-wire interphone lines (wire line, voice paging, emergency paging, override and radio access). An exception is the Automatic Voice Network (AUTOVON) lines which cannot be terminated in the system.
- o Interfaces with other telephone switching systems, (e.g., the 1A1, 6A, SS-1/A, 300, 301, 302 and 102A equipment).
- o Provides status lamp indications to display trunk status conditions.
- o Provides selective override, permitting a controller to override one or more other controller positions. Regardless of which position initiates an override, a two-way conversation is possible. If the overridden controller is using a wire line, a three-way conversation is possible. If either is using radio, the aircraft can hear only the controller who originated the radio connection. (This is basic FAA doctrine which all IC/IP systems must satisfy.)
- o Provides a variety of position equipment consisting of such items as headsets, handsets, microphones, key modules, rotary dial, speakers, buzzers and jack panels. Position loudspeakers receive wire and radio calls. Override calls can also be received in this LS when the HS/LS button is operated.
- o One set of recording leads is provided per position. TELCO supplied recorder connectors are required only when a "beep" tone is necessary as on business telephone line recording.
- o The system can be wired for simultaneous interphone/radio operation. This requires that preselected handoff and override circuits be equipped for hold-down operation. When a controller is using radio and then depresses a nonlocking line button, the radio is not released, thus permitting simultaneous operation. A maximum of four buttons may be held down without affecting transmission quality appreciably.
- o Voice activated status lamps. When an incoming voice call is received, this features causes the line status lamp to flash until the call is answered.

- o Extensions of business telephone lines may be terminated at the watch supervisor's positions for use during night hours.

2. Optional System Features

- o The coordinator override auxiliary indicator feature advises the coordinator that he is being overridden although he may be some distance from his position. It includes a "beehive" light and buzzer located at any appropriate place on the consoles. The light will flash while the regular override lamp at the coordinator's position burns steadily. The buzzer will sound for about two seconds after the position is overridden.
- o The coordinator monitoring feature provides the coordinator with the ability to monitor from one to five controller positions simultaneously and will not cause the override lamps to burn at the monitored positions. However, the override lamps will be activated by calls from other positions as usual.
- o LS/line cutoff feature deactivates certain lines from a position's LS by the prearranged use of one additional button for each line desired to be cut off at the position.
- o The emergency voice paging circuit between the tower cab and the radar room is terminated in one to four strategically located emergency paging LSs in each room and at nonlocking pickup buttons, normally at all positions.
- o Colored key buttons are available and may be used as desired locally to accentuate circuits or functions.
- o The continuous transmission feature permits preselected wire lines at specific positions to be arranged for "continuous transmission", i.e., the PTT button need not be depressed in order to transmit.
- o Single position monitor arrangement permitting a position to monitor one preselected position without lighting the override lamp at that position and without supplying microphone current to the position or any noise in the overridden position earpiece.

The recently introduced Modular Terminal Communication System (MTCS) version of WECO 300 Key Telephone System includes the following standard 301A features:

- o 12 to 36 PB key units
- o Electrically locking or "hold-down" line pickup
- o Override and/or intercom
- o 2W and 4W interphone circuits
- o Automatic/manual radio access
- o Single channel position recording
- o Jack preemption
- o Variable backlighting
- o Position monitoring

In addition, the new MTC features not included in the old version of 301A are:

- o Receiver amplifier arrangement to:
 - limit tones into headset
 - prevent recording of speech pickup from HS receiver
- o Recording of controller briefing
- o Tone ringing
- o Standard transmission levels to FAA:
 - radio
 - recording

B. Equipment Description

The WECO 301 Key Telephone System is basically designed for the medium sized FAA air traffic control facilities, e.g., ATCT or TRACON. The circuits connecting into the ATCT and ATCT/TRACON facilities are shown in Figures C-13 and C-14 [1]. These figures exemplify the communication connectivity; the functions of links terminated at 301 systems and the end terminal facilities. This system consists of position equipment and key telephone system backroom equipment.

The landlines used for providing connectivity are leased TELCO circuits. The following four types of landline circuits are interfaced:

- o Override line circuits between attendant positions within this system, between one or more positions external to this system and one within this system, and between one or more positions within this system and one external to this system.
- o 2-wire line circuits with automatic loop, manual ring or voice signalling to other systems, station sets or a CO or PBX. A "beep" tone will indicate recording.
- o A 2-wire dial intercom line circuit.
- o 4-wire voice paging line circuits and selective signalling line circuits with send only capability or with two-way dial capability.

1. Position Equipment

The position equipment of the Modular Terminal Communications

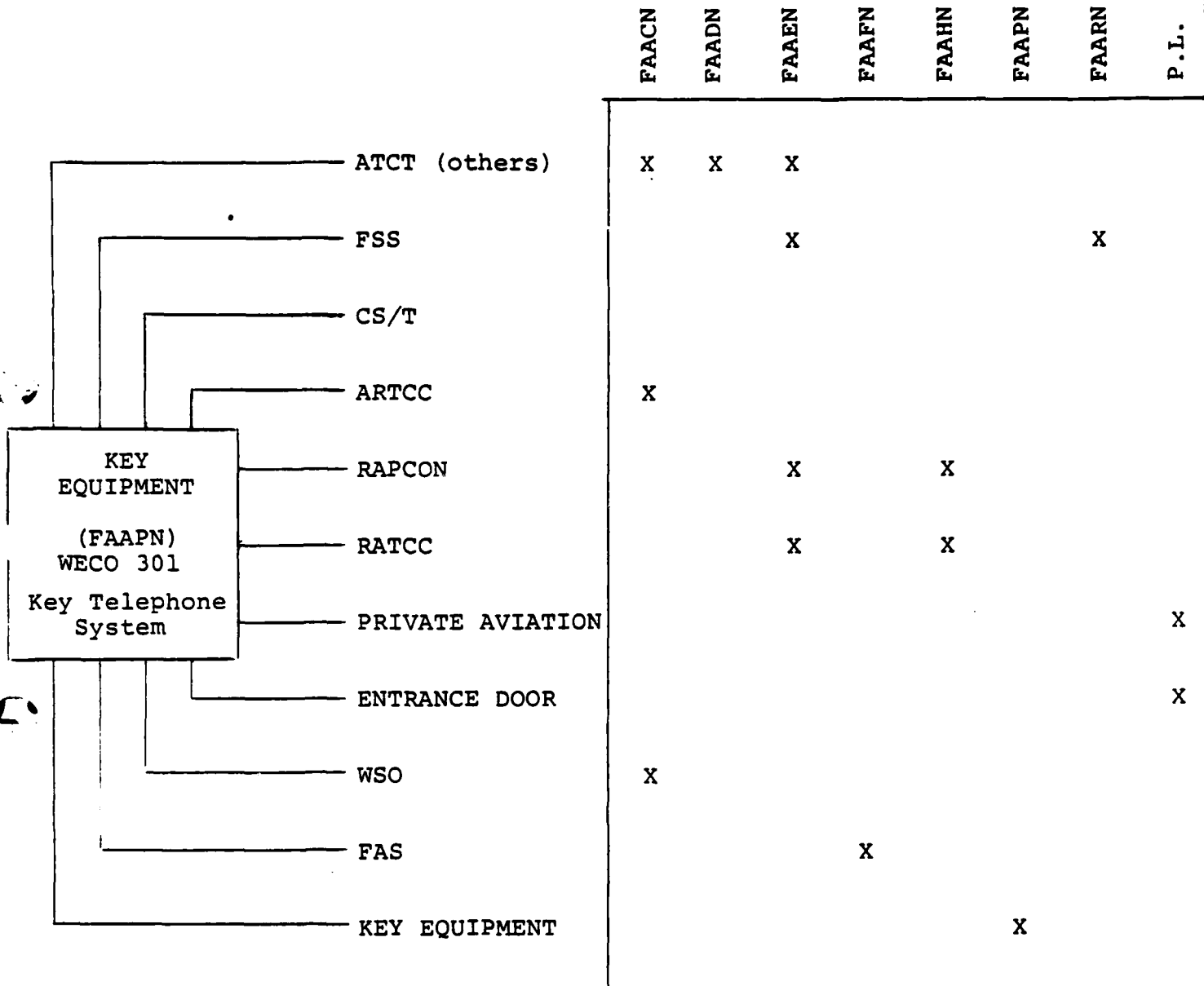

REPRESENTATIVE TERMINATIONS BY CIRCUIT TYPE TO/FROM ATCT

Figure C-13

| | | Circuit Type | | | | | | | | | | |
|--|----------------------|------------------------------|-------|-------|-------|-------|-------|-------|-------|-------|-----|---|
| | | FAAAN | FAABN | FAACN | FAADN | FAAEN | FAAGN | FAAHN | FAAPN | FAARN | MIL | |
| | | <u>End Terminal Facility</u> | | | | | | | | | | |
| <p>WECO 301 KEY TELEPHONE SYSTEM EQUIPMENT (FAAPN)</p> | ATCT/TRACON (others) | X | | X | X | X | | X | | X | | |
| | ARTCC | | | X | X | | | | | | | |
| | ATCT | | | X | X | | | | | | | |
| | FSS | | | X | | | | | | | | |
| | CS/T | | | X | | | X | | | | | X |
| | RAPCON | | | X | X | X | X | X | | | | X |
| | RATCC | | | X | X | X | X | X | | | | X |
| | FAA-SCC (CARF) | X | | | | | | | | | | |
| | ANG | | | X | | | | | | | | |
| | BASOPS | | | X | X | | | | | | | |
| | WSO | | | X | | | | | | | | |
| | AIRLINES | | | X | | | | | | | | X |
| | FIREHOUSE | | | | | | | | | | | X |
| | FRONT DOOR | | | | | | | | | | | X |
| | UAS (PBX) | | | | | | | | | | | |
| GCA | | | | | | | | | | X | | |

REPRESENTATIVE TERMINATIONS BY CIRCUIT
TYPE TO/FROM ATCT/TRACON

Figure C-14

System is the latest version of the WECO 301 Key Telephone System. The components of the position equipment are:

- o A Pushbutton (PC) key unit, connector-ended and flush-mounted in the FAA ATC position console.
- o A set of six electrically-locking common function push-buttons with the following functions:
 - Release disconnects the position instrument jacks from an established landline connection, (except an incoming override connection), connects the jacks to the radio interface circuit, (if the automatic radio feature is provided) - connects the incoming voice signals, (except override), to the position loudspeaker.
 - Manual radio (optional) - connects the position instrument jacks to the radio interface circuit and releases any selected landline (the status lamp on the PB flutters when this feature is selected).
 - Flash/ring - when operated, provides a manually controlled ringing on a ringdown line or takes the place of a switchhook for flashing recall of a distant operator. The status lamp associated with this push-button will be lit steadily when an incoming override call is connected to the position.
 - Hold (optional) - when momentarily operated, establishes a "hold" condition on an established CO or PBX connection.
 - Spare - may be used for miscellaneous purposes such as to control a customer-provided door opening mechanism.
- o Twelve electrically-locking line selection pushbuttons for attendant connection of 2-wire and 4-wire landlines:
 - only one line may be connected to a position at a time,
 - selection of another landline releases any previously selected landline,
 - selection of any landline transfers the radio receive circuit to the loudspeaker position.

- o Two sets of connector-ended instrument jacks for use with either headset, handset or hand microphone:
 - a green set labeled "CONT", normally used by the controller;
 - a yellow set labeled "INST", normally used by an instructor.

- o The receiver transfer or "LS" switch is a turn button on the jack assembly panel. It transfers the total receiving capability of a position from the telephone instrument to the LS regardless of the circuits selected. The talking portion of the circuit remains in operation through the jacks. A handheld microphone should be used for this operation.

- o The following visual signals are displayed on push-buttons to indicate line status or feature status:
 - Off (dim, when back lit)
 - line still available
 - feature still available
 - Steadily lit (bright)
 - line selected by another position
 - the feature has been selected at this position
 - Flash (50 IPM, 50/50 on-off ratio)
 - an unanswered call
 - Flutter (720 IPM, 80/20 on-off ratio)
 - selection of a line at this position
 - Wink (120 IPM, 47/3 on-off ratio)
 - a CO or PBX line in a "HOLD" condition

- o A loudspeaker for receiving incoming voice calls (override, interphone and radio):
 - equipped with
 - automatic gain control
 - an ON/OFF switch with visual indicator
 - an external volume control

- o A loudspeaker mixer circuit - permits simultaneous reception of up to ten incoming voice calls in the position loudspeaker,
 - provides a minimum of 60 dB isolation between voice lines.
- o Sidetone circuit - permits the attendant to hear his voice transmission at a normal receive level in his instrument receiver.
 - inhibits sidetone from being heard in the loudspeaker.
- o Push-to-talk switch on the telephone instrument,
 - originates voice transmission
 - inhibits transmission to an overriding position when connected to a radio interface circuit.
- o Position recording interface - permits recording on an FAA recorder via a single channel, of all voice transmissions to and from the position instrument jacks and to the position loudspeaker.
 - provides a separate recording channel with split position capability for recording all transmission to and from the controller connected to the radio interface circuit.
- o Incoming voice signalling,
 - announced over the loudspeakers of positions associated with a voice calling line.
 - a voice-operated lamp flashes to indicate the incoming call at the pushbuttons associated with that line.
 - inhibits incoming voice from all associated position loudspeakers when that line is selected by an attendant.
- o Instrument disconnect arrangement,
 - activates when all telephone instruments are removed from position jacks.

- eliminates line selection or answering ability at the position and releases any connected circuits.
- transfers incoming radio and override calls to the position loudspeaker.
- retains incoming override and individual line status lamp indications and buzzer operation at the position.

The following items are available as options on the position equipment [9]:

- o Two types of key modules (Key Module #635, #652).
- o Direct access (DA) to initiate or answer a call (not an incoming override call).
- o A key for each outgoing override circuit terminated at a position.
- o A pick-up key is used to initiate or answer an emergency voice page call.
- o The Radio Key (RDO key) allows radio calls to be received at the headset or handset at a position having radio/interphone capability.
- o Buzzer and Buzzer Cutoff key
 - The buzzer shall be energized on calls directed to the position which causes the position pilot lamp to operate.
 - Successive operation of the buzzer cutoff key alternately causes the buzzer to be operated or silenced on incoming calls. The status lamp associated with this key is energized when the key silences the buzzer.
- o The Speaker Cutoff key is provided per position for each voice call circuit with the "Speaker Cutoff" feature.
- o Voice Actuated Status lamps flash when an incoming voice call is received at the position until the call is answered.

- Coordinator Override Auxiliary Indicator lamp flashes on override calls only. The feature consists of both a lamp and buzzer (separate from the position normal buzzer).
- Monitor "MON" key is a special key used for the coordinator monitoring feature (optional), which provides a monitor capability for up to five other positions simultaneously with a level drop not to exceed 3 dB.
- Simultaneous Interphone/Radio for positions having a radio capability, is activated when the position "RDO Key" is depressed to transfer the position instrument to radio. Up to four circuits may be selected for simultaneous conversation with radio.
- Automatic PTT (also called the "Continuous Transmission" feature) is energized when the pick up key is operated and incoming calls are received over SS-1 Type 4 or 5 circuits. (Energizing the PTT is a universal option for all circuits.)
- Attendant telephone instruments include:
 - Headset equipped with a push-to-talk switch, having both a mechanically locking and a non-locking position, and a retractile 6-wire plug-ended cord.
 - Handset equipped with a non-locking push-to-talk switch and a retractile 6-wire plug-end cord.
 - Hand microphone equipped with a non-locking push-to-talk switch in the microphone housing and a retractile 4-wire plug-ended cord; used in conjunction with the position loudspeaker when the receiver transfer key is operated.
- Footswitch (push-to-talk capability) is plug-ended in a jack and is in parallel with the PTT switch of the position instrument.
- Plug-ended rotary dial is used to dial on CO, PBX, intercom or 4-wire selective signalling lines.
- Trainee jack preemption (by operation of the PTT switch), allows voice preemption by instructor when the trainee is overridden while connected to radio.

- o Pushbutton key units provide direct access selection of up to 24 lines or control functions at the position (in addition to common function pushbuttonoms).
- o The Automatic Instrument Jack connection to a radio interface circuit is automatically made when no landlines are selected at a position. When a landline is selected at the position, the radio is automatically released from the jacks and the radio receive is connected to the position loudspeaker.
- o The Manual Instrument Jack connection is a pushbutton connection of the position instrument jacks to the radio interface circuit when the manual radio pushbutton is operated and released of any selected landline. Selection of any landline will release the radio connection from the position instrument jacks and reconnect the radio receiver to the position loudspeaker. During this manual radio connection to the jacks, incoming override calls will also be connected to the instrument jacks.
- o Split Position Operation is when one attendant utilizes a telephone instrument plugged into the "INST" jacks connecting only to the radio interface circuit, and another attendant plugs the telephone instrument into the "CONT" jacks connecting to a selected landline and to override calls incoming to the position.

The trainee jack preemption capability, if provided at the position, will be disabled.

- o A variable backlighting arrangement is an attendant operated control for varying the intensity of the dial/pushbutton and status signal pushbutton intensity as the ambient lighting changes.
- o Manual disconnect of voice signalling lines when operating a PB (provided one per line), will cut off incoming signals on a particular line from a position's loudspeaker and disable all lamp signals at the line selection pushbutton for that line.
- o To indicate an unanswered incoming landline call, either a common buzzer or a buzzer per position is supplied.

- o Telephone console (Call Director) - The Watch Supervisor position is provided with a Western Electric Type 50A1-60 (grey color) or 60A1-61 (beige color) telephone console (or equivalent), which is desk top mounted or panel flush mounted. As alternates to the 30 key console, a 50 key flush mounted telephone console could be used. Either of these consoles will be usable for other supervisor positions within the system (such as the supervisor position in the tower cab).

2. Backroom Equipment

The 301 System is controlled and switched by the backroom equipment which also provides interfaces to all lines to positions as well as various TELCO and other trunks. It includes power supplies and distribution frames.

A 301 Key Telephone System block diagram is shown in Figure C-15, simplified to show its basic functions. The interface points on the TELCO network are shown in Figure C-16. A compact Modular Terminal Communications System (MTCS) has been developed which replaces the WECO 301A systems [9].

The basic dimensions of the equipment racks accommodating a 301 system are:

- o Space, Height: 6'10" (minimum ceiling 7-1/2 ft.)
 - Width: 2 feet
 - Depth: 1-1/2 feet
 - Weight: 300 lbs.
- o The operational environment for the 301 system is defined at:
 - Temperature: 40° to 100° F.
 - Relative humidity: 5% to 90%

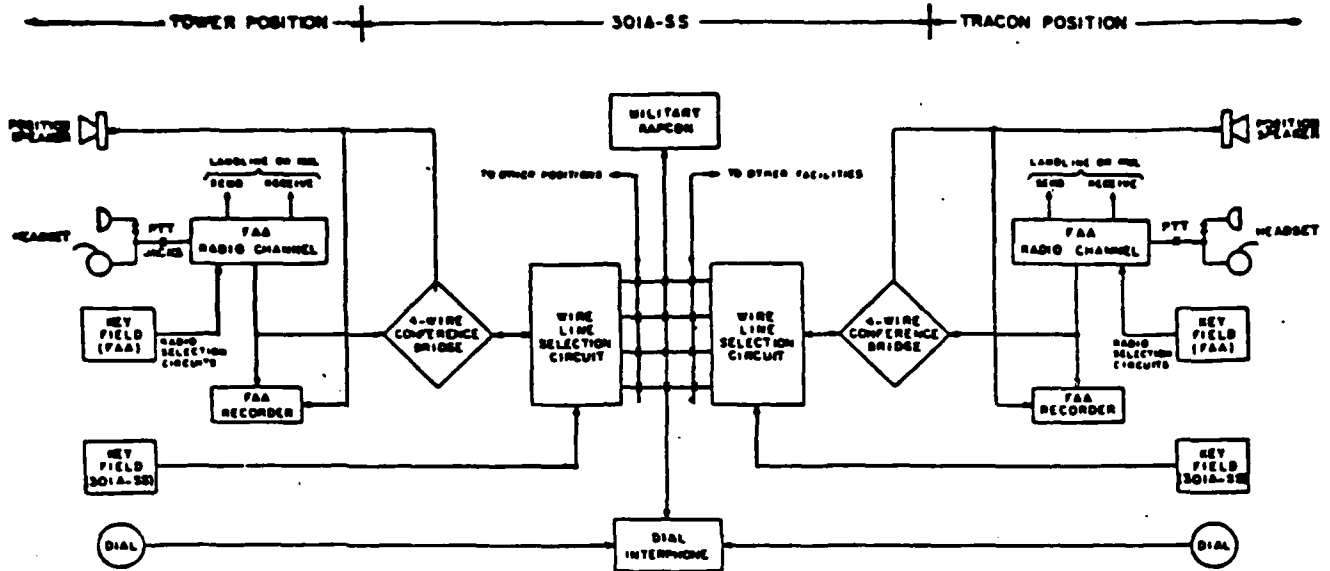

TELCO TYPE 301 SWITCHING SYSTEM, SIMPLIFIED BLOCK DIAGRAM

Figure C-15

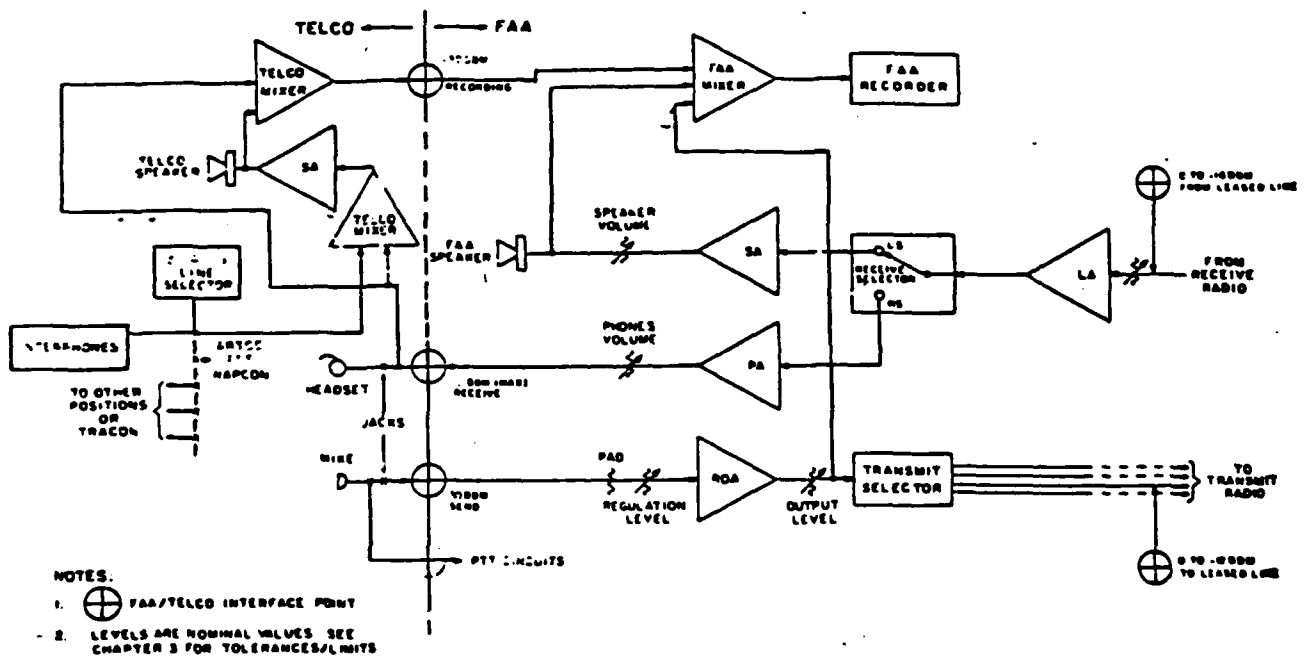

FAA TO TELCO INTERFACE POINTS, 301 SS

Figure C-16

- o The primary power supply requirements are:
 - Voltage: -24V; current approximately 2-1/2 amperes per position.
- o Emergency backup power is provided to last up to eight hours.

The latest MTC version of the WECO 301 system interfaces with the TELCO equipment at 2 levels.

- o The radio interface with FAA radio control equipment will include a push-to-talk function. A dry contact closure, capable of handling a 250 milliamperere lead, will operate within 15 milliseconds of the operation of the position telephone instrument PTT switch.
- o The transmit and receive audio levels at both the FAA and the Bell System interfaces will be in accordance with standard Bell System practices.

The types of circuits interfaced are:

- o Circuit No. 1 - Override, includes three options:
 - Normal override
 - Remote override
 - Multiple override.
- o Circuit No. 2 - Local Coordinator ("C" circuit).
- o Circuit No. 3 - Non Selective (private line circuit).
- o Circuits No. 4 and No. 5 - Selective Signalling (works on SS-1 signalling).
- o Circuit No. 6 - C.O.E. or PBX Extension (for connections to remote stations).
- o Circuit No. 7 - PBX Tie Line (not presently employed)

- o Circuit No. 8 - Local Dial Line (for communication to/from local C.O. subscribers).
- o Circuit No. 9 - Voice Page ("hot line").
- o Circuit No. 10 - Remote Coordinator (used between distant ATC facilities).

V. WESCOM 920 KEY SYSTEM

A limited number of WESCOM Key Systems have been employed by the FAA, primarily in smaller facilities served by GTE operating companies [12]. These systems are designed as interphone key systems for small air traffic control towers and provide an interface for radio control. A functional block diagram of a WESCOM 920 installation is shown in Figure C-17.

A. Operational Features

The WESCOM 920 is a modular unit which provides the following basic features [8]:

- o Position consoles for selection of interphone or radio control equipment. Available in sizes of 12, 18 or 30 lines, with speakers. Equipped with plug-ended cables for ease of installation.
- o Connections to:
 - A variety of lines
 - Standard telephone equipment and facilities
 - Switching Systems (301A, 300, 1A2, 6A, SS-1A)
 - Cable and carrier systems.

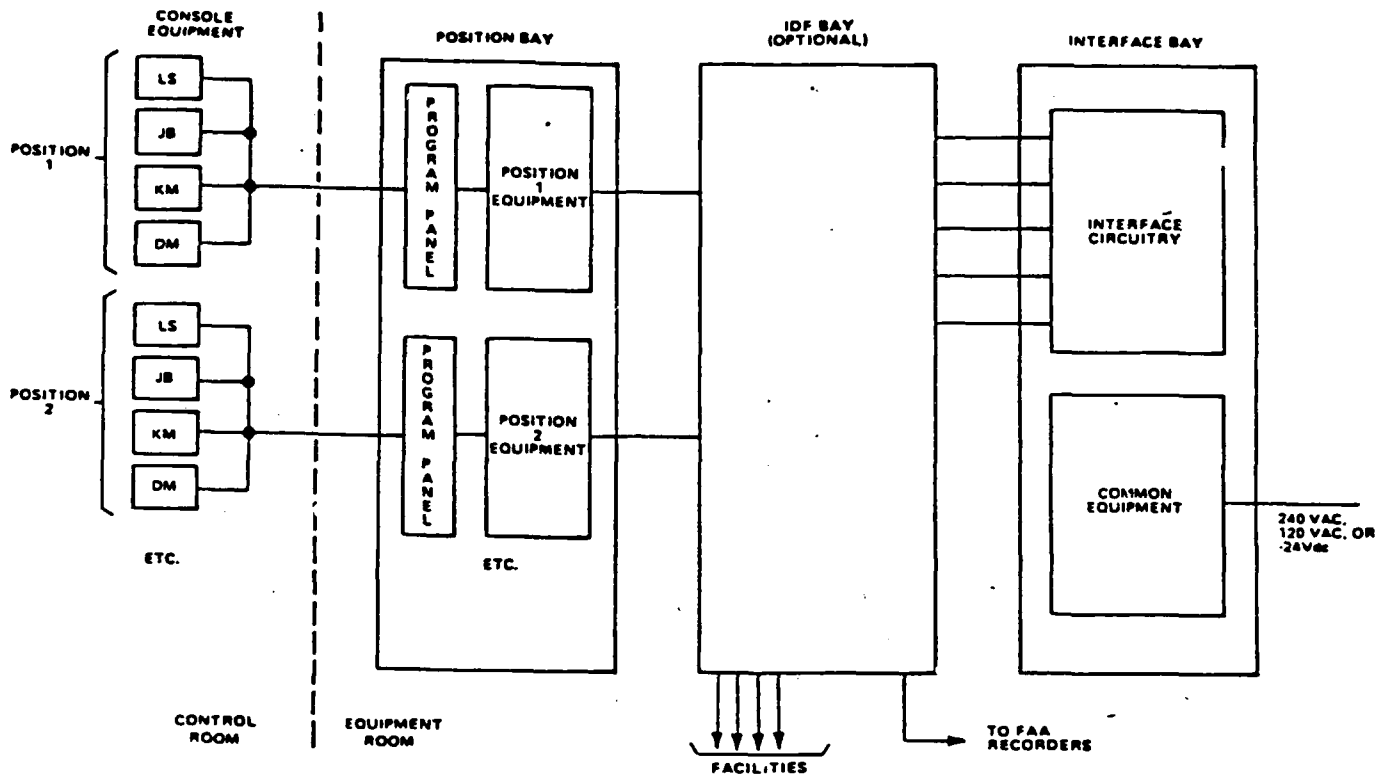

FUNCTIONAL BLOCK DIAGRAM OF A WESCOM 920 INSTALLATION

Figure C-17

- o Compatability with Type 3 through Type 9 trunk circuits.
- o Connections for recording devices (voice data connection).
- o Termination of 2 and 4-wire lines of various types.
- o A system intercom allows intra-communication between operators.
- o Preemption feature (optional) at each position. An instructor can preempt control of voice transmission.
- o Audible signalling (optional) provides a tone ringer which is energized on all incoming calls except radio and voice page circuits. Tone ringing ceases when the circuit is picked up by a position.
- o The Push-to-Talk (PTT) feature provides the customer with one set of closed contacts when the PTT switch associated with the position instrument is operated. The PTT switch must be closed to transmit voice from the position. The time interval from activating the PTT switch to the appearance of the closure at the demarcation strip is less than 25 ms. The switch contacts will accommodate a maximum load in excess of 250 ma.

B. Equipment Description

The WESCOM 920 is a relay based key system used by the FAA in small facilities where air traffic controllers are allowed to access lines to radio equipment, other controller positions, remote locations at the same FAA site, distant FAA facilities, and the commercial telephone network [12]. The system block diagram is shown in Figure C-18. The system capacity is a minimum of two and a maximum of ten positions, and can accommodate from 1 to 30 lines. The system includes Position Consoles and backroom (contact/interface) equipment which allows interface with a variety of lines, equipment, facilities and switching systems (viz: 300, 301A, 1A1, 1A2, SS-1A,

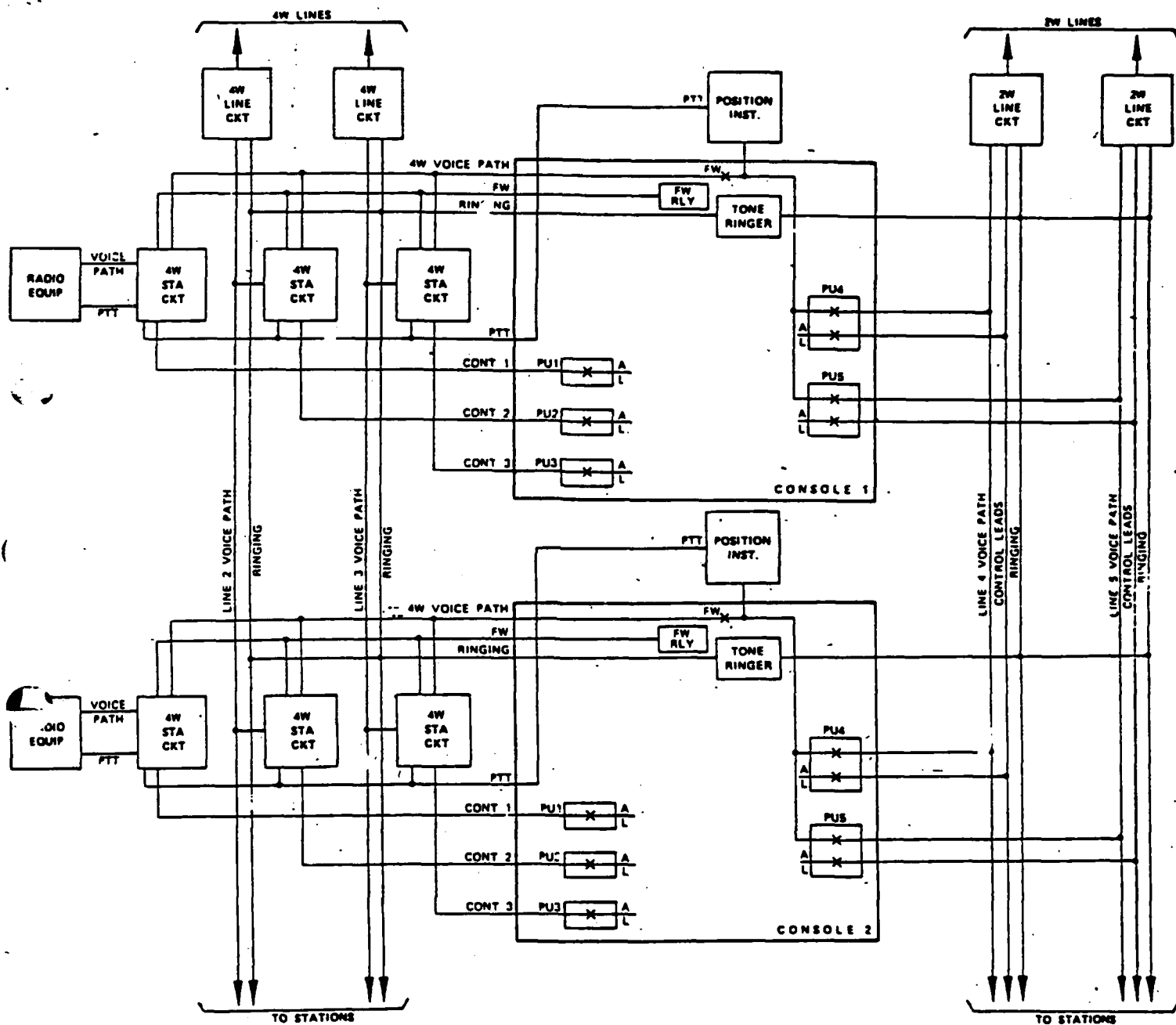

WESCOM 920 MODULAR TOWER PACKAGE SYSTEM, BLOCK DIAGRAM

Figure C-18

etc.) [8]. Features of this system are:

- o Visual and Audible Signaling: The WESCOM 920 system incorporates a number of visual and audible indications, which aid the controller in identifying the status of lines and other events.
- o Status lamp visual indications - internal line status lamps provide the indications shown below for each of the pickup keys. There are no status lamp indications for the HOLD, RING, FLASH or RELEASE keys. All other keys have status lamp indication.

| <u>Lamp Condition</u> | <u>Status Indicated</u> |
|-----------------------|--|
| Off or Dim | Line is idle; no position connected |
| Steady On | Busy; connection has been made by any position to that circuit |
| Flashing | Incoming calls being received; no position connected |
| Winking | PBX or CO circuit placed in a hold condition. |

Note: DIM - Minimum backlighting

FLASHING - 60 impulses per minute (IPM),
50/50 on-off ratio

WINKING - 120 IPM, 47/3 on-off ratio

Four broad categories of lines/trunks are terminated at the system, the interface requirements are:

- o Commercial (TELCO) - two-wire central office of PBX lines are accessed through a 2-wire line card. This card converts the incoming 20Hz signalling to flashing lamp voltage for the appropriate line key(s) and the 20 Hz interrupted tone ringing or the ground as required for the consoles. The 2-wire card also provides the hold function and controls the wink function of the line status lamps.

- o Radio Access - A radio access circuit consists of 4-wire line and a 2-wire PTT control circuit. The 4-wire line provides the transmit and receive paths between the radio equipment and the interphone key system. The transmit level is adjustable to provide the necessary (nominally 0 dBm) at the demarcation strip. The receive level is also adjustable to provide the necessary level at the position speaker and instrument. When the PTT switch is closed, the 2-wire radio control line provides a contact closure to key the radio transmitter.
- o Local Site - Local site communications include the interposition and the controller position to the on-site remote location communications. Interposition communications can be provided by the following three circuits:
 - a dial intercom
 - an interposition ARD line
 - a 4-wire voice intercom.

This dial intercom can be configured as a single-digit system or as a double-digit double-link system.

- o Intersite - The most common intersite communications (besides commercial TELCO lines) is by means of the SS-1A capability which is provided in the WESCOM 920 package. The signalling and coding systems are compatible with the WECO SS-1A system. The SS-1A systems may send only, receive only, or send and receive, depending on the site requirements.

1. Position Equipment

The WESCOM 920 multi-line type console shown in the Figure C-19, consists of a number of pushbuttons and other devices [12], e.g.,

- o Set of 12/18/30 keys
- o Dial or DTMF key pads
- o Push-to-talk switch for transmitter control

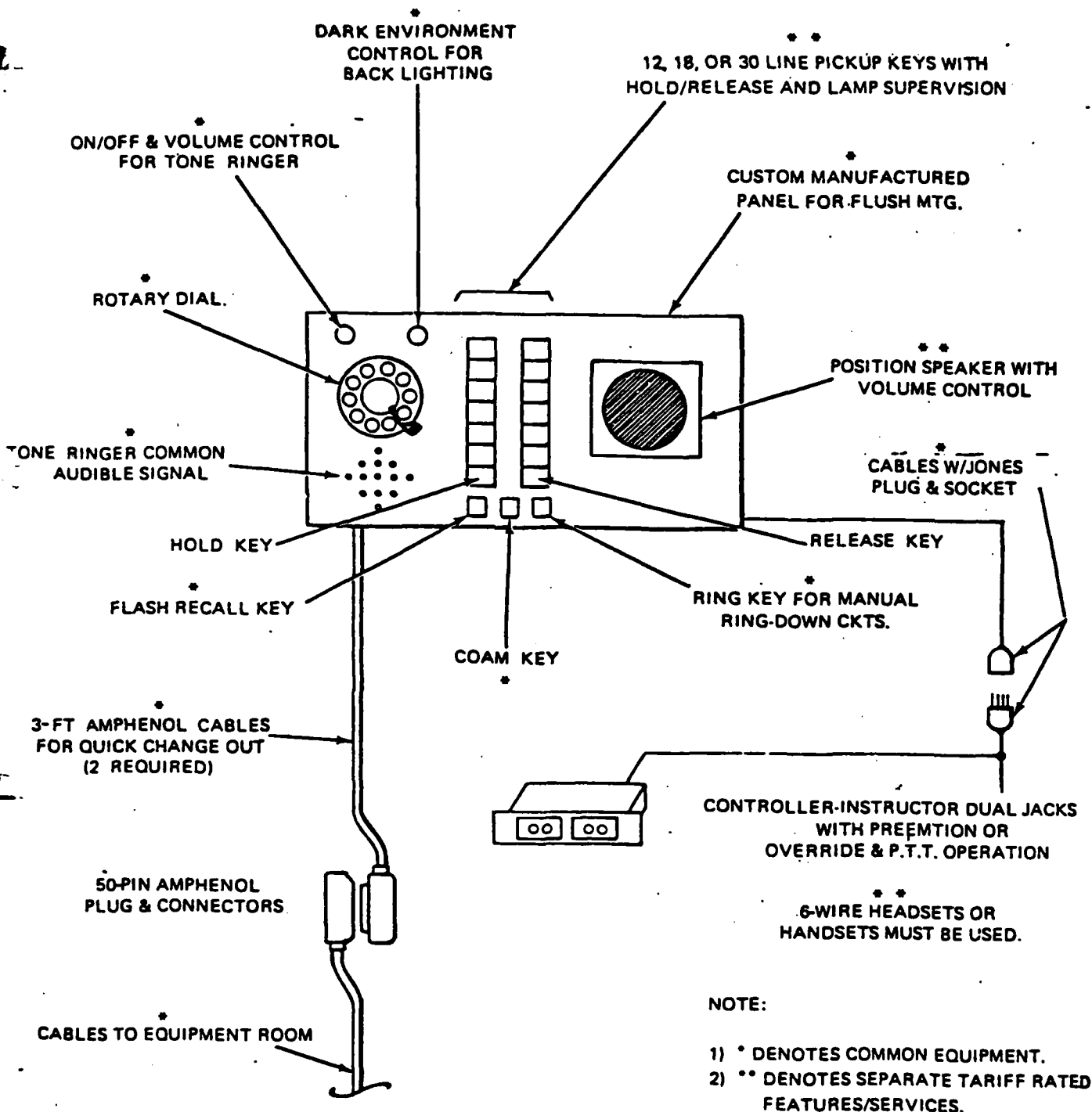

WESCOM 920 12-LINE CONSOLE LAYOUT

Figure C-19

- o Common key functions:
 - The REALEASE key to release the selected circuit at the termination of a call.
 - A RING key for manual ringdown circuits.
 - A FLASH key to momentarily break the 2W loop.
 - A HOLD key to provide circuit hold functions.
 - A COAM key with a ground output for any function desired (if not designated for door control).
- o Lamp indications for line status
- o A variable backlighting control on each console, to adjust the level to suit the ambient lighting conditions
- o Tone ringer call arrival indication
- o Handset/headset with push-to talk button
- o Loudspeakers (receive/terminate incoming voice signal/calls)
- o Off/volume control on low limit volume control on lous-speaker (optional)
- o Plug-ended cables for connection to relay rack equipment
- o The level adjustment equipment provides a connection to other interphone and radio lines at transmit and receive levels standard in the telephone industry.

The Console Operation. To select a line, the appropriate mechanically-locking line is depressed by the controller. Only one key may be locked at a time. To release the line there are three alternatives:

- o By depressing another line key,
- o By operating the RELEASE key, or

- o By removing the position instrument plug from the jack box.

2. Back Room Equipment

The WESCOM 920 system backroom equipment consists of a 19 or 23-inch relay rack which is provided to mount the circuit modules and common equipment [12] . The WESCOM Type 400 shelf is used to house the equipment as shown in Figure C-20. A broad range of modules for supplemental services are available for this mounting assembly. Included with the common equipment is a -24VDC power supply (normally 115VAC input), fusing, ringing generator and ballast lamps. A wire-wrapped strapping field shown in Figure C-21, is provided at the top of the relay rack to facilitate factory and site wiring. All assignments of lines to line circuits and stations to lines are done on the strapping field.

VI. SMALL KEY STSTEMS

The Key Telephone Systems (KTS) are meant for the Flight Service Stations and the smaller towers. The standard WECO types are 1A, 1A1, 1A2 and special assemblies assembled to meet specific requirements of the FAA.

The three FAA facilities where these smaller units are used are:

- o Air Traffic Control Towers (ATCT)

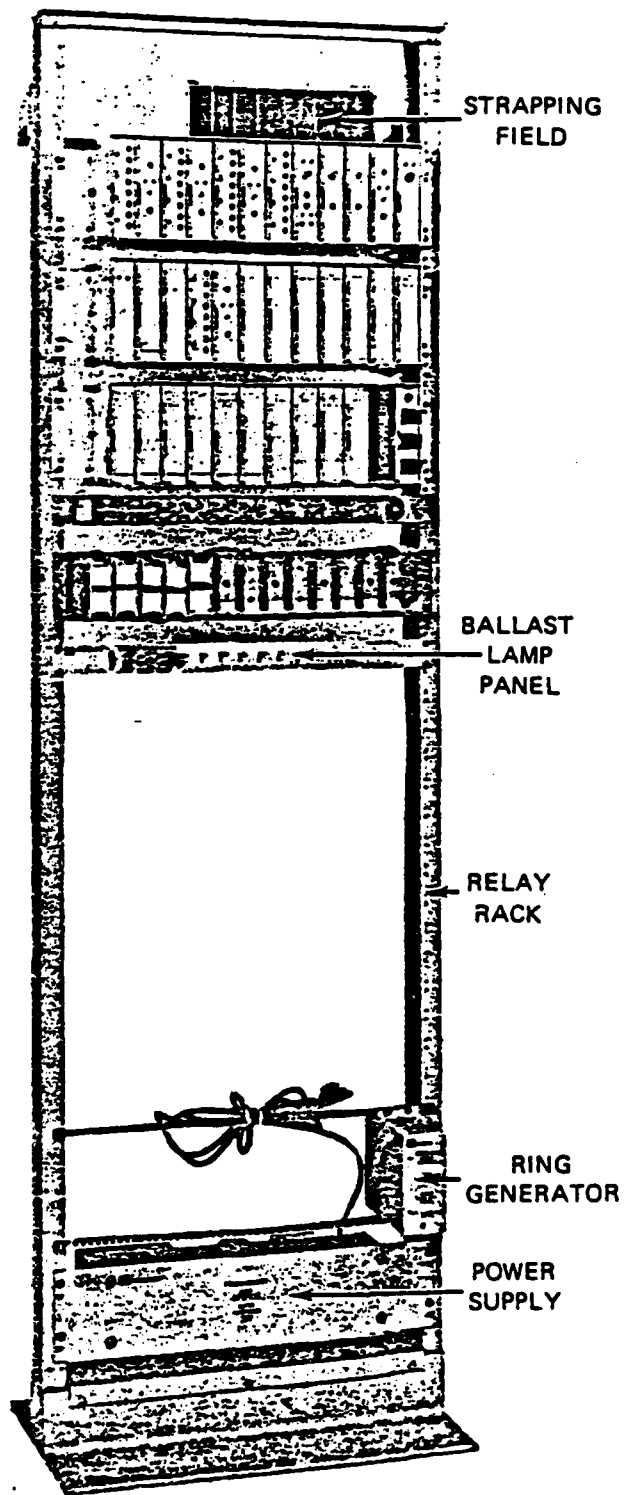

WESCOM 920 BACKROOM EQUIPMENT

Figure C-20

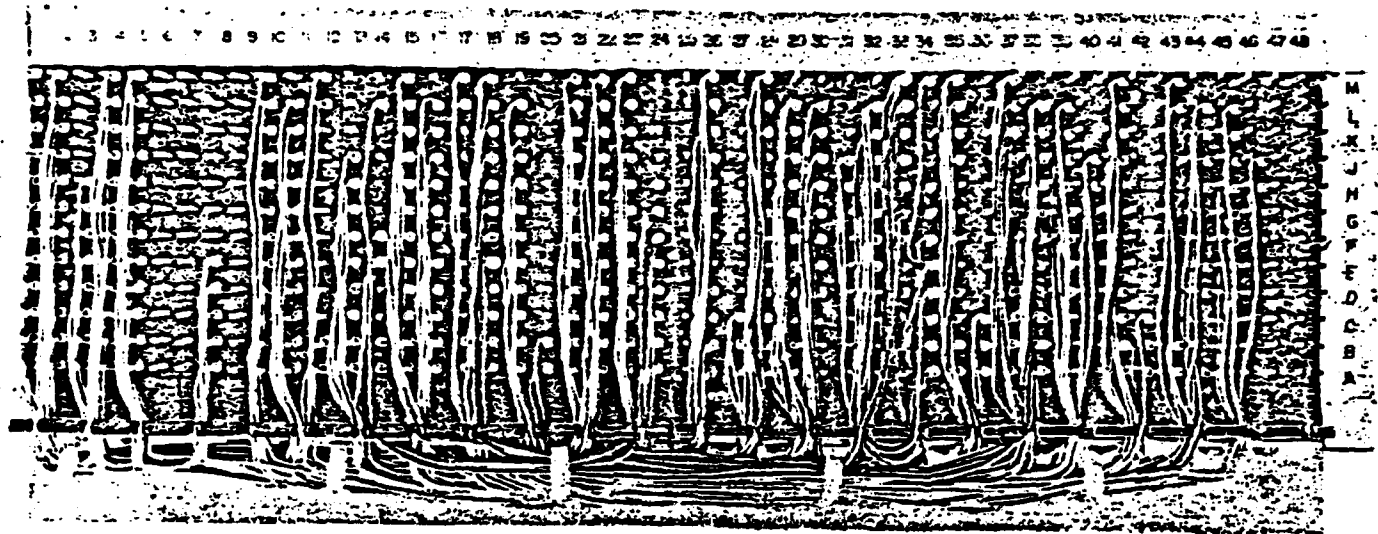

WESCOM 920 STRAPPING FIELD

Figure C-21

- o Control Tower and IFR Room (ATCT/TRACON)
- o Combined Station/Tower (CS/T)

When a facility outgrows a Key Telephone System (KTS) it becomes a candidate for an Automatic Call Director (ACD).

The 1A1 key equipment is the most common "backroom" equipment used for terminating the voice circuits. It is used at the relatively small (in terms of circuit usage) facilities. A number of other types of small special key equipment are used at operating positions in various facilities, as shown in Table C.3 1 . Each module, although electrically consistent with many others, is physically constructed with a number of variations. Each variation is assigned an individual number.

A. Operational Features

- o The 1A Key Telephone System

This unit serving aviation controllers performs limited switching functions, e.g.,

- Holding on CO/PBX Lines
- Providing Visual Line Signals
- Intercommunication Switching
- Cut-off, exclusion and selective privacy
- Private line

A few options are available e.g., Visual/Audible Signals, intercommunicating facilities, automatic time-out, etc.

o The 1A1 Key Telephone System

In addition to the basic features and functions provided by 1A Key Telephone System, the 1A1 Key Telephone includes audio and visual indication of incoming signals by steady/intermittent signals.

o The 1A2 Key Telephone System

In addition to the features provided by the 1A1 system, the 1A2 KTS line circuits are arranged for time-out of the locked-in visual/audible signals on a per line basis. Other features are; pick up and hold on CO or PBX lines, visual signaling, audible signaling, power failure transfer, intercommunications, exclusion, tie lines, add-on conferencing, station busy lamp, long line capability, supplementary hold.

B. Equipment Description

o The 1A Key Telephone System is a small capacity, simple key telephone system, compared to the 1A1 and 1A2 system. The Line Circuit includes relays which operate and latch on the line battery. To provide the Hold feature, Transmit/Receive pairs and a hold lead is required.

o The 1A1 Key Telephone System may constitute a WECO multi-pushbutton Set Call Director, or a separately mounted multi-button key on KTU or a package called the Key Service Unit (KSU). These are units which provide the switching and control function contained in the apparatus boxes or the equipment cabinets.

Outside lines (FAS, FX or local telephone) are terminated at the key sets, and in some high-volume operations through a call allotter. The call allotter assigns waiting calls to the first available operator on a first come - first served basis.

The 1A1 system may be terminated by a 6-button or a 12 or 18-key keyset or a 6-, 12- or 18-key call director at each specialists position. (this configuration also applies to 1A2 system).

o 1A2 Key Telephone System consists of:

- KTS or non-key set
- 400 Series KTU switching and control feature

- KSU Panels
- Local power for talking, audible, signal, lamp/relays operation, etc.

VII. CALL DISTRIBUTION UNITS

A Call Distributor Unit distributes incoming calls at a Flight Service Station (FSS) to the attendants. The distributors are connected to a number of local loops (station lines) from a local exchange and to the Foreign Exchange (FX) lines and WATS lines. These lines terminate the calling pilots and the public (over the TELCO network) who wish to reach the FSS specialists. The following types of Call Distributors are commonly utilized in the FAA facilities [13] .

- o WECO 2B automatic (large capacity).
- o WECO 4A non-automatic (small capacity).
- o WESCOM 928 ACD
- o WECO ESS-ACD (being developed).

The Call Distributor units are versatile and include a number of features not generally applicable in the FAA network. There are some modifications done by the local TELCOs to adapt these to FAA requirements. Other modifications to the original equipment have made it possible to accommodate greater capacity in smaller space and to include the new control features for more

efficient administration and reduced installation cost.

A. Operational Features

The larger FSS facilities employ one of the three call distribution units which include the following basic features:

- o Include 18 or 30 pushbutton sets
- o interface capability over 2- or 4-wire circuits
- o Standard signaling e.g., SS-1, ringdown, automatic and voice signalling
- o a hold feature for central office lines
- o single lamp operation (flash, steady, wink)
- o locking buttons, switch hook
- o single jack operation
- o dial selective local intercom termination.

Options include:

- o loudspeaker monitoring
- o common signal key

In addition to the basic features, the Automatic Call Distributor (ACD) unit WECO 2A includes the following additional operational features:

- o Distributes the incoming calls in order of arrival
- o Transfers the calls to the other positions or to the supervisor
- o Supervisor's position control of the attendant positions
- o Means for the attendants to consult the supervisor

- o Sends the delay announcements to callers not answered immediately
- o Display of the incoming trunk status
- o Rotary dial calling (pushbutton capability)
- o Interface with radio and landlines to allow the radio operator to help the ACD attendants
- o 6-Wire Jacks

(NOTE: The WESCOM 928 ACD unit has similar features.)

A WECO 4A call distributor includes the operational features listed:

- o Incoming trunks at all attendant positions and at supervisors position
- o Incoming calls are identified on a first-come first-served basis on a lamp display
- o A recorded announcement is sent to all calls which cannot be answered immediately
- o Rotary Dial provided (Pushbutton capability)
- o Handset or headset is provided
- o Service observation capability to attendant positions.
- o Supervisors' capability to enter conversations handled by attendants
- o The transfer of calls from one attendant position to the other takes place by verbal indication and depressing the appropriate pushbutton for the incoming trunk.

B. Equipment Description

The call distributor units interface with the FAA communications systems exchanges at the towers, TRACONS, ATRCCs, other

FSS units, and with the local TELCO telephone network. The transmission facilities terminated at these switching elements include the IC/IP network, FTS, DDD, Foreign Exchange (FX) lines, Local Exchange (LX) lines, Local PBX trunks, and the WATS lines.

The telephone system which a flight service station utilizes varies from location to location. The telephone system includes one or two private number lines to a local exchange in the smaller FSS, local exchange numbers on a ringdown, several foreign exchange numbers; private on-base circuits, and GP circuits for the larger stations. The smaller FAA facilities utilize a six-button desk set with two or three local exchange numbers. The larger facilities use call distributors e.g., Western Electric (WECO) 2B ACD, WECO 4A ACD, or the WESCOM 928 ACD.

1. WECO 2B Automatic Call Distributor (ACD)

The WECO 2B is used in high activity FSS units, and performs automatic distribution of calls in order of their arrival. The ultimate capacity of the distributor is 78 output positions and 68 incoming trunks which can be housed in 4 cabinets. Some of the system features are:

- o Attendant Position Equipment consists of a flush-mounted 12-, 18-, or 30-button console, with a headset and rotary dial. At the A/G positions, a six-wire "TELCO jack" interfaces the headset/push-to-talk switch to the radio channel equipment through the radio transfer key of the console

(for using the same headset for both A/G and TELCO operations). An intercom capability allows inter-communication between attendant, supervisor console, and other FSS administrative or maintenance positions.

- o Supervisor's Console includes the features as attendant positions, plus provisions for recording and monitoring a delay announcement, concealed monitoring of attendant positions and, controls to activate overflow and alarm conditions.

(NOTE: The WESCON 928 ACD unit also provides similar capabilities.)

2. WECO 4A Call Distributor

The WECO 4A call distributor is a simpler and smaller capacity unit, which is employed at flight service stations requiring up to 20 incoming trunks and 15 attendant positions. The system does not distribute the incoming calls automatically in the same manner as the 2B ACD. Each incoming call is displayed on all attendant positions, and any available attendant can answer the call by pressing the appropriate pushbutton.

The order of arrival of the incoming calls is indicated by flashing the lamps at different rates (fluttering for the first one, then flashing for subsequent calls). Therefore, the only call receiving priority is the first call. This unit is relay type equipment designed for general application and has many features not directly applicable to the FAA requirements.

3. WESCOM 928 Automatic Call Distributor

The WESCOM 928 system is being used as a prototype for specification requirements determination for future FAA-owned FSS telephone systems [13]. The 928 ACD is a solid-state unit employing a crosspoint switching array, and distributes calls in a circular order to all available nonbusy attendant positions. A 30-second delay announcement is repeated at 60-second intervals for all unattended calls (10 seconds waiting time). Like the other ACDs, the WESCOM 928 provides the controller with the ability to terminate into the radio channel equipment; it also transfers incoming calls to either another position or a subscriber line (private line, e.g., National Weather Service).

VIII. TERMINAL COMMUNICATIONS SWITCHING SYSTEM

A Terminal Communication Switching System (TCSS) requirement was prepared by FAA in the early 1970's for use in FAA Air Traffic Control (ATC) Terminal Control facilities [14]. The resulting system provides nonblocking, decentralized control voice communication, including ATC communications within the Dallas/Ft. Worth terminal facility (ATCT and TRACON), at air-ground radio transmitter/receiver sites and other FAA Air

Traffic Control facilities. TCSS utilizes Frequency Division Multiplexing (FDM) techniques for the communications functions, and is stored program controlled employing coaxial cable as the primary means of signal distribution.

The Amecom Division of Litton Systems was awarded the contract to provide all necessary engineering management, services and materials to design, develop, fabricate, test, deliver and install the equipment. The system was installed at the Dallas/Ft. Worth airport and commissioned in July, 1975.

TCSS was designed to provide sophisticated capabilities in terms of operational features as well as easy maintenance, accommodation of orderly growth and minimal on-site installation effort. Its major functions are provision of intercom, interphone and radio communications. Administrative communication is provided by a PABX, which can be accessed by the TCSS.

This system is of particular interest because it is the only major voice switching system operated by the FAA which exclusively employs modern solid state circuitry. The analog circuits are primarily integrated circuit operational amplifiers, although limited use is made of custom hybrid circuits. Digital circuits are primarily standard MSI devices but some LSI devices are used. The distributed control function is implemented by

utilizing an Intel 8008 microprocessor-based-controller at each position.

All of the basic FAA IC/IP functions are provided plus several unique functions, including: 1) software based, re-configuration of the communications capability of each position; 2) radio communications and control integrated with IC/IP voice switching; and 3) traffic data collection. Other unique aspects of this installation are: 1) the system is owned and maintained by the FAA; and 2) signal distribution is by coaxial cables which reduces facility cabling and makes expansion of the system less difficult. Satisfactory system availability is achieved by a combination of mil-specification components, hardware redundancy (primarily power supplies), functional redundancy provided by the reconfiguration feature, and system maintenance by module replacement.

The TCSS connection times for various activities are:

| | |
|---------------------------|---|
| PTT Activation: | 50 Milliseconds Maximum |
| IA Selection: | 50 Milliseconds Maximum |
| Radio Channel Selection: | 50 Milliseconds Maximum |
| Intercom Call: | 250 Milliseconds Nominal, 500 Milliseconds Maximum |
| Main/Standby Switchover: | 1 Second Maximum |
| Interphone Direct Access: | 2 Seconds Maximum |
| Reconfiguration: | 5 Seconds Nominal, 10 Seconds Maximum |

A. Operational Features

All basic features normally required in a FAA facility for IC/IP functions are incorporated in the TCSS. These functions provide a variety of call placement and answer features to permit rapid, unambiguous call processing. These features, as implemented by TCSS, include the following capabilities:

- o Direct access (DA) calling is accomplished by depressing a single pushbutton to communicate with the party identified by the light-emitting diode (LED) display (unique to TCSS) associated with the selected pushbutton. Ring-back intercom, intercom override, and interphone voice calls can be placed via direct access.
- o Indirect access (IA) calling is accomplished by pushbutton dialing, using the 10-digit dialer module provided at each position. All intercom and interphone calls can be placed via indirect access by dialing the subscriber number (intercom call), the trunk access number (interphone voice call), or the trunk access number followed by the subscriber number (interphone SS-1 and PABX calls).
- o Combined DA/IA calling is accomplished by first depressing a single pushbutton to access the interphone trunk identified by the LED display associated with the selected pushbutton, followed by dialing the desired subscriber number, using the 10-digit dialer. SS-1 and PABX interphone calls can be placed via DA/IA.
- o Whenever an intercom/interphone call arrives from a party identified on one of the LED displays on a DA panel, the associated DA pushbutton flashes to indicate the incoming call.
- o Whenever an intercom/interphone call arrives from a party not identified on any LED display, the call is queued in the position common answer (CA) feature.

- o Override intercom calls may be placed via DA or IA, and provide automatic call connection on a conference basis. Several positions can be simultaneously conferenced via override calling.
- o Each position with radio communications capability is provided with two or five radio modules, for access to 12 or 28 radio channels, respectively. Each radio module has up to six radio channel frequencies assigned, as indicated on the six-digit LED displays at the leftmost end of each radio panel. For each assigned channel, the controller at a position can independently enable transmit and receive capability, and can independently select main or standby transmitters and receivers.

1. Call Control

Some other noteworthy call control features are incorporated in the TCSS, which are identified at the position by LED displays and are initiated by the depression of the corresponding DA pushbuttons:

- o HOLD: Places an incoming PABX call in hold, permitting any other call to be placed or answered without losing the held PABX call.
- o COMMON RELEASE: To terminate any call in progress, except an incoming override call.

The Incoming call transfer feature includes:

- o Headset/loudspeaker transfer (HL) to direct specific calls to either the position headset or loudspeaker.
- o Override headset/loudspeaker (OHL) for incoming intercommand override calls.
- o Radio headset/loudspeaker transfer (RHL) for incoming radio communications on select channels.

The RME stores up to 10 maps (System Communications Configurations) and, upon RME operator command, transmits the data from the selected map to the control element (microprocessor) at each ATC position. This data is presented to the ATC position operator on the DA pushbutton and Radio LED displays, and appears as position I.D. numbers (for ringback and override intercom calls), trunk I.D. numbers (for voice call, SS-1 and PABX interphone calls), Special Function Codes and channel frequencies (for Radio communications). By this process, each position is configured for the specific communications capability contained in the selected map. In addition to configuring the DA pushbutton and radio LED displays, the map data transmitted to each ATC position sets up the class of service markings. During system reconfiguration, the RME also transmits map data to the Voice Call Matrix to establish the Voice Call Sectors.

Reconfiguration can be accomplished in one of three ways:

- o Global Reconfiguration - Upon RME operator command, configuration data from the selected map is transmitted to all system positions.
- o Local Reconfiguration - This is similar to the Global Reconfiguration except that map data is transmitted only to those positions selected by the RME Operator.

- o Automatic Reconfiguration - Whenever a position is brought on-line the position microprocessor transmits a reconfiguration request to the RME. Upon receipt of such request, the RME transmits data from the current system map to the requesting position only.

4. Traffic Data Collection

Depression of any pushbutton at a position to initiate, answer, or terminate a call is recorded by the RME. The microprocessor at each position transmits coded data to the RME, identifying the pushbutton depressed; the RME formats this data, together with position I.D., time-of-day, and current map number, and records the information on IBM-compatible 9-track magnetic tape. The recorded data can then be reduced, off-line, to determine the number of calls handled at each position, source, destination, time of placement and duration for each call. The results of the data reduction can then be used to determine the distribution of traffic load per position.

B. Equipment Descriptions

The purpose of the FAA's Terminal Communication Switching System program was to accommodate the diversified and complex nature of the Air Traffic Controller's voice communication requirements by a state-of-art computer controlled stored program

and solid-state/integrated circuit electronic switching system [14]. The system shown in the Figure C-22 was installed at the new Dallas/Ft. Worth facility. Through computer control, greater flexibility and speed of communication in performing the required functions is provided, e.g.: direct access intercom, with and without override; voice call; remote radio control; selective signalling; Automatic Terminal Information Service (ATIS); tape recording of all ATC voice communications; and access to and from long-line trunks. Additional requirements were imposed on TCSS to allow for greater flexibility and growth capability for application in the upgraded third generation (UG3RD) ATC communication system.

TCSS employs distributed control and switching. Voice and signaling data are multiplexed onto a redundant pair of coaxial cables. Dedicated FDM channelization results in a non-blocking switching system, and the communication via coaxial cable provides a bounded transmission medium which is isolated from the environment of the ATC facility.

The switched voice and signalling are modulated (single-sideband AM), and then FDM multiplexed, resulting in a high quality transmission isolated from interference due to the surrounding environment. Full duplex, equivalent 4-wire transmission is provided throughout the system.

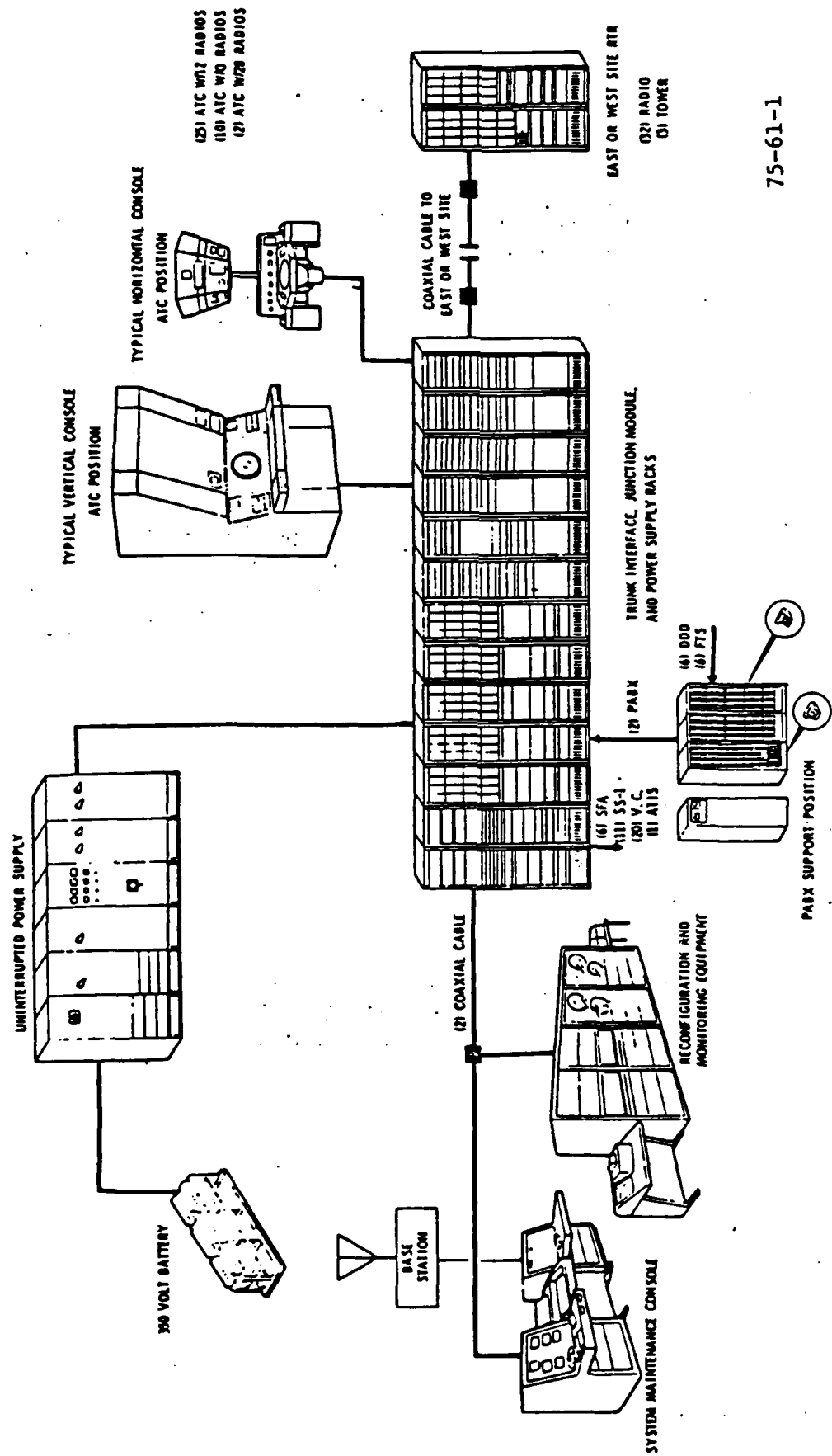

75-61-1

Figure C-22 SUBSYSTEM DISTRIBUTION

Because voice and signaling data are included in the coaxial cable transmission, the physical system control interface connections are minimized. Multiplexed signals are transmitted in two bands, approximately 10 to 12.5 MHz and 12.5 to 15 MHz. With a channel spacing of 10 kHz, about 200 usable full duplex channels are obtained. Signalling is accomplished by an FSK signal located above the upper limit of the voice band (3,000 Hz) in each FDM channel. Relatively low data transmission rates (300 and 600 baud) are used. A 5 MHz reference signal is transmitted on the coaxial cable to all subsystems as required. The frequency standard is redundant.

To provide error detection capability, all signalling and data transmissions are encoded by the distributed control at each position and trunk. In response to each transmission error at a receiving unit, a retransmit request is returned to the transmitting unit, which automatically re-attempts the transmission, to reduce the probability of lost calls.

The primary power is 208V, 3 phase, 4-wire at 60 Hz and a power line drain is 32 kva. An uninterruptable power system (UPS) is provided which is capable of operating the system for more than 30 minutes. [14]

1. Major Subsystems

A summary of racks and modules constituting the system is as follows:

| | |
|-----------------------|-------|
| ATC Positions | 38 |
| Junction Modules | 13 |
| Power Racks | 9 |
| RTR Modem Racks | 4 |
| Trunk Modem Racks | 3 |
| RME Modem Racks | 2 |
| TELCO Interface Racks | 2 |
| RME | 1 |
| SMC | 1 |
| Coaxial Cable System | 1 |
| PABX (External) | 1 |
| UPS | 1 |
| | <hr/> |
| Total | 76 |

The TCSS equipment consists of six major functionally and physically distinct subsystems. These six subsystems are:

- o POSITION/JUNCTION MODULE SUBSYSTEM. This subsystem includes all controller position equipment which provides the intercom, interphone and radio communications capability to the controllers, as well as the junction module interface between each controller position and the coaxial cable transmission medium.
- o SYSTEM MAINTENANCE CONSOLE (SMC). The SMC provides the system real time quality control monitor capability, with associated fault status indication and printout, and the maintenance communications position (MCP) capability by which the maintenance personnel can establish voice communications for information, monitor and test purposes.
- o RECONFIGURATION AND MONITOR ELEMENT (RME). The RME is a centralized equipment group which provides the system reconfiguration and traffic data collection capabilities.

- POWER SUBSYSTEM. This subsystem provides total TCSS system power, via an UPS as well as power distribution within the system via the power supply racks.
- INTERFACE SUBSYSTEM. Provides all system interfaces to the RME and to external communications equipment such as interphone trunk circuits and RTR sites.
- SUPPORT COMMUNICATIONS SUBSYSTEM. A private automatic branch exchange (PABX) provides administrative and support personnel with the capability to communicate among themselves, with TCSS ATC positions, and with external locations via the FTS and DDD networks. This subsystem also includes the order wire telephone at the RTR sites.

2. Position Equipment

The TCSS position equipment is installed in TRACON horizontal and vertical display positions, and tower consoles. A horizontal position installation is shown in Figure C-23 [14]. The individual elements e.g., push buttons, headsets, speakers, and chime controls are designed and located for convenience at the position.

The ATC position modules provide the operational interface between the Air Traffic Controller and the TCSS, and are grouped in various combinations for installation in the operator's consoles to form the ATC position equipment [15] e.g.:

- The Direct Access Module provides the air traffic controller with the capability to place or answer a call by depression of a single pushbutton. Each DA pushbutton contains an indicator lamp to provide call signalling and is adjacent to a 6-digit alphanumeric

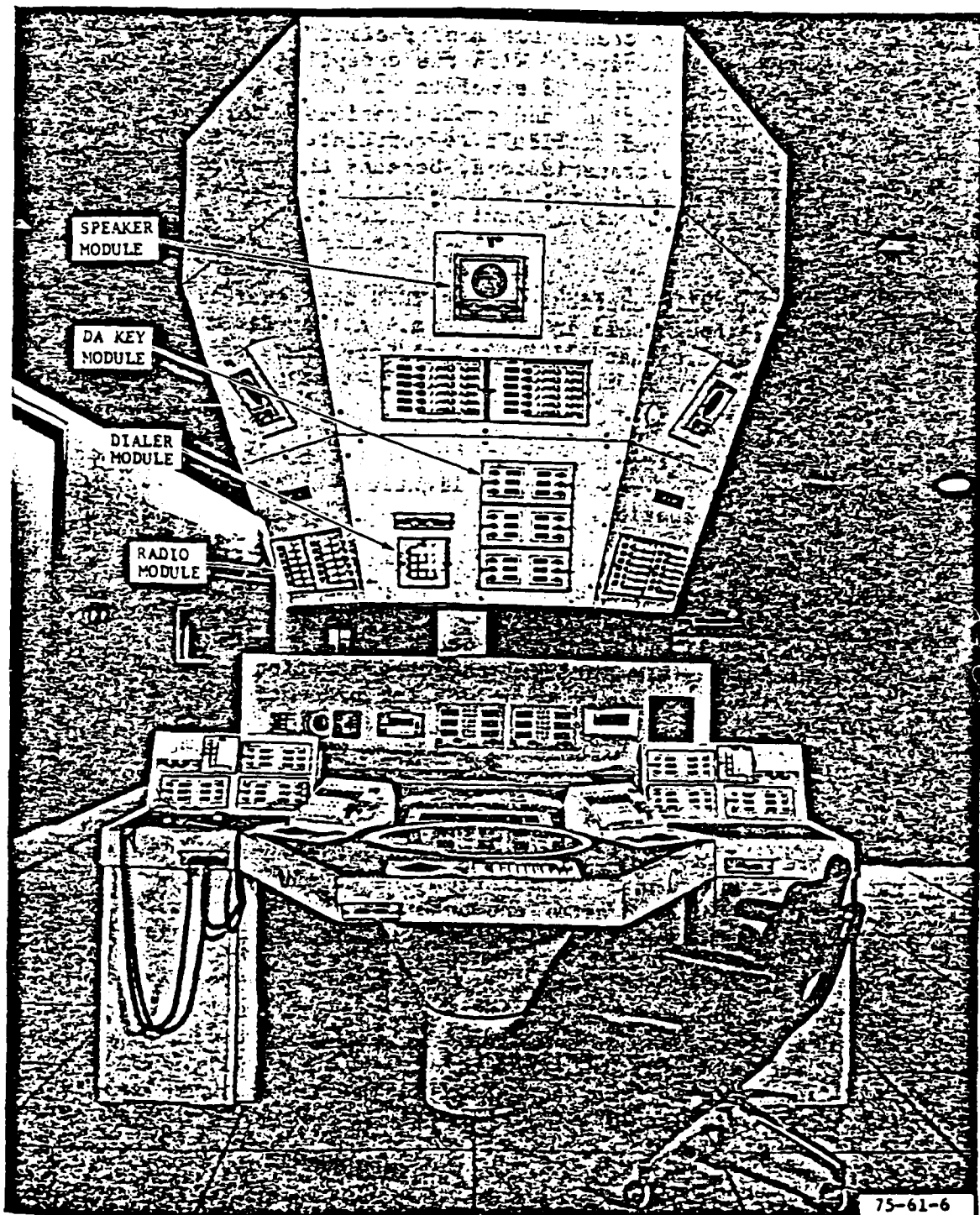

Figure C-23 TCSS INSTALLATION ON HORIZONTAL DISPLAYS IN TRACON

LED display which contains the identity of the position or trunk with which communications will be established when the DA pushbutton is depressed. The contents of the LED displays are controlled by the Reconfiguration function.

- The Indirect Access Module provides the air traffic controller with the capability to place calls to any ATC position or Interphone trunk, on a dial-up basis. The IA Module also provides the Common Answer (CA) capability for answering calls queued in the Common Answer feature. All pushbuttons on the IA module are backlit, and the IA and CA pushbuttons also include indicator lights which provide call signalling indications. At the upper end of the IA module is a green indicator lamp which signals the arrival of incoming override calls.
- The Radio Module provides the capability to select radio channels for establishment of communications with aircraft. Each selectable radio channel is identified, by frequency, on a 6-digit numeric LED display at the leftmost end of the radio panel. Main/standby selection is provided for each channel's receiver and transmitter, independently. Two additional indicators are provided for each radio channel: an amber VOICE indicator blinks at a syllabic rate whenever there is audio received on the corresponding channel; a red STATUS lamp indicates whether a transmitter is free, is being accessed by the position controller, or is being accessed by a sharing position.
- The Speaker Module contains the position loudspeaker, the independent volume control knobs for the headset and loudspeaker, and the position chime which provides audible indication of incoming Intercom/Interphone calls.
- The Dimmer Module contains the independent brightness control knobs for all LED displays and for all pushbutton and indicator lamps on the DA, IA, and Radio Modules.
- The Jack Module has provision to plug in an operator's headset (or handset) and a monitor headset (or handset). The monitor jack incorporates a PTT over-

ride for use during training periods. Removal of all headsets (or bundles) from the jack module disables all position controls except for the brightness and volume controls.

- o The Position Electronics unit is not an operator interface module but one unit is physically located at each position. This unit contains the position controller (microprocessor), and the audio, RF, and digital circuitry which provides the control and communications interfaces to the other position modules, and to the Junction Modules (located in the common equipment racks).

The combination(s) of position modules which make up an ATC position communications complement for the Dallas/Fort Worth TCSS are:

| | |
|------------------------|---|
| Position Electronics | 1 |
| Direct Access Module | 3 |
| Indirect Access Module | 1 |
| Speaker Module | 1 |
| Dimmer Module | 1 |
| Jack Module | 1 |
| Radio Module | 10 Positions with None 25 Positions with 2 3 Positions with 5 |

3. Support Private Automatic Branch Exchange (PBAX)

The support PBAX subsystem is actually a separate system external to the TCSS, but installed with the TCSS by Amecom. It provides the communication facilities among

administrative and support personnel, as well as the access to the Federal Telephone System (FTS) and Telco's DDD networks for the external communications.

The PABX interface with the ATC position communications subsystem is via the PABX modems, permitting the air traffic controllers to communicate with administrative and maintenance personnel. The PABX subsystem contains a power supply with battery reserve, and a Main Distribution Frame (MDF).

4. System Maintenance

The TCSS maintenance is performed both in on-line and off-line modes. The failed major units are identified and replaced on-line, which is followed by off-line isolation and the replacement of the faulty card/module within the unit.

On-line Maintenance Equipment includes a System Maintenance Console (SMC) which consists of the Real Time Quality Control Monitor (RTQC), the Maintenance Communications Position (MCP), and a Teletype printout unit. It is supported by Order Wire links (for communications between the SMC and each RTR site East or West), as well as a testboard at the TELCO trunk interface equipment (for connection to

either the line side or the drop side circuits) for performing make busy tests, to establish an out-of-service condition for any line under test, and to originate or monitor calls.

An off-line maintenance facility simulates the system interconnections to each major unit of the system, for troubleshooting and isolation of faults within the unit to the card/module level, and for replacement. This is performed at a Test Console equipped with special test circuitry and the interconnecting cables for supplying power, audio, RF, and digital data inputs to the unit under test. This unit has the display and conversion circuits to interface the unit output for the display, recording, and teletype printout; it also provides the operator controls to establish the data formats and the circuit selection for the unit under test. Terminals are included to interface the input and output parameters with external generators, oscilloscopes, meters, and other standard test equipment.

IX. WECO 304 CONFERENCE SWITCHING SYSTEM

A WECO 304 conferencing system is a custom designed switching unit serving the FAA System Command Center (SCC). [16] It is a specialized exchange developed by Bell Telephone Laboratories in

the early 1960's, at the request of NASA, to serve the conferencing needs of the control center of the global satellite tracking network. A block diagram of this system is depicted in Figure C-24.

The system may handle as many simultaneous conferences as the number of links in the system, each of which may include a practically unlimited number of conferees located anywhere. Two control consoles are provided, and unless the traffic warrants, one attendant may control the system. The attendant maintains the transmission quality of each line to keep the line noise low.

A. Operational Features

The 304 system terminates both two-wire and four-wire lines which can be connected to the same conference. It will accommodate voice, data, and facsimile traffic on a point-to-point, broadcast, or conference basis. The data system can be either half-duplex or full-duplex, and, if full-duplex, the data can be transmitted simultaneously either at the same frequency or at different frequencies. Common control functions such as signalling, transferring of calls, releasing lines or conferences, etc., are controlled by a dial and 13 common keys and lamps.

Attendants can establish conferences and originate outgoing

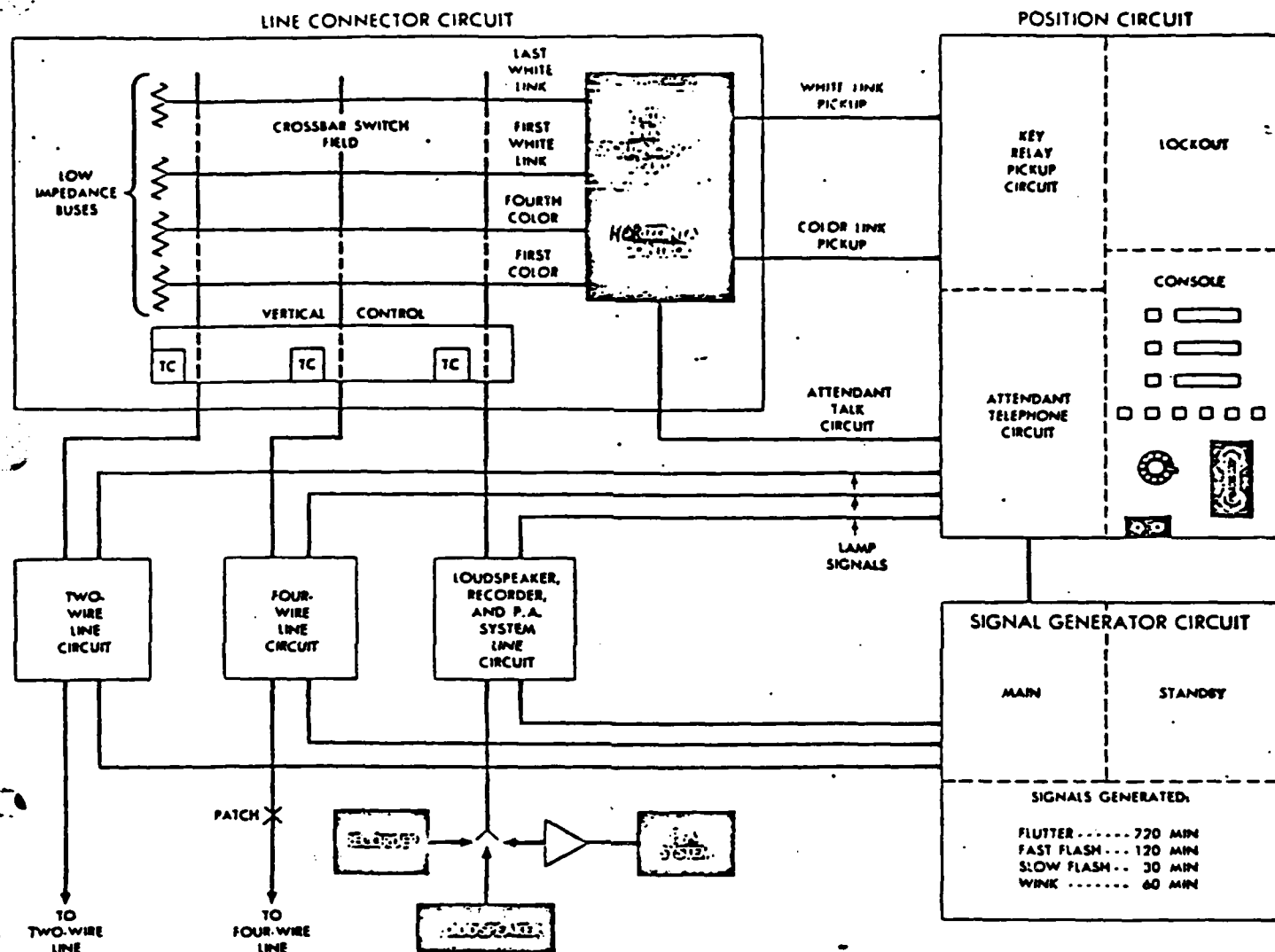

A pushbutton console controls the establishment of connections through the lines and links of a crossbar switch field in the Line Connector Circuit.

WECO 304 Conference Switching System Block Diagram

Figure C-24

calls, answer incoming calls, transfer lines from one conference or link to another, identify the conferees of any particular conference, and participate in any conference. They also control a group of recorders and loudspeakers which may be connected to any conference, and there are provisions for connecting to the public address system.

The design approach adopted by Bell Labs for the system is shown in Figure C-25. The transmission line impedance consists of a few elements in parallel:

- o Two amplifier terminations associated with non-echo protected lines.
- o Terminations of all echo protected lines.
- o A resistor.
- o A trimmer potentiometer.

The last two elements are chosen and adjusted to cause the impedance of the line with one line connected to be three ohms. Up to 122 lines may be connected before the resistance needs readjustment (i.e., to be lowered by one percent). For non-echo protected lines, bridging loss is negligible until approximately 300 lines are connected. For lines with round trip delay less than 12 milliseconds the sidetone is derived from the conference bridge, else a local sidetone at the end is provided to mask the echo.

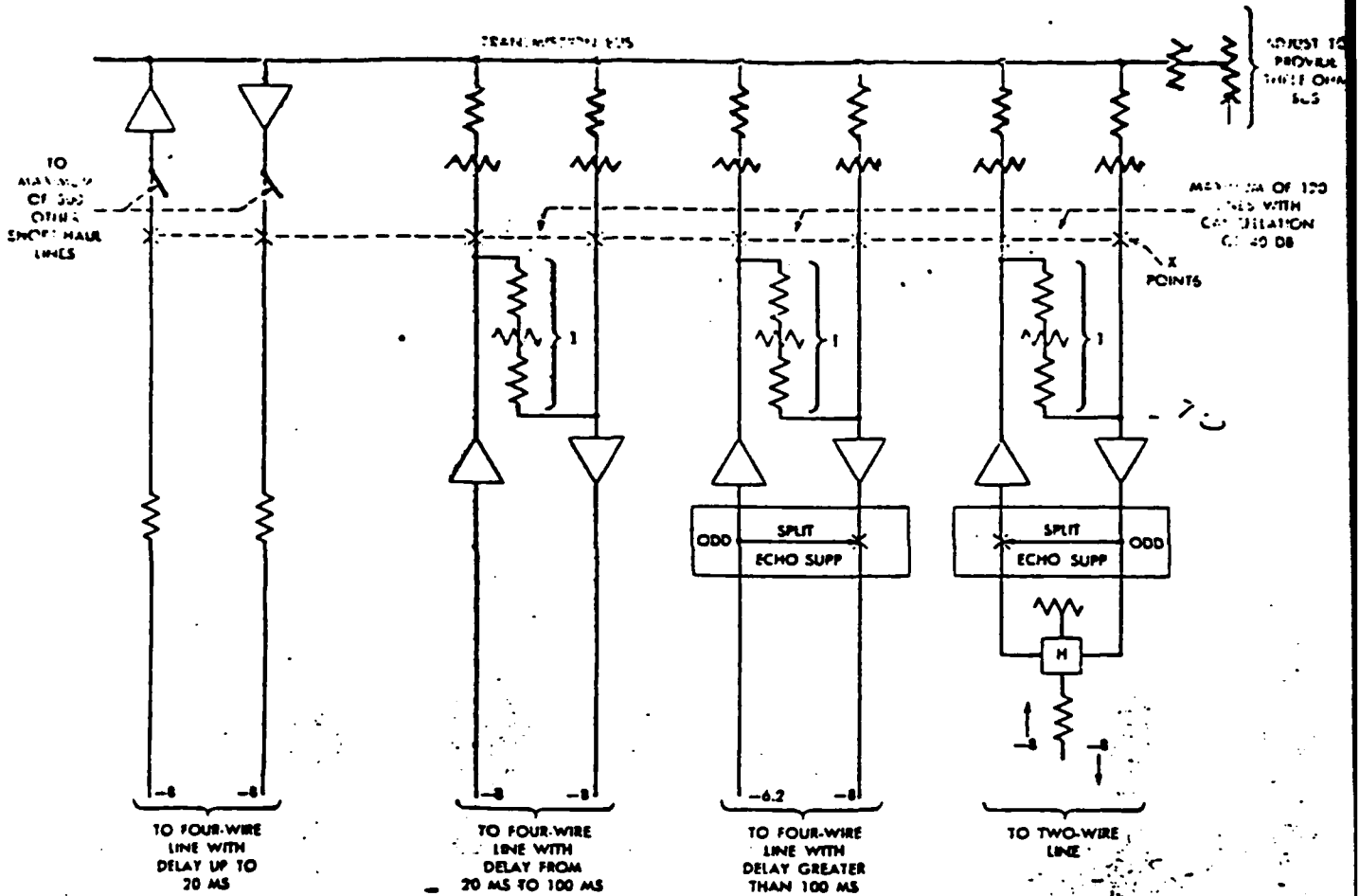

The Transmission Plan Adopted for the 304 Switching System

Figure C-25

Other important system feature includes seven lamp signals associated with each line pick-up key. Three common release keys provide for position release, line release and link release. A fourth, master release key, must be operated simultaneously with the link release key to release all lines connected to a particular link. A number of other keys allow the attendants to perform many required functions including alarm cut-off. Signalling on lines requiring manual ringdown is done by operating signal key.

B. Equipment Description

The WECO 304 conferencing system allows conferences between a large number of lines of four different types. However, this involves major technical problems, the most important being the echo path to the talker through the line amplifier. Use of amplifiers on long lines to provide uniform inputs/outputs on the conferencing circuits is precluded due to their amplitude and and/or phase drift.

The conferring lines can be divided into four logical categories and their interface with the bus is:

- o Lines not requiring echo protection (4-wire lines with round-trip delay less than 20 milliseconds).
- o Lines requiring line amplifiers and isolation resistors (4-wire lines with round-trip delay between 20 and 100 milliseconds).

- o Lines requiring a split echo suppressor, line amplifier, and isolation resistor (4-wire lines with round-trip delay greater than 100 milliseconds).
- o Lines requiring a split-echo suppressor and a hybrid coil, line amplifiers, and isolation resistors (2-wire lines).

A pushbutton console controls the establishment of connections through a crossbar switchfield in which lines are associated with verticals and conference links with horizontals. In each conference link a low impedance transmission bus is included which permits a number of lines to be bridged simultaneously with no appreciable transmission loss. Twelve separate paths are required for each line-to-link connection, the crossbar switch bare wire multiples are severed in the center and two verticals are associated with each line. A lockout circuit prevents interference between positions, avoiding false or double connections. Loudspeakers, recorders, and public address systems are connected to verticals the same way lines are connected, hence they may be associated with any conference. The pushbutton controls and lamp signals tied in with the recorders, loudspeakers, and public address systems are identical to those employed in line connection.

X. SUPPORT PBX FOR ADMINISTRATION AND MAINTENANCE

These support PBX switching units are provided for interconnecting the administrative and maintenance personnel and their

telephone communication to the public TELCO telephone network subscribers. These installations vary in capacity and are mostly procured on leased basis from the local TELCO. The enclosed Table C.4 lists the features of the WECO PBX normally service this FAA function.

In addition to WECO units, some other systems, e.g., NORELCO, ARD-561, and the GTE System, are employed at discrete FAA facilities.

The FAA switching systems operational in 1980's and beyond will be implemented with a technical control capability which includes:

- o Automatic and remotely controlled status and performance monitoring
- o On-line and off-line diagnosis
- o Fault isolation, and certification
- o Routine special status reporting and logging

This capability will extend beyond the individual system and provide the input to, and the operational interface with, an overall NAS technical control system

The most common maintenance operations presently being performed manually are: patching, coordination, testing, monitoring, reporting, fault isolation, repair and certification. These are candidates for automation. The introduction of a modern state-of-

the-art switching system will automate it and make it more efficient and economical. Moreover, the availability will be increased to near 100%, by:

- o Higher MTBF of equipment
- o Automatic and fast switch-over of redundant units
- o Programmed maintenance, use of failure prediction and
 - fault trend detection methods
- o Lower MTTR through module replacement
- o Use of the centralized maintenance console with adequate
 - remove testing capability, and indications for intermittent failures and faults
- o Real time quality control with alarm cue repairs before catastrophic failures.

Table C.4

Specification of Most Commonly Used WECO PBX
for FAA Administrative/Maintenance Use

| | 1 | 2 | 3 | 4 | 5 | 6 | 7 | 8 | 9 | 10 |
|--------------------------------|------|------|------|------|------|------|------|------|----------------|---------|
| System Feature | 701B | 740E | 756A | 757A | 770A | 800A | 801A | 805A | 812A | 101 ESS |
| Attendant Conference | 0 | 0 | 0 | 0 | 0 | 0 | 0 | No | 0 | 0 |
| DSS | No | No | 0 | 0 | 0 | 0 | 0 | No | No | No |
| Restriction | | | | | | | | | | |
| Direct Trunk Transmission | | | C | C | C | | | | | |
| Switched Loop | C | | | C | C | | | | | |
| Attendant Trunk | S | S | S | S | S | S | S | S | S ¹ | S |
| y Lamp Field Only | 0 | 0 | | | | | | | | |
| Busy Verification - Station | 0 | | 0 | 0 | | | | | 0 | |
| Call Transfer - Attendant | S | S | S | S | S | S | S | S | S | S |
| CCSA Access | 0 | 0 | | | | | | | 0 | 0 |
| O. Trunk Termination | S | S | S | S | S | S | S | S | S | S |
| Code Call | 0 | 0 | 0 | 0 | 0 | 0 | 0 | | 0 | 0 |
| Code Restriction | | | | | | | | | 0 | 0 |
| Conf. Calling - Attendant | 0 | 0 | 0 | 0 | 0 | 0 | 0 | | 0 | 0 |
| Station | | | 0 | 0 | | 0 | 0 | | | |
| Controlled Station Restriction | 0 | | | 0 | | | | | 0 | |
| DOD | S | S | S | S | S | S | S | S | S | S |
| Direct Trunk Termination | | | | | | | | | | |
| Switchboard | C | C | C | C | | C | | | | |
| Console | S | | S | S | S | S | S | S | | S |
| Fully Restricted Station | 0 | | | 0 | 0 | | | | 0 | 0 |
| Incoming Call Ident. | 0 | | | 0 | | | | | S | 0 |
| Out | | | | | | | | | | |
| Exchange Network | C | C | C | C | C | C | | C | | C |
| Access Line | C | C | | C | | | | | | C |

1 = Feature

2 = Feature

3 = Feature required at no extra charge

1 = Switched Loop Operation only

2 = Equipment required at Central Office (C.O.)

3 = Equipment required at C.O. and segregated trunk groups required

4 = Includes all types of trunks

C.4 (continued)

| | 1 | 2 | 3 | 4 | 5 | 6 | 7 | 8 | 9 | 10 |
|----------------------------------|----------------|----------------|----------------|----------------|----------------|----------------|----------------|------|----------------|---------|
| System Feature | 701B | 740E | 756A | 757A | 770A | 800A | 801A | 805A | 812A | 101 ESS |
| Manual Line Service | | | | | | | | | | |
| Switchboard | 0 | 0 | 0 | 0 | | | | | | |
| Message Waiting | 0 | | | 0 | 0 | | | | 0 | |
| Misc. Trunk Restriction | C | C | C | C | C | C | C | | C | C |
| Night Service | S | S | S | S | S | S | S | S | S | S |
| One-Way Splitting | | | | | | | | | S | |
| Paging-Loudspeaker | 0 | 0 | 0 | 0 | 0 | 0 | 0 | | 0 | 0 |
| Paging-Radio | 0 | 0 | 0 | 0 | 0 | 0 | 0 | | 0 | 0 |
| Power Failure Transfer | S | S | S | S | S | S | S | S | S | S |
| Recorded Telephone Dictation | 0 | 0 | 0 | 0 | 0 | 0 | 0 | | 0 | 0 |
| Reserve Power | 0 | 0 | 0 | 0 | 0 | 0 | 0 | 0 | 0 | S |
| Restrictions from Outgoing Calls | S | S | S | S | S | S | S | S | S | S |
| Secrecy (With Lockout) | | | | | | | | | | |
| I/C Exchange Network | C | C | C | C | C | | | | | |
| CCSA Access Line | C | C | | C | | | | | | |
| Single Digit Dialing | 0 | | | 0 | 0 | | | | 0 | |
| Station DSS | 0 | | 0 | 0 | | | | | | |
| Station Hunting | S | S | S | S | S | S | S | S | S | S |
| Station Message Registers | 0 | | | 0 | 0 | | | | 0 | |
| Station-to-Station Calling | S | S | S | S | S | S | S | S | S | S |
| Supervisory Cabinet | C | | | 0 | | | | | 0 | C |
| Switched Loop | | | | | | | | | | |
| Switchboard | C | | | | | | | | | |
| Console | C | | | C | 0 | | | | S | S |
| Tie Line Service | 0 | 0 | 0 | 0 | 0 | 0 | 0 | 0 | 0 | 0 |
| Toll Denial | | | | 0 | 0 | | 0 | | 0 | |
| Toll Restriction | | | | | | | | | | |
| Per System Basis | 0 ² | 0 ² | 0 ² | 0 ² | 0 ² | 0 ² | 0 ² | | 0 ² | 0 |
| Per Station Basis | 0 ³ | 0 ³ | 0 ² | 0 ² | 0 ² | 0 ² | 0 ² | | 0 ² | 0 |
| Toll Terminal | 0 | | | 0 | 0 | | | | 0 | 0 |

C.4 (continued)

| | 1 | 2 | 3 | 4 | 5 | 6 | 7 | 8 | 9 | 10 |
|--------------------|----------|------|------|------|------|------|------|------|------------------|---------|
| System Feature | 701B | 740E | 756A | 757A | 770A | 800A | 801A | 805A | 812A | 101 ESS |
| Touch Tone Calling | 0 | 0 | 0 | 0 | 0 | 0 | 0 | 0 | 0 | S |
| Trouble Alarms | S | S | S | S | S | S | S | S | S | S |
| Two-Way Splitting | C | C | | C | C | | | | | C |
| Capacity - Lines | No Limit | NA | 60 | 200 | 400 | 80 | 270 | 57 | 2080 | 4000 |
| C.O. Trunks | No Limit | NA | 10 | 43 | 100 | 20 | 40 | 12 | 600 ⁴ | 384 |

XI. FUTURE FAA SWITCHING SYSTEMS

There is a substantial and obvious lag between the current state-of-the-art and FAA's existing IC/IP network switching technology of the 1950's. The electromechanical crossbar and relay exchanges and key systems, which have been a workhorse of FAA, have proven to be reliable electromechanical switches. However, being hardwired, they fall short of meeting the growth and functional requirements of the present and future aviation communication needs which requires a highly flexible system. The computer controlled solid-state electronic switching systems constitute the only state-of-the-art systems within the FAA IC/IP network.

FAA has taken a realistic systems approach, in which due consideration is given to the total communications scenario. Integration of existing separate smaller switching systems into one large combined system is considered the theme and simple centralized automatic maintenance aids have been favored. Flexibility of reconfiguration will have obvious rewards in the form of reduced controller manpower requirements, planning and in meeting emergencies and breakdowns.

The integrated switching system planning approach has recognized and emphasized the importance of shorter features, e.g.:

- o Shorter call handling (call set-up) periods

- o greater connectivity
- o higher reliability
- o higher maintainability
- o system availability

FAA has analyzed the costs critically and sought relief through the use of standard interfaces and universal hardware/software, efficient use of circuits, and centralized management and maintenance. The FAA has originated a series of study, conceptualization, design and development programs aimed at modernization of its switching network; the most noteworthy being the EVSS, the INACS, the EKS, the VSCS, and the SVSS. Details on these systems follow:

A. Small Voice Switching System (SVSS)

Small FAA facilities including low activity towers have limited but sophisticated communications requirements. The FAA has launched a SVSS program to develop a switch which will employ state-of-the-art, fully electronic communications technology [17]. The program will provide voice intercom between tower positions, voice interphone service for communication with larger towers, FSSs, TRACONS, ARTCCs, airlines and other support locations, as well as controlled aircraft communications. The proposed SVSS capacity will be:

| | |
|----------------------|----------|
| Operating positions: | 3 to 10 |
| Interphone trunks: | Up to 20 |
| Radio Channels: | Up to 20 |

Expansion will be easily accommodated and the system will be very flexible in this regard. The system will consist of five main subsystem elements:

- o ATC Position Element
- o Configuration/Switching element
 - Control Processors
 - Switching networks
- o Interface element
 - Radio circuits
 - Interphone circuits
 - Recorder circuits
- o Maintenance element
- o Power supply element

The system design will assure efficient partitioning between the radio functions and the interphone/intercom functions.

1. Operational Features

The principal features specified for SVSS are:

- o The SVSS will act as an interface between,
 - The controller (through the position equipment) and the radio IC/IP elements

- ATC positions and voice recording equipment
- the SVSS and leased telephone company switching systems and standard telephone equipment, such as the 301A, 300, 1A1, through 2 and 4-wire trunks
- o Status lamp indication of circuit conditions
- o Emergency back-up power
- o Facility entrance system intercom connection
- o Other features
 - Intercom (except a connection to facility entrance is standard)
 - Indirect access intercom
 - Direct access intercom
 - Local override
 - Remote override
 - Call forwarding
 - Antenna switching
 - Radio Channel Control Equipment (RCCE) interface

A reconfiguration of SVSS will be required frequently for most efficient utilization of scarce skilled controller manhours; the Configuration Control function and capability will be used:

- o to meet the changing demands of air traffic activity
- o to compensate for equipment failures
- o for appropriate assignment of position interphone and intercom circuits

- o for reassignment of functions assigned to pushbuttons on the PB modules
- o for affecting appropriate changes to any designated radio frequency to the appropriate radio channel selector modules.

2. Equipment Description

The requirements for the SVSS system have been spliced [17]; a conceptual block diagram is shown in Figure C-26. The system consists of:

- o Position equipment for air traffic controllers
- o Backroom equipment which includes equipment for interfacing lines to various local positions, trunks to other FAA and non-FAA facilities, switching matrixes with associated control devices and maintenance and power units.

The environmental constraints of the installations are specified by FAA as +10°C to +50°C and 10% to 80% R.H. The range in case of unattended facilities is somewhat broader.

The external interface requirements of the SVSS system are:

- o Universal Interphone Trunk Circuits - both two and four-wire circuits with interchangeable signalling equipment, jack circuits and protection equipment (trunk circuit type numbers 3, 4, 6 and 9, together with override trunks will be accommodated).

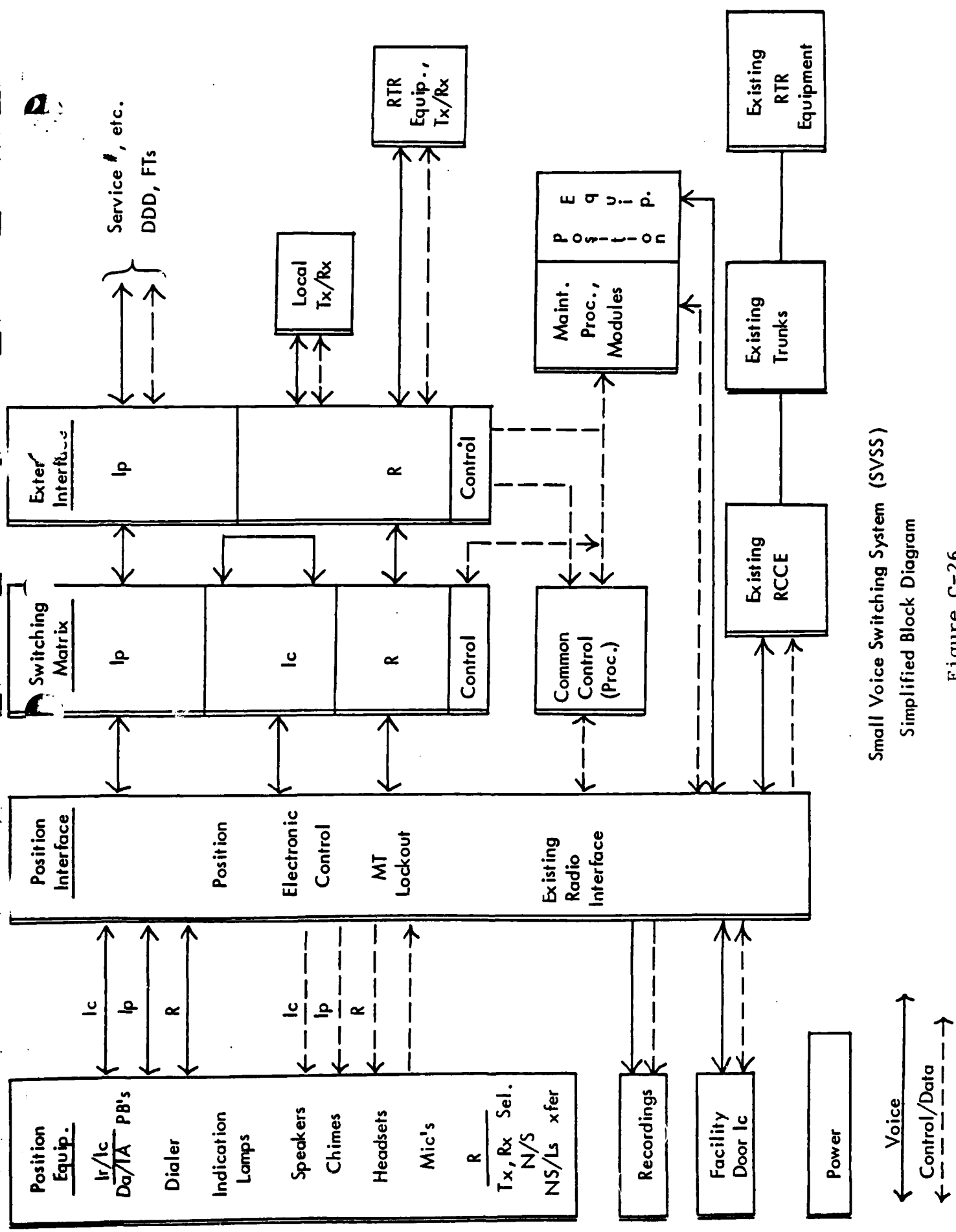

Small Voice Switching System (SVSS)
Simplified Block Diagram

- o Signalling - a number of conventional TELCO signalling schemes will be handled; the most important are:
 - single frequency (SF) signalling,
 - selective signalling (SS-1A)
 - voice call signalling
 - central office and PBX signalling over type 6 trunk circuits.
- o Interface with Common Carrier Circuits - The SVSS will provide the necessary 4-wire conversions, address outpulsing, supervisory signals and audible signals provided with (a standard "beep" tone to the distant party to indicate conversation is being recorded). Tandem switching between Direct Distance Dialing (DDD) lines, between Federal Telecommunications System (FTS) lines, and between DDD and FTS lines, will be prohibited at SVSS.
 - Tariff FCC no. 260 (voice/data to other facilities, 4-wire series 3002 channel without C-type conditioning).
 - Tariff FCC no. 259 (FTS network, for interstate links between adjacent switching systems)
 - Tariff FCC no. 263 (2 and 4-wire circuits for support communications to local PBX, intra- and inter-state voice communications).

For an aviation telecommunication switching system, the highest reliability, maintainability and availability requirements have been stipulated by FAA. The single thread availability of any function shall be no less than 0.9999, with a maximum time to restore limited to 0.5 hours. The system will incorporate the capability for transmission of maintenance status information to a remote control maintenance facility.

The SVSS system will fulfill the specified stringent performance requirements under light, moderate and full-load traffic of up to 180 calls during busy hour, with a holding time of 30 seconds per call, and a grade-of-service of 0.001 for intercom/interphone and non-blocking for radio.

3. Position Equipment

SVSS position equipment will be used to accommodate air traffic controllers and will consist of a console with a number of pushbutton sets and other non-electromechanical flush mounted plug-in modules held by fasteners and allowing quick replacement. A number of other modules are incorporated in these positions. Pushbuttons mounted on a number of standard and optional pushbutton modules allow the controller to set up calls to required destinations within and outside an FAA facility, as follows:

- (a) The ATC controllers' position will include a panel of 16 pushbuttons (PB) for actuating the electronically (micro-processor) controlled basic functions, e.g., directing and controlling interphone calls (DDD, FTS and calls to other FAA facilities), intercom calls (calls within the facility, including the facility entrance) and calls to the radio system (calls to pilots in aircraft).

(b) A set of the following pushbuttons will be associated with special functions:

- o Hold PB (non-locking), for establishing a "HOLD" condition on one or more of either CO (central office) or PBX (private branch exchange) circuits to select other radio, interphone or intercom circuits.
- o Release PB (non-locking), for release of a position from any existing interphone or intercom connection.
- o Ring and Flash (R&F), non-locking PB to manually control signalling on trunks equipped for single frequency signalling.
- o Door release, non-locking PB, for access to the door intercom, to unlock the facility door.
- o Interphone/Intercom HS/LS locking PB, for directing the incoming interphone and intercom voices to the headset or the position speaker.
- o Split radio interphone/intercom, locking PB, to permit two controllers to simultaneously use one position, one controller each using separately the radio function and the interphone/intercom.

(c) A group of interlocking circuit selector PBs (with status lamps) allow selection of only one circuit at a time.

- o Interphone circuit selector PB - gives access to interphone trunk circuits, (limit one interphone or intercom circuit at a time). A call may either be completed with one PB operation, (or subsequent dialing may be required) which releases the position from any connected interphone or intercom circuit (except circuits in HOLD).

- o Intercom Circuit Selector PB - gives access to another local position by depressing one of the following pushbuttons (PB):
 - Direct access (DA) Intercom - allows communication between two local positions by operation of this PB. It may be provided in one or both of the following methods:
 - .. DA intercom without override - for access to a local position by a single operation.
 - .. DA intercom with override - for overriding positions that have a direct communications path to the telephone instrument or speaker of an overridden local position. The overriding position joins the circuit on a conference basis (maximum of 5 conferees).
- o Facility Entrance Door Intercom provides communication access between one or more operating positions and the door intercom. A separate non-locking PB shall be provided at the operating position to release the door latch.

(d) Other modules included in the SVSS position equipment include a Radio Channel Module, allowing each position an access of up to 12 radio channels. Radio transmitter and receiver selector switches will be provided on the radio channel module, in addition to a PTT switch which causes received radio signals on the circuit to be muted at all positions. Many other useful status indicators, PB's, and switches are also provided for important functions,

e.g., switchover of antenna from main to standby.

(e) This Indirect Access Dialer Module will be a 10 digit pushbutton dial pad, which will permit a position to select a called party's number for indirect access. An incoming override call status indicator will also be incorporated in the module.

(f) A plug-in loudspeaker will be included in SVSS positions. A chime sound will be included in association with each loudspeaker, as well as two volume controls for independent volume control of the headset and the speaker.

(g) A jack module with a dual set of telephone jacks, one for the controller and the other for an instructor. A remote jack module will also be included for accommodating a hand-held microphone.

(h) Audible standard signalling - information tones will be used in addition to chime signalling, which sounds at approximately once a second in the loudspeaker. A choice of any of 5 tones may be assigned to any position.

AD-R126 814

SOCIOECONOMIC IMPACT ASSESSMENT: COMMUNICATIONS
INDUSTRY PHASE 1 TECHNICAL (U) COMMUNICATIONS RESEARCH AND
TECHNOLOGY INC BETHESDA MD 02 FEB 79 FAA-RPD-81-11-2
DOT-FA78WAI-932 F/G 1777

474

UNCLASSIFIED

NL



END
FORM
1777

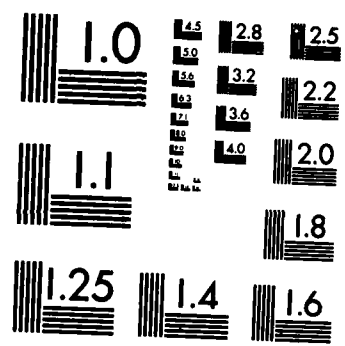

MICROCOPY RESOLUTION TEST CHART
NATIONAL BUREAU OF STANDARDS-1963-A

(i) Side Tones permit the controller to hear his voice transmissions on interphone, intercom or radio operations, in his earpiece when using a headset (not in the position speaker).

(j) The Position Voice Recording Channel collects the voice transmissions/receptions at the position and presents it for recording on the FAA voice recording equipment.

(k) Split Radio Interphone/Intercom Operation allows operation of the position module's radio and the interphone/intercom portions of the system independently and simultaneously by two controllers, without interfering with each other.

4. The Backroom Equipment

The Backroom Equipment will include the following units:

- o Configuration/Switching element
- o Interface element
- o Maintenance element
- o Power supply element.

The configuration/switching element will consist of a pair of dual (redundant) "Control Processors" and the

"Switching Network". The Control Processors complement will include associated I/O and interfacing devices. The required software will be included to perform system control functions, e.g.:

- o Call Processing for the initiation and termination of calls. Processing of service requests, scanning for circuits or line status; controlling and time connections, dial tone, position signals and acknowledgement signals, connection of address receivers, dial or address analysis, supervision and control of telephone and instrument or pushbutton lamp signals and indicators; outgoing or incoming trunk selection and path selection, address outpulsing and trunk supervision.
- o Equipment Control for control, access and supervision of all peripheral equipment (memory systems, message entry devices, switching matrixes (if used) and off-line or standby equipment, etc.).
- o Status Information, such as trunk or equipment availability, traffic load, and fault or error conditions.

The Interface element will provide circuitry to terminate the trunks and lines which connect SVSS to other FAA and non-FAA facilities. The maintenance element will include sophisticated devices for fault detection; reporting these will be maintenance consoles, localization cabinet maintenance panels/alarms, path panels, monitoring/test panels.

The power supply element will obtain the primary power from the local commercial (AC) power. Distribution/conversion/regulation equipment with necessary measuring devices

will be included. The unit will feed the SVSS with the required DC voltage and include protection devices. An emergency back-up power supply will be included using batteries to feed the system for one hour under full-load condition in case of breakdown of primary power.

XII. VOICE SWITCHING AND CONTROL SYSTEM

An important program is being conducted by the FAA to develop a new Voice Switching and Control System (VSCS). This program is nearing the completion of the concept and preliminary system design phase, and the preparation of a system specification is now in process by the FAA. The concept is the result of a design study which evaluated various system architectures as well as the fundamental question regarding combining the radio and IC/IP functions into a single basic system. The system design is intended to be cost-effective over a range of medium to large size systems so that it would be a replacement for both the WECO 300 and 301 systems for ARTCC and TRACON applications, and possibly for large Towers. VSCS will incorporate a subsystem for performance monitoring and fault isolation. A complete description of this system is given in Appendix A.

XIII. THE NAFEC COMMUNICATION SWITCHING SYSTEM (NCSS)

The National Aviation Facilities Experimental Center (NAFEC) has issued a specification for procurement of a voice switching system to meet its very special requirements [18]. The system is of interest to this program since many of the equipment techniques developed will be applicable to the future ATC voice switching systems of the FAA.

The NCSS specification will impose stringent reliability and availability requirements, and demands extreme flexibility for tailoring its configuration to fulfill a very diverse combination of operational and test conditions. The system will be a solid-state unit which will interface with simulated and live lines and trunks associated with the NAFEC interphone, intercom and radio networks.

NCSS will be a versatile unit employed in a variety of operational and test situations and combinations; some of which are:

- o Collection of NCSS data for operational and traffic analysis.
- o The reconfiguration of position assignments to lines and trunks, position direct access keys, position radio keys, and predetermined groups of positions.
- o Scheduled support of simultaneously operated laboratories and facilities to effectively utilize NAFEC resources.
- o Simulation of ATC environments, to assist in developing ATC procedures and equipments.

- o Provision of communications links from various ATC operational positions.
 - to other ATC positions (local or remote)
 - to controlled aircraft either live or simulated by means of radio channels
 - to other external communication networks via a common carrier interface.

A. Operational Features

In addition to providing all the required IC/IP and radio communication functions, the NCSS system will include a number of specialized features in support of the NAFEC mission, e.g.:

- o Incremental functional growth by addition of equipment modules into pre-wired nest positions, or additional subassemblies/functional units [18].
- o Expansion of common control functions by simple program modifications or subroutine additions. Larger enhancements will be possible by modular expansion of the basic processor.
- o Reconfiguration in two dimensions for:
 - Geographic (operational environments), such as large control areas with relatively low aircraft density, quick transient conditions that exist at busy control centers.
 - Positional reallocation of functional capability within an NCSS including control of assigned functions at positions, line/trunk terminations and radio channel allocations.
 - Experimental Support: operation in many different test scenarios simultaneously, with master configuration "maps" depicting commonly used scenarios kept on auxiliary storage for easy entry.

- Availability Restoral: restoration of functional performance in reaction to equipment failures.

This system capacity is shown in the Table C.5. The effective ultimate capacity will be far less than 250, i.e., about 125 positions at any given time, since some positions are not counted as true positions due to their limited capabilities and usage.

B. Technical Equipment

The NAFEC switching system will consist of position equipment and very sophisticated state-of-the-art computer controlled electronic backroom equipment, which are described here [18]. The block diagrams showing the concept of an NCSS is Figure C-27. The NCSS will operate in a voice communication environment. The terminations will consist of ground-ground and air-ground links which will be classmarked. It will allow easy and frequent reconfiguration, partial or total.

The expansion of NCSS will be facilitated by modular construction, to meet future requirements. This will contribute to minimizing NCSS maintenance management; other factors contributing to it will be the optimal system organization high modular reliability, built-in test/diagnostic routines, centralized status monitoring, control and automatic service restoral/reconfiguration.

Table C.5
System Capacity and Modularity [18]

| <u>EQUIPMENT</u> | DESIGN LEVEL CATEGORIES | | |
|--|-------------------------|-----------|------------|
| | <u>I</u> | <u>II</u> | <u>III</u> |
| <u>Sizing</u> | | | |
| Maximum Number of Positions | 150 | 200 | 250 |
| <u>ATC Positions, Enroute and Terminal</u> | | | |
| Positions equipped as: | | | |
| Radio Positions | 91 | 125 | 158 |
| Non-Radio Positions | 51 | 63 | 80 |
| Supervisory Positions | 7 | 11 | 11 |
| Maintenance Position | 1 | 1 | 1 |
| <u>Line Circuits</u> | | | |
| Override | 150 | 200 | 250 |
| Automatic Ringdown (Simulated) | 130 | 150 | 175 |
| Voice Call (Simulated) | 150 | 175 | 200 |
| Radio (Simulated) | 90 | 90 | 100 |
| Automatic Ringdown (Live) | 20 | 25 | 25 |
| Voice Call (Live) | 10 | 15 | 20 |
| Radio (Live) | 15 | 20 | 25 |
| Conference | 15 | 20 | 25 |
| PABX Tie Lines | 15 | 20 | 25 |
| Maintenance Circuit | 1 | 1 | 2 |
| <u>Pilot Laboratory, DSF</u> | | | |
| Pilot Positions | 64 | 80 | 96 |
| Line Circuits Radio (Simulated) | 80 | 80 | 90 |
| <u>Flight Simulation Laboratory</u> | | | |
| Line Circuits Radio (Simulated) | 10 | 10 | 10 |

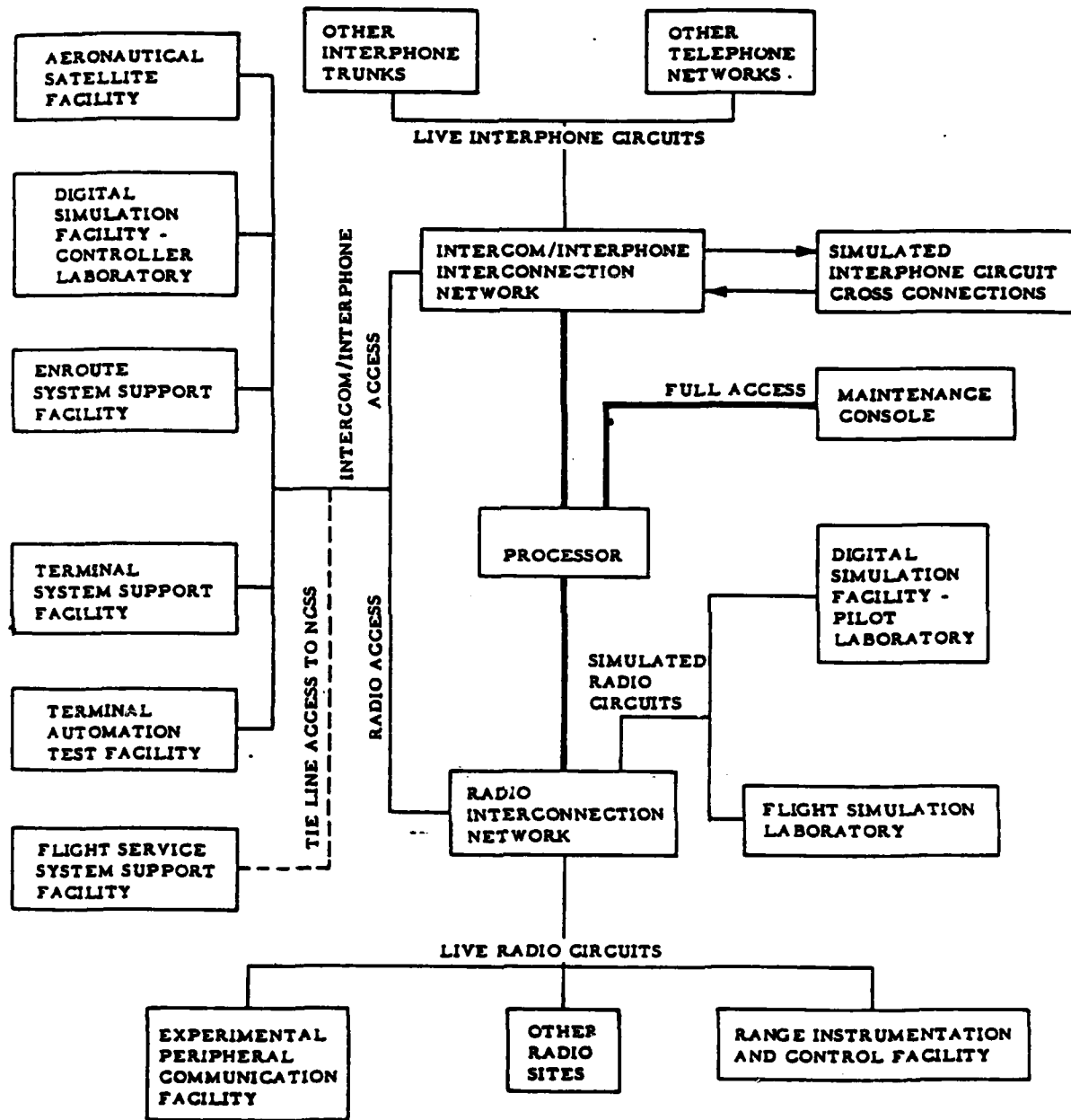

Figure C-27
NCSS Block Diagram

The NCSS Maintenance Repair will be designed on the module replacement principle, and will be aided by utilization of quick-disconnect features. High reliability will be enhanced by utilizing quality components and elements.

The NCSS unit will interface with PABX's, Central Offices, Federal Telecommunications System, Pilot Laboratory of the Digital Simulation Facility, and the Flight Service System Support Facility, as well as remote radio transmitters and receivers.

C. Position Equipment

This unit will be employed at the operating positions. The functions performed consist of requesting and acknowledging communication service and actually transmitting information through speakers, headsets and microphones. All NCSS position equipment in the laboratory/facility operating consoles constitute a human factors man-machine interface, which will functionally and operationally duplicate:

- o The Western Electric 300 Switching System as utilized in the Air Route Traffic Control Center (ARTCC),
- o The Western Electric 301A Switching System as utilized in Air Traffic Control Towers (ATCT) and Terminal Radar Approach Control (TRACON) facilities,
- o The FAA owned radio channel control position equipment.

These positions will have the capability for replacement of the positions and applications in different test scenarios of

various field conditions. They will be highly flexible and will meet the configuration and reconfiguration requirements for accommodating various position equipment situations.

The positions will be allocated through pushbuttons of the standard FAA communication capabilities, e.g., Direct Access (DA), Indirect Access (IA), Conferencing, etc. A number of status indications will be employed to indicate conditions, e.g., OFF, FLASH, FLUTTER, STEADY, or WINK states.

The radio transmitter will be controlled by the push-to-talk switch, if a position is not already overridden. Selection of receive/transmit radio channels will be by radio channel modules, and a transmit interlock feature will prevent other positions from using an occupied channel.

D. Backroom Equipment

The NCSS backroom equipment will consist of: a common control subsystem, a switching subsystem, and all the support equipment.

E. The Common Control Subsystem

This subsystem controls the exchange activity and will include a redundant pair of digital computers, the required software and ancilliary devices.

The main functions and capabilities of the exchange common control subsystem are:

- o Call attempt recognition, reception and setting-up connections, their maintenance and disconnection.
- o Classmark table maintenance on a per termination basis and its analysis for each call attempt.
- o Control of external interfaces to networks, e.g., trunks of other PABX's, FTS, TELCO Central Offices, recognition of signalling and other specific requirements.
- o Configuration map maintenance and interpretation for each laboratory/facility.
- o Indication at each position as to which functional capabilities have been assigned to the position. The functions assigned to a position will be displayed by LED's, LCD's, or similar devices, and include: trunks and circuit designators, radio channels special assigned function pushbuttons.
- o An automatic switch-over to the stand-by unit to assure continuity of service will be transparent to the maintenance crew. A manual switch-over inhibit will also be provided.
- o Automatic data logging will be done on service information, maintenance records on operational parameters and failure statistics, could also be displayed at the Maintenance Console.
- o Real time Quality Control (RTQC) to check for system degradation. The results will be displayed on a Receive-only teletypewriter.

The Support Equipment required in the backroom is not directly involved in the process of carrying the traffic, however, it is important and in some cases imperative to the functioning of the exchange and includes the following capabilities and functions:

- o Maintenance Management Aids shall include equipment (such as Maintenance Colsole) and software (such as Real Time Quality Control), on-line routines continually monitoring the performance, and off-line diagnostic and fault isolation routines.
- o Data Collection Units shall provide a means for re-initialization of the NCSS from a dead start (i.e., no power and memory loss).
- o Special Equipment - all special test equipment and special tools necessary for proper NCSS maintenance and operation.

CONCLUSION

The Interphone/Intercom Service of the FAA has been served since the 1950's by crossbar and relay based switching systems, with hardwired logic, which were then the state-of-the-art. The increasing air traffic and complexity of procedures in serving safe take-offs, landings, and flights, has demanded quicker, more versatile and feasible switching systems. The old systems cannot meet the challenges of aviation communications of the future.

The state-of-the-art in technology has advanced from the relay and crossbar days to computer controlled all solid-state electronics. Today's systems technology offers substantial savings in reduced building space and power requirements, far higher speeds of connections, utmost reliability, low downtime, and instantaneous fault detection location and repairs (through module replacement).

Additionally, systems allow for quick reconfiguration in gaining optimal configuration for utilizing scarce and expensive trained controller resources. These systems can adapt to any new signaling scheme through software, however, the very specific requirements have so far prevented any zealous activity on the part of the industry. The ultimate reliability requirements have been the cause of new hasty actions on the part of the FAA, which did initiate some programs for developing new switching units. These programs were shelved at various levels during conceptualization or development for one reason or another.

The TCSS program did result in the procurement of a Litton exchange, which has been installed at Dallas/Fort Worth. The success of this modern exchange has proved to the FAA that the replacement of other existing systems will be advantageous and timely. The FAA has issued documents and specifications for development and procurement of the switching system to be used at the NAFEC facility, as well as for the Small Voice Switching System (SVSS) to be located at smaller FAA facilities. The existing exchanges at larger FAA facilities will be replaced by two Voice Switching and Control Systems (VSCS), which are still being conceptualized.

Thus, the FAA strategy appears to include a two-tier switching network, a small unit (SVSS), and a large unit (VSCS). Though these two units may be enough to cover most of the spectrum of FAA requirements, it may leave some uncovered range in the middle or lower end of the spectrum.

APPENDIX C REFERENCES

1. FAA Communications Systems Description (1973), Hansen, J.C. et al, FAA Report No. FAA-RD-73-36, February 1973.
2. Overview: The Role of Communication Systems in Air Traffic Management, Roberts, L.W. et al, IEEE Transactions on Communications, Vol. COM 2. No. 5, May 1973.
3. Specifications, for Electric Voice Switching System, DOT/FAA, FAA Publication: FAA-E-2479, June 4, 1971.
4. The National Aviation System Plan Fiscal Years 1976-1985, DOT/FAA FAA Publication 1000.27 App 2, March 1975.
5. Integrated National Airspace Communication System (INACS) For the Support of Air Traffic Control Operations in the 1980's/1990's, DOT/FAA, FAA Publication FAA-INACS-061-221-PD, May 1976.
6. FAA Specifications - ARTCC Interphone Switching Systems, DOT/FAA FAA Publication FAA-S-2010, November 1964.
7. Voice Communication for Air Traffic Control, Ozenberger, M.E. (Bell Laboratories Journal, May 1961).
8. FAA Switching Systems, DOT/FAA (FAA Order: 6470.29, June 1977).
9. Survey of Small Key Telephone Systems, The MITRE Corp./METREK Div., DOT Contract No. DOT-FA78WA-4075/1414B, April 1978.
10. Specifications - Air Traffic Control Interphone Switching System (Intermediate Type - 301A), DA/FAA, FAA Document No. FAA-S-22006a, February 1972.
11. Operational Description of 301A Switching System, ORDER, DOT/FAA, FAA Document No. 6690.1, September 1970.

12. WESCOM System Practices, WESCOM, (Plant Series, Section 920-100, Eqpt. Issue 1, February 1976.
13. FSS TELCO Systems, DOT/FAA, FAA Order N. 6490.1, Chapter 2, Par. 23, September 1977.
14. Test & Evaluation of Dallas/Fort Worth Terminal Communications Switching System, Cleary, R. W. et al, FAA Document No. FAA-NA-75-61, November 1976.
15. Terminal Communication Switching System, Litton AMECOM, Section 1: System Description, (AM011-001-(098), January 1976).
16. The 304 Conference Switching Center, Bidlack, R.H., Bell Laboratories Record, January 1965.
17. Engineering Requirement, Small Voice Switching System, DOT/FAA, FAA Publication No. FAA-ER-220-052, June 1978.
18. Engineering Requirement, NAFEC Communication Switching System (Voice Communication), DOT/FAA, FAA Publication No. FAA-ER-TFE 100, July 1977.

4.
DT