

AD-A126 436

AD-A 126 436

NADC-82186-60



AN ENGINEERING METHOD FOR ESTIMATING
THE AERODYNAMIC CHARACTERISTICS OF
CIRCULATION CONTROL WINGS (CCW)

Campbell Henderson
Aircraft & Crew Systems Technology Directorate
NAVAL AIR DEVELOPMENT CENTER
Warminster, PA 18974

1 JUNE 1982

Final Report
AIRTASK NO. A03V-3200/001B/7F41-400-000

APPROVED FOR PUBLIC RELEASE; DISTRIBUTED UNLIMITED

DTIC QUALITY INSPECTED 3

Prepared For
NAVAL AIR SYSTEMS COMMAND
Dept. of the Navy
Washington, DC 20361

N O T I C E S

REPORT NUMBERING SYSTEM - The numbering of technical project reports issued by the Naval Air Development Center is arranged for specific identification purposes. Each number consists of the Center acronym, the calendar year in which the number was assigned, the sequence number of the report within the specific calendar year, and the official 2-digit correspondence code of the Command Office or the Functional Directorate responsible for the report. For example: Report No. NADC-78015-20 indicates the fifteenth Center report for the year 1978, and prepared by the Systems Directorate. The numerical codes are as follows:

CODE	OFFICE OR DIRECTORATE
00	Commander, Naval Air Development Center
01	Technical Director, Naval Air Development Center
02	Comptroller
10	Directorate Command Projects
20	Systems Directorate
30	Sensors & Avionics Technology Directorate
40	Communication & Navigation Technology Directorate
50	Software Computer Directorate
60	Aircraft & Crew Systems Technology Directorate
70	Planning Assessment Resources
80	Engineering Support Group

PRODUCT ENDORSEMENT - The discussion or instructions concerning commercial products herein do not constitute an endorsement by the Government nor do they convey or imply the license or right to use such products.

APPROVED BY:



T. J. GALLAGHER
CAPT USN

DATE:



20 Jan 1983

REPORT DOCUMENTATION PAGE		READ INSTRUCTIONS BEFORE COMPLETING FORM
1. REPORT NUMBER NADC-82186-60	2. GOVT ACCESSION NO.	3. RECIPIENT'S CATALOG NUMBER
4. TITLE (and Subtitle) An Engineering Method for Estimating the Aero-dynamic Characteristics of Circulation Control Wings (CCW)		5. TYPE OF REPORT & PERIOD COVERED Final
		6. PERFORMING ORG. REPORT NUMBER
7. AUTHOR(s) Campbell Henderson		8. CONTRACT OR GRANT NUMBER(s)
9. PERFORMING ORGANIZATION NAME AND ADDRESS Naval Air Development Center Aircraft & Crew Systems Technology Directorate Warminster, PA 18974		10. PROGRAM ELEMENT, PROJECT, TASK AREA & WORK UNIT NUMBERS
11. CONTROLLING OFFICE NAME AND ADDRESS Naval Air Systems Command Department of the Navy Washington, DC 20361		12. REPORT DATE 1 June 1982
		13. NUMBER OF PAGES 32
14. MONITORING AGENCY NAME & ADDRESS (if different from Controlling Office)		15. SECURITY CLASS. (of this report) Unclassified
		15a. DECLASSIFICATION/DOWNGRADING SCHEDULE
16. DISTRIBUTION STATEMENT (of this Report) Approved for public release; distribution unlimited		
17. DISTRIBUTION STATEMENT (of the abstract entered in Block 20, if different from Report)		
18. SUPPLEMENTARY NOTES		
19. KEY WORDS (Continue on reverse side if necessary and identify by block number) CCW, Circulation Control Wing STOL, Aerodynamics Lift, Drag, Pitching Moment		
20. ABSTRACT (Continue on reverse side if necessary and identify by block number) An engineering method for predicting the aerodynamic characteristics of Circulation Control Wings is presented. The method has been developed from correlations of the available DTNSRDC data base in accordance with theoretical developments of circulation control by slot blowing and modified jet flap theory for finite span effects.		

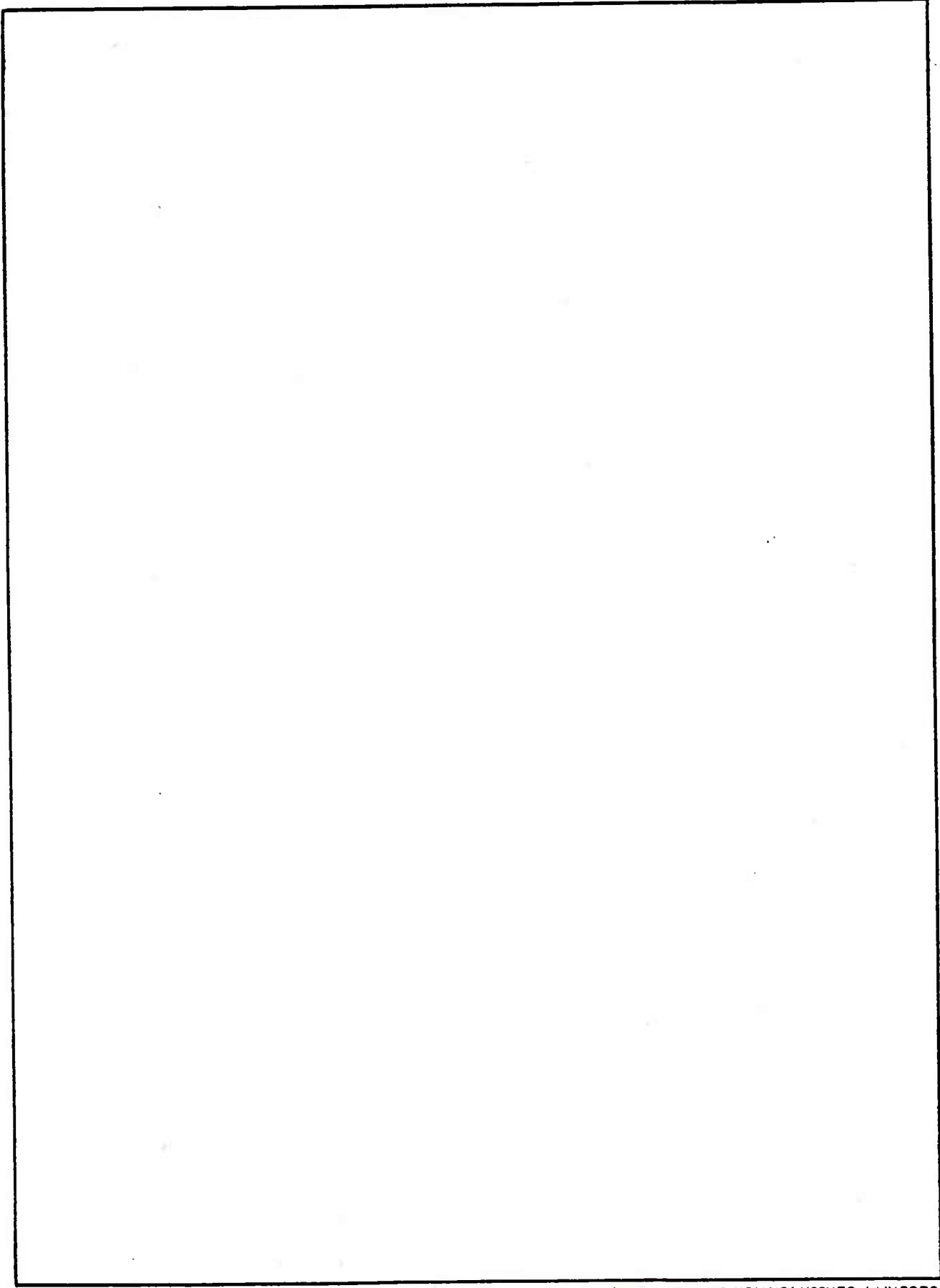

SUMMARY

An engineering method for predicting the aerodynamic characteristics of the Circulation Control Wing is presented. The method has been developed based on correlations of the available David W. Taylor Naval Ship Research and Development Center (DTNSRDC) data base, in accordance with the theoretical basis of circulation control by slot blowing, and the modified theory of the jet flap for finite span effects.

ACKNOWLEDGEMENT

The author wishes to acknowledge the contribution of Mr. R. Englar of DTNSRDC for his assistance in providing all available reference material and his guidance in the development approach used in this study.

NADC-82186-60

(THIS PAGE INTENTIONALLY LEFT BLANK)

T A B L E O F C O N T E N T S

	<u>Page No.</u>
Summary	i
List of Figures	ii
List of Symbols	iii
Introduction	1
Theoretical Basis of Circulation Control	2
Development of Empirical Method	6
Section Lift Curve Slope & C_{lmax}	6
Three Dimensional Correction Factors/Test Comparison	12
Center of Pressure Correlation	14
Drag	19
References	25

L I S T O F F I G U R E S

<u>Figure</u>	<u>Description</u>	<u>Page No.</u>
1	Circulation Control By Slot Blowing	1
2	CCW Airfoils Correlation	7
3	Supercritical CCW Airfoils Correlation	8
4	Comparison of CCW Airfoils	9
5	CCW Airfoils Two Dimentional Lift Curve Slope	10
6	Section Lift of NACA 66-210/CCW	11
7	C_{lmax} and α_{stall} as Functions of Momentum Coefficient . . . and Nose Droop Angle for 66-210/CCW Airfoils	13
8	A-6/CCW Wind Tunnel Model Lift Due to Blowing	15
9	T-2C/CCW Comparison of Wind Tunnel Test With Estimate	16

L I S T O F F I G U R E S (CONTINUED)

<u>Figure</u>	<u>Description</u>	<u>Page No.</u>
10	Two Dimensional CCW Airfoils - Center of Pressure of Lift Due to Blowing	17
11	Two Dimensional Supercritical CCW Airfoils Center of Pressure Correlation	18
12	Thrust Recovery of CCW Airfoils	20
13	Effect of Aspect Ratio and Flap Span on Induced Drag Factor K	22
14	A-6/CCW Drag Due to Lift	23
15	T-2C/CCW Drag Due to Lift	24

L I S T O F S Y M B O L S

<u>Symbol</u>	<u>Description</u>	<u>Units</u>
A	Aspect Ratio	--
b	Wing Span	m (ft)
b'	Distance Between Outboard Ends of Blown Span	m (ft)
b_f	Flap Span	m (ft)
C_{ℓ}	Section Lift Coefficient	--
C_L	3 Dimensional Lift Coefficient	--
$C_{L_{C_{\mu}=0}}$	Lift Coefficient at No Blowing	--
$C_{L_{C_{\mu}}}$	Lift Coefficient Due to Blowing	--
c	Wing Chord	m (ft)
CK_T	Correlation Coefficient	--
C_{μ}	Momentum Coefficient	--
C_D	Drag Coefficient	--
C_{D_i}	Induced Drag Coefficient	--
e	Oswald Efficiency Factor	--

L I S T O F S Y M B O L S

<u>Symbol</u>	<u>Description</u>	<u>Units</u>
F	Three Dimensional Correction Factor	--
F_2	Separation Parameter	--
h	CCW Slot Height	cm (in)
K, K_1 , K_2 , K_3 , K_4	Correlation Constants	--
λ	Logarithmic Reynolds Number, ref 2,	--
r	CCW Cylinder Radius	cm (in)
R_m	Boundary Layer Reynolds Number, ref 2,	--
R_e	Free Stream Reynolds Number Based on Chord	--
s_w	Wing Reference Area	m (ft)
s	Surface Distance Around Cylinder	cm (in)
t	Wing Thickness	cm (in)
u	Ratio of Local Velocity Outside B.L. to Freestream Velocity	--
V_j	Jet Velocity	m/sec (ft/sec)
V_∞	Free Stream Velocity	m/sec (ft/sec)
X_{cp}	Center of Pressure Location	m (ft)
Z_E	Boundary Layer Shape Factor	--

G R E E K S Y M B O L S

<u>Symbol</u>	<u>Description</u>	<u>Units</u>
α	Angle of Attack, Correlation Exponent	deg
β	Correlation Exponent	cm (in)
δ	Boundary Layer Thickness	cm (in)
δ_2	Boundary Layer Momentum Thickness	cm (in)
ξ	Ratio of Distance From Wall to Boundary Layer Thickness	--
γ	Correlation Exponent	--
θ	Flow Turning Angle Around Cylinder	rad
θ_s	Flow Turning Angle at Separation	rad

I N T R O D U C T I O N

The NAVAIRDEVGEN has been developing a V/STOL Aerodynamics/Stability & Control Manual, reference 1, applicable to a range of V/STOL concepts. That effort has been expanded to include prediction methods for the various high-lift STOL aircraft concepts. Although as in all aircraft design developments detailed testing will play a major role, it is beneficial at the early design stage of future applications to have engineering prediction methods to study the design and concept trade-offs.

This report presents results of a semi-empirical prediction technique development for the general class of Circulation Control Wing (CCW) STOL Aircraft. The application of circulation control for high lift by tangential blowing over the bluff trailing edge of airfoils has been carried out principally by the DTNSRDC beginning in the late 1960's. A large body of two dimensional airfoil data has been built up with subsequent extension to three dimensional models and finally to full scale flight demonstrator aircraft. The CCW capability was recently successfully proven in the Grumman A-6/CCW demonstrator vehicle. Development of a V/STOL Manual/DATCOM type of engineering prediction technique is made possible by the extensive DTNSRDC data base. The approach taken through discussion with R. Englar of DTNSRDC was to correlate all available two dimensional CCW data with appropriate geometric and flow variables. The resulting charts will permit empirical prediction of 2D lift, drag and moment characteristics of candidate airfoils. Predictions of the complete 3D CCW system, normally having partial span blowing, then employs application of three dimensional factors, verified through comparisons with complete vehicle model tests.

The basic approach used to develop the semi-empirical method for the prediction of longitudinal aerodynamic characteristics of Circulation Control Wing STOL aircraft is summarized as follows:

- 1) The theoretical basis of Circulation Control was studied to establish the fundamental geometric and flow parameters and their relationships which govern super circulation lift.
- 2) The body of experimental data on two dimensional airfoils was correlated against the driving parameters to establish the correlative coefficients and exponents of all test airfoils.
- 3) Three dimensionalizing factors of a modified jet flap theory were applied and comparisons made with available 3 D CCW data.

Theoretical Basis of Circulation Control

The theoretical basis of Circulation Control was examined to determine the parametric relationships governing CCW high lift as a means to guide the data correlations for development of an empirical prediction technique.

A well developed theoretical basis of Circulation Control was conducted by Dunham, reference 2, applied to a circular cylinder having tangential blowing over the upper surface to delay aft-upper surface separation. Figure 1 shows the system considered. A relatively small amount of slot air is used which in principle only re-energizes the boundary layer. This effect is used to increase lift and reduce drag. In contrast, a jet flap requires much more blowing air and generates thrust as well as lift.

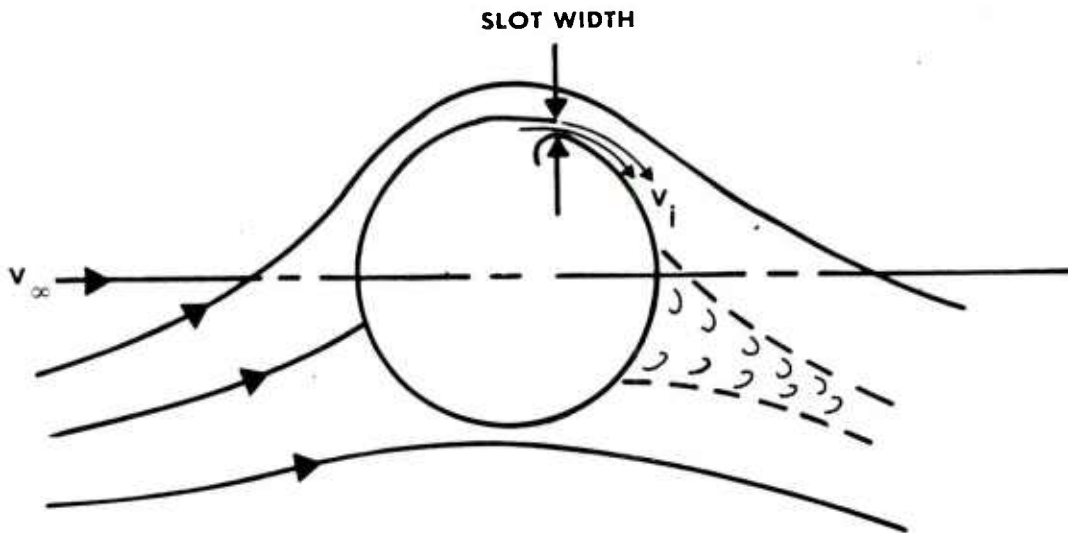

FIGURE 1. Circulation Control

The circulation around an airfoil with a sharp trailing edge is fixed by the Kutta-Joukowski condition. With a rounded trailing edge however it has been shown that this condition is replaced by the condition that upper and lower surface separation occurs at the same surface pressure. Thus circulation is increased when separation on the upper surface is delayed. The ability to move the rear stagnation point downstream and thus increase circulation lift, is maximized by choosing a circular cylinder. The essence of the theoretical method is the calculation of the boundary layer around the cylinder until a separation criteria is satisfied. Spalding's theory, as modified for wall jet flow, reference 2, was used by Dunham to calculate the turbulent boundary layer to the separation point. The Spalding Velocity profile includes boundary layers with a wall-jet as well as without one. Spalding assumes a boundary layer profile defined as:

$$z = \frac{\text{local velocity within the boundary layer}}{\text{local velocity just outside the B.L.}}$$

$$= \frac{z_e}{\ell} \ln \xi + z_e + 1/2 (1 - z_e) (1 - \cos \pi \xi)$$
(1)

where $\xi = \frac{\text{distance from wall}}{\text{boundary layer thickness}}$

The parameter z_e is a shape factor illustrated below, encompassing the normal boundary layer as well as boundary layers with tangential (wall-jet) blowing. z_e is also proportional to the wall-jet to free stream velocity ratio i.e., $z_e = k \left(\frac{V_j}{V_\infty} \right)$

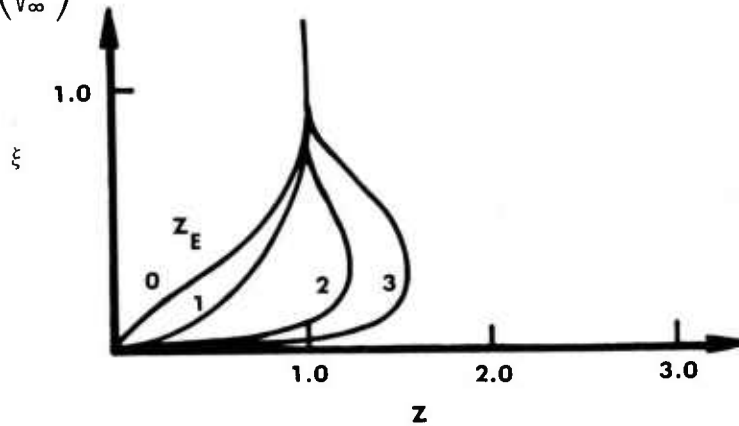

BOUNDARY LAYER PROFILES

The factor ℓ in equation (1) is a logarithmic Reynolds Number given by:

$$\ell = \ln \frac{2.6168 R_m z_e}{.5\ell (1 + z_e) - z_e}$$
(2)

where R_m is the boundary layer Reynolds number given by:

$$R_m = I_1 \left(\frac{\delta}{c} \right) u Re = \frac{I_1}{I_1 - I_2} \left(\frac{\delta_2}{c} \right) u Re$$
(3)

in which δ = boundary layer thickness
 δ_2 = boundary layer momentum thickness
 $u = \frac{\text{local velocity outside B.L.}}{\text{free stream velocity}}$

R_e = Free stream Reynold number based on chord

I_1 & $I_2 = f(Z_e)$ given in reference 2.

At a slot, the existing boundary layer meets the wall-jet and for perhaps six slot widths downstream the profile cannot conform to Spalding's assumption. However, if the circulation control is working, separation does not occur there so the following procedure was adopted. The mass flow in the boundary layer was assumed to be the sum of the existing boundary layer mass flow plus the wall-jet flow.

A pressure gradient separation parameter introduced earlier by Spalding was then used in the form:

$$F_2 = \frac{\delta_2}{u} c \frac{du}{ds}; \text{ in which } \delta_2 = \delta(I_1 - I_2) \text{ and} \quad (4)$$

s = surface dist.

and a separation criteria due to Stratford was modified to give:

$$(F_2)_{\text{sep}} = -.06 Z_e^2 (I_1 - I_2) \quad (5)$$

This criteria can be applied both to boundary layer flow and wall-jet flow. Sample calculations for a blown circular cylinder gave the typical Z_e and λ values from which the above separation criteria was determined.

Thus separation occurs when:

$$F_2 = (F_2)_{\text{sep}}$$

Combining equations 3, 4, & 5 and relating terms to the CCW gives:

$$-.03 Z_e^2 I_1 = \frac{R_m}{R_e} \frac{1}{u^2} \frac{du}{d(s/r)} \quad (6)$$

in which r = CCW radius

Dunham modified the entrainment law for jet flow ($Z_e > 1$) to account for wall-jet curvature leading to an expression for dR_m/ds applicable for all $Z_e > 1$ (reference 2). Then considering that $Z_e \sim \left(\frac{V_j}{V_\infty}\right)$ and that the decay of a wall-jet from reference 3 is of the form:

$$\frac{(V_j/V_\infty)}{K (s/h)^n} = (V_j/V_\infty)_0 \quad \text{where } h = \text{slot height,} \\ s = \text{wall-jet surface distance} \quad (7)$$

valid for $K\left(\frac{s}{h}\right)^n \geq 1.0$

and assuming that the exterior flow remains essentially potential until separation at the angle θ around the cylinder or:

$$u = u_0 \cos K_1 \theta \quad (8)$$

where θ is measured from the CCW slot position.

By substituting in Equation (6) and simplifying terms, it can be shown that the form of the solution at separation is:

$$f(\theta)_{\text{sep}} = \frac{K_1 \left(\frac{V_j}{V_\infty}\right)^\alpha \left(\frac{h}{r}\right)^\beta}{(\delta/c + K_2)} \quad (9)$$

Since circulation lift is proportional to θ_{sep} or $C_L \sim \theta_S (r/c)$, then:

$$C_L \sim \frac{K_3 \left(\frac{V_j}{V_\infty}\right)^\alpha \left(\frac{h}{r}\right)^\beta \left(\frac{r}{c}\right)^\gamma}{K_4 (\delta/c + 1)} \quad (10)$$

The major driving parameters for increased C_L are thus seen to be $(V_j/V_\infty)_0$, (h/r) and (r/c) with as yet undetermined exponents.

The denominator factor (δ/c) is the boundary layer thickness at the CCW slot and for the turbulent flow is of the form $\delta/c = \frac{K}{Re^{1/5}}$. Thus C_L is also a weak function of Reynolds Number i.e. Increasing Reynolds Number weakly increases C_L .

The equation (10) provided insight for the subsequent 2 D data correlations to determine the best form for data collapse.

Development of Empirical Method for 2D Lift

The DTNSRDC experimental data on two dimensional airfoils, reference 4 through 7, was then used in the empirical analysis to determine the parameters and exponents that provide acceptable correlations of the test data. It was the general form of the relationship for 2 D C_l shown in the previous section, equation (10) that provided the most acceptable data fit. CCW airfoil data for the state-of-the-art airfoils as well as for some of the earlier lower thickness ratio, t/c , elliptic airfoils (considered for CCR applications) are shown correlated in Figure 2 against the parameter:

$$C_{KT} = (V_j/V_\infty) \left(\frac{h}{r}\right)^{1/3} (r/c)^{1/2}$$

The data correlates with this parameter within an accuracy of approximately $\pm 10\%$. The section lift coefficient plotted, ΔC_l , is actually the incremental lift due to blowing obtained from tests as $-\Delta C_l = (C_{l_{c_\mu}} - C_{l_{c_\mu=0}})$

One set of test data (starred) for the pure ellipse did not initially correlate, however it was reasoned that in this case the CCW slot flow had traversed a distance $\Delta X/h$ before reaching the cylindrical turn. The jet had grown and decayed to new initial conditions. By using the new initial jet conditions at the turn, estimated based upon wall-jet growth and decay characteristics of reference 3 as the parameters in the coefficient C_{KT} , good correlation was obtained. It may be inferred from this that there is no advantage aerodynamically in placing the slot more forward than the start of the cylindrical turn.

An important condition to be noted in the data shown in Figure 2 is that the test data used was obtained with airfoils having a leading edge device which was extended to prevent leading edge separation; particularly at the higher ΔC_l values.

A similar correlation to the above was carried out for the supercritical CCW airfoils data from reference 6. The results are shown in Figure 3. The data-collapse is not as good as in the previous figure however, it generally falls within about $\pm 12\%$ of a mean correlation line. A leading edge device was not used on these models since the generous L.E. radius of the 17% thick supercritical airfoils was less prone to separation. A comparison of the two sets of airfoil data, state-of-the-art and supercritical (mean line), are also shown in Figure 4, and indicate similar correlative trends.

Section Lift Curve Slope and $C_{l_{max}}$

The available 2D test data on angle of attack effects indicates that CCW blowing has a quite small effect on section lift curve slope. The departure from the standard unmodified airfoil slope due to the cylindrical trailing edge appears to be very little at no blowing, and to have either zero or a slight increase with increased blowing. Representative test results for three airfoils are shown in Figure 5 and the variations of C_l with α over the C_μ range for the NACA 66-210 are shown in Figure 6. No consistent geometrical or flow property correlations with these small changes could be deduced; and further, the differences from the unmodified airfoil are probably within the accuracy of three dimensionalizing factors to be applied due to aspect ratio and partial span blowing. Thus a conservative first guess at section slope would be the basic unmodified airfoil characteristics.

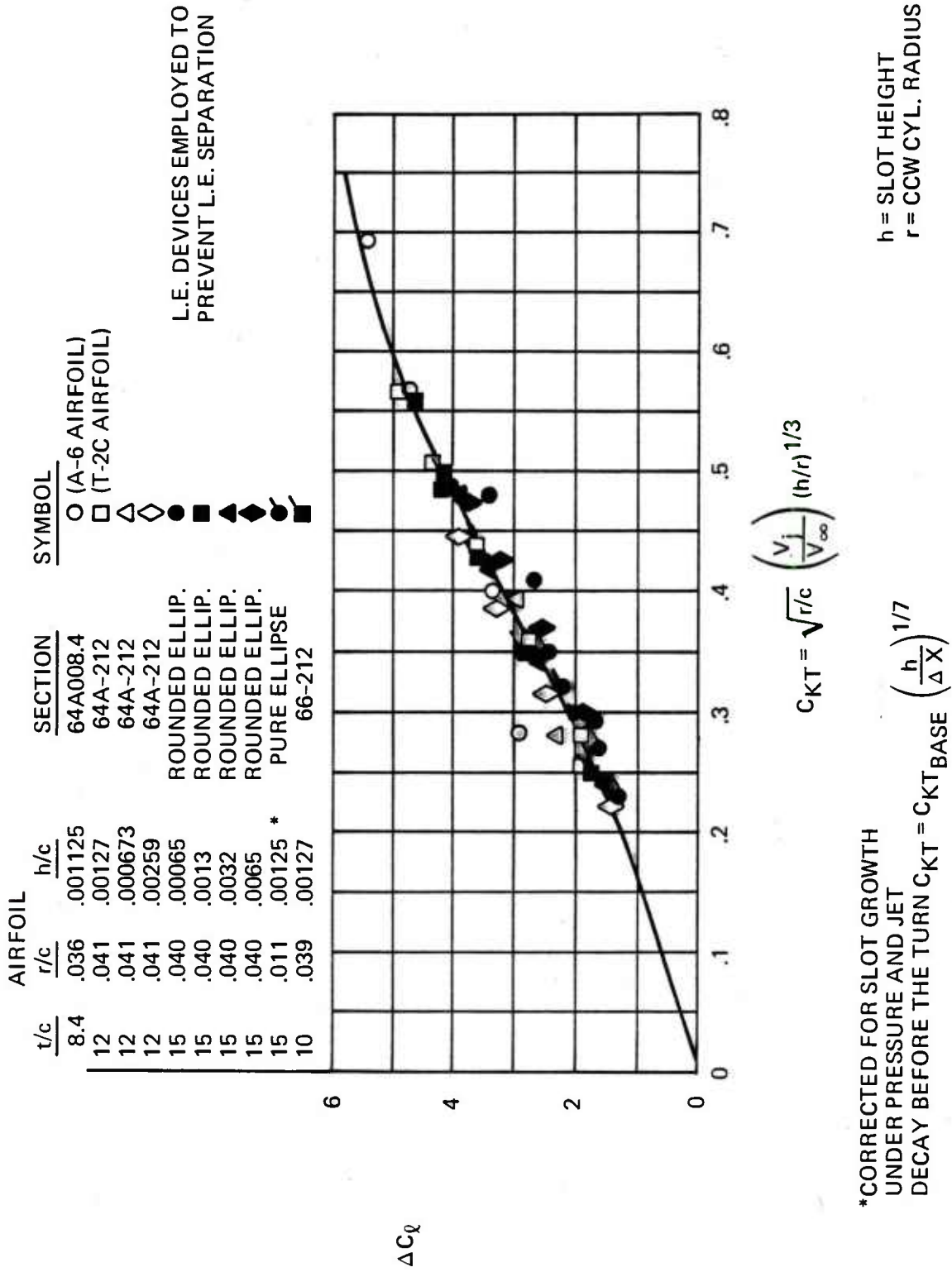

FIGURE 2. CCW Airfoils Correlation

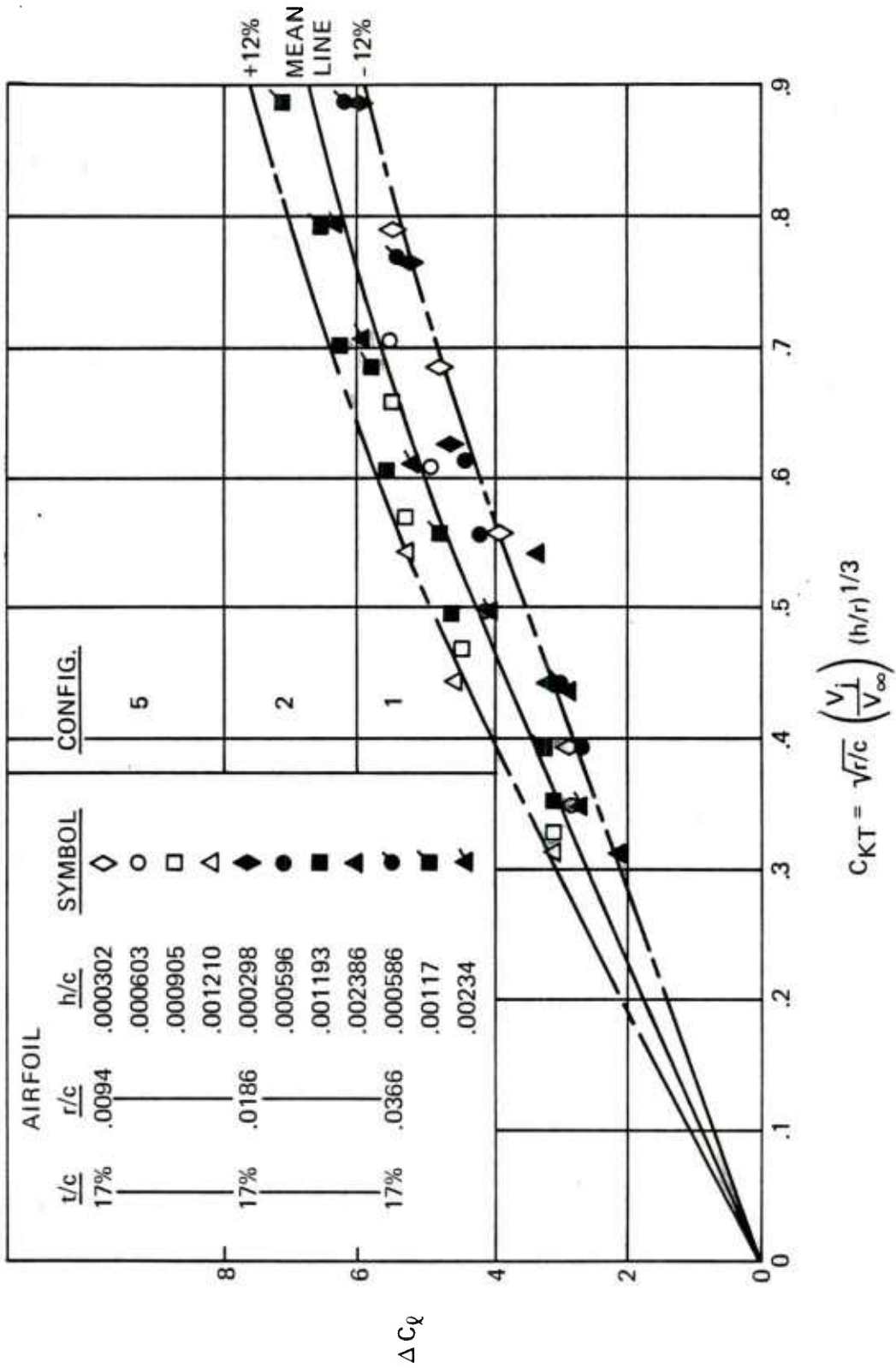

FIGURE 3. Supercritical Airfoils Correlation

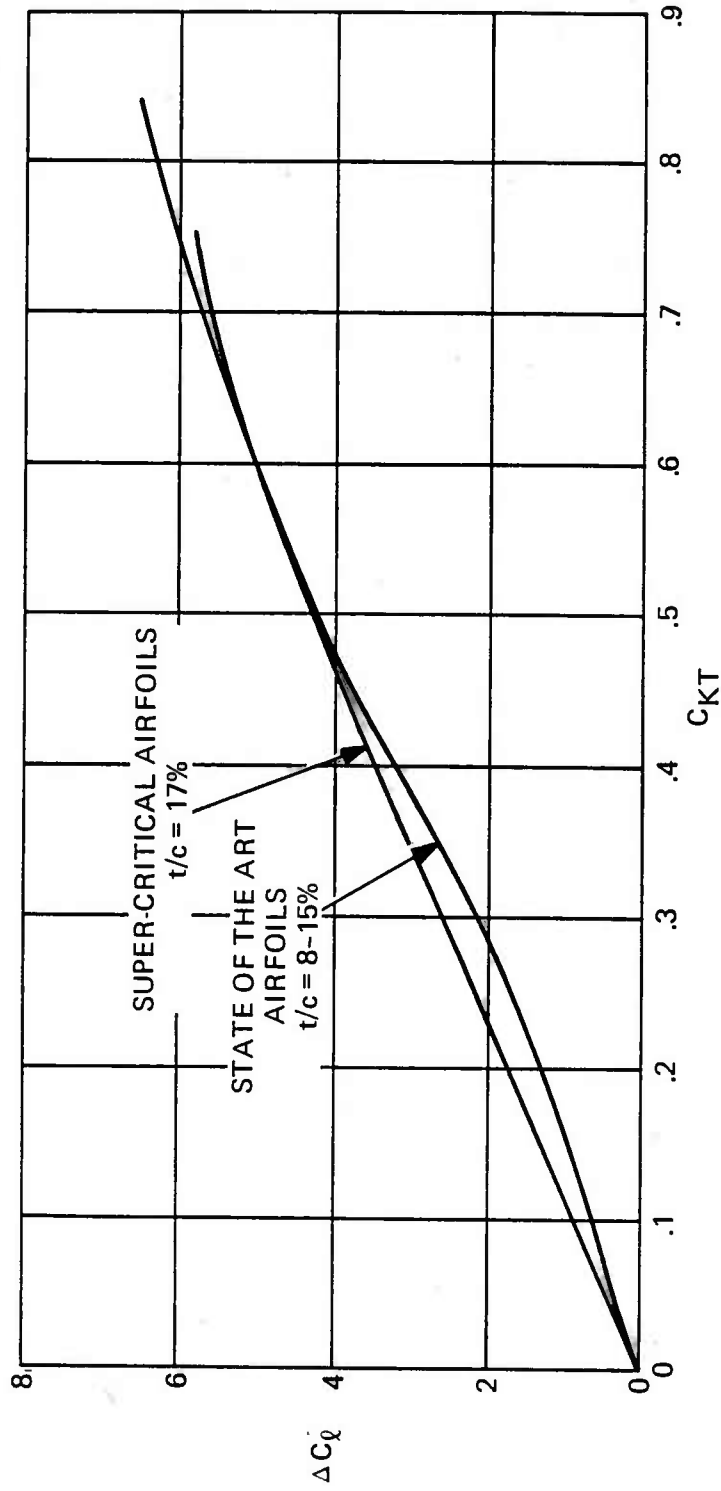

FIGURE 4. Comparison of CCW Airfoils

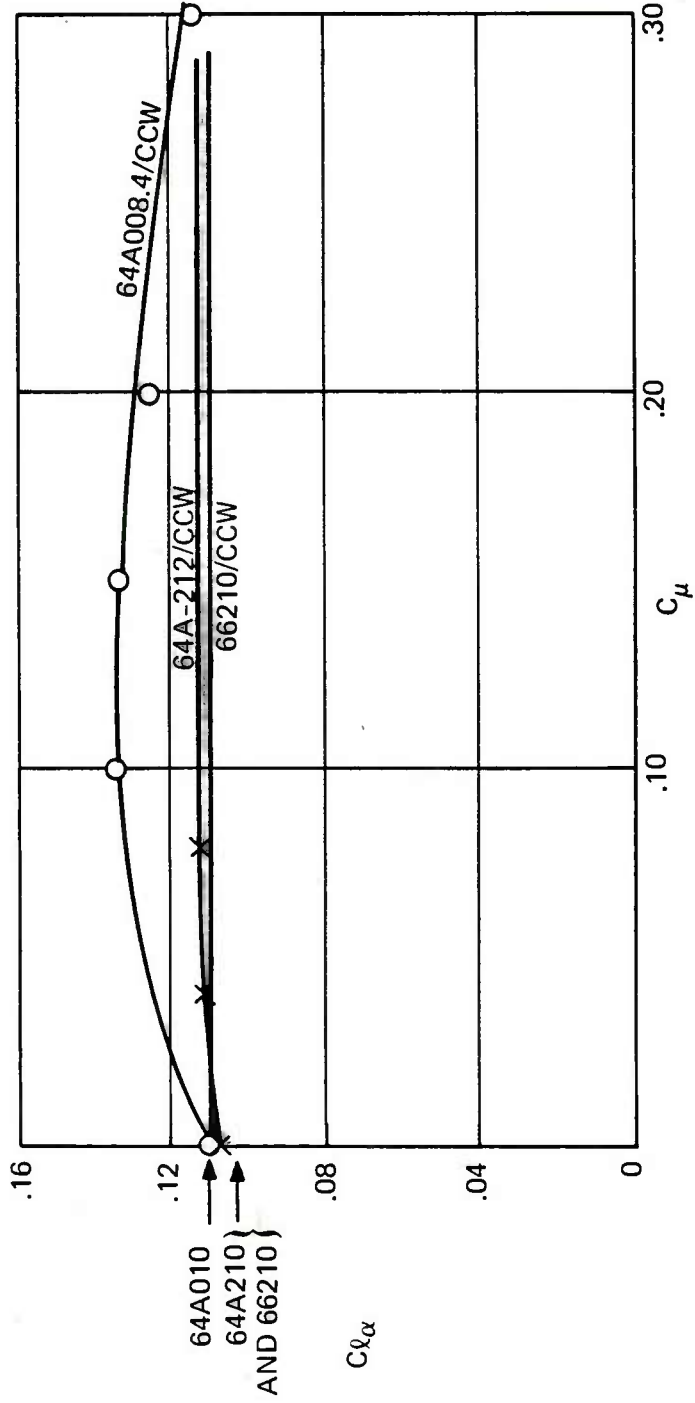

FIGURE 5. Two Dimensional Lift Curve Slope Comparisons

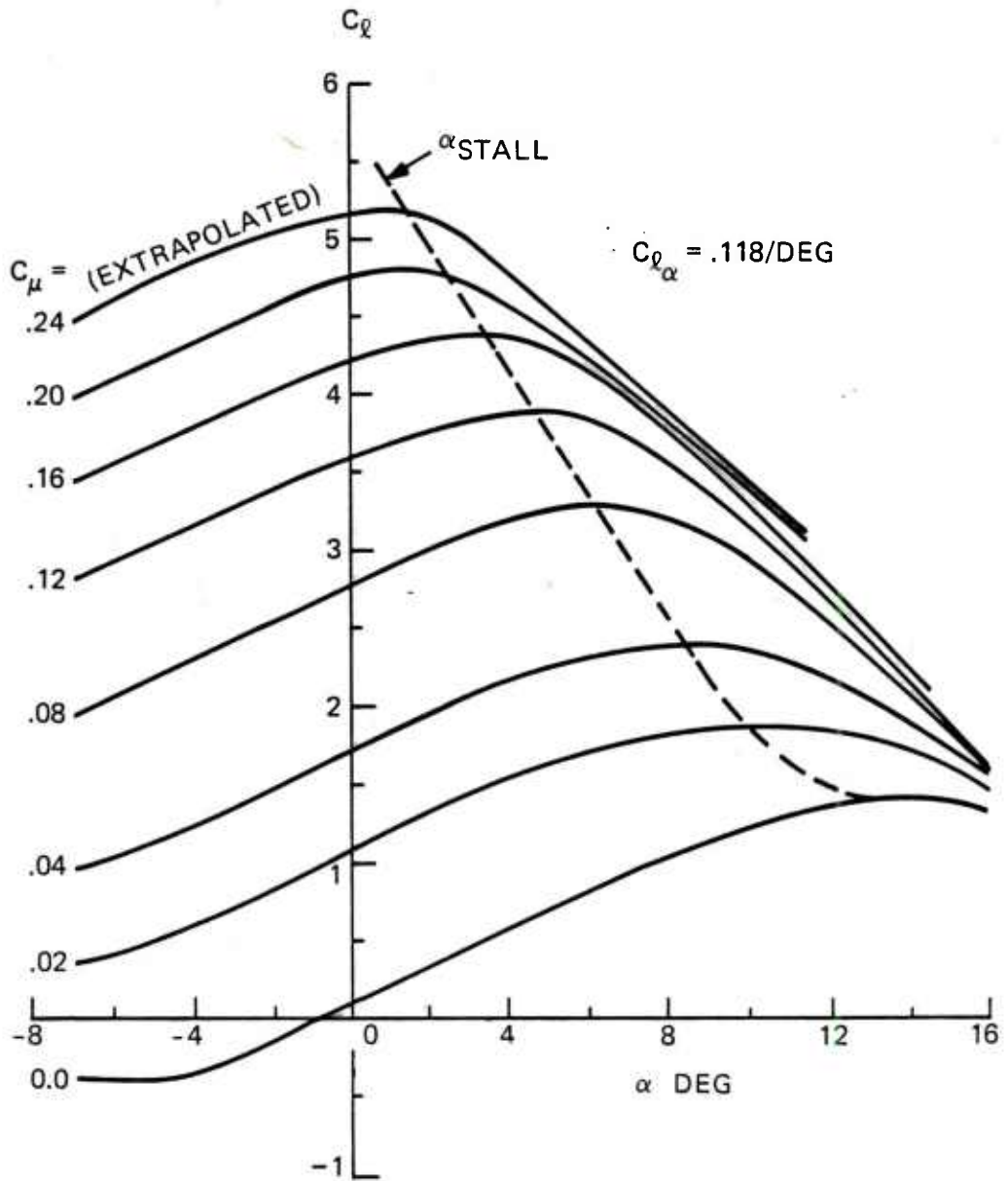

FIGURE 6. Section Lift of NACA 66-210/CCW Airfoil (Reference 5)

The important effects on $C_{l_{max}}$ however need to be carefully considered at the early design selection stage. An insight into the importance of leading edge treatment is afforded by the effect of airfoil nose droop on the 66-210/CCW airfoils shown in Figure 7. Superimposed on the figure are $C_{l_{max}}$ values for the 17% thick supercritical airfoil, configuration 6, of reference 6. The more generous leading edge radius of the thicker supercritical airfoils are as effective in delaying leading edge separation as nose droop angles exceeding about 30° on the state-of-the-art NACA airfoil. A separate study would be needed to develop geometric and flow parameters correlations to predict stall angles of attack and $C_{l_{max}}$ of these diverse CCW airfoils with alternative leading edge treatment devices. A further array of model tests would probably also be required for this purpose.

Three Dimensional Correction Factors/Test Comparisons

The three dimensional factors to be applied to the CCW 2D airfoil powered-lift results are those developed by Maskall and Spence for jet flap wings, reference 8. The factor F which accounts for aspect ratio and blowing quantity is:

$$F = \frac{A + 2 C_{\mu}/\pi}{A + 2 + .604 (C_{\mu})^{.5} + .876 C_{\mu}}$$

Reference 9 provides additional corrections for part span blowing and wing thickness ratio:

$$\lambda = s^1/s_w = \frac{\text{wing area affected by blowing}}{\text{wing reference area}}$$

$$v = s^1 \partial C_{\ell} / \partial \alpha + (s - s^1) (\partial C_{\ell} / \partial \alpha)_{c_{\mu}=0} / s_w (\partial C_{\ell} / \partial \alpha)$$

and the thickness parameter $(1 + t/c)$

The equation to convert from section lift to three dimensional lift becomes:

$$C_L = (1 + t/c) F \left[\lambda (C_{\ell})_{\alpha=0} + v C_{\ell} \alpha \right] + (C_L)_{\alpha=0}$$

Utilizing the 1/8.5 scale A-6/CCW wind tunnel model geometry of reference 10, predictions of blowing lift were made employing the foregoing 2 D correlations and 3 D adjustment factors.

Model parameters used in the analysis are:

$$h/c = .001125$$

$$r/c = .03646$$

$$S_{wing} = 7.32 \text{ ft}^2, s^1 = 5.4 \text{ ft}^2, t/c = .08$$

$$\text{blown span } b^1 = 4.1 \text{ ft}, b_{tot} = 6.23 \text{ ft.}$$

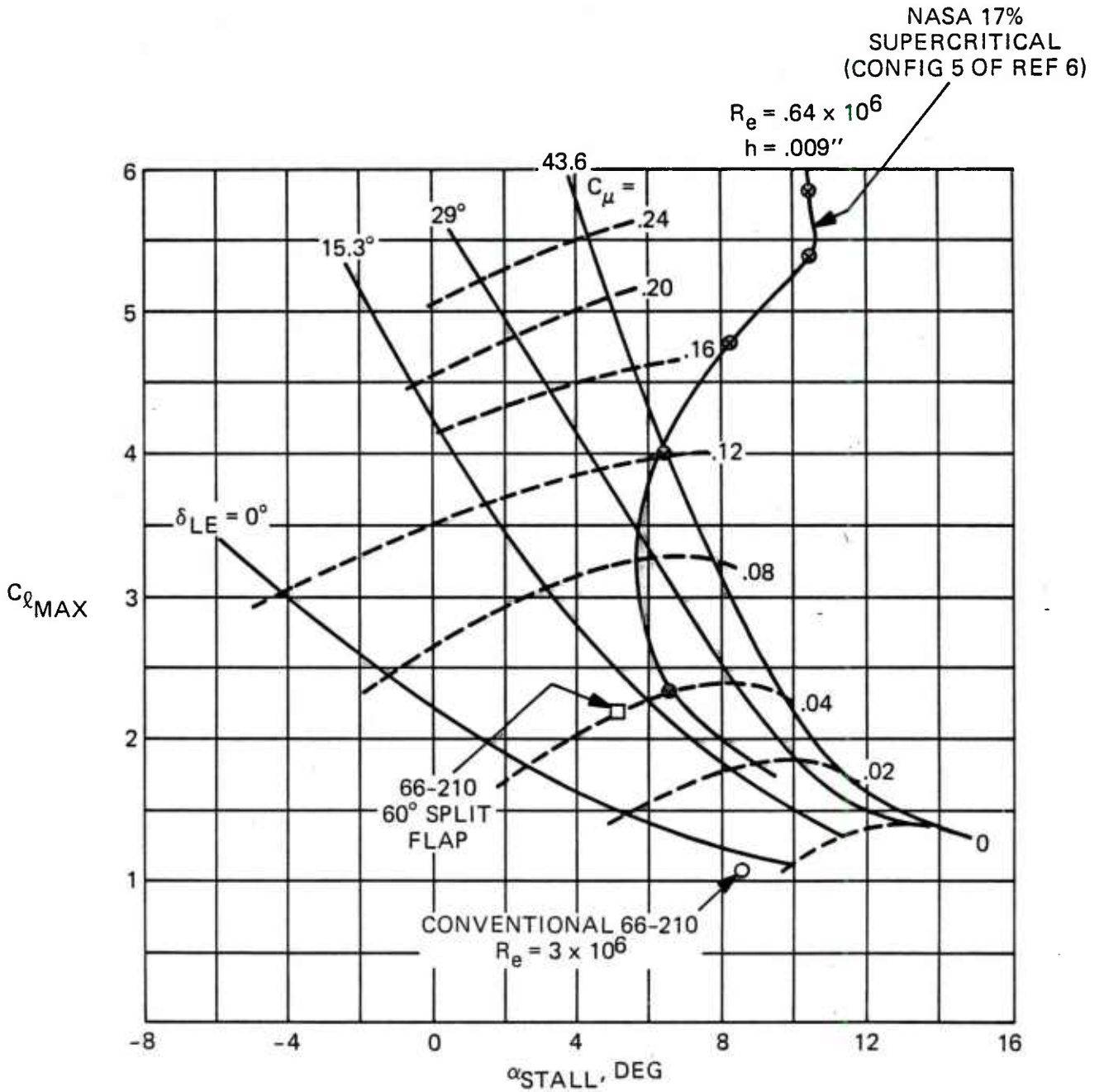

FIGURE 7. Maximum Lift and α_{stall} As Functions of Nose Droop Angle For 66-210/CCW Airfoils

The predicted three dimensional airfoil lift values $(C_L)_{\alpha=0}$ at each C_{μ} when added to the unpowered test value of $(C_L)_{C_{\mu}=0}$ at $\alpha=0$, are plotted in Figure 8. Results are compared with the model test values for the tail-off configuration and show good agreement. The tail increments, yet to be included, can be obtained from standard power-off techniques in DATCOM but must include the power-on downwash effects due to CCW blowing. Estimates of tailplane downwash, due to blowing are not available and will require a separate development, probably encompassing various classes of distributed jet high-lift systems.

A similar analysis was conducted for the T-2C/CCW 1/5 scale wind tunnel model of reference 11. Again the estimated lift coefficient due to blowing when added to the power-off increment, Figure 9, shows good agreement with test results, thus indicating that the 3 D jet flap correction factors described earlier perform well for the CCW blowing system.

Center of Pressure Correlations

The center of pressure location of lift due to blowing was also determined from the available 2 D lift and pitching moments data. Results for the state-of-the-art airfoils are shown in Figure 10 and for the supercritical airfoils in Figure 11. Nearly all of the data falls within about $\pm .05C$ of the 55 percent chord location as shown. Therefore a reasonable empirical estimate of the airfoil pitching moments due to blowing lift can be made as:

$$(\Delta C_m)_{C_{\mu}} = -.55 \Delta C_{\ell} C_{\mu}$$

Note that these results apply to the increments in lift and pitching moment due to blowing, C_{μ} . The lift and moment values at no blowing $C_{\ell} C_{\mu} = 0$, and $C_m C_{\mu} = 0$ which are to be added, are readily obtained from section 4.1 of DATCOM.

The 0.55C center of pressure location was applied to the blown portion of the A-6/CCW and T-2C/CCW models and converted to a C.P. location in percent of M.A.C. and compared with test measurements. Results are shown in the following table.

	<u>3D. TEST</u>	<u>BASED ON 2D. CORRELATION (.55C)</u>
	$\left(\frac{x_{cp}}{c_w}\right)$	$\left(\frac{x_{cp}}{c_w}\right)$
A-6/CCW	.63	.53
T-2C/CCW	.54	.50

The reason that the 3D test results are 5 to 10% aft of the 2D predicted results is not clear, however it may be due to a carryover type loading occurring on the outboard unblown span at a more aft location. In general, however, a x_{cp} location of .55C is considered a reasonable estimate at the early design stage.

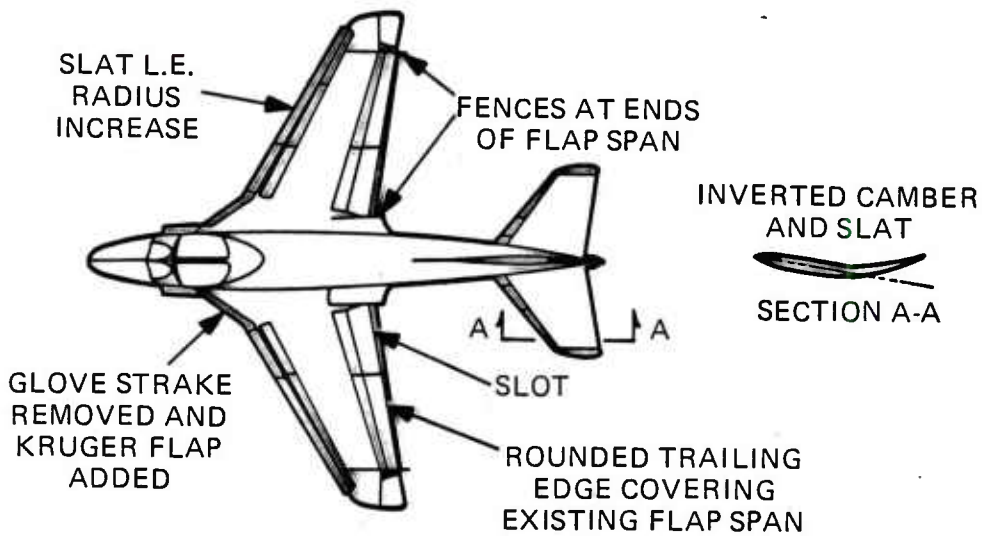
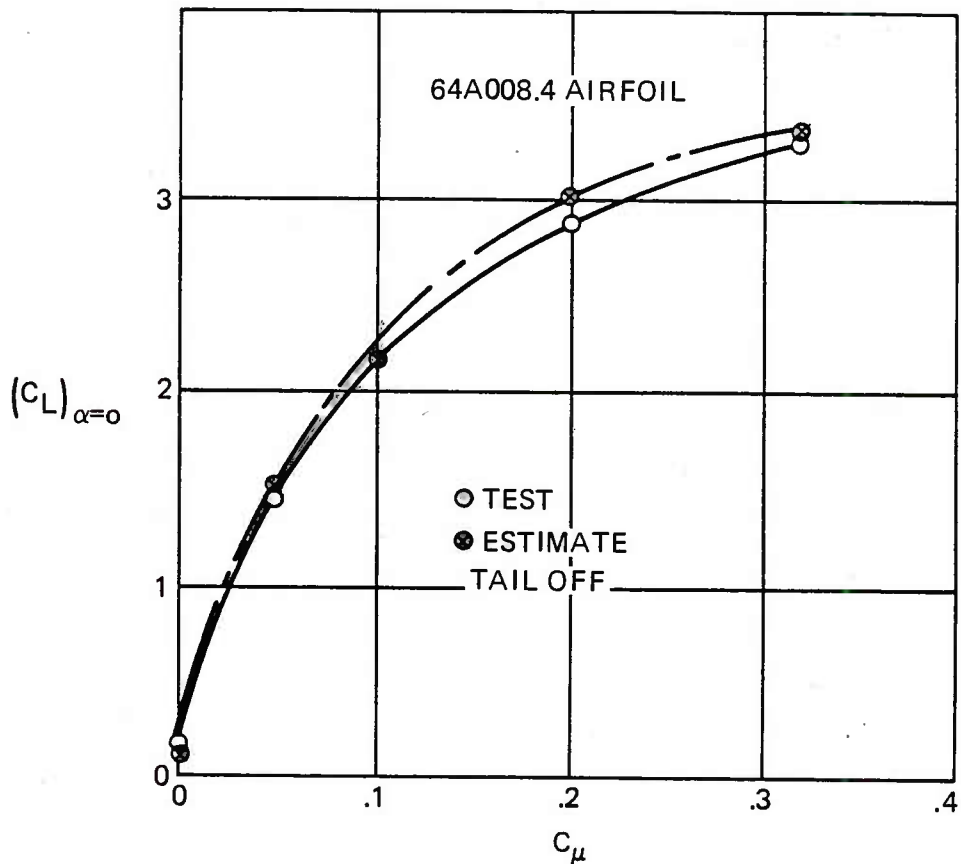

A-6/CCW WING AND TAIL

FIGURE 8. A-6/CCW Wind Tunnel Model Lift Due To Blowing

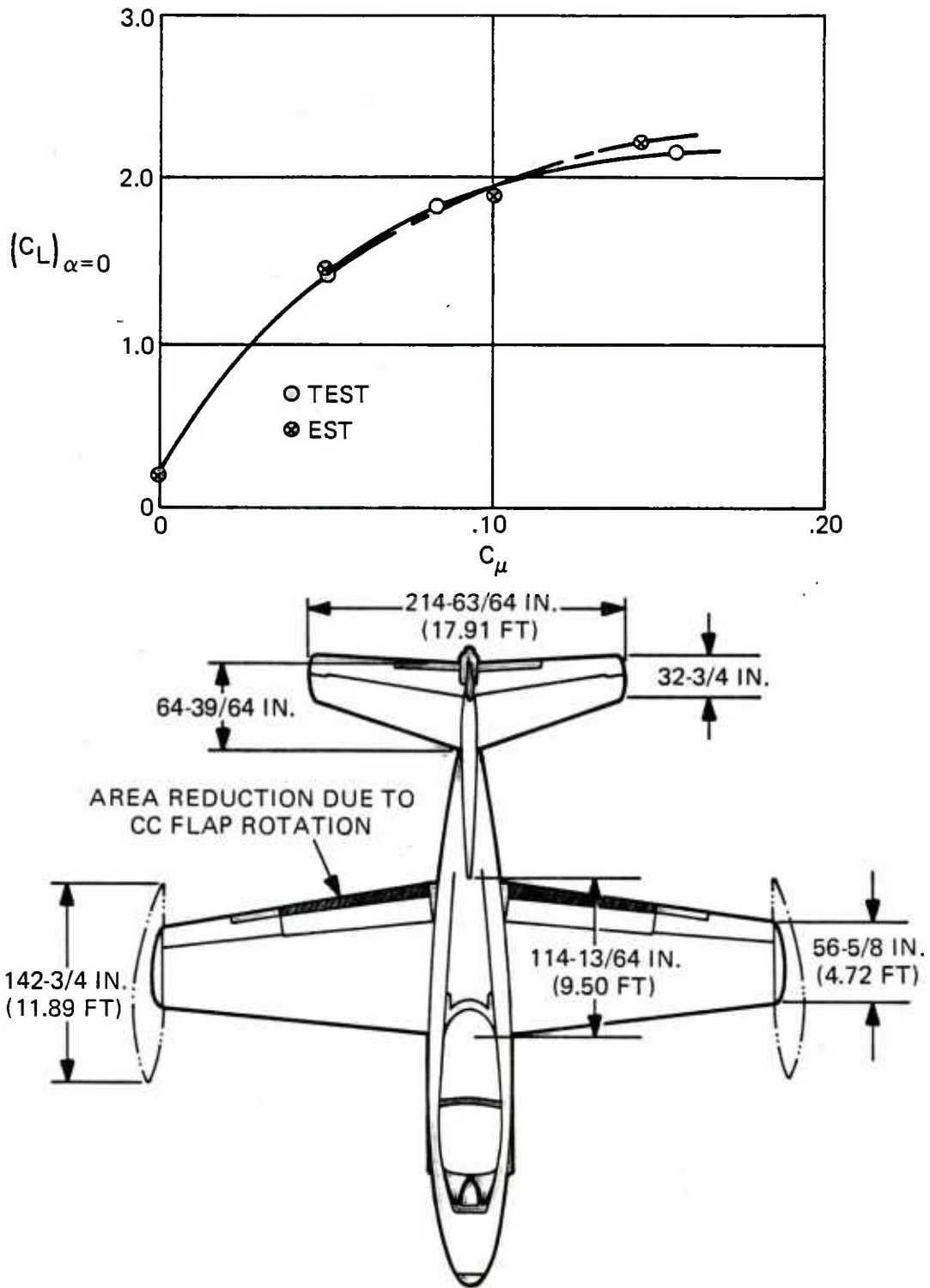

FIGURE 9. T-2/CCW Wind Tunnel Model Life Due To Blowing

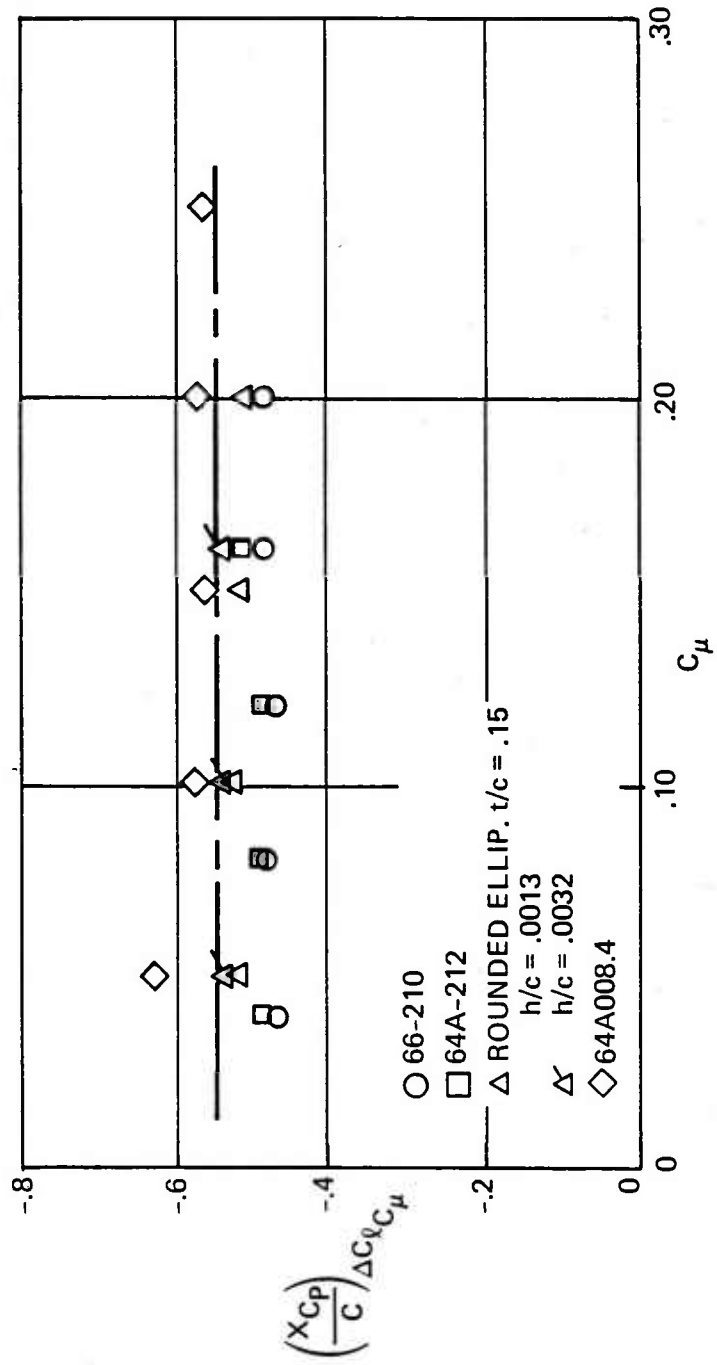

FIGURE 10. 2D CCW Airfoils — Center Of Pressure Of Lift Due To Blowing

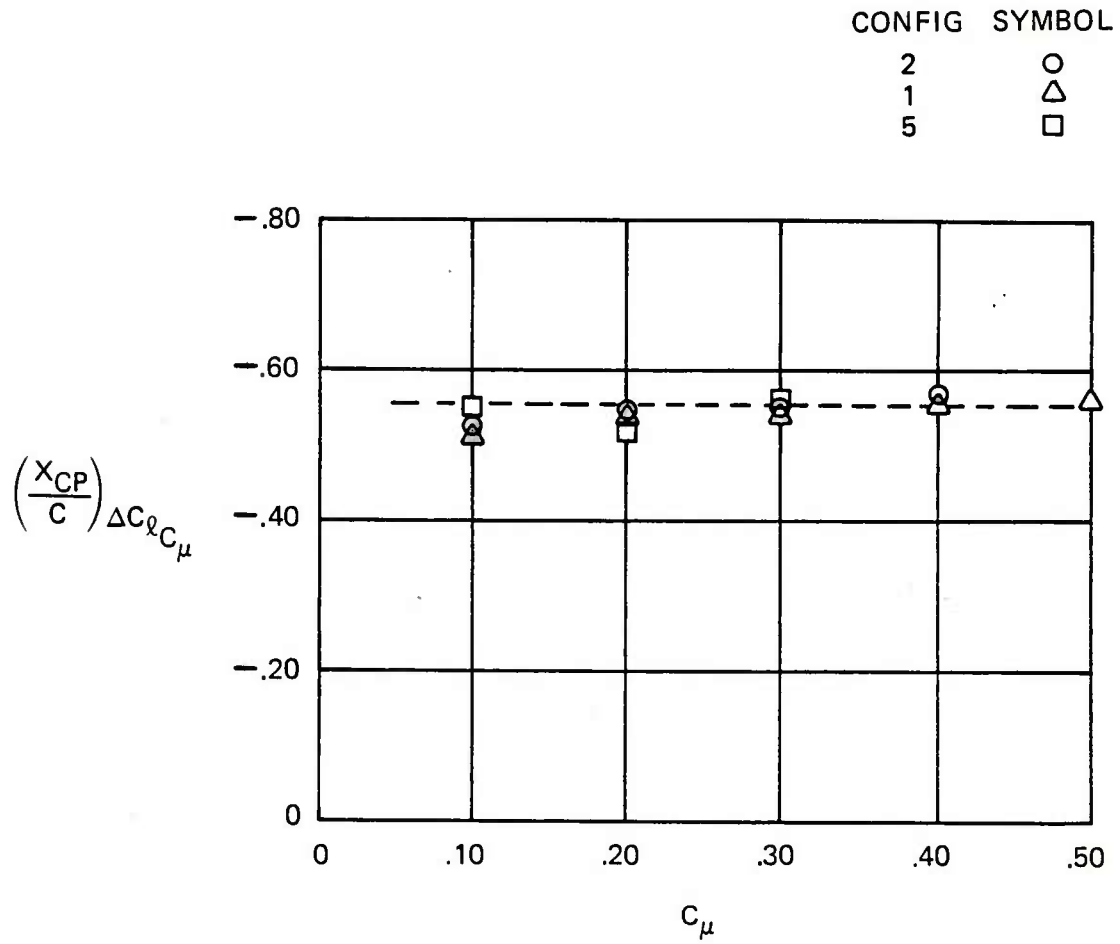

FIGURE 11. 2D Supercritical CCW Airfoils Center Of Pressure Correlation

Drag

Drag characteristics of the CCW system consists of 1) a baseline power-off minimum drag, $C_{D_{MIN}}$, which is slightly higher than the unmodified airfoil drag due to the rounded trailing edge, 2) a thrust recovery (negative) drag increment due to the recovered jet momentum, $\partial C_D / \partial c_\mu$ and 3) a drag due to lift term $K C_L^2$ which depends upon span loading characteristics. The general equation can be written:

$$C_D = C_{D_{MINB}} + (\Delta C_D)_{c_\mu=0} + \frac{\partial C_D}{\partial c_\mu} c_\mu + C_{D_i}$$

where $C_{D_{MINB}}$ = Minimum drag of unmodified wing
 $(\Delta C_D)_{c_\mu=0}$ Drag increment of CCW trailing edge } $C_{D_{MIN}}$

$(\partial C_D / \partial c_\mu)$ = thrust recovery term

C_{D_i} = drag due to lift of the form $K (C_L - C_{L_0})^2$

The factor K is actually a composite of drag due to partial span blowing circulation lift and the more uniform lift due to angle of attack.

The incremental drag, $\Delta C_{D_{c_\mu=0}}$, due to the modified trailing edge is generally small and must be treated on an individual design basis. It is not strictly a drag penalty in the powered lift mode since a conventional flap would add a greater drag penalty, however it does introduce a penalty to the conventional flight cruise mode drag. Representative values from the 2 D airfoil tests are listed in the table below:

<u>AIRFOIL</u>	<u>r/c</u>	<u>$(\Delta C_D)_{c_\mu=0}$</u>
Supercritical Configuration 5, Reference 6	.0094	+0.002
Supercritical Configuration 1, Reference 6	.0366	+0.010
NACA 66210	.0390	+0.012

Thrust Recovery

Values of thrust recovery for several of the 2D airfoils are plotted in Figure 12 against the parameter h/r. The recovery factor can range from about .3 to .8 as shown. At high lift the recovery term is small compared to drag due to lift and in fact, as noted, is overcome by local separations for c_μ greater than about 0.10. At lower blowing values, however it is favorable and will help to offset the penalty due to the blunt trailing edge of CCW airfoils.

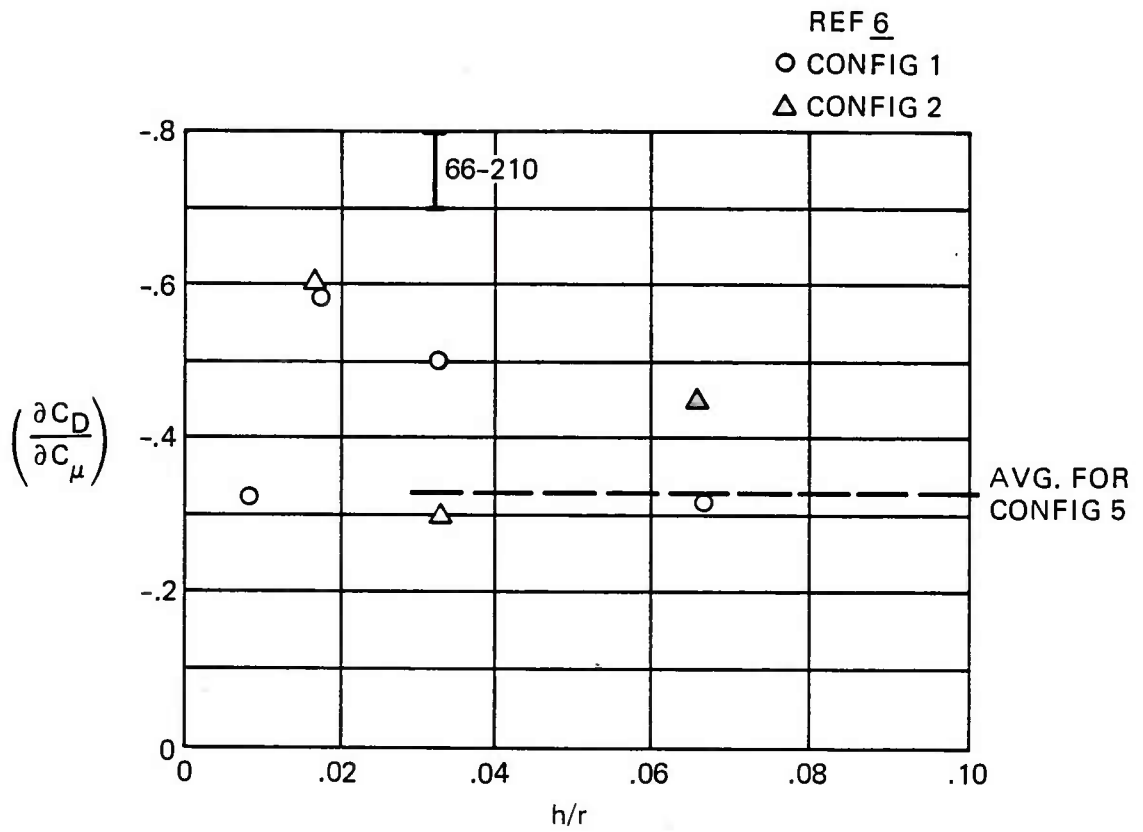

FIGURE 12. Thrust Recovery Of CCW Airfoils

Drag Due to Lift

The drag due to lift generally conforms with the wing/flap theory of reference 12, whereby:

$$C_{D_i} = \frac{KC_L^2 + K_1 \Delta C_{L_{c_{\mu}}}}{\pi A + 2 c_{\mu}}$$

$$\text{where } C_L^2 = (C_{L_{tot}} - C_{L_{0c_{\mu}=0}})^2$$

$$\Delta C_{L_{c_{\mu}}}^2 = (C_{L_{c_{\mu}}} - C_{L_{0c_{\mu}=0}})^2$$

C_{L_0} = Lift coefficient at minimum drag.

The factor, K is due to non-elliptic loading = $\frac{1}{e}$ and, $K_1 = K_A \cdot K_f$ is given in Figure 13 from reference 12.

K_A varies with wing aspect ratio and CCW flap cut-out* and K_f accounts for partial span blowing b^I/b_{tot} .

Application of this equation was made to both the A-6/CCW wind tunnel model, reference 10, and the T-2C/CCW model of reference 11, and compared with test results. The comparison of test data with estimates for a range of c_{μ} for $\alpha=0$ & 10° is shown in Figure 14 for the A-6/CCW and in Figure 15 for the T-2C/CCW. The factor K_1 , was taken directly from Figure 13 for both models. The value of K used for the T-2C was 1.2 consistent with an $e=.83$. For the A-6 however a $K=1.1$ was required to match the data, indicating an e of about .9 which is higher than would be estimated for that wing.

The comparisons of estimate with test data are however quite good indicating that this approach to induced drag prediction is reasonable.

* ratio of distance between inboard ends of flap to total span

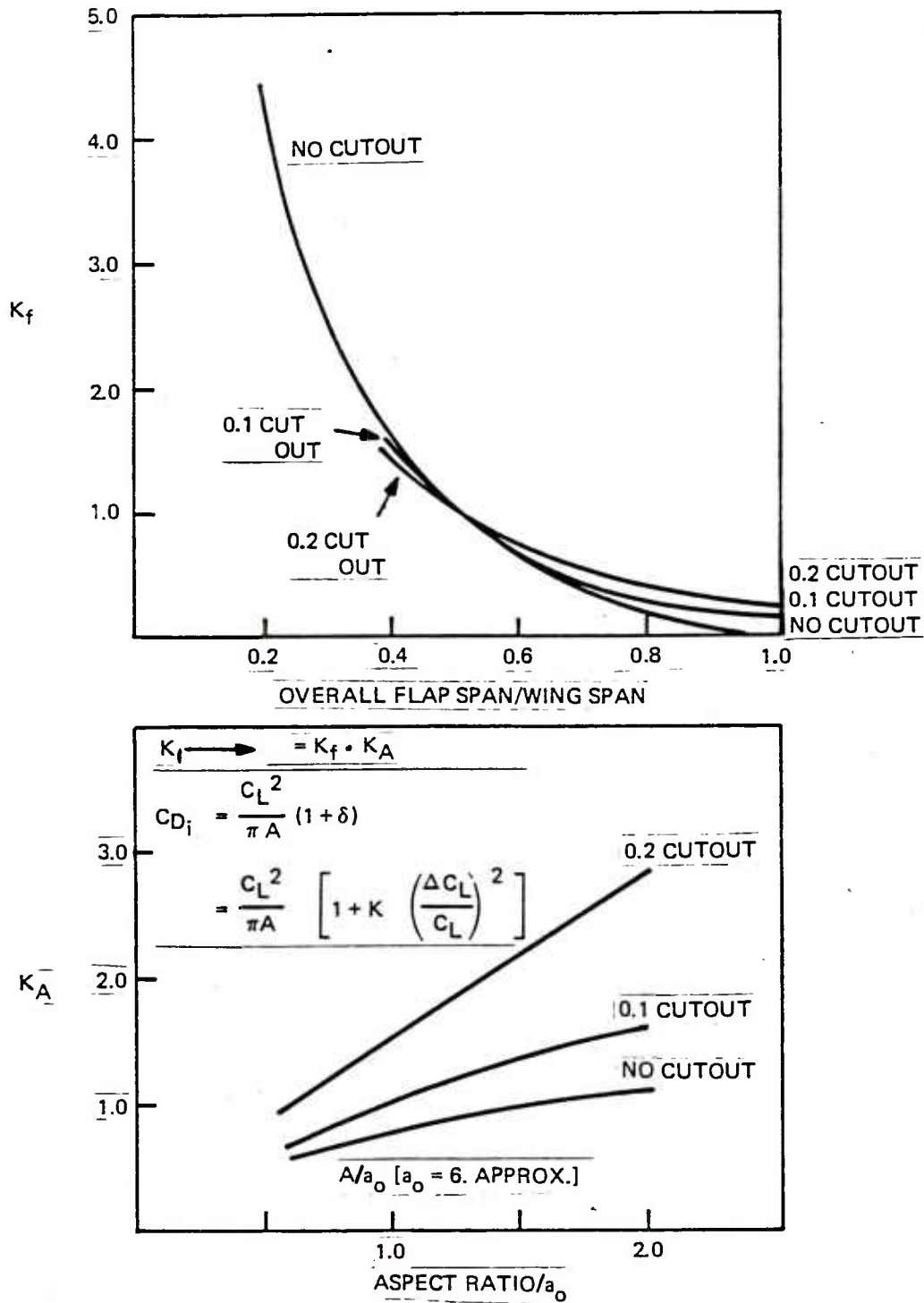

Figure 13. Effect of Aspect Ratio and Flap Span on Induced Drag Factor K

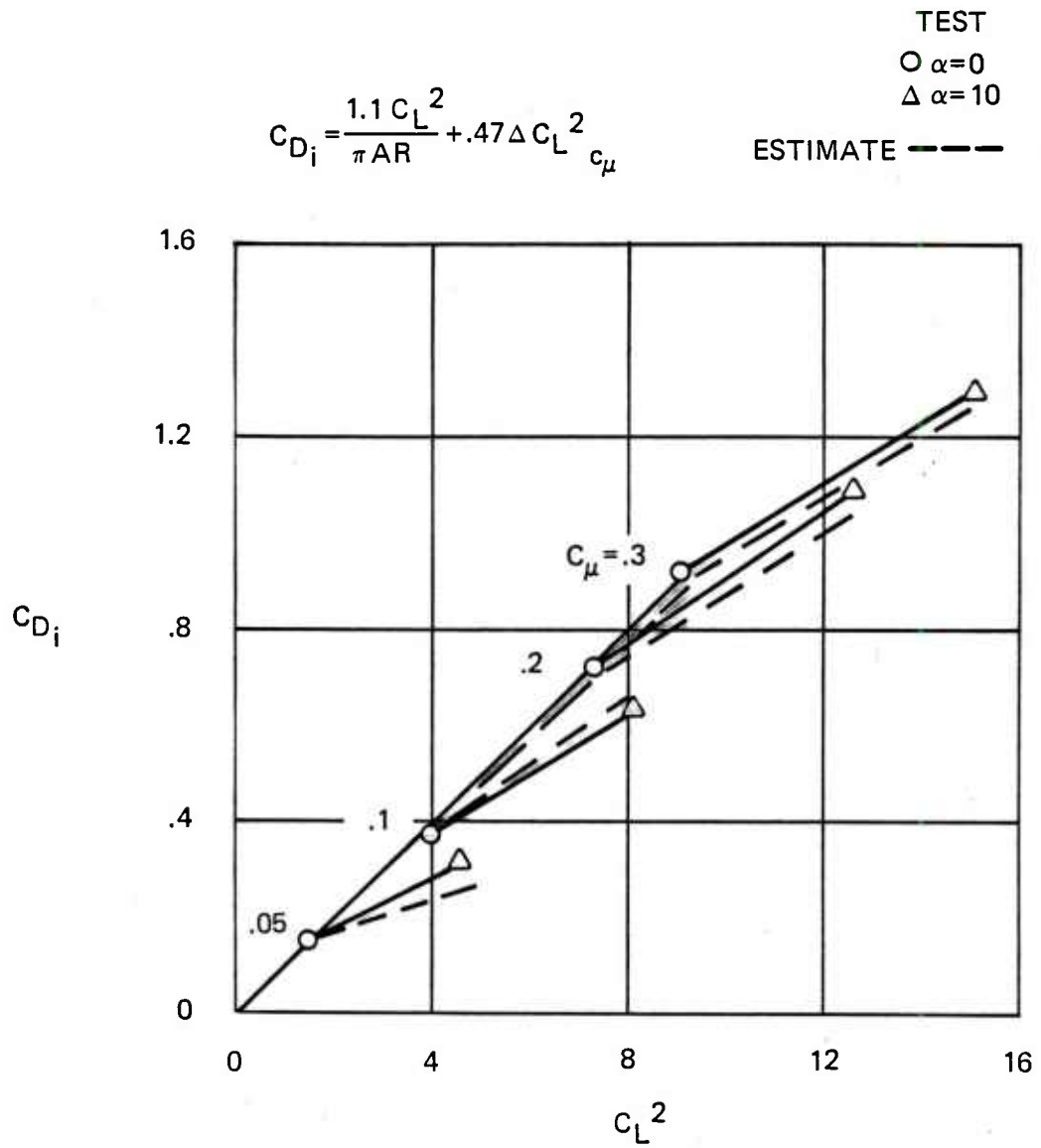

FIGURE 14. A-6/CCW Drag Due To Lift

$$C_{Di} = 1.2 \frac{C_L^2}{\pi AR} + \frac{K_A K_f}{\pi AR} \Delta C_L^2 C_\mu$$

$$K_A K_f = 1.02$$

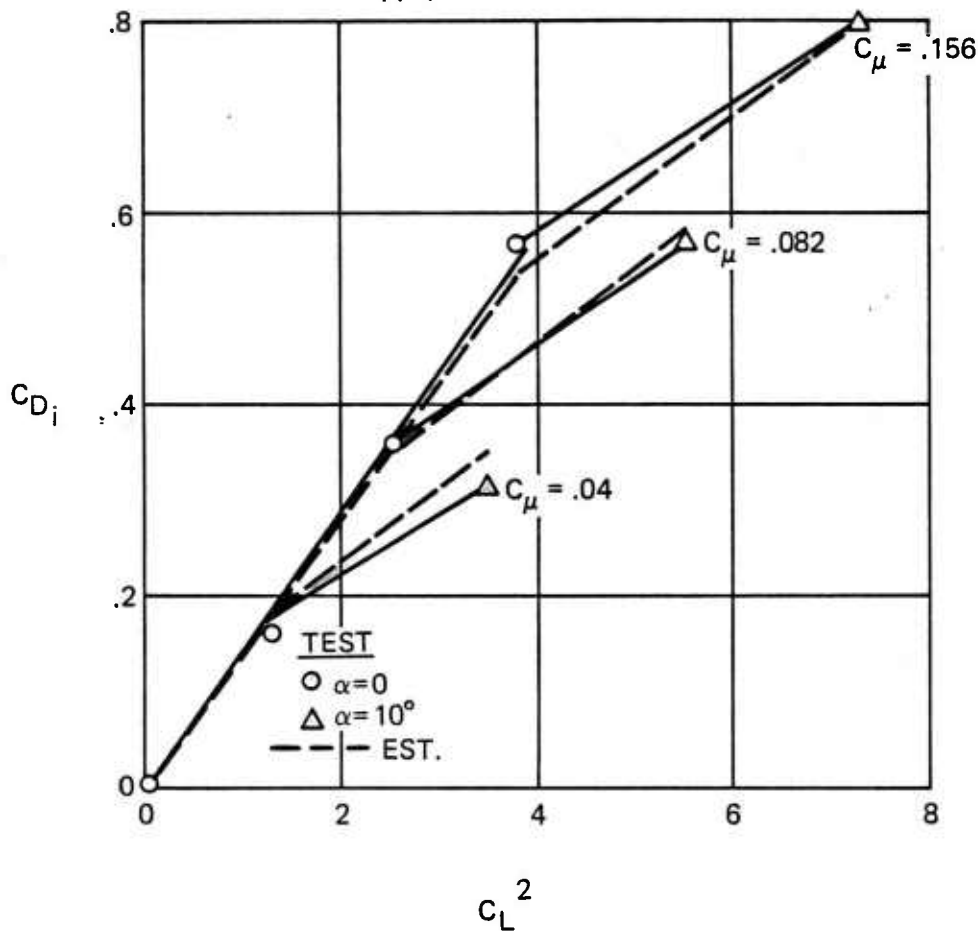

FIGURE 15. T-2C/CCW Drag Due To Lift

C O N C L U S I O N S

1. A semi-empirical engineering prediction technique has been developed for CCW based upon existing experimental data.
2. Both state-of-the-art airfoils and supercritical airfoils conform with the developed correlative parameters, when leading edge separation is not present. Leading edge devices are in general required for the state-of-the-art airfoils to delay leading edge separation and to extend the α range for higher C_{lmax} .
3. Lift due to CCW blowing acts at approximately the .55C wing location - generally imposing large nose down pitching moments. A separate test and analysis effort is required to determine tailplane downwash characteristics for distributed jet blowing systems in order to define tailplane design requirements and control characteristics.
4. Drag due to lift characteristics of the CCW generally conforms with the modified jet flap theory of references (9) and (12).

R E F E R E N C E S

1. Henderson, C., Clark J. and Walters, M., "V/STOL Aerodynamics and Stability and Control Manual", Report No. NADC-80017-60, January 1980.
2. Dunham, J., "A theory of Circulation Control By Slot-Blowing applied to a Circular Cylinder", J. Fluid Mech. Vol. 33, Part 3 pp 495-514, 1968.
3. Trentacoste N. and Sforza, P., "Further Experimental Results for Three Dimensional Free Jets" AIAA Journal, Vol. 5, No. 5, May 1967.
4. Englar, R. J., Lawrence, F. A., and Murphy, R. D., "Preliminary Study of Candidate Aircraft for a Circulation Control High Lift Wing Flight Demonstrator", DTNSRDC Rpt. ASED 330, December 1974.
5. Englar, R. J., "Two Dimensional Subsonic Wind Tunnel Tests of Two 15 percent Thick Circulation Control Airfoils", NSRDC AL211, August 1971.
6. Englar, R. J., "Low-speed Aerodynamic Characteristics of a Small Fixed Trailing Edge Circulation Control Wing Configuration Fitted to a Supercritical Airfoil", DTNSRDC/ASED-81-08, March 1981.
7. Englar, R. J., "Subsonic Two Dimensional Wind Tunnel Investigation of the High Lift capability of circulation Control Wing Sections", DTNSRDC/ASED-174, March 1975.
8. Maskall, E. C. and Spence, D. A., "A Theory of the Jet Flap in Three Dimensions", RAE, December 1958.
9. McCormick, B. W., "Aerodynamics of V/STOL Flight", Academic Press, 1967.
10. Englar, R. J., Trobaugh, L. A. and Hemmerly, R. A., "Development of the Circulation Control Wing to Provide STOL Potential for High Performance Aircraft", AIAA Paper 77-578, June 1977.

11. Englar, R. J., "Subsonic Wind Tunnel Investigation of the High Lift Capability of a Circulation Control Wing on a 1/5 Scale T-2C Aircraft Model", NSRDC AL-299, May 1973.

12. Young, A. D., "The Induced Drag of Flapped Elliptic Wings With Cut-out and With Flaps that Extend the Local Chord", Ministry of Supply, Memorandum 2544, February 1942.

D I S T R I B U T I O N L I S T (Continued)

	<u>No. of Copies</u>
Boeing Company, Seattle, WA 98101 (1 for E. Omar)	1
LTV Aerospace Corporation, Dallas, TX 75221 (1 for T. Beatty)	2
Rockwell International, Columbus, OH 43216	1
General Dynamics Corporation, Ft. Worth, TX 76108 (1 for W. Folley)	1
Nielson Engineering, Mountain View, CA 94043.	1
Lockheed-California Company, Burbank, CA 91503 (1 for Y. Chin)	1
Northrop Corporation, Hawthorne, CA 90250 (1 for P. T. Wooler)	1
Grumman Aerospace Corporation, Bethpage, Long Island, NY 11704	1
Royal Aeronautical Establishment, Bedford, England (1 for A. Woodfield)	1
Fairchild-Republic Corporation, Farmingdale, Long Island, NY. 11735	1
Calspan, Buffalo, NY 14221	1
McDonnell Douglas Corporation, St. Louis, MO 63166	1
V/STOL Consultant, Newport News, VA 23606	1
Georgia Institute of Technology, Atlanta, GA 30332 (1 for Dr. H. McMahon)	1
Penn State University, University Park, PA 16802 (1 for Prof. B. W. McCormick)	1
University of Tennessee, Space Institute, Tullahoma, TN 37388 (1 for W. Jacobs)	1

NADC-82186-60

D I S T R I B U T I O N L I S T

AIRTASK NO. A03V-320D/01B/7F41-400-000

	<u>No. of Copies</u>
COMNAVWPNCEN, China Lake, CA	1
CONAVAIRPROPCEN, Trenton, NJ.	1
DTNSRDC, Bethesda, MD (1 for Dr. H. Chaplin)	1
CNR, Arlington, VA (1 for Dr. R. Whitehead)	1
NAVPGSCOL, Monterey, CA (1 for Dr. M. Platzer)	1
NASA, Ames, Moffett Field, CA (1 for D. Hickey) (1 for W. Deckert)	2
NASA, Langley, Hampton, VA (1 for R. Margason)	1
NASA, Lewis, Cleveland, OH	1
AFFDL, WPAFB, OH	1
AFASD, WPAFB, OH	1
Pentagon, Washington, DC (1 for R. F. Siewert, OAD/ET, Room 3D1089)	1
CG, Army Aviation Systems Command, St. Louis, MO	1
CG, Army Research Office, Durham, NC	1
NAVAIR, (AIR-950D) (2 for retention) (1 for AIR-320D) (1 for AIR-5301)	4
NAVAIRDEVEN, Warminster, PA (1 for 605) (1 for 605DF) (2 for 60011) (1 for 6053) (6 for 6053DF) (3 for 811) (6 for 6053: Henderson)	20

DTIC 12

CONTINUED ON INSIDE OF COVER

8200139