

ADA 126708

Reason For	
NTIS GRA&I	<input checked="" type="checkbox"/>
DTIC TAB	<input type="checkbox"/>
Unannounced	<input type="checkbox"/>
Justification	
By _____	
Distribution/	
Availability Codes	
Dist	Avail and/or Special
A	21



DTIC
ELECTRICAL
APR 13 1983

S
D

Power Combiner with Gunn Diode Oscillators

JOSEPH J. POTOCZNIAK, HAROLD JACOBS, FELLOW, IEEE, CHARLES M. LO CASIO, AND
GABRIEL NOVICK, MEMBER, IEEE

DTIC FILE COPY

Abstract—Combiners were developed using two Gunn diodes in dielectric waveguide (image line) oscillator circuits. The optimum configuration consisted of each Gunn diode being imbedded in a separate dielectric cavity as a primary source of oscillation. The dielectric resonators were then radiatively coupled to a common dielectric resonator from which the combined power could be obtained. It was found that the combined power was greater than the sum of the power obtainable from separate isolated oscillators. The proposed combiner appears attractive from the point of view of simplicity of construction and low cost and should be applicable to the millimeter-wave region, where the difficulties of precision machined metal-walled cavities are very great.

I. INTRODUCTION

IN THE SEARCH for higher power semiconductor diode oscillator devices, the use of combiners has been suggested. Kurokawa [1] has published results with 12

Manuscript received November 12, 1981; revised December 30, 1981.
J.J. Potoczniak and H. Jacobs are with the Electronics Technology and Devices Laboratory, Fort Monmouth, NJ 07703.

C.M. LoCasio and G. Novick are with the Electronic Engineering Department, Monmouth College, West Long Branch, NJ 07764.

packaged IMPATT diodes giving 10.5-W CW output at 9.1 GHz. He coupled individual coaxial oscillators to a main cavity from which the energy was extracted. He further found that it was important to have minimal coupling between the oscillators and also small coupling coefficient from the oscillator to the main cavity. The coaxial structures (housing the resonators) were separated by $1/2$ wavelength and were individually tuned so that each resonator-diode combination would oscillate at the same frequency. Further work by Kurokawa [2] gave a detailed theory for the design of his combiner assembly.

Following these publications, due to the power limitations of IMPATT diodes, many investigations associated with millimeter waves have turned to investigating IMPATT diode combining techniques at 94 GHz and 140 GHz as the only means of obtaining adequate power [3] for radar applications using solid-state devices.

In this report, efforts were made to combine two Gunn diodes for approximately 10-GHz operation. Furthermore,

the investigations involved the use of dielectric waveguide cavities, rather than metal-walled cavities. The reasons for using dielectric cavities are: 1) It is assumed that in the future dielectric cavities will be less costly for microwave and millimeter-wave oscillators since mechanical tolerances are not as stringent; 2) there have been no investigations reported in the literature on combiners using the dielectric approach, even though individual diodes have worked well in cavity resonators [4]. The purpose here was to establish the feasibility of dielectric oscillator combiners and to determine the characteristics and required design structures for their operation.

II. EXPERIMENT

The physical arrangement of the oscillators used to perform the experiments is shown in Fig. 1. This oscillator gave the best results of the several configurations tried. The Gunn diodes were utilized with each one being separately biased. Each diode *D* was placed in a silicon resonator *F* in which a hole (3-mm diameter) had been previously drilled. The Gunn diode was anchored to a brass floor plate, and the silicon rectangular pieces were mechanically held in place by a teflon holder (not shown) attached to the roof *B* of the metal-walled structure.

Bias pins *E* were arranged so that mechanical contact could be made to the top of each Gunn diode as well as supplying dc electrical power. As previously described [4], when a Gunn diode is imbedded in high resistivity silicon *F*, the dielectric walls provide sufficient reflection from an air boundary to establish an oscillatory condition. Each resonator is an oscillator with some degree of tuning capability obtained by changing the bias voltage. The rectangular rod *G* served as the main resonator analogous to the Kurokawa large rectangular chamber. This rod was made of Al_2O_3 , with a dielectric constant of 9.6 compared with silicon of 11.8. It is to be noted that the main cavity, when made of Al_2O_3 , gave better results than when constructed of silicon. Fine tuning was carried out by the sliding short *C* which could be adjusted by the threaded screw located outside the metal wall *A*. The dimensions of Al_2O_3 dielectric resonator *G* were 3.5 mm high, by 7 mm wide, by 80 mm in length. The length was experimentally chosen to give optimum output. The silicon resonator pieces were 3.5 mm high, by 7 mm wide, by 18 mm in length. The wavelength at 10 GHz in silicon has been determined to be 1.5 cm [5]. Placing the entire dielectric assembly within a metal-walled cavity enhanced the output. It was found that the oscillator diodes would lose considerable power if they were not enclosed. It is noted that once the radiation was launched in a propagating mode in a uniform (undisturbed) dielectric line, little or no radiation loss was found. Therefore, it was important to cover the diodes (active devices), but once the wave was launched in *G*, it would propagate down the line without loss and with no additional requirement for metal covers. If an open waveguide were now placed over the far end of *G*, the radiation could be picked up, transmitted, and measured in a standard X-band metal waveguide setup (Fig. 2). In the arrangements shown in Figs. 1 and 2, the individual diodes were

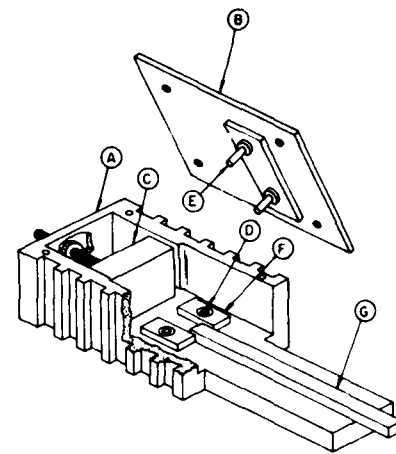

Fig. 1. Gunn diode configuration.

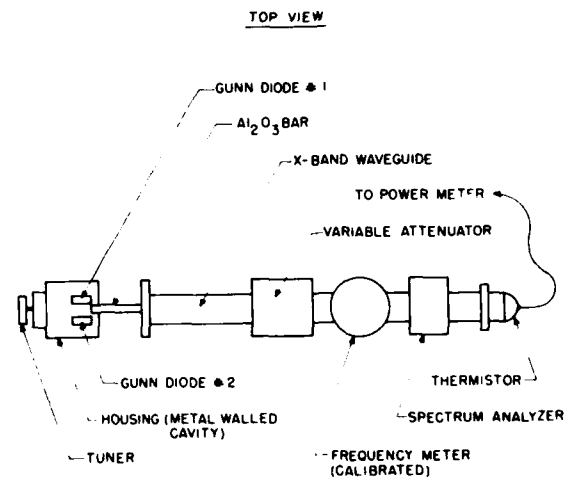

Fig. 2. Gunn diode test configuration with waveguide and meters.

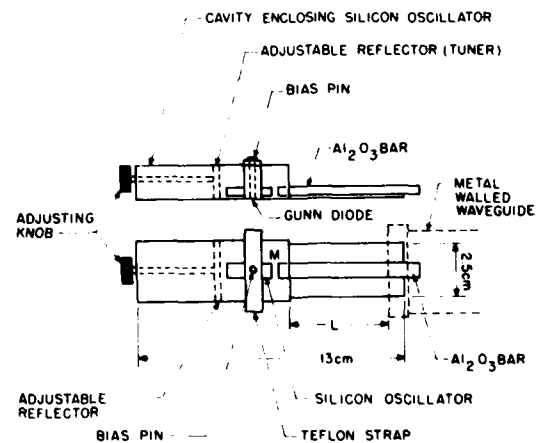

Fig. 3. Single Gunn diode, top and side view.

rated by the vendor at 78 mW (diode 1) and 84 mW (diode 2), at 9.0 V, when tested individually in a metal walled cavity at 10 GHz. In both cases, the rated current was 0.49 A. In order to verify the vendor's power ratings and to determine the individual diode capability in a dielectric

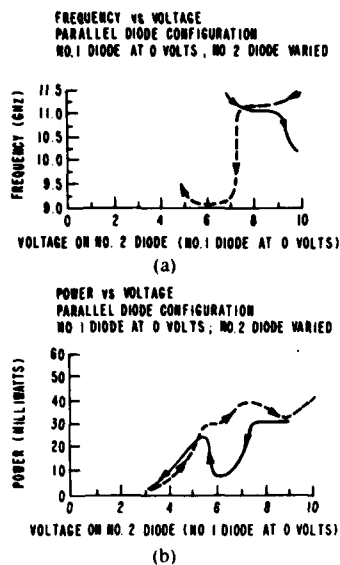

Fig. 4. Power and frequency versus voltage. Diode 1 at 0 V, diode 2 varied.

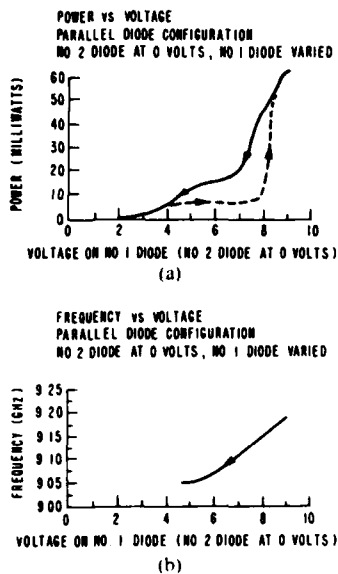

Fig. 5. Power and frequency versus voltage. Diode 2 at 0 V, diode 1 varied.

oscillator, a special cavity was constructed whereby the Gunn diode was inserted in a single rectangular structure. The diode was then tested to determine its maximum power output. The arrangement is shown in Fig. 3.

After making the adjustments in optimizing the position of the tuner, the distances L and M , the maximum power observed was 64 mW. This was obtained at 9.0 V, 0.49-A bias current, and the frequency was 10.525 GHz. The second diode demonstrated a maximum power output of 70 mW. These tests established that the Gunn diode could deliver power output to the dielectric rod in the same order of magnitude as to a metal-walled system. The next step was to construct two dielectric cavities in a metal box coupled to the single main resonator (Fig. 1) and to de-

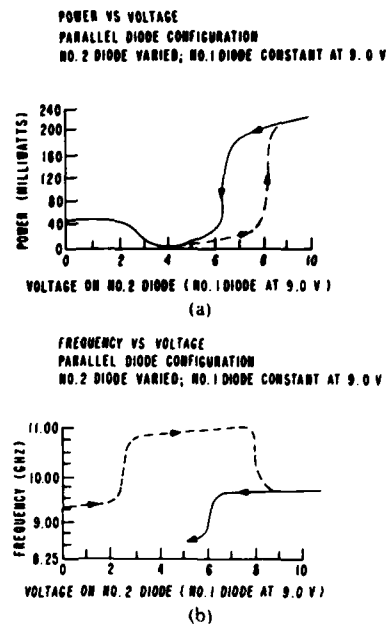

Fig. 6. Power and frequency versus voltage. Diode 2 varied, diode 1 constant at 9.0 V.

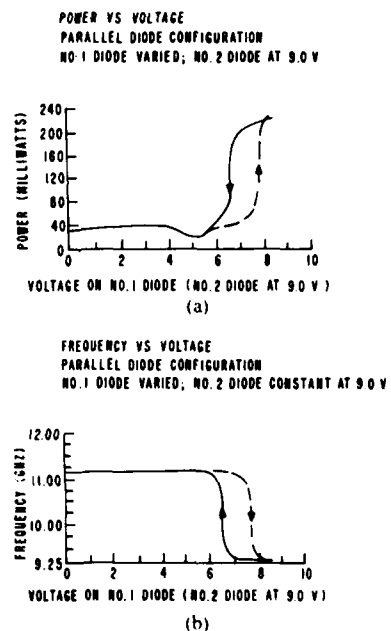

Fig. 7. Power and frequency versus voltage. Diode 1 varied, diode 2 constant at 9.0 V.

termine the maximum power obtainable from the combined oscillation of both Gunn diodes. When both diodes were operated simultaneously in the combiner, a maximum power output of 235 mW was obtained. This result indicates a power output of approximately four times the power output of a single diode. To verify this result, additional tests were run in the combiner assembly with one diode on and the other off, and vice versa. Figs. 4 through 7 show frequency and power versus voltage graphs.

Voltage was applied at an initial voltage, decreased to zero volts, and then increased back to the original voltage. The direction of the arrow on the graph shows whether the voltage was being increased or decreased. As seen in Fig. 4, at 9.0 V the power output has leveled at 30 to 40 mW and the frequency at 9.0 V is approximately 11.1 GHz for diode 2. As shown in Fig. 5, when the right diode (2) was at zero volts and the left (1) was set at 9.0 V, the power output was about 60 mW and the frequency was about 9.2 GHz. These values of frequency were checked by both the spectrum analyzer and the cavity type frequency meter. While operating both diodes in the combiner at 9.0 V, Figs. 6 and 7 indicate that 220 mW could be readily obtained. In Fig. 6, the right diode (2) is varied in voltage and a pulling effect is noted. But as the voltage on the diode 2 increases, the combiner system operates near 11 GHz and then locks to about 9.5 GHz. Similar effects appear in Fig. 7. Here, diode 1 is varied and with diode 2 fixed at 9.0 V, the characteristics of diode 2 appear.

The tests show that both diodes at 9.0 V locked into the same frequency. This frequency is closer to that of diode 1, which had the greater experimental power output in the combiner structure.

Close examination by means of a spectrum analyzer revealed no harmonics to be present in the Gunn diode combiner assembly used for our experiments and stability equal to or better than the single diode oscillator. During the course of these experiments, it was noted that the combiner stability appeared better than the individual diode oscillator stability in that there was less frequency fluctuation. The configuration presented in this paper has thus far presented itself as a means of achieving higher power via the implementation of combined Gunn diodes.

III. THEORETICAL CONCEPTS

We next propose a mechanism for the dielectric waveguide combiner experiments described above. Previous workers have described single diode oscillators in dielectric structures. Itoh [6] and Hsu have successfully imbedded Gunn diodes in dielectric lines. Also, Jacobs [7] and Novick have constructed oscillators by imbedded diodes in a dielectric cavity. Using a transmission line analysis, these investigators have developed an equivalent circuit for the dielectric oscillator consisting of a negative conductance device feeding into two parallel transmission lines. These transmission lines represent the equivalent circuit for lengths of dielectric waveguide. Each length is terminated by the load which represents the admittance of one side including radiation loss, and the other load can be either an open circuit or another admittance representing radiation loss and/or tuning susceptance. The reader is referred to these articles for further details. From the point of view of electromagnetic field theory, these dielectric oscillators are dielectric waveguides with the wave being reflected back from the ends and the diode acting as the electromagnetic source. In support of this concept, it was also found experimentally that the radiation beam emanated almost completely from both ends of the dielectric rectangular waveguide with an azimuthal angle of about 50°.

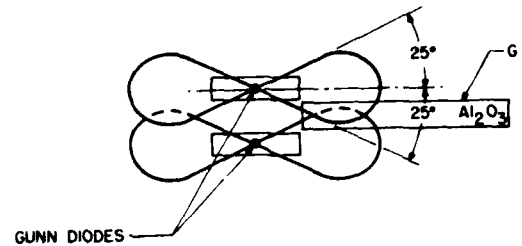

Fig. 8. Radiation lobes with coupling to dielectric cavity.

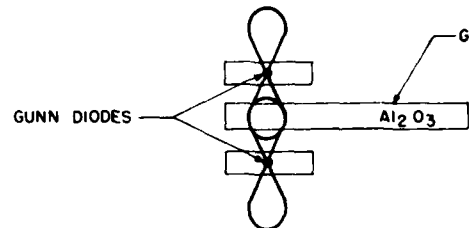

Fig. 9. Illustration of lobes with diode-to-diode coupling.

In the concepts leading to the experiments reported here, it was assumed that a combiner could be developed using the principle that two rectangular dielectric cavities would be made to radiate and couple into a common dielectric cavity which could in turn serve as a central resonator. Therefore, in these experiments, cavities were constructed of the same materials and the same dimensions as reported by Jacobs and Novick with the expectation that coupling could be achieved by the arrangement shown in Fig. 8.

The oscillator cavities *F* (of Figs. 1 and 8) are so directed that the radiation from each oscillator is emitted in the longitudinal direction of the Al_2O_3 resonator *G*. It is known that the main lobe of radiation exists from the narrow end where the diode cavities are in the position shown in Fig. 8, with respect to the Al_2O_3 resonator. The diode-to-diode coupling may be significant, but not as great as if both diodes were in the same dielectric cavity. The position of the Al_2O_3 central cavity can be adjusted to give optimum matching for the maximum output coupling.

It was reasoned that if *G* is moved back, as shown in Fig. 9, the diode-to-diode coupling can become too great due to the change in the direction of radiation.

Experiments of this kind were tried and it was found that optimum results were obtained with the configuration shown in Fig. 8. When configurations in Fig. 9 were tried, no oscillations were obtained. It is noted that in the arrangement shown in Fig. 8, the output power was enhanced when a large metal enclosure was used. The enclosure was used to prevent excessive loss due to radiation, and, furthermore, the slide screw tuner in back of the metal enclosure enhanced the output power. It is recognized that the metal enclosure will modify the radiation patterns, but it is reasonable to expect that the main source of the radiation is coming out of the ends of the dielectric waveguide oscillators and is then coupling the Al_2O_3 central resonator which in turn is the radiating source of the assembly.

In the case of the dielectric waveguide, coupling (and

pulling of frequency) was observed between the diode oscillators, i.e., 9.0 GHz to about 9.5 GHz and 11.0 GHz to about 9.5 GHz. The mutual pulling results in the oscillations which require no manual tuning for each separate diode.

Another experimental result of these investigations is that for two oscillators combined, the power output is greater than the sum of each individual oscillator. It is possible that the combiner serves to better match the two diodes to the output impedance more efficiently than can be done with a single diode. It would be interesting to conjecture whether or not more than two oscillators could be combined.

IV. CONCLUSIONS

Experimental procedures have been described which have demonstrated that two Gunn diodes can be combined using a combination of two dielectric waveguide oscillators, a central cavity also consisting of dielectric transmission line, and metal-walled enclosures to suppress radiation and enhance tuning. Power outputs of about four times that obtainable from a single diode were demonstrated. It was found that the two diodes need not be tuned individually, but will lock to the same frequency with minimal mechanical tuning.

REFERENCES

- [1] K. Kurokawa, "An X-band 10 W multiple IMPATT oscillator," in *Proc. IEEE*, vol. 50, pp. 102-103, Jan. 1971.
- [2] K. Kurokawa, "The single cavity multiple device oscillator," *IEEE Trans. Microwave Theory Tech.*, vol. MMT-19, pp. 793-801, Oct. 1971.
- [3] "Development of millimeter-wave combiners," Hughes Tech. Rep., Hughes Aircraft Co., Contract DAAK20-79C-0259.
- [4] H. Jacobs, G. Novick, C. LoCascio, and M. Chrepta, "Measurements of guide wavelength in rectangular dielectric waveguide," *IEEE Trans. Microwave Theory Tech.*, vol. MTT-24, no. 11, pp. 815-820 Nov. 1976.
- [5] H. Jacobs, G. Novick, C. LoCascio, and R. Walters, "Probe measurements of guide wavelength in rectangular silicon dielectric waveguide," in *Proc. 1977 Int. Microwave Symp.* (San Diego, CA) June 21-23 1977.
- [6] T. Itoh and Fwu-Jih Hsu, "Distributed bragg reflector Gunn oscillator for dielectric millimeter-wave integrated circuits," *IEEE Trans. Microwave Theory Tech.*, vol. MTT-27, pp. 514-518 May, 1979.
- [7] H. Jacobs, G. Novick, C. LoCascio, and M. Chrepta, "Measurements of guide wavelength in rectangular dielectric waveguide," *IEEE Trans. Microwave Theory Tech.*, vol. MTT-24, no. 11, pp. 815-820 Nov. 1976.



New Jersey

Joseph J. Potoczniak is employed by the U.S. Army Electronics Research and Development Command, Electronics Technology and Devices Laboratory, Microelectronics Division, Fort Monmouth, New Jersey. He holds a Bachelor of Science in industrial engineering from New Jersey Institute of Technology, a Master of Science in management science from Stevens Institute of Technology, a Master of Science in electronics engineering from Monmouth College, and a Professional Engineers License from the State of



Harold Jacobs (SM'59-F'68) was born in Port Chester, NY, on November 21, 1917. He received the B.A. degree from John Hopkins University, Baltimore, MD, and the M.S. and Ph.D. degrees from New York University, New York, NY.

He joined the U.S. Army Signal Corps Laboratory, Fort Monmouth, NJ, in 1949, with previous experience at RCA Mgn. Company, Lancaster, PA, and Sylvania Electric Products, Kew Gardens, NY. He has worked in the areas of electron tubes, solid-state devices, lasers, and microwave and millimeter-wave devices. He has served as Professor of Electronic Engineering at Monmouth College, West Long Branch, NJ.

Dr. Jacobs received the IEEE Fellow Award in 1967 for his semiconductor devices contributions and the Army's Decoration for Exceptional Civilian Service in 1969 for millimeter-wave imaging investigations. In 1973 he was the recipient of the IEEE's Harry Diamond Award for identification of bulk semiconductor effects at millimeter waves with application to imaging and surveillance.



Charles M. LoCascio was born in Messina, Italy, in 1907.

He joined the Thermionics Branch of the U.S. Army Electronics Command at Fort Monmouth, NJ, in 1940. He worked with the late Dr. Harold Zahl in areas of microwaves, radar, lasers, and associated circuitry. He was Supervisor of the techniques section when he retired in 1971. Since that time, he has been associated with the Electronic Engineering Department of Monmouth College, West Long Branch, NJ.



Gabriel Novick (S'47-M'49) was born in New York City, NY, on January 19, 1925. He received the B.E.E. degree from the City College of New York, NY, in 1947, the M.E.E. degree from the Polytechnic Institute of Brooklyn, Brooklyn, NY, and the Ph.D. degree from Stanford University, Stanford, CA, in 1961.

During World War II he served briefly in the armed forces. From 1950 to 1955 he worked at the Signal Corps Engineering Laboratory (SCEL), Fort Monmouth, NJ. His primary work was on various cross-field microwave tubes such as magnetrons, carcinotrons (cross-field BWO), and cross-field amplifier tubes. Previously, he had obtained some microwave and antenna experience at the Polytechnic Research and Development Co., Brooklyn, NY, and the Channel Master Corp., Ellenville, NY. In 1955 he joined the General Electric Microwave Laboratory, Palo Alto, CA, where he worked on various types of microwave tubes, such as an external-circuit cross-field tube, a megawatt klystron, and a low-noise TWT. Under the G.E. Honors Co-Operative Program, he attended Stanford University. From 1965 to 1973 he was a member of the Electronic Warfare Laboratory, part of the U.S. Army Electronics Command, Fort Monmouth, NJ. He worked on various electronic and electrooptical countermeasures systems such as the MULTIEW system, the Expandables, and the Protection of Armored Vehicles. At the present time, he is a faculty member of the Electronic Engineering Department of Monmouth College, West Long Branch, NJ, where in addition to teaching, he works in the laboratory on various projects such as ruby lasers, neodymium glass lasers, CO₂ lasers, thermistor detectors for the infrared spectrum, microwave components, and various microwave subsystems.

Dr. Novick is a Licensed Professional Engineer in the state of California, and a member of AAAS, AAUP, AOC, ASHS, DAV, and Sigma Xi.