

12

DOT/FAA/CT-82/33-N

Computer Simulation of an Aircraft Seat and Occupant in a Crash Environment

Volume II - Program SOM-LA User Manual

David H. Laananen
Joseph W. Coltman
Akif O. Bolukbasi

March 1983

Final Report

This document is available to the U.S. public
through the National Technical Information
Service, Springfield, Virginia 22161.



US Department of Transportation
Federal Aviation Administration
Technical Center
Atlantic City Airport, N.J. 08405

DTIC
ELECTRONIC
S APR 25 1983
A

DTIC FILE COPY

1. Report No. DOT/FAA/CT-82/33-III		2. Government Accession No. AD-A127 286		3. Recipient's Catalog No.	
4. Title and Subtitle COMPUTER SIMULATION OF AN AIRCRAFT SEAT AND OCCUPANT IN A CRASH ENVIRONMENT, VOLUME II - PROGRAM SOM-LA USER MANUAL				5. Report Date March 1983	
				6. Performing Organization Code	
7. Author(s) D. H. Laananen, J. W. Coltman, A. O. Bolukbasi				8. Performing Organization Report No. TR 81415	
9. Performing Organization Name and Address Simula Inc. 2223 S. 48th Street Tempe, Arizona 85282				10. Work Unit No. (NAIS)	
				11. Contract or Grant No. DTFA03-80-C-00098	
10. Sponsoring Agency Name and Address Federal Aviation Administration Technical Center Atlantic City Airport, New Jersey 08405				13. Type of Report and Period Covered Final September 1980- September 1982	
				14. Sponsoring Agency Code ACT-330	
15. Supplementary Notes					
16. Abstract A mathematical model of an aircraft seat, occupant, and restraint system has been developed for use in analysis of light aircraft crashworthiness. Because of the significant role played by the seat in overall system crashworthiness, a finite element model of the seat structure is included. The seat model can accommodate large plastic deformations and includes the capability for simulation of local buckling of bending members. Because the program has been written for use primarily by engineers concerned with the design and analysis of seat and restraint systems, an effort has been made to minimize the input data required to describe the occupant. This volume of the final report presents instructions for preparing input data and operating the program, supported by detailed examples. Sample material properties and modeling parameters are also included.					
17. Key Words Aircraft Computer Simulation Crashworthiness Restraint Systems Seats			18. Distribution Statement Document is available to the U.S. public through the National Technical Information Service, Springfield, Virginia 22161		
19. Security Classif. (of this report) Unclassified		20. Security Classif. (of this page) Unclassified		21. No. of Pages 232	22. Price

FOREWORD

This report was prepared by Simula Inc. under Contract No. DTFA03-80-C-00098 with the Federal Aviation Administration (FAA) Technical Center, where L. M. Neri acted as Technical Monitor. Under the same contract, final modifications were made to both seat and occupant models, and validation was completed. The project had been originally initiated under a contract with the FAA Systems Research and Development Service and continued with the support of the Civil Aeromedical Institute.

The Simula Inc. Program Manager has been Dr. D. H. Laananen, and final modifications to the computer program have been developed by A. O. Bolukbasi and J. W. Coltman. Data for model validation have been provided by the Protection and Survival Laboratory, FAA Civil Aeromedical Institute, where a comprehensive test program was conducted under the leadership of R. F. Chandler, who has also provided valuable guidance throughout this project. J. Gillespie of the Flight Standards National Field Office, Oklahoma City, has also been of great assistance during program development and validation.



A

TABLE OF CONTENTS

	<u>Page</u>
1.0 INTRODUCTION	1
2.0 PROGRAM INPUT DATA	2
2.1 SIMULATION AND OUTPUT CONTROL INFORMATION	2
2.2 SECONDARY IMPACT OPTION	6
2.3 CUSHION PROPERTIES	6
2.4 RESTRAINT SYSTEM DESCRIPTION	6
2.5 CRASH CONDITIONS	7
2.6 OCCUPANT DESCRIPTION	7
2.7 SEAT DESIGN INFORMATION	7
3.0 PROGRAM OUTPUT DATA	10
3.1 PRINTED OUTPUT	10
3.2 OCCUPANT POSITION PLOTS	10
3.3 SEAT STRUCTURE PLOTS	10
3.4 ADDITIONAL DATA FOR PLOTTING	12
4.0 INSTRUCTIONS FOR INPUT DATA PREPARATION	16
5.0 SAMPLE SIMULATION CASES	18
5.1 CASE NO. 1: DYNAMIC TEST OF STRUCTURALLY SIMPLE SEAT	18
5.2 PRODUCTION GENERAL AVIATION SEAT	28
5.3 ENERGY-ABSORBING HELICOPTER SEAT	36
5.4 EXAMPLE OF COCKPIT GEOMETRY	38
6.0 REFERENCES	46
APPENDIX A - PROGRAM SOM-LA INPUT DATA REQUIREMENTS	A-1
APPENDIX B - EXAMPLES OF OCCUPANT CHARACTERISTICS AND MATERIAL PROPERTIES	B-1
APPENDIX C - OUTPUT OF PROGRAM SOM-LA FOR EXAMPLE CASE NO. 1	C-1

TABLE OF CONTENTS (CONTD)

	<u>Page</u>
APPENDIX D - PROGRAM STRUCTURE	D-1
APPENDIX E - OCCUPANT PLOTTING PROGRAM	E-1
APPENDIX F - SEAT PLOTTING PROGRAM	F-1

LIST OF ILLUSTRATIONS

<u>Figure</u>		<u>Page</u>
1	Twelve-segment (three-dimensional) occupant model	4
2	Eleven-segment (two-dimensional) occupant model	5
3	Occupant plot at $T = 0$ sec for case No. 1	11
4	Definition of plot viewing angle	12
5	Seat plot at $T = 0$ sec for case No. 1	13
6	Angular coordinates for viewing position for seat plots	14
7	Data format for external file 26	15
8	CAMI Series 2 test seat	19
9	CAMI Series 2, lower-deceleration, forward-facing test, pretest	20
10	CAMI Series 2, lower-deceleration, forward-facing test, posttest	21
11	Test configuration, CAMI Series 2, lower-deceleration, forward-facing tests	22
12	Sled deceleration, CAMI Series 2, lower-deceleration, forward-facing test	23
13	Finite element seat model	25
14	Exponential approximation to force-deflection characteristics for dummy and 1-in.-thick cushion	26
15	Approximation to sled acceleration	27
16	Element cross-section models used for seat structure beam elements	29
17	Listing of input data, case no. 1	30
18	Occupant plot at $T = 0.240$ sec for case no. 1	33
19	Seat plot at $T = 0.240$ sec for case no. 1	34

LIST OF ILLUSTRATIONS (CONTD)

<u>Figure</u>		<u>Page</u>
20	Production general aviation seat (with some node numbers indicated)	35
21	Finite element model of production seat	37
22	Beam element cross section	38
23	Input data listing, case no. 2	39
24	Configuration for dynamic test of energy-absorbing helicopter seat	42
25	Listing of input data	43
26	Energy absorber load-stroke characteristics	44
27	Example of cockpit coordinates (in.)	45
28	Additional data required to define cockpit geometry illustrated in figure 27 (lines 38A-38K)	45

1.0 INTRODUCTION

Program SOM-LA (Seat/Occupant Model - Light Aircraft) combines a lumped parameter model of an aircraft occupant with a finite element model of the seat structure. Its intent is to aid in the evaluation of the performance of aircraft seat and restraint systems in crash environments. Because the program has been written for use primarily by engineers concerned with the design and analysis of seats and restraint systems, an effort has been made to minimize the input required to describe the occupant. Characteristics of two standard occupants, one dummy and one human, are included within the program, and an option is provided to simulate other occupants by providing additional input data. The structural model can include both beam and plate elements and has a maximum capacity of approximately 450 degrees of freedom, as determined by array dimensions within the program. The beam elements can accommodate large plastic deformations and include the capability for cross-section reduction due to local instabilities. As an option to reduce both modeling complexity and execution costs for cases where only the restraint system or cockpit configuration is of concern, or for cases where the details of the seat design may not yet be known, a rigid seat model, in which seat pan and back planes defined by input are maintained in fixed positions in the aircraft, is available.

The following sections of this report present instructions necessary for the use of Program SOM-LA and information to enable the user to operate the program most efficiently.

Chapters 2 and 3 describe program input and output, respectively, including options available to the user. Chapter 4 outlines an efficient procedure for development of a mathematical model. Chapter 5 then provides detailed descriptions of sample input cases. Appendix A defines all input variables, line by line. Appendix B provides examples of material properties and occupant characteristics required as input data. Appendix C displays the complete set of output data for the input listed in chapter 5 and appendix A. Appendix D describes program organization and the functions of all subroutines. Appendices E and F are listings of the occupant and seat plotting programs, respectively.

2.0 PROGRAM INPUT DATA

Input data are read by Program SOM-LA in the following seven blocks:

1. Simulation and output control information.
2. Cockpit description (optional).
3. Cushion properties.
4. Restraint system description.
5. Crash conditions.
6. Occupant description.
7. Seat design information.

All input data, except those pertaining to the seat (block 7), are read by subroutine INPT; the seat data are read by subroutines SEATIN and READIN.

The coordinate system that is fixed to the aircraft at the floor has the following positive directions:

X - Forward
Y - Left
Z - Upward

The basic input data deck consists of a minimum of 41 lines of data for execution of Program SOM-LA. These are described in detail in Appendix A. The basic case makes use of a rigid seat model, specified by NSEAT = 0 on line 1. Modeling an actual seat with the finite element analysis would change lines 40 and 41, and require a number of additional lines. Requesting the storage of plot data on external files, unit 14 for the occupant and unit 20 for the seat, by setting NO PLOT > 0 or NSPLOT > 0 on line 2, requires additional lines following line 2. The prediction of contact between the occupant and aircraft interior, designated by IOUT(4) = 1 on line 2, would require a description of the cockpit configuration on 11 lines inserted after line 3. Modeling a nonstandard occupant requires an additional 12 data lines after line 37.

The following sections of this chapter present descriptions of each of the seven input data blocks, including more detailed definitions of the above options. Line-by-line descriptions of input data are presented in Appendix A.

2.1 SIMULATION AND OUTPUT CONTROL INFORMATION

2.1.1 Systems of Units. The NUNIT parameter on line 1 permits the user to specify either the SI or English system of units for

both input and output data. English units are presented throughout the input instructions in this report and are used in the sample input cases. In the SI system of units, all lengths are specified in meters, masses in kilograms, and forces or weights in newtons.

2.1.2 Seat Options. The NSEAT parameter on line 1 allows the user to select either a rigid seat model or a finite element seat model. The rigid seat model consists of two planes that represent the seat pan and seat back. The positions of these planes are specified by the X and Z coordinates of their intersection (a lateral line) and two angles which specify their positions relative to horizontal and vertical planes, respectively. The length of the seat pan and the height of the seat back are used to determine the limits of the surfaces within which the seat pan and back can apply forces to the occupant. Cushions, of input-specified thicknesses, are included on top of the seat pan and seat back surfaces.

2.1.3 Occupant Degrees of Freedom. The NDIM parameter on line 1 permits selection of either two- (NDIM = 2) or three-dimensional (NDIM = 3) occupant response. The three-dimensional occupant model consists of 12 rigid segments, illustrated in figure 1, with rotational springs and dampers at the joints. Each of the torso joints possesses three rotational degrees of freedom, or, in other words, is a ball-and-socket type joint. Because of the hinge-type motion at elbow and knee joints, the position of a forearm or lower leg relative to an upper arm or thigh, respectively, is described by one additional angular coordinate. In total, this occupant model possesses 29 degrees of freedom.

The two-dimensional occupant model specified by NDIM = 2 on line 1, consists of 11 segments, as shown in figure 2. Beam elements in the torso and neck are capable of flexural and axial deformation. Although restricted to two-dimensional response, this occupant option does permit more direct evaluation of accident severity by output of forces and moments in the spine and neck. Restraint system forces on the ellipsoidal contact surfaces are computed three-dimensionally, but only the X- and Z-components are used. Therefore, the two-dimensional model should be reserved for cases in which both the impact conditions and the restraint system are symmetrical.

2.1.4 Output Control Data. Ten blocks of program output can be selected on line 2. The data include time histories of the following variables, which are stored during solution at predetermined print intervals:

1. Occupant segment positions (X, Y, Z, pitch and roll).*
2. Occupant segment velocities (X, Y, and Z).

*Upper case X, Y, Z refer to inertial or aircraft-fixed coordinate system; lower case x, y, z refer to segment-fixed coordinates.

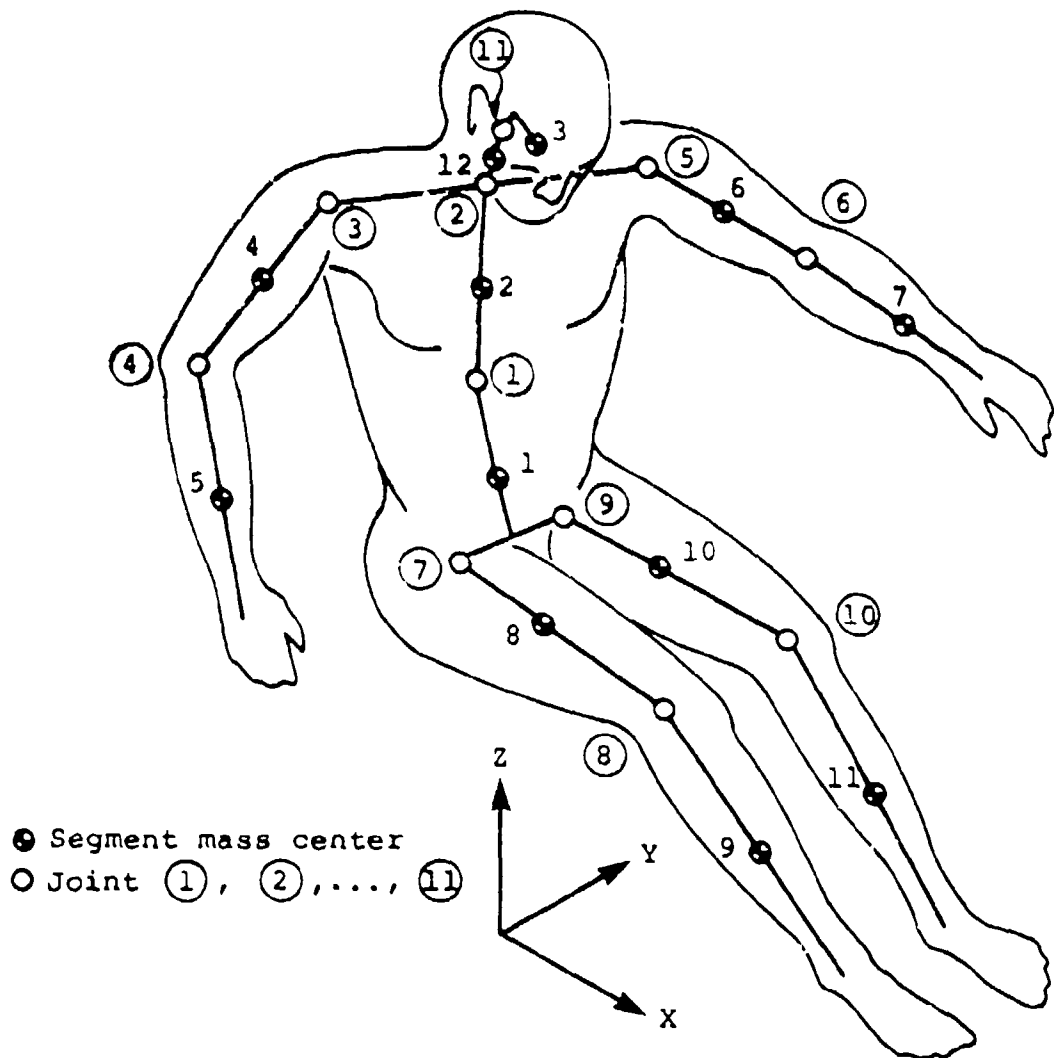
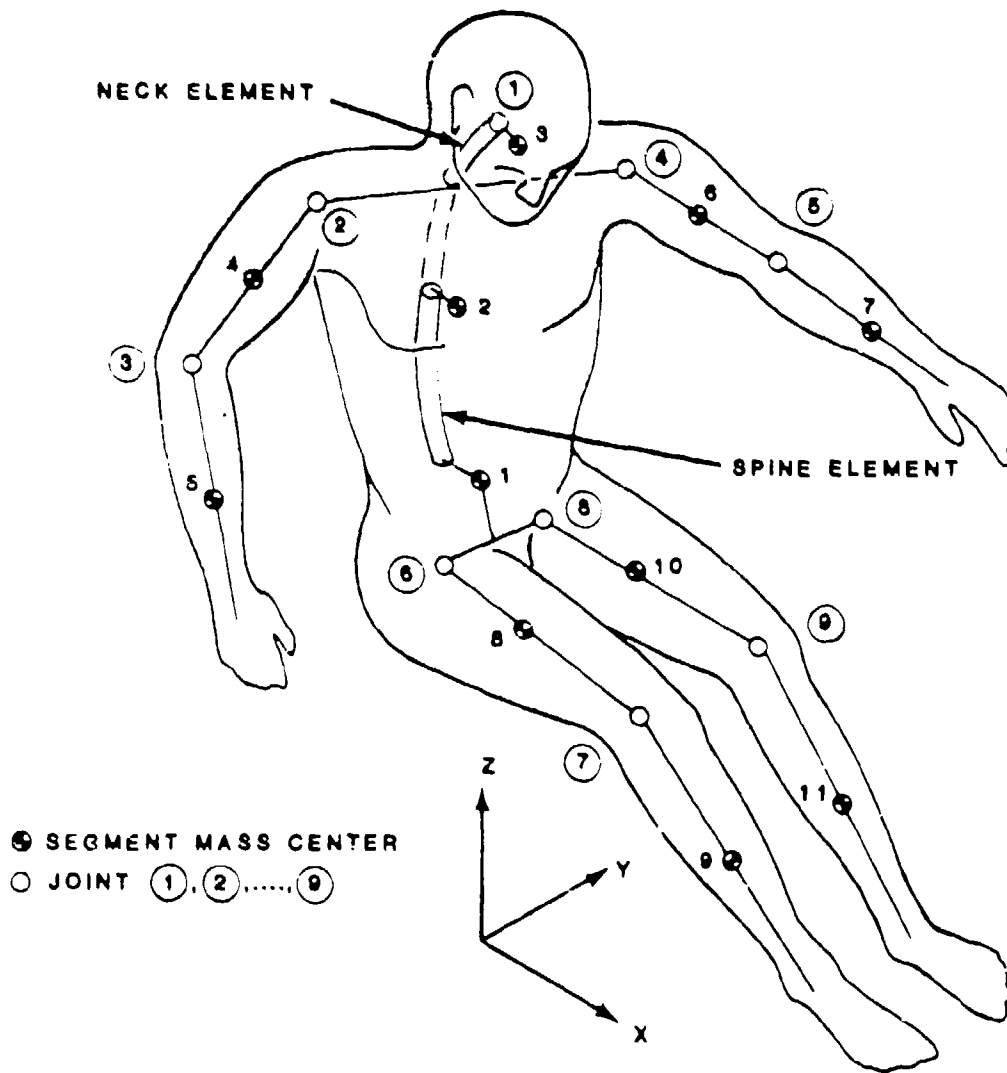

Figure 1. Twelve-segment (three-dimensional) occupant model.

- 3. Occupant segment accelerations (x, y, z , and resultants).*
- 4. Restraint system loads.
- 5. Cushion loads.
- 6. Aircraft displacement, velocity, and acceleration.
- 7. Injury criteria, including spinal forces and moments.
- 8. Details of contact between the occupant and the aircraft interior.

*Upper case X, Y, Z refer to inertial or aircraft-fixed coordinate system; lower case x, y, z refer to segment-fixed coordinates.



61 01001 03

Figure 2. Eleven-segment (two-dimensional) occupant model.

- 9. Seat structure nodal forces.
- 10. Seat structure element stresses.

Printer plots are provided for occupant segment accelerations, restraint system loads, and cushion loads. The option of two different filters is also provided for the occupant segment accelerations and cushion loads.

If plots are requested for the occupant and/or seat on line 2, then additional lines must be included to specify plot times (up to eight) and viewing angles. As explained in the line-by-line

input data descriptions, if plots are requested, the job control language must define external files 14 and 20 to be saved.

Program output data are described further in Chapter 3.

2.1.5 Solution Control Data. The occupant model utilizes an Adams-Moulton predictor-corrector solution procedure with a variable time step. Data on line 3 control the step size and error bounds for the solution. The finite element seat analysis uses a Newmark- β integration algorithm, whose time step is determined by the occupant solution.

At every solution step, the system central processor time is checked and compared with the TMAX parameter on line 3. Allowing time for output, the solution will be terminated once system time reaches TMAX, whether or not the final solution time, TF, has been reached. Therefore, the permitted execution time in the job control language should be at least TMAX seconds, in order to ensure that the solution is terminated in time to permit printing of the output already computed and stored.

2.2 SECONDARY IMPACT OPTION

If secondary impact information is desired, it can be specified by input of IOUT(4) = 1 on line 2. Additional lines must then be provided after line 3 to supply the coordinates of points that define cockpit geometry. An example of cockpit geometry is presented in section 5.4.

2.3 CUSHION PROPERTIES

Seat cushion forces applied to the occupant model are calculated from cushion deflections based on an exponential relationship:

$$F = C(e^{B\delta} - 1) \quad (1)$$

Lines 4 and 5, and 6A if a headrest is included on the seat, require input of the C and B coefficients for this equation, along with damping coefficients and thicknesses. The force-deflection relationship for the seat cushion also includes compliance of the occupant buttocks. Therefore, the relationship for an occupant sitting directly on a hard seat pan would be the force-deflection curve for the occupant buttocks. Several sample force-deflection curves with their appropriate coefficients are provided in Appendix B.

2.4 RESTRAINT SYSTEM DESCRIPTION

Several restraint system configurations are available in SOM-LA: lap belt only, lap with diagonal shoulder belt over either shoulder, and double shoulder belt with or without a lap belt tiedown strap. As specified on line 6, both the lap belt and shoulder harness can be attached to either the airframe or the seat.

The force-deflection characteristics of the restraint system webbing are provided by input of tables of forces and strains. Properties of representative webbing samples are included in Appendix B.

For a seat in which an inertia reel is mounted on the seat back and a length of inertia reel strap is passed along the seat back to a slot above the occupant shoulders, the XTRAL parameter on line 10 defines the length of the shoulder strap behind the seat back.

2.5 CRASH CONDITIONS

Six components of the acceleration of the aircraft coordinate system are provided on lines 11 through 34: X, Y, Z, yaw, pitch, and roll. All of these lines must be included, even if blank. For each acceleration component, two lines are included to allow up to 16 points on an acceleration-time history, and the subsequent two lines provide the corresponding points in time. Acceleration components are directed in the aircraft-fixed coordinate system.

2.6 OCCUPANT DESCRIPTION

The IMAN parameter on line 37 identifies the type of occupant being simulated. Data for the standard occupants, a 50th-percentile U.S. male and a 50th-percentile (Part 572) anthropomorphic dummy, are included within the program. For nonstandard occupants, additional data may be provided following line 38 to define segment lengths, center of mass locations, weights, moments of inertia, contact surface radii, properties for the spine and neck, and compliances for the chest and abdomen under restraint system loading. Examples of these data are included in Appendix B.

The angular orientations of the torso, head, and arm segments are provided as input, along with the X-coordinate of the heels. Static equilibrium is then used to seat the occupant in the cushions.

2.7 SEAT DESIGN INFORMATION

2.7.1 Rigid Seat Option. For cases where the details of seat response are not important or not worth the greater execution costs that would be incurred by the use of the finite element structural model, a rigid seat option is provided. Plane surfaces representing the seat pan and seat back support the cushions and remain fixed in the aircraft coordinate system, except where the energy-absorbing option is used.

2.7.2 Simplified Energy-Absorbing Seat Option. If the SEATM parameter on line 40 is greater than 0, a simplified, two-degree-of-freedom seat model is used. Intended for use in simulation of a guided energy-absorbing seat, this model permits the stroking of a rigid seat bucket in a prescribed direction. Because elastic bending of the supporting frame has been observed in testing of

such seats and may influence occupant response, the second degree of freedom is added to simulate rotational elasticity of the frame.

Although the finite element analysis can provide a complete evaluation of a seat's crashworthy performance, the simple stroking seat model can prove useful in other aspects of seat design. For example, the two-degree-of-freedom model can aid in economically estimating the optimum energy absorber limit load for protection of occupants of various size, as well as in evaluating alternative restraint system configurations.

Input data for this seat model include the weight of the movable part of the seat, the direction along which it will stroke, the movement of inertia with respect to a lateral axis, force-deflection characteristics, and unloading slopes.

2.7.3 Finite Element Structural Analysis. The finite element seat model contained in Program SOM-LA uses beam, plate, and spring elements. The beam elements can accommodate large, plastic deformations and localized buckling of elements with hollow cross sections. The program has a capacity for 150 nodes and 450 degrees of freedom. However, a more severe restriction is placed on the size, N , of the master stiffness matrix, given by:

$$N = MEQ + MUD * (2 * MEQ - MUD - 1) / 2 \quad (2)$$

where MUD is the length of the maximum upper diagonal of the banded stiffness matrix given by:

$$MUD = 6 * (J + 1) - 1 \quad (3)$$

MEQ equals the total number of degrees of freedom and J equals the maximum difference between node numbers across elements in the model, as illustrated in chapter 4.

As determined by array dimensions in Program SOM-LA, the quantity N is limited to 11,500.

The finite element seat model in SOM-LA uses a Newmark- β implicit solution algorithm, which is unconditionally stable. However, stability does not necessarily imply convergence to the correct solution, and solution accuracy will depend on the size of the time step, a smaller time step yielding more accurate results. Because the seat step size is governed by that for the occupant model, reducing $DMAX$ and $DMIN$ on line 3 will produce a more accurate solution. However, little improvement can be expected in reducing the seat step size below that normally required for stability in the occupant solution.

Material properties, including a three-slope approximation to the stress-strain curve, are provided on lines 42-44, which must be repeated for each material used. (The number of materials is specified as NUMMAT on line 40.) To assist in input of material properties, summaries of input data for metals typically used in seat frames are presented in Appendix B.

Beam cross sections can be either open or closed, but a plastic problem requires a closed cross section to generate all the terms required by the tangent stiffness matrix. If plastic deformation of an open "I" is anticipated, the cross section can be modeled as a closed "box" beam, which is equivalent for one bending direction, provided that the erroneous properties for other bending directions can be tolerated.

The NUMDIS parameter on line 40 specifies the number of nodes that are attached to the aircraft structure. Then, floor attachment conditions are specified on line 52, one of which must be inserted for each of the NUMDIS nodes. Element cross-sections are described by data on lines 45 and 46, which must be repeated for each cross-section, the number of which is specified by NSECT on line 40.

Nodal coordinates are provided on line 47, which is repeated for each node in the model (NNODE on line 40) and for each beam pointer node (NCOORD on line 40). As illustrated in Appendix A, the pointer node is required to specify the initial orientation of the y-axis of a beam cross section. A real node can be used as a pointer node, or (NCOORD) additional nodes can be added solely to serve as pointers.

3.0 PROGRAM OUTPUT DATA

Program SOM-LA output data are available from the following four sources:

1. Printer (unit 6)
2. Occupant position plots (unit 14)
3. Seat structure plots (unit 20)
4. Plots of other data (unit 26)

which are described further in the following sections.

3.1 PRINTED OUTPUT

Printed data can be selected from the ten blocks listed in section 2.1.4. The interval at which these data are printed is selected in subroutine INPT, based on the total solution time. The interval is sized to provide a maximum of 51 lines for each variable. For example, a solution time between 0.100 and 0.150 sec results in a print interval of 0.003 sec, a solution time between 0.250 and 0.300 sec, an interval of 0.006 sec, etc.

Accelerations, severity indices, vertebral forces and moments, and restraint system forces are printed in tabular and graphical formats. Other data are provided in tabular form only. Acceleration output data are computed each 0.001 sec, equivalent to a 1 KHz sampling rate. Input line 2 provides the option of applying Class 180 (300 Hz) or Class 60 (100 Hz) filter to the data prior to their printing.

3.2 OCCUPANT POSITION PLOTS

If specified in input line 2, data for up to eight plots of occupant position, like that shown in figure 3 can be stored on external file 14. The times for these plots are defined on input line 2A. Viewing angles, illustrated in figure 4, are defined on line 2B. The right-side view of figure 3 was obtained using an angle of zero degrees.

The job control language used in executing SOM-LA must define external file 14 as a permanent file to be saved. The plotting program listed in Appendix E can then be executed using this same permanent file as input (unit 5).

3.3 SEAT STRUCTURE PLOTS

Just as described in section 3.2 for occupant position, data for up to eight plots of the seat structure can be requested on line 2. As shown in figure 5, nodes are indicated and numbered. The

PROGRAM SOM-LA OCCUPANT MODEL
CAMI SERIES 2 - LOW DECELERATION
TIME - 0.0000 SEC.

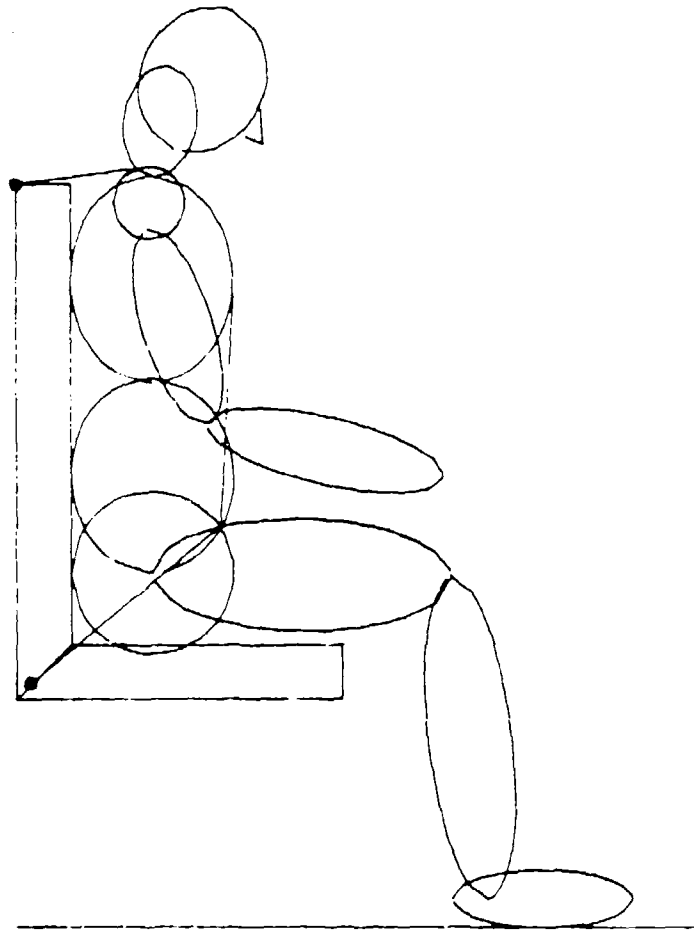

PLT 1 10.40.52 PM 3 207, 1962 .SOM-LA .CAMI SERIES 2 .VER 0.2

Figure 3. Occupant plot at $T = 0$ sec for case no. 1.

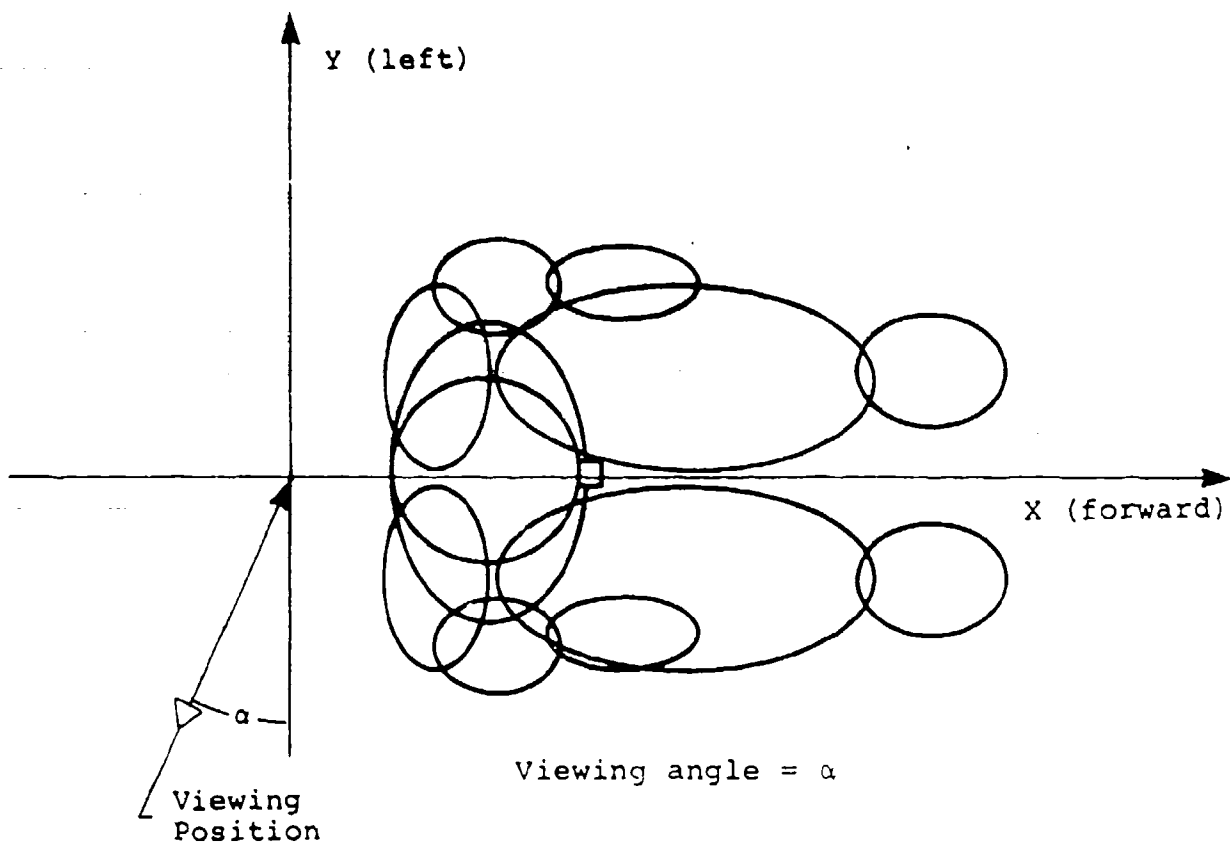

Figure 4. Definition of plot viewing angle.

viewer position for the seat structure is defined by both elevation and azimuth angles, θ and ϕ , respectively, as shown in figure 6. The view of figure 5 was obtained with $\theta = 20$ degree and $\phi = 45$ degree.

The job control language must save external file 20 as input to the plotting program listed in Appendix F.

3.4 ADDITIONAL DATA FOR PLOTTING

Although the printer plots of accelerations and forces are probably satisfactory output for most purposes, there may be cases where plots with a higher level of resolution are desired. Also, pen-drawn plots may be required for use in reports. To meet these needs, 32 variables are written on external file 26 at input-selected intervals. The input parameter DTPLT on line 2 specifies this interval in seconds, and is assumed to be 0.001 sec if DTPLT is left blank. The data are written in either F10.3 or F10.5 format and are arranged as illustrated in figure 7.

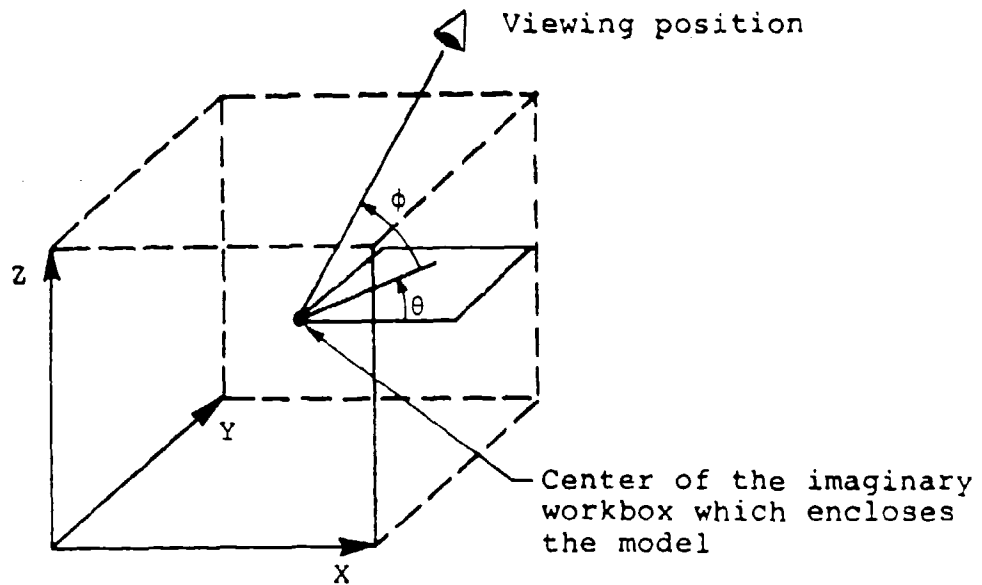

09007 09

θ = Azimuth angle in X-Y plane in degrees ($-180^\circ \leq \theta \leq +180^\circ$)
 ϕ = Elevation angle in degrees ($-90^\circ \leq \phi \leq +90^\circ$)

Figure 6. Angular coordinates for viewing position for seat plots.

1	2	3	4	5	6	7	8
9	10	11	12	13	14	15	16
17	18	19	20	21	22	23	24
25	26	27	28	29	30	31	32

Field	Format	Variable	Field	Format	Variable
1	F10.5	Time (sec)	17	F10.5	Pelvis x-accel (G)
2	F10.5	Aircraft X-accel (G)	18	F10.5	Pelvis z-accel (G)
3	F10.5	Aircraft Z-accel (G)	19	F10.5	Pelvis res. accel (G)
4	F10.5	Aircraft res. accel (G)	20	F10.3	Lumbar axial load (lb)
5	F10.5	Aircraft res. vel. (ft/sec)	21	F10.3	Lumbar y-moment (in.-lb)
6	F10.5	Aircraft res. displ. (in.)	22	F10.3	Neck axial load (lb)
7	F10.5	Seat X-accel (G)	23	F10.3	Neck y-moment (in.-lb)
8	F10.5	Seat Z-accel (G)	24	F10.3	Back cushion force (lb)
9	F10.5	Head x-accel (G)	25	F10.3	Right lap belt force (lb)
10	F10.5	Head z-accel (G)	26	F10.3	Left lap belt force (lb)*
11	F10.5	Head res. accel (G)	27	F10.3	Right shoulder belt force (lb)
12	F10.5	Chest x-accel (G)	28	F10.3	Left shoulder belt force (lb)**
13	F10.5	Chest z-accel (G)	29	F10.3	Tiedown strap force (lb)
14	F10.5	Chest res. accel (G)	30	F10.5	Seat displacement (in.)
15	F10.5	DRI	31	F10.3	Footrest X-force (lb)
16	F10.3	Seat cushion force (lb)	32	F10.3	Footrest Z-force (lb)

*Replaced by energy absorber force (lb) for energy-absorbing seat model (with NSEAT = 0 and SEATM > 0).

**Replaced by seat angular displacement (deg) for energy-absorbing seat model (with NSEAT = 0 and SEATM > 0).

Figure 7. Data format for external file 26.

4.0 INSTRUCTIONS FOR INPUT DATA PREPARATION

This chapter is intended to guide users of Program SOM-LA through an efficient process of preparing input data. The recommended procedure is summarized in table 1. It is suggested that, if time permits, the sample case described in detail in chapter 5 be run initially in order to be certain that the program runs properly on a particular computer system. Storage of plot data on permanent files and subsequent access of these files using the related occupant and seat plot programs should be attempted first with the sample case to assure that the plotting programs are compatible with the computer system and that the job control language is structured properly.

TABLE 1. SUMMARY OF INPUT DATA

1. On sketch of seat, locate aircraft floor and coordinate system. If cockpit interior surfaces are to be represented, they should be located on the same sketch.
 2. Locate restraint system anchor points.
 3. Locate footrest and/or heel position (at $Z = 0$).
 4. Estimate initial position angles for occupant upper torso, head, and arms.
 5. Prepare input data for and run rigid seat case for short time.
 6. Plot occupant initial position and check whether it appears reasonable.
 7. Add seat structure input.
 8. Run short case with complete input data.
 9. Check plot of seat structure at initial time.
 10. Run complete case.
-

The essential starting point for any simulation case is a sketch of the seat of interest, on which the aircraft floor and aircraft coordinate axes can be located. On this sketch the restraint system anchor points, which can be fixed to either the seat or the aircraft structure, can be located, as can the position of a footrest or pedal, if applicable. The required seat design data for a rigid seat case, i.e., the locations and dimensions of the seat pan and back, can then be determined. Both the seat cushion and back cushion are assumed to be plane surfaces parallel to the seat pan and back surfaces. Using an average cushion thickness in the

area of contact between the occupant and the seat, the cushion surfaces can now be added to the sketch.

Initial angular positions of the torso, head, and arm segments are required. The torso segments can be assumed parallel to, or one or two degrees forward of, the seat back. The position of the head, in a normal seated position, would range from vertical to several degrees forward of vertical, as illustrated in the chapter 5 sample case.

In order to be certain that the occupant initial position is reasonable for the configuration being studied, it is wise to run a short rigid seat case prior to adding the seat structure input. Starting with a small value of final time, TF, on line 3, such as 0.010 sec, the initial position and accelerations of the occupant segments and the external forces can be checked prior to initiating a more expensive case. The plot data saved on unit 14 by SOM-LA can then be input to the occupant plot program and the initial position of all the occupant segments reviewed. If the occupant's initial position, as calculated by subroutine INITIL, is geometrically impossible, the program will be stopped and informative messages printed. An example of this type of error, commonly encountered in initially running a case, is in attempting to locate the heel position beyond the reach of the legs. If the input parameters yield a geometrically feasible initial position and NOPLOT > 0 on line 2 and TPLOT = 0 on line 2A, then data for a plot of the initial position will be stored.

Once the desired initial position has been achieved for the occupant, the input data for the finite element seat structure model can be added. The NSEAT parameter on line 1 should then be changed from 0 to 1 to signify modeling a nonrigid seat. Once again, prior to running a complete simulation, a case with a small TF should be run in order to check the seat structure plot at the initial time.

When it has been determined that both the occupant initial position and the seat structure configuration are as desired, a complete simulation case can be run. The user should take care that the TMAX parameter in decimal seconds on line 3 corresponds to the time allotted for the run in the job control language (which may be an octal number). Within the program, an allowance is made for printing of the stored output data. Should the run be terminated at TMAX prior to the solution reaching completion at TF, the output data already generated will be printed, including the final generalized coordinates, which can be used in restarting the solution.

5.0 SAMPLE SIMULATION CASES

In this chapter are presented descriptions of input data preparation for simulation of impacts involving three different seats. The first case involves testing of a simple seat structure, which was used as part of the validation of the SOM-LA structural model. Preparation of input data for this first case is covered in detail, and a second case, which involves a more complex production-type general aviation seat, focuses on data for the seat model. Then, simulation of an energy-absorbing helicopter seat with the NSEAT = 0 option is described. Finally, input data for the secondary impact option are described.

5.1 CASE NO. 1: DYNAMIC TEST OF STRUCTURALLY SIMPLE SEAT

Two series of deceleration sled tests were performed at the FAA Civil Aeromedical Institute (CAMI) to provide data for validation of Program SOM-LA. The tests utilized an Alderson VIP-50 dummy in forward-facing test seats. The test program is described in reference 1, which includes a summary of measured data.

The first series of tests used a rigid seat pan and seat back assembly, supported by solid, rectangular cross-section legs and seat back hinges. The second series of validation tests used a similar rigid seat pan and back, braced at a 90-degree included angle, as illustrated in figure 8. The seat legs were 1-in. diameter, 0.068-in. wall thickness steel tubing, pin jointed at the bottom, and fixed at the seat. Cushions were 1-in. thick Ensolite pads on the seat pan and back, and the restraint system consisted of a conventional nylon lap belt attached to the seat pan with a double shoulder belt that was anchored to the seat back and fitted to the buckle at the center of the lap belt. For all tests, the belts were adjusted to a snug fit with all slack removed. For each of these seat designs, two impact-vector orientations were used. The first orientation provided pure forward-facing (-G_x) acceleration. The second orientation provided combined longitudinal (-G_x) and vertical (+G_y) acceleration by reorienting the seat system so that the impact vector fell 60 degrees below the floor plane of the seat. For the seat design with tubular legs, eight static tests and 58 dynamic tests, which used acceleration levels of 5.4 G and 9.5 G, were conducted. For the dynamic tests, the lower acceleration level provided minimal plastic deformation of the seat legs without significant cross section change, while the higher acceleration level produced marked plastic deformation with localized buckling and cross sectional change at the fixed end. For the tests with the angled floor, acceleration levels of 13.5 G and 22 G were required to produce similar results. The impact velocity for all of the these tests was approximately 44 ft/sec.

The test series selected for use in this sample case is the lower deceleration, forward-facing (-G_x) series, for which data from 10 tests were provided by the CAMI Protection and Survival Laboratory. Pre- and posttest photographs from one of the 10 tests are

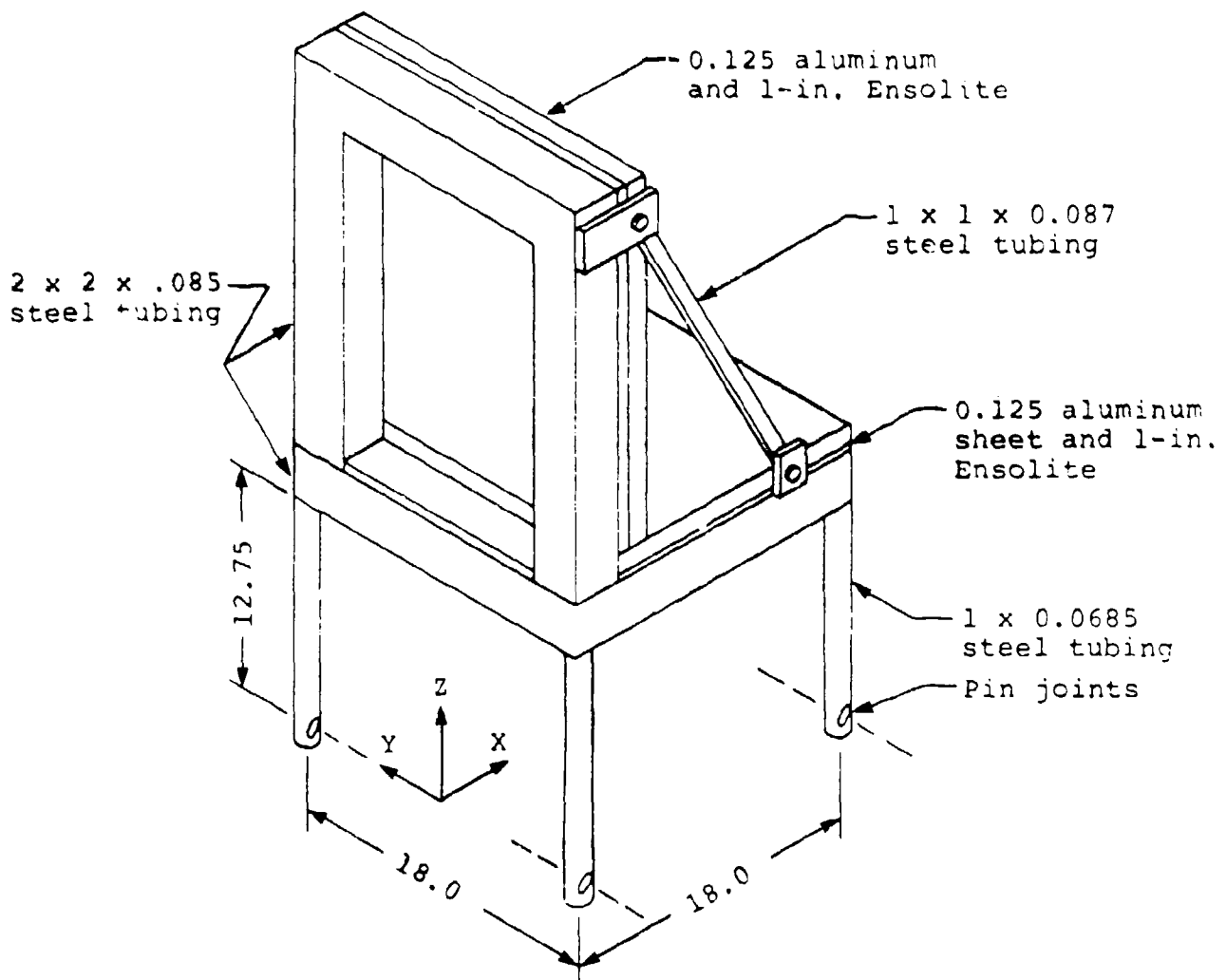

NOTE: All dimensions in inches.

Figure 8. CAMI Series 2 test seat.

shown as figures 9 and 10. The permanent deformation at the top of the legs can be seen in the latter photograph. The test configuration is illustrated in figure 11, which includes several dimensions required for input data, and the input deceleration is shown in figure 12.

It should be noted in figure 11 that the aircraft coordinate system has been placed on the aircraft floor so that the X axis is directed forward relative to the seat and the X-Y plane lies on the floor. Although the coordinate system can be placed anywhere on the floor, locating it on a plane of symmetry, such as the centerline of the seat, facilitates interpretation of data. All coordinates required for input are then measured in this reference system.



Figure 9. CAMI Series 2, lower-deceleration, forward-facing test, pretest.



Figure 10. CAMI Series lower-deceleration, forward-facing test, posttest.

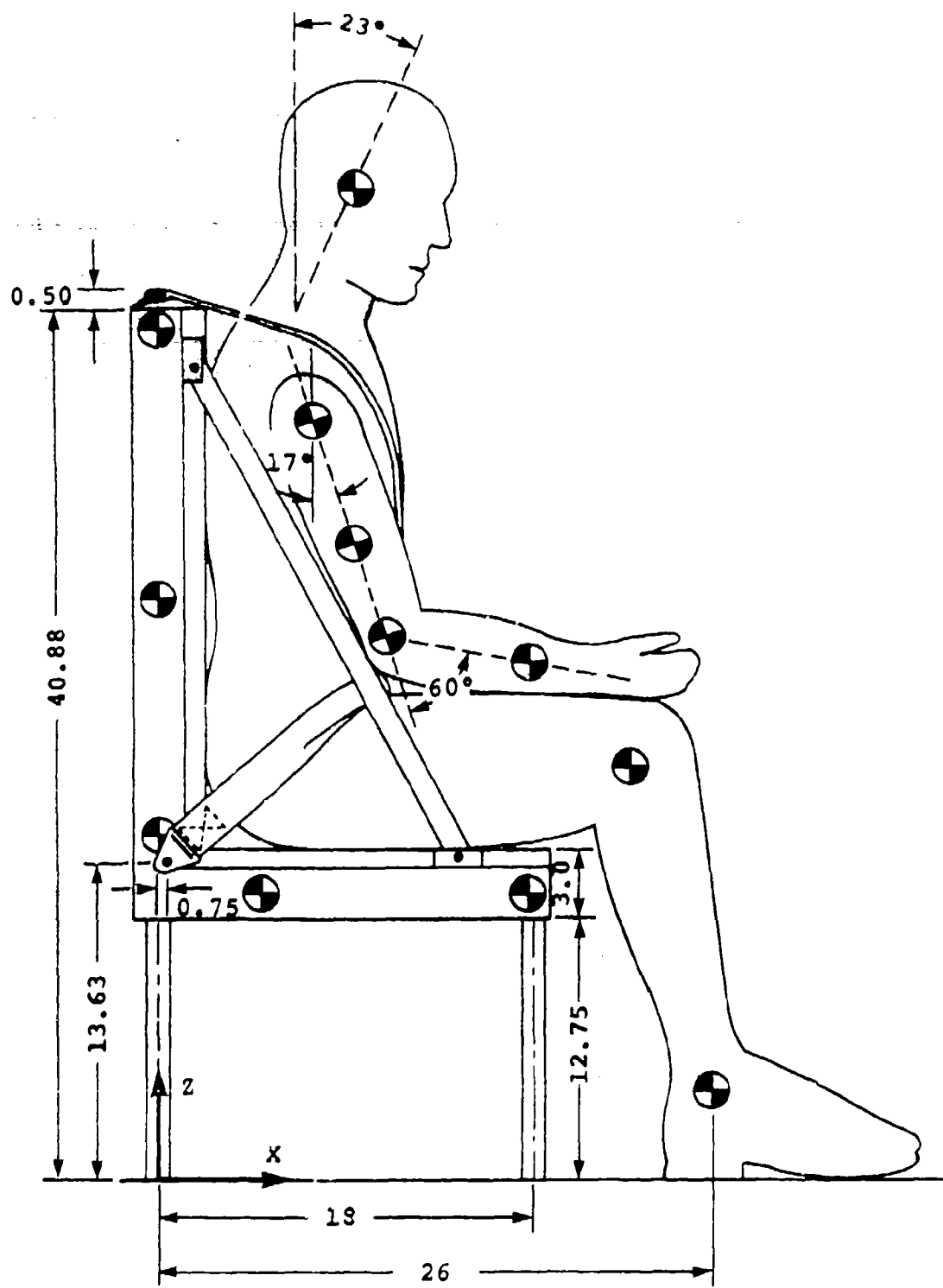

Figure 11. Test configuration, CAMI Series 2, lower-deceleration, forward-facing tests.

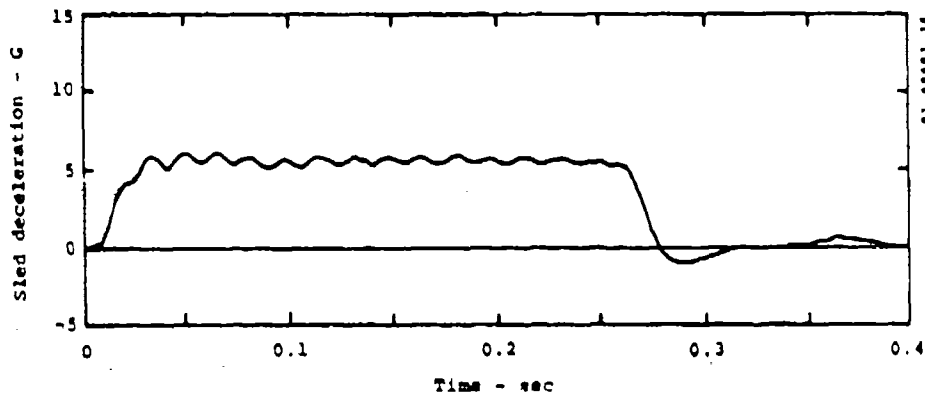

Figure 12. Sled deceleration, CAMI Series 2, lower-deceleration, forward-facing test.

Input data are discussed below, line by line, and a complete input listing is presented subsequently as figure 17. Output data are then discussed in section 5.1.2, and examples of plots are presented there. The contents of Appendix A show explicit input requirements for this case.

5.1.1 Case No. 1 Input Data (detailed listing in Appendix A)

- Line 1: Descriptive title; NUNIT = 1 for English units; NSEAT = 1 for finite element seat; NDIM = 2 for two-dimensional simulation.
- Line 2: IOUT(1) = 1 and IOUT(2) = 1 request segment position and velocity data; IOUT(3) = 2 requests occupant segment acceleration, filtered with class 180 digital filter; IOUT(5) = 1 requests restraint system forces; IOUT(6) = 1 requests spinal loads and injury criteria; IOUT(7) = 2 requests seat external loads filtered with a class 60 digital filter; IOUT(8) = 1, IOUT(9) = 1, and IOUT(10) = 1 request seat structure deflection, support reactions, and stresses, respectively; NOPLOT = 8 for 8 occupant position plots; NSPLOT = 8 for 8 seat structure plots; DTPLT = 0.0005 determines the interval at which the data described in section 3.4 are written on unit 26; TSEAT = 0.005 indicates the output data print interval for the seat. CKPTIN and ICPFL are not specified since restart is not anticipated.
- Line 2A: Occupant plot data to be stored at $t = 0, 0.040, 0.080, 0.120, 0.160, 0.200, 0.240, 0.280$ seconds.

- Line 2B: Occupant plot data to be stored with viewing angle of 0 degrees for all plots, i.e., right-side view.
- Line 2C: Seat structure plot data to be stored for all plots with +20-degree elevation angle.
- Line 2D: Seat structure plot data to be stored for all plots with +45-degree azimuth angle, i.e., viewed from left-front quarter.
- Line 2E: Nodal output data requested for nodes 1 through 16. (See figure 13 for node designations.)
- Line 2F: Stress output data requested for elements 1 through 6. (See figure 13 for element designations.)
- Line 3: TMAX = 900 to allow up to 900 seconds central processor time for this example, on a CDC Cyber 175 system; DMAX and DMIN set to 0.0005 sec for fixed time step integration; integration error bounds, EUR, and ELR, set at 10 and 0.1 percent, respectively; TI = 0 and TF = 0.300 sec; initial step size, DTI, is same as fixed step size. (If DMAX is not the same as DMIN, DTI should be set equal to DMIN.)
- Line 4: Combined seat bottom cushion and occupant buttocks force-deflection relationship of the form $F = 375(e^{0.653\delta} - 1)$, as shown in figure 14; damping coefficient of 0.85 at zero load. Although the cross sections of the beams that support the cushion are utilized in forming element stiffnesses, their dimensions do not contribute to determining the height of the cushion above the floor. If the actual 1.0-in. cushion thickness were used here, the dummy would be seated 2 in. too low. Therefore, a 3.0-in. cushion thickness is used as input, to account for the 2.0-in.-deep box beams.
- Line 5: Seat back cushion properties with same load-deflection curve as bottom cushion. As on the previous line, a 3.0-in. thickness is used to account for the 2.0-in. beam thickness and seat the dummy in the correct fore-and-aft position.
- Line 6: IRSYS = 3 for double shoulder harness; ILPBLT = 1 and ISHRNS = 1 for lap belt and shoulder harness attached to seat; no headrest.
- Line 7: Forces and strains for 2-in. nylon webbing; zero damping; no slack.

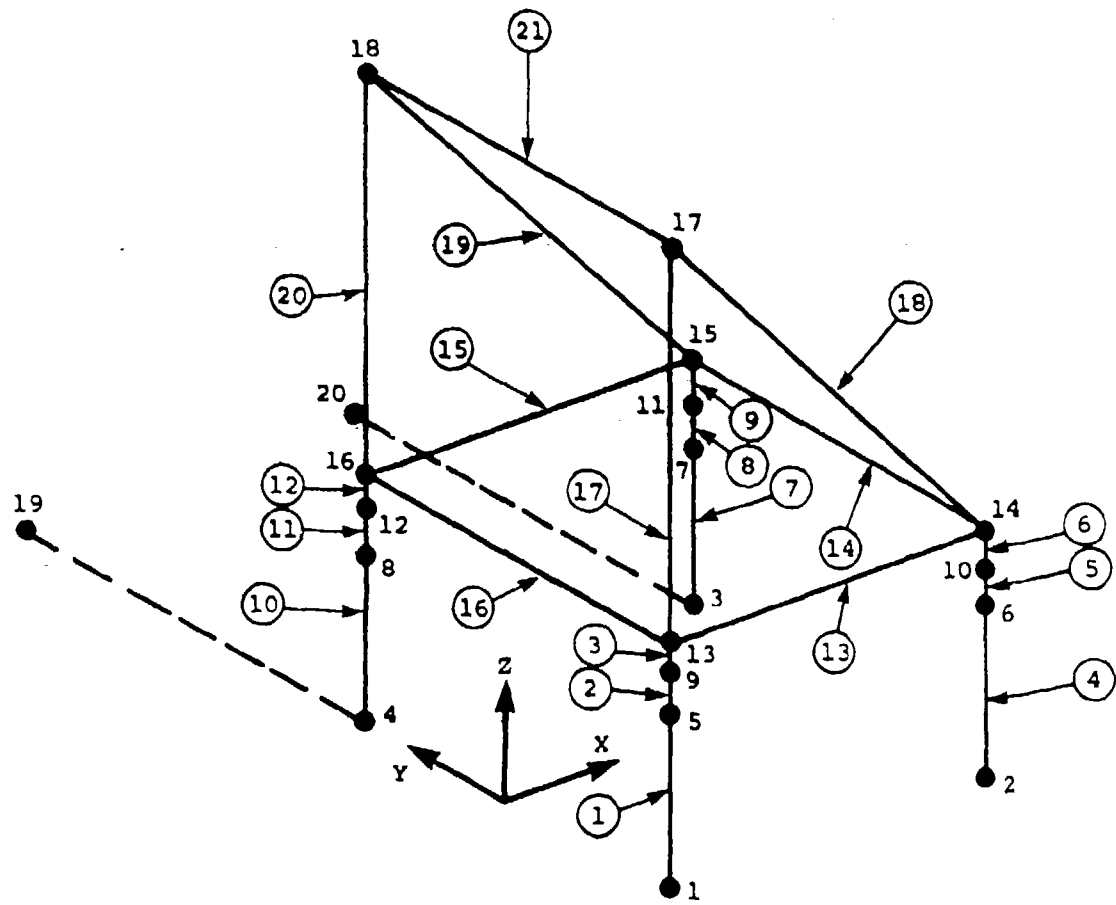

1, 2, 3, ..., 20 Node numbers
 (1), (2), (3), ..., (21) Element numbers

Figure 13. Finite element seat model.

- Line 8: Anchor point coordinates for lap belt; no footrest.
- Line 9: Same as line 7.
- Line 10: Anchor point coordinates for shoulder belts.
- Lines 11-34: The measured sled deceleration pulse is approximated by a series of straight lines, and 10 points in acceleration and time are measured on the plot, as shown in figure 15. Note that accelerations in the coordinate directions are required so that the deceleration pulse of figure 10 results in negative X values. Because there are no Y- or Z-accelerations, lines 15-22 are blank; the absence of vehicle rotations requires lines 23-34 to be blank.

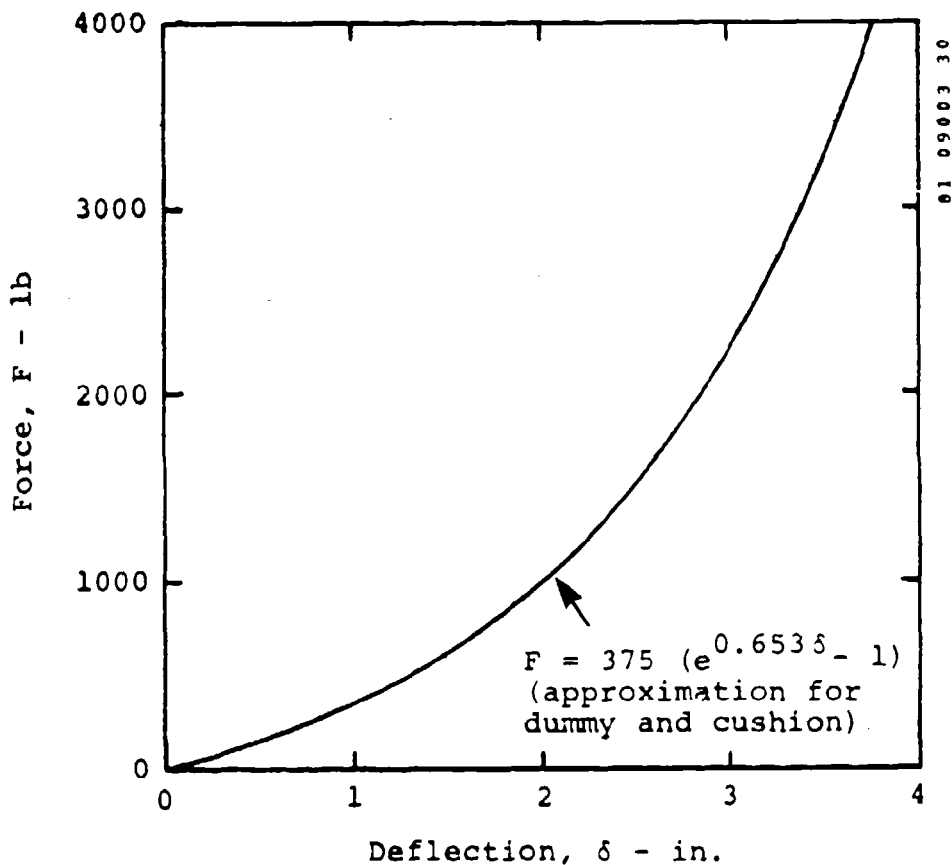

Figure 14. Exponential approximation to force-deflection characteristics for dummy and 1-in.-thick cushion.

- Line 35: Initial velocity = 44.18 ft/sec in the X-direction.
- Line 36: Initial position of "aircraft" in inertial coordinate system is assumed to be (0., 0., 0.).
- Line 37: IMAN = 3 requests nonstandard dummy model; seat cushion and floor friction coefficients are 0.19 and 0.25, respectively.
- Line 38: GAM(1) and GAM(2) = 0 degrees; GAM(3) = 23 degrees for head measured on photograph of pretest configuration; GAM(4) = -17 degrees for upper arms; GAM(5) = 60 degrees at elbow; heels at 26 in. (These coordinates are illustrated in figure 6).

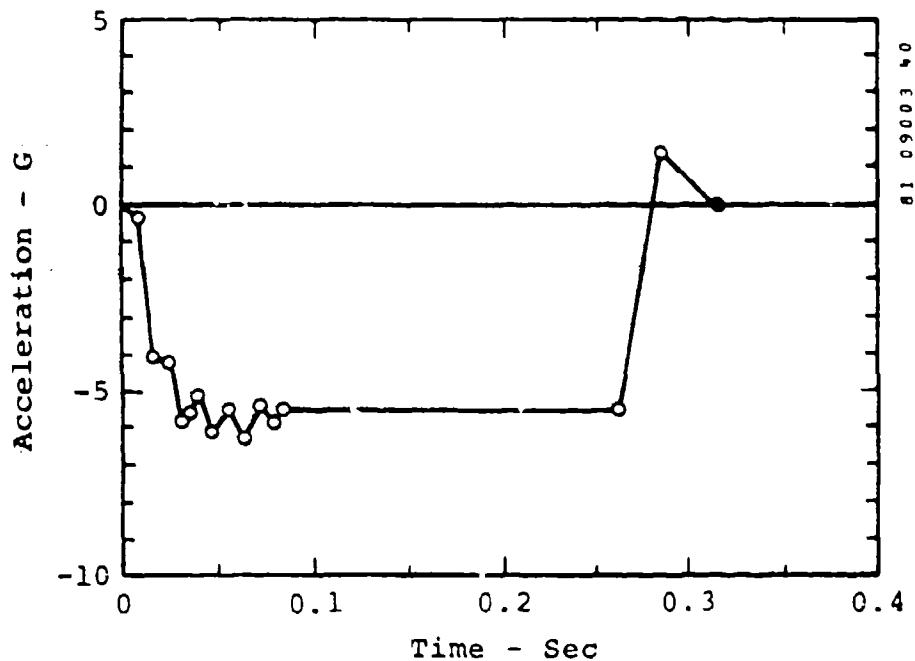

Figure 15. Approximation to sled acceleration.

Lines 38A-38L: Nonstandard occupant segment dimensions, weights, moments of inertia, and damping coefficients. For this example, in order to illustrate the nonstandard occupant input, or IMAN = 3 on line 37, and properties of the standard (Part 572) dummy are included.

Line 39: Coordinate system was located under rear edge of seat, so that XSEAT = 0; seat pan and back angles are 0; seat pan and back angles are 0. The length and width of the seat pan are 18 in., as is the back width. The height of the seat pan (actually, the top of the legs) and top of seat back are 12.75 and 40.88 in., respectively.

Line 40: The finite element seat model is illustrated in figure 8. NNODE = 18 (real nodes); NELE = 21; NUMMAT = 1 for one material; NUMDIS = 4 (displacement-specified nodes on floor); NCOORD = 2 (beam pointer node, described in section 2.7.3 and Appendix A - numbered 19 and 20); and NSECT = 3 for three beam element cross sections. The buckling coefficient has the standard value of 0.5.

Line 41: KNTRL(1) = 1 indicates that the stiffness matrix will be updated every cycle after plastic yielding of any element has been initiated.

Lines 42-44: Material type No. 1 is 1010 steel with $S_y = 58,700$ psi and $S_{ult} = 67,000$ psi.

- Lines 45-46: There are three groups for the three cross sections (NSECT = 3) shown in figure 16. The circular tubing cross section, defined first, is made up of eight plate segments; the rectangular and square cross sections, four each. The orientation of the cross section is specified by the beam pointer node, which locates the y-axis, as described in section 2.7.3.
- Line 47: Twenty lines for the nodes illustrated in figure 13, including the beam pointer node.
- Line 48: Twenty-one lines for the elements illustrated in figure 13.
- Line 49: Seat cushion load to be distributed on nodes 13, 16, 14, and 15 (rear edge first).
- Line 50: Back cushion load to be distributed on nodes 13, 16, 17, and 18 (bottom edge first).
- Line 51: Lap belt anchored to nodes 13 and 16 (right side first); shoulder harness load shared by nodes 17 and 18.
- Line 52: Four lines, which specify the constraint conditions at the bottom of the seat leg elements, indicate that moments can be supported about the X- and Z-axes, but not the Y-axis.

A complete listing of the input data is presented in figure 17.

5.1.2 Case No. 1 Output Data. A listing of output data for the case described in 4.1.1 is presented in Appendix C. Examples of plots generated by this case are presented as figures 18 and 19. Listings of the occupant and seat plotting programs are presented in Appendices E and F, respectively. Both of these programs use the DISSPLA (Display Integrated Software System and Plotting Language), described in reference 2.

5.1.3 Case No. 1 Computer Resource Requirements. This 0.300-sec simulation of the CAMI dynamic test of a structurally simple seat required 425 central processor seconds on a Control Data Corporation Cyber 175 computer system. Required computer memory was 114,000 (decimal) words.

5.2 PRODUCTION GENERAL AVIATION SEAT

Front and side views of the production general aviation seat treated here as an example are shown in figure 20. Note that the coordinate system has been placed on the floor at the centerline of the seat far enough aft that all points on the seat will be positive. Although this is not a requirement, such location of the coordinate system does facilitate preparation of input data.

Actual Cross-Section

Model of Cross-Section

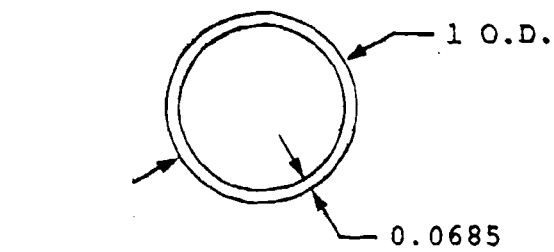

Type 1

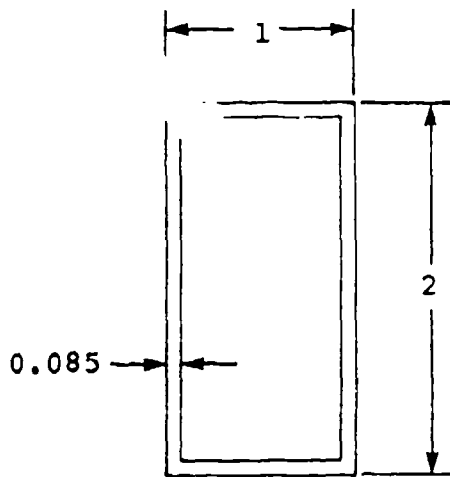
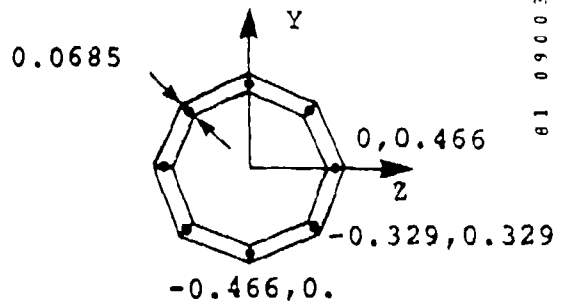

Type 2

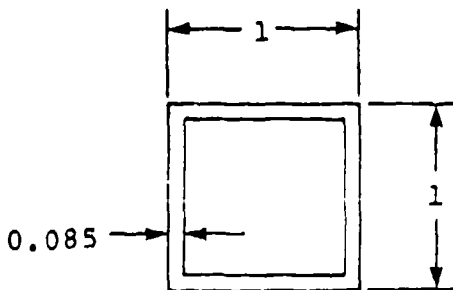
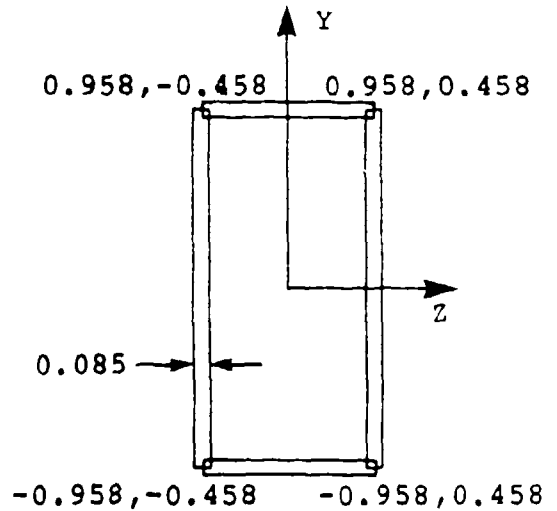

Type 3

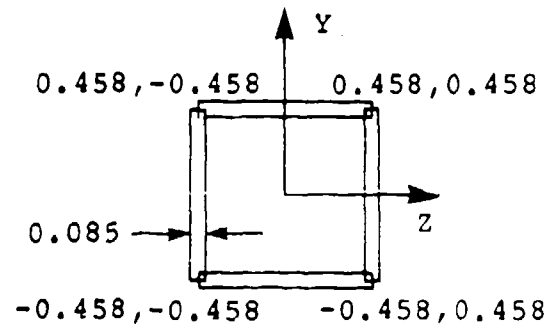

NOTE: All dimensions in inches.

Figure 16. Element cross-section models used for seat structure beam elements.

81 09003 03

CAMI SERIES 2 - LOW DECELERATION										
	1	2	0	1	1	2	1	1	1	2
1	1			1	1				8	8.0005.0050
	0.	.040	.080	.120	.160	.200	.240	.280		
	0.	0.	0.	0.	0.	0.	0.	0.		
	20.0	20.0	20.0	20.0	20.0	20.0	20.0	20.0		
	45.0	45.0	45.0	45.0	45.0	45.0	45.0	45.0		
1	16									
1	6									
	300.	0.0005	0.0005	0.10	0.001	0.	0.300	0.0005		
	375.	.653	.85	3.00						
	375.	.653	.85	3.00						
3	1	1	1	0						
	550.	1300.	2250.	0.0403	0.1048	0.1613	00.00	0.		
	0.75	-9.	13.63	0.75	9.	13.63	28.	0.		
	550.	1300.	2250.	0.0403	0.1048	0.1613	00.00	0.		
	0.	0.	41.38	12.	0.					
	0.	-0.16	-4.04	-4.20	-5.91	-5.75	-5.05	-6.14		
	-5.44	-6.22	-5.36	-5.83	-5.44	-5.44	1.32	0.		
	0.	.008	.018	.025	.031	.036	.040	.048		
	.057	.065	.072	.080	.084	.263	.283	.314		

44.18	0.	0.	0.	0.	0.	0.		
0.	0.	0.	0.	0.	0.	0.		
3	0.18	0.25						
164.38	69.1	0.	0.	23.	-17.	60.	26.	
10.85	8.35	11.3	13.3	16.5	18.0			
4.67	6.550	6.330	4.720	6.260	8.350	10.96		
34.60	35.97	10.10	4.85	4.85	21.70	9.49	1.98	
2.32	2.18	.275	.132	.017	.127	.927		
0.76	0.93	.266	.135	.185	1.22	.994	.0177	
2.32	1.70	.237	.022	.195	.873	.505		
4.50	4.50	3.44	1.95	1.85	3.10	2.30	2.30	

Figure 17. Listing of input data, case no. 1.

1.50	3.56	2.61	1.85	2.34			
3.70	6.34	0.20	0.20	2.00			
2000.	.050	2000.	.380				
6000.	.236	1.00	3240.	.270	1.0		
375.0	1.49	150.	375.0	1.49	30.0		
0.	12.75	0.	0.	18.	18.	40.88	18.
18 21	1 4	6 2	3 0.50				
1							
11010 STEEL							
7.324-04	30.E6	58700.	2.9E5	.1	67000.	.3	.03
		62500.	75000.				
8 0	.0219	.0219					
-.466	0.	.0685					
-.329	-.329	.0685					
0.	-.466	.0685					
.329	-.329	.0685					
.466	0.	.0685					
.329	.329	.0685					
0.	.466	.0685					
-.329	.329	.0685					
4 0	.243	.080					
-.958	-.458	.085					
-.958	.458	.085					
.958	.458	.085					
.958	-.458	.085					
4 0	.0249	.0249					
-.458	-.458	.085					
-.458	.458	.085					
.458	.458	.085					
.458	-.458	.085					
1	0.0	-9.0	0.0				
2	18.0	-9.0	0.0				
3	18.0	9.0	0.0				
4	0.0	9.0	0.0				
5	0.0	-9.0	9.75				
6	18.0	-9.0	9.75				
7	18.0	9.0	9.75				
8	0.0	9.0	9.75				
9	0.0	-9.0	11.75				
10	18.0	-9.0	11.75				
11	18.0	9.0	11.75				
12	0.0	9.0	11.75				
13	0.0	-9.0	12.75				
14	18.0	-9.0	12.75				
15	18.0	9.0	12.75				
16	0.0	9.0	12.75				
17	0.0	-9.0	41.38				
18	0.0	9.0	41.38				
19	0.0	22.0	0.0				
20	18.0	22.0	0.0				

Figure 17 (contd). Listing of input data, case no. 1.

1	1	5		1	4	2	1
2	5	9		1	4	2	1
3	9	13		1	4	2	1
4	2	6		1	3	2	1
5	6	10		1	3	2	1
6	10	14		1	3	2	1
7	3	7		1	20	2	1
8	7	11		1	20	2	1
9	11	15		1	20	2	1
10	4	8		1	19	2	1
11	8	12		1	19	2	1
12	12	16		1	19	2	1
13	13	14		2	1	2	1
14	14	15		2	2	2	1
15	15	16		2	3	2	1
16	16	13		2	4	2	1
17	13	17		2	14	2	1
18	14	17		3	15	2	1
19	15	18		3	14	2	1
20	16	18		2	15	2	1
21	18	17		2	16	2	1
13	16	14	15				
13	16	17	18				
13	16	17	18				
1111101							
2111101							
3111101							
4111101							

Figure 17 (contd). Listing of input data, case no. 1.

PROGRAM SOM-LA SEAT STRUCTURE MODEL
CAMI SERIES 2 - LOW DECELERATION
PLOT NO. 7, TIME - .2400 SEC.

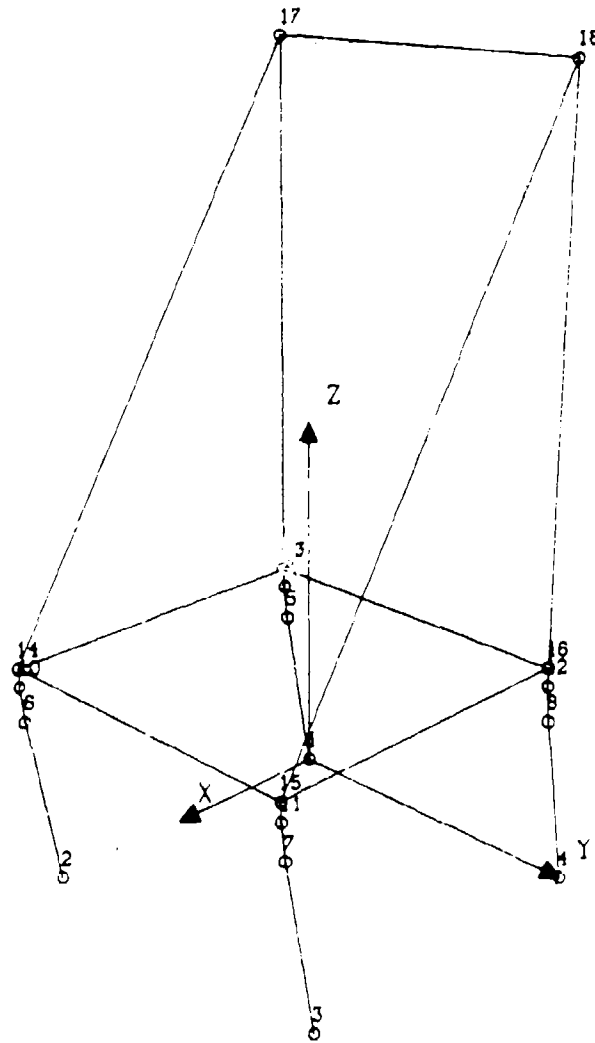

PLOT 7 10.11.00 TIMES 7 SEP, 1962 DEFORMATION - USE FROM DISPLACEMENT 1.2

Figure 19. Seat plot at $T = 0.240$ sec for case no. 1.

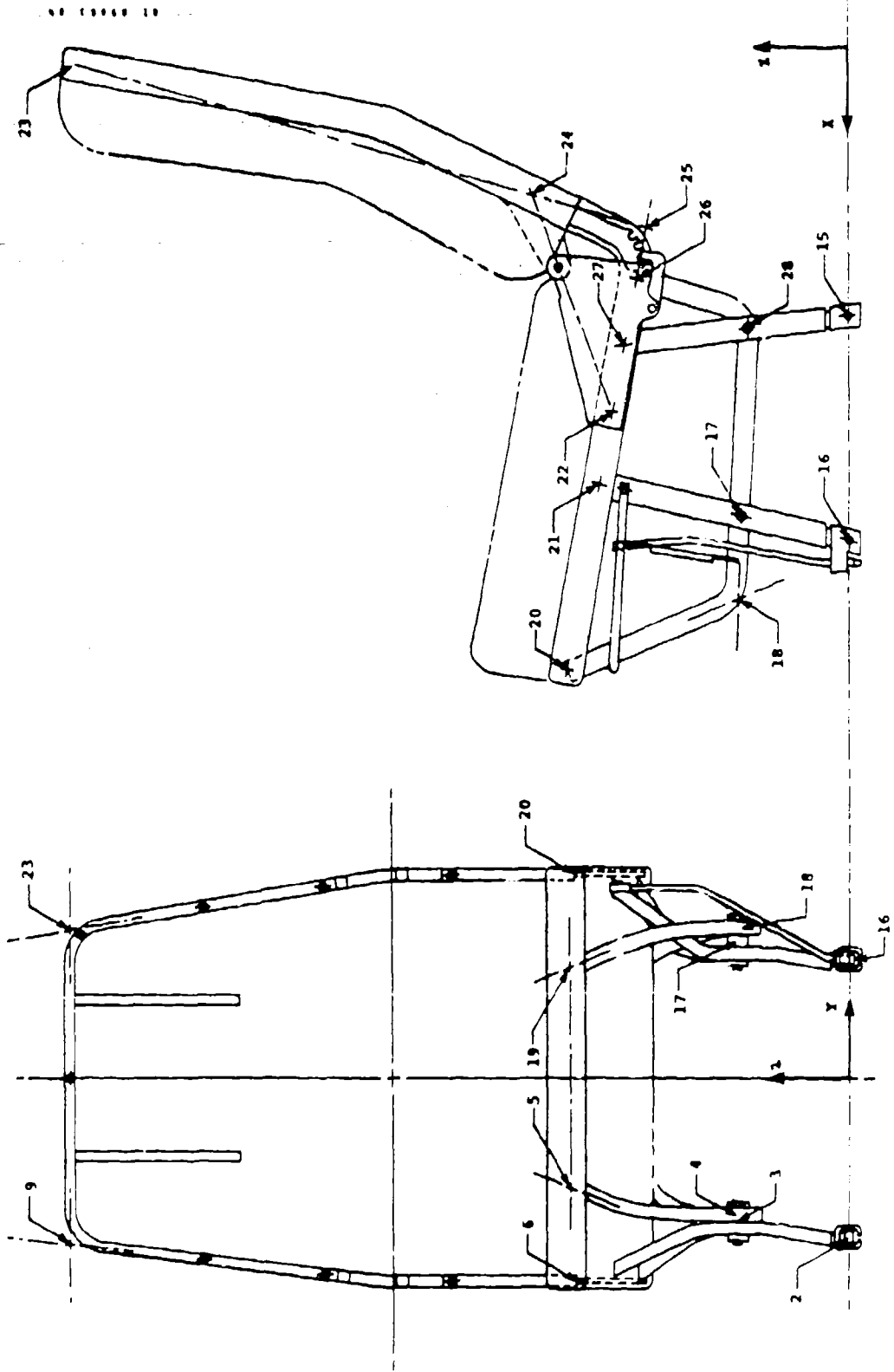

Figure 20. Production general aviation seat (with some node numbers indicated).

Because of the nonsymmetric restraint system, a three-dimensional occupant simulation is requested by NDIM = 3 on line 1. As illustrated in figure 21, the seat structure was modeled using 28 nodes, 36 beam elements, and 2 plate elements. The seat structure is fabricated of 6061-T6 aluminum alloy. The cross section of all beam elements is illustrated in figure 22 along with the rectangular approximation utilized in the model. A listing of input data is presented as figure 23. Because neither the lap belt nor the shoulder harness is attached to the seat, the restraint system nodes are not required. The seat has one fore-and-aft adjustment locking pin at the left-front track connection. The track connections are assumed to constrain nodes 1, 2, and 15 against translation in the Y and Z direction but free in the other directions. Node 16, on the other hand, where the adjustment locking pin is located, is constrained in all directions except Z rotations. Some judgment is required as to the ability of the adjustment locking pin to resist rotations about the X or Y axes.

This model nearly fills the master stiffness matrix array which is dimensioned 11,500, as described in Section 2.7.3. Referring to Equations (2) and (3), for 28 nodes and 6 degrees of freedom at each,

$$MEQ = (6)(28) = 168$$

As shown in figure 21, the maximum difference between node numbers across any element is

$$J = 14$$

Then

$$MUD = 6(14 + 1) - 1 = 89$$

and

$$\begin{aligned} N &= 168 + 89[(2)(168) - 89 - 1]/2 \\ &= 11,115 \end{aligned}$$

which is nearly at the dimension of 11,500.

5.3 ENERGY-ABSORBING HELICOPTER SEAT

A production energy-absorbing helicopter seat was tested at CAMI. The test configuration is illustrated in figure 24. A complete listing of input data is presented as figure 25.

Headrest properties are provided on line 6A. In addition to lap belt and shoulder belt properties and locations on line 7-10, the lap belt tiedown strap is described on lines 10A and 10B. The webbing is a low-deflection polyester type, whose load-elongation properties are illustrated in figure B-5. A five-point restraint system was used, as indicated by IRSYS = 4 on line 6.

PLOT NO. 1, TIME - 0.0000 SEC.

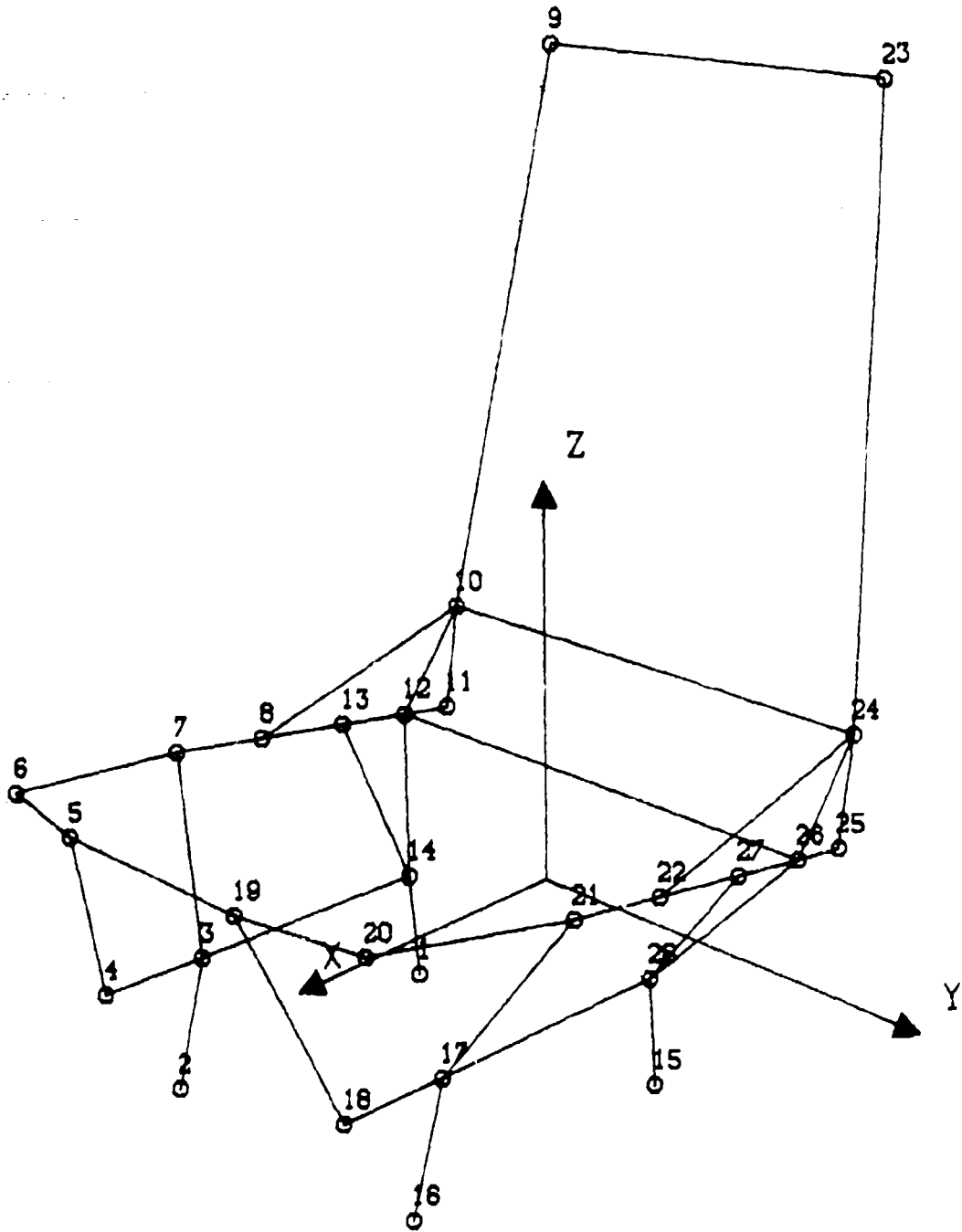
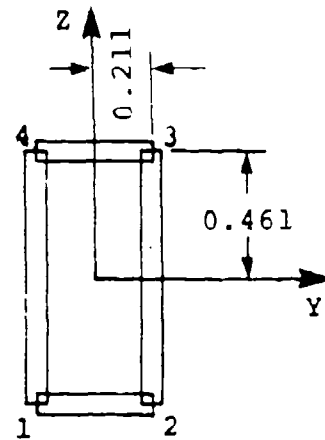
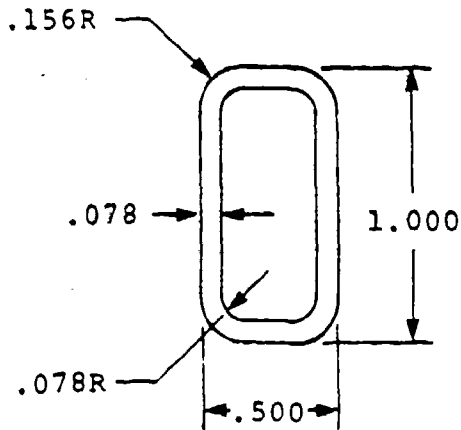

Figure 21. Finite element model of production seat.

Actual Cross Section

Approximate Cross Section



$$A = 0.1940 \text{ in.}^2$$

$$I_y = 0.02078 \text{ in.}^4$$

$$I_z = 0.00672 \text{ in.}^4$$

	Y	Z
1	-0.211	-0.461
2	0.211	-0.461
3	0.211	0.461
4	-0.211	0.461

Figure 22. Beam element cross section.

As shown in figure 24, the seat was rotated on the horizontal sled in order to simulate a near-vertical impact. The input acceleration is input in both x- and z-components, on lines 11-14 and 19-22, respectively. The pitch of -73 degrees is entered on line 36.

Energy absorber data are centered on line 40. The load-stroke characteristics for the seat are illustrated in figure 26. The guide tubes shown in figure 24 are oriented 4 degrees from the z-axis, and this angle is input on line 40, along with the movable seat weight of 60.6 lb. It is this nonzero seat weight that causes the stroking seat model to be used.

Line 41 includes the unloading slope of 4308 lb/in. and the damping coefficient of 0.55 lb-sec/in., which was determined by matching the measured energy absorber force-time history. A moment of inertia of 148 lb-in.-sec² with respect to the aircraft coordinate system was estimated for the seat. Rotational stiffness parameters were estimated from static tests of the seat.

5.4 EXAMPLE OF COCKPIT GEOMETRY

The secondary impact option, specified by input of IOU(4) = 1 on line 2, permits output of velocities at which occupant segments strike the interior of the aircraft and the time at which each

NONADJUSTABLE PILOT SEAT 12-G FORWARD TEST AB1-110															
1	0	2	0	1	1	2	1	1	1	8	8.0005	0.005	1	1	3
	0.		.040		.080		.120		.160		.200		.240		.280
	0.		0.		0.		0.		0.		0.		0.		0.
	20.0		20.0		20.0		20.0		20.0		20.0		20.0		20.0
	45.0		45.0		45.0		45.0		45.0		45.0		45.0		45.0
1	28														
1	36														
	2048.		.0005		.0005		.10		.001		0.		.300		.0005
	197.2		0.7		.87		2.								
	197.2		0.7		.87		2.								
2	1	0	0	0	0										
	550.		1300.		2250.		.0403		.1048		.1613		0.00		0.
	7.5		-9.50		.5		7.5		9.50		.5		38.0		45.
	550.		1300.		2250.		.0403		.1048		.1613		0.00		0.
	-16.		15.75		46.		13.25		0.						
	0.		-0.109		-8.93		-10.9		-11.9		-11.6		-12.4		-12.2
	-10.7		-11.1		-9.29		-11.6		-9.59		3.47		0.952		0.
	0.		.0092		.0262		.0330		.0389		.0420		.0550		.0716
	.0805		.0933		.1000		.1463		.1592		.1688		.1750		.2180
	49.7		0.		0.		0.		0.		0.				
3	0		.25		.25										
	164.38		69.1		-8.4		-8.4		0.		-30.		37.		38.0
	10.85		8.35		11.3		13.3		16.5		18.0				
	4.67		6.550		6.330		4.720		5.260		8.350		10.96		
	34.60		35.97		10.10		4.85		4.85		21.70		9.49		1.98
	2.32		2.18		.275		.132		.017		.127		.927		
	0.76		0.93		.266		.135		.185		1.22		.994		.0177
	2.32		1.70		.233		.022		.195		.873		.505		

Figure 23. Input data listing case no. 2.

4.50	4.50	3.44	1.95	1.85	3.10	2.30	2.30
1.60	3.56	2.61	1.85	2.34			
3.70	6.34	0.20	0.20	2.00			
4000.	.500	2000.	0.38				
6000.	.238	1.00	3240.	.270	1.0		
375.0	1.49	150.	375.0	1.49	30.0		
4.67	7.93	9.2	8.4	15.3	15.8	29.2	12.2
28	38	1	4	5	4		
1		250	0	3			
16061-T6 AL							
.2588E-4	10.E6	36000.	1.E6	.162	45000.	.3	
		42000.	18750.				
4	0	.02078	.00672				
	-.211	-.461	.078				
	.211	-.461	.078				
	.211	.461	.078				
	-.211	.461	.078				
1		8.0	-5.0	0.			
2		17.9	-5.0	0.			
3		17.0	-5.00	4.16			
4		20.5	-5.00	4.29			
5		23.0	-3.3	10.9			
6		22.1	-7.0	10.76			
7		15.82	-7.9	9.75			
8		12.53	-7.9	9.21			
9		1.50	-6.1	29.2			
10		4.15	-7.9	11.3			
11		4.67	-7.9	7.93			
12		6.57	-7.9	8.24			
13		9.22	-7.9	8.68			
14		8.57	-5.00	3.87			
15		8.0	5.0	0.			
16		17.9	5.0	0.			
17		17.0	5.00	4.16			
18		20.5	5.00	4.29			
19		23.0	3.3	10.9			
20		22.1	7.0	10.76			
21		15.82	7.9	9.75			
22		12.53	7.9	9.21			
23		1.50	6.1	29.2			
24		4.15	7.9	11.3			
25		4.67	7.9	7.93			
26		6.57	7.9	8.24			
27		9.22	7.9	8.68			
28		8.57	5.00	3.87			
29		8.57	0.	3.87			
30		17.0	0.	4.16			
31		23.0	0.	10.9			
32		4.67	0.	7.93			

Figure 23 (contd). Input data listing case no. 2.

1	1	14		1	29	2	1
2	2	3		1	30	2	1
3	14	3		1	29	2	1
4	3	4		1	30	2	1
5	4	5		1	31	2	1
6	5	6		1	31	2	1
7	6	7		1	31	2	1
8	7	8		1	31	2	1
9	8	13		1	32	2	1
10	12	13		1	32	2	1
11	3	7		1	30	2	1
12	14	13		1	29	2	1
13	14	12		1	29	2	1
14	11	12		1	32	2	1
15	10	11		1	32	2	1
16	9	10		1	32	2	1
17	15	28		1	28	2	1
18	16	17		1	30	2	1
19	28	17		1	29	2	1
20	17	18		1	30	2	1
21	18	19		1	31	2	1
22	19	20		1	31	2	1
23	20	21		1	31	2	1
24	21	22		1	31	2	1
25	22	27		1	32	2	1
26	26	27		1	32	2	1
27	17	21		1	30	2	1
28	28	27		1	29	2	1
29	28	26		1	29	2	1
30	25	26		1	32	2	1
31	24	25		1	32	2	1
32	23	24		1	32	2	1
33	5	19		1	32	2	1
34	12	26		1	31	2	1
35	9	23		1	32	2	1
36	10	24		1	32	2	1
37	8	10	12			1	1
38	22	24	26			1	1
12	26	5	19				
10	24	9	23				

1111101
2111101
15111101
16111101

Figure 23 (contd). Input data listing case no. 2.

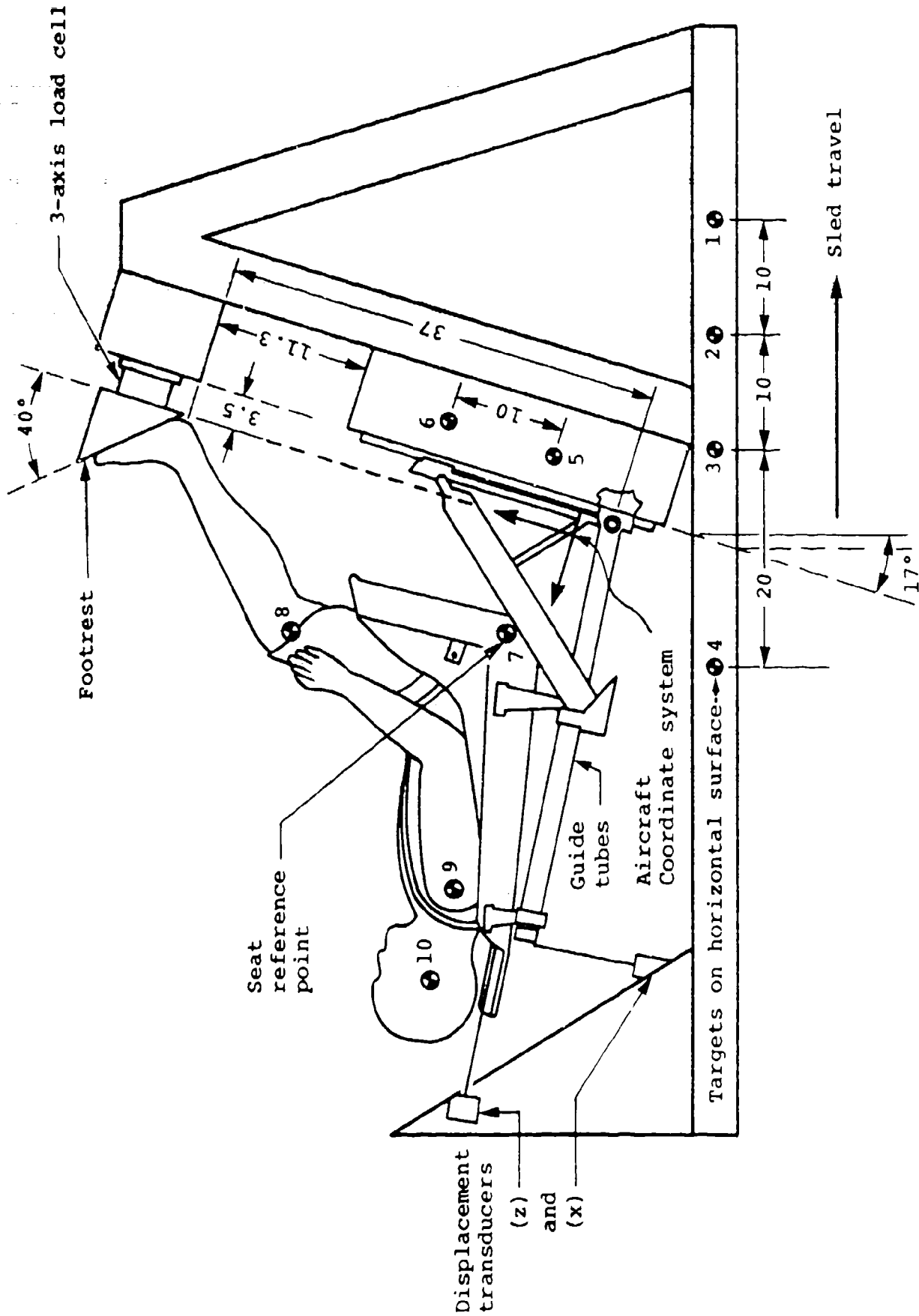

Figure 24. Configuration for dynamic test of energy-absorbing helicopter seat.

CAMI TEST AB1-114 (PART 572 DUMMY)

	1	2	1	1	3	0	0	8	1	0	2
	0.	.020	.040	.060	.080	.100	.120	.140	0.0010		
	0.	0.	0.	0.	0.	0.	0.	0.			
	240.	.0010	.0010	.1	.001	0.	.250	.0010			
	760.	0.50	2.40	2.5							
	760.	0.50	2.40	1.5							
4	1	1	1	1							
	1000.	.216	2.40	1.0							
	1620.	5000.	10000.	.0080	.0520	.0900	0.00	0.			
	3.6	-9.	13.1	3.6	9.	13.1	33.0	40.			
	910.	2500.	5000.	.0080	.0520	.0900	0.00	0.			
	-6.02	0.	36.2	12.	5.						
	1000.	1570.	5000.	.0133	.0467	.1112	0.00	0.			
	13.16	0.	10.2								
	0.	-0.841	-1.68	-3.22	-4.32	-7.33	-8.32	-9.25			
	-10.23	-11.72	-12.13	-11.65	-10.25	0.38	0.77	0.			
	0.	.0055	.0085	.0130	.0175	.0250	.0280	.0315			
	.0382	.0440	.0480	.0515	.0535	.0590	.0628	.0680			
	0.	2.75	5.50	10.53	14.15	23.97	27.23	30.25			
	33.48	38.35	39.68	38.11	33.52	-1.26	-2.52	0.			
	0.	.0055	.0085	.0130	.0175	.0250	.0280	.0315			
	.0382	.0440	.0480	.0515	.0535	.0590	.0628	.0680			
	12.72	0.	-41.60								
	0.	0.	0.	0.	-73.	0.					
3		.30	.35								
	164.	69.	-13.	-13.	-3.	-13.	58.	33.0			
	10.85	8.35	11.3	13.3	16.5	18.0					
	4.67	6.550	6.330	4.720	6.260	8.350	10.96				
	34.60	35.97	10.10	4.85	4.85	21.70	9.49	1.98			
	2.32	2.18	.275	.132	.017	.127	.927				
	0.76	0.93	.266	.135	.185	1.22	.994	.0177			
	2.32	1.70	.233	.022	.195	.873	.505				
	4.50	4.50	3.44	1.85	1.85	3.10	2.30	2.30			
	1.60	3.56	2.61	1.85	2.34						

Figure 25. Listing of input data.

3.70	6.34	0.20	0.20	2.00			
2000.	.050	2000.	.380				
6000.	.238	1.00	3240.	.270	1.0		
375.0	1.49	150.	375.0	1.49	30.0		
0.	7.5	3.	13.	16.	18.	40.5	18.
2585.	2585.	2585.	0.6	16.	20.	4.	60.6
4308.	0.55	148.	3470000.	2000.			
15510.	156350.	215160.	.0156	.0562	.0885		

Figure 25 (contd). Listing of input data.

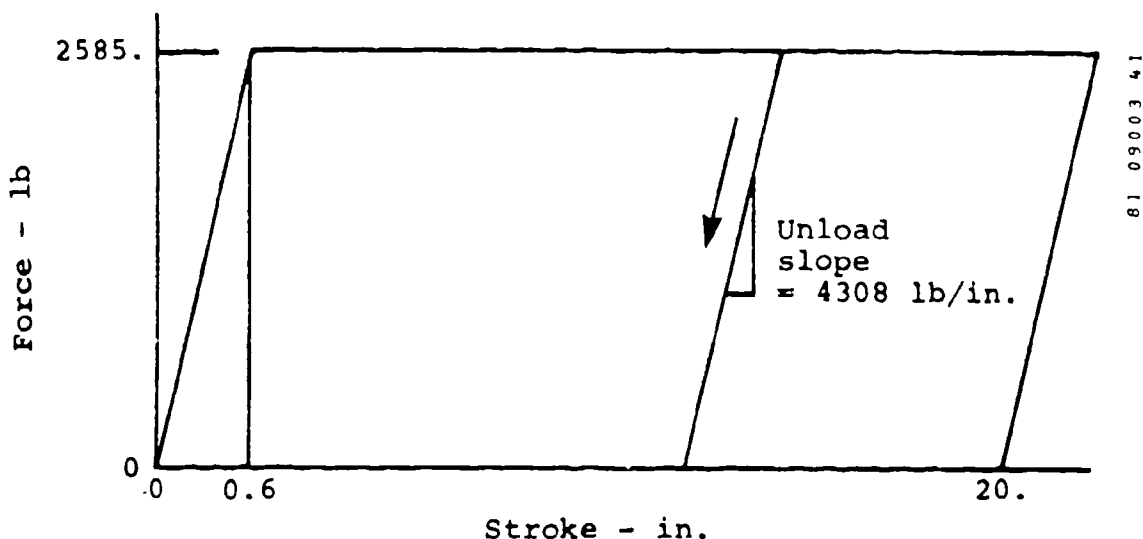

Figure 26. Energy absorber load-stroke characteristics.

such impact occurs. Immediately following line 3, eleven additional lines of data must be provided. The first line contains a single integer which specifies the general type of configuration, zero for a passenger seat or 1 for a cockpit seat.

Using the example of figure 27, a cockpit configuration is desired, where the seat is surrounded by surfaces that represent an instrument panel, a windscreen, etc. The coordinates of the lines of intersection for the cockpit surfaces are given in figure 27 in inches. The eleven additional lines of data for this example are shown in figure 28.

6.0 REFERENCES

1. Chandler, R. F. and Laananen, D. H., "Seat/Occupant Crash Dynamic Analysis Validation Test Program," Paper No. 790590, presented at Business Aircraft Meeting, Wichita, Kansas, Society of Automotive Engineers, Inc., April 1979.
2. "DISSPLA (Display Integrated Software System and Plotting Language): User's Manual," Version 8.2, Integrated Software Systems Corporation, 4186 Sorrento Valley Blvd., San Diego, California 92121, December 1978.

APPENDIX A

PROGRAM SOM-LA INPUT DATA REQUIREMENTS

In this Appendix is presented a line-by-line description of input data required by Program SOM-LA. As described in chapter 2, there are a number of optional lines of data, each of which is suffixed by an alphabetic character, such as line 6A, which is used only if the seat includes a headrest.

LINE 1: Case Identification

DESCRIPTION: Title and type of case.

FORMAT AND EXAMPLE:

1	2	3	4	5	6	7	8		
1234567890	1234567890	1234567890	1234567890	1234567890	1234567890	1234567890	1234567890		
NAME						NUNIT	NSEAT	NDIM	
CAMI SERIES 2 - HIGH DECELERATION						1	1	2	

<u>FIELD</u>	<u>FORMAT</u>	<u>CONTENTS</u>
NAME	6A10	Alphanumeric title of case to be centered at top of printed output and plots.
NUNIT	I5	System of units NUNIT = 0 : SI units NUNIT = 1 : English units.
NSEAT	I5	Seat model NSEAT = 0 : Rigid seat model NSEAT = 1 : Finite element seat model.
NDIM	I5	Definition of occupant degrees of freedom NDIM = 2 : Two-dimensional simulation NDIM = 3 or 0 : Three-dimensional simulation.

LINE 2: Output Selection

DESCRIPTION: Definition of output data to be stored for printing and number of plots.

FORMAT AND EXAMPLE:

1		2		3		4		5		6		7		8	
NOPLT	NSPLOT	DTPLT	TSEAT	IOUT(1)	IOUT(2)	IOUT(3)	IOUT(4)	IOUT(5)	IOUT(6)	IOUT(7)	IOUT(8)	IOUT(9)	IOUT(10)	NOPLT	NSPLOT
1	1	2	0	1	1	2	1	1	1	1	1	1	1	8	8

<u>FIELD</u>	<u>FORMAT</u>	<u>CONTENTS</u>
IOUT	I0I5	<p>Vector of 0's, 1's, 2's and 3's indicating which output data are to be printed (1, 2, or 3) or not printed (0)</p> <p>IOUT(1) : Occupant segment position IOUT(2) : Occupant segment velocity IOUT(3) : Occupant segment acceleration (1) IOUT(4) : Secondary impact prediction (2) IOUT(5) : Restraint system forces IOUT(6) : Injury criteria IOUT(7) : Seat external loads (cushions, floor) (1) IOUT(8) : Seat structure deflections (3) IOUT(9) : Seat structure support reactions IOUT(10) : Stresses in seat structure beam elements (4).</p>
NOPLT	I5	Number of requested occupant position plots (up to 8). Lines 2A and 2B must be inserted if NOPLT > 0.
NSPLOT	I5	Number of requested seat position plots (up to 8). Lines 2A, 2C, and 2D must be inserted if NSPLOT > 0.
DTPLT	F5.0	Interval at which data are written on external file 26, as described in chapter 3. If left blank, 0.001 sec is assumed.
TSEAT	F5.0	Print frequency (in seconds) for data selected with IOUT(8), IOUT(9), and IOUT(10).

<u>FIELD</u>	<u>FORMAT</u>	<u>CONTENTS</u>
CKPTIN	F5.0	: Checkpoint time interval = 0; no operation = 0; make checkpoint every "CKPTIN" seconds = 0; restart and make checkpoints every "-CKPTIN" seconds.
ICPFL	I5	: Restart checkpoint file number.

- (1) For IOUT(3) and IOUT(7), an input value of 1 results in unfiltered output. A value of 2 or 3 results in application of a class 180 (300 Hz) or class 60 (100 Hz) filter, respectively.
- (2) If IOUT(4) = 1, lines 3A - 3K must be included to define aircraft interior surfaces.
- (3) If IOUT(8) = 1, line 2E must be included to select the nodes for seat structure deflections.
- (4) If IOUT(10) = 1, line 2F must be included to select the beam elements for seat structure stresses.

LINE 2A: Plot Times (only if NOPLOT > 0 or NSPLOT > 0)

DESCRIPTION: Times when plots of occupant or seat position are desired. The first NOPLOT fields are read, as defined on line 2.

Occupant and seat plot data are stored on external file numbers 14 and 20, respectively. Therefore, if plots are requested, the job control language must define files 14 and/or 20 as permanent files to be saved. These permanent files can then be used as input to the plotting programs listed in Appendices E and F.

FORMAT AND EXAMPLE:

0	1	2	3	4	5	6	7	8
1234567890	1234567890	1234567890	1234567890	1234567890	1234567890	1234567890	1234567890	1234567890
TPL0T(0)	TPL0T(1)	TPL0T(2)	TPL0T(3)	TPL0T(4)	TPL0T(5)	TPL0T(6)	TPL0T(7)	TPL0T(8)
0.	0.040	0.080	0.120	0.160	0.200	0.240	0.280	

<u>FIELD</u>	<u>FORMAT</u>	<u>CONTENTS</u>
TPL0T	8F10.0	Plot times, seconds.

LINE 2B: Occupant Plot Viewing Angles (only if NOPLOT > 0)

DESCRIPTION: Angles in degrees corresponding to TPLOT times on line 2A. The first NOPLOT fields are read, as on line 2A. The angle is measured in the horizontal plane, as illustrated in figure A-1. An angle of 0 degrees results in a right-side view; 90 degrees, a front view; and 180 degrees, a left-side view.

FORMAT AND EXAMPLE:

0	1	2	3	4	5	6	7	8
1234567890	1234567890	1234567890	1234567890	1234567890	1234567890	1234567890	1234567890	1234567890
ANGVU(1)	ANGVU(2)	ANGVU(3)	ANGVU(4)	ANGVU(5)	ANGVU(6)	ANGVU(7)	ANGVU(8)	ANGVU(9)
0.	0.	0.	0.	0.	0.	0.	0.	0.

<u>FIELD</u>	<u>FORMAT</u>	<u>CONTENTS</u>
ANGVU	8F10.0	NOPLOT occupant viewing angles, degrees.

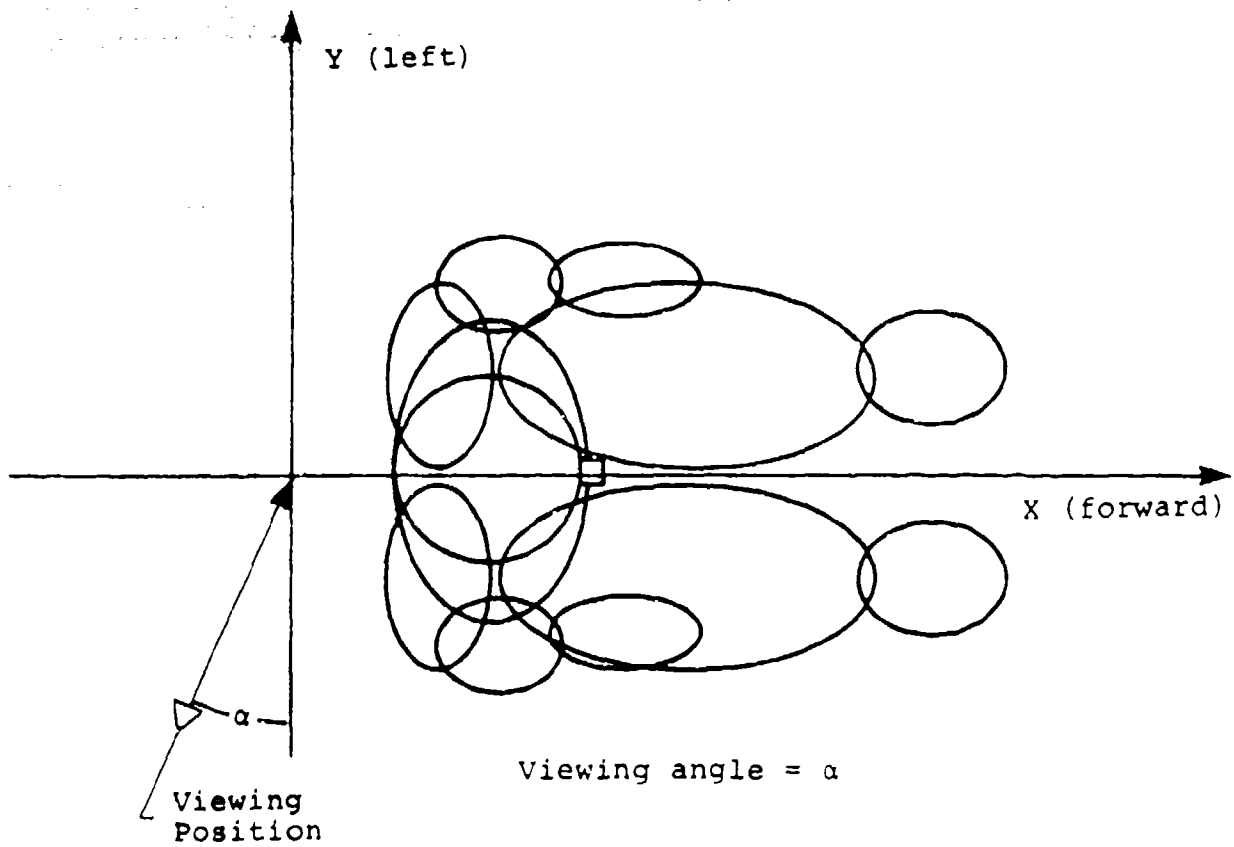

80 04001 38

Figure A-1. Definition of plot viewing angle.

LINE 2C: Seat Structure Plot Viewing Elevation Angle (only if NSPLOT > 0)

DESCRIPTION: Viewing angle ϕ , as defined in figure A-2.

FORMAT AND EXAMPLE:

0	1	2	3	4	5	6	7	8
1234567890	1234567890	1234567890	1234567890	1234567890	1234567890	1234567890	1234567890	1234567890
PHI(1)	PHI(2)	PHI(3)	PHI(4)	PHI(5)	PHI(6)	PHI(7)	PHI(8)	PHI(9)
20.0	20.0	20.0	20.0	20.0	20.0	20.0	20.0	20.0

<u>FIELD</u>	<u>FORMAT</u>	<u>CONTENTS</u>
PHI	8F10.0	NSPLOT elevation angles, degrees.

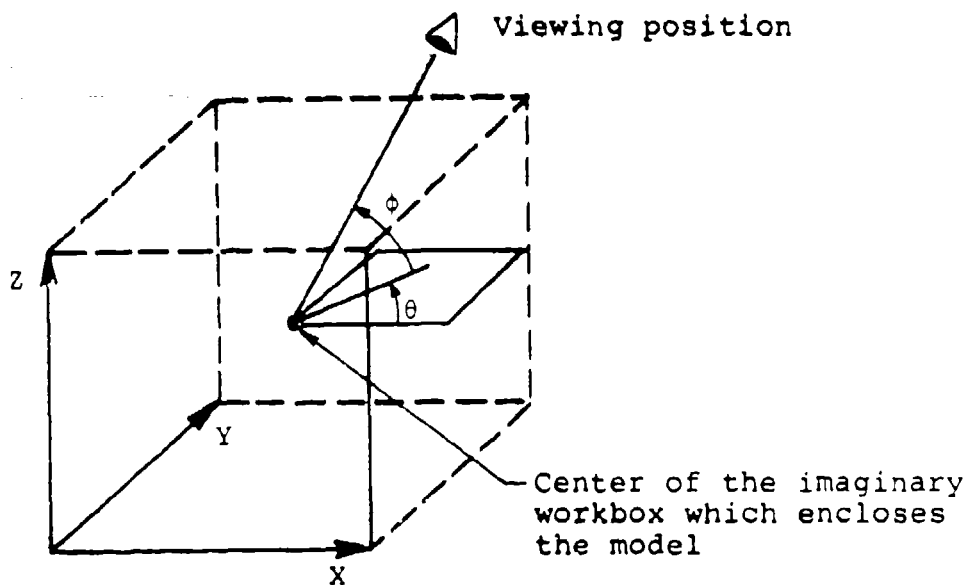

θ = Azimuth angle in X-Y plane in degrees ($-180^\circ \leq \theta \leq +180^\circ$)
 ϕ = Elevation angle in degrees ($-90^\circ \leq \phi \leq +90^\circ$)

Figure A-2. Angular coordinates for viewing position of graphic display models.

LINE 2D: Seat Structure Plot Viewing Azimuth Angle (only if NSPLOT > 0)

DESCRIPTION: Viewing angle θ , as defined in figure A-2.

FORMAT AND EXAMPLE:

0	1	2	3	4	5	6	7	8
1234567890	1234567890	1234567890	1234567890	1234567890	1234567890	1234567890	1234567890	1234567890
THE(1)	THE(2)	THE(3)	THE(4)	THE(5)	THE(6)	THE(7)	THE(8)	THE(9)
45.0	45.0	45.0	45.0	45.0	45.0	45.0	45.0	45.0

<u>FIELD</u>	<u>FORMAT</u>	<u>CONTENTS</u>
THE	8F10.0	Vector of NSPLOT azimuth angles, degrees.

LINE 2E: Nodal Output Selection (only if IOUT(8) ≠ 0)

DESCRIPTION: Node numbers, in pairs, to specify which X, Y, Z displacements are to be printed. (The node numbers are defined on line 47.)

FORMAT AND EXAMPLE:

0	1	2	3	4	5	6	7	8
1234567890	1234567890	1234567890	1234567890	1234567890	1234567890	1234567890	1234567890	1234567890
KNODE(1)	KNODE(2)	KNODE(3)	KNODE(4)	KNODE(5)	KNODE(6)	KNODE(7)	KNODE(8)	KNODE(9)
1	15							

<u>FIELD</u>	<u>FORMAT</u>	<u>CONTENTS</u>
KNODE	5(2I5)	Nodal displacements printed for nodes beginning with KNODE(I) through KNODE(I+1), inclusive. Up to 5 pairs of nodes are permitted.

LINE 2F: Beam Stress Selection (only if IOUT(10) ≠ 0)

DESCRIPTION: Element numbers, in pairs, to specify which stresses are to be printed. Maximum and minimum values of stress are printed at both ends of selected beams.

FORMAT AND EXAMPLE:

1		2		3		4		5		6		7		8	
1234567890	1234567890	1234567890	1234567890	1234567890	1234567890	1234567890	1234567890	1234567890	1234567890	1234567890	1234567890	1234567890	1234567890	1234567890	1234567890
KBEAM(1)	KBEAM(2)	KBEAM(3)	KBEAM(4)	KBEAM(5)	KBEAM(6)	KBEAM(7)	KBEAM(8)	KBEAM(9)	KBEAM(10)						
1	6														

<u>FIELD</u>	<u>FORMAT</u>	<u>CONTENTS</u>
KBEAM	5(2I5)	Stresses printed for beam elements beginning with KBEAM(I) through KBEAM(I+1) inclusive. Up to 5 pairs of elements are permitted.

LINE 3: Simulation Control Data

DESCRIPTION: Parameters for control of solution duration, step size, and error bounds.

FORMAT AND EXAMPLE:

0	1	2	3	4	5	6	7	8
1234567890	1234567890	1234567890	1234567890	1234567890	1234567890	1234567890	1234567890	1234567890
TMAX	DMAX	DMIN	EUR	ELR	T1	T2	DT	
900.	0.0005	0.0005	0.10	0.001	0.	0.300	0.0005	

<u>FIELD</u>	<u>FORMAT</u>	<u>CONTENTS</u>
TMAX	F10.0	The maximum time allotted for the run on the job card in decimal seconds. This will ensure that the solution is terminated in time to permit printing of the output already computed.
DMAX	F10.0	Maximum step size. A value of 0.001 sec has been used successfully.
DMIN	F10.0	Minimum step size. A value as large as 0.001 sec has been used successfully, but the use of very stiff restraint system webbing or seat cushions may require a smaller value, such as 0.00001. The solution can be accomplished with a fixed step size by setting DMIN = DMAX.
EUR	F10.0	Maximum bound on error between predictor and corrector. A value of 0.05 to 0.10 is suggested, corresponding to a range of 5 to 10 percent. If the error in any variable is larger than this value, the step size is halved, maintaining solution accuracy.
ELR	F10.0	Lower bound on error between predictor and corrector. A value of 0.001 is suggested, corresponding to 0.1 percent. If the error in all variables is smaller than this value, the step size is doubled, preventing the computer execution cost from becoming excessively high.

FIELDFORMATCONTENTS

Note: Because doubling the step size multiplies the truncation error in the Adams-Moulton integrator by a factor of 2^5 , ELR should be chosen less than EUR/32 if the advantages of doubling are not to be short-lived.

TI	F10.0	Initial solution time in seconds. Normally taken as 0, unless restarting the solution.
TF	F10.0	Final solution time in seconds.
DTI	F10.0	Initial step size, normally set equal to DMIN.

LINE 3A: Cockpit Configuration Identification (only if IOUT(4) = 1)

DESCRIPTION: An integer that specifies either of the types of configuration shown in figure A-3.

FORMAT AND EXAMPLE:

0	1	2	3	4	5	6	7	8
1234567890	1234567890	1234567890	1234567890	1234567890	1234567890	1234567890	1234567890	1234567890
ICKPT								

<u>FIELD</u>	<u>FORMAT</u>	<u>CONTENTS</u>
ICKPT	I5	Identification of cockpit configuration.

*Line not present for sample case.

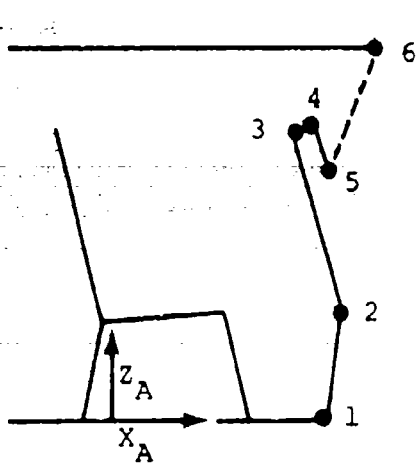

Passenger seat
(ICKPT = 0)

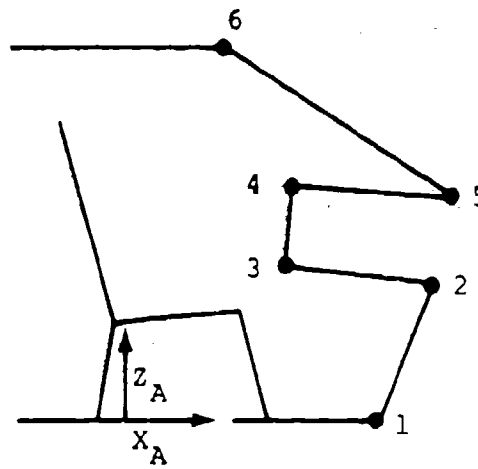

Crewseat
(ICKPT = 1)

30 04001 39

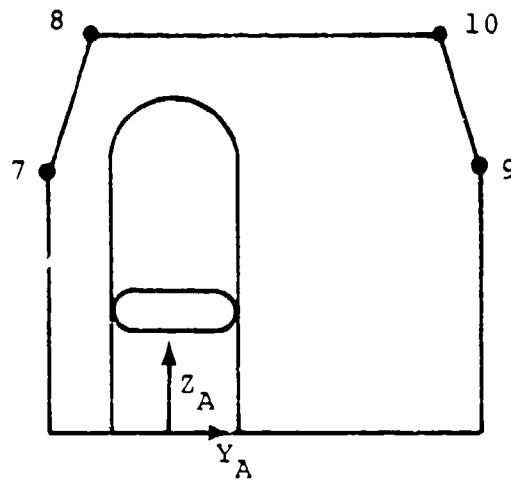

Figure A-3. Cockpit geometry definition for secondary impact prediction.

LINE 3B - 3K: Cockpit Coordinates (only if IOUT(4) = 1)

DESCRIPTION: Coordinates of points that define cockpit geometry.

FORMAT AND EXAMPLE:

0	1	2	3	4	5	6	7	8
123 456789	1234567890	1234567890	1234567890	1234567890	1234567890	1234567890	1234567890	1234567890
DEADB	VSABLD	DEADB						

<u>FIELD</u>	<u>FORMAT</u>	<u>CONTENTS</u>
XCAS(J)	3F10.0	These lines contain coordinates of ten points that define cockpit geometry. X and Z coordinates are required for the 6 points shown in figure A-3; Y and Z coordinates for points 7-10 that define the sides of the aircraft.
YCAS(J)		
ZCAS(J)		
J = 1,10		

*Line not present in sample case.

LINE 4: Combined Seat Cushion and Occupant Buttocks Properties

DESCRIPTION: Force-deflection characteristics and damping for seat cushion and buttocks combined; thickness for seat bottom cushion. The force, F, is computed from total deflection, δ , according to $F = C(e^{B\delta} - 1)$.

FORMAT AND EXAMPLE:

0	1	2	3	4	5	6	7	8
1234567890	1234567890	1234567890	1234567890	1234567890	1234567890	1234567890	1234567890	1234567890
CSC	BSC	DPSC	THSCE					
375.	.653	.85	3.00					

<u>FIELD</u>	<u>FORMAT</u>	<u>CONTENTS</u>
CSC	F10.0	Coefficient C in above equation (lb).
BSC	F10.0	Coefficient B in above equation (in. ⁻¹).
DPSC	F10.0	Damping coefficient at zero load (lb-sec/in.).
THSCE	F10.0	Unloaded thickness of cushion under buttocks (in.) This 3.0 in. dimension includes the thickness of the beam element surrounding the seat pan for this example.

LINE 5: Back Cushion Properties

DESCRIPTION: Force-deflection characteristics, damping, and thickness for back cushion. These characteristics should be measured using an indenter with the form of the occupant torso. If a dummy torso is used in measurement, the deflection should be based on the chest accelerometer location. The force, F , is computed from cushion deflection, δ , according to $F = C(e^{B\delta} - 1)$.

FORMAT AND EXAMPLE:

1	2	3	4	5	6	7	8
1234567890	1234567890	1234567890	1234567890	1234567890	1234567890	1234567890	1234567890
CBC	BBC	DPBC	THBCE				
375.	0.653	.85	3.00				

<u>FIELD</u>	<u>FORMAT</u>	<u>CONTENTS</u>
CBC	F10.0	Coefficient C in above equation (lb).
BBC	F10.0	Coefficient B in above equation (in. ⁻¹).
DPBC	F10.0	Damping coefficient at zero load (lb-sec/in.).
THBCE	F10.0	Unloaded thickness of cushion in center of seat back (in.), including thickness of beams for this example.

LINE 6: Restraint System Identification

DESCRIPTION: Integers defining configuration of restraint system and presence or absence of headrest.

FORMAT AND EXAMPLE:

0	1	2	3	4	5	6	7	8
1234567890	1234567890	1234567890	1234567890	1234567890	1234567890	1234567890	1234567890	1234567890
IRSYS	IBUCL	ILPBLT	ISHRNS	IHRST				
5	1	1	1	0				

<u>FIELD</u>	<u>FORMAT</u>	<u>CONTENTS</u>
IRSYS	I5	Restraint system configuration. IRSYS = 0 : Lap belt only IRSYS = 1 : Diagonal shoulder belt over right shoulder IRSYS = 2 : Diagonal shoulder belt over left shoulder IRSYS = 3 : Double shoulder belt IRSYS = 4 : Double shoulder belt and lap belt tiedown strap - requires lines 10A and 10B.
IBUCL	I5	Buckle connection type (see figure A-4).
ILPBLT	I5	Lap belt attachment ILPBLT = 0 : Attached to airframe ILPBLT = 1 : Attached to seat.
ISHRNS	I5	Shoulder harness attachment ISHRNS = 0 : Attached to airframe ISHRNS = 1 : Attached to seat.
IHRST	I5	Headrest option IHRST = 0 : No headrest IHRST = 1 : Headrest included - requires line 6A.

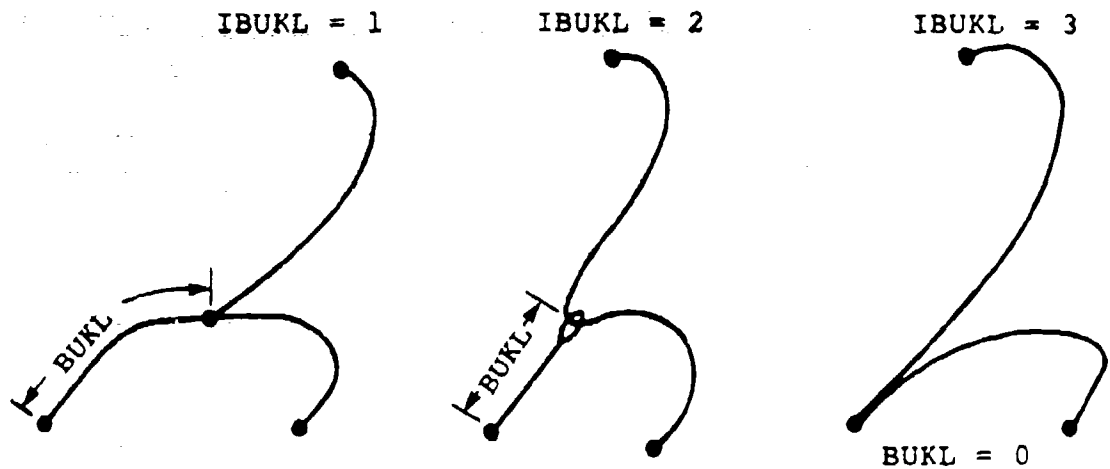

- 1 = Shoulder belt fixed to buckle
- 2 = Shoulder belt and one side of lap belt are one length of webbing
- 3 = Shoulder belt and lap belt attached to fixed point

NOTE: BUKL parameter is defined on line 10.

Figure A-4. Types of buckle connections specified by IBUKL on line 6.

LINE 6A: Headrest Cushion Properties (only if IHRST = 1)

DESCRIPTION: Force-deflection characteristics, damping, and thickness for seat bottom cushion. The measurement should be made using a headform. The force, F, is computed from cushion deflection, δ , according to $F = C(e^{B\delta} - 1)$.

FORMAT AND EXAMPLE:

1	2	3	4	5	6	7	8
1234567890	1234567890	1234567890	1234567890	1234567890	1234567890	1234567890	1234567890
CHR	BHR	DPHR	THHRE				

<u>FIELD</u>	<u>FORMAT</u>	<u>CONTENTS</u>
CHR	F10.0	Coefficient C in above equation (lb).
BHR	F10.0	Coefficient B in above equation (in. ⁻¹).
DPHR	F10.0	Damping coefficient (lb-sec/in.).
THHRE	F10.0	Unloaded thickness of cushion behind head (in.).

*Line not present for sample case.

LINE 7: Lap Belt Properties

DESCRIPTION: Tables of forces and deflections define an approximation to force-deflection curve by three linear segments, as illustrated in figure A-5. The force and deflection at point 1 are assumed to be zero.

FORMAT AND EXAMPLE:

0	1	2	3	4	5	6	7	8
1234567890	1234567890	1234567890	1234567890	1234567890	1234567890	1234567890	1234567890	1234567890
FFLB(1)	FFLB(2)	FFLB(3)	DDLB(1)	DDLB(2)	DDLB(3)	DPLB	SLAB	
550.	1300.	2250.	0.0403	0.1048	0.1613	0.	0.	0.

<u>FIELD</u>	<u>FORMAT</u>	<u>CONTENTS</u>
FFLB	3F10.0	Forces (lb).
DDLB	3F10.0	Strains corresponding to forces (in./in.).
DPLB	F10.0	Damping coefficient (lb-sec).
SLAB	F10.0	Slack in the total lap belt loop, the length that, if removed, would cause the belt to pass snugly over the occupant with zero load (in.).

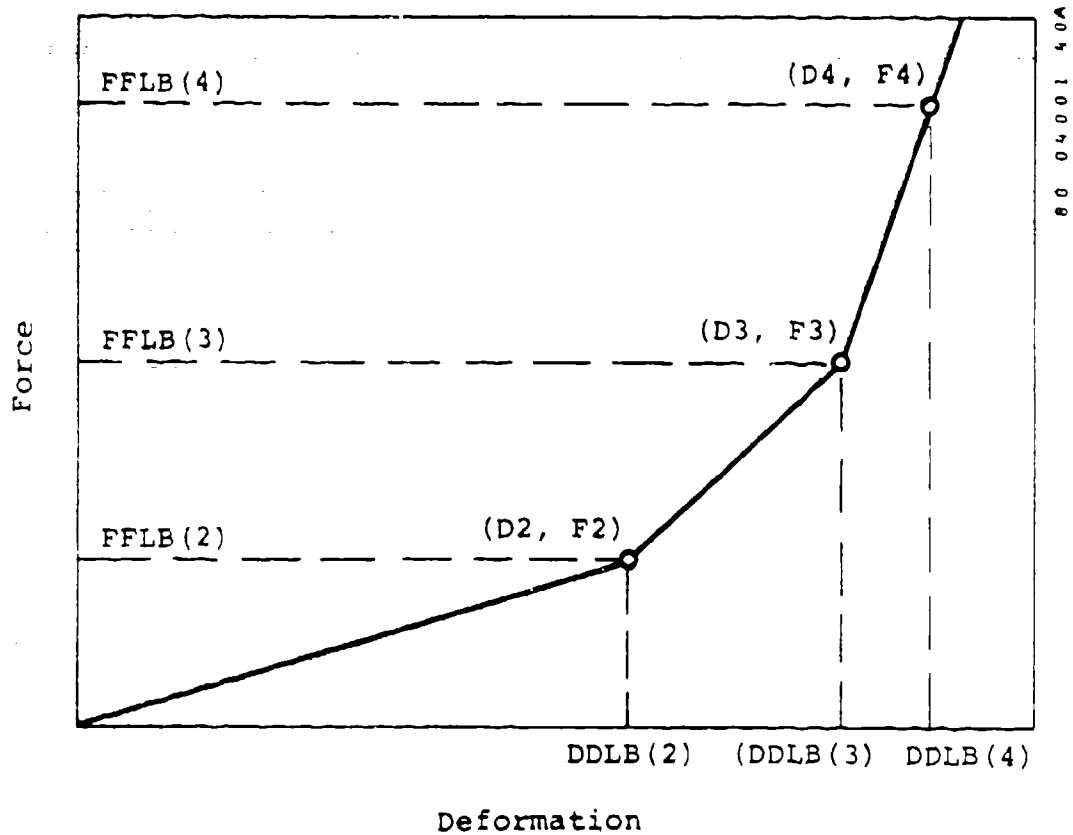

Figure A-5. Force-deflection model for restraint system webbing.

LINE 8: Lap Belt Anchor Points and Footrest

DESCRIPTION: Coordinates of right and left lap belt anchor points in aircraft coordinate system; location of footrest.

FORMAT AND EXAMPLE:

0	1	2	3	4	5	6	7	8
1234567890	1234567890	1234567890	1234567890	1234567890	1234567890	1234567890	1234567890	1234567890
XLB(1)	YLB(1)	ZLB(1)	XLB(2)	YLB(2)	ZLB(2)	XFR	ANGFR	
0.75	-9.	13.6	0.75	9.	13.6	28.	0.	

<u>FIELD</u>	<u>FORMAT</u>	<u>CONTENTS</u>
XLB(1) YLB(1) ZLB(1)	3F10.0	Coordinates of right-hand lap belt anchor point in aircraft coordinate system (in.).
XLB(2) YLB(2) ZLB(2)	3F10.0	Coordinates of left-hand lap belt anchor point in aircraft coordinate system (in.).
XFR	F10.0	X-coordinate of footrest in aircraft coordinate system, at intersection with floor, where Z = 0 (in.). If no footrest, leave blank.
ANGFR	F10.0	Angle between footrest and floor (degrees).

LINE 9: Shoulder Belt Properties

DESCRIPTION: Tables of forces and deflections define an approximation to force-deflection curve by three linear segments, as illustrated in figure A-5. The force and deflection at point 1 are assumed to be zero.

FORMAT AND EXAMPLE:

0	1	2	3	4	5	6	7	8
1234567890	1234567890	1234567890	1234567890	1234567890	1234567890	1234567890	1234567890	1234567890
FFSH(2)	FFSH(3)	FFSH(4)	DDSH(2)	DDSH(3)	DDSH(4)	DPSH	SLSH	
550.	1300.	2250.	0.0403	0.1048	0.1613	0.	0.	

<u>FIELD</u>	<u>FORMAT</u>	<u>CONTENTS</u>
FFSH	3F10.0	Forces (lb).
DDSH	3F10.0	Strain corresponding to forces (in./in.).
DPSH	F10.0	Damping coefficient (lb-sec).
SLSH	F10.0	Shoulder belt slack (in.).

LINE 10: Shoulder Belt Anchor Points

DESCRIPTION: Coordinates of shoulder belt anchor point in aircraft coordinate system, along with other restraint system characteristics.

FORMAT AND EXAMPLE:

0	1	2	3	4	5	6	7	8
1234567890	1234567890	1234567890	1234567890	1234567890	1234567890	1234567890	1234567890	1234567890
XSH	YSH	ZSH	BUKL	XTRAL				
0.	0.	21.38	12.	0.				

<u>FIELD</u>	<u>FORMAT</u>	<u>CONTENTS</u>
XSH YSH ZSH	3F10.0	Coordinates of shoulder belt anchor point in aircraft coordinate system, or point from which belt passes to shoulder in a straight line.
BUKL	F10.0	Length of lap belt webbing attached to buckle, illustrated in figure A-4 (in.).
XTRAL	F10.0	Length of shoulder strap beyond (XSH, YSH, ZSH) if strap not in straight line, as shown in figure A-6 (in.).

(XSH, YSH, ZSH)

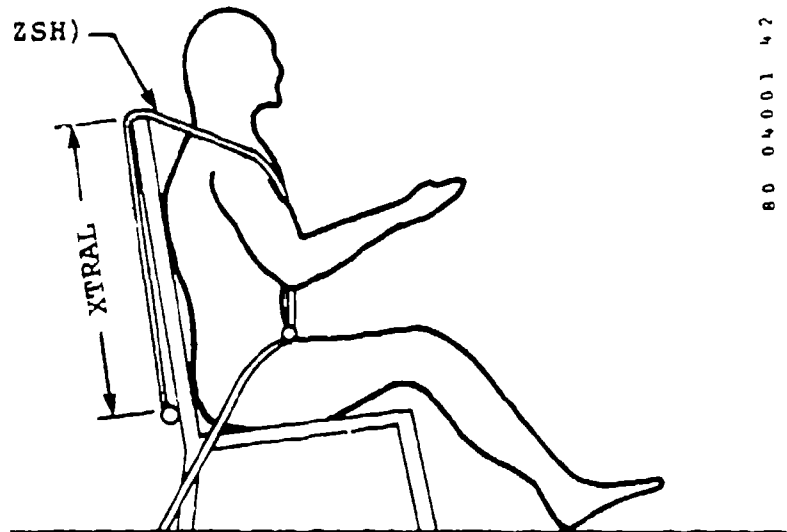

80 04001 42

Figure A-6. XTRAL dimensions for shoulder belts on line 10.

LINE 10A: Tiedown Strap Properties (only if IRSYS = 4)

DESCRIPTION: For lap belt tiedown strap (negative-G strap) tables of forces and deflections define an approximation of force-deflection curve by three linear segments, as illustrated in figure A-5. The force and deflection at point 1 are assumed to be zero.

FORMAT AND EXAMPLE:

1	2	3	4	5	6	7	8
1234567890	1234567890	1234567890	1234567890	1234567890	1234567890	1234567890	1234567890
F10.0	F10.0	F10.0	D10.0	D10.0	D10.0	D10.0	SLTD

<u>FIELD</u>	<u>FORMAT</u>	<u>CONTENTS</u>
F10.0	F10.0	Forces (lb).
D10.0	D10.0	Strains corresponding to forces (in./in.).
D10.0	F10.0	Damping coefficient (lb-sec).
SLTD	F10.0	Tiedown strap slack (in.).

*Line not present for sample case.

LINE 10B: Tiedown Strap Anchor Point (only if IRSYS = 4)

DESCRIPTION: Coordinates of tiedown (negative-G) strap in aircraft coordinate system.

FORMAT AND EXAMPLE:

0	1	2	3	4	5	6	7	8
1234567890	1234567890	1234567890	1234567890	1234567890	1234567890	1234567890	1234567890	1234567890
XTD	YTD	ZTD						

<u>FIELD</u>	<u>FORMAT</u>	<u>CONTENTS</u>
XTD	3F10.0	Coordinates of tiedown strap anchor point in aircraft coordinate system (in.).
YTD		
ZTD		

*Line not present for sample case.

LINE 11 - 34: Aircraft Acceleration

DESCRIPTION: The time variation of each of the six components of the acceleration of the aircraft coordinate system is approximated by up to 16 points in acceleration and time.

FORMAT AND EXAMPLE: (Lines 11 - 14)

0	1	2	3	4	5	6	7	8
1234607000	1234607000	1234607000	1234607000	1234607000	1234607000	1234607000	1234607000	1234607000
AX(1)	AX(2)	AX(3)	AX(4)	AX(5)	AX(6)	AX(7)	AX(8)	
0.	-0.16	-4.04	-4.20	-5.91	-5.75	-5.05	-6.14	
AX(9)	AX(10)	AX(11)	AX(12)	AX(13)	AX(14)	AX(15)	AX(16)	
-5.44	-6.22	-5.36	-5.83	-5.44	-5.44	1.32	0.	
TX(1)	TX(2)	TX(3)	TX(4)	TX(5)	TX(6)	TX(7)	TX(8)	
0.	.008	.018	.025	.031	.036	.040	.048	
TX(9)	TX(10)	TX(11)	TX(12)	TX(13)	TX(14)	TX(15)	TX(16)	
.057	.065	.072	.080	.084	.263	.283	.314	

<u>FIELD</u>	<u>FORMAT</u>	<u>CONTENTS</u>
Lines 11 and 12:		
AX(J), J = 1-8	8F10.0	X-acceleration (G).
AX(J), J = 9-16	8F10.0	
Lines 13 and 14:		
TX(J), J = 1-8	8F10.0	X-time corresponding to lines 11 and 12 (sec).
TX(J), J = 9-16	8F10.0	
Lines 15 and 16:		Y-acceleration (G).
Lines 17 and 18:		Y-time (sec).
Lines 19 and 20:		Z-acceleration (G).
Lines 21 and 22:		Z-time (sec).
Lines 23 and 24:		Yaw acceleration (rad/sec/sec).
Lines 25 and 26:		Yaw time (sec).
Lines 27 and 28:		Pitch acceleration (rad/sec/sec).
Lines 29 and 30:		Pitch time (sec).
Lines 31 and 32:		Roll acceleration (rad/sec/sec).
Lines 33 and 34:		Roll time (sec).

LINE 35: Aircraft Initial Velocity

DESCRIPTION: Components of aircraft initial velocity, in aircraft coordinate system, translation and rotation.

FORMAT AND EXAMPLE:

0	1	2	3	4	5	6	7	8
1234567890	1234567890	1234567890	1234567890	1234567890	1234567890	1234567890	1234567890	1234567890
VX	VY	VZ	DYAW	DPITCH	DROLL			
44.18	0.	0.	0.	0.	0.			

<u>FIELD</u>	<u>FORMAT</u>	<u>CONTENTS</u>
VX VY VZ	3F10.0	Components of aircraft initial velocity in aircraft coordinate system (ft/sec).
DYAW DPITCH DROLL	3F10.0	Yaw, pitch, and roll rates (rad/sec).

LINE 36: Aircraft Initial Position

DESCRIPTION: Components of aircraft initial position, in earth-fixed coordinate system, and attitude.

FORMAT AND EXAMPLE:

0	1	2	3	4	5	6	7	8
1234567890	1234567890	1234567890	1234567890	1234567890	1234567890	1234567890	1234567890	1234567890
XA	YA	ZA	YAW	PITCH	ROLL			
0.	0.	0.	0.	0.	0.			

<u>FIELD</u>	<u>FORMAT</u>	<u>CONTENTS</u>
XA YA ZA	3F10.0	Position of aircraft coordinate system in inertial system (earth-fixed system in which gravity acts in the -Z direction) (in.). These initial coordinates are normally taken as (0., 0., 0.) unless displacement from a specific point is desired. For example, if the simulation is to be initiated at some horizontal distance from a barrier, such as 60 in., the initial position could be specified as (-60., 0., 0.). If the simulation is to begin 10 in. above the ground in a vertical drop, the initial position could be specified as (0., 0., 10.). These coordinates are not used in the simulation but only in output of aircraft position.
YAW PITCH ROLL	3F10.0	Initial attitude of aircraft relative to earth-fixed system (deg).

LINE 37: Occupant Identification and Friction Coefficients

DESCRIPTION: Identification of type of occupant (human or dummy).

NOTE: IMAN = 2 or 3 requires addition of lines 38A - 38L.

FORMAT AND EXAMPLE:

0	1	2	3	4	5	6	7	8
1234567890	1234567890	1234567890	1234567890	1234567890	1234567890	1234567890	1234567890	1234567890
IMAN		COEFFS	COEFFR					
3		0.19	0.25					

<u>FIELD</u>	<u>FORMAT</u>	<u>CONTENTS</u>
IMAN	I5	Identification of occupant
	5X	IMAN = 0 : Standard 50th-percentile male human
		IMAN = 1 : Standard 50th-percentile (Part 572) dummy
		IMAN = 2 : Nonstandard human
		IMAN = 3 : Nonstandard dummy.
COEFFS	F10.0	Seat cushion friction coefficient.
COEFFR	F10.0	Floor-foot friction coefficient.

LINE 38: Occupant Initial Position

DESCRIPTION: Weight and stature for nonstandard occupant; initial position angles and heel X-position, as illustrated in figure A-7. The heels are assumed to begin at Z = 0. The torso is aligned according to GAM(1), GAM(2), and GAM(3), and the position is then determined from static equilibrium, allowing for compression of the cushions.

FORMAT AND EXAMPLE:

0	1	2	3	4	5	6	7	8
1234567890	1234567890	1234567890	1234567890	1234567890	1234567890	1234567890	1234567890	1234567890
W	S	GAM(1)	GAM(2)	GAM(3)	GAM(4)	GAM(5)	GAM(6)	XHEEL
164.38	69.1	0.	0.	23.	-17.		60.	26.

<u>FIELD</u>	<u>FORMAT</u>	<u>CONTENTS</u>
W	F10.0	Occupant weight (lb) - used only for nonstandard occupant.
S	F10.0	Occupant stature (in.) - used only for nonstandard occupant.
GAM	5F10.0	Vector of initial position angular coordinates, as illustrated in figure A-7 (deg).
XHEEL	F10.0	X-coordinate of heels in aircraft coordinate system (in.).

Note: If XHEEL is greater than the footrest coordinate, XFR, on line 8, and the footrest angle, ANGFR, is greater than zero, the feet will be moved rearward until they rest on the footrest.

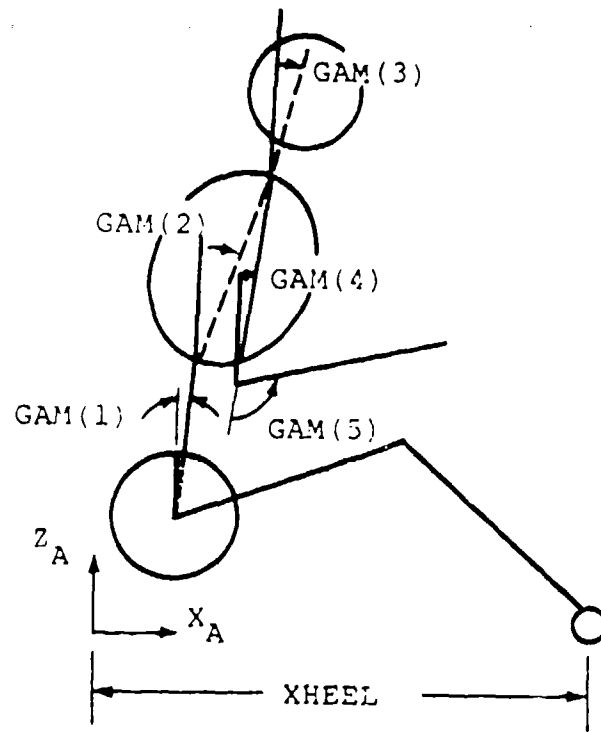

80 04001 43

Figure A-7. Occupant initial position input data.

LINES 38A - 38L: Nonstandard Occupant Input Data

If a nonstandard occupant is requested by setting IMAN = 2 (human) or IMAN = 3 (dummy) on line 37, then 12 additional lines must be inserted following line 37. The format for these 12 lines, referred to as 38A - 38L is explained on the following 15 pages. If IMAN = 1 (standard occupant), skip this section and proceed to line 39.

For this example, even though a 50th-percentile dummy was used in the tests, a nonstandard occupant is requested. Properties of the standard (Part 572) dummy are then input. The results for this example should be the same as if IMAN = 1 on line 37 and lines 38A-38L were omitted.

LINE 38A: Segment Lengths (only if IMAN = 2 or 3)

DESCRIPTION: Lengths of the spine and segments 3, 4, 5, 8, and 9 as described in figure A-8. The lengths of 6, 7, 10, and 11 are obtained from these by symmetry (in.).

FORMAT AND EXAMPLE:

1	2	3	4	5	6	7	8
SPL	XL(3)	XL(4)	XL(5)	XL(8)	XL(9)		
10.85	8.35	11.3	13.3	16.5	18.0		

<u>FIELD</u>	<u>FORMAT</u>	<u>CONTENTS</u>
SPL	F10.0	Spinal length.
XL(3)	F10.0	Head Length.
XL(4)	F10.0	Upper arm length.
XL(5)	F10.0	Lower arm length - elbow to mid-point of hand.
XL(8)	F10.0	Upper leg length.
XL(9)	F10.0	Lower leg length - knee to ankle.

⊕ Center of Mass
 ● Joint
 CIIID Beam-Column Element

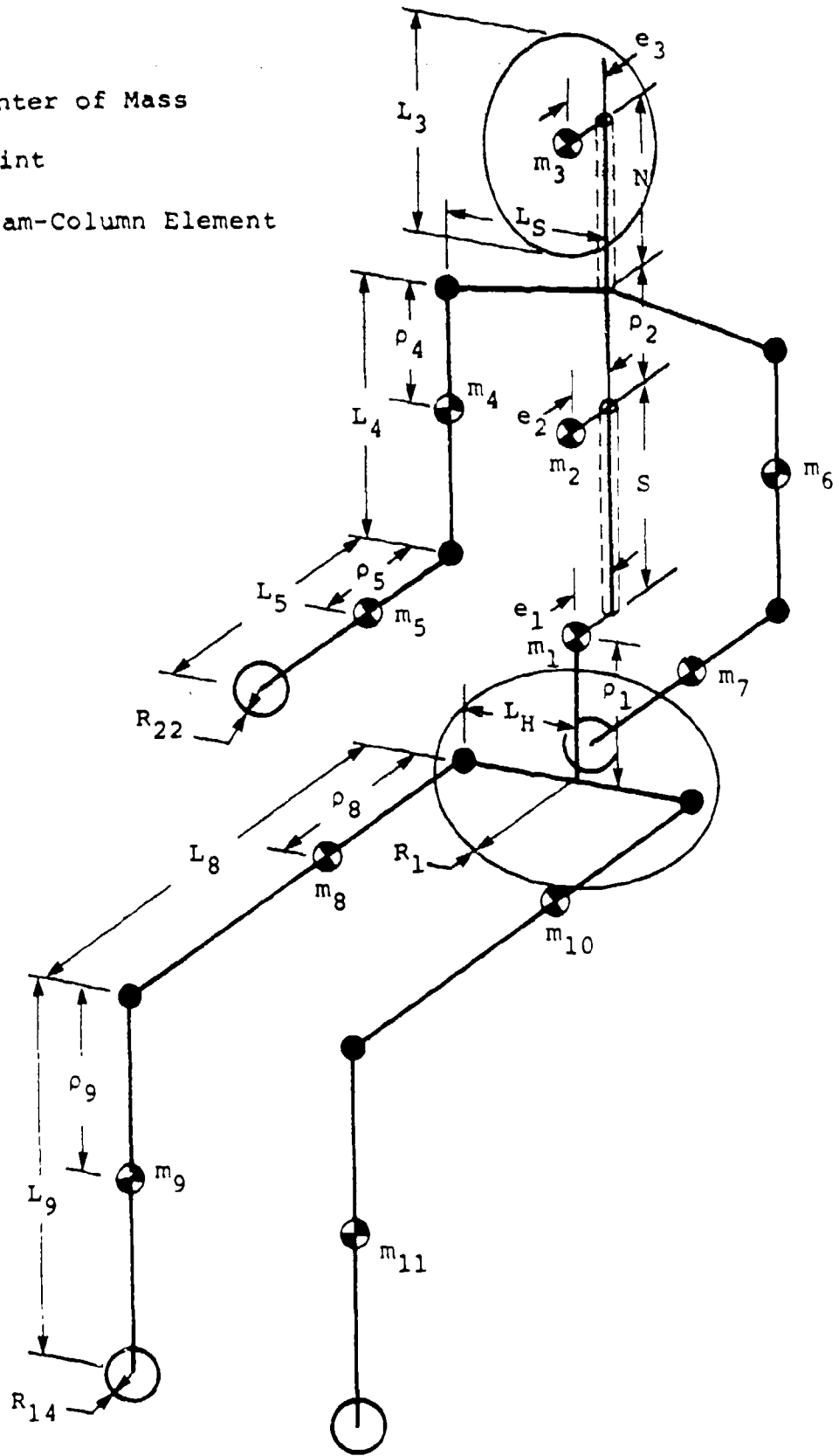

81 07005 01

Figure A-8. Program SOM-LA body segment dimensions.

LINE 38B: Segment Center of Mass Location (only if IMAN = 2 or 3)

DESCRIPTION: Center of mass locations for segments 1, 2, 3, 4, 5, 8, and 9. See figure A-8 for datum plane description (in.).

FORMAT AND EXAMPLE:

0	1	2	3	4	5	6	7	8
1234567890	1234567890	1234567890	1234567890	1234567890	1234567890	1234567890	1234567890	1234567890
RHO(1)	RHO(2)	RHO(3)	RHO(4)	RHO(5)	RHO(6)	RHO(8)	RHO(9)	
4.67	6.55	6.33	4.72	6.26	8.35	10.96		

<u>FIELD</u>	<u>FORMAT</u>	<u>CONTENTS</u>
RHO(1)	F10.0	Lower torso center of mass vertical distance from hip pivot.
RHO(2)	F10.0	Upper torso center of mass distance from base of neck.
RHO(3)	F10.0	Head center of mass distance from base of neck.
RHO(4)	F10.0	Upper arm center of mass distance from shoulder pivot.
RHO(5)	F10.0	Lower arm center of mass distance from elbow pivot.
RHO(8)	F10.0	Upper leg center of mass distance from hip pivot.
RHO(9)	F10.0	Lower leg center of mass distance from knee pivot.

LINE 38C: Segment Weight (only if IMAN = 2 or 3)

DESCRIPTION: Weights of segments 1, 2, 3, 4, 5, 8, 9 and 12 (lb).

FORMAT AND EXAMPLE:

0	1	2	3	4	5	6	7	8
1234567890	1234567890	1234567890	1234567890	1234567890	1234567890	1234567890	1234567890	1234567890
SW(1)	SW(2)	SW(3)	SW(4)	SW(5)	SW(8)	SW(9)	SW(12)	
34.80	35.97	10.10	4.85	4.85	21.70	9.99	1.98	

<u>FIELD</u>	<u>FORMAT</u>	<u>CONTENTS</u>
SW(1)	F10.0	Lower torso weight.
SW(2)	F10.0	Upper torso weight.
SW(3)	F10.0	Head weight.
SW(4)	F10.0	Upper arm weight.
SW(5)	F10.0	Lower arm weight.
SW(8)	F10.0	Upper leg weight.
SW(9)	F10.0	Lower leg weight.
SW(12)	F10.0	Neck weight.

LINE 38D: Segment Moment of Inertia with Respect to Local x-axis
(only if IMAN = 2 or 3)

DESCRIPTION: Moments of inertia with respect to x-axis₂ for segments 1, 2, 3, 4, 5, 8, and 9 (lb-in.-sec²).

FORMAT AND EXAMPLE:

0	1	2	3	4	5	6	7	8
1234567890	1234567890	1234567890	1234567890	1234567890	1234567890	1234567890	1234567890	1234567890
CIX(1)	CIX(2)	CIX(3)	CIX(4)	CIX(5)	CIX(8)	CIX(9)		
2.32	2.18	.275	.132	.017	.127	.927		

<u>FIELD</u>	<u>FORMAT</u>	<u>CONTENTS</u>
CIX(1)	F10.0	Lower torso x-axis moment of inertia.
CIX(2)	F10.0	Upper torso x-axis moment of inertia.
CIX(3)	F10.0	Head x-axis moment of inertia.
CIX(4)	F10.0	Upper arm x-axis moment of inertia.
CIX(5)	F10.0	Lower arm x-axis moment of inertia.
CIX(8)	F10.0	Upper leg x-axis moment of inertia.
CIX(9)	F10.0	Lower leg x-axis moment of inertia.

LINE 38E: Segment Moment of Inertia with Respect to Local y-axis
(only if IMAN = 2 or 3)

DESCRIPTION: Moments of inertia with respect to y-axis for segments 1, 2, 3, 4, 5, 8, 9, and 12 (lb-in.-sec²).

FORMAT AND EXAMPLE:

1	2	3	4	5	6	7	8
1234567890	1234567890	1234567890	1234567890	1234567890	1234567890	1234567890	1234567890
CIY(1)	CIY(2)	CIY(3)	CIY(4)	CIY(5)	CIY(8)	CIY(9)	CIY(12)
.76	.93	.266	.135	.185	1.22	.994	.0177

<u>FIELD</u>	<u>FORMAT</u>	<u>CONTENTS</u>
CIY(1)	F10.0	Lower torso y-axis moment of inertia.
CIY(2)	F10.0	Upper torso y-axis moment of inertia.
CIY(3)	F10.0	Head y-axis moment of inertia.
CIY(4)	F10.0	Upper arm y-axis moment of inertia.
CIY(5)	F10.0	Lower arm y-axis moment of inertia.
CIY(8)	F10.0	Upper leg y-axis moment of inertia.
CIY(9)	F10.0	Lower leg y-axis moment of inertia.
CIY(12)	F10.0	Neck y-axis moment of inertia.

LINE 38F: Segment Moment of Inertia with Respect to Local z-axis
(only if IMAN = 2 or 3)

DESCRIPTION: Moments of inertia with respect to z-axis for segments 1, 2, 3, 4, 5, 8, and 9 (lb-in.-sec²).

FORMAT AND EXAMPLE:

0	1	2	3	4	5	6	7	8
1234567890	1234567890	1234567890	1234567890	1234567890	1234567890	1234567890	1234567890	1234567890
CIZ(1)	CIZ(2)	CIZ(3)	CIZ(4)	CIZ(5)	CIZ(8)	CIZ(9)		
2.32	1.70	.233	.022	.195	.873	.505		

<u>FIELD</u>	<u>FORMAT</u>	<u>CONTENTS</u>
CIZ(1)	F10.0	Lower torso z-axis moment of inertia.
CIZ(2)	F10.0	Upper torso z-axis moment of inertia.
CIZ(3)	F10.0	Head z-axis moment of inertia.
CIZ(4)	F10.0	Upper arm z-axis moment of inertia.
CIZ(5)	F10.0	Lower arm z-axis moment of inertia.
CIZ(8)	F10.0	Upper leg z-axis moment of inertia.
CIZ(9)	F10.0	Lower leg z-axis moment of inertia.

LINE 38G: Contact Surface Radii (only if IMAN = 2 or 3)

DESCRIPTION: Radii of contact surfaces 1, 2, 3, 4, 5, 8, 9, and 12 (in.). (See figure A-9 and table A-1 for human occupant.)

FORMAT AND EXAMPLE:

1	2	3	4	5	6	7	8
XR(1)	XR(2)	XR(3)	XR(4)	XR(5)	XR(6)	XR(8)	XR(12)
4.50	4.50	3.44	1.95	1.85	3.10	2.30	2.30

<u>FIELD</u>	<u>FORMAT</u>	<u>CONTENTS</u>
XR(1)	F10.0	Radius of lower torso contact surface ellipsoid.
XR(2)	F10.0	Radius of upper torso in mid-saggital plane.
XR(3)	F10.0	Radius of head in mid-saggital plane.
XR(4)	F10.0	Radius of upper arm contact surface cylinder.
XR(5)	F10.0	Radius of lower arm contact surface cylinder.
XR(8)	F10.0	Radius of upper leg contact surface cylinder.
XR(9)	F10.0	Radius of lower leg contact surface cylinder.
XR(12)	F10.0	Radius of neck contact surface cylinder.

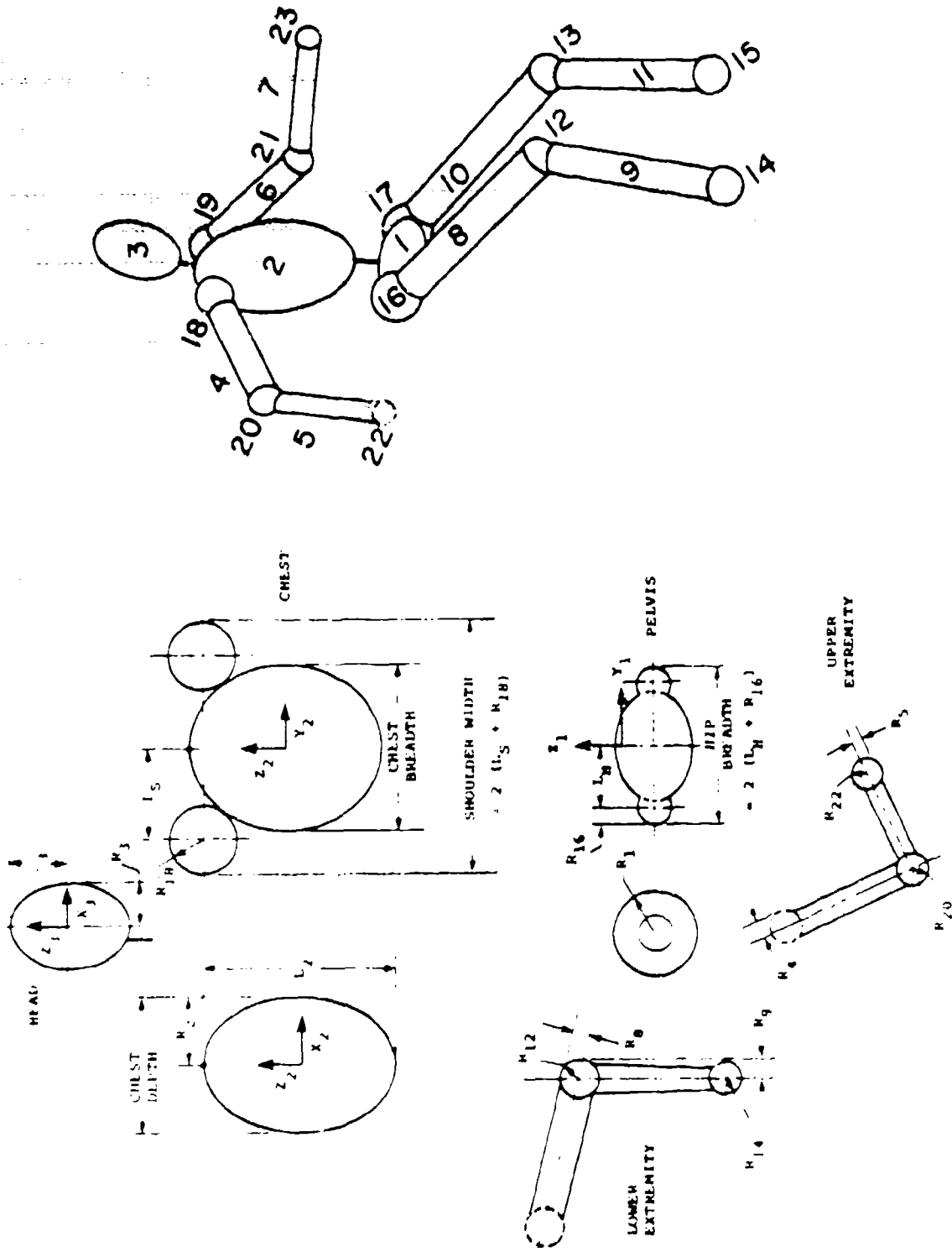

a) Body contact surface dimensions

b) Contact surface identification

Figure A-9. Body contact surfaces description.

TABLE A-1. STANDARD CONTACT SURFACE DIMENSIONS

<u>Surface</u>	<u>Symbol</u>	<u>Fraction of Stature (R_i/S)</u>	<u>Actual Dimension for 50th-Percentile Human Male (in.)</u>
Pelvis	R_1	0.0579	4.00
Chest	R_2	0.0689	4.76
Head	R_3	0.0485	3.35
Arm	R_4, R_6	0.0263	1.82
Forearm	R_5, R_7	0.0243	1.68
Thigh	R_8, R_{10}	0.0466	3.22
Leg	R_9, R_{11}	0.0344	2.38
Knee	R_{12}, R_{13}	0.0373	2.58
Foot	R_{14}, R_{15}	0.0405	3.10
Hip	R_{16}, R_{17}	0.0515	3.56
Shoulder	R_{18}, R_{19}	0.0378	2.61
Elbow	R_{20}, R_{21}	0.0268	1.85
Hand	R_{22}, R_{23}	0.0339	2.34

LINE 38H: Contact Surface Radii Continued (only if IMAN = 2 or 3)

DESCRIPTION: Radii of contact surfaces 14, 16, 18, 20, and 22 (in.).

FORMAT AND EXAMPLE:

0	1	2	3	4	5	6	7	8
1234567890	1234567890	1234567890	1234567890	1234567890	1234567890	1234567890	1234567890	1234567890
XR(14)	XR(16)	XR(18)	XR(20)	XR(22)				
1.60	3.56	2.61	1.85	2.38				

<u>FIELD</u>	<u>FORMAT</u>	<u>CONTENTS</u>
XR(14)	F10.0	Radius of foot contact surface sphere.
XR(16)	F10.0	Radius of hip contact surface sphere.
XR(18)	F10.0	Radius of shoulder contact surface sphere.
XR(20)	F10.0	Radius of elbow contact surface sphere.
XR(22)	F10.0	Radius of hand contact surface sphere.

LINE 38I: Spherical Joint and Center of Mass Offset Distances
(only if IMAN = 2 or 3)

DESCRIPTION: Distances that spherical joints (shoulder and hip) are laterally offset from the mid-saggital plane, and the anterior offset of the major upper body segment (lower torso, upper torso, and head) center of masses from the spine. (See description of distances in figure A-8.) Dimensions are in inches.

FORMAT AND EXAMPLE;

0	1	2	3	4	5	6	7	8
1234567890	1234567890	1234567890	1234567890	1234567890	1234567890	1234567890	1234567890	1234567890
XLH	XLS	EM(1)	EM(2)	EM(3)				
3.70	5.34	.20	.20	2.00				

<u>FIELD</u>	<u>FORMAT</u>	<u>CONTENTS</u>
XLH	F10.0	Lateral distance of center of hip joint from mid-saggital plane.
XLS	F10.0	Lateral distance of shoulder joint from mid-saggital plane.
EM(1)	F10.0	Anterior offset distance of the lower torso center of mass from the spine.
EM(2)	F10.0	Anterior offset distance of the upper torso center of mass from the spine.
EM(3)	F10.0	Anterior offset distance of the head center of mass from the spine.

LINE 38J: Abdomen and Chest Compliance (only if IMAN = 2 or 3)

DESCRIPTION: Estimated force-deflection characteristics (compliance) of occupant chest and abdomen under restraint system loads. The force, F, is computed from cushion deflection, δ , according to $F = C(e^{B\delta} - 1)$.

FORMAT AND EXAMPLE:

0	1	2	3	4	5	6	7	8
1234567890	1234567890	1234567890	1234567890	1234567890	1234567890	1234567890	1234567890	1234567890
CABD	BABD	CCHE	BCHE					
2000	.050	2000	.380					

<u>FIELD</u>	<u>FORMAT</u>	<u>CONTENTS</u>
CABD	F10.0	Coefficient C for abdomen compliance (lb).
BABD	F10.0	Coefficient B for abdomen compliance (in. ⁻¹).
CCHE	F10.0	Coefficient C for chest compliance (lb).
BCHE	F10.0	Coefficient B for chest compliance (in. ⁻¹).

LINE 38K: Axial Stiffness and Damping Properties for Spine and Neck (only if IMAN = 2 or 3)

DESCRIPTION: Axial force-deflection characteristics for the two-dimensional spine and neck beam models and associated axial damping. The force, F , is computed from deflection, δ , according to $F = C(e^{B\delta} - 1)$.

FORMAT AND EXAMPLE:

0	1	2	3	4	5	6	7	8
1234567890	1234567890	1234567890	1234567890	1234567890	1234567890	1234567890	1234567890	1234567890
CAXS	BAXS	DMPS	CAXN	BAXN	DMPN			
6000	.238	1.00	3240	.270	1.0			

<u>FIELD</u>	<u>FORMAT</u>	<u>CONTENTS</u>
CAXS	F10.0	Coefficient C in above equation for axial spinal stiffness (lb).
BAXS	F10.0	Coefficient B in above equation for axial spinal stiffness (in. ⁻¹).
DMPS	F10.0	Axial damping in spine (lb-sec-in. ⁻¹).
CAXN	F10.0	Coefficient C in above equation for axial neck stiffness (lb).
BAXN	F10.0	Coefficient B in above equation for axial neck stiffness (in. ⁻¹).
DMPN	F10.0	Axial damping in neck (lb-sec-in. ⁻¹).

LINE 38L: Rotational Stiffness and Damping Properties for Spine and Neck (only if IMAN = 2 or 3)

DESCRIPTION: Rotational moment-angle characteristics for the two-dimensional spine and neck beam models and associated rotational damping. The moment, M, is computed from angular deflection, δ , according to $M = C(e^{B\delta} - 1)$.

FORMAT AND EXAMPLE:

1	2	3	4	5	6	7	8
1234567890	1234567890	1234567890	1234567890	1234567890	1234567890	1234567890	1234567890
CROT(1)	BROT(1)	XJ(1)	CROT(2)	BROT(2)	XJ(2)		
375.	1.49	150.	375.	1.49	30.		

<u>FIELD</u>	<u>FORMAT</u>	<u>CONTENTS</u>
CROT(1)	F10.0	Coefficient C in above equation for rotational spinal stiffness (in.-lb).
BROT(1)	F10.0	Coefficient B in above equation for rotational spinal stiffness (rad ⁻¹).
XJ(1)	F10.0	Rotational damping in spine (lb-sec).
CROT(2)	F10.0	Coefficient C in above equation for rotational neck stiffness (in.-lb).
BROT(2)	F10.0	Coefficient B in above equation for rotational neck stiffness (rad ⁻¹).
XJ(2)	F10.0	Rotational damping in neck (lb-sec).

LINE 39: Seat Geometry

DESCRIPTION: Dimensions of rigid seat model as shown in figure A-10.

FORMAT AND EXAMPLE:

0	1	2	3	4	5	6	7	8
1234567890	1234567890	1234567890	1234567890	1234567890	1234567890	1234567890	1234567890	1234567890
XSEAT	ZSEAT	ANGSP	ANGSB	XLPAN	XWPAN	SBHT	SBW	
0.	12.75	0.	0.	18.	18.	40.88	18.	

<u>FIELD</u>	<u>FORMAT</u>	<u>CONTENTS</u>
XSEAT ZSEAT	2F10.0	X- and Z-coordinates (in aircraft-fixed system) of intersection of seat pan and seat back planes under the cushions (in.).
ANGSP ANGSB	2F10.0	Seat pan and seat back angles (in aircraft-fixed system), directions as defined in figure A-10 (deg).
XLPAN	F10.0	Seat pan length (in.).
XWPAN	F10.0	Seat pan width (in.).
SBHT	F10.0	Seat back height (in.).
SBW	F10.0	Seat back width at top (in.).

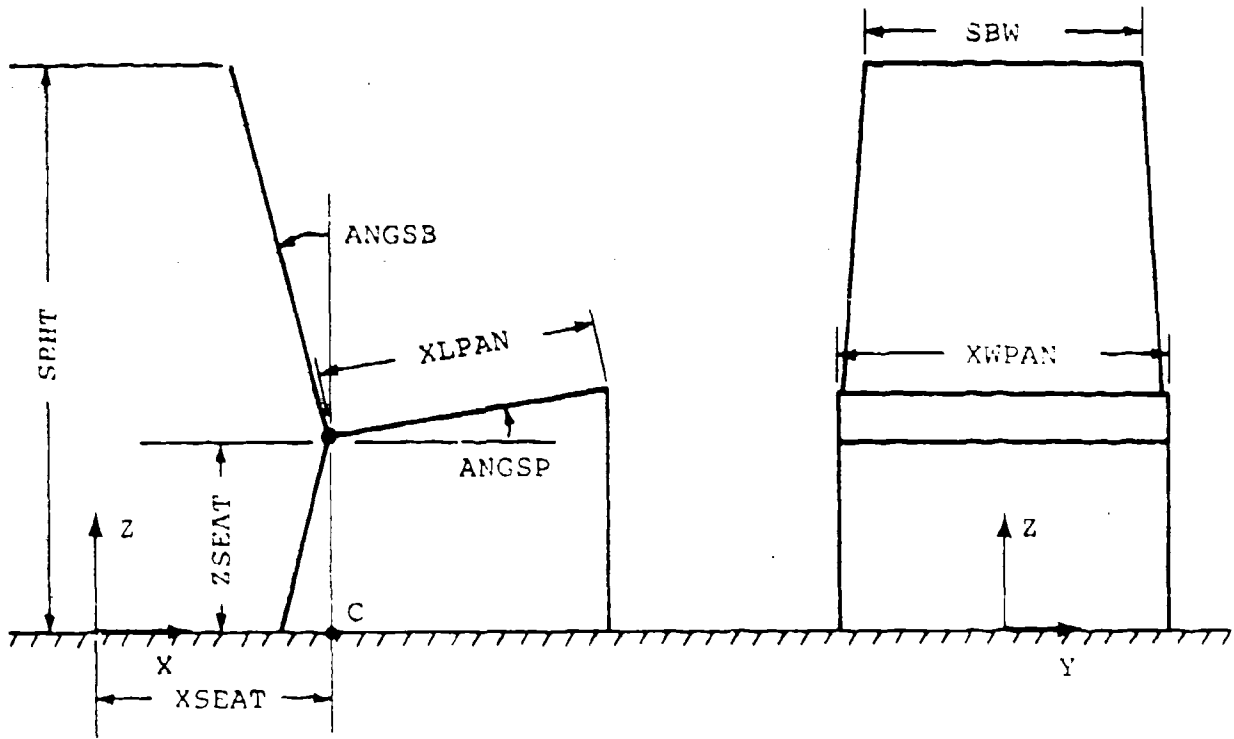

NO 04001 46

Figure A-10. Rigid seat model geometry.

A.1 RIGID SEAT INPUT

If a rigid seat is requested by setting NSEAT = 0 on line 1, then the input data for lines 40 and 41 following this page are required. If the stroking energy-absorbing seat option is utilized, line 42 is also required. If NSEAT = 1, signifying the use of the finite element model, omit these lines and move to section A.2.

LINE 40: Energy Absorber Data

DESCRIPTION: Parameters for the two-degree-of-freedom (seat stroke and rigid-body rotation) energy-absorbing seat model. (See figure A-11 for a detailed description of the parameters.)

FORMAT AND EXAMPLE:

0	1	2	3	4	5	6	7	8
1234567890	1234567890	1234567890	1234567890	1234567890	1234567890	1234567890	1234567890	1234567890
F2	F3	F4	D2	D3	D4	ANGEA	SEATM	

<u>FIELD</u>	<u>FORMAT</u>	<u>CONTENTS</u>
F2 F3 F4	3F10.0	Energy absorber force (lb).
D2 D3 D4	3F10.0	Deflections corresponding to above forces (in.), see figure A-11a.
ANGEA	F10.0	Stroking angle for guided energy-absorbing seat (deg), see figure A-11b.
SEATM	F10.0	Weight of movable part of energy-absorbing seat (lb).

NOTE: If SEATM \leq 0 (or left blank) the energy-absorbing stroke of the seat will not be used, i.e., the seat will remain fixed in position. However, lines 40 and 41 must be included, even if blank.

*Line not present for sample case.

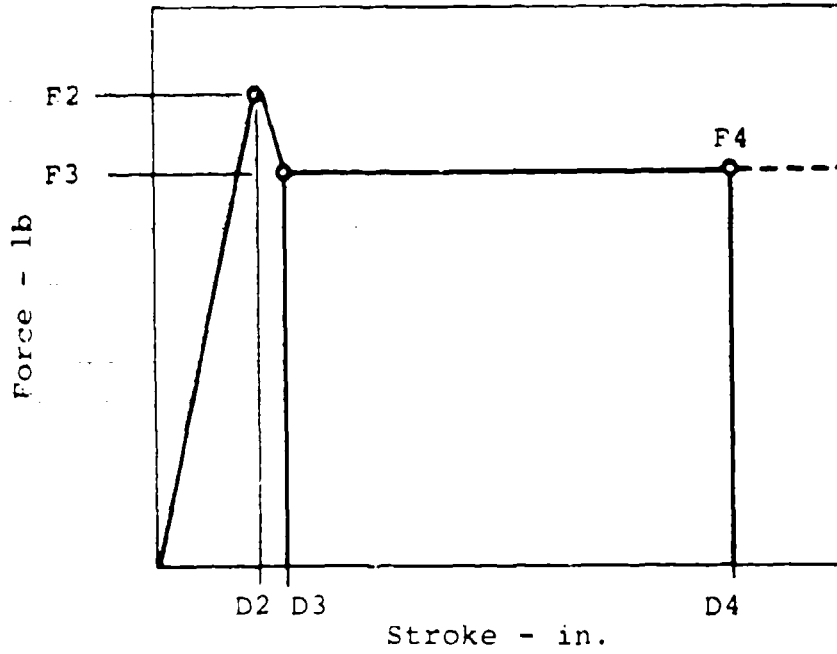

80 04001 47

a) Force-stroke characteristics

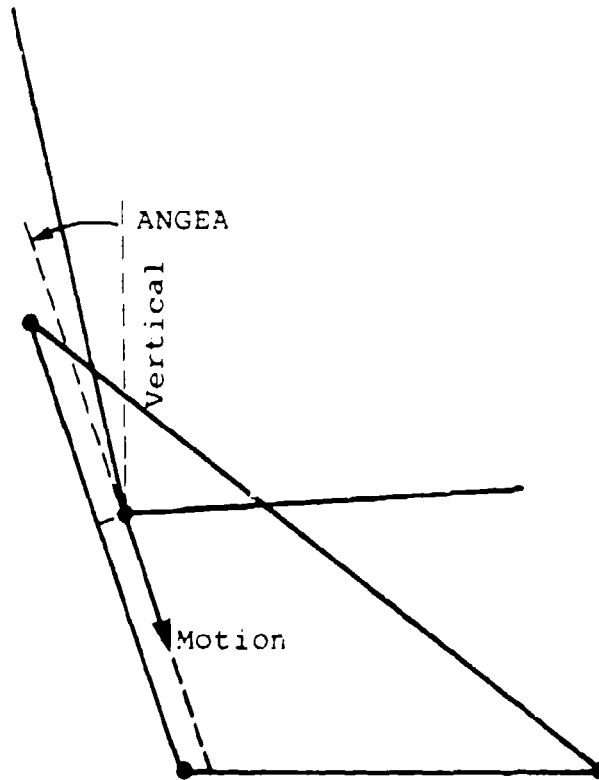

b) Geometry

Figure A-11. Energy absorber data.

LINE 41: Energy Absorber Data Continued

DESCRIPTION: Parameters for the two-degree-of-freedom (seat stroke and rigid-body rotation) energy-absorbing seat model.

FORMAT AND EXAMPLE:

0	1	2	3	4	5	6	7	8
1234567890	1234567890	1234567890	1234567890	1234567890	1234567890	1234567890	1234567890	1234567890
SUNLOD	SDAMP	YISEAT	RUNLOD	RDAMP				

<u>FIELD</u>	<u>FORMAT</u>	<u>CONTENTS</u>
SUNLOD	F10.0	Energy absorber unloading slope (lb/in.)
SDAMP	F10.0	Damping coefficient for the energy absorber (lb-sec/in.).
YISEAT	F10.0	Mass moment of inertia of the seat about a lateral axis through point C (in figure A-10) with coordinates X = XSEAT, Z = 0 (lb-in.-sec ²).
RUNLOD	F10.0	Unloading slope for rotational deformation of seat (in.-lb/rad)
RDAMP	F10.0	Rotational damping coefficient for the seat (in.-lb-sec).

*Line not present for sample case.

LINE 42: Rigid Seat Rotational Stiffness Parameters

DESCRIPTION: Applied moment versus seat rotational angle as shown in figure A-12.

FORMAT AND EXAMPLE:

0	1	2	3	4	5	6	7	8
1234567890	1234567890	1234567890	1234567890	1234567890	1234567890	1234567890	1234567890	1234567890
FFRT(2)	FFRT(3)	FFRT(4)	DDRT(2)	DDRT(3)	DDRT(4)			

<u>FIELD</u>	<u>FORMAT</u>	<u>CONTENTS</u>
FFRT(2)	3F10.0	Applied moment on rigid seat (in.-lb).
FFRT(3)		
FFRT(4)		
DDRT(2)	3F10.0	Angular seat displacement (rad).
DDRT(3)		
DDRT(4)		

*Line not present for sample case.

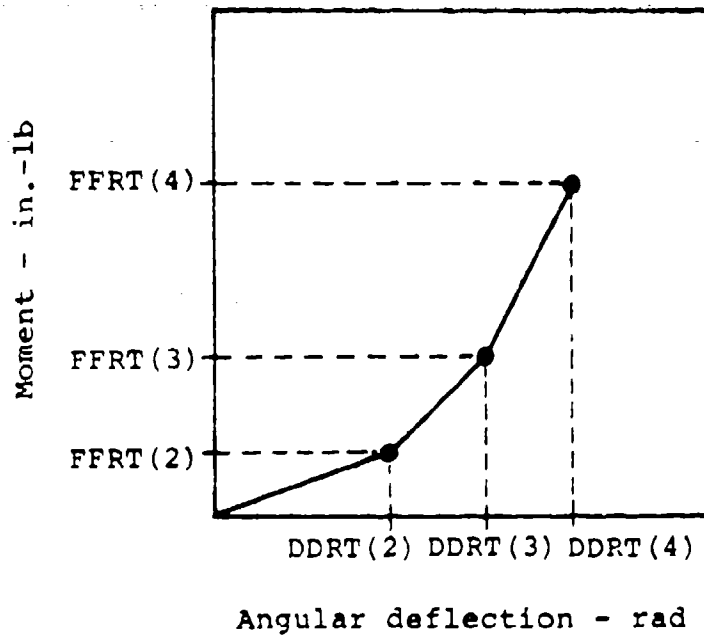

81 09003 08

Figure A-12. Rigid seat model rotational stiffness.

A.2 NONRIGID SEAT INPUT

If a nonrigid seat is requested by setting NSEAT = 1 on line 1, then the input data described on the following lines is required to define the finite element seat model, beginning with line 40. (The energy-absorbing seat data described previously for lines 40, 41, and 42 are then not required.)

LINE 40: Basic Seat Model Data

DESCRIPTION: Control line for finite element model describing the number of items in each segment of the model (used to control reading of input cards) and the integration parameters.

FORMAT AND EXAMPLE:

1		2		3		4		5		6		7		8	
1234567890	1234567890	1234567890	1234567890	1234567890	1234567890	1234567890	1234567890	1234567890	1234567890	1234567890	1234567890	1234567890	1234567890	1234567890	1234567890
NNODE	NELE	NUMMAT	NUMDIS	NDGREE	NCOORD	NSECT	CBUK								
15	21	1	4	6	2	3	.50								

<u>FIELD</u>	<u>FORMAT</u>	<u>CONTENTS</u>
NNODE	I5	Number of real nodes.
NELE	I5	Number of elements.
NUMMAT	I5	Number of materials.
NUMDIS	I5	Number of displacement-specified node points (at which the aircraft displacement, velocity, and acceleration are applied).
NDGREE	I5	Number of degrees of freedom per node (= 6 this version).
NCOORD	I5	Number of inactive beam pointer nodes, which are used to orient beam cross sections, as explained in section 2.7.3. A real node can be used as a pointer node. Also, a single node can be used as a pointer node for more than one beam.
NSECT	I5	Number of different beam cross-section types.
CBUK	F5.0	Buckling coefficient for beams of closed cross-section.

LINE 41: Miscellaneous Control Flags

DESCRIPTION: Parameters for controlling execution of finite element seat simulation.

FORMAT AND EXAMPLE:

0	1	2	3	4	5	6	7	8
1234567890	1234567890	1234567890	1234567890	1234567890	1234567890	1234567890	1234567890	1234567890
KNTRL(1)								
1								

<u>FIELD</u>	<u>FORMAT</u>	<u>CONTENTS</u>
KNTRL(1)	I5	Stiffness matrix update. A value of 1 indicates that the stiffness matrix will be updated every time step after plastic yielding has been initiated in any element. A higher number specifies less frequent updates, e.g., KNTRL(1) = 5 would cause an update every fifth time step, producing a more economical but less accurate solution.

LINE 42: Material Type Number

DESCRIPTION: Material type designation number. Repeat group 42 through 44 in sequence NUMMAT times, as specified on line 40, one sequence for each material.

FORMAT AND EXAMPLES:

0	1	2	3	4	5	6	7	8
1234567890	1234567890	1234567890	1234567890	1234567890	1234567890	1234567890	1234567890	1234567890
MYTP	MAT							
	11010 STEEL							

<u>FIELD</u>	<u>FORMAT</u>	<u>CONTENTS</u>
MYTP	I5	Material type designation number. The element data on line 48 specifies the material by referring to this number.
MAT	A10	Material type description used as heading for material property output.

LINE 43: Material Properties

DESCRIPTION: Material physical properties as described in figure A-13.

FORMAT AND EXAMPLE:

0	1	2	3	4	5	6	7	8
1234567890	1234567890	1234567890	1234567890	1234567890	1234567890	1234567890	1234567890	1234567890
E(1)	E(2)	E(3)	E(4)	E(5)	E(6)	E(7)	E(8)	
7.324-04	30.E6	58700.	2.9E5	.1	67000.	.3		.03

FIELD FORMAT CONTENTS FOR BEAM OR PLATE ELEMENT

- E(1) E10.4 Density (lb-sec²/in.⁴).
- E(2) E10.4 Modulus of elasticity (lb/in.²).
- E(3) E10.4 First yield stress; s_{y1} (lb/in.²)
= 0 if elastic.
- E(4) E10.4 First plastic modulus (lb/in.²)
= 0 if elastic.
- E(5) E10.4 Plate thickness (in.).
- E(6) E10.4 Ultimate stress; s_{ult} (lb/in.²)
(beam only)
= 0 if elastic.
- E(7) E10.4 Poisson's ratio.
- E(8) E10.4 Membrane damping as fraction of
critical.

FIELD FORMAT CONTENTS FOR SPRING ELEMENT

- E(1) E10.4 Not used.
- E(2) E10.4 Elastic spring constant (lb/in.).
- E(3) E10.4 First yield force (lb)
= 0 if elastic.
- E(4) E10.4 First plastic spring constant (lb/in.).
- E(5) E10.4 Not used.

<u>FIELD</u>	<u>FORMAT</u>	<u>CONTENTS FOR SPRING ELEMENT</u>
E(6)	E10.4	Ultimate force (lb) = 0 if elastic.
E(7)	E10.4	Not used.
E(8)	E10.4	Not used.

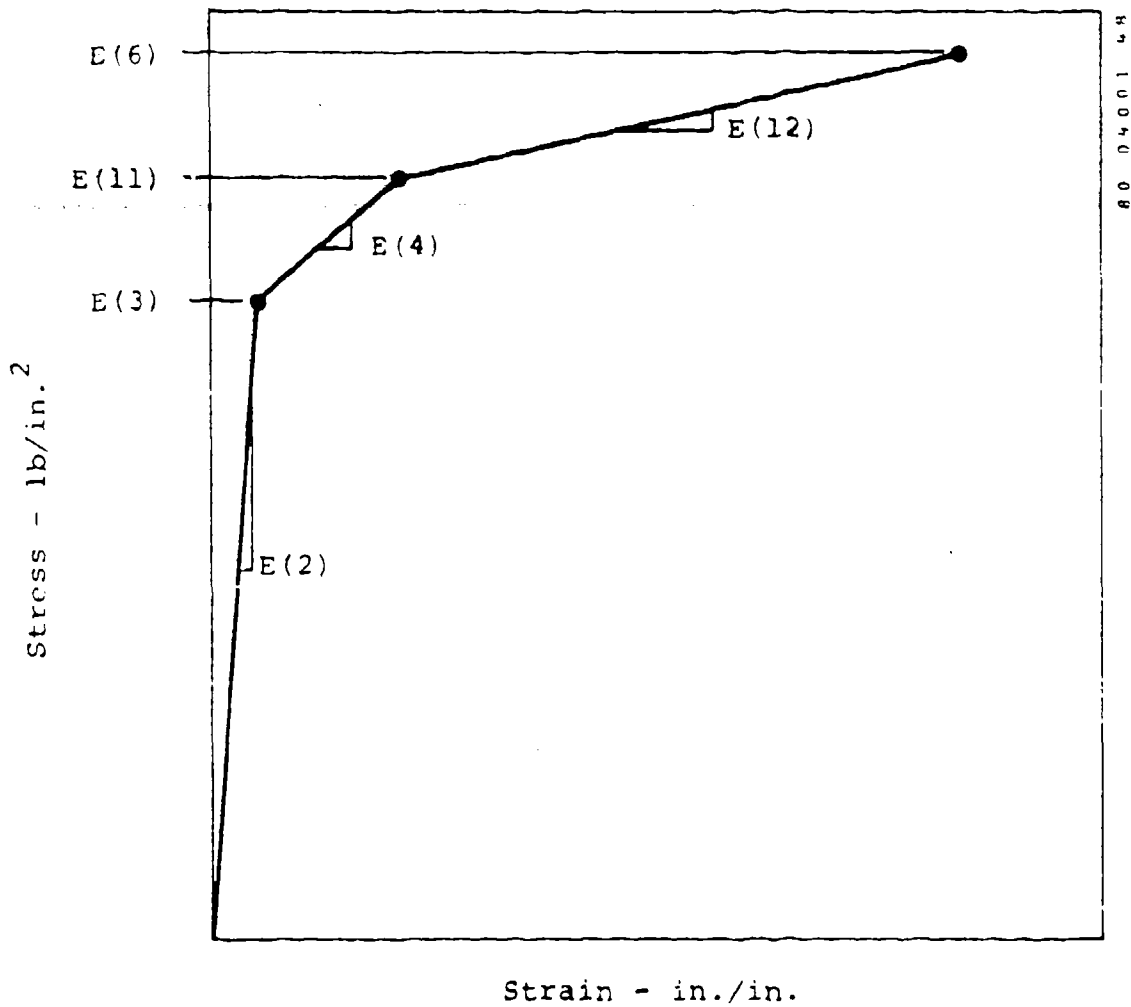

Figure A-13. Idealized stress-strain curve.

LINE 44: Material Properties (continued)

DESCRIPTION: Material physical properties as described in figure A-13. (Repeat group 42 through 44 NUMMAT times.)

FORMAT AND EXAMPLE:

0	1	2	3	4	5	6	7	8
1234567890	1234567890	1234567890	1234567890	1234567890	1234567890	1234567890	1234567890	1234567890
E(9)	E(10)	E(11)	E(12)	E(13)	E(14)	E(15)	E(16)	E(17)
		62500.	75000.					

<u>FIELD</u>	<u>FORMAT</u>	<u>CONTENTS FOR BEAM OR PLATE ELEMENT</u>
E(9)	E10.4	None.
E(10)	E10.4	None.
E(11)	E10.4	Second yield stress, s_{y2} (lb/in. ²).
E(12)	E10.4	Second plastic modulus (lb/in. ²).
E(13)	E10.4	Strain-rate coefficient = 0, no strain-rate effect considered.
E(14)	E10.4	Strain-rate exponent = 0, no strain-rate effect considered.
E(15)	E10.4	Explicit moment curvature flag 1, use explicit moment curvature option (plate) 0, ignored explicit moment curvature option (plate).
E(16)	E10.4	None.
<u>FIELD</u>	<u>FORMAT</u>	<u>CONTENTS FOR SPRING ELEMENT</u>
E(9)	E10.4	None.
E(10)	E10.4	None.
E(11)	E10.4	Second yield force (lb).
E(12)	E10.4	Second plastic spring constant (lb/in.).
E(13)	E10.4	Strain-rate coefficient = 0, no strain-rate effect considered.

<u>FIELD</u>	<u>FORMAT</u>	<u>CONTENTS FOR SPRING ELEMENT</u>
E(14)	E10.4	Strain-rate exponent = 0, no strain-rate effect considered.
E(15)	E10.4	Not used.
E(16)	E10.4	Not used.

LINE 45: Beam Cross-Section Data (only if NSECT > 0 on line 40)

DESCRIPTION: Beam element cross-sectional properties as described in figure A-14. Repeat group 45 and 46 NSECT times, as specified on line 40, one sequence for each cross section.

FORMAT AND EXAMPLE:

1		2		3		4		5		6		7		8	
NSEG	KLOS	FIYY	FIZZ												
8	0	.0219	.0219												

<u>FIELD</u>	<u>FORMAT</u>	<u>CONTENTS</u>
NSEG	I5	Number of plate segments in beam cross section; NSEG = 1 for spring element.
KLOS	I5	Flag for closed-wall sections; KLOS = 0 for spring element = 0; closed wall = 1; open wall.
FIYY FIZZ	2E10.4	Cross-section moments of inertia about y and z principal axes, respectively. The cross section for each beam element is oriented by specification of a pointer node in the element data on line 48. = 0 for spring element (lb-sec ² -in.). (See figure A-14b.)

*Example for first of three groups, determined by NSECT = 3 on line 40.

80 04001 49

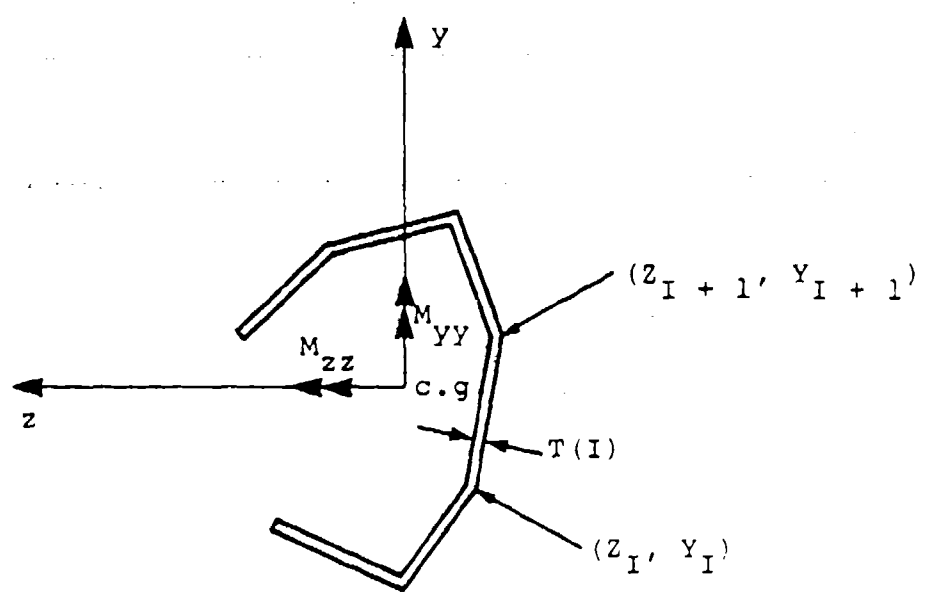

a) Cross-section geometry and moments (positive face, looking down x-axis toward origin)

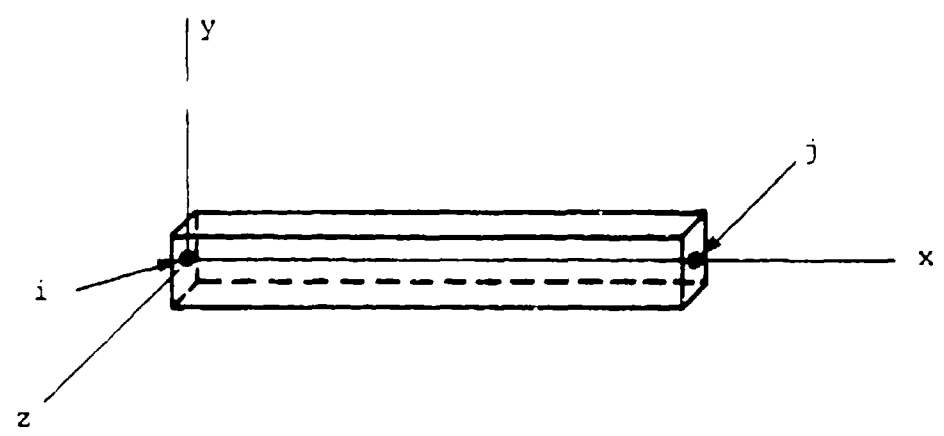

b) Element coordinate system

Figure A-14. Beam coordinates and cross-section geometry.

LINE 46: Beam Cross-Section Data (only if NSECT > 0 on Line 40)

DESCRIPTION: Beam element cross-sectional properties as described in figure A-14.

NOTES: (1) Repeat line 46 NSEG + KLOS times, following line 45.
 (2) Repeat the sequence of lines 45 and 46 NSECT times, as defined on line 40.

FORMAT AND EXAMPLE: *

0	1	2	3	4	5	6	7	8
1	2	3	4	5	6	7	8	9
Y(I)	Z(I)	T(I)						
.466	0.	.0685						

<u>FIELD</u>	<u>FORMAT</u>	<u>CONTENTS</u>
Y(I)	E10.0	Cross-section coordinates of point at beginning of segment I (in.). (See figure A-14a.)
Z(I)	E10.0	
T(I)	E10.0	Segment thickness for segment between points I and I + 1 (in.). = 0 for spring element.

*Example for first of eight lines based on NSEG = 8 and KLOS = 0 on line 45.

LINE 47: Nodal Point Data

DESCRIPTION: Finite element node number, nodal coordinates in global system, and nodal mass properties.

NOTES: Repeat line 47 NNODE + NCOORD times.

FORMAT AND EXAMPLE: *

0	1	2	3	4	5	6	7	8
1234567890	1234567890	1234567890	1234567890	1234567890	1234567890	1234567890	1234567890	1234567890
N		XC(N)	YC(N)	ZC(N)				
1		0.	-9.	0.				

<u>FIELD</u>	<u>FORMAT</u>	<u>CONTENTS</u>
N	I5 5X	Node number.
XC(N)	E10.4	X
YC(N)	E10.4	Y coordinates of node point (in.).
ZC(N)	E10.4	Z

*Example for first of 20 lines, based on NNODE = 18 and NCOORD = 2 on line 40.

LINE 48: Element Data

DESCRIPTION: Individual element property descriptions.

NOTE: Repeat line 48 NELE times.

FORMAT AND EXAMPLE:*

0	1	2	3	4	5	6	7	8
1234567890	1234567890	1234567890	1234567890	1234567890	1234567890	1234567890	1234567890	1234567890
M	NODE(1)	NODE(2)	NODE(3)	NODE(4)	NODE(5)	NODE(6)	NODE(7)	NODE(8)
1	1	5				1	4	2

<u>FIELD</u>	<u>FORMAT</u>	<u>CONTENTS FOR PLATE ELEMENT</u>
M	I5	Element number.
NODE(1)	3I5	Plate corner nodes.
NODE(2)		
NODE(3)		
NODE(4)	I5	Not used.
NODE(5)	I10	
NODE(6)	I5	
NODE(7)	I5	
NODE(8)	I5	Element type = 0 or 1; plate = 2; beam = 3; spring.
NODE(9)	I5	Material type (assumes 1 if left blank). Material properties are assigned to types on lines 42-44.

<u>FIELD</u>	<u>FORMAT</u>	<u>CONTENTS FOR BEAM OR SPRING ELEMENT</u>
M	I5	Element number.
NODE(1)	2I5	End nodes.
NODE(2)		

*Example for first of 21 lines, based on NELE = 21 on line 40.

<u>FIELD</u>	<u>FORMAT</u>	<u>CONTENTS FOR BEAM OR SPRING ELEMENT</u>
NODE(5)	I10	<p>Special beam end conditions - packed word. Input data here permits introduction of releases such as hinges and sliding joints, illustrated in figure A-15.</p> <p>NABCDEF G (right justified)</p> <p>N = Location of device in percent of the total length measured from the ith end of a beam ranging from 0 to 100</p> <p>A = Force release in \hat{X} direction if 1, figure A-15(a)</p> <p>B = Force release in \hat{Y} direction if 1, figure A-15(b)</p> <p>C = Force release in \hat{Z} direction if 1, figure A-15(c)</p> <p>D = Moment release in \hat{X} direction if 1, figure A-15(d)</p> <p>E = Moment release in \hat{Y} direction if 1, figure A-15(e)</p> <p>F = Moment release in \hat{Z} direction if 1, figure A-15(f)</p> <p>G = Use elastic beam stiffness if 1 Use plastic beam stiffness if 0.</p> <p><u>NOTE:</u> \hat{X}, \hat{Y}, \hat{Z} are the member axes.</p>
NODE(6)	I5	Cross-section type. The first set of lines 45 and 46 is assumed to be cross-section type no. 1; the second, no. 2, etc.
NODE(7)	I5	Pointer node for orientation of initial principal beam axis \hat{Y} , as described in section 2.7.3.
NODE(8)	I5	Element type = 0 or 1; plate = 2; beam = 3; spring.
NODE(9)	I5	Material type (assumes 1 if left blank).

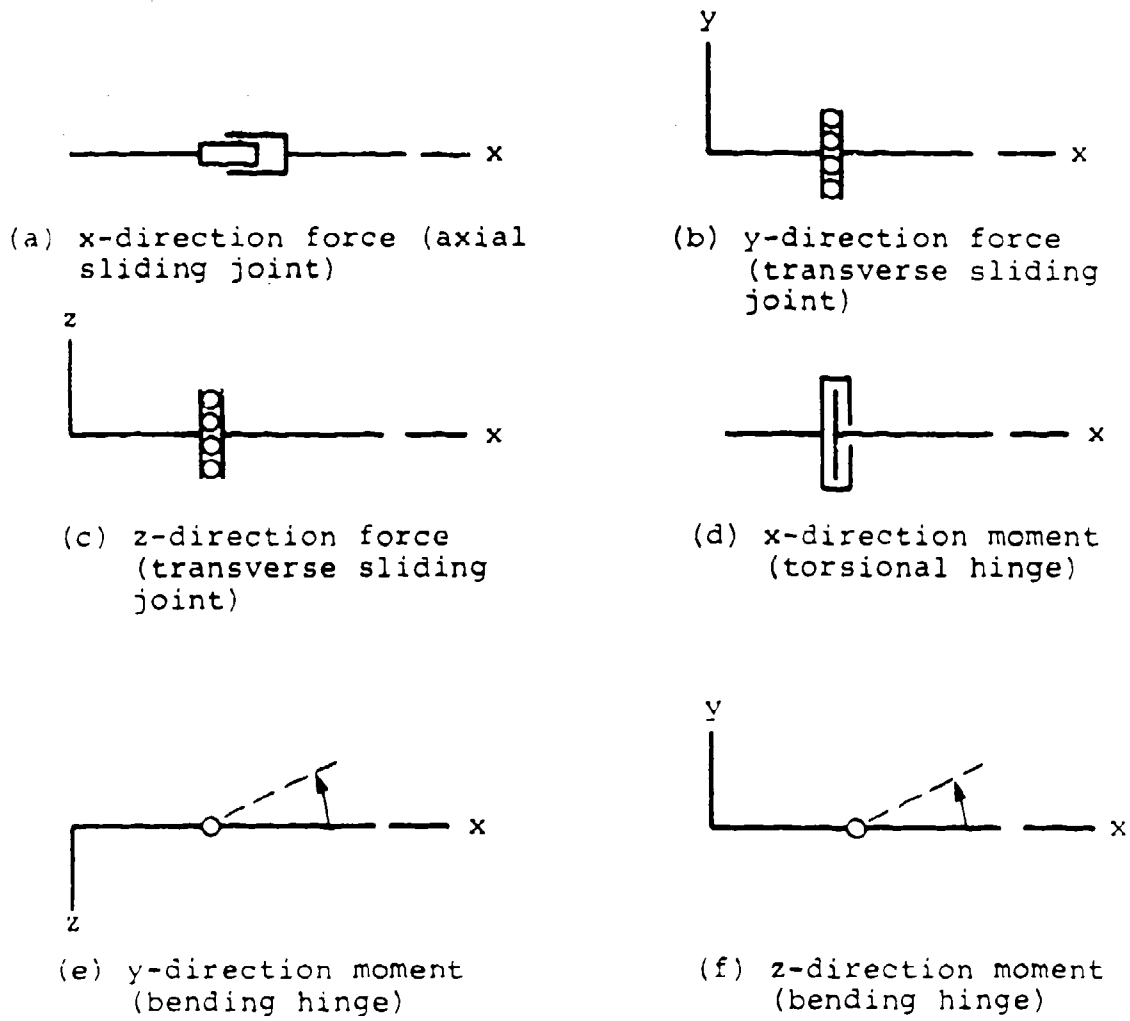

A1 09003 29

Figure A-15. Force and moment releases for beam elements.

LINE 49: Seat Pan Nodes

DESCRIPTION: Nodes on which seat cushion loads will be applied, and which are used to define the seat pan outline for the occupant plots.

FORMAT AND EXAMPLE:

0	1	2	3	4	5	6	7	8
1234567890	1234567890	1234567890	1234567890	1234567890	1234567890	1234567890	1234567890	1234567890
NPAN(1)	NPAN(2)	NPAN(3)	NPAN(4)					
15	16	14	13					

<u>FIELD</u>	<u>FORMAT</u>	<u>CONTENTS</u>
NPAN(1)	4I5	Nodes on which seat cushion loads are to be applied, input on rear edge first, then forward edge, as shown in figure A-16.
NPAN(2)		
NPAN(3)		
NPAN(4)		

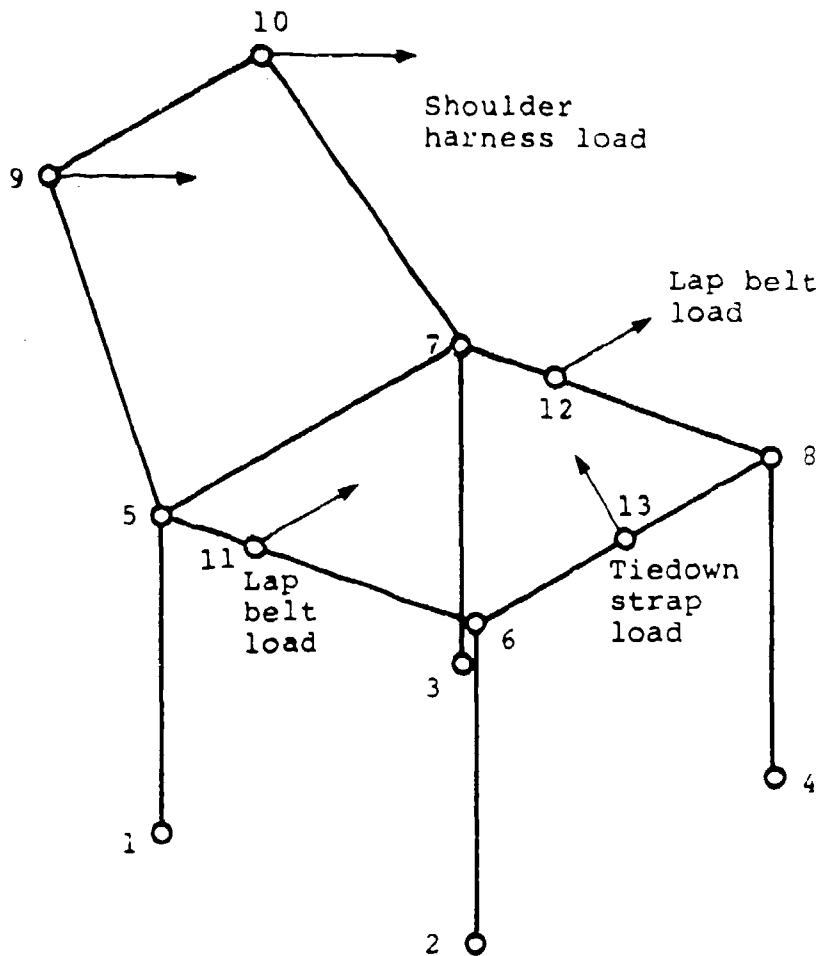

80 04001 50

Input Line	1-5	6-10	11-15	16-20	20-25
Line 49, Seat Pan Nodes	5	7	6	8	
50, Seat Back Nodes	5	7	9	10	
51, Restraint System Anchor Point Nodes	11	12	9	10	13

Figure A-16. Illustration of seat node definition on lines 49-51.

LINE 50: Seat Back Nodes

DESCRIPTION: Nodes on which back cushion loads are to be applied, and which are used to define the seat back outline for the occupant plots.

FORMAT AND EXAMPLE:

0	1	2	3	4	5	6	7	8
1234567890	1234567890	1234567890	1234567890	1234567890	1234567890	1234567890	1234567890	1234567890
NBAK(1)	NBAK(2)	NBAK(3)	NBAK(4)					
15	16	17	18					

<u>FIELD</u>	<u>FORMAT</u>	<u>CONTENTS</u>
NBAK(1)	4I5	Nodes on which back cushion loads are to be applied, input on lower edge first, then top, as shown in figure A-16.
NBAK(2)		
NBAK(3)		
NBAK(4)		

LINE 51: Restraint System Anchor Point Nodes

DESCRIPTION: Nodal points on seat structure to which restraint system is attached as shown in figure A-16.

NOTES: NLBA(1) and NLBA(2) are required only if ILPBLT = 1 on line 6. NSHA(1) and NSHA(2) are required only if IRSYS > 0 and ISHRNS = 1 on line 6. NTD is required only if IRSYS = 4 on line 6. Otherwise, leave these fields blank.

FORMAT AND EXAMPLE:

1		2		3		4		5		6		7		8	
0	1	2	3	4	5	6	7	8	9	0	1	2	3	4	5
1	2	3	4	5	6	7	8	9	0	1	2	3	4	5	6
NLBA(1)	NLBA(2)	NSHA(1)	NSHA(2)	NTD											
14	16	17	18												

<u>FIELD</u>	<u>FORMAT</u>	<u>CONTENTS</u>
NLBA(1)	I5	Seat structure nodes at which lap belt is attached, right side first, then left, as shown in figure A-16. Leave blank if lap belt is attached to aircraft floor.
NLBA(2)	I5	
NSHA(1)	I5	Seat structure nodes at which shoulder harness load is to be applied (one node), or distributed (two nodes). Leave blank if shoulder harness is not used or not attached to seat.
NSHA(2)	I5	
NTD	I5	Seat structure nodes at which tiedown strap load is to be applied. Leave blank if tiedown strap is not used.

LINE 52: Node Constraint Data

DESCRIPTION: Packed (encoded) word for each nodal point that is constrained in at least one degree of freedom.

NOTE: (1) Repeat line 52 NUMDIS times. Omit if NUMDIS = 0.
 (2) Normally, the floor attachment conditions are specified here.

FORMAT AND EXAMPLE:*

1	2	3	4	5	6	7	8
1234567890	1234567890	1234567890	1234567890	1234567890	1234567890	1234567890	1234567890
NODDIS							
1111101							

<u>FIELD</u>	<u>FORMAT</u>	<u>CONTENTS</u>
NODDIS	I10	Packed word - NABCDEF (right justified)
		N = Node number
		A = Displacement code in X direction
		B = Displacement code in Y direction
		C = Displacement code in Z direction
		D = Rotation code in X direction
		E = Rotation code in Y direction
		F = Rotation code in Z direction
		A, B, C, D, E, or F = 0, No constraint
		= 1, constrained.

*Example for first of four lines, based on NUMDIS = 4 on line 40.

APPENDIX B

EXAMPLES OF OCCUPANT CHARACTERISTICS AND MATERIAL PROPERTIES

A significant problem encountered in mathematically modeling a physical system lies in determination of system characteristics and properties. In this appendix are presented examples of the following:

- Occupant dimensions and characteristics.
- Restraint system webbing load-elongation characteristics.
- Cushion load-deflection characteristics.
- Structural material stress-strain characteristics.

The characteristics and properties contained in this appendix are, of course, not intended to be all inclusive, but rather are intended to provide the SOM-LA program user with examples that may aid in setting up new input cases.

B.1 OCCUPANT MODELING CHARACTERISTICS

As described in chapter 2, dimensions and inertial properties for two standard occupants, a 50th-percentile civilian male and a 50th-percentile anthropomorphic (Part 572) dummy, are included within the program. If a nonstandard occupant is desired, additional data must be provided on lines 38A through 38L. The format for nonstandard occupant data is displayed in figure B-1, and parameters are defined on pages A-38 through A-53. On figure B-2 are presented the properties that are used in the program for the standard (Part 572 50th-percentile) dummy occupant. Figure B-3 presents a set of data for a 95th-percentile dummy, which have simply been scaled from the 50th-percentile data. The use of this scaling method is not suggested if measured properties can be obtained; however, to complete a partial set of properties or obtain a quick estimate of the solution, use of the scaling approach can be justified.

The scaling method is based on multiplying the 50th-percentile properties by the appropriate nondimensional scaling factor. All properties with length dimensions are multiplied by the ratio of nonstandard occupant sitting height to 50th-percentile sitting height. In this example:

$$\text{Length Factor} = \frac{95\text{th \% Sitting Height}}{50\text{th \% Sitting Height}} = \frac{37.8 \text{ in.}}{35.7 \text{ in.}} = 1.06$$

Similarly, occupant properties based on weight are scaled by the occupant weight ratio, i.e.:

$$\text{Weight Factor} = \frac{95\text{th \% Weight}}{50\text{th \% Weight}} = \frac{212 \text{ lb}}{164 \text{ lb}} = 1.29$$

The factor for scaling moments of inertia was derived from a dimensional analysis for the variables involved. The resulting scaling factor is:

$$\text{Moment of Inertia Factor} = \frac{(95\text{th \% Weight}) (95\text{th \% Sitting Height})^2}{(50\text{th \% Weight}) (50\text{th \% Sitting Height})^2} = 1.45$$

Since there is no valid basis for scaling stiffnesses, the 50th-percentile spine and neck stiffness properties were retained.

B.2 WEBBING LOAD-ELONGATION CHARACTERISTICS

Figures B-4 and B-5 present static load-elongation characteristics for several types of nylon and polyester restraint system webbing, respectively. Very little dynamic data for webbing deformation exist; however, figures B-6 and B-7 present some dynamic results taken from reference B.1.

The damping coefficients for the restraint components are based on three assumptions: that the webbing damping coefficient is not a function of strain condition, that it is independent of strain rate, and that the Voigt-Kelvin model (shown in figure B-8) can be used to represent the webbing.

The first assumption allows the use of a linear approximation to the static and dynamic load-strain curves for the webbing material. The single slope approximation should be the best estimate for the expected range of webbing loads, and not for the entire curve. The second assumption indicates that the damping coefficient will be applicable to all possible strain rates encountered in the simulation. The accuracy of the damping coefficient can be maximized by basing the calculated value on dynamic webbing test data measured at an applicable strain rate. The procedure for calculating the damping coefficient for nylon webbing (MIL-W-4088 TYPE VII) is given below.

The static load/elongation curve for the nylon webbing sample is shown in figure B-9. A linear approximation to this curve is 11,000 lb/in./in. over the expected load range of 0 to 2000 lb. The slope of the dynamic test data, measured at a strain rate of 40.9 in./in./sec, is approximated as 26,000 lb/in./in. Based on the assumption of a parallel spring-damper model, the dynamic load at any elongation value must be equal to the static load plus the damper force, i.e.

$$\begin{aligned} P_{\text{DYNAMIC}} &= P_{\text{STATIC}} + P_{\text{DAMPING}} \\ &= KE + C\dot{E} \end{aligned} \quad (\text{B-1})$$

Where:

K is slope of the load/strain curve (lb/in./in.)
C is the damping coefficient (lb-sec/in./in.)

\dot{E} is the strain (in./in.)
 E is the strain rate (in./in./sec)

Therefore, the damping coefficient can be calculated using

$$C = \frac{P_{\text{DYNAMIC}} - KE}{\dot{E}} \quad (\text{B-2})$$

Using as representative point a dynamic load of 2000 lb and 0.0825 in./in. strain, the damping coefficient for the nylon webbing is calculated as

$$\begin{aligned} C &= \frac{2000 \text{ lb} - (11,00 \text{ lb/in./in.})(.0825 \text{ in./in.})}{40.9 \text{ in./in./sec}} \\ &= 26.7 \frac{\text{lb} - \text{sec}}{\text{in./in.}} \end{aligned}$$

B.3 CUSHION LOAD-DEFLECTION-CHARACTERISTICS

The seat cushion represented in Program SOM-LA accounts for the stiffness and damping properties of the cushion combined with the occupant buttocks. This modeling approach is desirable in order to avoid the numerical problems associated with springs in a series configuration. An experiment was performed to develop load-deflection properties for representative cushions. The experiment consisted of applying a known static load in the downward direction to the lower torso segment of an Alderson VIP-95 dummy. This downward load, which was applied at the spine base plate, caused both the buttocks and cushion to deform. The deflections of the combined system, buttocks and cushion, and the buttocks separately were measured for each applied load.

A description of the cushions used in load-deflection tests is given in table B-1. The cushions were selected to provide a spectrum of the possible cushion configurations that the user may select. Combined load-deflection curves for the VIP-95 buttocks and cushions are presented in figures B-10 through B-14. The form that the load-deflection curves take is a linear slope followed by an exponential stiffening as the cushion and occupant "bottom out." These curves can be approximated by an expression of the form:

$$F = C(e^{B\delta} - 1) \quad (\text{B-3})$$

Representing the load-deflection curves with a smooth function alleviates a convergence problem encountered previously with the numerical integration around the slope-change points of a piecewise, linear representation. The exponential representation of the five load-deflection curves, developed with a least-squares approximation routine, is presented as the dashed line in each figure. Also presented in this section are the separate load-deflection curves (figure B-15) for the Alderson VIP-95 dummy buttocks when tested with each of the five cushion types. This is presented for the user who may want to synthesize a combined

load-deflection curve by adding the desired cushion properties determined under a rigid indenter to an average deflection curve for the dummy buttocks. The indenter should be configured like the dummy.

TABLE B-1. TYPE DESIGNATION AND DESCRIPTION OF CUSHIONS FOR LOAD-DEFLECTION CURVES

Type Number	Description
1	Contoured, multilayered cushion designed to minimize occupant rebound in crash situation.
2	Contoured, rigid foam cushion designed for negligible deflection.
3	Contoured furniture foam cushion approximately 1.5 in. thick (undeformed) over buttock contact area.
4	Furniture foam slab, 1.2 lb/ft ³ density, approximately 3.0 in. thick (undeformed).
5	Furniture foam slab, 1.4 lb/ft ³ density, approximately 3.0 in. thick (undeformed).

B.4 STRUCTURAL MATERIAL STRESS-STRAIN CURVES

Figures B-16 through B-20 present approximated stress-strain curves for three steels and two aluminum alloys. From each of these curves, six characteristics are provided as input to the finite element seat model.

B.5 REFERENCES

- B.1. Kourouklis, G., Glancy, J. L., and Desjardins, S. P., The Design, Development, and Testing of an Aircraft Restraint System for Army Aircraft, Dynamic Science, Division of Ultrasystems, Inc.; USAAMRDL Technical Report 72-26, Eustis Directorate, U.S. Army Air Mobility Research and Development Laboratory, Fort Eustis, Virginia, June 1971, AD 746631.

10.85	8.35	11.3	13.3	16.5	18.0		
4.67	6.35	6.33	4.72	6.26	8.35	10.96	
34.6	36.0	10.1	4.85	4.85	21.7	9.49	1.98
2.32	2.18	0.275	0.132	0.017	0.127	0.994	
0.760	0.926	0.266	0.135	0.185	1.22	0.994	0.0177
2.32	1.70	0.233	0.022	0.195	.873	0.505	
4.50	4.50	3.44	1.95	1.85	3.10	2.30	2.35
1.60	3.56	2.61	1.85	2.34			
3.70	6.34	0.20	0.20	2.00			
2000.	.050	2000.	0.380				
6000.	.238	1.0	3240.	.270	1.0		
375.	1.49	150.	375.	1.49	30.		

Figure B-2. Data for 50th-percentile standard dummy.

11.50	8.85	11.98	14.10	17.49	19.08		
4.95	6.94	6.71	5.00	6.64	8.85	11.62	
44.6	46.4	13.0	6.26	6.26	28.0	12.2	2.55
3.36	3.16	.399	.191	.025	.184	1.44	
1.10	1.34	.386	.196	.268	1.77	1.44	.026
3.36	2.47	.338	.032	.283	1.27	.732	
4.77	4.77	3.55	2.07	1.96	3.29	2.44	2.44
1.70	3.77	2.77	1.96	2.48			
3.92	6.72	0.21	0.21	2.12			
2000.	.050	2000.	.380				
6000.	.238	1.0	3240.	.270	1.0		
375.	1.49	150.	375.	1.49	30.		

Figure B-3. Data for 95th-percentile dummy.

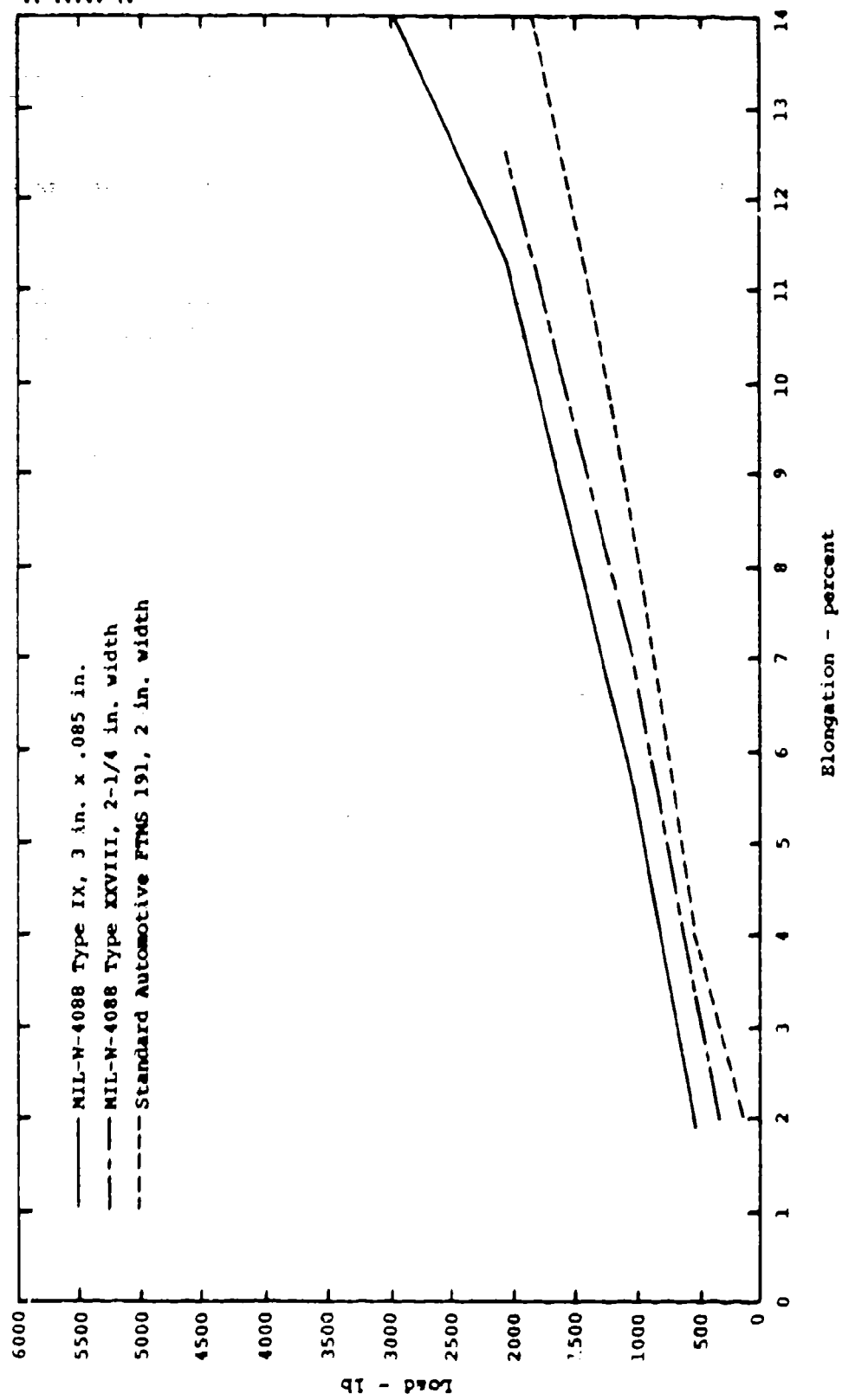

Figure B-4. Load-elongation characteristics for nylon webbing.

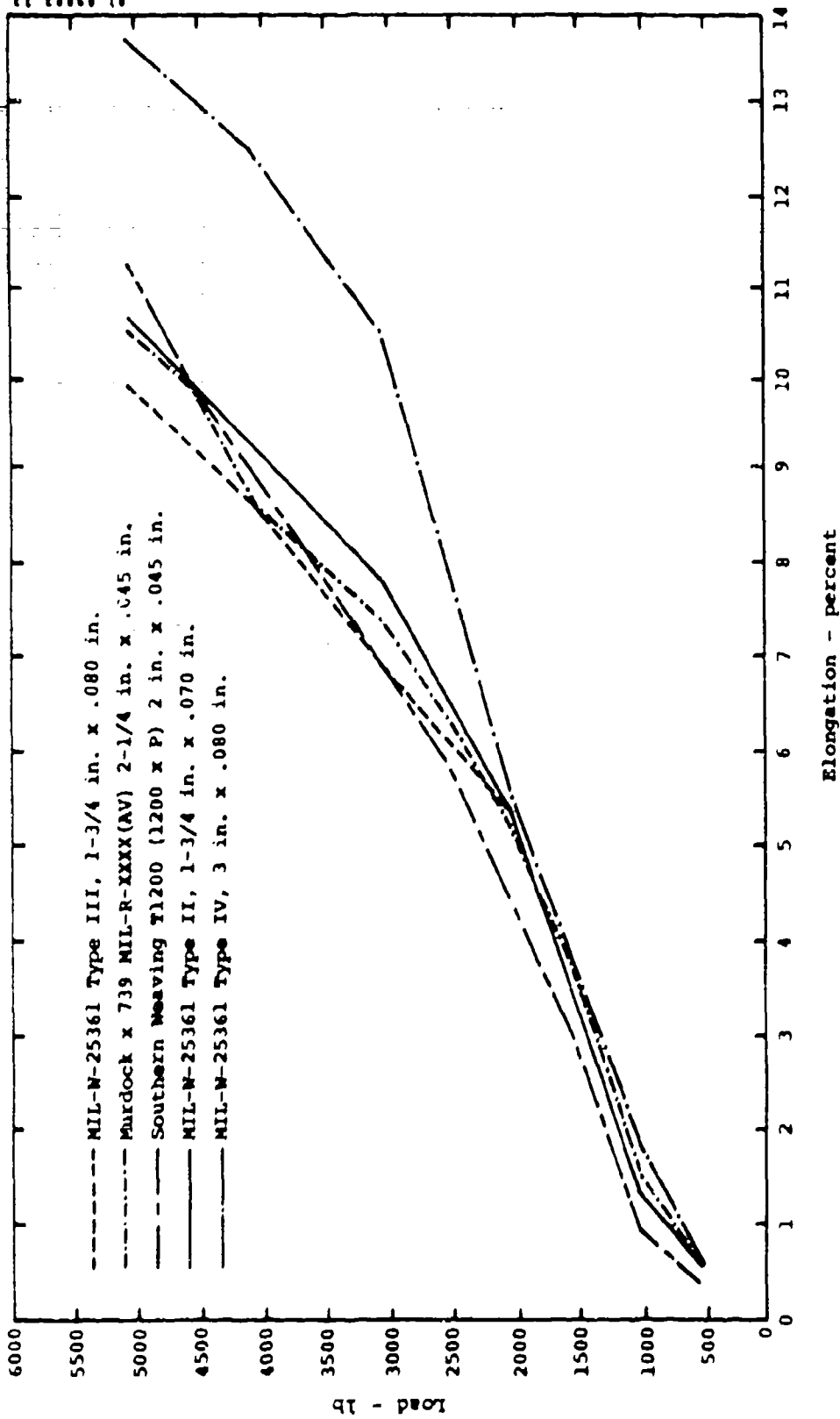

Figure B-5. Load-elongation characteristics for polyester webbing.

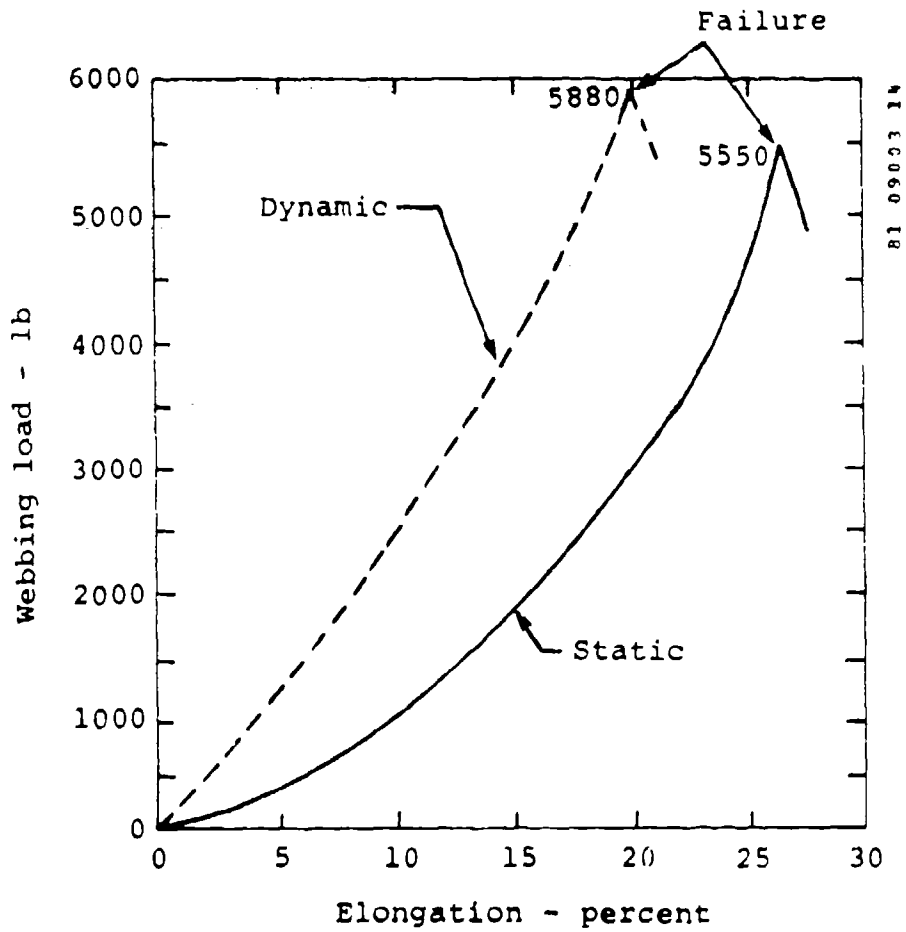

Figure B-6. Load-strain curves for MIL-W-4088 (Type VII) nylon webbing for static and rapid loading rates (from reference B-1).

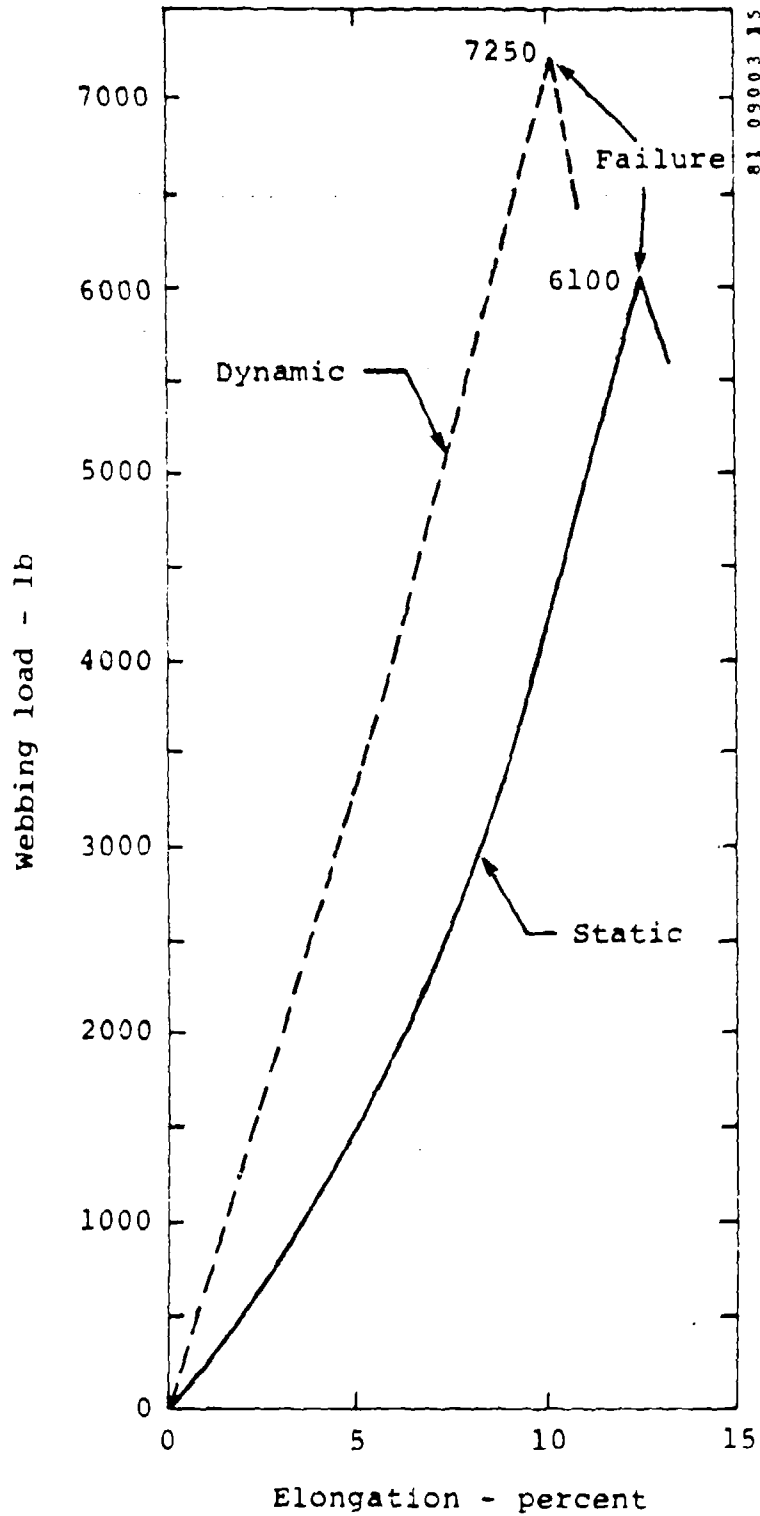

Figure B-7. Load-strain curves for ML-W-25361 (Type II) polyester webbing for static and rapid loading rates (from reference B-1).

K (lb/in.in.)

C (lb-sec/in./in.)

82 09003 46

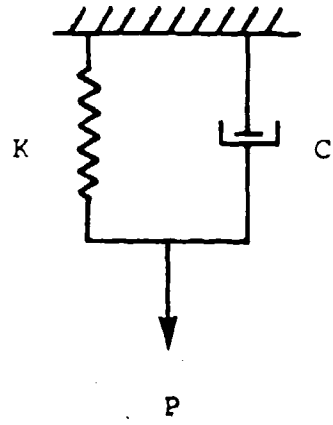

Figure B-8. Voigt-Kelvin model of restraint system webbing.

81 09003 42

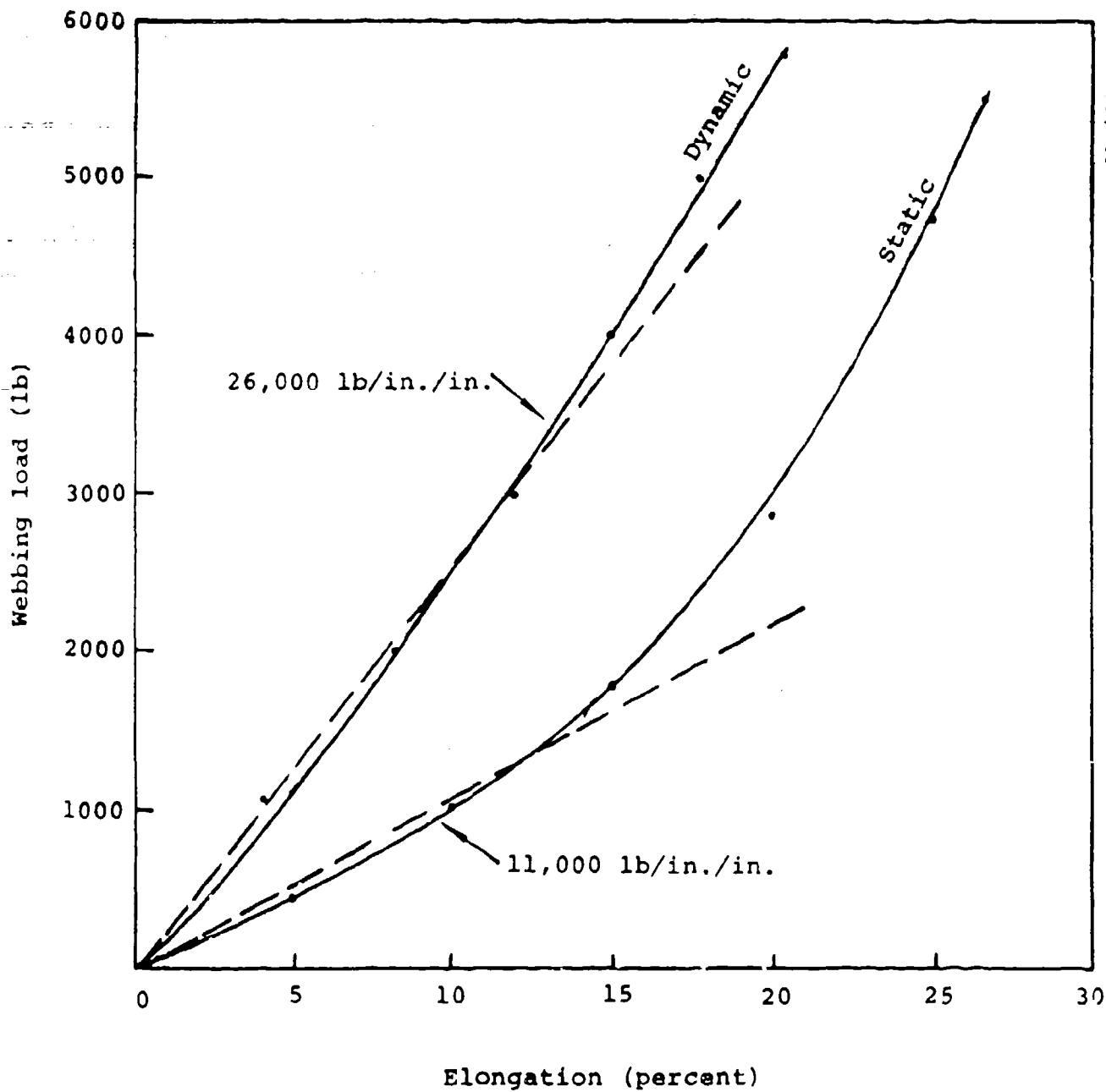

Figure B-9. Stress-strain curves for MIL-W-4088 (Type VII) nylon webbing for static and rapid loading rates with linear approximations.

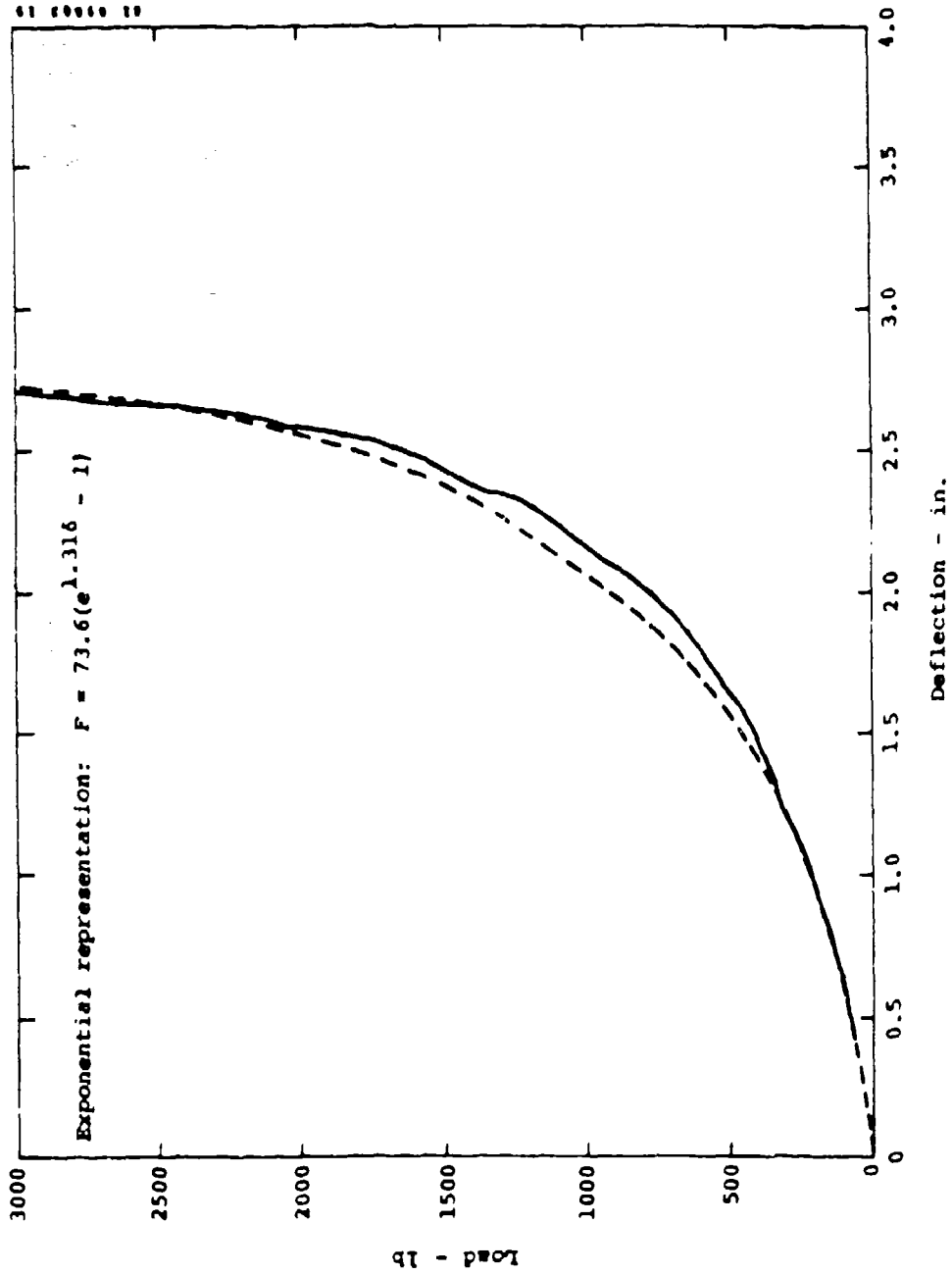

Figure B-10. Combined load-deflection curve and exponential representation for Type 1 cushion and VIP-95 dummy pelvis and buttocks.

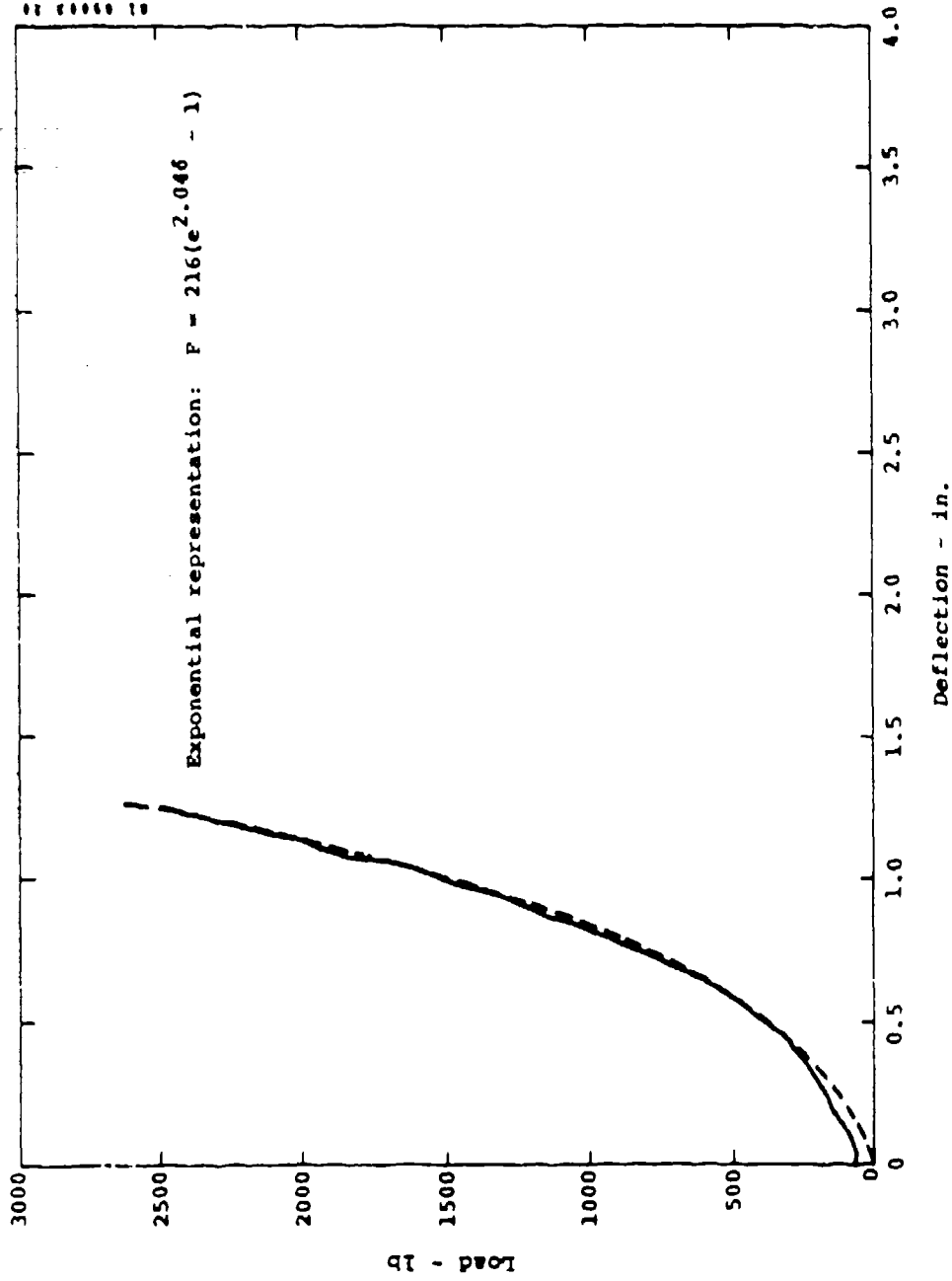

Figure B-11. Combined load-deflection curve and exponential representation for Type 2 cushion and VIP-95 dummy pelvis and buttocks.

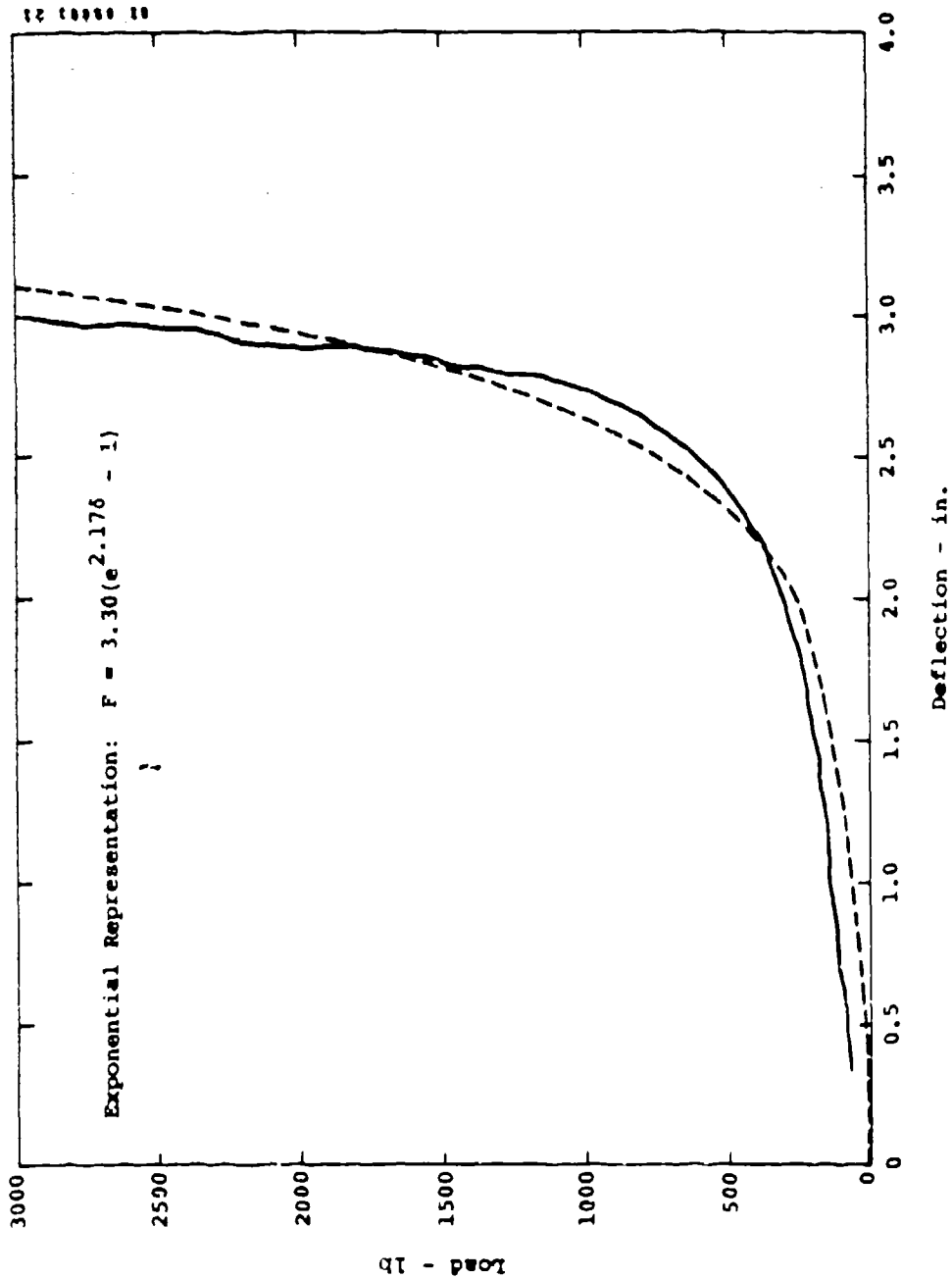

Figure B-12. Combined load-deflection curve and exponential representation for Type 3 cushion and VIP-95 dummy pelvis and buttocks.

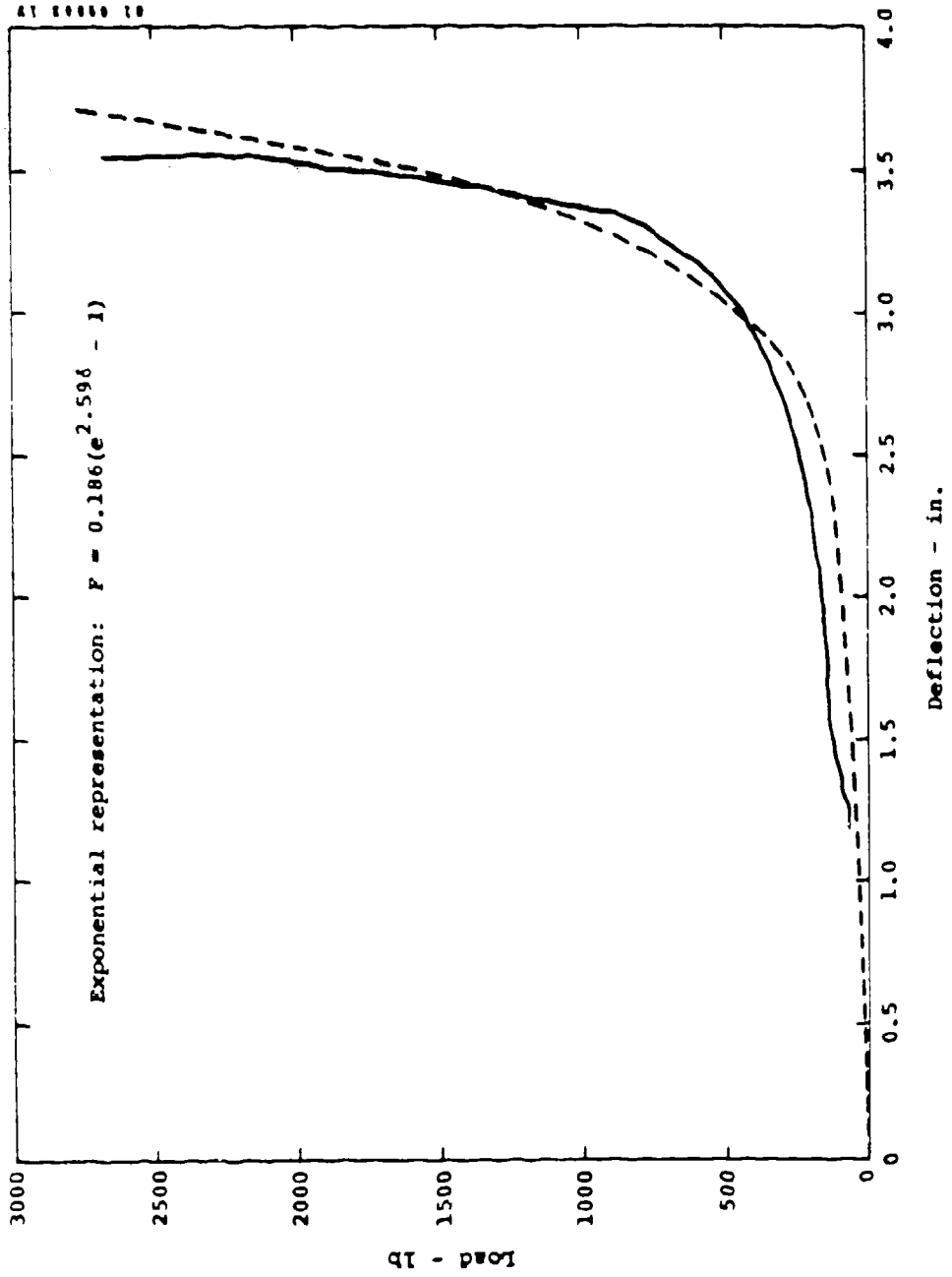

Figure B-13. Combined load-deflection curve and exponential representation for Type 4 cushion and VIP-95 dummy pelvis and buttocks.

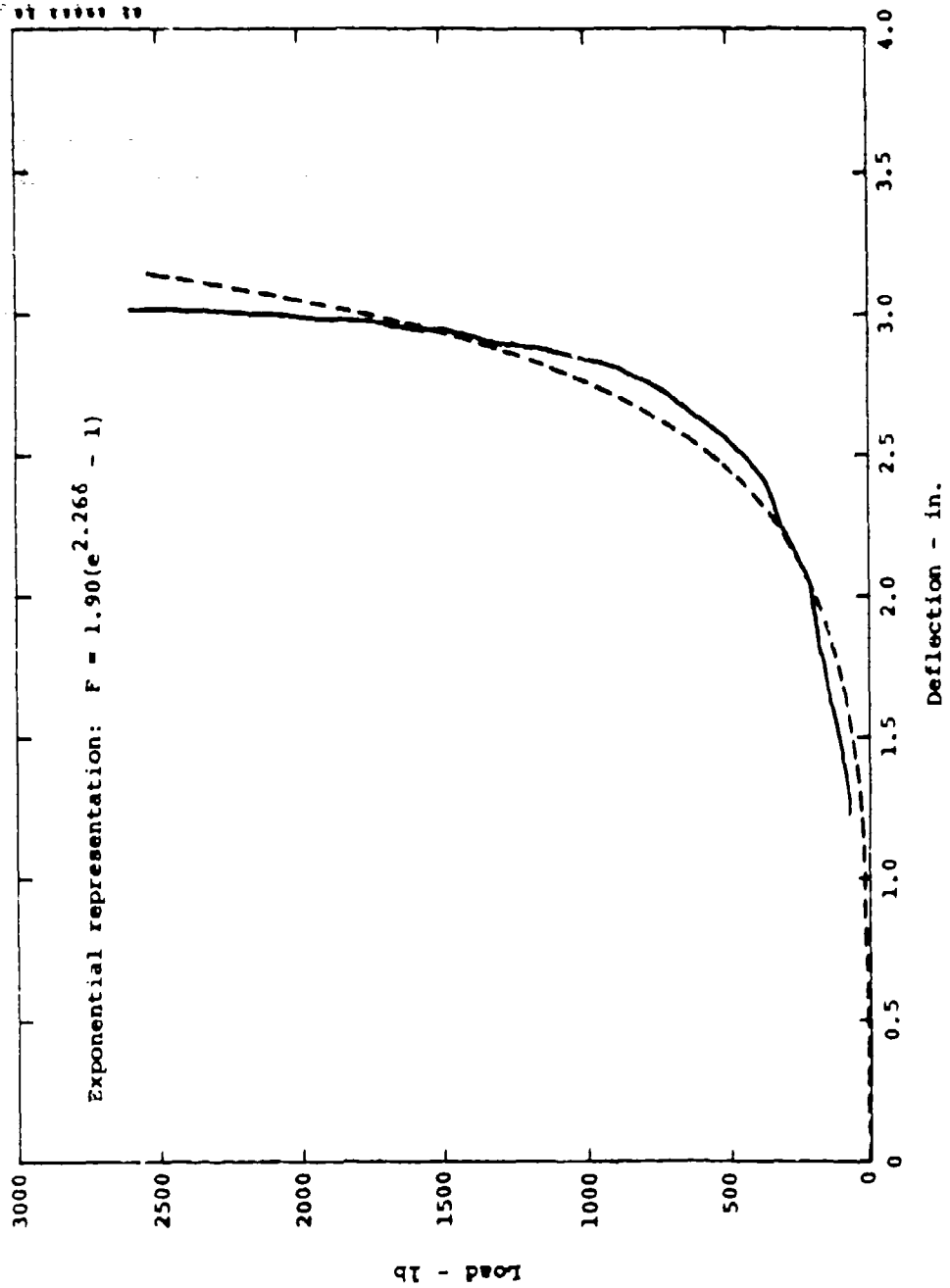

Figure B-14. Combined load-deflection curve and exponential representation for Type 5 cushion and VIP-95 dummy pelvis and buttocks.

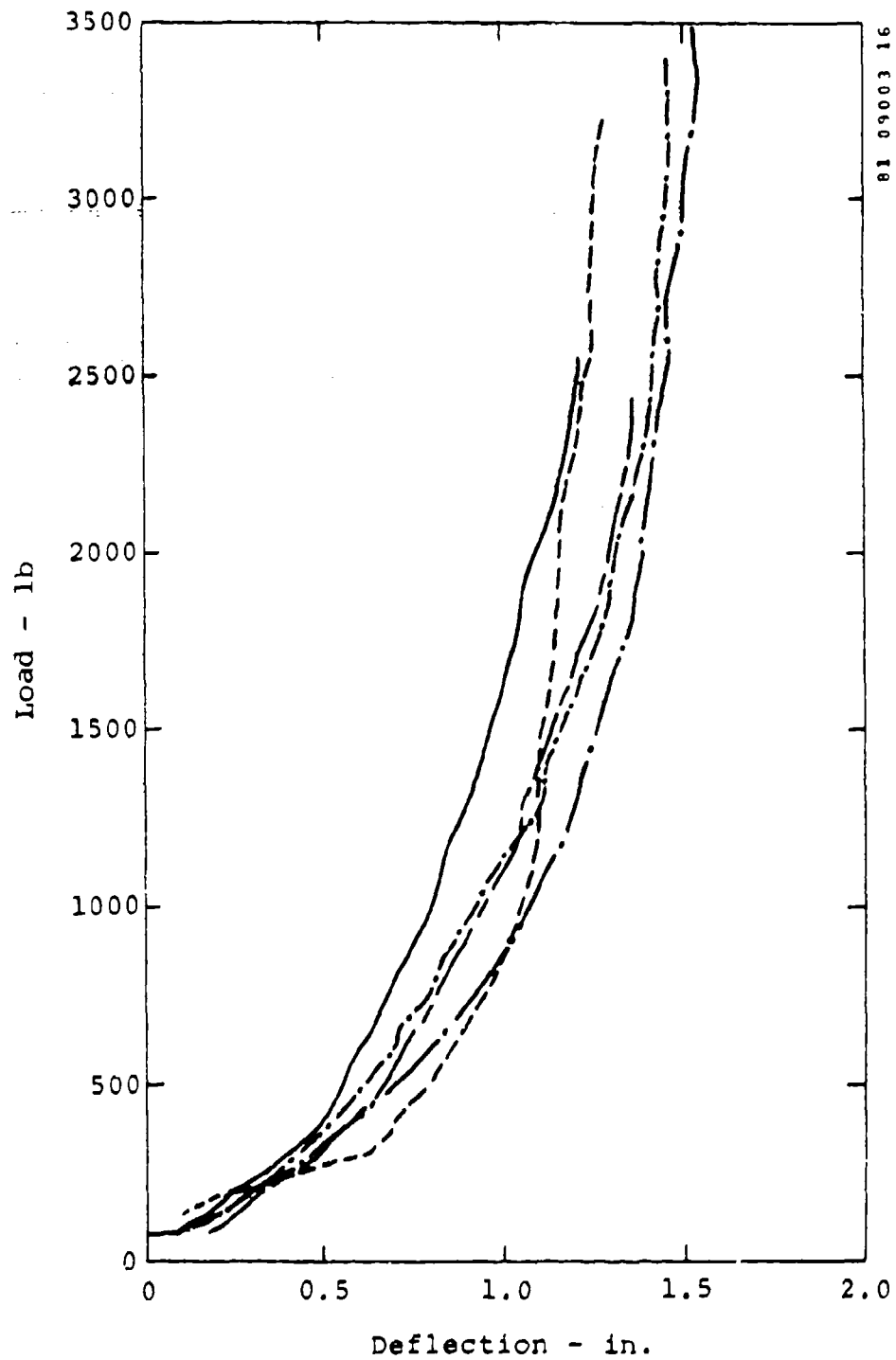

Figure B-15. Load-deflection curves for Alderson VIP-95 dummy pelvis and buttocks tested with five different cushions.

Approximate Material Properties

Modulus of elasticity, $E(2) = 30 \times 10^6$ psi
First yield stress, $E(3) = 58,700$ psi
First plastic modulus, $E(4) = 2.9 \times 10^5$ psi
Ultimate stress, $E(6) = 67,000$ psi
Second yield stress, $E(11) = 62,500$ psi
Second plastic modulus, $E(12) = 75,000$ psi

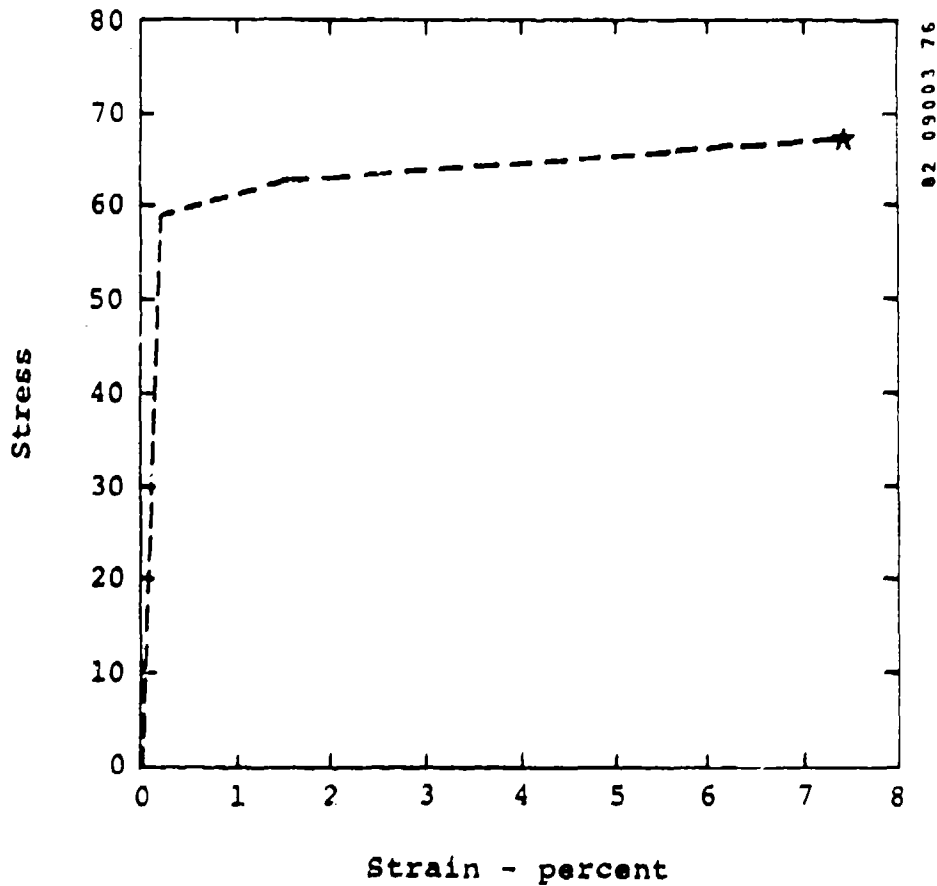
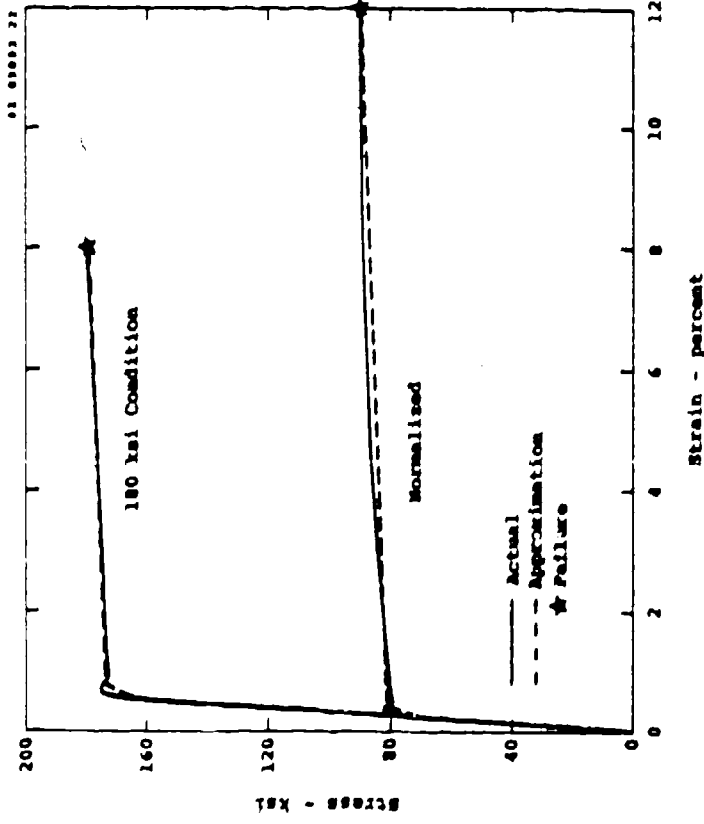

Figure B-16. Piecewise, linear approximation of stress-strain curve for 1010 cold-drawn steel.



Approximated Material Properties
 Modulus of elasticity, $E(2) = 29.0 \times 10^6$ psi
 First yield stress, $E(3) = 163,000$ psi
 First plastic modulus, $E(4) = 6.0 \times 10^5$ psi
 Ultimate stress, $E(6) = 180,000$ psi
 Second yield stress, $E(11) = 174,000$ psi
 Second Plastic modulus, $E(12) = 8.1 \times 10^4$ psi

Approximated Material Properties For Normalized State
 Modulus of Elasticity, $E(2) = 29.0 \times 10^6$ psi
 First yield stress, $E(3) = 70,000$ psi
 First plastic modulus, $E(4) = 7.0 \times 10^5$ psi
 Ultimate stress, $E(6) = 90,000$ psi
 Second yield stress, $E(11) = 80,000$ psi
 Second plastic modulus, $E(12) = 1.0 \times 10^5$ psi

Figure B-17. Typical tensile stress-strain curves for AISI 4130 steel heat treated to ksi and normalized state; and piecewise, linear approximation to curves.

Approximated Material Properties

Modulus of elasticity, $E(2) = 29.1 \times 10^6$ psi

First yield stress, $E(3) = 160,000$ psi

First plastic modulus, $E(4) = 7.8 \times 10^6$ psi

Ultimate stress, $E(6) = 180,000$ psi

Second yield stress, $E(11) = 170,000$ psi

Second plastic modulus, $E(12) = 8.85 \times 10^5$ psi

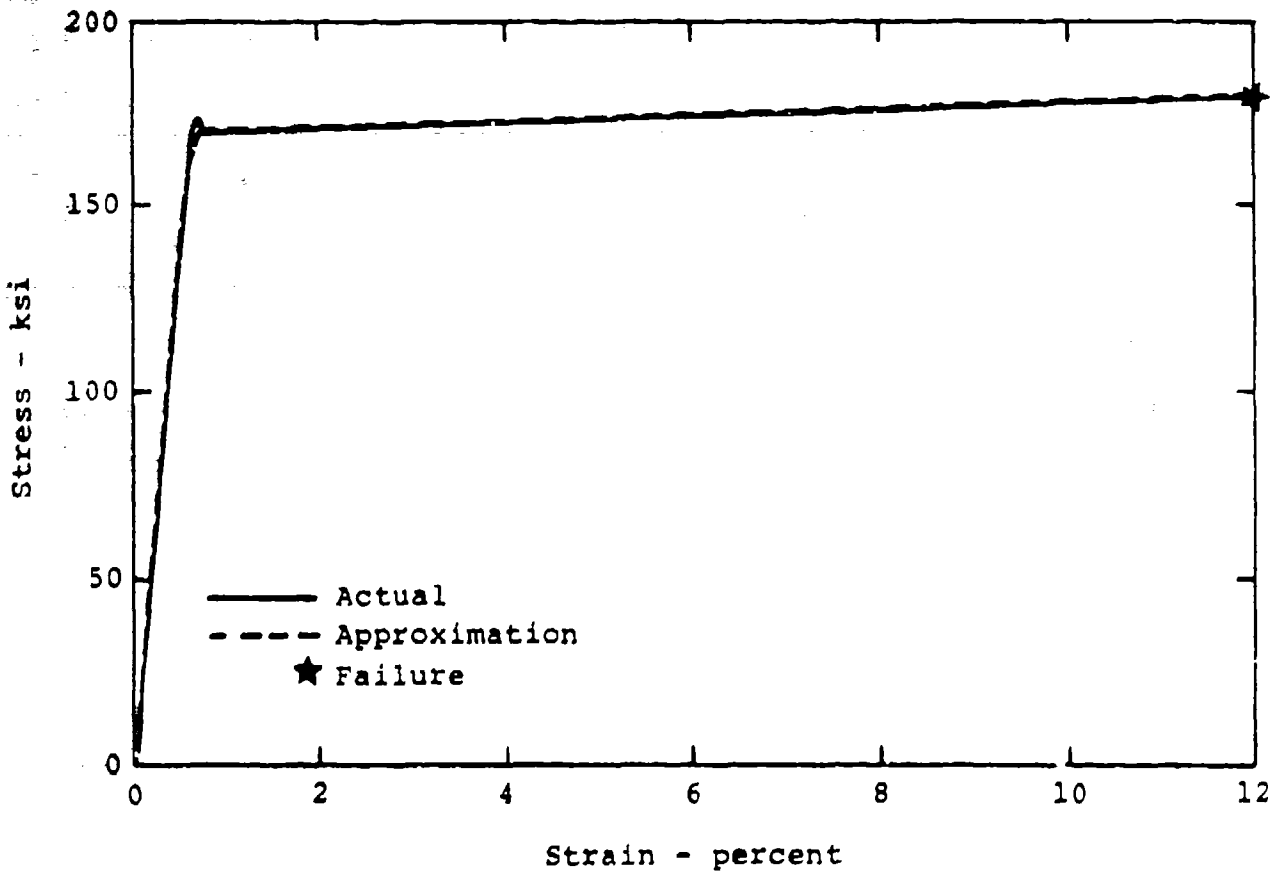

Figure B-18. Typical tensile stress-strain curve for AISI 4340 steel, heat treated to 180 ksi ultimate stress and piecewise, linear approximation to curve.

Approximated Material Properties

Modulus of elasticity, $E(2) = 10.5 \times 10^6$ psi

First yield stress, $E(3) = 44,000$ psi

First plastic modulus, $E(4) = 4.9 \times 10^5$ psi

Ultimate stress, $E(6) = 62,000$ psi

Second yield stress, $E(11) = 58,000$ psi

Second plastic modulus, $E(12) = 6.2 \times 10^4$ psi

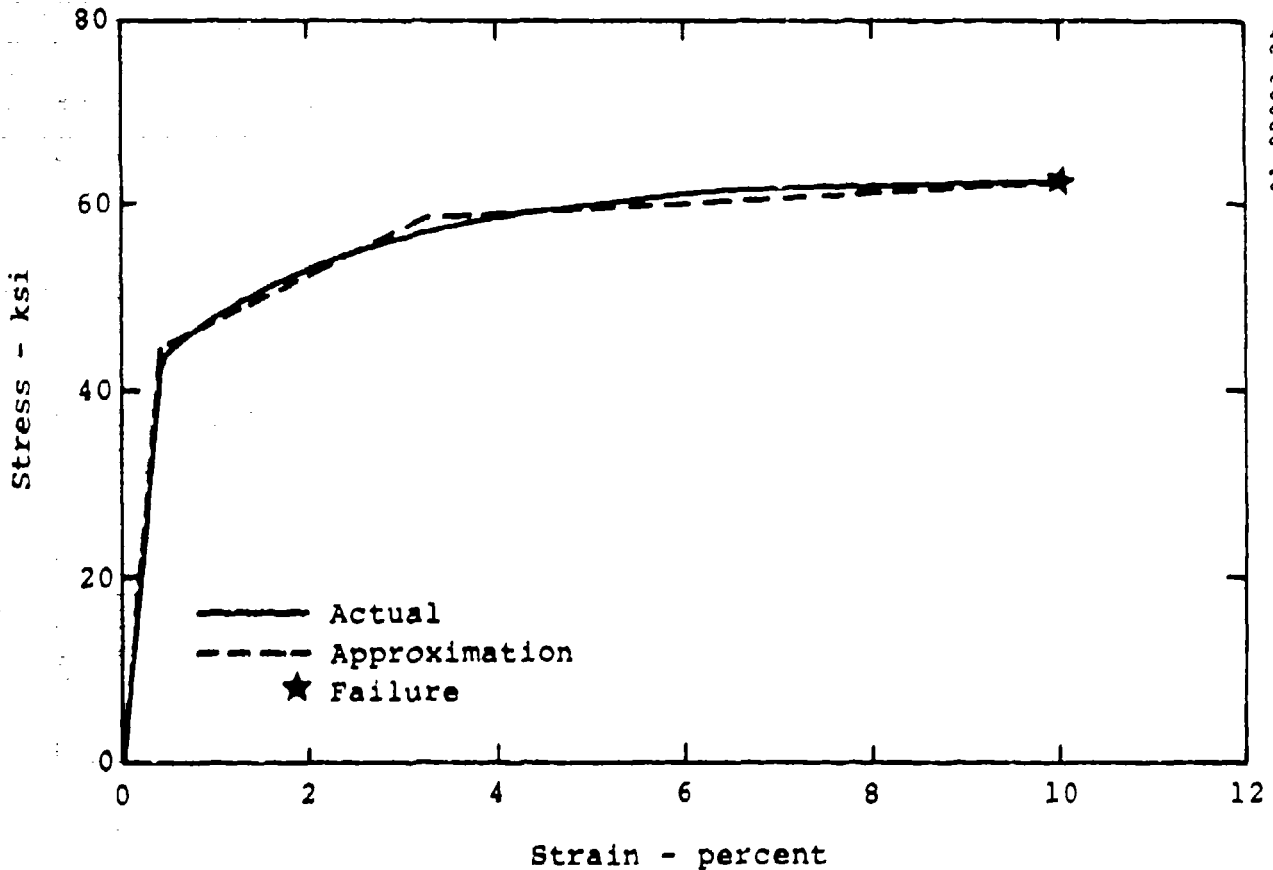

Figure B-19. Typical tensile stress-strain curve for 2024-T4 aluminum alloy and piecewise, linear approximation to curve.

Approximated Material Properties

Modulus of elasticity, $E(2) = 9.9 \times 10^6$ psi

First yield stress, $E(3) = 36,200$ psi

First plastic modulus, $E(4) = 1.1 \times 10^5$ psi

Ultimate stress, $E(6) = 42,000$ psi

Second yield stress, $E(11) = 40,200$ psi

Second plastic modulus, $E(12) = 3.0 \times 10^4$ psi

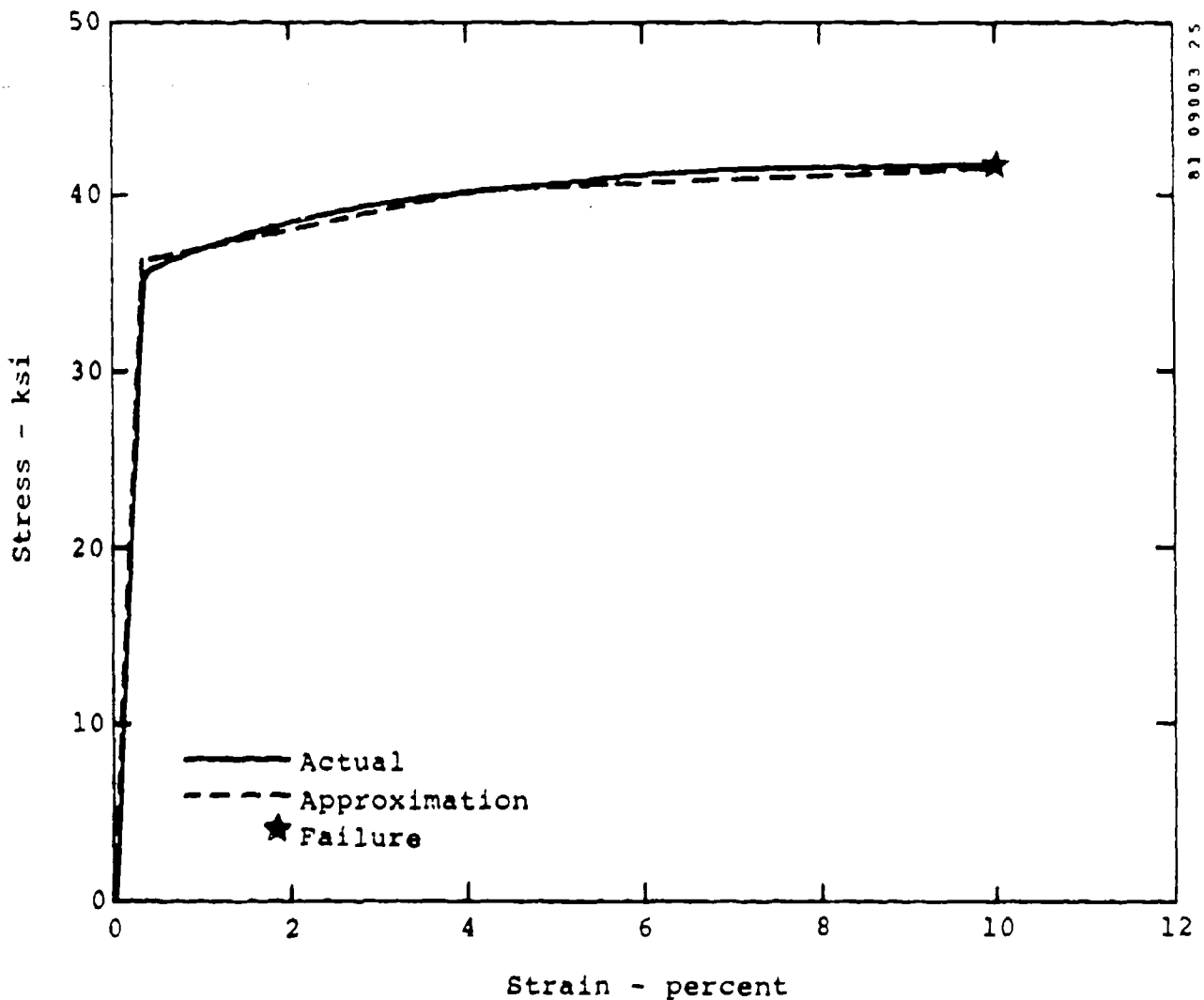

Figure B-20. Typical tensile stress-strain curve for 6061-T6 aluminum, alloy and piecewise, linear approximation to curve.

APPENDIX C

OUTPUT OF PROGRAM SOM-LA
FOR EXAMPLE CASE NO. 1

NOTE: In order to reduce the size of this report, the output listing presented in this Appendix was printed with some carriage controls suppressed. Also, only the first two sets and the last set of seat structure output were copied for inclusion in the report.

CAHI SERIES 2 - LOW DECELERATION
INPUT DATA

A 2-DIMENSIONAL SIMULATION HAS BEEN REQUESTED

SIMULATION CONTROL DATA

TI=0.000000, TF = .300000, DTI = .000500, DMAX = .000500, DMIN = .000500
EUR = .100000, ELR = .001000

ACCELERATION FILTER CLASSES

HEAD	CHEST	PELVIS	SEAT
1000	180	180	180

FORCE-DEFLECTION CHARACTERISTICS

SEAT CUSHION		BACK CUSHION		HEAD REST	
C	B	C	B	C	B
375.000	.653	375.000	.653	0.000	0.000
F2	D2	F3	D3	F4	D4
LAP BELT					
550.00	.04030	1300.00	.10480	2250.00	.18130
SHOULDER HARNESS					
550.00	.04030	1300.00	.10480	2250.00	.18130
XLB(1)	YLB(1)	ZLB(1)	XLB(2)	YLB(2)	ZLB(2)
.750	-8.000	13.630	.750	8.000	13.630
XBH	YBH	ZBH			
0.000	0.000	41.380			

DAMPING COEFFICIENT THICKNESS/SLACK

SEAT CUSHION		
	.85000	3.00000
BACK CUSHION		
	.85000	3.00000
LAP BELT		
	0.00000	0.00000
SHOULDER HARNESS		
	0.00000	0.00000

CRASH CONDITIONS

X	Y	Z	PITCH	ROLL	YAW
0.00000	0.00000	0.00000	0.00000	0.00000	0.00000
VX	UY	VZ	ANGVX	ANGUY	ANGVZ
44.18000	0.00000	0.00000	0.00000	0.00000	0.00000
TX	AX	TY	AY	TZ	AZ
0.00000	0.00000	0.00000	0.00000	0.00000	0.00000
.00800	-.18000	0.00000	0.00000	0.00000	0.00000
.01800	-4.04000	0.00000	0.00000	0.00000	0.00000
.02500	-4.20000	0.00000	0.00000	0.00000	0.00000
.03100	-5.81000	0.00000	0.00000	0.00000	0.00000
.03800	-5.75000	0.00000	0.00000	0.00000	0.00000
.04000	-5.05000	0.00000	0.00000	0.00000	0.00000
.04800	-6.14000	0.00000	0.00000	0.00000	0.00000
.05700	-5.44000	0.00000	0.00000	0.00000	0.00000
.06500	-6.22000	0.00000	0.00000	0.00000	0.00000
.07200	-5.38000	0.00000	0.00000	0.00000	0.00000
.08000	-5.83000	0.00000	0.00000	0.00000	0.00000
.08400	-5.44000	0.00000	0.00000	0.00000	0.00000
.28300	-5.44000	0.00000	0.00000	0.00000	0.00000
.28300	1.32000	0.00000	0.00000	0.00000	0.00000
.31400	0.00000	0.00000	0.00000	0.00000	0.00000
TX	ALFX	TY	ALFY	TZ	ALFZ
0.00000	0.00000	0.00000	0.00000	0.00000	0.00000
0.00000	0.00000	0.00000	0.00000	0.00000	0.00000
0.00000	0.00000	0.00000	0.00000	0.00000	0.00000
0.00000	0.00000	0.00000	0.00000	0.00000	0.00000
0.00000	0.00000	0.00000	0.00000	0.00000	0.00000
0.00000	0.00000	0.00000	0.00000	0.00000	0.00000
0.00000	0.00000	0.00000	0.00000	0.00000	0.00000
0.00000	0.00000	0.00000	0.00000	0.00000	0.00000
0.00000	0.00000	0.00000	0.00000	0.00000	0.00000
0.00000	0.00000	0.00000	0.00000	0.00000	0.00000
0.00000	0.00000	0.00000	0.00000	0.00000	0.00000
0.00000	0.00000	0.00000	0.00000	0.00000	0.00000
0.00000	0.00000	0.00000	0.00000	0.00000	0.00000
0.00000	0.00000	0.00000	0.00000	0.00000	0.00000
0.00000	0.00000	0.00000	0.00000	0.00000	0.00000
0.00000	0.00000	0.00000	0.00000	0.00000	0.00000
0.00000	0.00000	0.00000	0.00000	0.00000	0.00000
0.00000	0.00000	0.00000	0.00000	0.00000	0.00000
0.00000	0.00000	0.00000	0.00000	0.00000	0.00000
0.00000	0.00000	0.00000	0.00000	0.00000	0.00000
0.00000	0.00000	0.00000	0.00000	0.00000	0.00000
0.00000	0.00000	0.00000	0.00000	0.00000	0.00000

SEAT DESIGN DATA

XBEAT= 0.0000 ZBEAT= 12.7500 ANGBP= 0.0000 ANGBB= 0.0000
XL = 18.0000 XM = 18.0000 SBHT = 40.8800 SB = 18.0000

NUMBER OF NODES 18
NUMBER OF ELEMENTS 21
NUMBER OF MATERIALS 1
NO. OF DISP. NODES 4
NO. OF COORD NODES 2
NO. OF BEAM XBECT 3
BUCKLING CONSTANT .50

MATERIAL DATA

MATERIAL NAME 1010 STEEL
MATERIAL NO 1
FIRST YIELD STRESS .58700E+05
SECOND YIELD STRESS .62500E+05
ULTIMATE STRESS .67000E+05
MODULUS OF ELASTICITY .30000E+08
FIRST PLASTIC MODULUS .28000E+08
SECOND PLASTIC MODULUS .75000E+05
POISSONS RATIO (PLATES ONLY) .30000E+00
THICKNESS (PLATES ONLY) .10000E+00

BEAM CROSS-SECTION DATA

N	NSEG	KLOS	AM1	FIXX	FIYY	FIZZ	TORCON
1	8	0	.18530E+00	.43900E-01	.21900E-01	.21900E-01	.16344E-02

I	Y	Z	XLEN	T
1	-.47E+00	0.	.38E+00	.68E-01
2	-.33E+00	-.33E+00	.38E+00	.68E-01
3	0.	-.47E+00	.38E+00	.68E-01
4	.33E+00	-.33E+00	.38E+00	.68E-01
5	.47E+00	0.	.38E+00	.68E-01
6	.33E+00	.33E+00	.38E+00	.68E-01
7	0.	.47E+00	.38E+00	.68E-01
8	-.33E+00	.33E+00	.38E+00	.68E-01

N	NSEG	KLOS	AM1	FIXX	FIYY	FIZZ	TORCON
2	4	0	.48144E+00	.32300E+00	.24300E+00	.80000E-01	.14785E+00

I	Y	Z	XLEN	T
1	-.88E+00	-.48E+00	.82E+00	.85E-01
2	-.88E+00	.48E+00	.18E+01	.85E-01
3	.88E+00	.48E+00	.82E+00	.85E-01
4	.88E+00	-.48E+00	.18E+01	.85E-01

N	NSEG	KLOS	AM1	FIXX	FIYY	FIZZ	TORCON
3	4	0	.31144E+00	.48800E-01	.24900E-01	.24900E-01	.48778E-01

I	Y	Z	XLEN	T
1	-.48E+00	-.48E+00	.82E+00	.85E-01
2	-.48E+00	.48E+00	.82E+00	.85E-01
3	.48E+00	.48E+00	.82E+00	.85E-01
4	.48E+00	-.48E+00	.82E+00	.85E-01

NODE NO.	X	Y	Z
1	0.00000	-8.00000	0.00000
2	18.00000	-8.00000	0.00000
3	18.00000	8.00000	0.00000
4	0.00000	8.00000	0.00000
5	0.00000	-8.00000	8.75000
8	18.00000	-8.00000	8.75000
7	18.00000	8.00000	8.75000
8	0.00000	8.00000	8.75000
9	0.00000	-8.00000	11.75000
10	18.00000	-8.00000	11.75000
11	18.00000	8.00000	11.75000
12	0.00000	8.00000	11.75000
13	0.00000	-8.00000	12.75000
14	18.00000	-8.00000	12.75000
15	18.00000	8.00000	12.75000
16	0.00000	8.00000	12.75000
17	0.00000	-8.00000	41.38000
18	0.00000	8.00000	41.38000
19	0.00000	22.00000	0.00000
20	18.00000	22.00000	0.00000

ELEMENT NO.	N1	N2	N3	N4	N5	N6	N7	N8	HTYP
1	1	5	1	5	0	1	4	2	1
2	5	9	5	9	0	1	4	2	1
3	9	13	9	13	0	1	4	2	1
4	2	8	2	8	0	1	3	2	1
5	8	10	8	10	0	1	3	2	1
6	10	14	10	14	0	1	3	2	1
7	3	7	3	7	0	1	20	2	1
8	7	11	7	11	0	1	20	2	1
9	11	15	11	15	0	1	20	2	1
10	4	8	4	8	0	1	19	2	1
11	8	12	8	12	0	1	19	2	1
12	12	16	12	16	0	1	19	2	1
13	13	14	13	14	0	2	1	2	1
14	14	15	14	15	0	2	2	2	1
15	15	18	15	18	0	2	3	2	1
16	18	13	18	13	0	2	4	2	1
17	13	17	13	17	0	2	14	2	1
18	14	17	14	17	0	3	15	2	1
19	15	18	15	18	0	3	14	2	1
20	16	18	16	18	0	2	15	2	1
21	18	17	18	17	0	2	16	2	1

SEAT PAN NODES = 13 16 14 15

SEAT BACK NODES = 13 16 17 18

LAP BELT ANCHOR NODES = 13 18

SHOULDER HARNESS ANCHOR NODES = 17 18

DISPLACEMENT NODES

NODE	CONDITION
1	1 1 1 1 0 1
2	2 1 1 1 1 0 1
3	3 1 1 1 1 0 1
4	4 1 1 1 1 0 1

OCCUPANT PROPERTIES

STATURE= 69.10 INCHES, WEIGHT= 184.38 POUNDS

SEGMENT	LENGTH	RHO	MASS	IX	IY	IZ
1	10.783	4.870	.088545	2.320000	.780000	2.320000
2	11.580	8.330	.083080	2.180000	.830000	1.700000
3	8.350	8.330	.028138	.275000	.288000	.233000
4	11.300	4.720	.012552	.132000	.135000	.022000
5	13.300	8.280	.012552	.017000	.185000	.185000
6	11.300	4.720	.012552	.132000	.135000	.022000
7	13.300	8.280	.012552	.017000	.185000	.185000
8	18.500	8.330	.058158	.127000	1.220000	.873000
9	18.000	10.980	.024580	.827000	.884000	.505000
10	18.500	8.330	.058158	.127000	1.220000	.873000
11	18.000	10.980	.024580	.827000	.884000	.505000
12	5.100	0.000	.005124		.017700	

CONTACT SURFACE RADII

SEGMENT	RADIUS
1	4.50
2	4.50
3	3.44
4	1.85
5	1.85
6	1.85
7	1.85
8	3.10
9	2.30
10	3.10
11	2.30
12	2.30
13	2.30
14	1.80
15	1.80
16	3.58
17	3.58
18	2.61
19	2.61
20	1.85
21	1.85
22	2.34
23	2.34

SPINAL PROPERTIES

	COEFFICIENT C	EXP COEFF B	DAMPING
LUMBAR SPINE - AXIAL	8000.000	.238	1.000
LUMBAR SPINE - FLEXURAL	375.000	1.480	150.000
NECK - AXIAL	3240.000	.270	1.000
NECK - FLEXURAL	375.000	1.480	30.000

INITIAL CONDITIONS

SEGMENT	ANGLE
1	0.000
2	0.000
3	23.000
4	-17.000
5	80.000
6	-17.000
7	80.000
8	.981
9	-6.387
10	.981
11	-6.387

GENERALIZED COORDINATES

J	G(J)	GD(J)	GDD(J)
1	.75000E+01	.53018E+03	0.
2	.24435E+02	0.	0.
3	0.	0.	0.
4	.10850E+02	0.	0.
5	0.	0.	0.
6	.63300E+01	0.	0.
7	.40143E+00	0.	0.
8	-.28671E+00	0.	0.
9	.22889E+00	0.	0.
10	.16784E-01	0.	0.
11	-.11147E+00	0.	0.

STRESS AND BAR STORAGE LSTRB 1058 LBAR 504

MUD 28 SIZE OF STIFF 2805

NODAL DISPLACEMENT VECTOR (TIME = .005 SEC)

NODE NO	TRANSLATION		
	X	Y	Z
1	0.	0.	0.
2	0.	0.	0.
3	0.	0.	0.
4	0.	0.	0.
5	.547517E-03	.287728E-07	-.668141E-04
6	.543287E-03	.145782E-08	-.488780E-04
7	.543287E-03	-.145782E-08	-.488780E-04
8	.547517E-03	-.287728E-07	-.668141E-04
9	.583454E-03	.303870E-07	-.802785E-04
10	.581538E-03	.112270E-08	-.588885E-04
11	.581538E-03	-.112270E-08	-.588885E-04
12	.583454E-03	-.303871E-07	-.802785E-04
13	.802812E-03	.307421E-07	-.871107E-04
14	.802812E-03	.736582E-10	-.848848E-04
15	.802812E-03	-.736582E-10	-.848848E-04
16	.802812E-03	-.307421E-07	-.871107E-04

SUPPORT STRUCTURE REACTIONS (TIME = .005 SEC)

NODE NO	FORCES			MOMENTS		
	FX	FY	FZ	MX	MY	MZ
1	-.517174E+00	-.121578E-03	.387028E+02	.785188E-03	-.284217E-13	.184851E-0
2	-.482378E+00	-.141841E-05	.288577E+02	.882788E-05	-.113887E-12	.189483E-0
3	-.482378E+00	.141838E-05	.288577E+02	-.882778E-05	-.284217E-13	-.189483E-0
4	-.517174E+00	.121578E-03	.387028E+02	-.785188E-03	-.142108E-12	-.184851E-0

STRESSES IN BEAM ELEMENTS (TIME = .005 SEC)

BEAM NO	NODE NO	S	
		MAX	MIN
1	1	0.	-.204835E+03
	5	0.	-.312380E+03
2	5	0.	-.312380E+03
	8	0.	-.334442E+03
3	8	0.	-.334438E+03
	13	0.	-.345488E+03
4	2	0.	-.152814E+03
	6	0.	-.255102E+03
5	8	0.	-.255132E+03
	10	0.	-.278125E+03
6	10	0.	-.278121E+03
	14	0.	-.286822E+03

NODAL DISPLACEMENT VECTOR (TIME = .010 SEC)

NODE NO	TRANSLATION		
	X	Y	Z
1	0.	0.	0.
2	0.	0.	0.
3	0.	0.	0.
4	0.	0.	0.
5	.877351E-03	.108108E-08	-.858785E-04
6	.870584E-03	.584027E-08	-.503148E-04
7	.870584E-03	-.584021E-08	-.503148E-04
8	.877351E-03	-.108108E-08	-.858785E-04
9	.851817E-03	.123758E-08	-.785128E-04
10	.848807E-03	.457336E-08	-.806353E-04
11	.848807E-03	-.457328E-08	-.806353E-04
12	.851817E-03	-.123758E-08	-.785128E-04
13	.867784E-03	.125285E-08	-.862788E-04
14	.867524E-03	.300181E-08	-.857880E-04
15	.867524E-03	-.300174E-08	-.857880E-04
16	.867784E-03	-.125285E-08	-.862788E-04

SUPPORT STRUCTURE REACTIONS (TIME = .010 SEC)

NODE NO	FORCES			MOMENTS		
	FX	FY	FZ	MX	MY	MZ
1	-.808488E+00	-.485474E-03	.384442E+02	.311845E-02	.142109E-12	.752514E-05
2	-.770580E+00	-.578455E-05	.281880E+02	.270107E-04	.852851E-13	.772208E-05
3	-.770580E+00	.578453E-05	.281880E+02	-.270108E-04	-.852851E-13	-.772208E-05
4	-.808488E+00	.485474E-03	.384442E+02	-.311845E-02	.188852E-12	-.752514E-05

STRESSES IN BEAM ELEMENTS (TIME = .010 SEC)

BEAM NO	NODE NO	STRESS	
		S-MAX	S-MIN
1	1	0.	-.202898E+03
	5	0.	-.373507E+03
2	5	0.	-.373592E+03
	9	.263084E+01	-.408811E+03
3	9	.258428E+01	-.408808E+03
	13	.201110E+02	-.428125E+03
4	2	0.	-.154888E+03
	6	.771858E+01	-.317105E+03
5	6	.780752E+01	-.317180E+03
	10	.408387E+02	-.350521E+03
6	10	.408044E+02	-.350522E+03
	14	.575778E+02	-.367185E+03

NODAL DISPLACEMENT VECTOR (TIME = .280 SEC)

NODE NO	TRANSLATION		
	X	Y	Z
1	0.	0.	0.
2	0.	0.	0.
3	0.	0.	0.
4	0.	0.	0.
5	.188582E+01	.817100E-04	-.138581E+00
6	.188100E+01	.423018E-08	-.147508E+00
7	.188100E+01	-.423018E-08	-.147508E+00
8	.188582E+01	-.817100E-04	-.138581E+00
9	.180210E+01	.708215E-04	-.147442E+00
10	.180223E+01	-.232853E-08	-.182255E+00
11	.180223E+01	-.232853E-08	-.182255E+00
12	.180210E+01	-.708215E-04	-.147442E+00
13	.184233E+01	.717511E-04	-.147182E+00
14	.184247E+01	.127038E-08	-.184740E+00
15	.184247E+01	-.127038E-08	-.184740E+00
16	.184233E+01	-.717511E-04	-.147182E+00

SUPPORT STRUCTURE REACTIONS (TIME = .280 SEC)

NODE NO	FORCES			MOMENTS		
	FX	FY	FZ	MX	MY	MZ
1	-.335438E+03	-.150882E+00	-.858204E+03	.103483E+01	.580320E-08	-.183135E+00
2	-.883108E+02	-.883518E-02	.788622E+03	.377850E-01	-.529143E-08	-.388385E-02
3	-.883108E+02	.883514E-02	.788622E+03	-.377848E-01	-.239128E-08	.388383E-02
4	-.335438E+03	.150882E+00	-.858204E+03	-.103483E+01	.832004E-11	.183135E+00

STRESSES IN BEAM ELEMENTS (TIME = .280 SEC)

BEAM NO	NODE NO	S	
		S-MAX	S-MIN
1	1	.402423E+05	0.
	5	.800732E+05	-.588478E+05
2	5	.810858E+05	-.588781E+05
	9	.830038E+05	-.827148E+05
3	9	.838283E+05	-.834681E+05
	13	.841415E+05	-.838813E+05
4	2	.238878E+05	-.221412E+05
	6	.800385E+05	-.800217E+05
5	6	.588877E+05	-.808147E+05
	10	.827218E+05	-.828875E+05
6	10	.832543E+05	-.835055E+05
	14	.838890E+05	-.841402E+05

OCCUPANT SEGMENT POSITION
(IN AIRCRAFT REFERENCE FRAME)

TIME (SEC)	PELVIS			CHEST		
	X (IN)	Y (IN)	Z (IN)	X (IN)	Y (IN)	Z (IN)
0.000	7.50	0.00	24.43	7.50	0.00	35.28
.008	7.50	0.00	24.44	7.51	0.00	35.28
.012	7.51	0.00	24.48	7.53	0.00	35.28
.018	7.54	0.00	24.47	7.57	0.00	35.25
.025	7.61	0.00	24.48	7.65	0.00	35.25
.030	7.74	0.00	24.48	7.78	0.00	35.25
.036	7.84	0.00	24.48	7.86	0.00	35.25
.042	8.20	0.00	24.44	8.21	0.00	35.22
.048	8.51	0.00	24.40	8.49	0.00	35.15
.054	8.87	0.00	24.33	8.81	0.00	35.04
.060	8.28	0.00	24.22	8.15	0.00	34.88
.066	8.71	0.00	24.06	8.49	0.00	34.87
.072	10.17	0.00	23.84	8.81	0.00	34.41
.078	10.64	0.00	23.58	10.12	0.00	34.11
.084	11.11	0.00	23.28	10.51	0.00	33.77
.090	11.58	0.00	23.01	10.71	0.00	33.40
.096	12.04	0.00	22.78	11.00	0.00	33.08
.102	12.49	0.00	22.57	11.27	0.00	32.77
.108	12.81	0.00	22.43	11.53	0.00	32.58
.114	13.31	0.00	22.35	11.78	0.00	32.45
.120	13.67	0.00	22.34	11.88	0.00	32.44
.126	14.01	0.00	22.37	12.12	0.00	32.52
.132	14.32	0.00	22.48	12.28	0.00	32.84
.138	14.58	0.00	22.57	12.28	0.00	32.77
.144	14.84	0.00	22.68	12.35	0.00	32.81
.150	15.05	0.00	22.81	12.40	0.00	33.03
.156	15.24	0.00	22.80	12.44	0.00	33.12
.162	15.38	0.00	22.87	12.45	0.00	33.17
.168	15.52	0.00	22.88	12.45	0.00	33.17
.174	15.61	0.00	23.00	12.43	0.00	33.13
.180	15.68	0.00	22.88	12.38	0.00	33.07
.186	15.72	0.00	22.84	12.33	0.00	32.88
.182	15.74	0.00	22.89	12.28	0.00	32.80
.188	15.78	0.00	22.84	12.18	0.00	32.82
.204	15.77	0.00	22.80	12.10	0.00	32.78
.210	15.77	0.00	22.78	12.02	0.00	32.71
.216	15.77	0.00	22.78	11.85	0.00	32.68
.222	15.78	0.00	22.80	11.80	0.00	32.68
.228	15.78	0.00	22.84	11.85	0.00	32.72
.234	15.78	0.00	22.80	11.82	0.00	32.77
.240	15.78	0.00	22.88	11.78	0.00	32.85
.248	15.78	0.00	23.03	11.78	0.00	32.84
.252	15.77	0.00	23.10	11.78	0.00	33.03
.258	15.78	0.00	23.18	11.81	0.00	33.13
.264	15.74	0.00	23.24	11.84	0.00	33.21
.270	15.72	0.00	23.28	11.88	0.00	33.28
.276	15.68	0.00	23.32	11.88	0.00	33.35
.282	15.54	0.00	23.34	11.84	0.00	33.40
.288	15.33	0.00	23.33	11.72	0.00	33.42
.284	15.04	0.00	23.32	11.51	0.00	33.44

OCCUPANT SEGMENT POSITION
(IN AIRCRAFT REFERENCE FRAME)

TIME (SEC)	PELVIS		CHEST	
	PITCH (DEG)	ROLL (DEG)	PITCH (DEG)	ROLL (DEG)
0.000	0.000	0.00	0.00	0.00
.008	.038	0.00	-.02	0.00
.012	.101	0.00	-.04	0.00
.018	.150	0.00	-.02	0.00
.023	.184	0.00	.05	0.00
.030	.184	0.00	.14	0.00
.038	.124	0.00	.23	0.00
.042	.053	0.00	.27	0.00
.048	-.082	0.00	.25	0.00
.054	-.318	0.00	.12	0.00
.080	-.878	0.00	-.14	0.00
.088	-1.211	0.00	-.54	0.00
.072	-1.828	0.00	-1.11	0.00
.078	-2.820	0.00	-1.83	0.00
.084	-3.802	0.00	-2.78	0.00
.080	-4.808	0.00	-3.88	0.00
.088	-5.812	0.00	-5.07	0.00
.102	-6.802	0.00	-6.33	0.00
.108	-7.788	0.00	-7.61	0.00
.114	-8.712	0.00	-8.84	0.00
.120	-8.638	0.00	-10.01	0.00
.128	-10.540	0.00	-11.12	0.00
.132	-11.414	0.00	-12.18	0.00
.138	-12.238	0.00	-13.25	0.00
.144	-12.880	0.00	-14.31	0.00
.150	-13.814	0.00	-15.40	0.00
.158	-14.140	0.00	-16.48	0.00
.162	-14.588	0.00	-17.58	0.00
.168	-14.871	0.00	-18.65	0.00
.174	-15.188	0.00	-19.83	0.00
.180	-15.547	0.00	-20.92	0.00
.188	-15.828	0.00	-21.93	0.00
.182	-16.325	0.00	-22.08	0.00
.188	-16.707	0.00	-22.78	0.00
.204	-17.057	0.00	-23.42	0.00
.210	-17.330	0.00	-24.07	0.00
.218	-17.538	0.00	-24.68	0.00
.222	-17.680	0.00	-25.23	0.00
.228	-17.705	0.00	-25.70	0.00
.234	-17.888	0.00	-26.06	0.00
.240	-17.818	0.00	-26.30	0.00
.248	-17.488	0.00	-26.41	0.00
.252	-17.307	0.00	-26.38	0.00
.258	-17.084	0.00	-26.21	0.00
.264	-16.844	0.00	-25.80	0.00
.270	-16.587	0.00	-25.48	0.00
.278	-16.275	0.00	-24.86	0.00
.282	-16.001	0.00	-24.34	0.00
.288	-15.778	0.00	-23.64	0.00
.284	-15.817	0.00	-22.88	0.00

OCCUPANT SEGMENT POSITION
(IN AIRCRAFT REFERENCE FRAME)

TIME (SEC)	HEAD			NECK		
	X (IN)	Y (IN)	Z (IN)	X (IN)	Y (IN)	Z (IN)
0.000	10.38	0.00	47.21	7.30	0.00	41.83
.008	10.40	0.00	47.21	7.31	0.00	41.83
.012	10.41	0.00	47.18	7.32	0.00	41.81
.018	10.45	0.00	47.18	7.38	0.00	41.80
.025	10.55	0.00	47.14	7.45	0.00	41.80
.030	10.71	0.00	47.14	7.58	0.00	41.80
.038	10.84	0.00	47.13	7.78	0.00	41.80
.042	11.22	0.00	47.10	8.04	0.00	41.77
.048	11.51	0.00	47.04	8.32	0.00	41.70
.054	11.83	0.00	46.82	8.63	0.00	41.58
.060	12.13	0.00	46.75	8.83	0.00	41.43
.068	12.42	0.00	46.52	8.22	0.00	41.22
.072	12.87	0.00	46.25	8.48	0.00	40.86
.078	12.87	0.00	45.81	8.71	0.00	40.65
.084	13.12	0.00	45.54	10.00	0.00	40.30
.090	13.14	0.00	45.13	10.07	0.00	39.93
.098	13.23	0.00	44.72	10.22	0.00	39.57
.102	13.30	0.00	44.34	10.35	0.00	39.28
.108	13.37	0.00	44.05	10.48	0.00	39.03
.114	13.44	0.00	43.36	10.55	0.00	38.88
.120	13.48	0.00	43.78	10.62	0.00	38.86
.128	13.51	0.00	43.80	10.88	0.00	38.81
.132	13.50	0.00	43.88	10.88	0.00	38.00
.138	13.35	0.00	44.02	10.58	0.00	38.10
.144	13.22	0.00	44.18	10.54	0.00	38.21
.150	13.05	0.00	44.35	10.47	0.00	38.30
.158	12.83	0.00	44.50	10.38	0.00	38.34
.162	12.58	0.00	44.62	10.28	0.00	38.35
.168	12.31	0.00	44.88	10.17	0.00	38.31
.174	12.02	0.00	44.71	10.04	0.00	38.24
.180	11.73	0.00	44.68	9.81	0.00	38.13
.188	11.45	0.00	44.64	9.78	0.00	38.01
.192	11.18	0.00	44.57	9.61	0.00	38.88
.198	10.82	0.00	44.48	9.48	0.00	38.78
.204	10.68	0.00	44.41	9.31	0.00	38.88
.210	10.47	0.00	44.35	9.17	0.00	38.61
.216	10.28	0.00	44.30	9.04	0.00	38.55
.222	10.12	0.00	44.28	8.82	0.00	38.53
.228	9.88	0.00	44.28	8.83	0.00	38.53
.234	9.88	0.00	44.32	8.78	0.00	38.57
.240	9.82	0.00	44.38	8.71	0.00	38.63
.248	9.78	0.00	44.48	8.68	0.00	38.71
.252	9.78	0.00	44.60	8.70	0.00	38.81
.258	9.82	0.00	44.72	8.74	0.00	38.81
.264	9.88	0.00	44.84	8.80	0.00	38.02
.270	9.88	0.00	44.85	8.88	0.00	38.12
.278	10.08	0.00	45.05	8.84	0.00	38.21
.282	10.14	0.00	45.13	8.86	0.00	38.28
.288	10.14	0.00	45.18	8.81	0.00	38.34
.294	10.08	0.00	45.23	8.78	0.00	38.38

OCCUPANT SEGMENT POSITION
(IN AIRCRAFT REFERENCE FRAME)

TIME (SEC)	HEAD		NECK	
	PITCH (DEG)	ROLL (DEG)	PITCH (DEG)	ROLL (DEG)
0.000	23.000	0.00	11.50	0.00
.006	23.005	0.00	11.49	0.00
.012	22.992	0.00	11.49	0.00
.018	23.034	0.00	11.51	0.00
.025	23.233	0.00	11.64	0.00
.030	23.623	0.00	11.88	0.00
.036	24.111	0.00	12.17	0.00
.042	24.590	0.00	12.42	0.00
.048	24.852	0.00	12.60	0.00
.054	25.278	0.00	12.70	0.00
.060	25.824	0.00	12.74	0.00
.066	26.031	0.00	12.74	0.00
.072	26.488	0.00	12.69	0.00
.078	26.843	0.00	12.58	0.00
.084	27.382	0.00	12.32	0.00
.090	27.808	0.00	11.97	0.00
.096	28.185	0.00	11.58	0.00
.102	28.788	0.00	11.23	0.00
.108	28.701	0.00	11.05	0.00
.114	30.885	0.00	11.03	0.00
.120	32.184	0.00	11.08	0.00
.126	33.317	0.00	11.10	0.00
.132	33.872	0.00	10.89	0.00
.138	33.849	0.00	10.35	0.00
.144	33.152	0.00	9.42	0.00
.150	31.888	0.00	8.15	0.00
.156	29.684	0.00	6.60	0.00
.162	27.263	0.00	4.84	0.00
.168	24.602	0.00	2.98	0.00
.174	21.883	0.00	1.13	0.00
.180	19.346	0.00	-0.59	0.00
.186	17.103	0.00	-2.11	0.00
.192	15.282	0.00	-3.40	0.00
.198	13.858	0.00	-4.45	0.00
.204	12.824	0.00	-5.30	0.00
.210	12.060	0.00	-6.01	0.00
.216	11.487	0.00	-6.60	0.00
.222	11.017	0.00	-7.11	0.00
.228	10.697	0.00	-7.50	0.00
.234	10.481	0.00	-7.78	0.00
.240	10.318	0.00	-7.99	0.00
.246	10.183	0.00	-8.12	0.00
.252	9.984	0.00	-8.19	0.00
.258	9.824	0.00	-8.19	0.00
.264	9.699	0.00	-8.11	0.00
.270	9.625	0.00	-7.93	0.00
.276	9.667	0.00	-7.64	0.00
.282	9.828	0.00	-7.28	0.00
.288	10.090	0.00	-6.77	0.00
.294	10.473	0.00	-6.19	0.00

OCCUPANT SEGMENT POSITION
(IN AIRCRAFT REFERENCE FRAME)

TIME (SEC)	RIGHT UPPER ARM			RIGHT LOWER ARM		
	X (IN)	Y (IN)	Z (IN)	X (IN)	Y (IN)	Z (IN)
0.000	8.88	-8.34	34.32	18.70	-8.34	28.82
.006	8.89	-8.34	34.31	18.71	-8.34	28.81
.012	8.71	-8.34	34.30	18.73	-8.34	28.80
.019	8.74	-8.34	34.28	18.77	-8.34	28.58
.025	8.82	-8.34	34.28	18.83	-8.34	28.57
.030	8.85	-8.34	34.28	18.85	-8.34	28.55
.036	8.14	-8.34	34.28	17.13	-8.34	28.53
.042	8.38	-8.34	34.25	17.37	-8.34	28.50
.048	8.68	-8.34	34.18	17.68	-8.34	28.48
.054	10.02	-8.34	34.08	18.07	-8.34	28.41
.060	10.38	-8.34	33.84	18.52	-8.34	28.35
.068	10.77	-8.34	33.75	18.03	-8.34	28.28
.072	11.17	-8.34	33.53	18.58	-8.34	28.22
.078	11.58	-8.34	33.27	20.18	-8.34	28.17
.084	12.05	-8.34	32.98	20.93	-8.34	28.15
.080	12.38	-8.34	32.70	21.50	-8.34	28.16
.086	12.75	-8.34	32.44	22.18	-8.34	28.21
.102	13.13	-8.34	32.24	22.80	-8.34	28.33
.108	13.48	-8.34	32.13	23.38	-8.34	28.50
.114	13.78	-8.34	32.11	23.80	-8.34	28.75
.120	14.04	-8.34	32.18	24.35	-8.34	27.05
.126	14.28	-8.34	32.33	24.73	-8.34	27.41
.132	14.44	-8.34	32.53	25.05	-8.34	27.82
.138	14.50	-8.34	32.74	25.28	-8.34	28.25
.144	14.61	-8.34	32.88	25.51	-8.34	28.71
.150	14.71	-8.34	33.17	25.74	-8.34	29.20
.158	14.78	-8.34	33.35	25.85	-8.34	29.68
.162	14.85	-8.34	33.51	26.15	-8.34	30.20
.168	14.90	-8.34	33.63	26.33	-8.34	30.71
.174	14.83	-8.34	33.72	26.48	-8.34	31.21
.180	14.85	-8.34	33.78	26.58	-8.34	31.71
.186	14.84	-8.34	33.85	26.67	-8.34	32.20
.192	14.81	-8.34	33.90	26.70	-8.34	32.67
.198	14.88	-8.34	33.85	26.70	-8.34	33.12
.204	14.81	-8.34	34.00	26.86	-8.34	33.54
.210	14.75	-8.34	34.08	26.81	-8.34	33.83
.218	14.68	-8.34	34.13	26.55	-8.34	34.28
.222	14.64	-8.34	34.21	26.50	-8.34	34.62
.228	14.58	-8.34	34.30	26.44	-8.34	34.91
.234	14.56	-8.34	34.40	26.40	-8.34	35.17
.240	14.54	-8.34	34.51	26.37	-8.34	35.38
.246	14.53	-8.34	34.62	26.38	-8.34	35.58
.252	14.55	-8.34	34.74	26.37	-8.34	35.73
.258	14.58	-8.34	34.84	26.40	-8.34	35.85
.264	14.62	-8.34	34.94	26.45	-8.34	35.94
.270	14.68	-8.34	35.02	26.50	-8.34	35.88
.276	14.71	-8.34	35.08	26.54	-8.34	36.02
.282	14.68	-8.34	35.12	26.53	-8.34	36.01
.288	14.60	-8.34	35.14	26.44	-8.34	35.97
.294	14.43	-8.34	35.15	26.27	-8.34	35.80

OCCUPANT SEGMENT POSITION
(IN AIRCRAFT REFERENCE FRAME)

TIME (SEC)	RIGHT UPPER ARM		RIGHT LOWER ARM	
	PITCH (DEG)	ROLL (DEG)	PITCH (DEG)	ROLL (DEG)
0.000	-17.000	0.00	13.00	0.00
.006	-17.010	0.00	13.00	0.00
.012	-17.021	0.00	13.00	0.00
.018	-16.884	0.00	13.04	0.00
.025	-16.828	0.00	13.14	0.00
.030	-16.841	0.00	13.28	0.00
.036	-16.784	0.00	13.33	0.00
.042	-16.783	0.00	13.34	0.00
.048	-16.802	0.00	13.20	0.00
.054	-17.241	0.00	12.87	0.00
.060	-17.850	0.00	12.30	0.00
.066	-18.787	0.00	11.47	0.00
.072	-20.128	0.00	10.39	0.00
.078	-21.835	0.00	8.07	0.00
.084	-23.804	0.00	7.55	0.00
.090	-26.283	0.00	5.88	0.00
.096	-28.754	0.00	4.22	0.00
.102	-31.288	0.00	2.69	0.00
.108	-33.886	0.00	1.36	0.00
.114	-35.812	0.00	.29	0.00
.120	-37.820	0.00	-.58	0.00
.126	-39.748	0.00	-1.28	0.00
.132	-41.485	0.00	-1.89	0.00
.138	-43.189	0.00	-2.60	0.00
.144	-44.805	0.00	-3.37	0.00
.150	-46.740	0.00	-4.20	0.00
.156	-48.710	0.00	-5.25	0.00
.162	-50.807	0.00	-6.81	0.00
.168	-53.011	0.00	-8.54	0.00
.174	-55.283	0.00	-11.40	0.00
.180	-57.806	0.00	-13.35	0.00
.186	-59.873	0.00	-15.31	0.00
.192	-82.029	0.00	-17.23	0.00
.198	-84.030	0.00	-18.08	0.00
.204	-85.846	0.00	-20.84	0.00
.210	-87.487	0.00	-22.45	0.00
.216	-88.887	0.00	-23.88	0.00
.222	-70.088	0.00	-25.06	0.00
.228	-71.081	0.00	-26.04	0.00
.234	-71.812	0.00	-26.79	0.00
.240	-72.357	0.00	-27.33	0.00
.246	-72.718	0.00	-27.69	0.00
.252	-72.818	0.00	-27.88	0.00
.258	-72.888	0.00	-27.98	0.00
.264	-72.854	0.00	-27.82	0.00
.270	-72.831	0.00	-27.79	0.00
.276	-72.839	0.00	-27.59	0.00
.282	-72.395	0.00	-27.34	0.00
.288	-72.087	0.00	-27.04	0.00
.294	-71.728	0.00	-26.68	0.00

OCCUPANT SEGMENT POSITION
(IN AIRCRAFT REFERENCE FRAME)

TIME (SEC)	LEFT UPPER ARM			LEFT LOWER ARM		
	X (IN)	Y (IN)	Z (IN)	X (IN)	Y (IN)	Z (IN)
0.000	8.68	8.34	34.32	18.70	8.34	28.82
.008	8.68	8.34	34.31	18.71	8.34	28.81
.012	8.71	8.34	34.30	18.73	8.34	28.80
.018	8.74	8.34	34.28	18.77	8.34	28.78
.023	8.82	8.34	34.28	18.83	8.34	28.57
.030	8.85	8.34	34.28	18.85	8.34	28.55
.038	8.14	8.34	34.28	17.13	8.34	28.53
.042	8.38	8.34	34.25	17.37	8.34	28.50
.048	9.88	8.34	34.18	17.68	8.34	28.46
.054	10.02	8.34	34.08	18.07	8.34	28.41
.060	10.38	8.34	33.84	18.52	8.34	28.35
.068	10.77	8.34	33.75	18.03	8.34	28.28
.072	11.17	8.34	33.53	18.58	8.34	28.22
.078	11.56	8.34	33.27	20.18	8.34	28.17
.084	12.05	8.34	32.88	20.83	8.34	28.15
.088	12.38	8.34	32.70	21.50	8.34	28.18
.088	12.75	8.34	32.44	22.18	8.34	28.21
.102	13.13	8.34	32.24	22.80	8.34	28.33
.108	13.48	8.34	32.13	23.38	8.34	28.50
.114	13.78	8.34	32.11	23.80	8.34	28.75
.120	14.04	8.34	32.18	24.35	8.34	27.05
.128	14.28	8.34	32.33	24.73	8.34	27.41
.132	14.44	8.34	32.53	25.05	8.34	27.82
.138	14.50	8.34	32.74	25.28	8.34	28.25
.144	14.61	8.34	32.88	25.51	8.34	28.71
.150	14.71	8.34	33.17	25.74	8.34	28.20
.158	14.78	8.34	33.35	25.85	8.34	28.88
.162	14.85	8.34	33.51	28.15	8.34	30.20
.168	14.80	8.34	33.83	28.33	8.34	30.71
.174	14.83	8.34	33.72	28.48	8.34	31.21
.180	14.85	8.34	33.79	28.58	8.34	31.71
.186	14.84	8.34	33.85	28.87	8.34	32.20
.192	14.81	8.34	33.80	28.70	8.34	32.87
.198	14.88	8.34	33.85	28.70	8.34	33.12
.204	14.81	8.34	34.00	28.88	8.34	33.54
.210	14.75	8.34	34.08	28.81	8.34	33.83
.216	14.88	8.34	34.13	28.55	8.34	34.28
.222	14.84	8.34	34.21	28.50	8.34	34.82
.228	14.58	8.34	34.30	28.44	8.34	34.81
.234	14.58	8.34	34.40	28.40	8.34	35.17
.240	14.54	8.34	34.51	28.37	8.34	35.38
.248	14.53	8.34	34.62	28.38	8.34	35.58
.252	14.55	8.34	34.74	28.37	8.34	35.73
.258	14.58	8.34	34.84	28.40	8.34	35.85
.264	14.62	8.34	34.84	28.45	8.34	35.84
.270	14.68	8.34	35.02	28.50	8.34	35.88
.278	14.71	8.34	35.08	28.54	8.34	36.02
.282	14.68	8.34	35.12	28.53	8.34	36.01
.288	14.60	8.34	35.14	28.44	8.34	35.87
.284	14.43	8.34	35.15	28.27	8.34	35.80

OCCUPANT SEGMENT POSITION
(IN AIRCRAFT REFERENCE FRAME)

TIME (SEC)	LEFT UPPER ARM		LEFT LOWER ARM	
	PITCH (DEG)	ROLL (DEG)	PITCH (DEG)	ROLL (DEG)
0.000	-17.000	0.00	13.00	0.00
.008	-17.010	0.00	13.00	0.00
.012	-17.021	0.00	13.00	0.00
.018	-16.994	0.00	13.04	0.00
.025	-16.828	0.00	13.14	0.00
.030	-16.841	0.00	13.28	0.00
.038	-16.784	0.00	13.33	0.00
.042	-16.783	0.00	13.34	0.00
.048	-16.902	0.00	13.20	0.00
.054	-17.241	0.00	12.87	0.00
.060	-17.850	0.00	12.30	0.00
.068	-18.797	0.00	11.47	0.00
.072	-20.128	0.00	10.38	0.00
.078	-21.835	0.00	8.07	0.00
.084	-23.904	0.00	7.55	0.00
.090	-26.263	0.00	5.88	0.00
.098	-28.754	0.00	4.22	0.00
.102	-31.288	0.00	2.88	0.00
.108	-33.888	0.00	1.38	0.00
.114	-35.912	0.00	.29	0.00
.120	-37.820	0.00	-.58	0.00
.128	-38.748	0.00	-1.28	0.00
.132	-41.485	0.00	-1.88	0.00
.138	-43.189	0.00	-2.80	0.00
.144	-44.805	0.00	-3.75	0.00
.150	-46.740	0.00	-4.80	0.00
.158	-48.710	0.00	-6.25	0.00
.162	-50.807	0.00	-7.81	0.00
.168	-53.011	0.00	-9.54	0.00
.174	-55.283	0.00	-11.40	0.00
.180	-57.606	0.00	-13.35	0.00
.186	-59.873	0.00	-15.31	0.00
.192	-62.028	0.00	-17.23	0.00
.198	-64.030	0.00	-19.08	0.00
.204	-65.848	0.00	-20.84	0.00
.210	-67.487	0.00	-22.45	0.00
.218	-68.887	0.00	-23.88	0.00
.222	-70.088	0.00	-25.08	0.00
.228	-71.081	0.00	-26.04	0.00
.234	-71.812	0.00	-26.78	0.00
.240	-72.357	0.00	-27.33	0.00
.248	-72.718	0.00	-27.68	0.00
.252	-72.818	0.00	-27.88	0.00
.258	-72.888	0.00	-27.88	0.00
.264	-72.854	0.00	-27.82	0.00
.270	-72.831	0.00	-27.78	0.00
.276	-72.839	0.00	-27.58	0.00
.282	-72.385	0.00	-27.34	0.00
.288	-72.097	0.00	-27.04	0.00
.294	-71.728	0.00	-26.88	0.00

OCCUPANT SEGMENT POSITION
(IN AIRCRAFT REFERENCE FRAME)

TIME (SEC)	RIGHT THIGH			RIGHT LOWER LEG		
	X (IN)	Y (IN)	Z (IN)	X (IN)	Y (IN)	Z (IN)
0.000	15.85	-3.70	18.82	25.22	-3.70	8.80
.006	15.85	-3.70	18.83	25.21	-3.70	8.58
.012	15.85	-3.70	18.83	25.20	-3.70	8.58
.018	15.87	-3.70	18.84	25.22	-3.70	8.58
.025	15.85	-3.70	18.84	25.28	-3.70	8.58
.030	18.08	-3.70	19.84	25.42	-3.70	8.58
.036	18.28	-3.70	19.84	25.63	-3.70	8.58
.042	18.54	-3.70	18.82	25.80	-3.70	8.58
.048	18.86	-3.70	18.81	26.25	-3.70	8.58
.054	17.25	-3.70	18.57	26.68	-3.70	8.80
.060	17.68	-3.70	18.51	27.18	-3.70	8.80
.066	18.18	-3.70	19.43	27.78	-3.70	8.80
.072	18.67	-3.70	18.31	28.41	-3.70	8.81
.078	18.21	-3.70	19.18	28.12	-3.70	8.83
.084	18.78	-3.70	18.04	28.88	-3.70	8.88
.090	20.31	-3.70	18.81	30.67	-3.70	8.71
.096	20.84	-3.70	18.78	31.49	-3.70	8.77
.102	21.36	-3.70	18.88	32.33	-3.70	8.84
.108	21.85	-3.70	18.81	33.18	-3.70	8.83
.114	22.32	-3.70	18.58	34.04	-3.70	8.04
.120	22.78	-3.70	18.57	34.88	-3.70	9.18
.126	23.18	-3.70	18.59	35.72	-3.70	9.38
.132	23.58	-3.70	18.85	36.53	-3.70	8.57
.138	23.90	-3.70	18.72	37.31	-3.70	8.81
.144	24.21	-3.70	18.80	38.08	-3.70	10.10
.150	24.48	-3.70	18.88	38.78	-3.70	10.43
.156	24.71	-3.70	18.87	39.48	-3.70	10.82
.162	24.88	-3.70	18.05	40.11	-3.70	11.27
.168	25.04	-3.70	19.11	40.71	-3.70	11.77
.174	25.18	-3.70	18.16	41.28	-3.70	12.31
.180	25.25	-3.70	18.20	41.77	-3.70	12.87
.186	25.31	-3.70	18.23	42.23	-3.70	13.45
.192	25.38	-3.70	19.25	42.63	-3.70	14.04
.198	25.40	-3.70	18.28	42.98	-3.70	14.63
.204	25.43	-3.70	19.27	43.30	-3.70	15.21
.210	25.46	-3.70	18.29	43.56	-3.70	15.78
.216	25.47	-3.70	19.32	43.78	-3.70	16.32
.222	25.48	-3.70	19.38	43.95	-3.70	16.83
.228	25.49	-3.70	19.41	44.09	-3.70	17.31
.234	25.49	-3.70	18.48	44.20	-3.70	17.75
.240	25.48	-3.70	19.51	44.28	-3.70	18.18
.246	25.47	-3.70	19.56	44.34	-3.70	18.53
.252	25.45	-3.70	19.60	44.38	-3.70	18.88
.258	25.43	-3.70	18.64	44.40	-3.70	19.15
.264	25.40	-3.70	18.68	44.41	-3.70	19.40
.270	25.38	-3.70	18.87	44.38	-3.70	18.81
.276	25.28	-3.70	18.85	44.33	-3.70	18.80
.282	25.14	-3.70	18.82	44.20	-3.70	18.84
.288	24.82	-3.70	18.58	43.98	-3.70	20.03
.294	24.82	-3.70	18.55	43.70	-3.70	20.04

OCCUPANT SEGMENT POSITION
(IN AIRCRAFT REFERENCE FRAME)

TIME (SEC)	RIGHT THIGH		RIGHT LOWER LEG	
	PITCH (DEG)	ROLL (DEG)	PITCH (DEG)	ROLL (DEG)
0.000	.861	0.00	-8.38	0.00
.006	1.001	0.00	-8.37	0.00
.012	1.087	0.00	-8.32	0.00
.018	1.112	0.00	-8.27	0.00
.025	1.133	0.00	-8.23	0.00
.030	1.123	0.00	-8.23	0.00
.036	1.086	0.00	-8.28	0.00
.042	1.001	0.00	-8.36	0.00
.048	.861	0.00	-8.50	0.00
.054	.634	0.00	-8.73	0.00
.060	.274	0.00	-7.08	0.00
.066	-.257	0.00	-7.81	0.00
.072	-.877	0.00	-8.34	0.00
.078	-1.653	0.00	-8.25	0.00
.084	-2.817	0.00	-10.38	0.00
.090	-3.783	0.00	-11.74	0.00
.096	-4.578	0.00	-13.33	0.00
.102	-5.183	0.00	-15.13	0.00
.108	-5.570	0.00	-17.10	0.00
.114	-5.755	0.00	-18.23	0.00
.120	-5.750	0.00	-21.48	0.00
.126	-5.575	0.00	-23.84	0.00
.132	-5.288	0.00	-26.29	0.00
.138	-4.888	0.00	-28.85	0.00
.144	-4.521	0.00	-31.51	0.00
.150	-4.237	0.00	-34.28	0.00
.158	-4.081	0.00	-37.20	0.00
.162	-4.117	0.00	-40.28	0.00
.168	-4.318	0.00	-43.45	0.00
.174	-4.620	0.00	-46.73	0.00
.180	-4.986	0.00	-50.05	0.00
.186	-5.341	0.00	-53.38	0.00
.182	-5.728	0.00	-56.70	0.00
.188	-6.088	0.00	-58.84	0.00
.204	-6.415	0.00	-63.04	0.00
.210	-6.870	0.00	-65.98	0.00
.218	-6.838	0.00	-68.73	0.00
.222	-6.837	0.00	-71.27	0.00
.228	-6.872	0.00	-73.62	0.00
.234	-6.850	0.00	-75.78	0.00
.240	-6.874	0.00	-77.77	0.00
.246	-6.748	0.00	-78.58	0.00
.252	-6.575	0.00	-81.23	0.00
.258	-6.358	0.00	-82.73	0.00
.264	-6.111	0.00	-84.10	0.00
.270	-5.848	0.00	-85.37	0.00
.276	-5.585	0.00	-86.62	0.00
.282	-5.308	0.00	-87.73	0.00
.288	-5.108	0.00	-88.54	0.00
.294	-4.988	0.00	-88.91	0.00

OCCUPANT SEGMENT POSITION
(IN AIRCRAFT REFERENCE FRAME)

TIME (SEC)	LEFT THIGH			LEFT LOWER LEG		
	X (IN)	Y (IN)	Z (IN)	X (IN)	Y (IN)	Z (IN)
0.000	15.85	3.70	19.82	25.22	3.70	8.60
.006	15.85	3.70	19.83	25.21	3.70	8.59
.012	15.85	3.70	19.83	25.20	3.70	8.59
.018	15.87	3.70	19.84	25.22	3.70	8.59
.023	15.85	3.70	19.84	25.29	3.70	8.59
.030	18.08	3.70	19.7	25.42	3.70	8.59
.036	18.28	3.70	19.	25.63	3.70	8.59
.042	18.54	3.70	19.82	25.80	3.70	8.59
.048	18.86	3.70	19.81	26.25	3.70	8.59
.054	17.25	3.70	19.57	26.68	3.70	8.60
.060	17.69	3.70	19.51	27.18	3.70	8.60
.066	18.18	3.70	19.43	27.76	3.70	8.60
.072	18.67	3.70	19.31	28.41	3.70	8.61
.078	19.21	3.70	19.18	29.12	3.70	8.63
.084	19.76	3.70	19.04	29.88	3.70	8.66
.090	20.31	3.70	18.81	30.67	3.70	8.71
.096	20.84	3.70	18.78	31.49	3.70	8.77
.102	21.36	3.70	18.68	32.33	3.70	8.84
.108	21.85	3.70	18.61	33.18	3.70	8.93
.114	22.32	3.70	18.58	34.04	3.70	9.04
.120	22.78	3.70	18.57	34.89	3.70	9.18
.128	23.18	3.70	18.58	35.72	3.70	9.36
.132	23.56	3.70	18.65	36.53	3.70	9.57
.138	23.80	3.70	18.72	37.31	3.70	9.81
.144	24.21	3.70	18.80	38.08	3.70	10.10
.150	24.49	3.70	18.89	38.79	3.70	10.43
.156	24.71	3.70	18.97	39.48	3.70	10.82
.162	24.89	3.70	19.05	40.11	3.70	11.27
.168	25.04	3.70	19.11	40.71	3.70	11.77
.174	25.18	3.70	19.16	41.28	3.70	12.31
.180	25.25	3.70	19.20	41.77	3.70	12.87
.186	25.31	3.70	19.23	42.23	3.70	13.45
.192	25.36	3.70	19.25	42.63	3.70	14.04
.198	25.40	3.70	19.26	42.98	3.70	14.63
.204	25.43	3.70	19.27	43.30	3.70	15.21
.210	25.46	3.70	19.28	43.58	3.70	15.78
.216	25.47	3.70	19.32	43.78	3.70	16.32
.222	25.48	3.70	19.36	43.85	3.70	16.83
.228	25.49	3.70	19.41	44.09	3.70	17.31
.234	25.49	3.70	19.46	44.20	3.70	17.75
.240	25.49	3.70	19.51	44.28	3.70	18.16
.246	25.47	3.70	19.56	44.34	3.70	18.53
.252	25.45	3.70	19.60	44.38	3.70	18.86
.258	25.43	3.70	19.64	44.40	3.70	19.15
.264	25.40	3.70	19.66	44.41	3.70	19.40
.270	25.36	3.70	19.67	44.39	3.70	19.61
.276	25.29	3.70	19.65	44.33	3.70	19.80
.282	25.14	3.70	19.62	44.20	3.70	19.94
.288	24.82	3.70	19.58	43.89	3.70	20.03
.294	24.62	3.70	19.55	43.70	3.70	20.04

OCCUPANT SEGMENT POSITION
(IN AIRCRAFT REFERENCE FRAME)

TIME (SEC)	LEFT THIGH		LEFT LOWER LEG	
	PITCH (DEG)	ROLL (DEG)	PITCH (DEG)	ROLL (DEG)
0.000	.981	0.00	-8.38	0.00
.008	1.001	0.00	-8.37	0.00
.012	1.087	0.00	-8.32	0.00
.019	1.112	0.00	-8.27	0.00
.023	1.133	0.00	-8.25	0.00
.030	1.125	0.00	-8.25	0.00
.036	1.088	0.00	-8.28	0.00
.042	1.001	0.00	-8.36	0.00
.048	.861	0.00	-8.50	0.00
.054	.834	0.00	-8.73	0.00
.060	.274	0.00	-7.09	0.00
.066	-.257	0.00	-7.81	0.00
.072	-.877	0.00	-8.34	0.00
.078	-1.853	0.00	-8.25	0.00
.084	-2.817	0.00	-10.38	0.00
.090	-3.783	0.00	-11.74	0.00
.096	-4.576	0.00	-13.33	0.00
.102	-5.183	0.00	-15.13	0.00
.108	-5.570	0.00	-17.10	0.00
.114	-5.753	0.00	-19.23	0.00
.120	-5.750	0.00	-21.48	0.00
.128	-5.575	0.00	-23.84	0.00
.132	-5.288	0.00	-26.29	0.00
.138	-4.898	0.00	-28.85	0.00
.144	-4.521	0.00	-31.51	0.00
.150	-4.237	0.00	-34.28	0.00
.156	-4.081	0.00	-37.20	0.00
.162	-4.117	0.00	-40.28	0.00
.168	-4.318	0.00	-43.45	0.00
.174	-4.620	0.00	-46.73	0.00
.180	-4.968	0.00	-50.05	0.00
.186	-5.341	0.00	-53.38	0.00
.182	-5.728	0.00	-56.70	0.00
.188	-6.086	0.00	-59.84	0.00
.204	-6.415	0.00	-63.04	0.00
.210	-6.670	0.00	-65.88	0.00
.216	-6.838	0.00	-68.73	0.00
.222	-6.937	0.00	-71.27	0.00
.228	-6.872	0.00	-73.62	0.00
.234	-6.850	0.00	-75.78	0.00
.240	-6.874	0.00	-77.77	0.00
.246	-6.748	0.00	-79.58	0.00
.252	-6.575	0.00	-81.23	0.00
.258	-6.358	0.00	-82.73	0.00
.264	-6.111	0.00	-84.10	0.00
.270	-5.848	0.00	-85.37	0.00
.276	-5.585	0.00	-86.62	0.00
.282	-5.308	0.00	-87.73	0.00
.288	-5.108	0.00	-88.54	0.00
.294	-4.888	0.00	-88.81	0.00

OCCUPANT SEGMENT VELOCITY
(IN AIRCRAFT REFERENCE FRAME)

TIME (SEC)	PELVIS			CHEST		
	X (IPS)	Y (IPS)	Z (IPS)	X (IPS)	Y (IPS)	Z (IPS)
0.000	0.00	0.00	0.00	0.00	0.00	0.00
.006	.46	0.00	2.37	.99	0.00	-1.97
.012	1.89	0.00	2.57	2.83	0.00	-2.33
.019	8.84	0.00	1.82	8.89	0.00	-1.08
.025	17.14	0.00	-.05	18.70	0.00	-.31
.030	28.88	0.00	-1.56	28.07	0.00	-.01
.036	38.21	0.00	-2.87	38.58	0.00	-2.88
.042	47.25	0.00	-4.87	48.00	0.00	-7.57
.049	56.43	0.00	-8.80	52.43	0.00	-14.24
.054	64.41	0.00	-14.88	58.86	0.00	-22.12
.060	69.80	0.00	-22.85	58.05	0.00	-30.83
.066	74.75	0.00	-31.70	57.81	0.00	-38.13
.072	77.38	0.00	-40.42	55.21	0.00	-47.19
.078	78.75	0.00	-48.40	51.87	0.00	-53.89
.084	78.17	0.00	-47.88	48.82	0.00	-58.20
.090	77.90	0.00	-44.82	46.08	0.00	-59.47
.096	75.50	0.00	-37.52	43.25	0.00	-53.84
.102	72.22	0.00	-27.75	40.05	0.00	-42.82
.108	68.30	0.00	-17.84	36.38	0.00	-27.33
.114	63.81	0.00	-7.78	32.02	0.00	-10.04
.120	58.82	0.00	1.82	27.18	0.00	5.45
.126	53.57	0.00	10.45	22.26	0.00	16.74
.132	48.27	0.00	18.88	17.58	0.00	22.82
.138	43.10	0.00	20.05	13.24	0.00	24.08
.144	38.30	0.00	20.30	10.10	0.00	22.48
.150	33.38	0.00	17.82	6.81	0.00	17.47
.156	28.40	0.00	13.37	3.87	0.00	10.86
.162	23.48	0.00	7.83	1.28	0.00	4.10
.168	18.48	0.00	2.15	-1.50	0.00	-2.88
.174	13.25	0.00	-1.53	-5.05	0.00	-8.88
.180	8.47	0.00	-4.35	-8.82	0.00	-13.03
.186	5.07	0.00	-8.85	-11.37	0.00	-14.48
.192	3.05	0.00	-8.48	-13.13	0.00	-13.85
.198	1.77	0.00	-7.81	-13.86	0.00	-12.12
.204	1.08	0.00	-5.33	-13.47	0.00	-8.48
.210	.53	0.00	-1.55	-12.34	0.00	-8.09
.216	.34	0.00	2.25	-10.58	0.00	-1.88
.222	.38	0.00	5.31	-8.48	0.00	2.71
.228	.17	0.00	8.01	-6.73	0.00	7.08
.234	-.03	0.00	8.88	-4.80	0.00	10.86
.240	-.40	0.00	11.31	-2.75	0.00	13.85
.246	-1.01	0.00	12.32	-.58	0.00	15.50
.252	-1.42	0.00	12.24	2.08	0.00	18.05
.258	-2.18	0.00	11.78	4.13	0.00	15.33
.264	-2.84	0.00	8.87	6.07	0.00	13.88
.270	-6.48	0.00	6.83	4.80	0.00	11.78
.276	-14.45	0.00	3.58	-2.08	0.00	8.85
.282	-28.72	0.00	.17	-13.43	0.00	5.86
.288	-41.20	0.00	-1.71	-27.33	0.00	2.87
.294	-53.88	0.00	-2.30	-38.58	0.00	1.74

OCCUPANT SEGMENT VELOCITY
(IN AIRCRAFT REFERENCE FRAME)

TIME (SEC)	RIGHT UPPER ARM			RIGHT LOWER ARM		
	X (IPS)	Y (IPS)	Z (IPS)	X (IPS)	Y (IPS)	Z (IPS)
0.000	0.00	0.00	0.00	0.00	0.00	0.00
.008	4.18	0.00	-1.88	4.58	0.00	-1.87
.012	5.88	0.00	-2.35	5.79	0.00	-2.63
.019	11.30	0.00	-1.44	8.85	0.00	-2.83
.023	18.91	0.00	.00	14.84	0.00	-2.44
.030	27.88	0.00	-.25	28.06	0.00	-2.65
.038	35.88	0.00	-2.75	34.55	0.00	-3.80
.042	47.14	0.00	-7.11	48.40	0.00	-8.00
.048	52.91	0.00	-13.09	57.86	0.00	-8.18
.054	61.57	0.00	-20.06	71.73	0.00	-9.87
.060	64.98	0.00	-27.38	81.51	0.00	-10.80
.068	64.85	0.00	-34.30	88.52	0.00	-10.58
.072	67.52	0.00	-40.44	88.63	0.00	-8.18
.078	65.29	0.00	-45.25	102.73	0.00	-8.48
.084	66.42	0.00	-47.81	108.23	0.00	-1.88
.090	66.64	0.00	-48.41	111.70	0.00	4.73
.098	64.67	0.00	-39.40	108.23	0.00	13.27
.102	60.85	0.00	-27.81	102.81	0.00	23.47
.108	55.01	0.00	-12.14	82.87	0.00	34.57
.114	47.68	0.00	4.38	80.73	0.00	45.55
.120	39.82	0.00	18.87	68.74	0.00	55.54
.128	33.02	0.00	28.72	58.71	0.00	64.02
.132	27.67	0.00	38.00	51.80	0.00	70.84
.138	-158.24	0.00	-1.88	-132.81	0.00	38.28
.144	18.82	0.00	38.45	38.71	0.00	78.20
.150	14.18	0.00	33.05	37.18	0.00	81.87
.158	11.82	0.00	28.34	34.68	0.00	83.78
.162	9.80	0.00	23.28	31.63	0.00	84.71
.168	7.38	0.00	18.22	27.82	0.00	84.83
.174	4.14	0.00	13.58	22.51	0.00	83.80
.180	.84	0.00	10.30	18.14	0.00	82.28
.186	-2.97	0.00	8.71	8.13	0.00	78.80
.192	-8.14	0.00	8.31	2.52	0.00	78.61
.198	-8.58	0.00	8.45	-3.15	0.00	72.66
.204	-9.87	0.00	8.83	-7.38	0.00	68.08
.210	-9.88	0.00	10.33	-8.85	0.00	63.13
.216	-9.40	0.00	12.08	-9.84	0.00	57.48
.222	-8.21	0.00	14.32	-9.04	0.00	51.80
.228	-8.68	0.00	15.82	-8.80	0.00	48.13
.234	-4.78	0.00	17.57	-8.88	0.00	40.28
.240	-2.75	0.00	18.68	-4.10	0.00	34.27
.246	.45	0.00	18.04	-.40	0.00	28.78
.252	3.43	0.00	18.57	3.48	0.00	23.13
.258	6.52	0.00	17.03	6.75	0.00	17.58
.264	8.24	0.00	14.87	8.82	0.00	12.11
.270	8.28	0.00	12.08	8.74	0.00	8.82
.276	2.44	0.00	8.95	3.07	0.00	1.35
.282	-8.03	0.00	5.57	-7.28	0.00	-3.73
.288	-21.45	0.00	2.22	-20.87	0.00	-8.07
.294	-33.40	0.00	.01	-32.50	0.00	-14.25

OCCUPANT SEGMENT VELOCITY
(IN AIRCRAFT REFERENCE FRAME)

TIME (SEC)	LEFT UPPER ARM			LEFT LOWER ARM		
	X (IPS)	Y (IPS)	Z (IPS)	X (IPS)	Y (IPS)	Z (IPS)
0.000	0.00	0.00	0.00	0.00	0.00	0.00
.006	4.18	0.00	-1.88	4.58	0.00	-1.67
.012	5.68	0.00	-2.35	5.78	0.00	-2.63
.018	11.30	0.00	-1.44	8.85	0.00	-2.63
.025	18.91	0.00	.00	14.84	0.00	-2.44
.030	27.88	0.00	-.25	28.08	0.00	-2.65
.038	35.88	0.00	-2.75	34.55	0.00	-3.60
.042	47.14	0.00	-7.11	48.40	0.00	-6.00
.048	52.91	0.00	-13.08	57.88	0.00	-8.18
.054	61.57	0.00	-20.08	71.73	0.00	-8.87
.060	64.98	0.00	-27.36	81.51	0.00	-10.60
.066	64.85	0.00	-34.30	88.52	0.00	-10.56
.072	67.52	0.00	-40.44	88.63	0.00	-9.18
.078	65.29	0.00	-45.25	102.73	0.00	-6.48
.084	66.42	0.00	-47.81	108.23	0.00	-1.68
.090	66.84	0.00	-46.41	111.70	0.00	4.73
.098	64.87	0.00	-38.40	108.23	0.00	13.27
.102	60.85	0.00	-27.61	102.81	0.00	23.47
.108	55.01	0.00	-12.14	82.87	0.00	34.57
.114	47.68	0.00	4.38	80.73	0.00	45.55
.120	38.92	0.00	18.87	68.74	0.00	55.54
.126	33.02	0.00	28.72	58.71	0.00	64.02
.132	27.87	0.00	36.00	51.80	0.00	70.84
.138	-158.24	0.00	-1.88	-132.81	0.00	36.28
.144	18.82	0.00	36.45	38.71	0.00	78.20
.150	14.18	0.00	33.05	37.18	0.00	81.87
.158	11.82	0.00	28.34	34.88	0.00	85.78
.162	8.60	0.00	23.28	31.63	0.00	84.71
.168	7.38	0.00	18.22	27.82	0.00	84.83
.174	4.14	0.00	13.58	22.51	0.00	83.80
.180	.64	0.00	10.30	16.14	0.00	82.28
.186	-2.87	0.00	8.71	8.13	0.00	78.80
.192	-6.14	0.00	8.31	2.52	0.00	78.81
.198	-8.56	0.00	8.45	-3.15	0.00	72.68
.204	-9.87	0.00	8.83	-7.38	0.00	68.06
.210	-8.68	0.00	10.33	-8.85	0.00	63.13
.216	-8.40	0.00	12.08	-8.84	0.00	57.48
.222	-8.21	0.00	14.32	-8.04	0.00	51.80
.228	-6.68	0.00	15.82	-8.80	0.00	46.13
.234	-4.78	0.00	17.57	-6.88	0.00	40.28
.240	-2.75	0.00	18.88	-4.10	0.00	34.27
.248	.45	0.00	19.04	-.40	0.00	28.78
.252	3.43	0.00	18.57	3.46	0.00	23.13
.258	6.32	0.00	17.03	6.75	0.00	17.58
.264	9.24	0.00	14.87	8.82	0.00	12.11
.270	8.28	0.00	12.08	8.74	0.00	8.82
.276	2.44	0.00	8.85	3.07	0.00	1.35
.282	-8.03	0.00	5.57	-7.28	0.00	-3.73
.288	-21.45	0.00	2.22	-20.87	0.00	-8.07
.294	-33.40	0.00	.01	-32.50	0.00	-14.25

OCCUPANT SEGMENT VELOCITY
(IN AIRCRAFT REFERENCE FRAME)

TIME (SEC)	RIGHT THIGH			RIGHT LOWER LEG		
	X (IPS)	Y (IPS)	Z (IPS)	X (IPS)	Y (IPS)	Z (IPS)
0.000	0.00	0.00	0.00	0.00	0.00	0.00
.008	-.39	0.00	.73	-1.74	0.00	-.27
.012	.88	0.00	1.38	-1.03	0.00	.70
.018	8.08	0.00	1.04	8.27	0.00	1.22
.025	18.89	0.00	.04	18.08	0.00	-.13
.030	27.08	0.00	-.84	28.70	0.00	.74
.038	38.78	0.00	-1.38	40.09	0.00	.14
.042	48.58	0.00	-2.28	51.55	0.00	1.80
.048	58.15	0.00	-4.34	64.18	0.00	.50
.054	68.45	0.00	-7.73	78.82	0.00	.82
.060	75.87	0.00	-11.83	88.04	0.00	1.08
.068	83.21	0.00	-18.48	102.28	0.00	.81
.072	88.12	0.00	-20.48	112.83	0.00	3.10
.078	90.88	0.00	-23.01	121.79	0.00	4.18
.084	91.57	0.00	-23.43	128.21	0.00	8.88
.080	90.10	0.00	-21.82	134.73	0.00	8.85
.088	87.83	0.00	-18.81	138.84	0.00	10.50
.102	84.34	0.00	-14.20	141.35	0.00	13.08
.108	80.48	0.00	-8.05	142.37	0.00	18.70
.114	78.13	0.00	-3.72	141.85	0.00	21.17
.120	71.30	0.00	1.83	140.13	0.00	28.15
.128	68.08	0.00	8.58	137.03	0.00	31.47
.132	60.42	0.00	10.58	132.82	0.00	37.24
.138	54.44	0.00	12.88	128.17	0.00	43.85
.144	48.05	0.00	14.28	122.83	0.00	51.28
.150	41.42	0.00	14.37	117.04	0.00	58.85
.158	34.72	0.00	13.41	110.87	0.00	68.07
.162	28.07	0.00	11.88	104.18	0.00	78.41
.168	21.88	0.00	8.85	98.70	0.00	87.21
.174	18.88	0.00	7.87	89.03	0.00	91.84
.180	12.81	0.00	5.80	80.72	0.00	85.45
.188	8.81	0.00	3.82	72.37	0.00	87.78
.192	7.32	0.00	2.28	64.07	0.00	88.88
.198	5.88	0.00	2.00	55.85	0.00	88.01
.204	4.80	0.00	2.78	47.85	0.00	85.25
.210	3.52	0.00	4.32	38.84	0.00	82.88
.218	2.41	0.00	5.85	32.88	0.00	87.18
.222	1.22	0.00	7.24	28.43	0.00	82.78
.228	.48	0.00	8.14	20.83	0.00	77.58
.234	-.38	0.00	8.48	18.08	0.00	71.70
.240	-1.25	0.00	8.38	12.55	0.00	63.84
.248	-2.14	0.00	7.82	7.88	0.00	58.08
.252	-3.44	0.00	6.87	4.78	0.00	52.04
.258	-4.28	0.00	5.02	1.75	0.00	45.55
.264	-5.47	0.00	2.88	-.88	0.00	38.15
.270	-8.88	0.00	-.80	-5.58	0.00	33.18
.278	-17.74	0.00	-4.11	-14.27	0.00	27.80
.282	-28.88	0.00	-8.12	-27.87	0.00	21.05
.288	-43.47	0.00	-8.44	-41.84	0.00	8.24
.284	-55.57	0.00	-5.80	-54.84	0.00	-3.88

OCCUPANT SEGMENT VELOCITY
(IN AIRCRAFT REFERENCE FRAME)

TIME (SEC)	LEFT THIGH			LEFT LOWER LEG		
	X (IPS)	Y (IPS)	Z (IPS)	X (IPS)	Y (IPS)	Z (IPS)
0.000	0.00	0.00	0.00	0.00	0.00	0.00
.006	-.39	0.00	.73	-1.74	0.00	-.27
.012	.96	0.00	1.39	-1.03	0.00	.70
.018	8.09	0.00	1.04	8.27	0.00	1.22
.023	16.69	0.00	.04	16.09	0.00	-.13
.030	27.06	0.00	-.84	26.70	0.00	.74
.036	36.79	0.00	-1.38	40.09	0.00	.14
.042	46.59	0.00	-2.26	51.53	0.00	1.60
.048	59.15	0.00	-4.34	64.19	0.00	.50
.054	68.45	0.00	-7.73	78.92	0.00	.82
.060	75.97	0.00	-11.83	89.04	0.00	1.08
.068	83.21	0.00	-16.48	102.26	0.00	.81
.072	88.12	0.00	-20.46	112.83	0.00	3.10
.078	90.88	0.00	-23.01	121.79	0.00	4.19
.084	91.57	0.00	-23.43	128.21	0.00	6.68
.090	90.10	0.00	-21.92	134.73	0.00	8.83
.096	87.63	0.00	-19.81	138.84	0.00	10.50
.102	84.34	0.00	-14.20	141.35	0.00	13.09
.108	80.48	0.00	-9.05	142.37	0.00	16.70
.114	76.13	0.00	-3.72	141.85	0.00	21.17
.120	71.30	0.00	1.63	140.13	0.00	26.15
.126	66.06	0.00	6.58	137.03	0.00	31.47
.132	60.42	0.00	10.56	132.92	0.00	37.24
.138	54.44	0.00	12.89	128.17	0.00	43.65
.144	48.05	0.00	14.26	122.83	0.00	51.28
.150	41.42	0.00	14.37	117.04	0.00	59.85
.156	34.72	0.00	13.41	110.87	0.00	69.07
.162	28.07	0.00	11.68	104.18	0.00	78.41
.168	21.88	0.00	9.65	96.70	0.00	87.21
.174	16.89	0.00	7.67	89.03	0.00	91.84
.180	12.91	0.00	5.60	80.72	0.00	95.45
.186	9.61	0.00	3.82	72.37	0.00	97.78
.192	7.32	0.00	2.26	64.07	0.00	98.99
.198	5.89	0.00	2.00	55.85	0.00	98.01
.204	4.60	0.00	2.79	47.85	0.00	95.25
.210	3.52	0.00	4.32	39.64	0.00	92.88
.216	2.41	0.00	5.85	32.98	0.00	87.19
.222	1.22	0.00	7.24	26.43	0.00	82.76
.228	.46	0.00	8.14	20.83	0.00	77.58
.234	-.39	0.00	8.48	16.09	0.00	71.70
.240	-1.25	0.00	8.36	12.53	0.00	63.94
.246	-2.14	0.00	7.82	7.99	0.00	59.08
.252	-3.44	0.00	6.87	4.76	0.00	52.04
.258	-4.26	0.00	5.02	1.75	0.00	45.55
.264	-5.47	0.00	2.68	-.88	0.00	38.15
.270	-6.88	0.00	-.80	-5.56	0.00	33.19
.276	-17.74	0.00	-4.11	-14.27	0.00	27.80
.282	-28.88	0.00	-6.12	-27.67	0.00	21.05
.288	-43.47	0.00	-6.44	-41.84	0.00	9.24
.294	-55.57	0.00	-5.60	-54.84	0.00	-3.66

OCCUPANT SEGMENT VELOCITY
(IN AIRCRAFT REFERENCE FRAME)

TIME (SEC)	HEAD		
	X (IPS)	Y (IPS)	Z (IPS)
0.000	0.00	0.00	0.00
.008	2.84	0.00	-2.15
.012	4.58	0.00	-3.82
.019	12.60	0.00	-3.85
.023	21.23	0.00	-2.07
.030	33.68	0.00	-.48
.036	42.28	0.00	-1.54
.042	48.68	0.00	-7.06
.048	51.33	0.00	-15.01
.054	53.85	0.00	-23.66
.060	51.23	0.00	-32.40
.066	44.88	0.00	-41.40
.072	38.11	0.00	-50.34
.078	29.38	0.00	-58.06
.084	22.50	0.00	-65.35
.090	16.83	0.00	-68.27
.096	13.38	0.00	-67.00
.102	12.08	0.00	-57.28
.108	11.43	0.00	-41.82
.114	9.90	0.00	-23.48
.120	6.56	0.00	-5.27
.126	1.28	0.00	10.07
.132	-5.53	0.00	20.88
.138	-183.33	0.00	-13.05
.144	-24.78	0.00	27.80
.150	-32.17	0.00	28.82
.158	-38.66	0.00	22.78
.162	-43.82	0.00	18.06
.168	-47.22	0.00	8.20
.174	-48.35	0.00	.55
.180	-48.15	0.00	-8.12
.186	-46.58	0.00	-10.93
.192	-44.12	0.00	-13.11
.198	-40.93	0.00	-12.85
.204	-37.37	0.00	-11.54
.210	-33.88	0.00	-8.55
.216	-28.50	0.00	-6.57
.222	-24.88	0.00	-2.18
.228	-18.64	0.00	3.45
.234	-14.20	0.00	9.15
.240	-8.35	0.00	13.86
.246	-3.06	0.00	17.31
.252	2.88	0.00	18.27
.258	8.50	0.00	18.86
.264	14.11	0.00	18.48
.270	18.47	0.00	17.88
.276	13.52	0.00	15.46
.282	5.44	0.00	12.07
.288	-4.82	0.00	8.45
.294	-14.32	0.00	5.58

OCUPANT SEIMENT ACCELERATION
(IN ACCELEROMETER DIRECTIONS)

TIME (SEC)	PELVIS			SCALE FACTOR = .158E+01
	X (G)	Y (G)	Z (G)	
0.000	0.00	0.00	0.00	
.006	-1.00	0.00	.16	
.012	-1.71	0.00	2.28	
.018	-1.00	0.00	1.44	
.025	-1.20	0.00	.32	
.030	-.72	0.00	-.01	
.036	-1.20	0.00	.10	
.042	-2.28	0.00	.27	
.048	-1.81	0.00	-2.54	
.054	-2.28	0.00	-3.06	
.060	-3.11	0.00	-4.81	
.066	-3.31	0.00	-4.62	
.072	-4.25	0.00	-3.87	
.078	-5.07	0.00	-2.06	
.084	-5.70	0.00	.08	
.090	-6.00	0.00	2.00	
.096	-6.25	0.00	4.57	
.102	-6.44	0.00	5.18	
.108	-6.80	0.00	5.25	
.114	-6.70	0.00	5.21	
.120	-6.80	0.00	5.23	
.126	-6.80	0.00	4.70	
.132	-7.11	0.00	3.90	
.138	-7.14	0.00	2.22	
.144	-7.87	0.00	1.24	
.150	-7.73	0.00	.28	
.156	-7.81	0.00	-.28	
.162	-7.80	0.00	-.38	
.168	-7.80	0.00	-.41	
.174	-7.60	0.00	-.38	
.180	-8.03	0.00	-.82	
.186	-8.13	0.00	-.87	
.192	-9.53	0.00	.13	
.198	-9.00	0.00	1.25	
.204	-8.70	0.00	2.18	
.210	-8.80	0.00	3.84	
.216	-8.40	0.00	2.30	
.222	-8.94	0.00	1.82	
.228	-8.51	0.00	1.16	
.234	-8.23	0.00	.57	
.240	-8.57	0.00	.06	
.246	-9.23	0.00	1.87	
.252	-8.44	0.00	4.71	
.258	-8.80	0.00	-.73	
.264	-9.00	0.00	-1.37	
.270	-8.60	0.00	1.80	
.276	-9.00	0.00	1.23	
.282	-9.81	0.00	1.24	
.288	-8.80	0.00	1.22	
.294	-8.15	0.00	1.52	

OCCUPANT SEATBELT ACCELERATION
(IN ACCELEROMETER DIRECTIONS)

TIME (SEC)	CHEST			SCALE FACTOR * .105E+01
	X (G)	Y (G)	Z (G)	
0.000	0.00	0.00	0.00	
.008	.42	0.00	-0.64	
.012	-3.60	0.00	.19	
.018	-2.85	0.00	.70	
.025	-2.01	0.00	.29	
.030	-1.06	0.00	-0.64	
.038	-2.46	0.00	-1.51	
.042	-4.29	0.00	-2.00	
.048	-2.54	0.00	-3.23	
.054	-3.38	0.00	-3.63	
.060	-4.39	0.00	-3.68	
.068	-4.08	0.00	-3.53	
.072	-6.28	0.00	-3.13	
.078	-6.44	0.00	-2.51	
.084	-6.83	0.00	-1.22	
.090	-6.60	0.00	1.74	
.098	-6.38	0.00	4.18	
.102	-6.21	0.00	6.81	
.108	-6.11	0.00	8.28	
.114	-6.27	0.00	8.34	
.120	-6.43	0.00	7.14	
.126	-6.88	0.00	5.15	
.132	-6.84	0.00	3.68	
.138	-6.68	0.00	1.81	
.144	-7.04	0.00	.14	
.150	-7.21	0.00	-0.72	
.156	-7.21	0.00	-0.83	
.162	-7.15	0.00	-0.64	
.168	-6.85	0.00	-0.50	
.174	-6.24	0.00	.00	
.180	-5.25	0.00	1.18	
.186	-4.84	0.00	2.14	
.192	-4.15	0.00	2.87	
.198	-3.72	0.00	2.82	
.204	-3.21	0.00	3.17	
.210	-4.11	0.00	3.44	
.216	-2.78	0.00	3.98	
.222	-2.38	0.00	3.88	
.228	-2.40	0.00	3.48	
.234	-2.18	0.00	3.18	
.240	-1.88	0.00	2.72	
.246	-3.88	0.00	2.38	
.252	-6.48	0.00	2.18	
.258	-2.78	0.00	1.27	
.264	-2.72	0.00	1.18	
.270	-3.85	0.00	1.19	
.276	-5.82	0.00	.88	
.282	-5.75	0.00	.62	
.288	-5.00	0.00	1.62	
.294	-3.81	0.00	1.58	

OCCUPANT SEATBELT ACCELERATION
(IN ACCELEROMETER DIRECTION)

TIME (SEC)	HEAD		
	X (G)	Y (G)	Z (G)
0.004	0.00	0.00	0.00
.006	.05	0.00	-.03
.012	1.47	0.00	-.02
.018	1.28	0.00	.06
.023	.87	0.00	1.22
.026	.18	0.00	.04
.026	-.87	0.00	-2.20
.042	-1.22	0.00	-4.11
.046	-3.00	0.00	-5.30
.054	-4.33	0.00	-6.14
.060	-5.32	0.00	-6.64
.065	-6.30	0.00	-7.24
.072	-6.87	0.00	-7.63
.078	-7.18	0.00	-7.29
.084	-7.46	0.00	-6.43
.090	-6.87	0.00	-4.24
.096	-7.23	0.00	-.87
.102	-7.80	0.00	2.00
.108	-6.87	0.00	3.00
.114	3.47	0.00	3.78
.120	-6.80	0.00	2.44
.126	-8.82	0.00	.27
.132	-8.23	0.00	-2.04
.138	-6.61	0.00	-3.73
.144	-7.43	0.00	-4.80
.150	-6.30	0.00	-5.41
.156	-5.80	0.00	-6.16
.162	-4.86	0.00	-6.24
.168	-4.34	0.00	-5.83
.174	-4.46	0.00	-5.14
.180	-4.46	0.00	-4.23
.186	-4.42	0.00	-2.82
.192	-4.30	0.00	-1.36
.198	-4.27	0.00	-.88
.204	-4.22	0.00	-.29
.210	-4.36	0.00	.82
.216	-4.41	0.00	.88
.222	-3.74	0.00	1.34
.228	-4.29	0.00	1.80
.234	-4.24	0.00	1.44
.240	-3.83	0.00	1.07
.246	-3.83	0.00	.41
.252	-2.15	0.00	.28
.258	-4.21	0.00	-.80
.264	-3.77	0.00	-1.23
.270	-2.41	0.00	-1.23
.276	-2.37	0.00	-1.71
.282	-2.84	0.00	-2.01
.288	-2.80	0.00	-1.83
.294	-2.33	0.00	-1.28

SCALE FACTOR = .162E+01

OCCUPANT SEDIMENT ACCELERATION
(RESULTS)

TIME (SEC)	PELVIS (G)	CHEST (G)	HEAD (G)
0.000	0.00	0.00	0.00
.008	.18	.77	.94
.012	2.06	3.04	1.47
.018	2.21	2.83	1.38
.025	1.34	2.03	1.48
.030	.72	1.24	.17
.038	1.38	2.00	2.40
.042	2.28	3.01	4.28
.048	3.12	4.11	6.85
.054	4.62	4.85	7.83
.060	5.01	5.88	8.83
.066	6.87	5.40	8.85
.072	5.87	7.02	10.33
.078	5.47	8.81	10.23
.084	5.74	7.63	8.80
.090	6.85	8.84	8.07
.096	7.75	7.81	7.31
.102	8.27	8.87	8.16
.108	8.43	10.28	8.42
.114	8.82	10.44	10.18
.120	8.84	8.81	10.18
.126	8.42	8.42	8.83
.132	7.88	7.81	8.47
.138	7.48	8.73	8.83
.144	7.38	7.84	8.77
.150	7.74	7.25	8.32
.156	7.82	7.27	8.34
.162	7.87	7.18	7.88
.168	7.81	8.87	7.38
.174	7.42	8.25	8.81
.180	8.88	8.48	8.15
.186	8.18	5.11	5.38
.192	3.33	4.84	4.85
.198	3.21	4.71	4.42
.204	3.24	4.38	4.23
.210	4.08	5.38	4.38
.216	3.04	4.33	4.48
.222	4.88	4.38	4.84
.228	4.88	4.22	4.88
.234	4.88	3.83	4.48
.240	4.97	3.27	3.88
.246	3.85	4.38	3.88
.252	7.88	8.84	2.18
.258	5.43	3.11	4.38
.264	5.28	2.88	3.87
.270	8.31	5.87	2.71
.276	8.81	5.88	3.88
.282	5.74	5.81	3.22
.288	3.15	5.18	3.24
.294	4.42	4.22	2.88

SCALE FACTOR = .120E+01

RESTRAINT SYSTEM LOADS

TIME RIGHT LAP LEFT LAP
(SECS) (LB) (LB)

SCALE FACTOR = .143E+02

TIME (SECS)	RIGHT LAP (LB)	LEFT LAP (LB)
0.000	0.00	0.00
.006	.21	.21
.012	.00	.00
.018	2.03	2.03
.025	13.04	13.04
.030	30.10	30.10
.036	63.12	63.12
.042	101.12	101.12
.048	130.04	130.04
.054	100.00	100.00
.060	210.03	210.03
.066	253.00	253.00
.072	270.32	270.32
.078	204.31	204.31
.084	307.33	307.33
.090	302.02	302.02
.096	300.03	300.03
.102	311.03	311.03
.108	321.10	321.10
.114	320.30	320.30
.120	340.30	340.30
.126	303.33	303.33
.132	370.02	370.02
.138	370.03	370.03
.144	304.04	304.04
.150	000.21	000.21
.156	411.11	411.11
.162	410.71	410.71
.168	410.17	410.17
.174	410.20	410.20
.180	410.01	410.01
.186	411.03	411.03
.192	000.01	000.01
.198	000.21	000.21
.204	300.32	300.32
.210	301.42	301.42
.216	300.30	300.30
.222	300.00	300.00
.228	300.43	300.43
.234	300.00	300.00
.240	300.02	300.02
.246	300.00	300.00
.252	301.00	301.00
.258	304.30	304.30
.264	300.03	300.03
.270	300.72	300.72
.276	307.33	307.33
.282	300.00	300.00
.288	374.00	374.00
.294	340.20	340.20

RESTRAINT SYSTEM LOADS

TIME RIGHT ON LEFT ON
(SEC) (LB) (LB)

SCALE FACTOR = .385E+02

TIME (SEC)	RIGHT ON (LB)	LEFT ON (LB)
0.000	0.00	0.00
0.008	0.00	0.00
0.012	0.00	0.00
0.018	0.00	0.00
0.025	10.40	10.40
0.030	33.41	33.41
0.035	63.00	63.00
0.042	102.18	102.18
0.048	141.37	141.37
0.054	182.02	182.02
0.060	223.44	223.44
0.065	266.04	266.04
0.072	298.18	298.18
0.078	308.05	308.05
0.084	328.03	328.03
0.090	318.05	318.05
0.095	310.54	310.54
0.102	317.00	317.00
0.108	323.04	323.04
0.114	327.08	327.08
0.120	331.00	331.00
0.125	303.00	303.00
0.132	279.00	279.00
0.138	298.38	298.38
0.144	308.13	308.13
0.150	308.00	308.00
0.156	308.33	308.33
0.162	302.38	302.38
0.168	343.00	343.00
0.174	328.00	328.00
0.180	314.33	314.33
0.186	298.21	298.21
0.192	278.28	278.28
0.198	281.07	281.07
0.204	243.04	243.04
0.210	231.03	231.03
0.216	218.02	218.02
0.222	204.00	204.00
0.228	184.37	184.37
0.234	188.00	188.00
0.240	182.38	182.38
0.246	188.33	188.33
0.252	181.11	181.11
0.258	183.00	183.00
0.264	188.28	188.28
0.270	188.28	188.28
0.276	200.04	200.04
0.282	184.00	184.00
0.288	174.00	174.00
0.294	128.03	128.03

SEVERITY INDEX

SCALE FACTOR = .000E+01

TIME	CHEST	HEAD
.000	0.00	0.00
.005	.04	.01
.012	.08	.02
.019	.13	.04
.025	.18	.06
.030	.24	.08
.035	.31	.10
.042	.39	.12
.048	.48	.14
.054	1.43	1.34
.060	2.00	2.35
.066	2.04	3.72
.072	4.00	5.48
.078	4.00	7.44
.084	5.70	9.42
.090	6.42	10.90
.096	7.23	11.85
.102	8.43	12.82
.108	10.20	14.21
.114	12.32	16.04
.120	14.28	18.04
.126	15.72	18.84
.132	16.70	21.67
.138	17.00	23.30
.144	18.20	24.00
.150	18.21	26.01
.156	20.07	27.25
.162	20.01	28.00
.168	21.73	29.30
.174	22.00	30.18
.180	22.00	30.04
.186	23.20	31.30
.192	23.82	31.83
.198	23.83	31.80
.204	24.21	32.12
.210	24.82	32.32
.216	24.80	32.32
.222	25.14	32.73
.228	25.37	32.87
.234	25.30	33.24
.240	25.80	33.43
.246	25.80	33.90
.252	26.20	33.71
.258	26.70	33.82
.264	27.00	33.82
.270	27.40	34.00
.276	27.80	34.00
.282	28.00	34.20
.288	28.81	34.23
.294	29.10	34.42

SYNTHIC RESPONSE INDEX

SCALE FACTOR = .732E-03

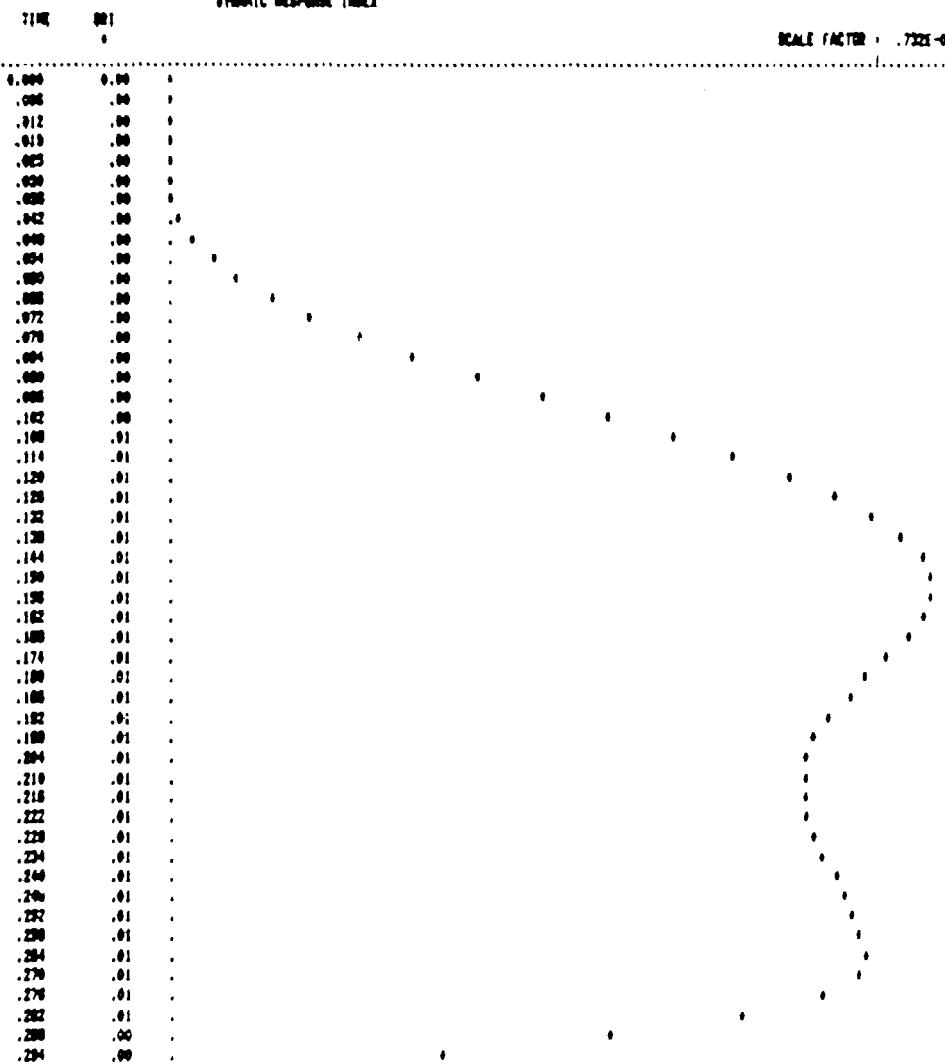

AXIAL LOADS IN VERTICAL ELEMENTS

TIME (SEC)	LOADING (LB)	RECE (LB)
0.000	0.00	0.00
.006	-23.25	-1.00
.012	-68.23	-7.05
.018	-108.82	-15.00
.025	-113.00	-23.00
.030	-143.25	-11.70
.036	-83.42	11.90
.042	-147.30	33.30
.048	-146.71	64.34
.054	-206.28	68.17
.060	-173.37	31.19
.066	-241.34	35.13
.072	-300.82	37.18
.078	-153.28	31.42
.084	-130.30	30.40
.090	-138.12	14.72
.096	-783.71	-28.42
.102	-880.80	-63.71
.108	-880.40	-66.18
.114	-473.83	-81.90
.120	-810.85	-60.90
.126	-882.78	-38.23
.132	-880.24	-22.22
.138	-578.80	-6.60
.144	-481.26	3.42
.150	-427.81	15.78
.156	-382.80	25.04
.162	-388.25	23.04
.168	-343.61	22.38
.174	-381.18	28.21
.180	-373.74	17.28
.186	-387.12	3.63
.192	-482.35	-18.88
.198	-382.30	-29.00
.204	-382.81	-23.18
.210	-374.32	-28.87
.216	-372.30	-25.71
.222	-388.80	-42.98
.228	-388.42	-46.44
.234	-329.82	-43.81
.240	-388.37	-37.30
.246	-377.28	-28.87
.252	-232.31	-22.84
.258	-238.80	-18.00
.264	-232.82	-11.91
.270	-228.32	-6.28
.276	-224.28	-1.94
.282	-218.80	1.88
.288	-218.25	1.22
.294	-224.25	-3.47

SCALE FACTOR = .1116E+02

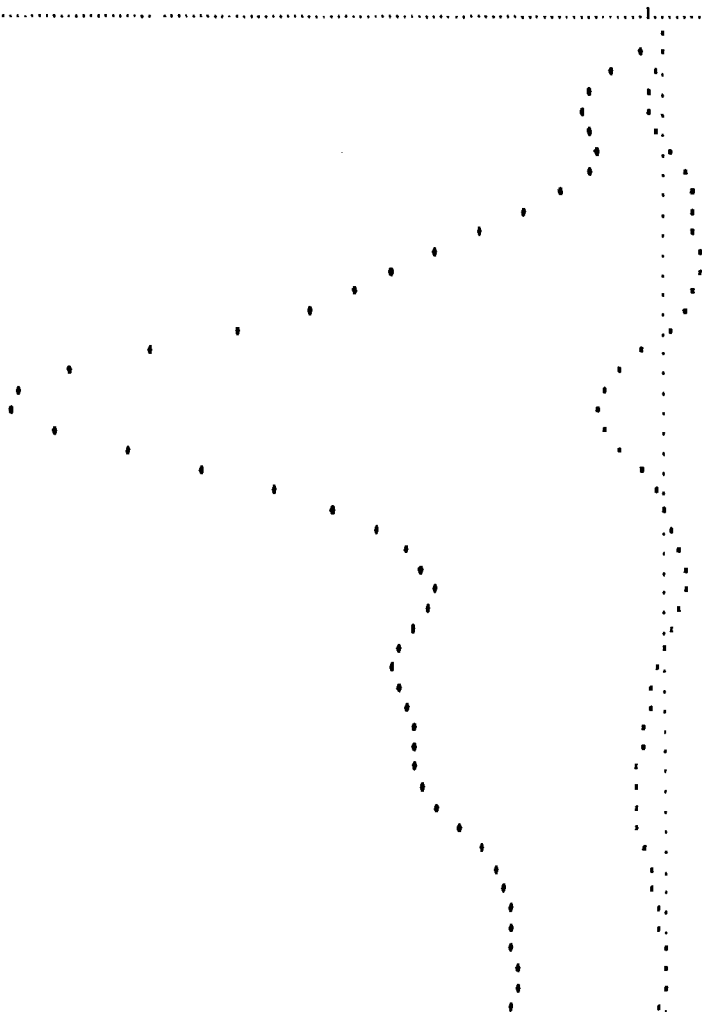

DYNAMIC RESPONSE INDEX AND HEAD SLAMMITY CRITERION
POSITION (M) WTC

.0 20.0

BETWEEN .0433 AND .1063 SEC

FINAL POINT USED IN RLC CALCULATION WAS AT .2306-00 SECONDS
BECAUSE OF STORAGE OVERFLOW

MINORITS IN VERTICAL ELEMENTS

TIME (SEC)	LONGITUDE (10-LS)	HEIGHT (10-LS)
0.000	0.00	0.00
.008	-38.43	1.00
.012	-38.47	.27
.018	-2.00	8.73
.023	13.00	22.02
.030	43.33	37.41
.038	66.17	47.23
.042	90.32	46.31
.048	82.15	51.24
.054	48.27	66.13
.060	33.81	80.03
.068	72.29	118.38
.072	64.77	143.68
.078	88.15	171.38
.084	-1.12	200.04
.090	-38.88	228.37
.098	-68.51	262.57
.102	-128.11	313.74
.108	-132.35	372.88
.114	-118.84	421.81
.120	-101.83	462.68
.128	-88.17	493.88
.132	-87.35	492.67
.138	-127.27	388.38
.144	-178.33	323.63
.150	-241.37	288.68
.158	-287.38	236.84
.162	-243.84	138.82
.168	-208.18	112.43
.174	-208.18	82.37
.180	-241.47	67.88
.188	-288.21	74.82
.192	-188.24	88.88
.198	-188.81	112.47
.204	-287.27	123.73
.210	-218.81	148.17
.218	-242.88	133.84
.222	-273.48	188.18
.228	-257.88	188.23
.234	-238.84	188.38
.240	-287.88	188.88
.248	-181.88	143.57
.252	-142.38	121.81
.258	-82.81	114.82
.264	-47.47	102.82
.270	-22.82	88.14
.278	18.73	82.88
.282	68.82	88.81
.288	148.78	88.81
.294	208.81	84.57

SCALE FACTOR = .000042

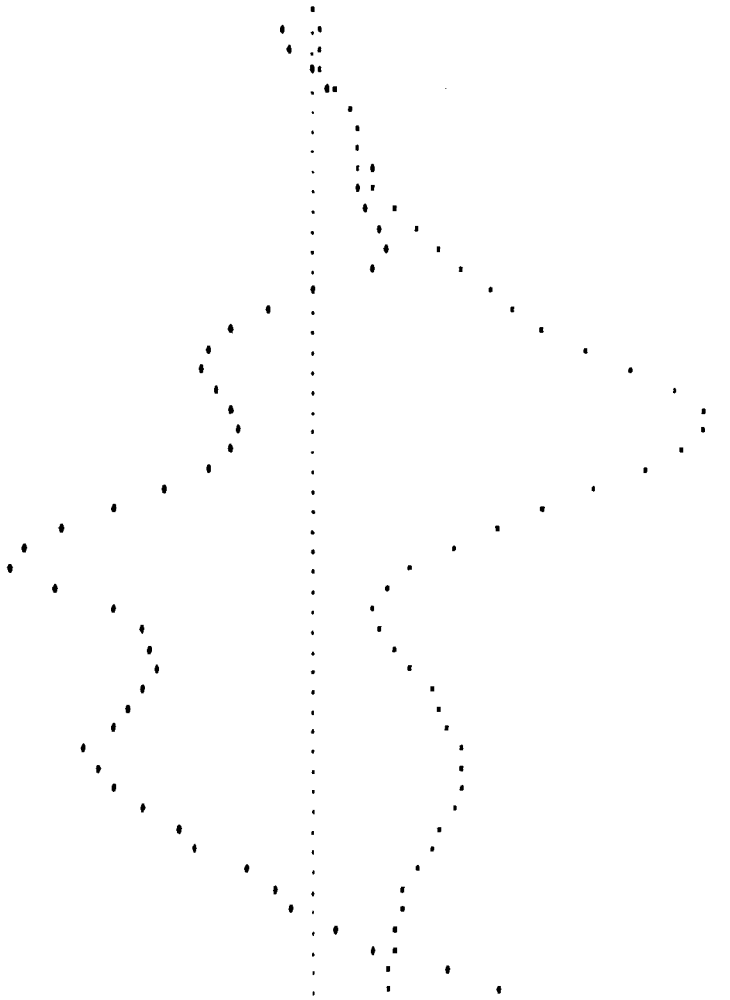

TIME (SEC)	FORCES APPLIED TO SEAT BY OCCUPANT					
	SEAT CUSHION (LS)			BACK CUSHION (LS)		
	FBC(1)	FBC(2)	FBC(3)	FBC(1)	FBC(2)	FBC(3)
.000	130.77	0.00	0.00	0.00	.00	0.00
.005	134.32	0.00	0.00	.00	0.00	0.00
.012	128.75	0.00	0.00	-.01	0.00	0.00
.018	124.81	0.00	0.00	0.00	0.00	0.00
.025	124.81	0.00	0.00	0.00	0.00	0.00
.030	127.85	0.00	0.00	0.00	0.00	0.00
.038	133.83	0.00	0.00	0.00	0.00	0.00
.042	143.81	0.00	0.00	0.00	0.00	0.00
.048	181.48	0.00	0.00	0.00	0.00	0.00
.054	183.78	0.00	0.00	0.00	0.00	0.00
.060	247.18	0.00	0.00	0.00	0.00	0.00
.068	323.72	0.00	0.00	7.00	0.00	0.00
.072	439.15	0.00	0.00	0.00	0.00	0.00
.078	811.81	0.00	0.00	0.00	0.00	0.00
.084	808.78	0.00	0.00	0.00	0.00	0.00
.087	1021.82	0.00	0.00	0.00	0.00	0.00
.088	1222.79	19.85	19.85	0.00	0.00	0.00
.102	1277.84	29.19	29.19	0.00	0.00	0.00
.108	1488.27	23.23	23.23	0.00	0.00	0.00
.114	1488.00	28.18	28.18	0.00	0.00	0.00
.120	1441.82	22.38	22.38	0.00	0.00	0.00
.128	1331.98	14.88	14.88	0.00	0.00	0.00
.132	1188.48	4.97	4.97	0.00	0.00	0.00
.138	1838.88	0.00	0.00	0.00	0.00	0.00
.144	818.78	0.00	0.00	0.00	0.00	0.00
.150	814.41	0.00	0.00	0.00	0.00	0.00
.158	743.25	0.00	0.00	0.00	0.00	0.00
.162	783.83	0.00	0.00	0.00	0.00	0.00
.168	881.88	0.00	0.00	0.00	0.00	0.00
.174	883.88	0.00	0.00	0.00	0.00	0.00
.180	788.87	0.00	0.00	0.00	0.00	0.00
.188	723.84	0.00	0.00	0.00	0.00	0.00
.192	788.85	0.00	0.00	0.00	0.00	0.00
.198	788.74	0.00	0.00	0.00	0.00	0.00
.204	814.14	0.00	0.00	0.00	0.00	0.00
.210	818.32	0.00	0.00	0.00	0.00	0.00
.218	891.54	0.00	0.00	0.00	0.00	0.00
.222	774.88	0.00	0.00	0.00	0.00	0.00
.228	728.84	0.00	0.00	0.00	0.00	0.00
.234	883.87	0.00	0.00	0.00	0.00	0.00
.240	848.88	0.00	0.00	0.00	0.00	0.00
.248	882.84	0.00	0.00	0.00	0.00	0.00
.252	328.88	0.00	0.00	0.00	0.00	0.00
.258	328.84	0.00	0.00	0.00	0.00	0.00
.264	491.88	0.00	0.00	0.00	0.00	0.00
.270	471.88	0.00	0.00	0.00	0.00	0.00
.278	484.28	0.00	0.00	0.00	0.00	0.00
.282	487.87	0.00	0.00	0.00	0.00	0.00
.288	478.48	0.00	0.00	0.00	0.00	0.00
.294	488.82	0.00	0.00	0.00	0.00	0.00

TIME (SEC)	FRAMES BETWEEN FEET AND FLOOR					
	RIGHT			LEFT		
	X	Y	Z	X	Y	Z
.000	0.00	0.00	.00	0.00	0.00	.00
.006	.02	0.00	12.00	.02	0.00	12.00
.012	1.27	0.00	22.20	1.27	0.00	22.20
.018	-3.00	0.00	21.13	-3.00	0.00	21.13
.025	-3.02	0.00	23.27	-3.02	0.00	23.27
.030	-8.00	0.00	27.20	-8.00	0.00	27.20
.036	-8.00	0.00	27.22	-8.00	0.00	27.22
.042	-4.04	0.00	18.17	-4.04	0.00	18.17
.048	-1.54	0.00	2.15	-1.54	0.00	2.15
.054	0.00	0.00	0.00	0.00	0.00	0.00
.060	0.00	0.00	0.00	0.00	0.00	0.00
.066	0.00	0.00	0.00	0.00	0.00	0.00
.072	0.00	0.00	0.00	0.00	0.00	0.00
.078	0.00	0.00	0.00	0.00	0.00	0.00
.084	0.00	0.00	0.00	0.00	0.00	0.00
.090	0.00	0.00	0.00	0.00	0.00	0.00
.096	0.00	0.00	0.00	0.00	0.00	0.00
.102	0.00	0.00	0.00	0.00	0.00	0.00
.108	0.00	0.00	0.00	0.00	0.00	0.00
.114	0.00	0.00	0.00	0.00	0.00	0.00
.120	0.00	0.00	0.00	0.00	0.00	0.00
.126	0.00	0.00	0.00	0.00	0.00	0.00
.132	0.00	0.00	0.00	0.00	0.00	0.00
.138	0.00	0.00	0.00	0.00	0.00	0.00
.144	0.00	0.00	0.00	0.00	0.00	0.00
.150	0.00	0.00	0.00	0.00	0.00	0.00
.156	0.00	0.00	0.00	0.00	0.00	0.00
.162	0.00	0.00	0.00	0.00	0.00	0.00
.168	0.00	0.00	0.00	0.00	0.00	0.00
.174	0.00	0.00	0.00	0.00	0.00	0.00
.180	0.00	0.00	0.00	0.00	0.00	0.00
.186	0.00	0.00	0.00	0.00	0.00	0.00
.192	0.00	0.00	0.00	0.00	0.00	0.00
.198	0.00	0.00	0.00	0.00	0.00	0.00
.204	0.00	0.00	0.00	0.00	0.00	0.00
.210	0.00	0.00	0.00	0.00	0.00	0.00
.216	0.00	0.00	0.00	0.00	0.00	0.00
.222	0.00	0.00	0.00	0.00	0.00	0.00
.228	0.00	0.00	0.00	0.00	0.00	0.00
.234	0.00	0.00	0.00	0.00	0.00	0.00
.240	0.00	0.00	0.00	0.00	0.00	0.00
.246	0.00	0.00	0.00	0.00	0.00	0.00
.252	0.00	0.00	0.00	0.00	0.00	0.00
.258	0.00	0.00	0.00	0.00	0.00	0.00
.264	0.00	0.00	0.00	0.00	0.00	0.00
.270	0.00	0.00	0.00	0.00	0.00	0.00
.276	0.00	0.00	0.00	0.00	0.00	0.00
.282	0.00	0.00	0.00	0.00	0.00	0.00
.288	0.00	0.00	0.00	0.00	0.00	0.00
.294	0.00	0.00	0.00	0.00	0.00	0.00

AIRCRAFT DISPLACEMENT

TIME (SEC)	X (IN)	Y (IN)	Z (IN)
0.000	0.00	0.00	0.00
.006	3.18	0.00	0.00
.012	6.36	0.00	0.00
.018	9.54	0.00	0.00
.025	12.72	0.00	0.00
.030	15.90	0.00	0.00
.036	19.08	0.00	0.00
.042	22.26	0.00	0.00
.048	25.44	0.00	0.00
.054	28.62	0.00	0.00
.060	31.80	0.00	0.00
.072	34.98	0.00	0.00
.078	38.16	0.00	0.00
.084	41.34	0.00	0.00
.090	44.52	0.00	0.00
.096	47.70	0.00	0.00
.102	50.88	0.00	0.00
.108	54.06	0.00	0.00
.114	57.24	0.00	0.00
.120	60.42	0.00	0.00
.126	63.60	0.00	0.00
.132	66.78	0.00	0.00
.138	69.96	0.00	0.00
.144	73.14	0.00	0.00
.150	76.32	0.00	0.00
.156	79.50	0.00	0.00
.162	82.68	0.00	0.00
.168	85.86	0.00	0.00
.174	89.04	0.00	0.00
.180	92.22	0.00	0.00
.186	95.40	0.00	0.00
.192	98.58	0.00	0.00
.198	101.76	0.00	0.00
.204	104.94	0.00	0.00
.210	108.12	0.00	0.00
.216	111.30	0.00	0.00
.222	114.48	0.00	0.00
.228	117.66	0.00	0.00
.234	120.84	0.00	0.00
.240	124.02	0.00	0.00
.246	127.20	0.00	0.00
.252	130.38	0.00	0.00
.258	133.56	0.00	0.00
.264	136.74	0.00	0.00
.270	139.92	0.00	0.00
.276	143.10	0.00	0.00
.282	146.28	0.00	0.00
.288	149.46	0.00	0.00
.294	152.64	0.00	0.00

SCALE FACTOR = .004E+01

ALPDRIFT VELOCITY

TIME (SEC)	X (FPS)	Y (FPS)	Z (FPS)
0.000	44.10	0.00	0.00
.005	44.17	0.00	0.00
.010	44.04	0.00	0.00
.015	43.42	0.00	0.00
.020	42.62	0.00	0.00
.025	41.67	0.00	0.00
.030	40.35	0.00	0.00
.035	38.52	0.00	0.00
.040	36.40	0.00	0.00
.045	34.27	0.00	0.00
.050	32.10	0.00	0.00
.055	30.03	0.00	0.00
.060	28.03	0.00	0.00
.065	26.08	0.00	0.00
.070	24.28	0.00	0.00
.075	22.51	0.00	0.00
.080	20.77	0.00	0.00
.085	19.06	0.00	0.00
.090	17.38	0.00	0.00
.095	15.71	0.00	0.00
.100	14.06	0.00	0.00
.105	12.43	0.00	0.00
.110	10.81	0.00	0.00
.115	9.20	0.00	0.00
.120	7.60	0.00	0.00
.125	6.01	0.00	0.00
.130	4.43	0.00	0.00
.135	2.85	0.00	0.00
.140	1.28	0.00	0.00
.145	-0.28	0.00	0.00
.150	-1.83	0.00	0.00
.155	-3.37	0.00	0.00
.160	-4.90	0.00	0.00
.165	-6.41	0.00	0.00
.170	-7.91	0.00	0.00
.175	-9.39	0.00	0.00
.180	-10.85	0.00	0.00
.185	-12.29	0.00	0.00
.190	-13.71	0.00	0.00
.195	-15.11	0.00	0.00
.200	-16.49	0.00	0.00
.205	-17.85	0.00	0.00
.210	-19.19	0.00	0.00
.215	-20.51	0.00	0.00
.220	-21.81	0.00	0.00
.225	-23.09	0.00	0.00
.230	-24.35	0.00	0.00
.235	-25.59	0.00	0.00
.240	-26.81	0.00	0.00
.245	-28.01	0.00	0.00
.250	-29.19	0.00	0.00
.255	-30.35	0.00	0.00
.260	-31.49	0.00	0.00
.265	-32.61	0.00	0.00
.270	-33.71	0.00	0.00
.275	-34.79	0.00	0.00
.280	-35.85	0.00	0.00
.285	-36.89	0.00	0.00
.290	-37.91	0.00	0.00
.295	-38.91	0.00	0.00
.300	-39.89	0.00	0.00
.305	-40.85	0.00	0.00
.310	-41.79	0.00	0.00
.315	-42.71	0.00	0.00
.320	-43.61	0.00	0.00
.325	-44.49	0.00	0.00
.330	-45.35	0.00	0.00
.335	-46.19	0.00	0.00
.340	-47.01	0.00	0.00
.345	-47.81	0.00	0.00
.350	-48.59	0.00	0.00
.355	-49.35	0.00	0.00
.360	-50.09	0.00	0.00
.365	-50.81	0.00	0.00
.370	-51.51	0.00	0.00
.375	-52.19	0.00	0.00
.380	-52.85	0.00	0.00
.385	-53.49	0.00	0.00
.390	-54.11	0.00	0.00
.395	-54.71	0.00	0.00
.400	-55.29	0.00	0.00
.405	-55.85	0.00	0.00
.410	-56.39	0.00	0.00
.415	-56.91	0.00	0.00
.420	-57.41	0.00	0.00
.425	-57.89	0.00	0.00
.430	-58.35	0.00	0.00
.435	-58.79	0.00	0.00
.440	-59.21	0.00	0.00
.445	-59.61	0.00	0.00
.450	-60.00	0.00	0.00
.455	-60.37	0.00	0.00
.460	-60.73	0.00	0.00
.465	-61.07	0.00	0.00
.470	-61.40	0.00	0.00
.475	-61.71	0.00	0.00
.480	-62.01	0.00	0.00
.485	-62.29	0.00	0.00
.490	-62.55	0.00	0.00
.495	-62.79	0.00	0.00
.500	-63.01	0.00	0.00

SCALE FACTOR = .330E+01

ALROCRPT ACCELERATION

TIME (SEC)	X (G)	Y (G)	Z (G)
0.000	0.00	0.00	0.00
.000	-1.12	0.00	0.00
.012	-1.71	0.00	0.00
.018	-4.05	0.00	0.00
.023	-4.18	0.00	0.00
.030	-5.77	0.00	0.00
.036	-5.88	0.00	0.00
.042	-5.38	0.00	0.00
.048	-6.10	0.00	0.00
.054	-5.83	0.00	0.00
.060	-5.78	0.00	0.00
.066	-6.04	0.00	0.00
.072	-5.38	0.00	0.00
.078	-5.74	0.00	0.00
.084	-5.44	0.00	0.00
.090	-5.44	0.00	0.00
.096	-5.44	0.00	0.00
.102	-5.44	0.00	0.00
.108	-5.44	0.00	0.00
.114	-5.44	0.00	0.00
.120	-5.44	0.00	0.00
.126	-5.44	0.00	0.00
.132	-5.44	0.00	0.00
.138	-5.44	0.00	0.00
.144	-5.44	0.00	0.00
.150	-5.44	0.00	0.00
.156	-5.44	0.00	0.00
.162	-5.44	0.00	0.00
.168	-5.44	0.00	0.00
.174	-5.44	0.00	0.00
.180	-5.44	0.00	0.00
.186	-5.44	0.00	0.00
.192	-5.44	0.00	0.00
.198	-5.44	0.00	0.00
.204	-5.44	0.00	0.00
.210	-5.44	0.00	0.00
.216	-5.44	0.00	0.00
.222	-5.44	0.00	0.00
.228	-5.44	0.00	0.00
.234	-5.44	0.00	0.00
.240	-5.44	0.00	0.00
.246	-5.44	0.00	0.00
.252	-5.44	0.00	0.00
.258	-5.44	0.00	0.00
.264	-4.83	0.00	0.00
.270	-2.81	0.00	0.00
.276	-1.88	0.00	0.00
.282	1.15	0.00	0.00
.288	1.00	0.00	0.00
.294	.83	0.00	0.00

SCALE FACTOR = .002E+00

FINAL GENERALIZED COORDINATES

J	Q1(J)	Q2(J)	Q3(J)
1	0.0000E+01	-5.2013E+01	-1.0000E+02
2	2.3210E+01	-2.7200E+00	1.0000E+02
3	-2.7200E+01	4.0000E-01	-0.0100E+01
4	1.0000E+01	-0.0007E-01	-1.1220E+00
5	-3.0777E-01	2.0023E+00	3.3520E+01
6	6.2240E+00	-1.7071E+00	-2.0070E+02
7	1.0040E+01	1.3210E+00	2.0000E+01
8	-1.2271E+00	1.2910E+00	1.0000E+02
9	-4.0000E-01	1.2300E+00	-2.0027E+01
10	-0.0010E+02	3.2100E-01	-1.2370E+00
11	-1.2310E+00	-2.3000E-01	2.3307E+02

APPENDIX D
PROGRAM STRUCTURE

The overall organization of Program SOM-LA is illustrated in figure D-1. The main program controls the overall solution procedure by calling two individual sets of subroutines, one for the occupant segments of the program, and the other for the seat segment of the program. Detailed descriptions of the occupant subroutines are presented in section D.1, and the seat subroutines in section D.2.

At the start of execution, the main program calls subroutine INPT to read input data for the occupant model and subroutine READIN for seat input data. Subroutines CONST and INITIL calculate constants and determine initial values of generalized coordinates for the occupant, and subroutine ASSBLE performs preliminary calculations for the seat model. Then, a solution loop is entered at initial time and passed through for each time step. During each pass through the solution loop, subroutine RKAM advances the solution for the occupant equations of motion one time step and provides forces to be applied to the seat model by the occupant. After the call to RKAM, if the finite element seat model is being used, subroutine SOLVE advances the solution by the seat structural analysis to the same point in time that has been attained by RKAM. At time intervals selected by user input, subroutine ANSWER stores, in arrays, user-selected items of output data. Data for post-processing plot programs are written on external files 14 and 20 for the occupant and seat, respectively. Additional data are written on unit 26, as described in section 3.4. These files must be saved if plots are desired.

D.1 OCCUPANT SUBROUTINE DESCRIPTIONS

The relationship among the subroutines in the occupant segment of the program are illustrated in figure D-2. Individual subroutines are described below.

D.1.1 Subroutine AMATRX. Called by EQUATE; calculates elements of the inertia matrix [A] for three-dimensional occupant model.

D.1.2 Subroutine AMATX2. Called by EQUAT2; calculates elements of inertia matrix for two-dimensional occupant model.

D.1.3 Subroutine ANSWER. Called by MAIN; calculates accelerations $AC(I, J)$ of body segments in the inertial coordinate system and transforms accelerations to segment-fixed coordinate systems. Calculates severity indices and organizes position, velocity, and force data for output. Writes plot data on units 14 and 26. If data filtering is requested by user input, ANSWER writes occupant accelerations on unit 9 and seat accelerations on unit 10 for subsequent filtering by subroutine OUTPT.

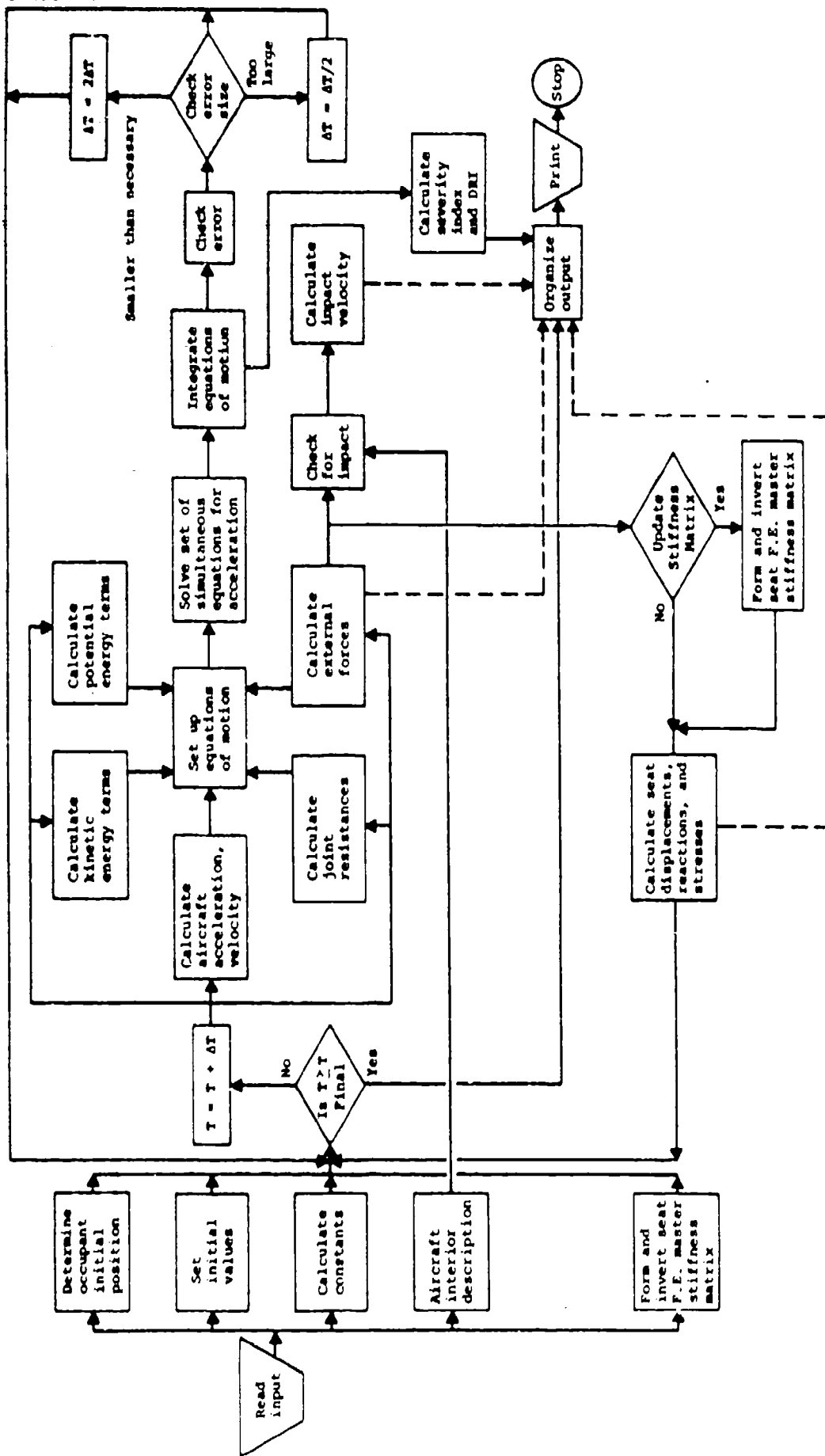

Figure D-1. Overall organization of Program SOM-LA.

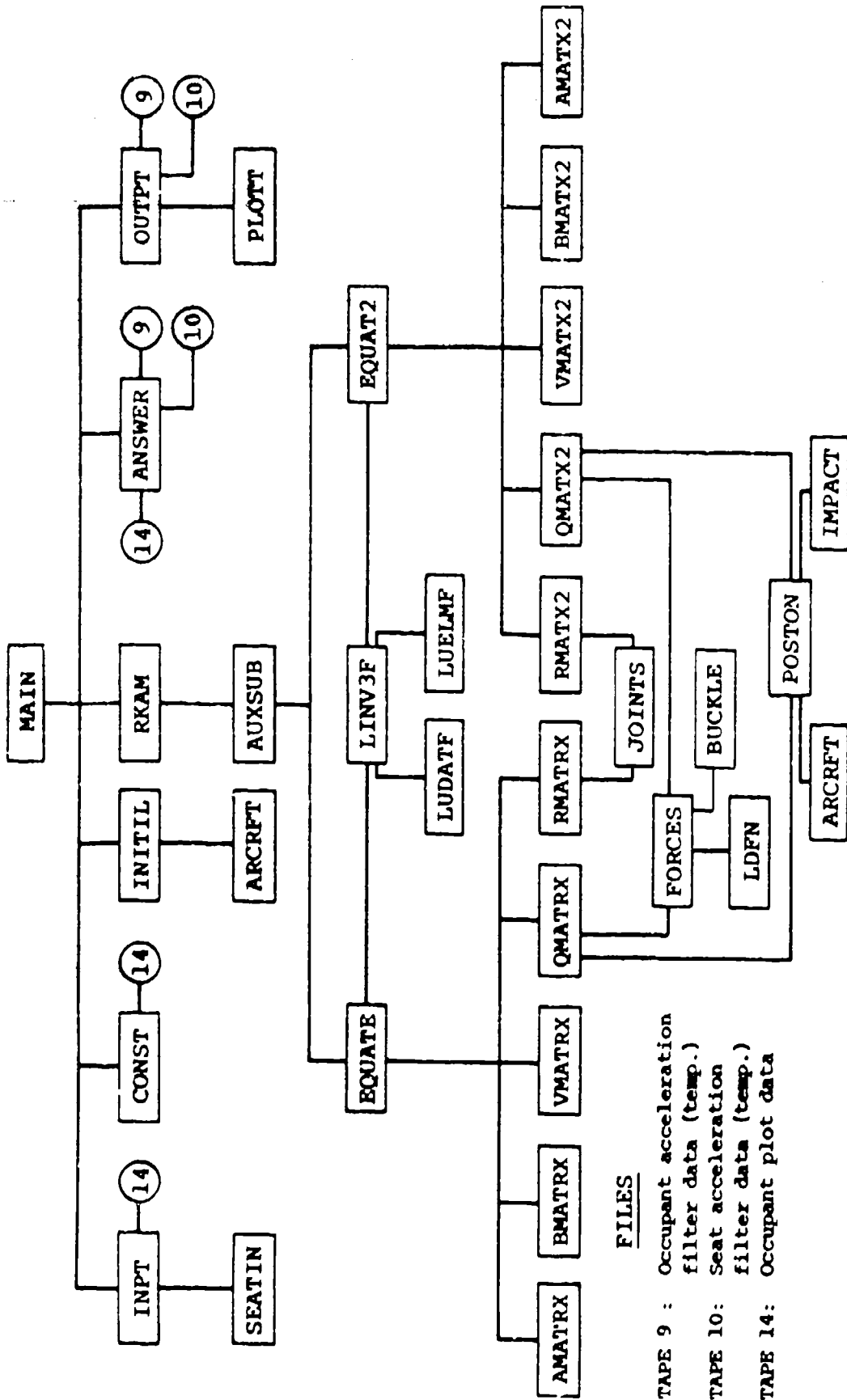

Figure D-2. SOM-LA Program Structure: Occupant Segment.

D.1.4 Subroutine ARCRFT. Called initially by INITIL, then by POSTON; calculates current acceleration components at aircraft floor (ACC(J), J = 1, 3) based on input acceleration pulses. Integrates acceleration to determine velocity (in aircraft coordinate system) and displacement (in inertial system). When time is greater than the input pulse duration, acceleration is set to zero, so that velocity then remains constant.

D.1.5 Subroutine AUXSUB. Called by RKAM (also initially by MAIN); calculates derivatives and forms two 1 x 2N arrays of variables and derivatives:

$$\begin{array}{ll}
 V(1) = Q(1) & DER(1) = QD(1) \\
 \cdot & \cdot \\
 \cdot & \cdot \\
 \cdot & \cdot \\
 V(N) = Q(N) & DER(N) = QD(N) \\
 V(N+1) = QD(1) & DER(N+1) = QDD(1) \\
 \cdot & \cdot \\
 \cdot & \cdot \\
 \cdot & \cdot \\
 V(2N) = QD(N) & DER(2N) = QDD(N)
 \end{array}$$

where N is the number of degrees of freedom, either 12 for the two-dimensional model or 29 for the three-dimensional model. The velocity and acceleration of the DRI model are assigned to DER(2N+1) and DER (2N+2), respectively. If the two-degree-of-freedom energy-absorbing seat model is used, its velocities and accelerations are assigned to DER(2N+3) through DER(2N+6).

EQUATE is called to provide values of the derivatives (the generalized velocities, QD(J), and accelerations QDD(J)). RKAM then integrates the two systems of first-order equations.

D.1.6 Subroutine BMATRX. Called by EQUATE; calculates elements of velocity-dependent vector {B} for three-dimensional model.

D.1.7 Subroutine BMATX2. Called by EQUAT2; calculates elements of vector {B} for two-dimensional model.

D.1.8 Subroutine BUCKLE. Called by FORCES; determines position of point of intersection between abdominal contact surface and thigh contact surfaces (projected on X-Z plane).

D.1.9 Subroutine CONST. Called by MAIN; based on input data, calculates values of parameters that remain constant throughout program execution. These constants include functions of occupant dimensions used in the equations of motion and the following:

- Joint resistance parameters
- Aircraft cabin geometry
- Aircraft transformation matrix elements.

CONST also writes occupant dimensions on unit 14 for plotting.

D.1.10 Subroutine EQUATE. Called by AUXSUB for the three-dimensional occupant; uses latest values of generalized coordinates and velocities to calculate terms in occupant equations of motion. Solves equations of motion for accelerations QDD(J).

Calls AMATRIX, BMATRIX, VMATRIX, RMATRIX, AND QMATRIX in setting up the equations of motion and calls LINV3F for their solution.

D.1.11 Subroutine EQUAT2. Called by AUXSUB for the two-dimensional occupant; uses latest values of generalized coordinates and velocities to calculate terms in occupant equations of motion. Solves equations of motion for accelerations QDD(J).

Calls AMATX2, BMATX2, VMATX2, RMATX2, and QMATX2 in setting up the equations of motion and calls LINV3F for their solution.

D.1.12 Subroutine FORCES. Called by QMATRIX or QMATX2; calculates forces exerted on occupant by restraint system, cushions, and floor. Calculates deflection of each cushion or restraint system components and passes deflection to subroutine LDFN for computation of force.

The forces of the floor and seat cushions include frictional components whose directions oppose the current velocity of the occupant with respect to the floor or cushion.

The forces are placed in an array (F(I, J), I = 1, 11, J = 1, 3) for use in QMATRIX or QMATX2.

If the two-degree-of-freedom energy-absorbing seat model is used, the translational and rotational accelerations are calculated.

D.1.13 Subroutine IMPACT. Called by FORCES; computes point of closest proximity between each contact surface on the occupant and each aircraft cabin surface. DELIMP(N,J) is the penetration of occupant surface N into cabin surface J. If DELIMP(N,J) \geq 0 the impact velocity VELIMP(N,J) is calculated.

D.1.14 Subroutine INITIL. Called by MAIN; calculates initial values of the generalized coordinates and velocities for the occupant and the initial deflections of the seat. INITIL first uses input values of GAM(J) to determine the position of the body segments 1 through 7. Based on the aircraft orientation, the occupant's weight is applied to the seat and restraint system, and the position of the lower torso segment (X_1, Y_1, Z_1) is determined.

From the X and Z coordinates of segment 1 (computed here) and of the occupant's heels (from INPT) the position of the leg segments is calculated. Throughout these computations, the body is assumed to be symmetric with respect to the aircraft (X-Z) plane.

In the event that the input initial conditions impose unreasonable requirements on occupant geometry, a diagnostic message is provided and execution is stopped.

D.1.15 Subroutine INPT. Called by MAIN; reads occupant input data. A detailed description of input is presented in chapter 2 and appendix A.

D.1.16 Subroutine JOINTS. Called by RMATRX or RMATX2; fits a cubic curve into the transition region of the joint stopping moments.

D.1.17 Subroutine LDPN. Called by FORCES; uses linear interpolation in a table of force (Y) versus deflection (X) values. A description of the parameters in the calling sequence follows:

X	a table of the independent variable, x_i , such that $x_{i+1} \geq x_i$ (if II = 0)
Y	the table of the dependent variable, $y_i = y(x_i)$ (if II = 0)
N	the number of entries in each of the above tables; $i = 1, \dots, N$
XA	the independent variable, x , for which interpolation is requested
XLAST YLAST	previous values of XA and YA
ICLK	index which is 0 or 1 depending on call during loading or unloading
XCURV YCURV	point on loading curve from which unloading started
C	unloading slope, used only if IUNLD = 2.
YA	the dependent variable, $y = y(x)$, being determined
IUNLD	index which is 2 if unloading slope, C, is to be used, 1 if unloading proceeds along basic loading function.

D.1.18 Subroutine LINV3F. Performs matrix decomposition, matrix inversion, linear equation solution, and determinant evaluation:

- A Input/output matrix of dimensions $N \times N$. See parameter IJOB.
- B Input/output vector of length N when IJOB = 2 or 3. On input, B contains the right-hand side of the equation $AX = B$. On output, the solution X replaces B. Otherwise, B is not used.
- IJOB Input option parameter. IJOB = I implies when
 I = 1, invert matrix A. A is replaced by its inverse.
 I = 2, solve the equation $AX = B$. A is replaced by the LU decomposition of a rowwise permutation of A, where U is upper triangular and L is lower triangular with unit diagonal. The unit diagonal of L is not stored.
 I = 3, solve $AX = B$ and invert matrix A. A is replaced by its inverse.
 I = 4, compute the determinant of A. A is replaced by the LU decomposition of a rowwise permutation of A.
- N Order of A. (input)
- IA Row dimension of A as specified in the calling program. IA must be greater than or equal to N. (input)
- D1,D2 If D1 is non-negative on input, then D1 and D2 will be components of the determinant on output such that $\text{determinant}(A) = D1^2 * D2$.
- WKAREA Work area of length at least $2*N$ when IJOB = 1 or 3. Work area of length at least N when IJOB = 2 or 4.
- IER Error parameter.
 Warning with $\text{fix} = 64+N$.
 N = 1 indicates that IJOB was less than 1 or greater than 4. IJOB is assumed to be 4.
 Terminal error = $128+N$.
 N = 2 indicates that matrix A is algorithmically singular.

D.1.19 Subroutine LUDATF. Performs L-U decomposition by the Crout algorithm with optional accuracy test.

- A Input matrix of dimension $N \times N$ containing the matrix to be decomposed.
- LU Real output matrix of dimension $N \times N$ containing the L-U decomposition of a rowwise permutation of the input matrix.

N Input scalar containing the order of the matrix A.

IA Input scalar containing the row dimension of matrices A and LU in the calling program.

IDGT Input option.
 If IDGT is greater than zero, the non-zero elements of A are assumed to be correct to IDGT decimal places. LUDATF performs an accuracy test to determine if the computed decomposition is the exact decomposition of a matrix which differs from the given one by less than its uncertainty.

 If IDGT is equal to zero, the accuracy test is bypassed.

D1 Output scalar containing one of the two components of the determinant. See description of parameter D2, below.

D2 Output scalar containing one of the two components of the determinant. The determinant may be evaluated as $(D1)(2**D2)$.

IPVT Output vector of length N containing the permutation indices.

EQUIL Output vector of length N containing reciprocals of the absolute values of the largest (in absolute value) element in each row.

WA Accuracy test parameter, output only if IDGT is greater than zero. See element documentation for details.

IER Error parameter.
 Terminal error = $128+N$
 N = 1 indicates that matrix A is algorithmically singular.
 Warning error = $32+N$
 N = 2 indicates that the accuracy test failed. The computed solution may be in error by more than can be accounted for by the uncertainty of the data. This warning can be produced only if IDGT is greater than 0 on input.

D.1.20 Subroutine LUELMF. Performs elimination part of solution of $AX = B$, in full-storage mode

- A The result, LU, computed in the subroutine LUDATF, where L is a lower triangular matrix with ones on the main diagonal. Y is upper triangular. L and U are stored as a single matrix A, and the unit diagonal of L is not stored.
- B B is a vector of length N on the right-hand side of the equation AX = B.
- IPVT The permutation matrix returned from the subroutine LUDATF, stored as an N length vector.
- N Order of A and number of rows in B.
- IA Number of rows in the dimension statement for A in the calling program.
- X The result X.

D.1.21 Subroutine OUTPT. Called by MAIN; writes output data, along with headings, on output file. The parameter IOOUT(J) from input determines whether the output file receives data of Type J. For example, output category no. 1 is occupant segment position information. If IOOUT(1) = 1, these data go to output; if IOOUT(1) = 0, they do not. Also performs filtering of acceleration data if requested in input.

D.1.22 Subroutine PLOTT. Provides printer plots for up to three dependent, continuous, single-valued functions (Y1, Y2, Y3) against an even-incremental independent variable (X).

- M The number of dependent variables (1, 2, or 3).
- NP The number of points to be plotted for each dependent variable.
- X The independent variable.
- Y1 The dependent variables.
Y2
Y3

D.1.23 Subroutine POSTON. Called by QMATRX or QMATX2; uses equations of the form

$$\begin{Bmatrix} X \\ Y \\ Z \end{Bmatrix} = \begin{bmatrix} T^n \end{bmatrix} \begin{Bmatrix} x_n \\ y_n \\ z_n \end{Bmatrix}$$

to compute absolute positions of 29 points on body (XC, YC, ZC). Computes positions of same 29 points in aircraft coordinate system (XCA, YCA, ZCA). Calculates velocities (XCDA, YCDA, ZCDA) for output.

D.1.24 Subroutine QMATRX. Called by EQUATE for three-dimensional model; calculates elements of generalized force vector $\{Q_f\}$. Calls FORCES for computation of external forces acting on occupant.

D.1.25 Subroutine QMATX2. Called by EQUAT2 for two-dimensional model; calculates elements of generalized force vector $\{Q_f\}$. Calls FORCES for computation of external forces acting on occupant.

D.1.26 Subroutine RKAM. Called by MAIN; solves a set of N simultaneous, first-order, ordinary differential equations. Because of the importance of the integration scheme to the success of any dynamic analysis program, a detailed discussion of the method is provided along with the description of the FORTRAN subroutine.

Method - The user is allowed an option of using either the Runge-Kutta classical fourth-order method or the Adams-Moulton predictor-corrector method using the Runge-Kutta method for starting the process.

The system of equations to be solved is:

$$y_i' = f_i(x, y_1, y_2, \dots, y_N) \quad i = 1, 2, \dots, N \quad (D.1)$$

$$y_i(x_0) = y_{i0}$$

Let y_{in} be the value of y_i at $x = x_n$ and f_{in} the derivative of y_i at $x = x_n$, and let h be the increment (step size) of the independent variable x . The classical Runge-Kutta fourth-order method uses the formulas

$$\begin{aligned} k_{i1} &= hf_i(x_n, y_{in}), \\ k_{i2} &= hf_i(x_n + \frac{1}{2}h, y_{in} + \frac{1}{2}k_{i1}), \\ k_{i3} &= hf_i(x_n + \frac{1}{2}h, y_{in} + \frac{1}{2}k_{i2}), \\ k_{i4} &= hf_i(x_n + h, y_{in} + k_{i3}), \end{aligned} \quad (D.2)$$

$$y_{i,n+1} = y_n + \frac{1}{6} (k_{i1} + 2k_{i2} + 2k_{i3} + k_{i4})$$

The normal option is to continue the integration with Adams-Moulton predictor-corrector formulas once enough back values have been generated by the Runge-Kutta method.

The Adams-Moulton predictor-corrector formulas for the system (D.1) are

$$y_{i,n+1}^{(p)} = y_{i,n} + \frac{h}{24} (55f_{i,n} - 59f_{i,n-1} + 37f_{i,n-2} - 9f_{i,n-3}) \quad (D.3)$$

$$y_{i,n+1}^{(c)} = y_{i,n} + \frac{h}{24} (9f_{i,n+1}^{(p)} + 19f_{i,n} - 5f_{i,n-1} + f_{i,n-2}) \quad (D.4)$$

The corrector formula (D.4) is applied only once so that only two derivative evaluations are needed for each Adams-Moulton integration step. The starting values needed in (D.3) are obtained using the Runge-Kutta method.

The Adams-Moulton method may be used with either a fixed step size or a variable step size. The step size to be used in the variable mode is determined from the difference between the predicted and corrected values. The integration step size is thus controlled dynamically between prescribed error bounds so that execution speed and accuracy can be optimized.

Restrictions - An auxiliary routine must be provided for evaluation of the first-order derivatives. (See AUXSUB under Calling Sequence.)

Initial conditions for both variables and derivatives must be stored in their respective locations prior to entering RKAM.

Calling Sequence

XDP	=	x, the independent variable
HDP	=	h, the integration step size
VAR	=	N-dimensional vector of dependent variables (Y ₁ , Y ₂ , ..., Y _N)
DER	=	N-dimensional vector of derivatives (Y ₁ ' , Y ₂ ' , ..., Y _N ')
AUXSUB	=	Name of the auxiliary routine that computes derivatives and stores them in DER (1) to DER(N). The main program, which calls RKAM, must contain an EXTERNAL statement. No items are allowed in the calling sequence.
N	=	Number of equations

OPT	=	Option indicator, zero for AM, non-zero for RK only
EU	=	N-dimensional vector of upper bounds from main program
EL	=	N-dimensional vector of lower bounds from main program
HMAX	=	Absolute value of maximum allowable step size
HMIN	=	Absolute value of minimum allowable step size (HMIN > 0).
ICNT	=	Internal counter, set to zero initially in MAIN
TEMPS	=	A two-dimensional, (9,N) storage region. TEMP (1,I), I = 1, N must be set to zero initially or when restarting.
NH	=	Index of the equation that caused halving when step size has been reduced.

VAR, DER, and all other locations referred to in both the main program and the auxiliary subroutine must be assigned in COMMON statements. (If the step size were to be changed outside of RKAM, the restart flag, ICNT, should be set to zero.) This restriction does not apply in the "RK only" mode. HMAX, HMIN, EU, and EL are also irrelevant in this mode.

Functional Description - The subroutine employs the fourth-order Adams-Moulton predictor-corrector method using the classical fourth-order Runge-Kutta method to obtain starting values.

AM has the following advantages with respect to RK:

1. Only half as many derivative evaluations per integration step are required to attain the same order of accuracy.
2. The local truncation error may be estimated at the conclusion of each integration step thereby providing a means for step size control.

For each variable, the local truncation error is approximately one-fourteenth the difference between the predicted and corrected values, that is

$$e_i = \frac{1}{14} | y_i^{(c)} - y_i^{(p)} | \quad (D.5)$$

In RKAM, the differences $D_i \equiv |y_i^{(c)} - y_i^{(p)}|$ are formed and compared with positive numbers EU_i and EL_i . If $D_i > EU_i$ for any i , the step size is halved provided $|h/2|_i > HMIN_i$. If $D_i < EL_i$ for all i and for three successive steps, the step size is doubled provided $|2h| < HMAX$. (Note that h may be held fixed either by setting $HMIN = HMAX$ or by making EU_i and EL_i prohibitively large and small, respectively.) If halving is called for during the first AM step following the three initial RK steps, the step size is halved, the independent variable is set back to its initial value, and the three RK steps are repeated. This will continue until the first AM step is successfully taken. From this point on, halving is effected by interpolation of past data whereas doubling is accomplished by alternate selection of past data.

In selecting EU and EL , one should note the following:

1. The test is an absolute test. To control relative error EU_i and EL_i should be computed as functions of y_i prior to each integration step.
2. Although the local truncation error in y_i is not allowed to exceed EU_i , this does not imply that the cumulative error will not exceed EU_i . Therefore, EU_i and EL_i should depend upon the maximum allowable cumulative error and the number of integration steps.
3. Since doubling h will multiply the truncation error by a factor of 2^5 , EL_i should be chosen less than $EU_i/32$ if the advantages of doubling are not to be short-lived.

D.1.27 Subroutine RMATRIX. Called by EQUATE for three-dimensional model; calculates elements of joint resistance vector $\{R\}$. Input parameter IMAN determines whether human (IMAN = 0) or dummy (IMAN = 1) model is used.

D.1.28 Subroutine RMATX2. Called by EQUAT2 for two-dimensional model; calculates elements of joint resistance vector $\{R\}$.

D.1.29 Subroutine SEATIN. Called by INPT if NSEAT = 0; reads input data required for rigid seat model and energy-absorbing option.

D.1.30 Subroutine VMATRIX. Called by EQUATE for three-dimensional model; calculates elements of force vector $\{F_p\}$ derived from system potential energy.

D.1.31 Subroutine VMATX2. Called by EQUAT2 for two-dimensional model; calculates elements of force vector $\{F_p\}$ derived from system potential energy.

D.2 SEAT SUBROUTINE DESCRIPTIONS

The relationships among the subroutines in the seat segment of the program are illustrated in figure D-3. Individual subroutines are described below.

D.2.1 Subroutine ASSBLE. Called by MAIN; initializes the element data storage. The mass matrix and the initial transformations \underline{B}_0 for the nodal coordinate systems are assembled, and the initial values of the pointing vectors \bar{n} , $\bar{\pi}$, and $\bar{\xi}$ and the normal components of the rigid links $\bar{\Delta}$ are generated.

D.2.2 Subroutine ASSMBL. Called by PLSTF and BMSTF; assembles the master stiffness matrix in a banded symmetric form. This subroutine calls subroutine KADD, which adds a particular element of the square element stiffness matrix to the banded master stiffness matrix.

D.2.3 Subroutine BASME. Called by ASSBLE; calculates the contributions to the lumped mass matrix for beam elements and forms the initial element coordinate system \underline{E} for beam and spring elements.

D.2.4 Subroutine BFRCIN. Called by FRCIN; calculates the beam and spring element deformations and nodal forces in the element coordinate system. Performs the operations associated with the master-slave relations and transforms the forces to the nodal coordinate system.

D.2.5 Subroutine BGEOM. Called by READIN; reads the data describing the cross-section properties of beams and springs. Generates certain additional data, such as segment lengths and torsional constants.

D.2.6 Subroutine BMEND. Called by BMSTF; calls MODK to calculate the reduced stiffness matrix due to axial force, shear, and moment discontinuity.

D.2.7 Subroutine BMSTF. Called by SOLVE; calculates beam or spring element stiffness matrix. The principal subroutines called include BMSTF1 for elastic material, BMSTF2 for inelastic material, BMEND for the modification of the stiffness due to special end conditions, and ASSMBL for assembly of element stiffness.

D.2.8 Subroutine BMSTF2. Called by BMSTF; calculates the elastic stiffness matrix for a beam or spring element.

D.2.9 Subroutine BMSTF2. Called by BMSTF; calculates the tangential stiffness matrix for a beam or spring element.

D.2.10 Subroutine BOUND. Called by SOLVE; applies the specified boundary conditions to the assembled master stiffness matrix by calling ZERORC, which deletes the appropriate rows and columns of the banded matrix.

- D.2.11 Subroutine CROSS. Utility subroutine; calculates the cross product of two matrices.
- D.2.12 Subroutine CRVTBL. Called by EPTSTF; contains plate bending curvature tables.
- D.2.13 Subroutine CURVAT. Called by TFRGIN; provides algebraic expressions for curvature components at the midpoints of the three sides of the plate elements as functions of the nodal rotations.
- D.2.14 Subroutine DECOD. Utility subroutine, decodes a packed word.
- D.2.15 Subroutine EFFSTF. Called by SOLVE; generates the effective stiffness with a 3 x 3 rotational mass matrix. Calls KADD, which adds a particular element of the square matrix to the banded matrix.
- D.2.16 Subroutine EPTSTF. Called by PLSTF; calculates plate element stiffness matrix. This subroutine calls TRIANG for the in-plane strain-displacement relationship, CRVTBL for curvature, and FORMK for calculation of appropriate elements in the stiffness matrix.
- D.2.17 Subroutine ETOG. Called by EPTSTF; transforms appropriate variables from the element coordinate system to the global coordinate system.
- D.2.18 Subroutine FORMK. Called by EPTSTF; calculates the products of three different matrices.
- D.2.19 Subroutine FRCIN. Called by SOLVE; calculates internal nodal forces. The program updates the nodal coordinate transformations B, and calls subroutines TFRGIN for plate forces and BFRGIN for beam forces.
- D.2.20 Subroutine FREEFD. Called by SOLVE; calculates the external forces including restraint system forces and forces exerted by the occupants on the seat pan and seat back.
- D.2.21 Subroutine GENFBM. Called by LOCFRC; numerically integrates stresses over the cross section of the beam to obtain internal forces and moments.
- D.2.22 Subroutines GENFO1/GENFO2. Called by TFRGIN; computes moments and forces at a cross section of an elastic-plastic plate (with/without) integrating through the thickness
- D.2.23 Subroutine GMPRD. Utility subroutine; performs general matrix multiplication.
- D.2.24 Subroutine CMTPRD. Utility subroutine; calculates the product of a matrix with the transpose of another matrix.

D.2.25 Subroutine GTPRD. Utility subroutine; calculates the product of the transpose of a matrix with another matrix.

D.2.26 Subroutine INCODE. Utility subroutine; encodes a number into a packed word.

D.2.27 Subroutine KADD. Called by ASSMBL and EFFSTF; adds a particular element of the square matrix to the banded matrix.

D.2.28 Subroutine LOCFRC. Called by BFCIN; calculates midplane strains, curvatures, nodal forces, and moments in the beam element coordinate system. Elongation and nodal forces are also calculated for the spring in the element coordinate system.

D.2.29 Subroutine LOCSB. Called by ASSMBL; computes the location of a particular element of a square matrix when assembled into the banded symmetric form.

D.2.30 Subroutine MCHB. Called by SOLVE; solves the linear system of equations $\underline{K} \underline{X} = \underline{F}$ for \underline{x} (displacements). The master stiffness matrix \underline{K} is assumed to be symmetric positive definite and stored in the compressed form, that is, main diagonal and upper codiagonals rowwise in successive storage locations. \underline{F} is the applied force vector. This is a two-step equation solver that uses Cholesky's method. In the first step the master stiffness matrix \underline{K} is factored into an upper diagonal matrix \underline{U} and a lower diagonal matrix \underline{L} .

$$\underline{K} = \underline{L} \underline{U} \quad (D.6)$$

and let

$$\underline{U} \bar{\underline{x}} = \bar{\underline{v}} \quad (D.7)$$

so that the linear system of equations $\underline{K} \bar{\underline{x}} = \bar{\underline{F}}$ is equivalent to

$$\underline{L} \bar{\underline{v}} = \bar{\underline{F}} \quad (D.8)$$

In the second step, equation (D.8) is solved by forward reduction for $\bar{\underline{v}}$ and finally equation (D.7) is solved for $\bar{\underline{x}}$ by back substituting for $\bar{\underline{v}}$.

D.2.31 Subroutines MISES1/MISES2. Called by TFCIN; computes biaxial elastic-plastic stress-strain relations using Von Mises yield criterion.

D.2.32 Subroutine MODIFY. Called by SOLVE; modifies forces to account for specified displacements.

D.2.33 Subroutine MODK. Called by BMEND; modifies beam element stiffness matrix and forces and moments for specified beam end conditions.

D.2.34 Subroutine NTOG. Called by PLSTF and BMSTF; transforms appropriate variables from global coordinate system to nodal coordinate system.

D.2.35 Subroutine OUTPUT. Called by SOLVE; organizes and tabulates output for those quantities selected for output. Deformed seat model plot data are written onto file 20 at user-selected times.

D.2.36 Subroutine PLSTF. Called by SOLVE; calls EPTSTF to form the plate element stiffness matrix and then uses ASSMBL to assemble the element stiffness.

D.2.37 Subroutine QUAD. Called by TASME; provides an algorithm for lumping the plate rotational inertia at the three defining nodes based on the properties of three quadrilaterals formed in the triangle by extending perpendiculars from the centroid to three sides.

D.2.38 Subroutine READIN. Called by MAIN; reads all input data and, if required, initializes the data files. Undeformed seat model data and model parameters are written onto file 20 if requested.

D.2.39 Subroutine RESTRT. Called by SOLVE; generates checkpoint data files or reads files that contain sufficient information to restart the solution procedures at specified times.

D.2.40 Subroutine SLTOMR. Called by BMSTF; transforms the appropriate variables from a slave node to the corresponding master node.

D.2.41 Subroutine SOLVE. Called by MAIN; performs the main solution procedure. The principal subroutines called are BMSTF for beam or spring stiffness, PLSTF for plate stiffness, FREEFD for applied forces, MCHB for the solution of displacements and OUTPUT for printed output and plot of selected parameters.

D.2.42 Subroutine SPRING. Called from LOCRFC; calculates element forces for a spring element.

D.2.43 Subroutine STRES. Called from GENFBM and SPRING; provides an algorithm for uniaxial stress-strain relationship.

D.2.44 Subroutine TASME. Called from ASSBLE; calculates the contributions to the lumped mass matrix for plate elements. Forms the initial element coordinate system E for the plate elements.

D.2.45 Subroutine TFCIN. Called from FRCIN; calculates plate element deformations and forces in element coordinate system. The forces are then transformed to the nodal coordinate system.

D.2.46 Subroutine TRIANG. Called from EPTSTF; contains algebraic expressions of the strain-displacement relationship for a plate element.

D.2.47 Subroutine VECTOR. Called from TFCIN; calculates the deformed length of plate element sides. The components of a vector normal to the reference surface are defined by the displaced positions of the three node points.

D.2.48 Subroutine ZERORC. Called from BOUND; deletes appropriate rows and columns of a banded matrix to enforce the specified boundary conditions.

APPENDIX E

OCCUPANT PLOTTING PROGRAM

```

PROGRAM DUMMY (INPUT,OUTPUT,TAPES,TAPES=OUTPUT,TAPE10)
C  UPDATED ON JULY 7, 1982
COMMON X(100),Z(100)
DIMENSION NPAN(4),NBAK(4)
DIMENSION XCA(84),YCA(84),ZCA(84),R(27),HEAD(6),P(84),
18(84),S(84),XLB(2),YLB(2),ZLB(2),XR(4),ZR(4),NTIME(2),ANGFT(2)
DIMENSION IRINDX(6),JINDX(17),KINDX(17),JJNDX(16),KKNDX(16)
DIMENSION JFNDX(7),KFNDX(7),NPINDX(17),XCAS(10),YCAS(10),ZCAS(10)
DIMENSION JLNDX(17),KLNDX(17)
DATA JLNDX/49,50,52,51,49,57,53,54,58,32,33,30,31,55,58,34,35/
DATA KLNDX/50,52,51,49,57,53,54,58,50,51,52,49,50,57,58,53,54/
DATA NPINDX/17*40/
DATA JFNDX,KFNDX/1,2,2,1,4,7,8,2,3,4,4,5,6,8/
DATA IRINDX/27,27,24,25,26,26/
DATA JINDX/18,24,27,18,20,18,21,16,12,17,13,61,62,29,25,18,19/
DATA KINDX/17,25,28,20,22,21,23,12,14,13,15,63,64,47,26,25,25/
DATA JJNDX/30,31,33,32,30,53,34,35,56,38,39,41,40,38,38,37/
DATA KKNDX/31,33,32,30,53,34,35,58,31,39,41,40,38,38,37,38/
DATA XCA,YCA,ZCA/180*0./
DATA XYFAC/.7/
READ(5,120)(HEAD(I),I=1,6),NCASE,IRSYS,ICKPT,NSEAT
120 FORMAT(BA10,4I5)
READ(5,130)(R(I),I=1,15)
130 FORMAT(BF10.0/7F10.0)
READ(5,100)R(24),R(25),R(26)
READ(5,100)THSCE,THBCE,THIRE
IF(ICKPT.EQ.0) GO TO 5
DO 4 J=1,10
READ(5,100)XCAS(J),YCAS(J),ZCAS(J)
4 CONTINUE
5 NP=1
500 READ(5,100)TIME,ALPHA,ANGFT(1),ANGFT(2)
READ(5,100)PL,PM,SBH,SBW,THEB,THEP,XSEAT,ZBEAT
READ(5,100)XLB(1),YLB(1),ZLB(1),XLB(2),YLB(2),ZLB(2),XFR,ANGFR
IF(IRSYS.GT.0) READ(5,100)XSH,YSH,ZSH
IF(IRSYS.EQ.4) READ(5,100)XCA(48),YCA(48),ZCA(48)
100 FORMAT (BF10.0)
READ(5,10)(XCA(J),J=1,28),(XCA(J),J=45,47),XCA(58),XCA(60)
READ(5,10)(YCA(J),J=1,28),(YCA(J),J=45,47),YCA(58),YCA(60)
READ(5,10)(ZCA(J),J=1,28),(ZCA(J),J=45,47),ZCA(58),ZCA(60)
10 FORMAT(BF10.0/BF10.0/BF10.0/BF10.0/BF10.0)
C  COORDINATES FOR FEET
DO 11 J=1,2
IRL=J+13
IHL=J+80
ITD=IHL+2
XCA(IHL)=XCA(IRL)-2.*COS(ANGFT(J))
YCA(IHL)=YCA(IRL)
ZCA(IHL)=ZCA(IRL)-2.*SIN(ANGFT(J))
XCA(ITD)=XCA(IRL)+8.*COS(ANGFT(J))
YCA(ITD)=YCA(IRL)
ZCA(ITD)=ZCA(IRL)+8.*SIN(ANGFT(J))

```

```

11 CONTINUE
R(27)=1.80
IF(NSEAT.NE.0)GO TO 12
C COMPUTE SEAT COORDINATES
XCA(31)=XBEAT
YCA(31)=.5*PW
ZCA(31)=ZBEAT
XCA(33)=XBEAT+PL*COS(THET)
YCA(33)=YCA(31)
ZCA(33)=ZBEAT+PL*SIN(THET)
XCA(35)=XBEAT-(SBH-ZBEAT)*SIN(THET)
YCA(35)=.5*SBH
ZCA(35)=ZBEAT+(SBH-ZBEAT)*COS(THET)
C COMPUTE CUSHION COORDINATES BASED ON THICKNESSES
XCA(52)=XCA(33)-THSCE*SIN(THET)
YCA(52)=YCA(33)
ZCA(52)=ZCA(33)+THSCE*COS(THET)
XCA(54)=XCA(35)+THBCE*COS(THET)
YCA(54)=YCA(35)
ZCA(54)=ZCA(35)+THBCE*SIN(THET)
XCA(50)=XCA(52)-(PL-THBCE)*COS(THET)
YCA(50)=YCA(31)
ZCA(50)=ZCA(52)-(PL-THBCE)*SIN(THET)
12 XCA(37)=0.
ZCA(37)=0.
XCA(39)=XFR
ZCA(39)=0.
XCA(41)=XFR+10.*COS(ANGFR)
ZCA(41)=10.*SIN(ANGFR)
SMIN=0.
SMIN=AMIN1(SMIN,XCA(35))
SMIN=AMIN1(SMIN,XSH)
YCA(37)=.5*(XCA(41)-SMIN)
YCA(39)=YCA(37)
YCA(41)=YCA(37)
DO 20 I=30,40,2
IF(NSEAT.NE.0.AND.I.LT.38)GO TO 20
XCA(I)=XCA(I+1)
YCA(I)=-YCA(I+1)
ZCA(I)=ZCA(I+1)
20 CONTINUE
C FOR RIGID SEAT MODEL ALL SEAT BACK NODES FALL IN ONE PLANE
IF(NSEAT.NE.0)GO TO 28
DO 810 I=30,31
XCA(I+25)=XCA(I)
YCA(I+25)=YCA(I)
ZCA(I+25)=ZCA(I)
810 CONTINUE
DO 23 I=49,53,2
XCA(I)=XCA(I+1)
YCA(I)=YCA(I+1)
ZCA(I)=ZCA(I+1)

```

```

23 CONTINUE
DO 820 I=49,50
XCA(I+8)=XCA(I)
YCA(I+8)=YCA(I)
ZCA(I+8)=ZCA(I)
820 CONTINUE
GO TO 27

C
C READ SEAT PAN AND BACK COORDINATES FOR FINITE ELEMENT MODEL
C
28 READ(5,100)(XCA(J),J=30,33),XCA(55),XCA(58),XCA(34),XCA(35)
READ(5,100)(YCA(J),J=30,33),YCA(55),YCA(58),YCA(34),YCA(35)
READ(5,100)(ZCA(J),J=30,33),ZCA(55),ZCA(58),ZCA(34),ZCA(35)
C CALCULATE SEAT PAN LENGTH FOR FINITE ELEMENT MODEL
PL=SQRT((XCA(30)-XCA(32))*2+(ZCA(30)-ZCA(32))*2)
C COMPUTE CUSHION COORDINATES FOR FE SEAT MODEL
XCA(51)=XCA(32)-THSCE*SIN(THPE)
YCA(51)=YCA(32)
ZCA(51)=ZCA(32)+THSCE*COS(THPE)
XCA(53)=XCA(34)+THBCE*COS(THBE)
YCA(53)=YCA(34)
ZCA(53)=ZCA(34)+THBCE*SIN(THBE)
XCA(52)=XCA(33)-THSCE*SIN(THPE)
YCA(52)=YCA(33)
ZCA(52)=ZCA(33)+THSCE*COS(THPE)
XCA(54)=XCA(35)+THBCE*COS(THBE)
YCA(54)=YCA(35)
ZCA(54)=ZCA(35)+THBCE*SIN(THBE)
C IF SEAT BACK AND SEAT PAN NODES ARE COINCIDENT
C THE PERFORM THE FOLLOWING CALCULATIONS
XCA(48)=XCA(51)-(PL-THBCE)*COS(THPE)
YCA(48)=YCA(30)
ZCA(48)=ZCA(51)-(PL-THBCE)*SIN(THPE)
XCA(50)=XCA(52)-(PL-THBCE)*COS(THPE)
YCA(50)=YCA(31)
ZCA(50)=ZCA(52)-(PL-THBCE)*SIN(THPE)
DO 830 I=49,50
XCA(I+8)=XCA(I)
YCA(I+8)=YCA(I)
ZCA(I+8)=ZCA(I)
830 CONTINUE
IF(XCA(30).EQ.XCA(55).AND.ZCA(30).EQ.ZCA(55))GO TO 850
DO 840 I=1,2
J=I-1
SLOPE2=(ZCA(55+J)-ZCA(30+J))/(XCA(55+J)-XCA(30+J))
THETA=ATAN(SLOPE2)
THETA1=-THETA
XCA(48+J)=XCA(51+J)-(PL-THSCE*SIN(THETA1))*COS(THPE)
YCA(48+J)=YCA(30+J)
ZCA(48+J)=ZCA(51+J)-(PL-THSCE*COS(THETA1))*SIN(THPE)

```

```

B2=ZCA(49+J)-SLOPE2*XCA(49+J)
THETA3=THEB-1.5708
SLOPE3=TAN(THETA3)
B3=ZCA(53+J)-SLOPE3*XCA(53+J)
XCA(57+J)=(B3-B2)/(SLOPE2-SLOPE3)
YCA(57+J)=YCA(53+J)
ZCA(57+J)=SLOPE2*XCA(57+J)+B2
840 CONTINUE
850 CONTINUE
27 XCA(42)=XLB(1)
YCA(42)=YLB(1)
ZCA(42)=ZLB(1)
XCA(43)=XLB(2)
YCA(43)=YLB(2)
ZCA(43)=ZLB(2)
IF(IRSYS.EQ.0) GO TO 21
XCA(44)=XBH
YCA(44)=YBH
ZCA(44)=ZBH
21 DO 25 I=1,84
P(I)=XCA(I)
Q(I)=YCA(I)
S(I)=ZCA(I)
25 CONTINUE
C TRANSFORMATION FOR Z AXIS ROTATION
ALPHA=.0174533*ALPHA
DO 30 I=1,84
XCA(I)=P(I)*COS(ALPHA)-Q(I)*SIN(ALPHA)
YCA(I)=P(I)*SIN(ALPHA)+Q(I)*COS(ALPHA)
30 CONTINUE
C TRANSFORM COCKPIT COORDINATES
IF(ICKPT.EB.0) GO TO 35
DO 32 I=1,10
P(I)=XCAS(I)
Q(I)=YCAS(I)
32 CONTINUE
DO 34 I=1,10
XCAS(I)=P(I)*COS(ALPHA)-Q(I)*SIN(ALPHA)
YCAS(I)=P(I)*SIN(ALPHA)+Q(I)*COS(ALPHA)
34 CONTINUE
C DETERMINE THE WORK BOX
35 XMAX=0.
XMIN=0.
YMAX=0.
YMIN=0.
ZMAX=0.
ZMIN=0.
DO 40 I=1,84
XMAX=AMAX1(XMAX,XCA(I))
XMIN=AMIN1(XMIN,XCA(I))
YMAX=AMAX1(YMAX,YCA(I))
YMIN=AMIN1(YMIN,YCA(I))
ZMAX=AMAX1(ZMAX,ZCA(I))
ZMIN=AMIN1(ZMIN,ZCA(I))
40 CONTINUE

```

```

IF(ICKPT.EB.0)GO TO 43
DO 42 I=1,6
XMAX=AMAX1(XMAX,XCAS(I))
XMIN=AMIN1(XMIN,XCAS(I))
YMAX=AMAX1(YMAX,YCAS(I))
YMIN=AMIN1(YMIN,YCAS(I))
ZMAX=AMAX1(ZMAX,ZCAS(I))
ZMIN=AMIN1(ZMIN,ZCAS(I))
42 CONTINUE
43 IF(NP.GT.1) GO TO 45
XSTEP=(XMAX-XMIN)/7.
ZSTEP=(ZMAX-ZMIN)/7.
STEP=AMAX1(XSTEP,ZSTEP)
45 XAXIS=XMAX-XMIN
YAXIS=YMAX-YMIN
ZAXIS=ZMAX-ZMIN
RXZ=XAXIS/ZAXIS
IF (RXZ.GE.1.) GO TO 50
ZAXIS=8.
XAXIS=ZAXIS*RXZ
GO TO 80
50 XAXIS=8.
ZAXIS=XAXIS/RXZ
80 CALL UNIDRAW(10)
ENCODE(18,70,NTIME) TIME
70 FORMAT(8TIME =,F7.4,5H SEC.,1H)
CALL BGNPL(NP)
CALL BLOWUP(XYFAC)
CALL TITLE (1H ,1,0,0,0,0,XAXIS,ZAXIS)
CALL HEADIN(30HPROGRAM SOM-LA OCCUPANT MODEL$,100,2,3)
CALL HEADIN (HEAD,80,2,3)
CALL HEADIN(NTIME,100,2,3)
CALL GRAPH (XMIN,STEP,ZMIN,STEP)
C DRAW BODY SEGMENTS
DO 80 I=1,17
IF(I.LE.11) IR=I
IF(I.GT.11) IR=IRINDX(I-11)
J=JINDX(I)
K=KINDX(I)
NPTS=NPINDX(I)
CALL CONTR(XCA(J),ZCA(J),XCA(K),ZCA(K),R(IR),NPTS)
CALL CURVE(X,Z,NPTS,0)
80 CONTINUE
C DRAW FACE
DO 82 I=1,7
J=JFNDX(I)
K=KFNDX(I)
CALL RLVEC(XCA(J),ZCA(J),XCA(K),ZCA(K),0)
82 CONTINUE
IF(ICKPT.EB.0.OR.ABS(ALPHA).GT.0.03) GO TO 88
C DRAW COCKPIT
DO 84 J=1,5
CALL RLVEC(XCAS(J),ZCAS(J),XCAS(J+1),ZCAS(J+1),0)
84 CONTINUE

```

```

C   DRAW SEAT AND FLOOR
88 DO 90 I=1,18
    J=JINDX(I)
    K=KKNDX(I)
    CALL RLVEC(XCA(J),ZCA(J),XCA(K),ZCA(K),0)
90 CONTINUE
    DO 91 I=1,17
    J=JLNDX(I)
    K=KLNDX(I)
    CALL RLVEC(XCA(J),ZCA(J),XCA(K),ZCA(K),0)
91 CONTINUE
C   DRAW RESTRAINT SYSTEM
C   LAP BELT
    IF(ALPHA.GT.0.785.AND.ALPHA.LT.2.358) GO TO 811
    IF(ALPHA.GT.3.927.AND.ALPHA.LT.5.488) GO TO 811
C   SIDE VIEW
    CALL RLVEC(XCA(80),ZCA(80),XCA(42),ZCA(42),0)
    CALL RLVEC(XCA(80),ZCA(80),XCA(43),ZCA(43),0)
    GO TO 82
C   FRONT OR REAR VIEW
911 CALL RLVEC(XCA(10),ZCA(10),XCA(42),ZCA(42),0)
    CALL RLVEC(XCA(11),ZCA(11),XCA(43),ZCA(43),0)
92 IF(IRSYS.EB.0) GO TO 84
C   SHOULDER HARNESS
    IF(IRSYS.NE.2) IBEG=45
    IF(IRSYS.EQ.2) IBEG=46
    IF(IRSYS.NE.1) IEND=46
    IF(IRSYS.EB.1) IEND=45
    DO 83 I=IBEG,IEND
    CALL RLVEC(XCA(I),ZCA(I),XCA(44),ZCA(44),0)
83 CONTINUE
    IF(ALPHA.GT.0.785.AND.ALPHA.LT.2.358) GO TO 831
    IF(ALPHA.GT.3.927.AND.ALPHA.LT.5.488) GO TO 831
    CALL RLVEC(XCA(58),ZCA(58),XCA(80),ZCA(80),0)
831 IEND=3
    IF(IRSYS.LT.4) GO TO 84
C   TIEDOWN STRAP
    XR(4)=XCA(48)
    ZR(4)=ZCA(48)
    CALL RLVEC(XCA(80),ZCA(80),XR(4),ZR(4),0)
    IEND=4
C   LABEL ANCHOR POINTS
94 IF(IRSYS.EB.0) IEND=2
    DO 96 I=1,IEND
    IF(I.EB.4) GO TO 96
    J=I+41
    XR(I)=XCA(J)
    ZR(I)=ZCA(J)
96 CONTINUE
    CALL MARKER(10)
    CALL CURVE(XR,ZR,IEND,-1)
    CALL RESET(8HMARKER)
    CALL ENDPL(NP)

```

```

IF (NP.GE.NCASE) GO TO 600
NP=NP+1
GO TO 500
600 CALL DONEPL
END
SUBROUTINE CONTR (XA,ZA,XB,ZB,A,NPTS)
COMMON X(100),Z(100)
DIMENSION R(50)
NHF=NPTS/2
NHFP=NHF+1
HALF=FLOAT(NHF)-.8
C CHECK IF A CIRCLE IS NEEDED
RL=SQRT((XA-XB)**2+(ZA-ZB)**2)
XD=(XA+XB)/2.
ZD=(ZA+ZB)/2.
AA=A*2.
IF (RL.GT.AA) GO TO 10
C DRAW THE CIRCLE
XX=-A
DO 20 I=1,NHF
R(I)=-((SQRT(1-(XX**2/AA**2))) * A
Z(I)=R(I)+ZD
X(I)=XX+XD
XX=XX+AA/HALF
20 CONTINUE
DO 30 I=NHFP,NPTS
K=NPTS+1-I
X(I)=X(K)
Z(I)=-R(K)+ZD
30 CONTINUE
GO TO 200
C DRAW THE ELLIPSE
10 B=RL/2.
CS=(XB-XA)/RL
SN=(ZB-ZA)/RL
XX=-B
DO 40 I=1,NHF
Z(I)=(SQRT(1-(XX**2/B**2))) * A
X(I)=XX
XX=XX+RL/HALF
40 CONTINUE
XX=B
DO 50 I=NHFP,NPTS
Z(I)=-((SQRT(1-(XX**2/B**2))) * A
X(I)=XX
XX=XX-RL/HALF
50 CONTINUE
DO 60 I=1,NPTS
XX=X(I)
X(I)=((X(I)+CS)-(Z(I)*SN))+XD
Z(I)=((XX*SN)+(Z(I)+CS))+ZD
60 CONTINUE
200 RETURN
END

```

APPENDIX F

SEAT PLOTTING PROGRAM

```

PROGRAM SEATPL(INPUT,OUTPUT,TAPES,TAPEB=OUTPUT,TAPE10)
DIMENSION XD(150),YD(150),ZD(150),X(150),Y(150),Z(150),THETA(20),
1PHII(20),TITLE(6),JB(150),JB1(150),JB2(150),JT(150),JT1(150),
2JT2(150),JT3(150),JS(50),JS1(50),JS2(50),JN(150),LABEL(4)
C READ HEADING AND NUMBER OF PLOTS, NODES, BEAMS, PLATES, SPRINGS
  READ(5,10)(TITLE(J),J=1,6)
 10 FORMAT(6A10)
  READ(5,15)NCASE,NNODE,NBEAM,NTPLT,NSPRG
 15 FORMAT(5I10)
C READ ELEMENT DATA (BEAMS, PLATES, SPRINGS)
  IF(NBEAM.EQ.0) GO TO 21
  DO 20 J=1,NBEAM
  READ(5,15) JB(J),JB1(J),JB2(J)
 20 CONTINUE
 21 IF(NTPLT.EQ.0) GO TO 26
  DO 25 J=1,NTPLT
  READ(5,15) JT(J),JT1(J),JT2(J),JT3(J)
 25 CONTINUE
 26 IF(NSPRG.EQ.0) GO TO 31
  DO 30 J=1,NSPRG
  READ(5,15) JS(J),JS1(J),JS2(J)
 30 CONTINUE
C START LOOP
 31 DO 4000 J=1,NCASE
  AMX=0.
  AMY=0.
  AMZ=0.
  ANX=0.
  ANY=0.
  ANZ=0.
C READ TIME AND VIEWING ANGLES
  READ(5,40)NOPLOT,TIME,THETA(J),PHII(J)
 40 FORMAT(I10,3F10.0)
C READ NODAL COORDINATES
  DO 50 I=1,NNODE
  READ(5,80)JN(I),XD(I),YD(I),ZD(I)
  AMX=AMAX1(AMX,XD(I))
  AMY=AMAX1(AMY,YD(I))
  AMZ=AMAX1(AMZ,ZD(I))
  ANX=AMIN1(ANX,XD(I))
  ANY=AMIN1(ANY,YD(I))
  ANZ=AMIN1(ANZ,ZD(I))
  M=JN(I)
  X(M)=XD(I)
  Y(M)=YD(I)
  Z(M)=ZD(I)
 50 CONTINUE
 80 FORMAT(I10,3F10.0)
  CALL UNIDRAW(10)
  CALL BGMPL(J)
  RAD=AMX-ANX+AMY-ANY+AMZ-ANZ

```

```

AX=(AMX-ANX)/2.
AY=(AMY-ANY)/2.
AZ=(AMZ-ANZ)/2.
ENCODE(33,100,LABEL)NOPLOT,TIME
100 FORMAT(9H PLOT NO.,I3,9H, TIME =,F7.4,5H SEC.,I10)
CALL TITL3D (1H ,1,8.,8.)
CALL HEADIN(3BHPROGRAM 80M-LA SEAT STRUCTURE MODEL$,100,2,3)
CALL HEADIN(TITLE,80,2,3)
CALL HEADIN(LABEL,100,2,3)
CALL AXES3D (0,0,0,0,0,0,0,0,0,0)
THE=THETA(J)
PHI=PHI(J)
CALL VUANGL (THE,PHI,RAD)
CALL GRAF3D (ANX,5HSCALE,ANY,5HSCALE,ANY,ANZ,5HSCALE,ANZ)
CALL MARKER (1)
CALL CURV3D (XD,YD,ZD,NMODE,-1)
CALL RLVEC3 (ANX,ANY,ANZ,AX,ANY,ANZ,2201)
CALL RLVEC3 (ANX,ANY,ANZ,ANX,AY,ANZ,2201)
CALL RLVEC3 (ANX,ANY,ANZ,ANX,ANY,AZ,2201)
CALL RLMES8 (2HX$, 100,X3DREL(AX,ANY,ANZ)+.15,Y3DREL(AX,ANY,ANZ)+.
115)
CALL PLMES8 (2HY$, 100,X3DREL(ANX,AY,ANZ)+.15,Y3DREL(ANX,AY,ANZ)+.
115)
CALL RLMES8 (2HZ$, 100,X3DREL(ANX,ANY,AZ)+.15,Y3DREL(ANX,ANY,AZ)+.
115)
CALL HEIGHT(.10)
DO 2000 I=1,NMODE
INUMBER =JN(I)
XX=XD(I)
YY=YD(I)
ZZ=ZD(I)
CALL RLINT (INUMBER,X3DREL(XX,YY,ZZ),Y3DREL(XX,YY,ZZ)+.10)
2000 CONTINUE
IF (NBEAM.EQ.0) GO TO 3100
DO 2100 I=1,NBEAM
K=JB1(I)
L=JB2(I)
X1=X(K)
Y1=Y(K)
Z1=Z(K)
X2=X(L)
Y2=Y(L)
Z2=Z(L)
CALL RLVEC3 (X1,Y1,Z1,X2,Y2,Z2,0)
2100 CONTINUE
3100 IF (NTPLT.EQ.0) GO TO 3200
DO 2200 I=1,NTPLT
K=JT1(I)
L=JT2(I)
M=JT3(I)

```

```
X1=X(K)
Y1=Y(K)
Z1=Z(K)
X2=X(L)
Y2=Y(L)
Z2=Z(L)
X3=X(M)
Y3=Y(M)
Z3=Z(M)
CALL RLVEC3 (X1,Y1,Z1,X2,Y2,Z2,0)
CALL RLVEC3 (X2,Y2,Z2,X3,Y3,Z3,0)
CALL RLVEC3 (X3,Y3,Z3,X1,Y1,Z1,0)
2200 CONTINUE
3200 IF (NSPRG.E8.0) GO TO 3300
DO 2300 I=1,NSPRG
K=JB1(I)
L=JB2(I)
X1=X(K)
Y1=Y(K)
Z1=Z(K)
X2=X(L)
Y2=Y(L)
Z2=Z(L)
CALL RLVEC3 (X1,Y1,Z1,X2,Y2,Z2,0)
2300 CONTINUE
3300 CALL ENDPL(J)
4000 CONTINUE
CALL DONEPL
END
```