

AD-A127 611

INTEGRATION ANALYSIS: A PROPOSED INTEGRATION OF TEST
AND EVALUATION TECHN. (U) NAVAL POSTGRADUATE SCHOOL
MONTEREV CA D L CARLSON MAR 83

1/1

UNCLASSIFIED

F/G 5/5

NL

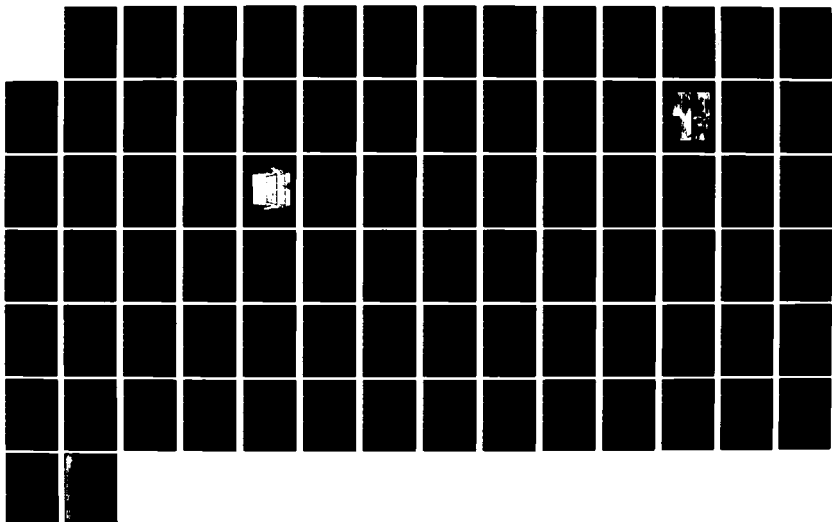

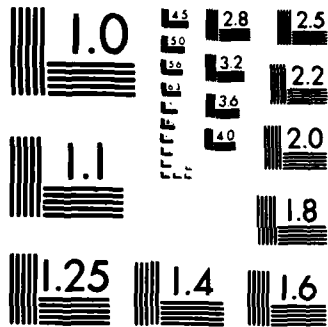

MICROCOPY RESOLUTION TEST CHART
NATIONAL BUREAU OF STANDARDS-1963-A

NAVAL POSTGRADUATE SCHOOL
Monterey, California



THESIS

INTEGRATION ANALYSIS: A PROPOSED INTEGRATION
OF TEST AND EVALUATION TECHNIQUES FOR EARLY
ON DETECTION OF HUMAN FACTORS
ENGINEERING DISCREPANCIES

by

David Lee Carlson

March 1983

Thesis Advisor:

Charles W. Hutchins

Approved for Public Release, Distribution Unlimited

AD 111 877 111

DMC FILE COPY

REPORT DOCUMENTATION PAGE		READ INSTRUCTIONS BEFORE COMPLETING FORM
1. REPORT NUMBER	2. GOVT ACCESSION NO.	3. RECIPIENT'S CATALOG NUMBER
4. TITLE (and Subtitle) Integration Analysis: A Proposed Integration of Test and Evaluation Techniques for Early on Detection of Human Factors Engineering Discrepancies		5. TYPE OF REPORT & PERIOD COVERED Master's Thesis March 1983
7. AUTHOR(s) David Leo Carlson		6. PERFORMING ORG. REPORT NUMBER
8. PERFORMING ORGANIZATION NAME AND ADDRESS Naval Postgraduate School Monterey, California 93940		9. CONTRACT OR GRANT NUMBER(s)
11. CONTROLLING OFFICE NAME AND ADDRESS Naval Postgraduate School Monterey, California 93940		10. PROGRAM ELEMENT, PROJECT, TASK AREA & WORK UNIT NUMBERS
14. MONITORING AGENCY NAME & ADDRESS (if different from Controlling Office)		12. REPORT DATE March 1983
		13. NUMBER OF PAGES 32
		14. SECURITY CLASS. (of this report)
		15. DECLASSIFICATION/DOWNGRADING SCHEDULE
16. DISTRIBUTION STATEMENT (of this Report) Approved for Public release; distribution unlimited		
17. DISTRIBUTION STATEMENT (of the abstract entered in Block 20, if different from Report)		
18. SUPPLEMENTARY NOTES		
19. KEY WORDS (Continue on reverse side if necessary and identify by block number) Task Analysis, Link Analysis, System Acquisition Cycle, Test and Evaluation, RAST, LSO Console Station, Operator Interviews, Functional Mockup.		
20. ABSTRACT (Continue on reverse side if necessary and identify by block number) The objective of this thesis is to address the idea of implementing a viable T&E technique at the early stages of DT&E in order to reduce design discrepancies and minimize acquisition costs and time. This technique involves integration of Task Analysis, Operator Interviews and Link Analysis to evaluate a system's Functional Mock-up. The technique will, therefore, be referred to as Integration Analysis throughout the paper. In order to provide a measure of its contribution, it will be implemented on a		

recently procured system that experienced numerous HFE design discrepancies at its OT&E stage. The system in question, the Recovery Assist, Securing, and Traversing (RAST) System associated with the LAMPS MK III Acquisition, revealed HFE problems in relation to its LSO Control Station. The use of the subject technique could have discovered a majority of those problems much earlier in the Acquisition Process.



Approved for Public Release, Distribution Unlimited

Integration Analysis: A Proposed Integration of Test and
Evaluation Techniques for Early on Detection of Human
Factors Engineering Discrepancies

by

David Leo Carlson
Lieutenant, United States Navy
B.S., United States Naval Academy, 1976

Submitted in partial fulfillment of the
requirements for the degree of

MASTER OF SCIENCE IN OPERATIONS RESEARCH

from the

NAVAL POSTGRADUATE SCHOOL
March 1983

Author:

David L. Carlson

Approved by:

Charles W. Hatcher Jr.
Thesis Advisor

Harold E. Hill
Second Reader

Charles T. Marshall
Chairman, Department of Operations Research

Charles T. Marshall
Dean of Information and Policy Sciences

ABSTRACT

The objective of this thesis is to address the idea of implementing a viable T&E technique at the early stages of DT&E in order to reduce design discrepancies and minimize acquisition costs and time. This technique involves integration of Task Analysis, Operator Interviews and Link Analysis to evaluate a system's Functional Mock-up. The technique will, therefore, be referred to as Integration Analysis throughout the paper. In order to provide a measure of its contribution, it will be implemented on a recently procured system that experienced numerous HFE design discrepancies at its OT&E stage. The system in question, the Recovery Assist, Securing, and Traversing (RAST) System associated with the LAMPS MK III Acquisition, revealed HFE problems in relation to its LSO Control Station. The use of the subject technique could have discovered a majority of those problems much earlier in the Acquisition Process.

TABLE OF CONTENTS

I. INTRODUCTION 8

II. GENERAL APPROACH 17

 A. FORMAL INTEGRATION 17

 B. GENERAL APPROACH 17

 C. PRACTICAL APPLICATION 21

 D. RAST SYSTEM DESCRIPTION 21

III. DEVELOPING A SUITABLE TASK ANALYSIS 26

 A. DEVELOPMENT 26

 B. PRACTICAL APPLICATION 29

 C. THE RECOVERY ASSIST TASK ANALYSIS 33

IV. LINK ANALYSIS 35

 A. FRAMES OF REFERENCE 35

 B. PRACTICAL APPLICATION 36

 C. APPLICATION OF RESULTS 42

V. OPERATOR INTERVIEWS 43

 A. QUESTIONNAIRE DEVELOPMENT 43

 B. QUESTIONNAIRE CONSTRUCTION 44

 C. RESULTS 45

VI. COMPARISONS AND CONCLUSIONS 48

APPENDIX A LSO CONTROL STATION DISCREPANCIES 51

APPENDIX B TASK ANALYSIS 53

APPENDIX C LINK ANALYSIS 61

APPENDIX D RAST SYSTEM'S LSO CONTROL STATION
QUESTIONNAIRE 69

LIST OF REFERENCES	80
INITIAL DISTRIBUTION LIST	82

LIST OF FIGURES

1.	Naval System Acquisition Test and Evaluation Cycle . .	11
2.	HFE & System Acquisition Cycle	14
3.	Photos of Flight Deck of USS McInerny (FFG-8)	23
4.	Flow Chart of Task Analysis Development	28
5.	LSO CONSOLE PANEL	30
6.	LSO Station Layout on the FFG-8	32
7.	Lines of Sight and Fields of View (FOV) From LSO Station and FFG-8 Flight Deck	37
8.	Lines of Sight and Fields of View (FOV) From FFG-8 LSO Station	39

I. INTRODUCTION

The overall effectiveness of a military system lies in the ability of the human to operate, maintain, and support the system's equipment. If the human element is not afforded the same amount of consideration as the hardware/software components of the system, the advances achieved in present day technology may never be totally realized. This understanding has created a greater concern for Human Factors Engineering (HFE) and its potential for improving the end product in system design.

A major catalyst for such concern has been shipboard air operations. Air operations include aircraft launch and recovery, flight control, and close aboard helicopter unique tasks such as vertical replenishment. The reasoning behind the requirement for HFE applications in air operations is that these operations generally include systems which:

1. Are highly complex and sophisticated and, therefore, difficult to operate and maintain
2. Require a high degree of interaction and coordination among operators
3. Require extensive human judgement and decision making
4. Comprise operations which are critical to the safety of aircrew and ship's personnel
5. Include sequences of operations which are highly time constrained and time critical. { Ref. 1 }

Such considerations have increased efforts to apply HFE technology during the Systems Acquisition Process. The development of a HFE Test and Evaluation Program has helped to structure these efforts and produce more efficient systems. MIL-H-46855B (Human Engineering Requirements for Military Systems, Equipment and Facilities) requires that a T&E Program be integrated into engineering design tests, contractor demonstrations, and Research and Development acceptance tests. Generally, the purposes of such a program are:

1. To assure fulfillment of applicable requirements
2. To demonstrate conformance of system, equipment and facility design to human engineering design criteria
3. To confirm compliance with performance requirements where man is a major system performance determinant
4. To secure quantitative measures of system performance which are a function of man-machine interactions
5. To determine whether undesirable design or procedural features have been introduced. {Ref. 2}

The implementation of the HFE Test and Evaluation concept into the Naval System Acquisition Cycle has, therefore, afforded the opportunity to validate system design throughout the entire Cycle.

The separation of the Cycle into a number of stages, including conceptual, validation, full scale development, and production/deployment lends itself to a series of check points during the system's acquisition process. At the

conclusion of each stage, the Defense System Acquisition Review Council (DSARC) assesses the achievement of the appropriate milestones. Each successive Review demands more stringent standards in relation to HFE design, thus, increasing the requirements for Test and Evaluation. { Ref. 4 }

In order to adequately cover the different stages of the Acquisition Cycle, T&E has been separated into two types, Development Test and Evaluation (DT&E) and Operational Test and Evaluation (OT&E). The process over the stages of the Acquisition Cycle is depicted in Figure 1. DT&E emphasizes the technological and engineering aspects of the system and is normally carried out under controlled conditions. OT&E includes all efforts in relation to obtaining operational information from prototype development through the system's life cycle. As a result, the T&E process follows the system from the completion of DSARC I and continues throughout its life. { Ref. 3 }

During DT&E the developing agency is responsible for conducting tests to verify system performance and solve technical problems. Basically, it must establish that the system meets performance requirements and objectives. It must, also, be operable, reliable, supportable, maintainable and have acceptable engineering. { Ref. 2 }

Prior to DSARC II, DT&E is concerned with identifying critical questions, issues, and possible deficiencies. After DSARC II it concentrates on identifying deficiencies and addressing any questions in order to achieve a system which is

NAVAL AIRCRAFT AND MISSILE ACQUISITION T&E CYCLE

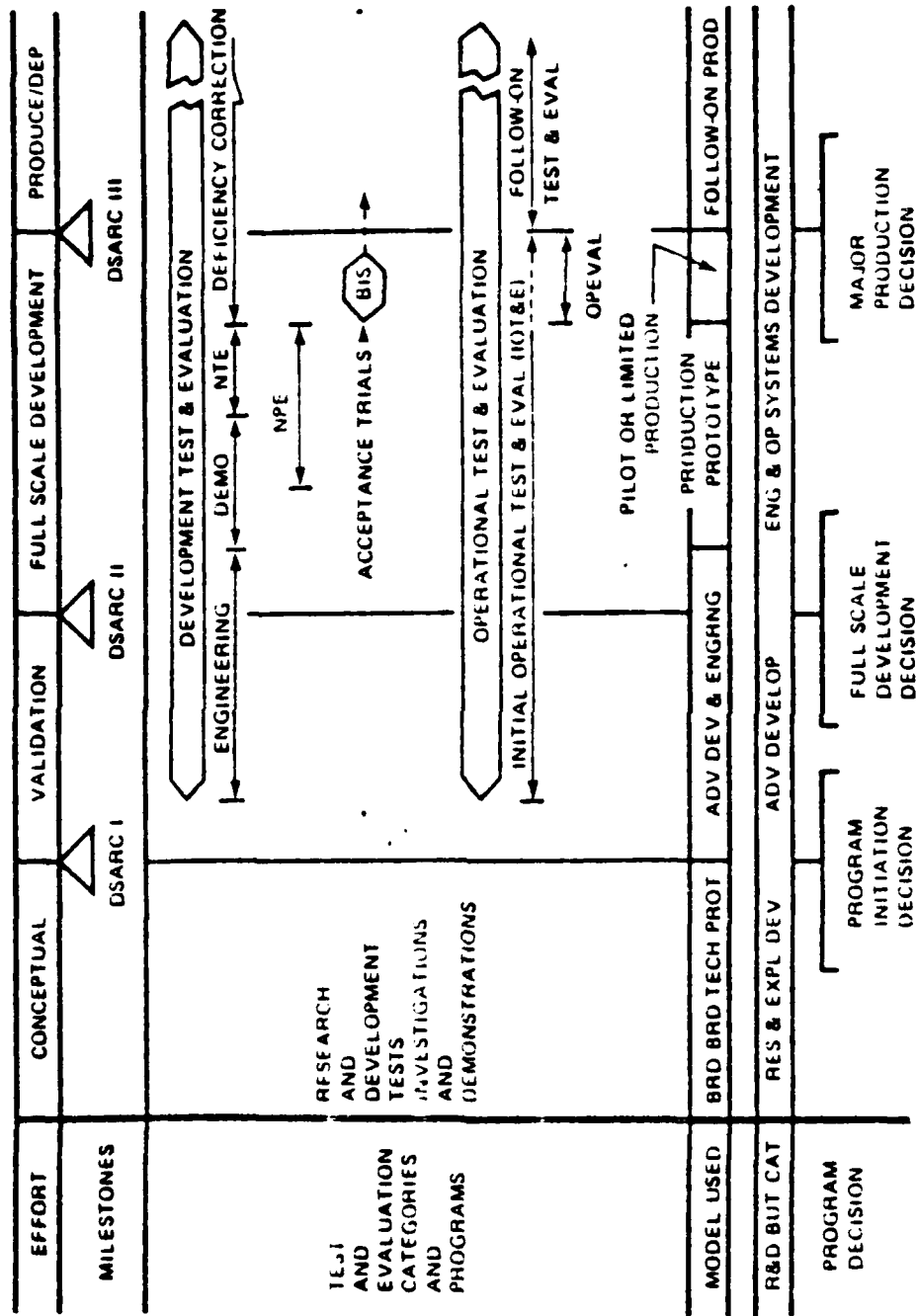

(FROM OPNAV INSTRUCTION 3960.8)

Figure 1. Naval System Acquisition Test and Evaluation Cycle
(Adapted from Ref. 2: p.5)

ready for production. After DSARC III, DT&E is relegated to validating the fact that deficiencies identified in OT&E have been corrected.

OT&E is divided into two types: Initial and Follow-on. Initial OT&E is accomplished prior to production (DSARC III). It uses information from DT&E testing and conducts its tests using prototypes or pilot production systems to determine operational effectiveness and suitability. Follow-on OT&E is conducted after the production decision and by fleet operational personnel.

In addition to the usage of controlled conditions for DT&E versus operational conditions for OT&E, there are other dimensions that make them different. Both DT&E and OT&E attempt to identify HFE discrepancies during their respective processes, however DT&E is initiated earlier in the Cycle and, therefore, may affect the number of deficiencies detected in OT&E.

Each system has various representations that are evaluated as the acquisition process proceeds, such as:

1. An analytic concept
2. Design drawings
3. Non-functional mockups
4. Functional mockups
5. Production Prototypes
6. Pilot Production items
7. Full Production items

While DT&E is applicable to any representation of a system, OT&E applies to only the last three. (Ref. 2)

Another difference is in terms of the operators. DT&E data are usually obtained by the evaluators or by test subjects selected to represent the actual users. OT&E uses personnel that will be eventual operators in the fleet.

Earlier initialization and a greater variety of system representation suggest that DT&E lends itself to a broader scope of T&E techniques during the Acquisition Process. Each additional system representation offers an additional opportunity to evaluate various aspects of the system by utilization of various techniques. The number of different techniques utilized is directly related to the expediency at which DT&E is organized and implemented into the Cycle. Once into the Cycle, the wide range of T&E approaches used in DT&E provides an opportunity to discover discrepancies early on, and therefore, enables a smoother OT&E process once it enters into the Cycle.

The application of a particular T&E technique in DT&E depends on the phase of the Acquisition Process involved. Each Phase requires the completion of certain milestones, or objectives, before the next Phase can be started, as depicted in Figure 2. The formal introduction of DT&E occurs after DSARC I. { Ref. 4 }

As the process continues, the system matures as do the T&E and DSARC requirements. It is important to realize that even though a system completes a milestone, the elements involved in that achievement are not considered finalized.

- I. Approval of MENS
- A. Requirements Phase
 - Is a new system needed?
 - What does it need to do?
 - Identifies Operational Conditions
 - Identifies Environmental Conditions
 - Analyzes Similar Systems
 - Milestone 0
- B. Conceptual Phase
 - Selection of alternatives
 - Can the requirements be met?
 - Requirements Analysis
 - Function Allocation
 - Manning Analysis
 - Position Descriptions
 - Task Analysis/Simulations
 - DSARC I- Milestone I
- C. Validation (Demonstration) Phase
 - Workspace Layout in response to communication, control, display and man-computer/machine requirements
 - Maintenance- Roles & Responsibilities
 - Job Performance Aids
 - Training- Skill/knowledge Requirements
 - Media
 - Personnel
 - DSARC II- Milestone II
- D. Full Scale Development Phase
 - Contractual Requirements
 - Mockups
 - System Simulations
 - Prototype Eval: DT&E/OT&E
 - Critical Design Reviews
 - Pilot Test of Training Program
 - Maintenance Procedures
 - Operational Procedures
 - DSARC III- Milestone III
- E. Production/Deployment Phase
 - Modifications
 - Safety

Figure 2. HFE & System Acquisition Cycle

As the System develops, operational procedures, new technology, or newly discovered design discrepancies may force engineering changes or re-evaluation of the analyses conducted in the Conceptual Phase. This causes a hold up in the Process until the system is re-evaluated using the modified version. Such a looping effect results in time delays and cost overruns. Granted, new technology and changes in tactical doctrine should be implemented if feasible, but redesigns, especially well into the Cycle, can and should be minimized. Therefore, the early introduction of T&E into the Cycle is imperative.

The completion of the system's Task Analysis provides an opportunity for initiation of techniques to identify HFE design deficiencies. The Task Analysis is quite adaptable to the various testing approaches available to DT&E. In combination with system Mock-ups or models, adequate operational scenerios can be developed and evaluated with respect to HFE design. Such evaluations can be repeated inexpensively throughout the acquisition cycle to analyze changes in operational procedures or new technology. Most importantly, the early appearance of DT&E in the Acquisition Cycle provides an advanced opportunity to discover design discrepancies on a maturing yet viable system.

The objective of this thesis is to address the idea of implementing a viable T&E technique at the early stages of DT&E in order to reduce design discrepancies and minimize acquisition costs and time. This technique involves integration

of Task Analysis, Operator Interviews and Link Analysis to evaluate a system's Functional Mock-up. The technique will, therefore, be referred to as Integration Analysis throughout the paper. In order to provide a measure of its contribution, it will be implemented on a recently procured system that experienced numerous HFE design discrepancies at its OT&E stage. The system in question, the Recovery Assist, Securing, and Traversing (RAST) System associated with the LAMPS MK III Acquisition, revealed HFE problems in relation to its LSO Control Station. The use of the subject technique could have discovered a majority of those problems much earlier in the Acquisition Process.

II. GENERAL APPROACH

A. FORMAL INTEGRATION

The formal integration of DT&E into the System Acquisition Process implies an advanced version of the Task Analysis for the subject system. In order to set HFE T&E off to an expeditious and comprehensive start, the availability of the Task Analysis offers an immediate evaluation technique.

The detailed steps of the Task Analysis makes it possible to conduct a Link Analysis of the system's various operational scenerios. The information obtained from the Link Analysis may point out HFE design problems encountered during the course of the system's task sequence. The Task Analysis can also be used to create the system's operation on a Functional Mock-up. Any problems experienced by the Mock-up's operators during the performance of their tasks may reveal HFE discrepancies. When the results of the Link Analysis and the Operator Interviews are combined for comparison and verification, the HFE T&E process will have been given an early, relatively inexpensive, and substantial boost.

B. GENERAL APPROACH

The general approach to this evaluation procedure includes the following steps;

1. Participation in the development of the Task Analysis to ensure adequate details are included for use in T&E.

2. Incorporate the Task Analysis into the development and operation of a Functional Mock-up.
3. Perform a Link Analysis by following each operational scenario in the Task Analysis.
4. Evaluate the Link Analysis results with respect to suboptimal HFE.
5. Interview the operators of the Mock-up with a well structured procedure for extracting both obvious and underlying HFE problems.
6. Compare the Link Analysis with the Interviews to correlate discovered discrepancies.

A Task Analysis is a study that develops a sequence of tasks necessary to accomplish each function allocated to man {Ref. 5}. It determines information and control requirements, skill and knowledge requirements, possible errors associated with each task and their implications, workloads, and scheduling (simultaneous or individual task execution) {Ref. 6}. The evaluator's involvement in the completion of the Task Analysis ensures that these necessary details are included, and sufficiently covered. A simple sequential listing of the tasks doesn't provide the necessary information to ascertain if a particular task can be performed adequately, if at all.

With a comprehensive Task Analysis in hand, the operation of the system on a Functional Mock-up can be conducted in controlled, but adequately realistic conditions. The controlled environment actually affords the operators a greater opportunity

to fully judge if each task can be completed according to the information and control requirements stipulated by the Task Analysis.

Link Analysis is a technique which provides information needed to produce an acceptable arrangement of men and machines in a system {Ref. 6} . Before a link analysis can be performed, firm decisions must be made about the exact items of equipment to be used, the number of men who will operate them, and the functions that will be performed {Ref. 5}. The rationale behind the link analysis techniques is that the "best arrangement" can be found only by optimizing different types of links that are important in the particular system being designed. A link is a connection between (a) an operator and a machine or (b) two operators. The links may be visual (such as an instrument scan), functional (hand to control), or verbal. Inefficiencies occur when links are comparatively long, crossing one another, blocked, or outside optimal visual or reach envelopes. The links produced from the Task Analysis illustrate all the operator required functional, visual, and communication tasks. The Link Analysis can be applied to all scenerios involved during all operational and emergency conditions. {Ref. 5 and 6}.

Since the Link Analysis depicts every requirement and the possible restrictions in their attainment, the Link Analysis may reveal problems that could be unconsciously compensated for by the operator during the Mock-up operation. By conducting

the Link Analysis evaluation before the Operator Interviews, these compensation areas could be addressed in the interview in order to access their degree of importance.

The Operator Interviews are sectioned into two types of questions: general and specific. The interview begins with general questions to determine whether any performance problems have been noted by the operator. More specific questions follow to cover the range of equipment/job variables that could influence performance such as:

1. Equipment characteristics
2. environment
3. job aids
4. safety
5. manning
6. training
7. information
8. communications

It is assumed that if the System test consists of several operations or cycles, the operator will be interviewed following each such operation cycle. (Ref. 7)

The final step in this integrated HFE evaluation technique involves the compilation of all the information obtained through the link analysis and the interviews. This comparison step can help verify discrepancies and provide a means for selecting correction priorities for each discrepancy. Further, it may be possible to discover other problems when the two techniques

are combined and analyzed. What appears to be satisfactory evaluations for the individual techniques, may reveal underlying problems when all the information is integrated.

C. PRACTICAL APPLICATION

A practical application of this formal integration of Task Analysis, Link Analysis, and Operator Interviews on a Functional Mock-up was implemented on the RAST System. It concentrated on the System's primary operating area, the Landing Safety Officer (LSO) Control Station. Even though the System is near its completion in the Acquisition Process, the comparison of this technique's contribution to HFE T&E when applied during the System's early development and the actual multiple HFE discrepancies discovered during the System's advanced stages give a direct measure of its worth in relation to redesign costs and Acquisition Process time delays.

D. RAST SYSTEM DESCRIPTION

The RAST System was developed in an attempt to increase safety during helicopter launch, recovery, and deck traversing on single landing area air-capable ships such as Frigates and Destroyers. It is being implemented on the Oliver H. Perry Class Frigates (FFG-7) and the Spruance Class Destroyers (DD 963). In conjunction with the LAMPS MK III development, one system was installed on the USS McInery (FFG-8) for System Acquisition evaluation. { Ref. 8 }

The RAST System is designed to support the landing, launching, and handling of helicopters during sea conditions

of up to sea state five. The System has four major operational segments:

1. Traversing the Helo across the flight deck (in or out of hanger)
2. Launch
3. Recovery
4. Maneuvering and Straightening the Helo for alignment with the track

Control of the RAST System is accomplished by the LSO located at a control console within a rigidly constructed enclosure that protrudes above the flight deck as depicted in figure 3. The LSO's responsibility for visual inspections of the helicopter during operations necessitates the station's close proximity to the landing-launch area. (Ref. 8)

A typical operating cycle of the RAST system includes: traversing the helicopter along a track from the hanger aft to the launch area; helicopter launch; hook-up of the helicopter with the hauldown cable; hauldown and securing of the helicopter; alignment of the helicopter with the track; and traversing the helo forward into the hanger. The LSO must be fitted with the controls, displays, and communications equipment necessary for the safe and efficient conduct of the operation's cycle.

In detail, the Recovery Assist Mission is as follows; As the helicopter approaches, a messenger cable is deployed from the helicopter to the flight deck below. The RAST

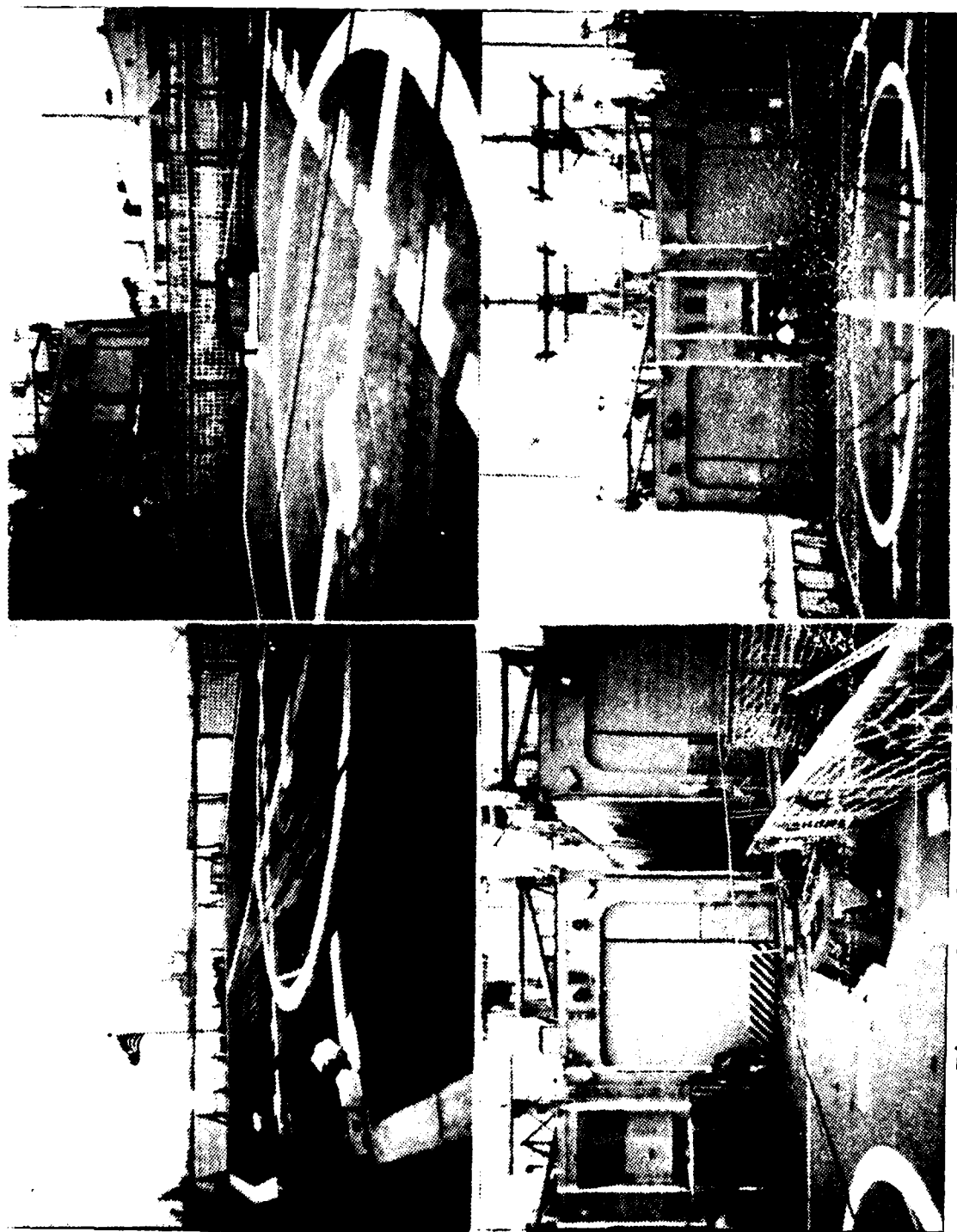

Figure 3. Photos of Flight Deck of USS McINERNEY (FFG-8)

cable is attached to the messenger cable and winched up by the aircraft. After the cable end fitting is locked into the aircraft's main probe, the pilot selects the appropriate power setting to maintain hover over the ship's flight deck. The cable, tensioned with 4,000 pounds pull, is controlled by the LSO who operates the RAST console on deck. The LSO waits for a trough in the swells, signals the pilot, and through their quick and coordinated action, the tensioned cable assists the helicopter to land safely. The main probe engages an arresting device, called the Rapid Securing Device (RSD), which secures the helicopter probe to the deck. The pilot then shuts the aircraft down. (Ref. 9)

The basic plan for the system presently installed on the USS McInery used the Canadian Beartrap configuration as an initial guideline. The placement and configuration for each RAST subsystem was determined with the help of land based mock-ups of the ship's flight deck and RAST control rooms. The prototype was then installed on the McInery for at-sea evaluations in conjunction with the LAMPS MK III program. During the LAMPS MK III TECHEVAL in 1981, the LSO's Control Station revealed a substantial amount of HFE deficiencies (Ref. 8 and 10). Some of the general problems encountered include:

1. Restricted fields of vision.
2. Controls, displays, and communication equipment not optimally placed.
3. Inadequate exterior and interior lighting.
4. Complex control manipulation.

After the at-sea TECHEVAL (Ref. 8), a review of the LSO Station was conducted at a mock-up with the Naval Architects of Gibbs and Cox, Inc. (Ref. 10). The participants of the TECHEVAL recommended design changes and modifications to the station in order to correct identified design deficiencies or enhance its operational suitability and human factors characteristics.

The changes resulting from the mock-up review (Ref. 10) and the discrepancies reported in the NATC Technical Report RW-30R-81 (Ref. 8) greatly improved the HFE of the station, but it still held up the Acquisition Process. A listing of the TECHEVAL and Mock-up review discrepancies and changes is contained in Appendix A.

The demonstrative application of the proposed Integration Analysis will focus solely on the LSO Station installed on the USS McInery and will be directly applicable only to FFG-7 class ships. The location of the station on other class ships, such as the DD 963's, will be different and therefore have unique perspectives and constraints requiring a separate, but procedurally equivalent analysis. It should be realized that an attractive characteristic of Integration Analysis is that its general methodology is an applicable evaluation technique for any complex man-machine system.

III. DEVELOPING A SUITABLE TASK ANALYSIS

A. DEVELOPMENT

The ability of Integration Analysis to detect HFE discrepancies has a great dependence on the comprehensiveness of the Task Analysis. An inadequate attention to detail may miss some of the information required by an operator, exclude short but important tasks, and/or fail to reveal the complexities of a specific task.

A useful Task Analysis for this type of HFE T&E technique must consider the information, control, and performance requirements for all operational and environmental conditions. It must, also, address performance error impacts, workloads, and scheduling effects for these conditions (Ref. 6) .

In order to produce an adequate Task Analysis, the steps that involve the gathering and organizing of the information needed to develop it must be completed and understood. These steps include:

1. Review Operational and Technical Documentation
2. Assess System/Mission Requirements
3. Identify applicable operational and environmental conditions
4. Functional Analysis
5. Requirements Analysis
6. Function Allocation
7. Work Station Design

These steps flow in a sequence (figure 4) that eventually accumulates and integrates all the information needed to develop a comprehensive flow of the sequential tasks of a system {Ref. 1 and 2}.

To begin, a study of the System's operation and maintenance manuals and interviews with system designers gives one an understanding of the capabilities and constraints of the system. By simply knowing the basic operation of the controls and displays, the analyst will better appreciate the complexities of the system.

Once the System/Mission requirements are known, all the operational and environmental conditions that could be encountered in meeting those requirements can be identified. The T&E process must be aware of all possible conditions, otherwise analysis of the system may not have an opportunity to evaluate the system's full spectrum of usage. Such incomplete analysis may delay discrepancy detections until the system is used in actual operations by the Fleet.

The Functional Analysis lists the functions to be carried out to complete each Mission requirement. The analysts initial research of the operation and maintenance manuals affords a full understanding of each function and its associated complexities.

The Requirements Analysis determines the information and performance requirements for each function under each operational and environmental condition {Ref. 5}. To be complete, it should include emergency procedures/conditions.

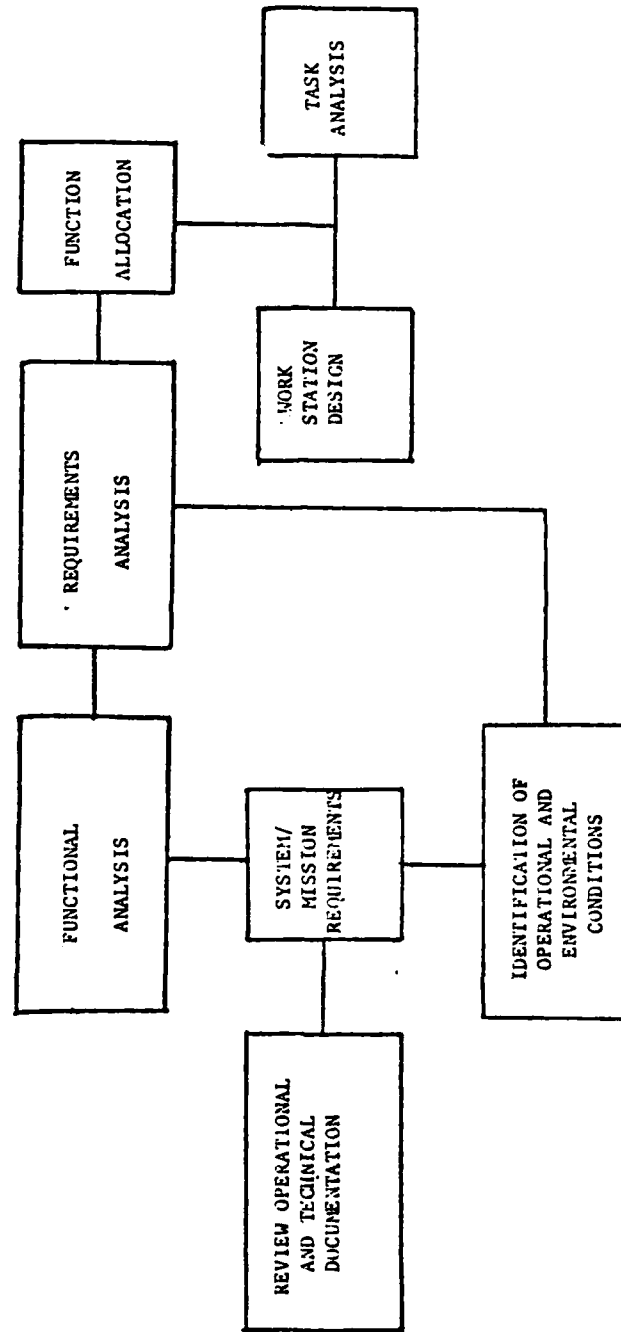

Figure 4. Flow Chart of Task Analysis Development

Once the integration of the functions and their associated information and procedure requirements is complete, the allocation of certain functions to either man or machine can be conducted. This in turn leads to a workspace design and an opportunity to evaluate that design using the Task Analysis.

B. PRACTICAL APPLICATION

Research into the LSO Console Station's development failed to produce a Task Analysis suitable for an application of Integration Analysis. The best report located was a Task Listing made for an LSO Training Program (Ref. 9). It covered all operational scenarios and their respective emergency procedures, but fell far short of adequately addressing environmental conditions, error impact, and information requirements for decision making.

By following the steps of the Task Analysis Development Sequence (Figure 4), a comprehensive Task Analysis was produced. The sequence was used as a checklist to be sure that all the necessary ingredients of an adequate Task Analysis were present.

Step 1; It was obviously necessary to fully understand the operation of the LSO Station before any analysis could be conducted. Control of the RAST System is primarily conducted at the LSO's control console (Figure 5). Through research of the Console's Operation and Maintenance Manual (AD-700A0-OMI-010) (Ref. 11), review of the ship's Helo Flight Operations Bill (Ref. 12), studying of the LSO Training Syllabus Ref. 13, and repetitive question sessions with project managers, most

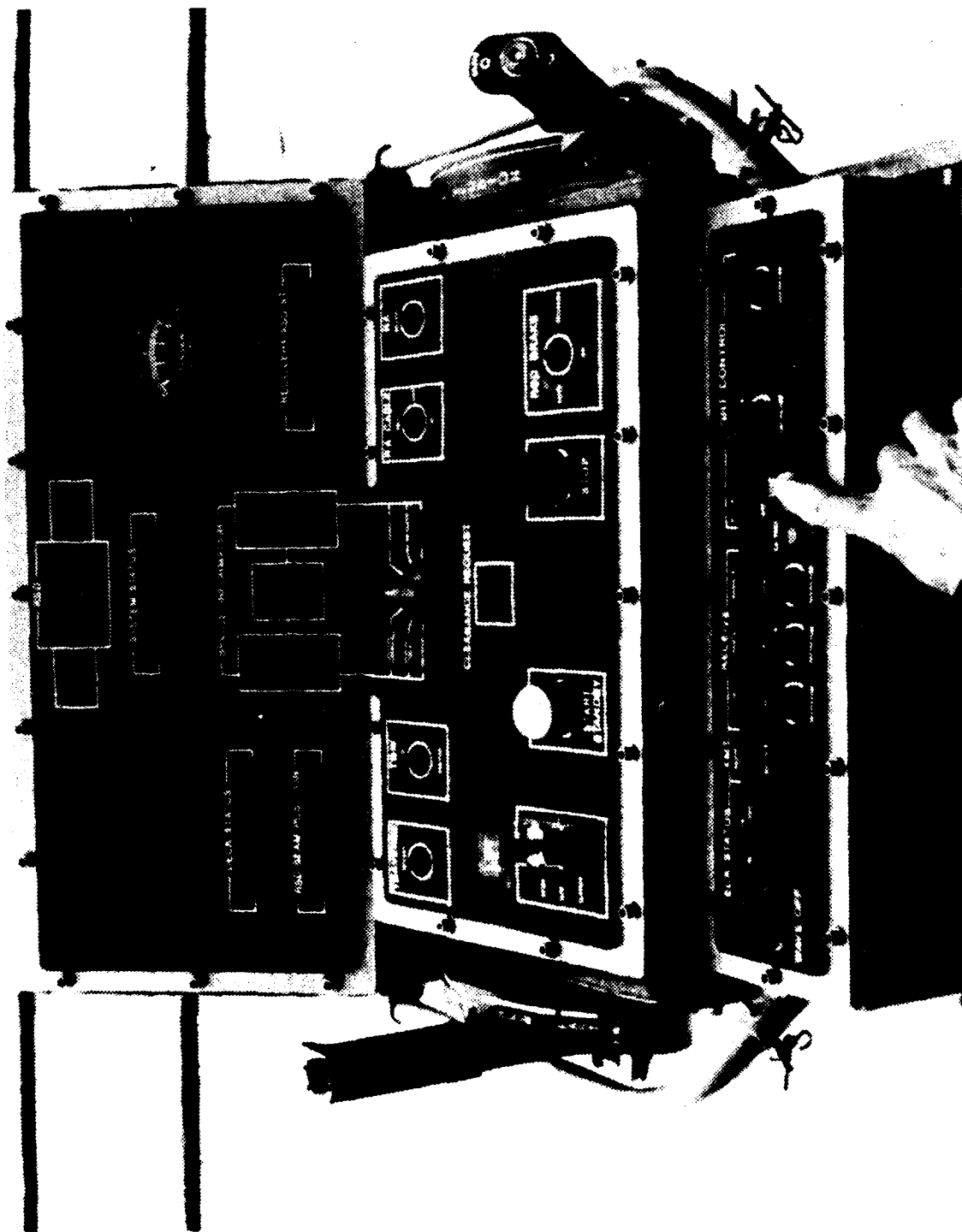

Figure 5. LSO CONSOLE PANEL

control and display idiosyncrasies were identified. Then the location of each control and display in the Station, but not on the console, was determined and their operation understood (Figure 6).

Steps 2 and 3; Recall that the RAST System has four major operational segments:

1. Traversing
2. Launch
3. Recovery Assist
4. Maneuvering and Straightening

The LAMPS MK III Mission is expected to be conducted in most weather conditions (Sea State 5 or below) {Ref. 8}. Therefore, the RAST needs to be evaluated for each of these conditions:

1. Day or Night
2. Tropical or Artic temperatures
3. Rain or Snow
4. Maximum ship Pitch and Roll
5. Shipboard Fire
6. Aircraft Crash

The results of the Functional Analysis were basically represented in both the Task Listing and the LSC Training Syllabus. Therefore, the necessary inputs to the Requirements Analysis, steps 3 and 4, were available.

With the review of the Task Analysis Development accomplished to this point, the information was organized and integrated into a Task Analysis suitable for Integration Analysis.

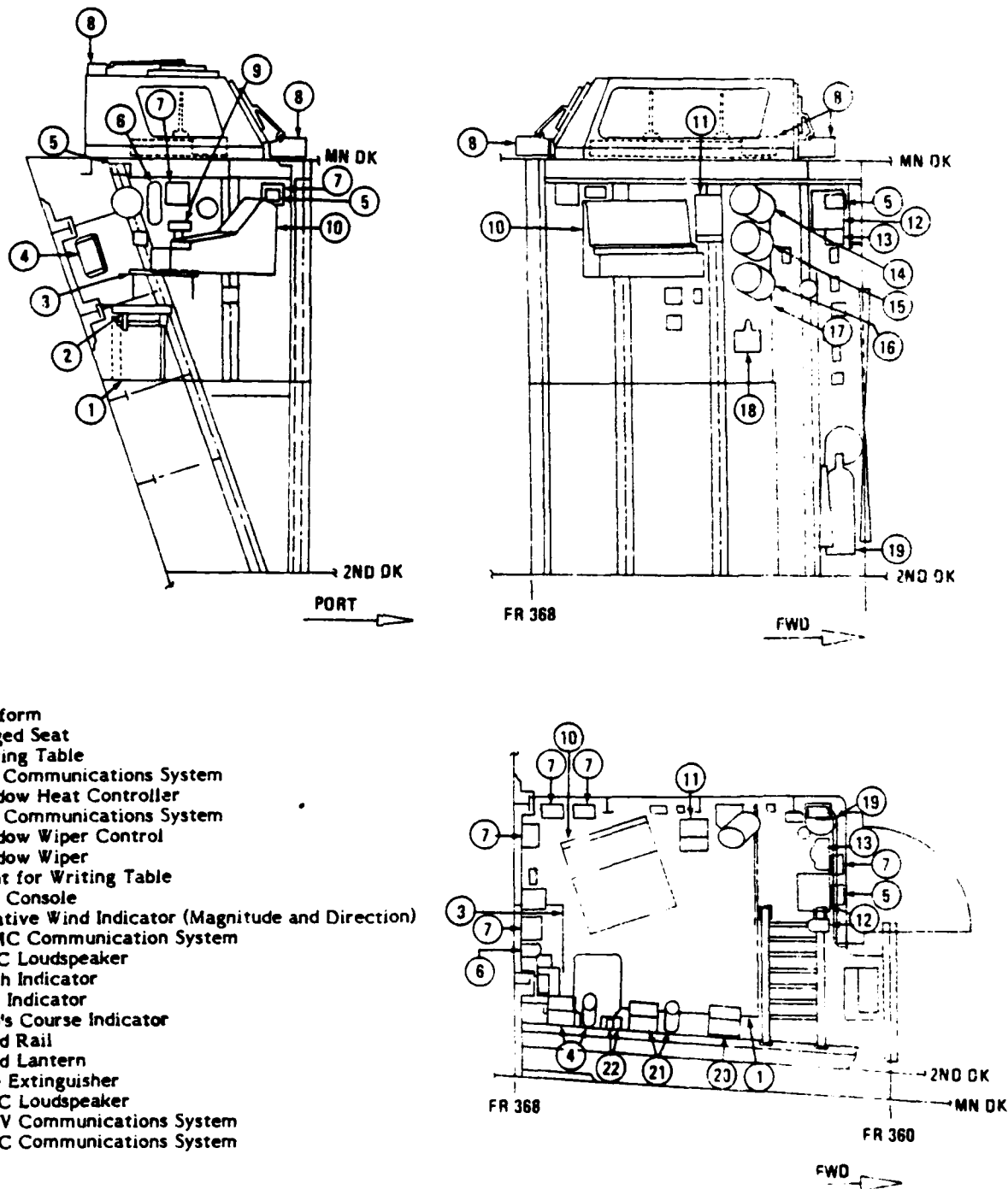

Figure 6
 LSO Station Layout on the FFG-8
 (Obtained from Redesign Agency,
 GIBBS&COX INC., NEW YORK, N.Y.)

C. THE RECOVERY ASSIST TASK ANALYSIS

In order to scale this practical example down, only the Recovery Assist segment of the RAST's operation will be explained in detail with respect to Integration Analysis. The Recovery operation entails the most safety related and complex tasks. The overall results of the analysis will be presented in the conclusions.

The Task Analysis for the Mission of Recovery Assist (Appendix B), was constructed using the LSO's Task Listing {Ref. 9} as a guideline. By enriching the contents of the Task Listing with the information accumulated from the research conducted on the System, the resulting Task Analysis addressed vital areas of concern for Integration Analysis and, in general, HFE T&E. It should be noted that the Task Listing was also produced using the development sequence discussed earlier in this chapter, however it didn't go into sufficient detail for our purposes.

Each task was separated into subtasks and each subtask was analyzed with respect to:

1. Performance Actions
2. Knowledge/Information required to carry out the subtask
3. The Control(s) involved in the subtask
4. The Display(s) involved in the subtask
5. Possible Constraints/Malfunctions that may hinder the conduction of the subtask
6. The impact of an error performed during the subtask

The actions performed during a subtask are basically the result of the functional analysis and function allocation. A working knowledge of the system is necessary to fully appreciate this section.

The Knowledge/Information required to carry out each subtask is obtained through the requirements analysis. It is imperative that this section be as complete as possible. The results of this section affords the basis of the Possible Constraints encountered section. If an Information requirement is missed, certain constraints may be overlooked and may possibly result in an unnoticed HFE discrepancy.

The Possible Constraints section deals in both specific and general terms. It is designed to draw attention to various areas of interest for each subtask. For example, Visual Obstruction can include restricted fields of vision due to structural design, glare, direct sun, rain, snow, fog, or perspective. Indicator Illumination describes inadequate illumination of a display due to glare, inadequate lighting, or electrical problems. Specifics attempt to draw attention to control operation, displays (or lack of them), and coordinated maneuvers that may overload the operator.

Error Impact is used to give the analyst an idea of the severity of a constraint or the lack of information necessary to complete a task.

IV. LINK ANALYSIS

A. FRAMES OF REFERENCE

Once a comprehensive Task Analysis has been developed, the next step in the general approach to Integration Analysis is the concurrent application of the Task Analysis to the operation of the system's Functional Mock-up and the performance of a Link Analysis. The design of the Functional Mock-up is a result of research that uses the task analysis to develop the crew station configuration. A practical application of the Task Analysis to the Mock-up is, therefore, evaluating that design and, for Integration Analysis purposes, preparing the subjects for the operator interviews. The Link Analysis is helping to create pertinent questions to be asked in those interviews.

The analyst's approach to the development of the Link Analysis depends on the system's general mode of operation. The information generated or used throughout the system's operation is acquired in either a) two dimensional or b) three dimensional frames of reference. Two dimensional examples include a Radar Console panel in the Combat Information Center (CIC) on a ship or an operations floor plan where various operating stations are positioned throughout a room to provide expeditious interactions, such as CIC. All the information associated with the Radar Console can be depicted

by one diagram of the panel and all the interactions of the operators can be illustrated by an overhead view of the room's floor plan. A three dimensional mode of operation involves the use of links from sources external to the system's control center. As with the RAST's Recovery Assist mission, information vital to the system's operation involves visual and communications links external to the station. The two dimensional depiction of the console panel is insufficient to adequately cover the operation's various information links. Various scales and frames of reference need to be used in such a cost to clearly display each link during the system's operation. Clarity and simplicity is vital if the benefits of link analysis are to be realized.

B. PRACTICAL APPLICATION

The Recovery Assist link analysis began with the identification of the external visual links of the operation. Figure 7 shows the location and lines of sight for each visual link involved in the complete mission.

By starting out with an expanded external view the analyst is given the "big picture" in relation to the system's operation. This view also shows that the operation entails visual links that require more than a single plane of reference. The Hover/Centering and the Approach links indicate that information acquisition is going to require extensive fields of view.

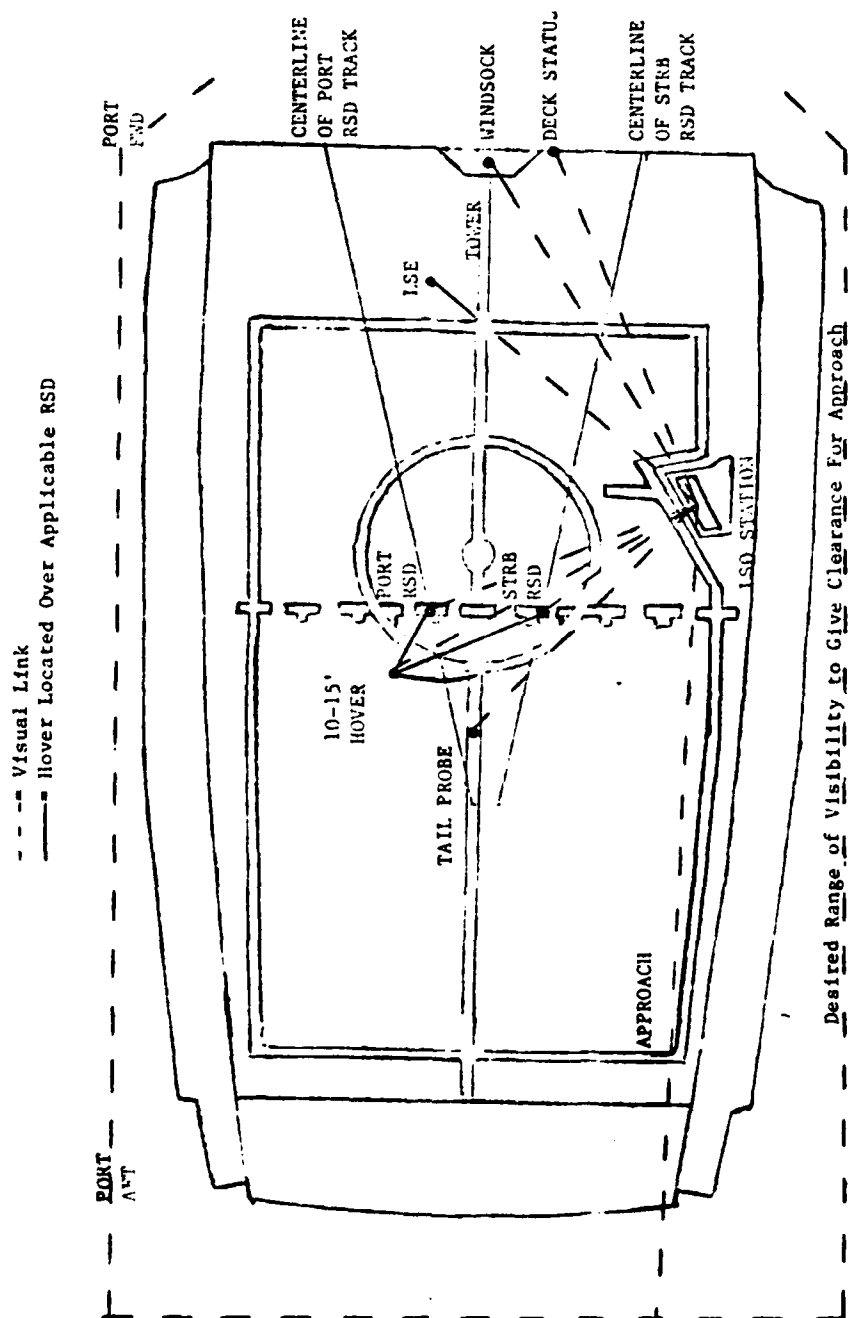

Figure 7. Lines of Sight and Fields of View (FOV) From LSD Station and FFG-8 Flight Deck

Inspection of this most general link diagram produces the following observations:

1. A narrow field of view exists with respect to a hovering helo over the RSD's. Lateral positioning of the helo could prove difficult due to the operator's acute perspective.
2. Starboard side clearance for approach will be impossible due to the lack of a rear window at the station.

By telescoping down to a more detailed representation of the LSO Station, the visual links can be better scrutinized. Figure 8 deals with the same visual links as in Figure 7, but the links are analyzed on a smaller scale. This results in the links indicating possible structural obstructions. The restrictions due to the lack of a rear window are illustrated more dramatically at this scale. Further, the severity assessment of the various window frame restrictions is excellent material for the operator interviews.

The next step in the scaling down process involves analysis of the system's central control panel, the LSO console panel. Since the external links have been addressed, the link analysis can be conducted on a two dimensional frame of reference as depicted by the Console diagrams in this chapter's appendix. This approach focuses the analyst's attention on the arrangement of the displays and controls used during the Recovery Assist mission. Relative directions of the lines of sight external to the station are sufficient for this scale of

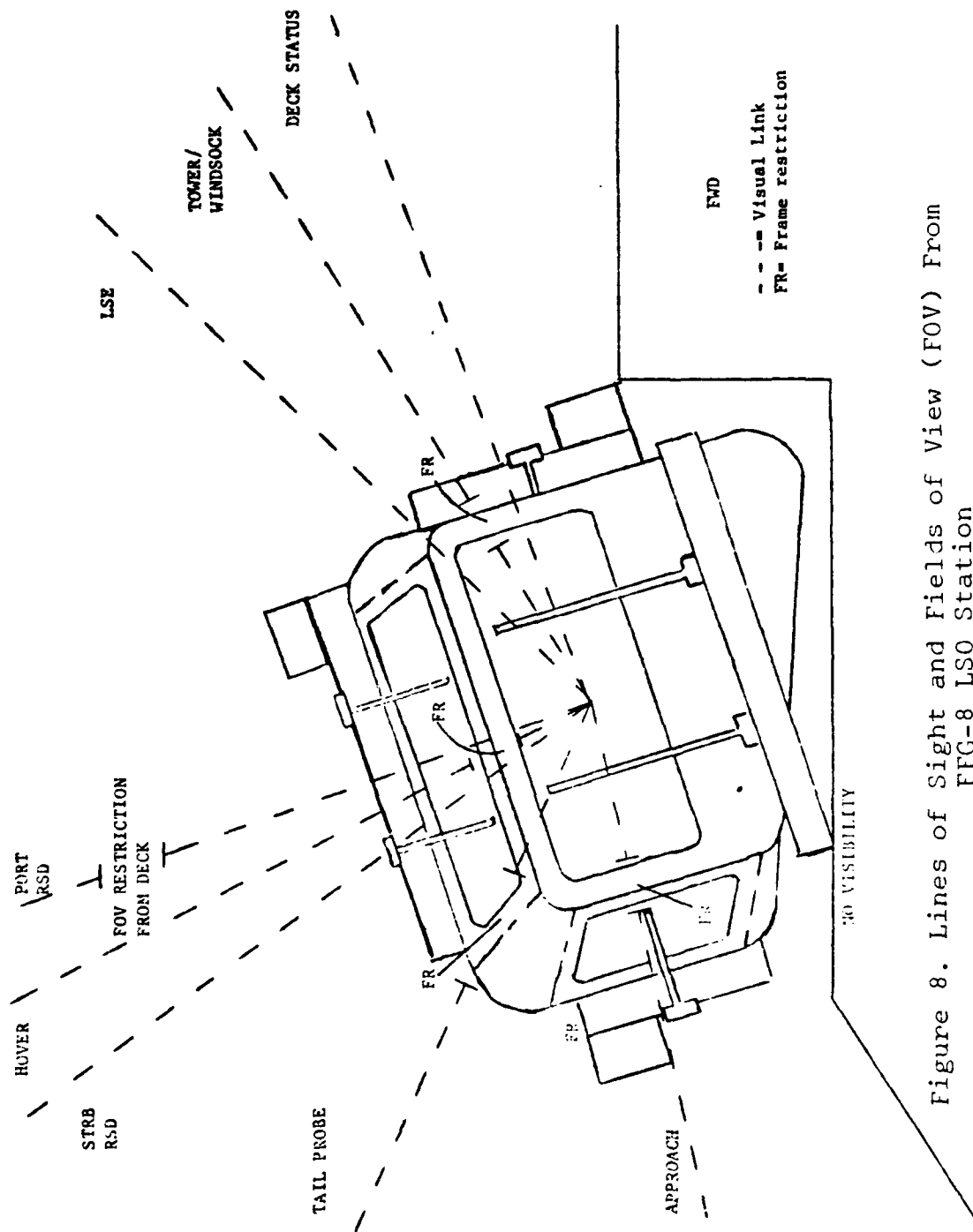

Figure 8. Lines of Sight and Fields of View (FOV) From FFG-8 LS0 Station

analysis, but internal visual links need to be illustrated as accurately as the manual links in order to judge optimal display-control arrangements.

The links are numbered to coincide with the tasks and subtasks of the Task Analysis (Appendix C). Each subtask contains their own combination of manual and visual interactions, thus they may result in strictly manual links, strictly visual links, or a sequential combination of manual and visual links. The internal visual links directed to the right of the console refer to lines of sight to the wind speed/direction, pitch, roll, and ship heading indicators (see Figure 6 for exact locations and arrangement).

The links are analyzed for the following discrepancies:

1. Links crossing within a task indicating inadequate arrangements.
2. Sequences of links that cause a large manual and/or visual envelope for a task. In this case, if the manual links for a particular hand and their associated visual links are not in a narrow envelope, the controls and displays for that task are not close enough or in line with each other.
3. Links that indicate excessive operator workloads. This may result during coordinated maneuvers that involve multiple subtasks at a certain control in a short period of time. Performance errors become common place in such a situation.

4. Long manual or internal visual links.
5. Links that go outside optimal visual or reach envelopes. Primary displays should have envelopes of 15 degrees from either side of the line of sight, 35 degrees for secondary. Control envelopes depend on workstation design, but are in many respects similar to display envelopes. { Ref. 5 }

The first major discrepancy occurs at task 3-4 where, once again, the visual clearance for approach is blocked by the lack of a starboard window. The external visual check of the deck status lights (3-4-2) is not a vital link at this stage of the mission so its displacement from the primary visual envelope is not a major concern.

At task 3-6 the pace of the mission picks up. Its links show an excellent narrow envelope, indicative of proper display and control arrangement. But, a burdensome situation appears at the right hand control lever. Simultaneous tension control and communication tasks could cause performance errors. In addition, multiple checks of the Internal indicators are removing the operator's attention from the primary visual envelope. The emergency task (3-6E) appears to have an adequate link arrangement if the deck status light check is still considered non-vital.

The links in task 3-7 illustrate the same discrepancies as in task 3-6. The emergency wave-off task, though, shows that the operator could be faced with a degraded performance

situation. Clearance restrictions, simultaneous tension control and communication tasks, and displaced internal indicator checks could all cause an overloading situation for the operator.

At task 3-8 the pace has slowed down a little and visual envelopes can be widened, which allows the external visual link to the tail probe (3-8-6) to be acceptable. The rest of the links in this task appear satisfactory.

C. APPLICATION OF RESULTS

The various discrepancies noted in each of the three frames of reference may be used as material for immediate T&E discrepancy reporting or as material for the development of the operator interviews. With respect to the interviews, the link analysis discrepancies contribute specific questions to go along with the questions addressing the range of variables mentioned in chapter II for the particular system being evaluated. In the Recovery Assist analysis, discrepancies dealing with perspective, frame restrictions, and operator workloads may be unconsciously overlooked by an operator during his Functional Mock-up tests and subsequently in his interviews. Specific questions in relation to these problems would make the operator aware of them and as a result provide a measure of each problem's severity.

V. OPERATOR INTERVIEWS

A. QUESTIONNAIRE DEVELOPMENT

The 1978 Navy Personnel Research and Development Center publication, "Human Factors in Operational System Testing: A Manual of Procedures" (Ref. 7) was the exclusive guide in the development of the questionnaire (Appendix D). It provided the general approach and many of the specific questions to ensure adequate coverage of the Mock-up's HFE concerns.

The planning of its contents and the eventual results of the interview had to avoid a major biasing factor for this particular practical and illustrative application of Integration Analysis. All of the operators interviewed had obtained their LSO Console Station experience during either the OPEVAL or TECHEVAL tests of the RAST. Therefore, many of their responses and observations would be much more extensive than if they had only worked with a Functional Mock-up. This forced the interviewer to avoid questions pertaining to environments or situations not possible with a mock-up and to disregard answers that went beyond the scope of a mock-up's capabilities.

The questionnaire development also faced an excessive time delay from last operation to actual interview. Not only was it impossible to interview each operator after the completion of each individual mission, the interviewer also had to accept intervals up to 6 months between operation and interview.

In retrospect, the time delay problem offers a supportive argument for increased use of Mock-up interviews. Such interviews can be easily conducted after each operation, minimizing the possibility of incomplete appraisals that are probable with time delays.

B. QUESTIONNAIRE CONSTRUCTION

The problems of at-sea operation bias and time delays necessitated a preliminary operator information section to enable the interviewer to assess the operator's experience (see Appendix D). In the preferred situation of conducting interviews after each Mock-up operation, information such as weather, time of day, physical characteristics of the operator, and experience in that mission would be applicable.

The interview begins with all encompassing General questions to allow the respondent to focus on the most important difficulties he experienced. Keep in mind, each interview should be conducted after each mission. All four RAST missions are addressed at once due to the circumstances mentioned in Questionnaire Development.

The General questions should make the respondent consider outstanding difficulties, personnel coordination (if applicable), task procedures, complexities, fatigue, training, equipment reliability, and equipment availability and usage (Ref. 7). Such questions allow the respondent to select what he considers the most important topics. They also help him to reflect on difficulties that may arise for less skilled operators and,

thus, assess procedures and complexities of various tasks. The General equipment questions may cause the operator to notice unnecessary, missing, or unreliable equipment.

The Specific questions follow the General questions, but if a General question generates a response to a Specific area, the interviewer should logically proceed to that area. Inflexible interviews may cause incomplete appraisals. The first Specific area deals with Equipment Characteristics of controls and displays. Then the Environment of the work station is addressed to assess habitability and restrictions to performance. A logical follow-on to that is Job Aid adequacy. Safety, Manning requirements, Training assessments, and the ability to gather and disseminate Information required to complete each task are then addressed. Finally, the specific discrepancies noted through the Link Analysis are asked. Those questions would hopefully be answered before this final section, but are included as a double check.

C. RESULTS

There were eight operators interviewed, all with considerable experience, using the questionnaire in appendix C. The following is a list of their discrepancy responses with respect to the Recovery Assist mission. The numbers in parentheses indicate the percentage of operators that answered with that response. Responses listed under a Specific section were drawn out by reference to that Specific area and would have been otherwise overlooked.

I General Question Discrepancies

(* = not mentioned in Appendix A)

1. Difficult communication and tension control coordination (75%)
2. Inadequate ventilation (75%)
3. (*) Port RSD obstructed by deck slope (50%)
4. (*) Perspective for centering (62%)
5. Sun in eyes when looking on horizon (50%)
6. Starboard vision needed (62%)
7. Communications bad when A/C in hover/on deck (62%)
8. Cable hard to see at night (37%)
9. Glare on console panel (75%)
10. Interior lighting inadequate (50%)
11. (*) Hook up crew gets tangled in cable (50%)
12. Need NATOPS holder and grease board (62%)
13. Need a seat (100%)

II Equipment Characteristics

1. Windshield wiper controls hard to operate (100%)
2. (*) Friction lock on Tension Control needed (25%)
3. (*) Better control/display description (25%)
4. (*) Need centering display (50%)
5. (*) Need ship speed indicator (25%)

III Environment (all mentioned in General questions).

IV Job Aids (all mentioned in General questions).

V Safety

1. Need escape door (88%)

VI Manning

1. (*) Two person limit in station (62%)

VII Training (adequate)

VIII Information

1. Can not see if Main Probe in RSD on landing (88%)

IX Communications (all mentioned in General questions).

X Link Analysis Inputs

1. Perspective problem (62%,yes)
2. Starboard window needed (62%)
3. (*) Frame restrictions (100%)
4. Communication and Tension Control problem (75%)
5. Indicator placement change needed (38%)

VI. COMPARISONS AND CONCLUSIONS

The Operator Interviews drew out numerous discrepancies in the General question section alone. This demonstrates the advantage of giving representative operators an opportunity to critique the system before major construction begins. Once the obvious problems had been revealed, the Specific questions brought out discrepancies in the realm of unconscious compensation.

The five Link Analysis inputs contributed even further to unconscious compensation. Frame restrictions and placement of the wind, ship heading, and pitch and roll indicator discrepancies were not noted through the use of the General or Specific questions.

As assessment of the Task Analysis used in both the Link Analysis and the Functional Mock-up operations was given tentative approval as evidenced by the minimal amount of discrepancies relating to procedures and information availability. The need for better A/C centering information and main probe position indication on landing were the only major problems.

Overall, there were 21 discrepancies noted in General and Specific questions, plus two additional discrepancies not noted by the operator interviews, but detected by link analysis. Compared to the discrepancies relating to a Recovery Assist mission in appendix A, Integration Analysis

identified all of the TECHEVAL discrepancies and most of the Mock-up Review changes. Items 1, 2, 7, 10, and 12 of the Mock-up review were overlooked. But, Integration Analysis discovered the 9 additional problems that were noted in the Questionnaire Results. The major additions included the need for a centering display, frame restrictions, and the inability to see the Port RSD due to deck slope.

When the analysis was conducted for all four missions, additional discrepancies were once again noted as compared to appendix A, but the same Mock-up review changes were still missed. Major additions include:

1. Frames obstruct visibility for Deck operations (62%)
2. No indication of slow to fast traverse selection (50%)

The results to the analyses for the other three missions required separate task and link analyses and categorization of the proper responses in the interviews for the applicable mission.

The conclusions to the analysis are biased by the fact that the operators had at-sea experience. In addition, many of those operators had major inputs into appendix A, which obviously helps to correlate the results. But, their responses were included in this analysis only if applicable to Functional Mock-up capabilities.

The promising aspect of this proposed technique is that it produced additional discrepancies. The analysis is also conducted at a relatively low cost compared to an OPEVAL or

TECHEVAL. Further, the system has only progressed through approximately 40% of the Acquisition Cycle when Integration Analysis becomes applicable as compared to about 80% at the TECHEVAL/OPEVAL stage. The recent trend of excessive time in the later phases of the Acquisition Cycle is mainly due to the numerous design changes. Integration Analysis can alleviate this problem through its early inception and expedite the whole Acquisition Cycle.

Integration Analysis also offers a check of equipment characteristics, environments, safety, training, manning, and information acquisition well before Full Development is scheduled. Plus, it can be used as an inexpensive, minimum time, iterative process that can evaluate major and minor HFE changes to a system. Although not addressed here, it can also be used to check maintenance considerations such as accessibility, reliability, and repair procedures (Ref. 7).

Integration Analysis is actually a formal combination of techniques that should be used in every System Acquisition T&E process. Its early introduction into the process and its inherent use and refinement of critical analysis techniques makes it a viable and important step in System Acquisition cost reduction and the attainment of optimal designs.

APPENDIX A

LSO CONTROL STATION TECHEVAL DISCREPANCIES

1. Complexity of the maneuvering and straightening procedures due to the multiple switching tasks required by the LSO, his inability to see the flight deck alignment markings, and the lack of visual feedback when maneuvering the helicopter.
2. Inefficient design of the RSD Brake switch on the LSO console, which required that the switch be held in the AUTO or RELEASE position.
3. Lack of an indication at the LSO station that the aircraft RAST main probe is captured by the RSD arresting beams.
4. Remote location of the roll indicator in the station which precludes continuous scanning.
5. Inappropriate longitudinal and rotational movements of the TRAVERSE handle on the LSO control console, in relation to aircraft orientation.
6. Absence of rearward FOV from the LSO station.
7. Constant low frequency hum in the LSO headset.
8. Inadequate night lighting of the interior of the LSO station.
9. Undesirable crosstalk between the LSO UHF and 1JG communications circuits during simultaneous transmissions.
10. Absence of provisions for stowage of manuals and operator checklists in the LSO station.
11. Inability of the LSO and flight deck crewman to see the messenger cable and end fitting at night.
12. Inability of the LSO to communicate on the radio or sound-powered phone circuits during maneuvering and straightening due to the requirement to use both hands to operate other controls.

RECOMMENDED MOCK-UP REVIEW CHANGES

1. Reposition the LSO console 4" to the right and lower its height 3" so it can be recessed forward.
2. Relocate all communication systems from the aft bulkhead to the forward and port bulkheads.
3. Install a 12" X 32" window in the rear bulkhead.
4. Group all window washer/wiper/heater controls on the starboard bulkhead above the entrance ladder.
5. Install Grimes lights above the LSO console and in each corner of the rear bulkhead.
6. Install a storage compartment for NATOPS/procedure notebooks and a fold-down seat on the rear bulkhead.
7. Install a writing surface (plexiglass with white background) above the LSO console.
8. Reverse the pitch and roll indicators.
9. Relocate the wind direction/velocity indicator to the forward port corner of the LSO station.
10. Reposition the crash alarm from the port bulkhead to the forward port corner of the LSO station above the wind direction/velocity indicator.
11. Tint the upper and aft (when incorporated) control station windows.
12. Incorporate an operator-adjustable volume control on the 1MC loudspeaker.
13. Incorporate noise-cancelling microphones in the control station and eliminate the UHF/ICS crosstalk.
14. Install an emergency escape exit.
15. Install a dual action (UHF/1JG) footswitch.
16. Increase the ventilation capacity in the control station.

APPENDIX B

TASK ANALYSIS
MISSION: RECOVERY ASSIST

CONDITIONS:

- A. LSOCC Configured for system start-up
- B. Remote control of RAST system established
- C. Power-on LSOCC Indicator check complete
- D. RSD in position on flight deck
- E. Flight deck and crew prepared for Recovery Assist

TASK: 3.1 Communications Checks						
SUBTASK	ACTION	KNOWLEDGE/ INFORMATION	CONTROL	DISPLAY	POSSIBLE CONSTRAINTS	ERROR IMPACT
3.1.1 Verify Internal Comm	Call LSE, HCO, BRIDGE	Stations manned	IC/RADIO Switch			Delay in Mission
3.1.2 Verify UHF Comms.	Call Aircraft	Proper Radio, selected	IC/RADIO Switch		EMCON	Delay in Mission
TASK: 3.2 Obtain Bridge Clearance						
3.2.1 Set Switch on Bridge Info. Panel	Turn switch to RECOVER	Crew and Deck ready	Bridge Info. switch			Delay in Mission
3.2.2 Press Clearance Req. Button	Press SEND Button		SEND Button	Button Illum.		Delay in Mission
3.2.3 Verify Bridge Info. YES indicator lit	Visual			Bridge Info. Panel	Indicator Illumination	Delay in Mission

TASK: 3.3 RA CABLE DEPLOYMENT						
SUBTASK	ACTION	KNOWLEDGE/ INFORMATION	CONTROL	DISPLAY	POSSIBLE CONSTRAINTS	ERROR IMPACT
3.3.1 Select OUT position on RA CABLE switch	Hold switch in position	System in STANDBY mode	RA CABLE switch	RA Info. Panel	System not in Standby, Inadvertent release	Motor damage, Delays
3.3.2 Verify Cable reeled out	Visual	Cable condition, reeled out 30-40'	IC/RADIO switch, RA CABLE switch		Visual Obstr., Holding CABLE SWITCH	Delay in Mission
3.3.2 Release CABLE switch	Release switch	Cable ready	RA CABLE switch	RA Info. Panel	Visual Obstr.	Delay in Mission
TASK: 3.4 Clear Aircraft for Landing						
3.4.1 Check landing conditions	Check wind,roll pitch	Envelopes, winds,roll, pitch		wind, roll pitch, envelope cards, windsock	card not available, indicators down	Safety Hazard
3.4.2 Select GREEN deck	Turn deck status to GREEN	Landing conditions	selector switch	deck status, hanger lights	light malfunc. indicator illum.	Delay in Mission
3.4.3 Clear A/C for approach	Call A/C, Check area clear	Hazards in area	IC/RADIO switch		Visual Obstr., Radio Failure	Safety Hazard

TASK: 3.5 Hook Up RA Cable

SUBTASK	ACTION	KNOWLEDGE/ INFORMATION	CONTROL	DISPLAY	POSSIBLE CONSTRAINTS	ERROR IMPACT
3.5.1 Direct A/C to lower Main Probe	Call A/C	A/C position, Probe position on A/C	IC/RADIO switch		Visual Obstr.	Delay in Mission
3.5.2 Direct/ signal A/C to lower messenger cable	Call A/C	A/C position over Flight Deck	IC/RADIO switch		Visual Obstr. Pilot Visual contact	Cable tanglement, Safety hazard
3.5.3 Connect messenger cable	Direct Deck personnel	Personnel, cable, and A/C position	IC/RADIO switch		IC failure Visual Obstr.	Safety Hazard to personnel
3.5.4 Select AMBER deck	Turn Deck status to AMBER	Cable hooked up	Selector switch, IC/RADIO switch	Deck status, Hanger lights	Light malfunction, Indicator Illum., Radio failure	Delay in Mission
3.5.5 Direct/ Signal A/C to raise messenger cable	Call/ Signal A/C	A/C position	IC/RADIO switch		Radio failure Visual Obstr., Pilot Visual contact	Delay in Mission
3.5.6 Confirm RA Cable end fitting locked into Main Probe	Call A/C, Visual	Visual Inspect Pilot report	IC/RADIO switch		Visual Obstr. to Main Probe, Radio Failure	Delay in mission Safety Hazard

TASK: 3.6 Establish RA Cable Hover Tension

SUBTASK	ACTION	KNOWLEDGE/ INFORMATION	CONTROL	DISPLAY	POSSIBLE CONSTRAINTS	ERROR IMPACT
3.6.1 Set Cable Tension Lever	Position at RA SLOT	A/C position	Cable Tension lever			Delay in Mission
3.6.2 Verify RA "2FPS" on	Check RA Info. Panel	A/C position		RA Info. Panel	Indicator Illumination	Delay in Mission
3.6.3 Direct/Signal A/C to Standby for Hover Tension	Call/Signal A/C	A/C Position Roll, pitch, wind	IC/RADIO switch	Wind, roll pitch	Observing A/C and checking conditions	Safety Hazard
3.6.4 Switch on "RA SELECT"	Move RA Select switch to "Select"	A/C position Roll, pitch wind	RA Select switch		Right hand stays on Tension Lever	Excess Tension Safety Hazard
3.6.5 Verify slack is reeling in, Check Tension Meter	Visual, Check Tension Meter	A/C position Tension Meter shows 200-400 LBS		Tension Meter	Visual Obstr., Right hand stays on Tension Lever, Cable Fouling	Delay in Mission
3.6.6 Verify RA "2FPS" OFF	Visual	A/C position Tension		RA Info. Panel	Indicator Illumination	Delay in Mission
3.6.7 Direct/Signal A/C to Standby for Hover Tension	Call/Signal A/C	A/C position Roll, pitch, wind, and slack gone	IC/RADIO switch	Wind, roll pitch	Visual Obstr., Indicators Down, Radio failure	Delay in Mission

SUBTASK	ACTION	KNOWLEDGE/ INFORMATION	CONTROL	DISPLAY	POSSIBLE CONSTRAINTS	ERROR IMPACT
3.6.8 Apply Hover Tension	Push Cable Tension lever to 2000 LBS	A/C position Cable condition	Cable Tension lever	Tension Meter	Visual Obstr., Coordination of Radio switch and Tension lever, Cable fouling	Safety Hazard
3.6.9 Center A/C for landing	Call/Signal A/C	A/C position Cable position Tension	IC/RADIO switch		Perspective, Visual Obstr., Radio Failure	Safety Hazard
TASK: 3.6E Emergency Release of RA Cable						
3.6.1e Push START/STANDBY	Push Button	A/C position Cable position Tension	START/STANDBY Button	Tension Meter	Visual Obstr.,	Safety Hazard
3.6.2e Select "RED" deck	Turn deck selector to "RED"	Loss of Tension, A/C position	Selector switch	Deck Status, Hanger	Indicator Illumination	Safety Hazard Delay in Mission
3.6.3e Direct Pilot to release cable	Call A/C	A/C position Cable position	IC/RADIO switch		Radio Failure	Delay in Mission
3.6.4e Direct deck crew to inspect cable	Call/Signal Crew	A/C position Cable position	IC/RADIO switch		Radio Failure Visual Obstr.	Delay in Mission
3.6.5e Select "GREEN" deck	Turn Deck selector to "GREEN"	A/C, Crew, Cable position	Selector switch	Deck Status, Hanger Lights	Indicator Illumination	Delay in Mission

TASK: 3.7 Direct Landing						
SUBTASK	ACTION	KNOWLEDGE/ INFORMATION	CONTROL	DISPLAY	POSSIBLE CONSTRAINTS	ERROR IMPACT
3.7.1 Direct A/C to Standby for RA Tension	Call/ Signal A/C	A/C position over RSD; wind, roll, pitch	IC/RADIO switch		Perspective, Visual Obstr., Radio failure	Safety Hazard
3.7.2 Apply RA Tension	Push Cable Tension lever to 4000 LBS	A/C position; wind, roll, pitch	Cable Tension lever	Tension meter	Perspective, Visual Obstr.	Excess load on A/C; Off center landing
3.7.3 Select "RED" deck for landing	Turn deck selector to RED	A/C position	Selector switch	Deck Status; Hanger lights	Indicator Illumination; Right hand stays on Tension lever	Delay in Mission
TASK 3.7E Emergency Wave-Off						
3.7.1e Press Wave-off Button	Press Button	A/C position; Area Clear of hazards	Wave-off Button	Red light on button	Visual Obstr.; Right hand stays on Tension lever	Safety Hazard
3.7.2e Transmit Wave-off call	Call A/C	A/C position; wind, roll, pitch	IC/RADIO switch		Visual Obstr.; Radio Failure; Coordination of Radio switch and Tension lever	Safety Hazard
3.7.3e Select "MIN" Tension	Pull Cable Tension to "MIN"	A/C, Cable positions	Cable Tension lever	Tension meter	Visual Obstr.	Excess load on A/C
3.7.4e Select RED deck	Turn deck selector to RED	A/C, Cable positions	Selector switch	Deck Status; Hanger lights	Indicator Illumination	Delay in Mission

SUBTASK	ACTION	KNOWLEDGE/ INFORMATION	CONTROL	DISPLAY	POSSIBLE CONSTRAINTS	ERROR IMPACT
3.7.5e Inform A/C "All Clear"	Call/ Signal A/C	Area clear of hazards	IC/RADIO switch		Visual Obstr.; Radio Failure	Safety Hazard
3.7.6e Verify RAST equip. UP	Call RAST room	System goes to STBY when pilot releases	IC/RADIO switch		IC failure	Delay in Mission
TASK 3.8 Secure Helo in RSD						
3.8.1 Verify Main Probe in RSD	Visual	Main Probe position; RSD open			Visual Obstr.	Delay in Mission
3.8.2 Close RSD	Move RSD Beam switch to "CLOSED"	Main Probe position; roll, pitch	RSD Beam switch	RSD Status Panel	Visual Obstr.; Indicator Illumination	Delay in Mission; Damage to Probe
3.8.3 Verify Beams latched, FLAGS up	Visual	Flag locations; Latched appearance		RSD Status Panel	Visual Obstr.; Indicator Illumination	Probe not latched; Safety Hazard
3.8.4 Direct/Signal A/C	Call/ Signal A/C	Probe, RSD positions	IC/RADIO switch	RSD Status Panel	Visual Obstr.; Radio Failure	Delay in Mission
3.8.5 Switch RSD off	Move RSD Beam switch to OFF	Probe, RSD positions	RSD Beam switch		No display for RSD OFF	Delay in Mission
3.8.6 Direct pilot to lower tail probe, confirm down	Call/ Signal A/C	Tail Probe position	IC/RADIO switch		Visual Obstr.	Delay in Mission

SUBTASK	ACTION	KNOWLEDGE/ INFORMATION	CONTROL	DISPLAY	POSSIBLE CONSTRAINTS	ERROR IMPACT
3.8.7 Select MIN tension	Pull Cable Tension lever to MIN	A/C and Tail Probe positions	Cable Tension lever	Tension meter	Visual Obstr.	Safety Hazard
3.8.8 Put System in "STANDBY"	Push START/ STANDBY button	A/C secured	START/ STANDBY button	System Status Panel	Indicator Illumination	Delay in Mission
3.8.9 Inform Bridge A/C secured	Call Bridge	A/C secured	IC/RADIO switch		IC failure	Delay in Mission

APPENDIX C

EVC

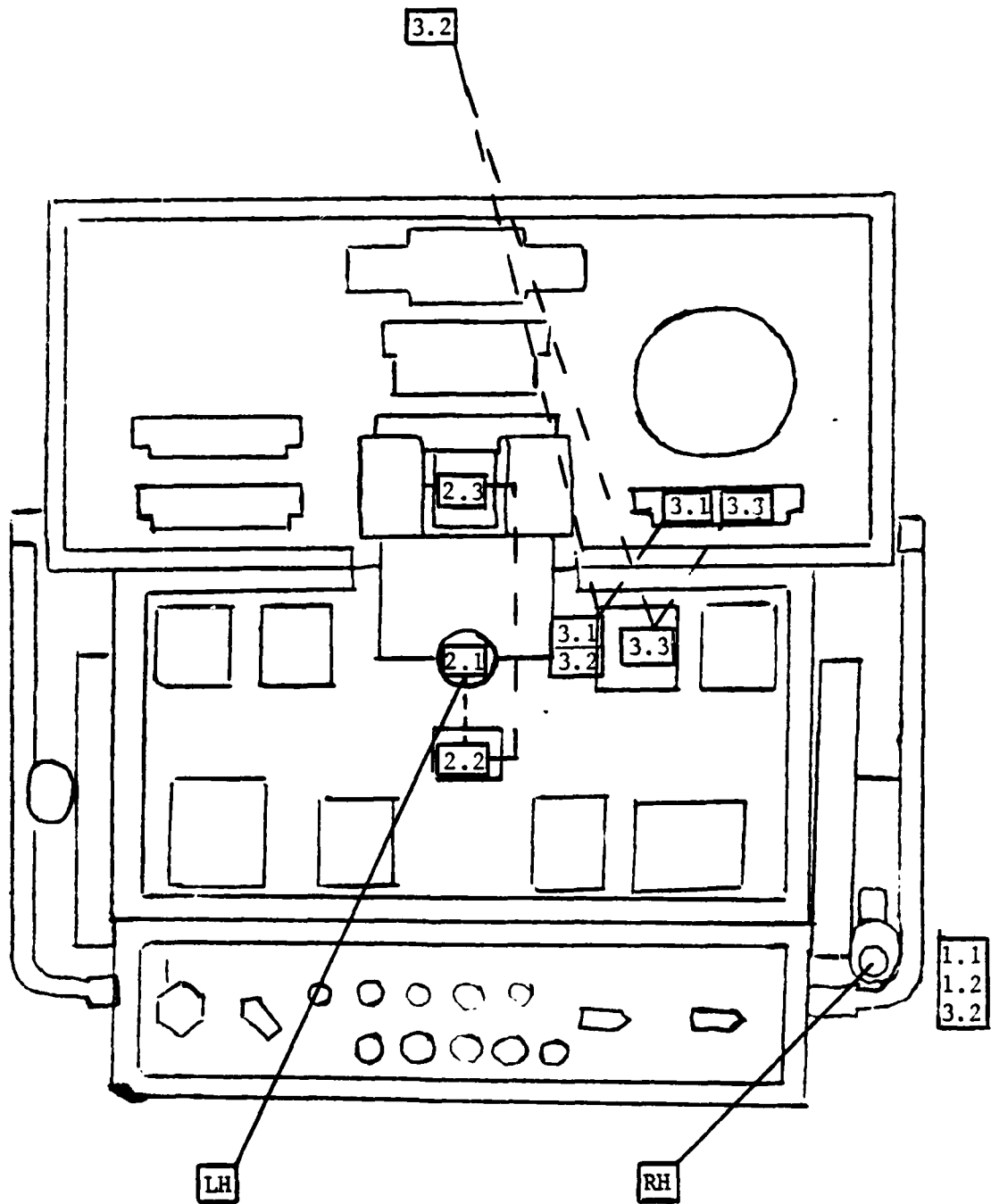

TASK: 3.1-3.3

Communications Checks- RA Cable Deployment

EVC= External Visual Check on Deck

- - - Visual Link

— Manual Link

$\frac{3.1}{3.2}$ = Continuous Action

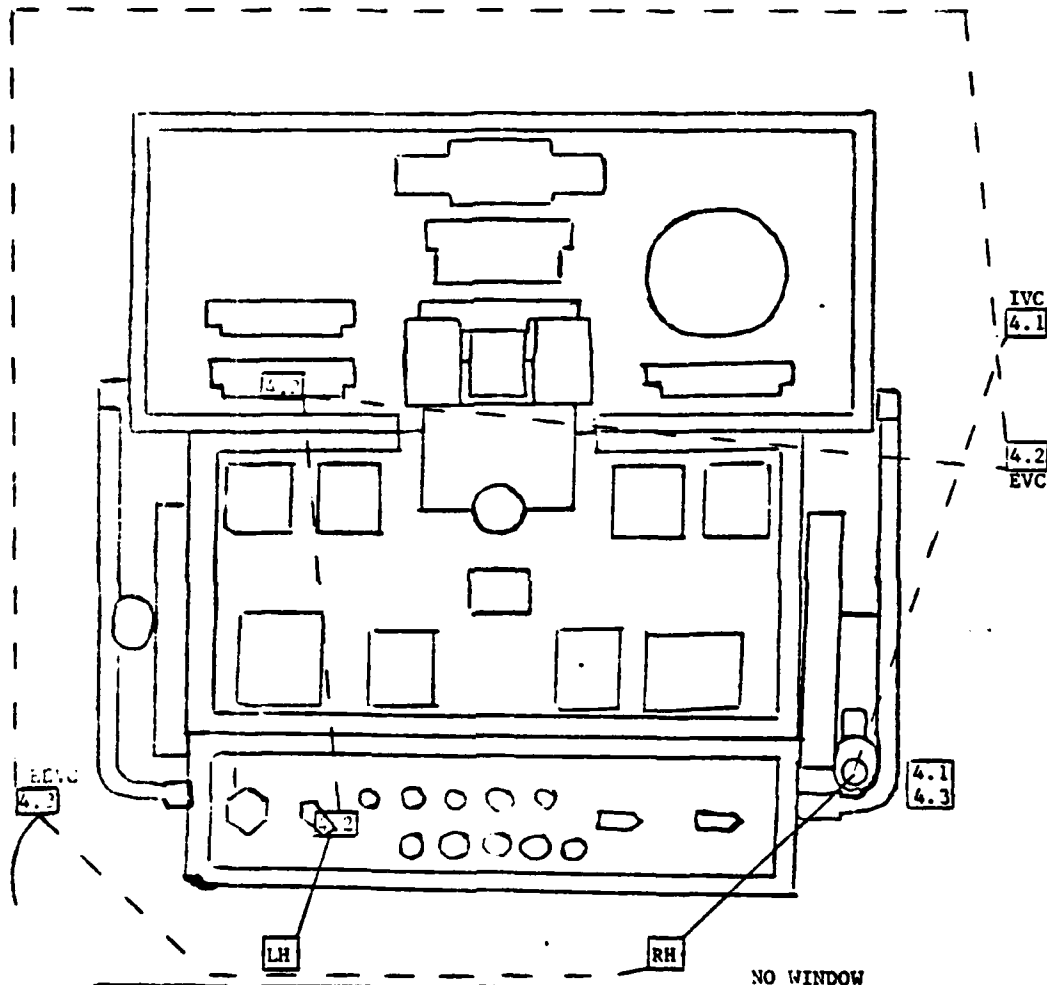

TASK: 3.4

Clear Aircraft For Landing

EVC= External Visual Check on Deck; IVC= Internal Visual Check

EEVC= External Visual Check, Elevated

- - - Visual Link

-----> Manual Link

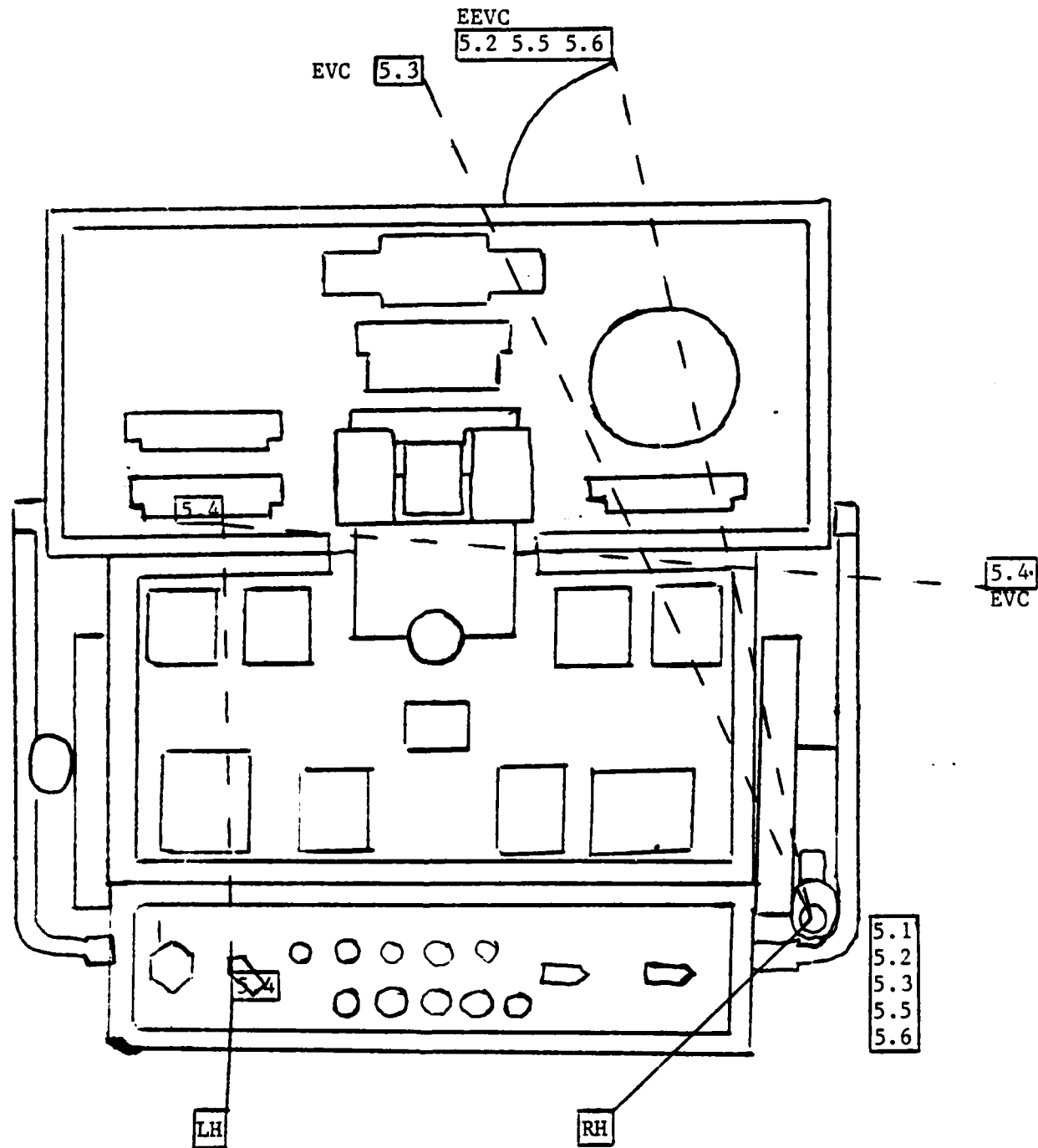

TASK: 3.5
 Hook Up RA Cable
 EVC= External Visual Check on Deck
 EEVC= External Visual Check, Elevated
 - - - Visual Link
 ——— Manual Link

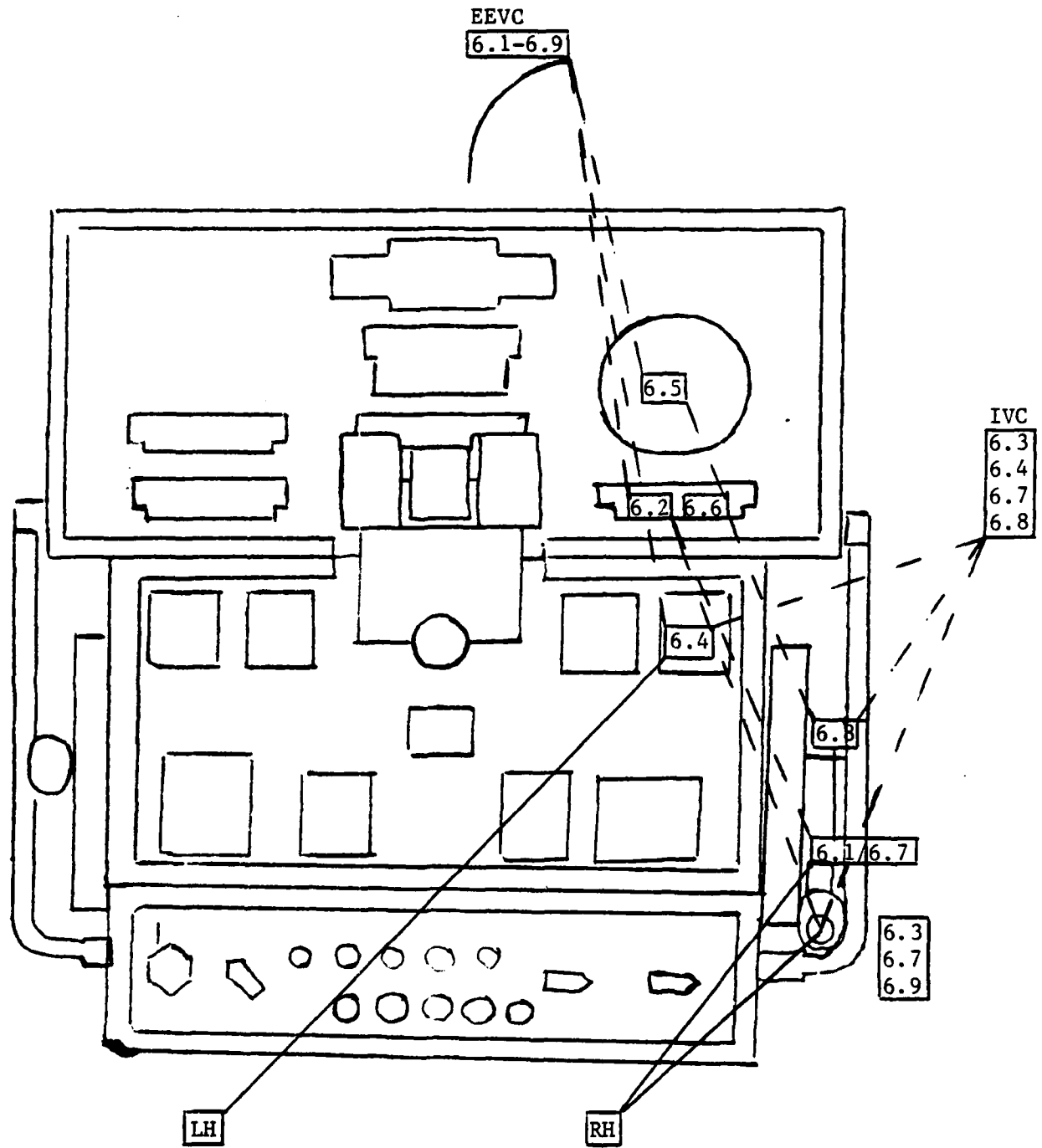

TASK: 3.6
Establish RA Cable Hover Tension
 EEVC= External Visual Check, Elevated
 IVC= Internal Visual Check
 6.1/6.7= Continuous Action
 - - - = Visual Link
 ——— = Manual Link

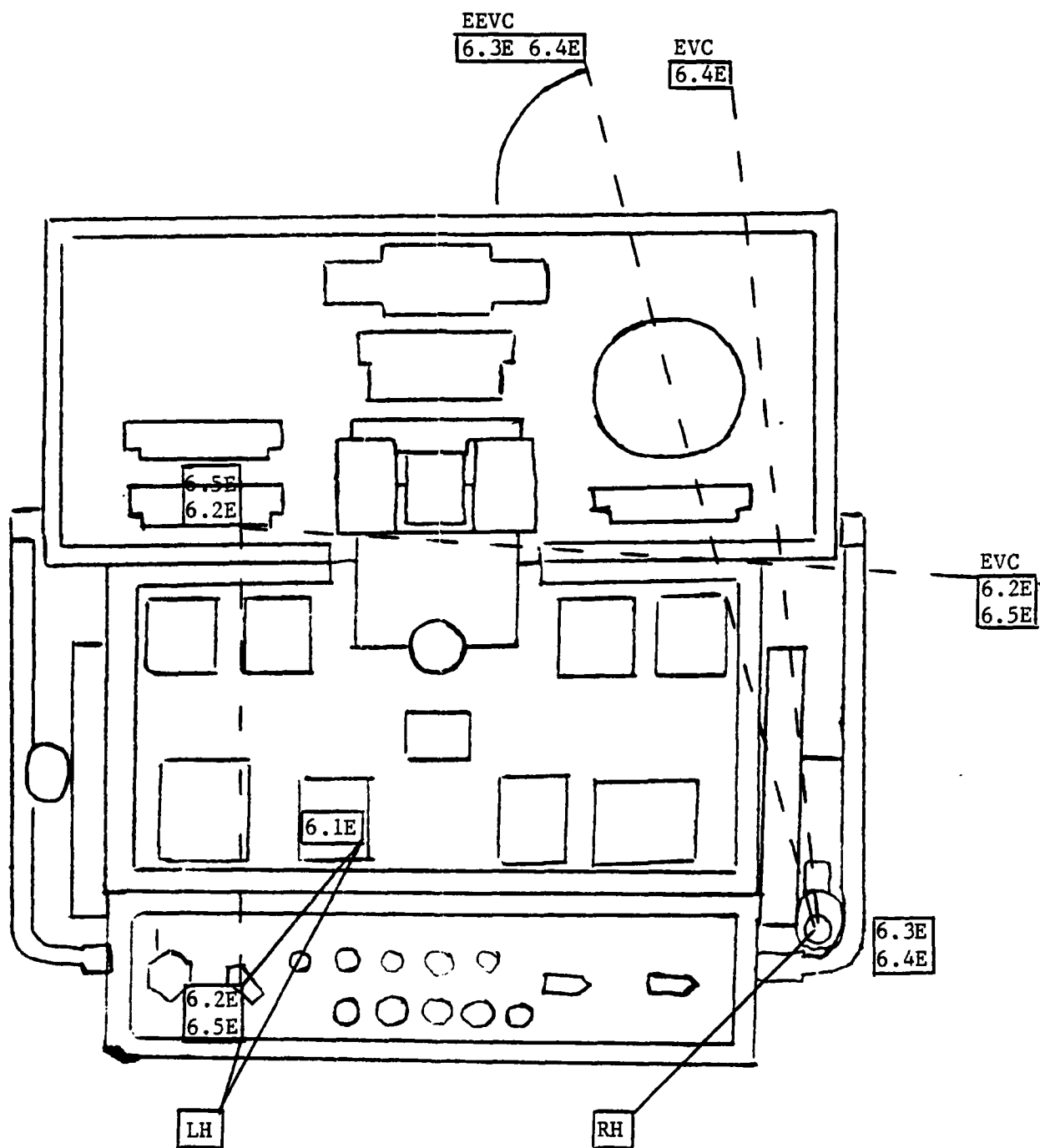

TASK: 3.6E
 Emergency Release of RA Cable
 EVC= External Visual Check on Deck
 EEVC= External Visual Check, Elevated
 - - - Visual Link
 ——— Manual Link

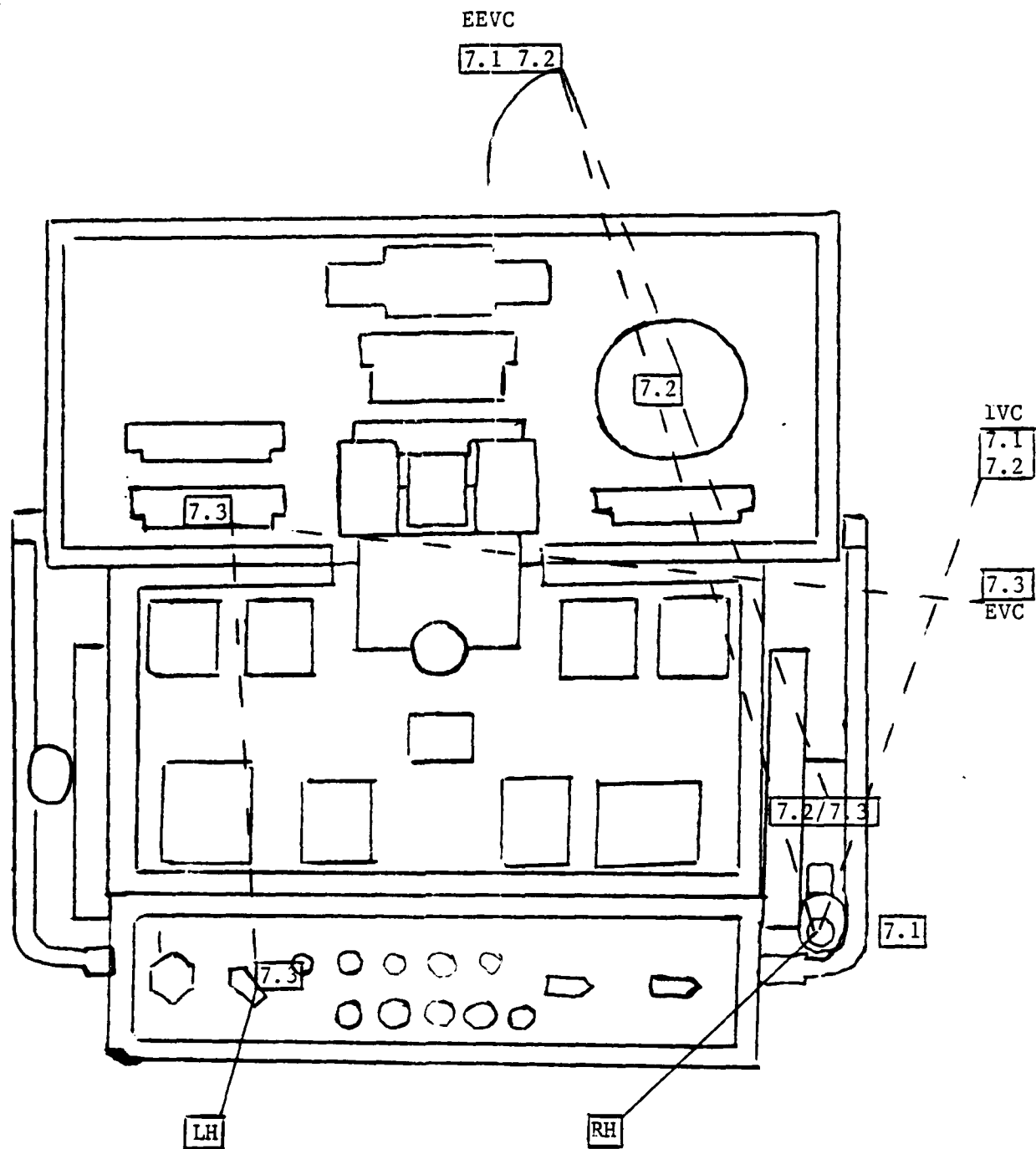

TASK: 3.7

Direct Landing

EVC= External Visual Check on Deck

EEVC= External Visual Check, Elevated

IVC= Internal Visual Check

7.2/7.3= Continuous Action

- - - = Visual Link

— = Manual Link

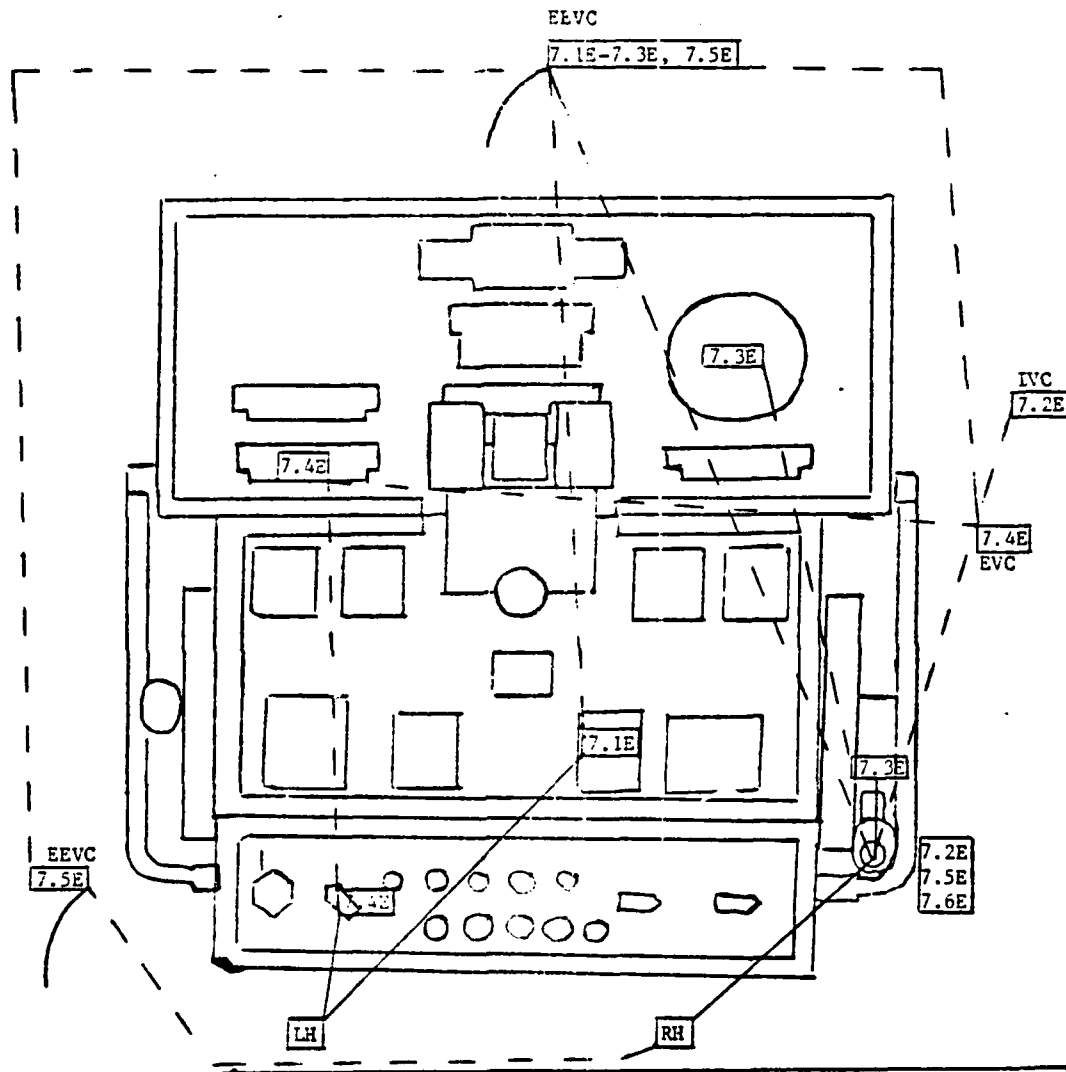

TASK: 5.7E
 Emergency Wave-Off
 EVC= External Visual Check on Deck
 EEVC= External Visual Check, Elevated
 IVC= Internal Visual Check
 - - - Visual Link
 ——— Manual Link

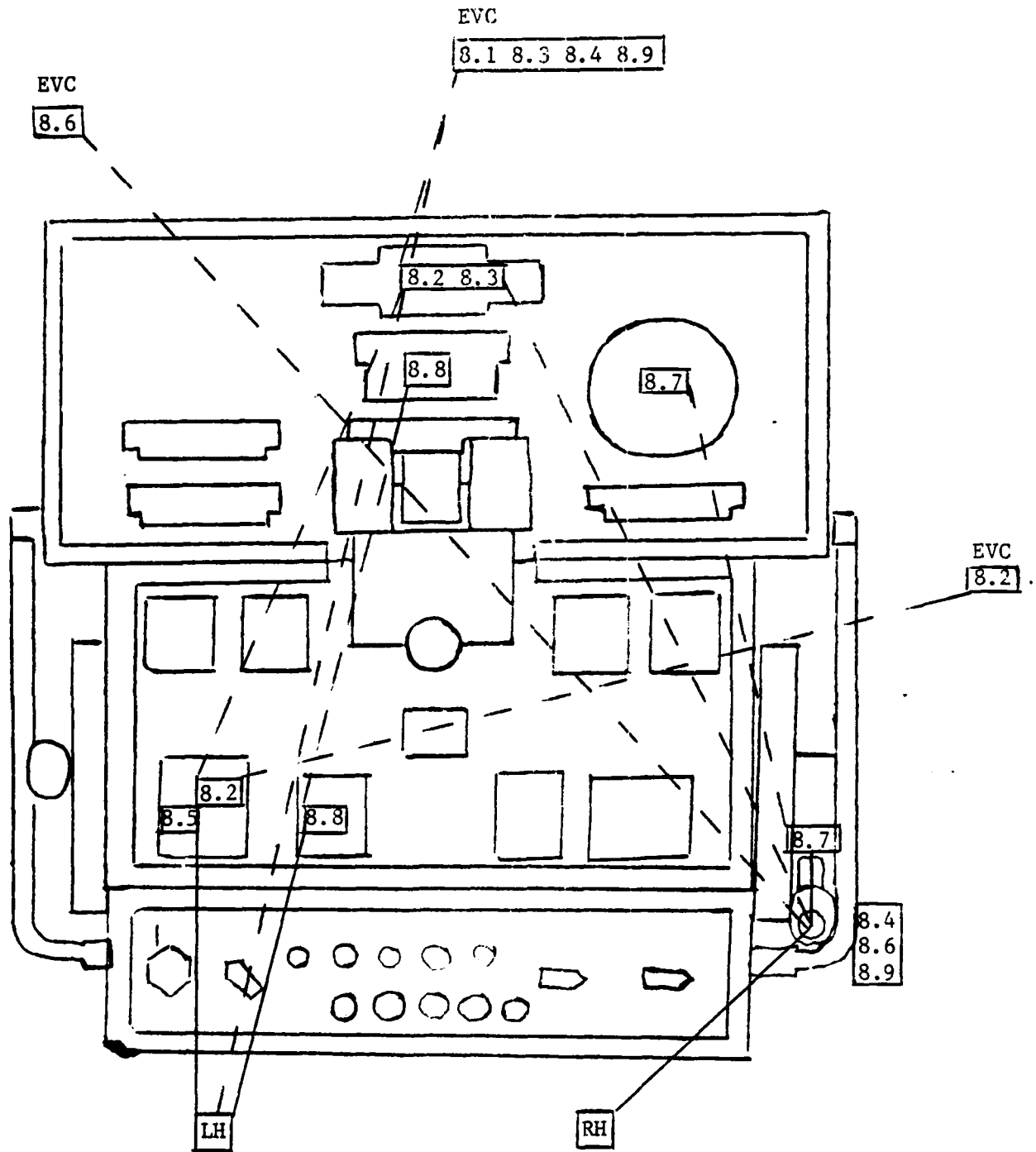

TASK: 3.8
 Secure Helo in RSD
 EVC= External Visual Check on Deck
 - - - - Visual Link
 ——— Manual Link

APPENDIX D

RAST System's LSO Control Station Questionnaire

Interviewer - LT. David Carlson

PURPOSE

This questionnaire is designed to accompany interviews that will attempt to elicit the opinions of experienced operators concerning the Human Factors Engineering design of the LSO Control Station. The data and comments resulting from the interviews will be used to help reveal problem areas associated with the stations present design.

I Operator Information

1. Name - _____
2. Height - _____
3. Date last operated RAST - _____
4. Present date - _____
5. How many times have you operated the RAST system during:
 - a) Clear weather, day
 - i) Traversing = _____
 - ii) Flight Ops = _____
 - b) Rain, day
 - i) Traversing = _____
 - ii) Flight Ops = _____
 - c) Clear weather, night
 - i) Traversing = _____
 - ii) Flight Ops = _____
 - d) Rain, night
 - i) Traversing = _____
 - ii) Flight Ops = _____

II General Questions: Ask each question in relation to all 4 missions: Traversing, Launch, Recovery, and Maneuvering and Straightening.

1. Can you recall any problems (no matter how small) you experienced during your operation of the RAST? If so, what? What do you think was responsible? What action did you take?

Comments:

2. Did you observe anyone else having problems? If so, what? What did that person do to relieve the problem?

Comments:

3. Did the test operation as a whole, or your job during the test, take much longer than you had expected it to take? Do you know why? Did this extra time affect your performance in any way?

Comments:

4. Can you think of any changes in equipment or procedures that must be made to accomplish the mission?

Comments:

5. Could you operate the equipment in accordance with the procedures you had been taught? If not, did you add any steps? Delete any steps? Perform one or more steps differently?

Comments:

6. Assume that someone less skilled than you had to do your job. Would there be anything about the equipment, procedures, or the mission as a whole that would cause a less skilled man difficulties?

Comments:

7. Were there any characteristics of the mission, such as equipment, procedures, technical manuals, etc., that made it difficult to complete your tasks? How do you know that you had more than your usual difficulty?

Comments:

8. Did the equipment fail in any way to perform as it was supposed to do (in any respect, no matter how small)? If so, do you know why? What did you do in reaction?

Comments:

9. Is every part of the equipment necessary?

Comments:

10. Did you experience any difficulty as a consequence of operating the RAST for a prolonged period of time?

Comments:

III Equipment Characteristics: Ask each question in relation to all 4 missions; Traversing, Launch, Recovery, Maneuvering and Straightening.

1. Were the controls difficult to operate? Any particular controls? Do you know why the controls are difficult to operate? How does the difficulty show itself (mushiness, illogical movement)? What was the effect of the difficulty on your performance?

Comments:

2. Were any of the controls difficult to reach? How important are these controls? What effect does this difficulty have on your performance?

Comments:

3. Were any of the displays (meters, indicators) difficult to read? How important are these displays? Why were they difficult to read? What was the effect on your performance?

Comments:

4. Did the displays provide all the information needed to do the job? What information was missing? Was there too much information?

Comments:

5. Were any of the displays difficult to understand? What precisely about the displays was difficult to understand?

Comments:

6. Did you have any difficulty reading the lettering or indicator lights when they were unlit? Lit?

Comments:

7. Did any of the controls or displays seem unnecessary to perform the job? Are other controls or displays needed?

Comments:

IV Environment: Ask for each mission.

1. Was the lighting in the station inadequate at any time for you to operate with maximum efficiency? Too little lighting? Too much lighting (Glare)?

Comments:

2. Was the station excessively noisy, improperly ventilated, too cool, or too warm? How did this affect your performance?

Comments:

V Job Aids: Ask for each mission.

1. Are the manuals, checklists, and aid equipment you need for proper performance available? Are there any aids you might need that are not available to you?

Comments:

VI Safety: Ask for each mission.

1. Is there any safety equipment you need that has not been provided?

Comments:

2. Are there any desirable safety features that have not been included in the design of the station? What are these features? How important are they?

Comments:

3. Are there any safety hazards in the station that you noticed? If so, what? Is all safety information conspicuously posted?

Comments:

4. Are all required safety equipment available and accessible in the station? If not, what?

Comments:

VII Manning: Ask for each mission.

1. Could you have used more men to do the job than were assigned to your team? If so, how many and of what type and what skill level should they have been? Could you have used fewer men to do the job? If so, which ones would you eliminate?

Comments:

2. Was anyone on your team overloaded? Why?

Comments:

VIII Training: Ask for each mission.

1. Do you feel that the training you were given for this job was appropriate? What do you recommend to improve training?

Comments:

2. Are the men in your team properly qualified in terms of training?

Comments:

3. What items were missing from the training you received that should be added? Did you receive enough training to do the job?

Comments:

4. What parts of the training were most important for safe, efficient operation?

Comments:

IX Information: Ask for each mission.

1. Do you feel that the procedures for operating the equipment are completely adequate? Does it reflect what you have to do? Does it cover all contingencies?

Comments:

2. Is it difficult to obtain information at any time to complete a task? If so, what information? Why?

Comments:

X Communications: Ask for each mission.

1. Did you have any difficulty in receiving or supplying information to other personnel over ICS? UHF? If so, what? How can these be changed?

Comments:

2. Did the necessity to communicate interfere in any way with your job of operating the equipment?

Comments:

XI Link Analysis Inputs

1. Did you encounter a perspective problem while trying to place the A/C over the RSD? If so, in what direction(s)? How did you correct for it?

Comments:

2. Did you feel that the lack of a starboard window degraded your performance? If so, how?

Comments:

3. Did you encounter difficulties in visual obstructions due to the station's structure? If so, how? In what directions?

Comments:

4. Did simultaneous tension control and communication tasks degrade your performance? If so, how? How did you compensate?

Comments:

5. Are the wind speed, velocity, pitch and roll, and ship heading indicators adequately located? If not, how should they be positioned?

Comments:

LIST OF REFERENCES

1. Essex Corporation Report under contract N00024-76-C-6129, Subject: Final Report on Human Factors Engineering Technology Applied to the Beartrap Recovery Assist, Secure and Traverse (RAST) System LSO Console Design, by T. B. Malone, D. R. Eike, June 1978.
2. Pacific Missile Test Center Report TP-76-11C, Human Factors Test and Evaluation Manual Volume III Methods and Procedures, by T. B. Malone, S. W. Shenk, and William F. Moroney, 1 October 1976.
3. Pacific Missile Test Center Report TP-76-11A, Human Factors Test and Evaluation Manual Volume I Data Guide, by T. B. Malone, S. W. Shenk, and William F. Moroney, 1 October 1976.
4. Department of Defense Directive 5000.2, Subject: Major System Acquisition Procedures, 19 March 1980.
5. Huchinson, R. D., New Horizons for Human Factors in Design, McGraw-Hill, 1981.
6. McCormick, E. J., Human Factors in Engineering and Design, McGraw-Hill, 1972.
7. Navy Personnel Research and Development Center, Human Factors in Operational System Testing: A Manual of Procedures, April 1978.
8. Commander Naval Air Test Center Report RW-30R-81 to Commander Naval Air Systems Command, Subject: NATC Technical Report RW-30R-81, LAMPS MK III Test and Evaluation Phase I, Navy Preliminary Evaluation (NPE-IB) and SH-60B/FFG-8 Shipboard Envelope Development/RAST Technical Evaluation, Final Report, 14 September 1982.
9. Allen Corporation of America Technical Report prepared for Naval Air Development Center, Subject: Task Analysis and Design of a Landing Safety Officer (LSO) Training Program for the LAMPS MK III/Recovery Assist, Secure and Traverse (RAST) System, 24 February 1982.
10. Commander Naval Sea Systems Command (PMS 399) letter PMS 339.11/RDT, Serial 1/313 to Commander Naval Air Systems Command (PMA/PMS 266) Subject: LAMPS MK III Installation Aboard FFG-7 Class Ships, Arrangement of RAST Control Station, Enclosure: Copy of Gibbs and Cox Report of RAST Control Station Review Conference of 11 March 1981, 20 July 1981.

11. RAST Operation and Maintenance Instruction Manual,
AD-700A0-OMI-010, Chapter 2, 15 April 1981.
12. USS McInerney Instruction 5400.1, Chapter 8, Helicopter
Operations Bill, 20 October 1981.
13. Naval Aviation Engineering Center RAST System Simulator
Training Instructions, Chapters 1 and 2, undated excerpts.

INITIAL DISTRIBUTION LIST

	No. Copies
1. Defense Technical Information Center Cameron Station Alexandria, Virginia 22314	2
2. Superintendent ATTN: Library, Code 0142 Naval Postgraduate School Monterey, California 93940	2
3. Superintendent ATTN: Department of Operations Research Code 55 Hu Naval Postgraduate School Monterey, California 93940	4
4. Commanding Officer ATTN: CDR W. F. Moroney, USN Systems Engineering Test Directorate (SY 70F) Naval Air Test Center Patuxent River, MD 20670	1
5. Commander, Naval Sea Systems Command ATTN: Mr. R. Toman and Mr. A. Mensforth PMS 399 Naval Sea Systems Command Headquarters Washington, DC 20362	2
6. Commanding Officer ATTN: Mr. A. Weaver RWATD (RW70) Naval Air Test Center Patuxent River, MD 20670	1
7. Department Chairman, Code 55 Department of Operations Research Naval Postgraduate School Monterey, California 93940	1
8. LT David L. Carlson 616 Bluffview Rd Spring Valley, CA 92077	1

END

FILMED

5-83

DTIC