

AD-A128 489

THE IMPACT OF LOW COST COMPUTING TECHNOLOGIES ON THE
DEPARTMENT OF DEFENSE TECHNOLOGY TRENDS UPDATE(U) YOUNG
(ARTHUR) AND CO WASHINGTON DC 18 APR 83

1/1

UNCLASSIFIED

F/G 5/1

NL

END
DATE
FILMED
6 83
DTIC

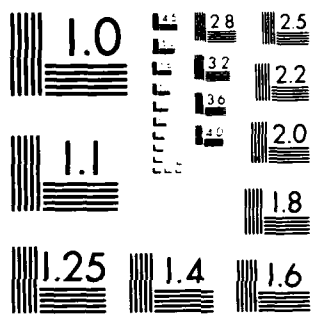

MICROCOPY RESOLUTION TEST CHART
NATIONAL BUREAU OF STANDARDS-1963-A

12

The Impact of Low Cost Computing Technologies on the Department of Defense

Department of Defense



DTIC
ELECTE
MAY 24 1983
S H D

DTIC FILE COPY

Technology Trends Update

ARTHUR YOUNG

DISTRIBUTION STATEMENT A
Approved for public release;
Distribution Unlimited

83 05 10 040

ARTHUR YOUNG

April 18, 1983

Mr. Harry Pontius
Office of the Assistant Secretary
of Defense (Comptroller)
Directorate of Information Resources
Management Systems
Room 3A336
The Pentagon
Washington, D.C. 20301

12
MAY 24 1983

Dear Mr. Pontius:

Many years after the introduction of large-scale integrated microprocessor chips, the impact of this technology break-through continues to reverberate through the market place. Triggered by technological advances, the interaction of technology, market forces, and management remains dynamic. Technology continues to be the source of management's hope for enormous improvements in productivity and overall effectiveness of operations. Yet it is also the source of management's greatest current challenge: determining how to adapt a work force and management structure designed for an earlier era to meet the needs of the new information technology era.

The Directorate for Information Resources Management Systems (DIRMS) in the Office of the Assistant Secretary of Defense (Comptroller) has concentrated, over the past year, on analyzing technology advances and resulting management needs in the Department of Defense. DIRMS contracted with Arthur Young & Company to explore the potential impact of low cost computing technology on DoD and to assist in the development of a management strategy designed to take advantage of the new technology.

The resulting project has been conducted in three phases. During the first phase, Arthur Young & Company examined technology developments and trends and assessed their implications for DoD. A preliminary series of management issues and concerns were identified. The second phase encompassed an analysis of private industry approaches to resolving the management issues identified, and an assessment of current strategies in the military services. This report is the final product of the second phase. In the third phase of the project, Arthur Young will work with DIRMS to develop a comprehensive approach for low cost computing, addressing policy and program initiatives for DoD.

DISTRIBUTION STATEMENT A

Approved for public release;
Distribution Unlimited



✓	File 12-182 or file	by Codes	and/or	(1)
---	---------------------------	----------	--------	-----

→ The key findings in the second phase of our technology trend study are those that have long-term implications for the Department of Defense. These findings can be summarized by the following technology factors which characterize the low cost computing environment:

A

- . The move towards end user computing and away from traditional data processing organizations
- . Dispersion of information processing resources and capabilities which parallel the shift to end user computer
- . Merging of previously separate technologies for data processing, office automation and telecommunications
- . Continuing, dramatic improvements in price/performance ratios for both hardware and software, coupled with extraordinary volumes of sales,
- . The rapid rate of technological change which makes product life cycles much shorter than in the past.
- . The availability of good, package solutions in hardware and software for applications that in the past would have required extensive custom development work, *and*
- . Economic forces in the market place that favor consumers with unusual displays of creative competition on the part of vendors. ←

These technology factors have long-term implications with regard to the level of management control required, system architectures, applications, organization structures, cost efficiencies, and operating effectiveness. Highlights of our management conclusions include:

(1) Control

Direct control over low cost computing systems most appropriately belongs to the managers who are using them. There is minimal need for central control. There is, however, a strong need for central planning. To support central planning, information on where and how and to what extent users are acquiring information processing resources is essential.

(2) Micro/Mini/Mainframe Architectures

There is no single solution to the question of how micros, minis and mainframes should interact. The strongest factor to consider in relation to this management issue is the market. Vendors have identified it as in their interest to build compatible families of systems whose interoperability is guaranteed and transparent to the user community. It then becomes necessary for information processing professionals to

develop skills in evaluating proposed architectures and to adopt the role of systems engineer consultant to the user community.

(3) Effective Application Areas

The predominant categories of application areas for new technology include spreadsheet analysis, data management, communications, word processing and graphics. Like the issue of architectures, the issue of applications has no single solution. The availability of these automated capabilities in small, inexpensive, easy-to-use packages is a challenge to functional managers. They need to reexamine how they do business in the light of technological advance. It becomes their critical responsibility to identify specific applications and to make sure they are pursued.

(4) Pace

Ordinarily, the pace of acquisition and installation of applications should be dictated by the functional management group. These are the individuals who know the skills and needs of the user community and who, therefore, can best predict when applications will be successful. However, in seeming contradiction to the high volume of sales, the pace of applications is slower than it should be. There are productivity benefits to be realized from technology. They can only be realized if functional managers move from interested acquiescence to active proponenty. Senior level education may encourage this shift and enhance the pace of improvement.

(5) Roles and Responsibilities

Two significant new roles have already been discussed. Information processing professionals need to become systems engineers and consultants to the user community; functional managers need to pick up the roles of systems analysis and operations management. Another realignment can be anticipated within the information processing community. The distinction among skills and organization structures needed to manage the merging technologies of data processing office automation and telecommunications is blurring. The management structure for these technologies should be coordinated and integrated with functional management.

(6) Support Structures

Information processing professionals need to leverage their skills and experience by building new structures to support users in assuming their new responsibilities. The Department should consider establishing low cost computing consulting groups to assume responsibility for selected support activities from among the following:

ARTHUR YOUNG

- . Monitoring Technology Trends
- . Developing Low Cost Computer System Expertise in Selected Systems
- . Disseminating Current Technology Information
- . Assisting Users in System Selection
- . Trouble-Shooting During Operations & Maintenance
- . Evaluating Hardware
- . Evaluating Software Packages
- . Negotiating Volume Procurements
- . Designing/Delivering Training
- . Establishing and Operating Computer Stores
- . Building Compatible Micro/Mini/Maxi Architecture
- . Establishing a Central Demo Room
- . Offering Standard Application Systems
- . Establishing a Full-Scale Information Center.

Arthur Young & Company has appreciated the opportunity to work with the Department of Defense on this analysis of the technology trends in low cost computing and its implications for DoD. We look forward to the performance of future tasks in this exciting technology area.

Very truly yours,

ARTHUR YOUNG & COMPANY

By:



Henry J. Steininger
Partner

TABLE OF CONTENTS

	<u>PAGE</u>
I. INTRODUCTION	I-1
II. TECHNOLOGY TRENDS	II-1
III. POTENTIAL APPLICATIONS OF MICROCOMPUTER SYSTEMS	III-1
IV. MANAGEMENT IMPLICATIONS	IV-1

I. INTRODUCTION

I. INTRODUCTION

Many years after the introduction of large-scale integrated microprocessor chips, the impact of this technology break-through continues to reverberate through the market place. Triggered by technological advances, the interaction of technology, market forces, and management remains dynamic. Technology continues to be the source of management's hope for enormous improvements in productivity and overall effectiveness of operations. Yet it is also the source of management's greatest current challenge: determining how to adapt a work force and management structure designed for an earlier era to meet the needs of the new information technology era.

The purpose of this report is to present highlights of the most recent and important trends in information processing technology, and to assess their implications for management. The report is presented in four chapters. Chapter I provides an introduction and background for the project conducted by Arthur Young & Company for the Directorate of Information Resources Management Systems (DIRMS), Office of the Assistant Secretary of Defense (Comptroller). Chapter II focuses on technology trends. Chapter III discusses typical configurations of low cost information processing technology and their applications. Chapter IV contains our analysis of management implications for DoD.

This chapter provides a brief discussion of the background for the project, and a summary of the management issues that initiated this study.

1. BACKGROUND FOR THE PROJECT

The Directorate for Information Resources Management Systems (DIRMS) in the Office of the Assistant Secretary of Defense (Comptroller) has concentrated, over the past year, on analyzing technology advances and resulting management needs in the Department of Defense. DIRMS contracted with Arthur Young & Company to explore the potential impact of low cost computing technology on DoD and to assist in the development of a management strategy designed to take advantage of the new technology.

This project has been conducted in three phases. During the first phase, Arthur Young & Company examined technology developments and trends and assessed their implications for DoD. A preliminary series of management issues and concerns were identified. The second phase encompassed an analysis of private industry approaches to resolving the management issues identified, and an assessment of current strategies in the military services. This report is the final product of the second phase, an update to the first phase analysis of technology and management implications. In the third phase of the project, Arthur Young will work with DIRMS to develop a comprehensive approach for low cost computing, addressing policy and program initiatives for DoD.

2. SUMMARY OF MANAGEMENT ISSUES LEADING TO THE STUDY

Our earlier analysis of low cost computing technology trends and implications for DoD identified six key management issues. The issues result from the need to revitalize the existing information processing management role, the technical support environment, the organizational structure, and the adequacy of technical personnel qualifications to provide effective guidance and support for the widespread decentralized acquisition and use of systems by non-information processing professionals. Specifically, the issues of greatest concern for DoD senior management are:

- . Determination of the most effective level and means of achieving control over all aspects of microcomputer acquisition and use
- . Clarification of the technical and operational roles of microcomputers in relation to mainframes and minicomputers
- . Identification of the most appropriate application areas for microcomputers and the sequence for phasing the new technology into these areas
- . Determination of the pace for introduction and integration of low cost technology which will best suit the needs, capabilities and desires of DoD users and ADP professionals
- . Clarification of the roles and responsibilities assigned to ADP professionals and to end-users to ensure effective management of the new technologies
- . Identification of the most effective strategies and support structures for operating and maintaining low cost computing systems.

These issues, discussed briefly in the paragraphs that follow, have guided our current assessment of technology impacts and implications.

(1) Control of Acquisition and Use

The issue of control begins with the fundamental question of whether control over the acquisition and use of microcomputer systems is desirable, or whether it will serve only to obstruct the initiative of managers to find innovative, cost-effective applications for the new technology. If control is desirable, the most appropriate level for control needs to be identified.

To date, DoD has proceeded without formal centralized control over low cost computers. This policy was adopted to encourage experimentation, in order both to clarify the real

potential of microcomputers and to highlight potential pitfalls.

The management issue to be resolved is: How much control is needed, where and when it is needed, and through what means it can be most effectively applied?

(2) The Role of Microcomputers in Relation to Mainframes and Minicomputers

Microcomputers bring many of the management issues associated with distributed processing and minicomputers into consideration. The new capabilities and end-user orientation of the microcomputers make the selection and design of effective system architectures far more complex than it has ever been before.

The process of identifying which functions are most appropriately handled on a mainframe, a minicomputer or a microcomputer is complex. The options are diverse. Microcomputers can be used as stand-alone processors for applications with limited input/output device requirements and limited volume processing needs. They can be used as remote terminals in a dial-up mode with a mainframe to provide decentralized access to centralized systems. Microcomputers can be used in small clusters supported by a mainframe, or in super clusters where portions of the processing burden are down-loaded to remote processors connected to the mainframe. The most intricate system architecture option using microcomputers is the hierarchical network. In this architecture, super clusters are configured within higher level super clusters, which are connected, in turn, to the host mainframe.

The management issue to be resolved is: How should effective architectures be built and what are the implications for the organizational structure and skills of the information processing community?

(3) Microcomputer Application Areas and Sequence for Introduction

The application areas where microcomputers can be used in DoD are numerous. They include enhancement of traditional data or word processing functions, and development of new applications to support individuals directly in management or decision making activities. Some examples of these applications include the following:

- . Standard business applications, such as basic accounting, data acquisition, inventory reporting and control and personnel management

- Individual support applications, such as electronic mail, automated calendars, project management, computer-aided design, decision support systems, graphics, data base access/retrieval, operations research modeling and training
- Office automation applications, such as word processing, electronic filing, electronic mail and combined word/data processing.

The management issue to be resolved is: How can the most effective application areas be identified and what are the implications for the functional management community?

(4) Pace for Introduction and Integration

A key concern for DoD management is the pace at which low cost systems are introduced. A rapid pace, involving a large number of applications over a broad range of user groups, may cause failures, widespread disillusionment, and implementation of incompatible systems. On the other hand, an extremely slow pace will cause dissatisfaction among users who are eager to install the systems immediately, and a delay in achieving higher degrees of cost-effectiveness.

The management issue to be resolved is: What pace will best suit the needs, desires and capabilities of potential user groups?

(5) Roles and Responsibilities of Users, ADP, and Word Processing Professionals

Perhaps the most demanding management issue presented by microcomputers is the development of new roles and responsibilities. The traditional division of duties will continue to change with the introduction of this new technology. Users will work more directly with computers. ADP professionals may find significant roles in decentralized support activities spread throughout the user community. The move toward integration of word/data processing and telecommunications, in advanced office automation applications, requires a new definition of roles of the personnel involved. There is a need initially to encourage and eventually to require the acquisition of appropriate microcomputer technical expertise among users, ADP and word processing professionals.

There is also a critical need to identify changing organizational structure requirements. The definition and assignment of responsibilities may have significant impacts on organization structures, job descriptions, hiring goals and training needs for technical and user personnel.

The management issue to be resolved is: How should responsibilities be reassigned and how can DoD effectively achieve education and training goals?

(6) Support Structures

The installation of a significant number of microcomputer systems raises several important management issues for DoD in the area of support structures.

Currently, low cost computers are generally being acquired individually or in small numbers. If DoD continues this process, the department faces the potential problem of acquiring a large number of incompatible systems - causing interfacing problems and increasing the cost of training. At issue is the question of whether a central acquisition support structure could acquire these units at volume discounts, while achieving increased compatibility. However, a concern is raised that this support structure may slow down the acquisition process and possibly lock DoD into older technology.

The support function also extends to the availability of software packages which are being purchased individually in increasing numbers. An issue arises concerning whether DoD should enter into multi-site package arrangements or whether it should develop and distribute its own software packages.

Microcomputers are bringing to the marketplace new maintenance techniques and practices. These include remote diagnostics and the use of central "repair shops" where microcomputers are dropped off for maintenance like any small appliance. The most cost-effective approaches for maintaining and operating large quantities of microcomputers have yet to be identified. They may include development of technical capabilities within DoD. Contracting for service on-site may be a possibility if systems vendors, offering maintenance for microcomputers as a class of systems, will agree to perform the service for high volume purchasers.

The management issue to be resolved is: How can the systems be acquired, maintained and operated most effectively?

These management issues have guided our analysis of strategies employed by private industry and by the military services. They have strongly influenced the direction of our study of technology trends and implications. In the final chapter of this report, we present our analysis of key findings and a reevaluation of management issues.

II. TECHNOLOGY TRENDS

II. TECHNOLOGY TRENDS

This chapter presents our analysis of microcomputer technology trends in terms of hardware, software, and communications. In addition, the overall trends and market dynamics of these microcomputer system components are summarized for DoD consideration in the development of its overall management strategy.

To facilitate DoD review of the resulting range of findings and conclusions, this chapter is organized into four sections. The first section presents an overview of technology trends and market dynamics which have provided the basis for definition of the management implications presented in Chapter IV of this report. The remaining three sections of this report discuss the specific trends in microcomputer hardware, software and communications respectively. Each of these component technology trend discussions presents generalized definitions of topic areas, as appropriate; overall conclusions drawn with regard to trends in the specific system component area under discussion; and captioned discussions of notable areas where trends are occurring.

1. OVERALL FINDINGS AND CONCLUSIONS

The conclusions drawn from an analysis of microcomputer technology trends have two focuses: the current trends observed in hardware, software and communications technology development; and the dynamics in the microcomputer market place which will dictate continued trends in development/expansion of certain aspects of the technology and increased microcomputer application in organizations such as DoD.

The overall conclusions, drawn from our analysis of the specific technology trends discussed in Sections 2, 3, and 4 of this chapter, include the following:

- . The design and packaging of low cost microprocessor computers will continue to be aimed at the end-user having little or no ADP experience
- . Emphasis in low cost computing systems has been shifting and will continue to shift from hardware characteristics to software features, usability and friendliness
- . Price/performance ratios will continue to improve
- . Low cost computer capabilities, in terms of capacity and power, will continue to increase
- . Trend towards communication interfacing between processors will increase
- . Families of software packages, providing integrated capabilities (many functions in one package) to the end-

user, will be increasingly available

- . Trend towards multi-functional/multi-tasking systems will increase.

These trends have created a market environment which can be characterized as follows:

- . Increasing recognition of software as the key variable in choosing the system
- . Large volumes of hardware sales which create enormous software profit potentials
- . Increased segmentation and maturing of microcomputer markets which distinguish usage among home, professional workstation for larger organizations, and portable computers
- . Maturing user markets which will drive the software market in terms of applications and eventually hardware capacities and features
- . Integration of microcomputers into the overall information processing resources framework (office automation/data processing/telecommunications) with subsequent management strategy and policy-related implications.

These trends and market factors indicate that there is a strong potential for DoD to realize significant benefits from well planned and managed microcomputer use. These benefits include:

- . More effective operation through timely decision support, based on the broader automated information bases available to end users
- . More efficient use of secretarial, professional, and managerial resources, particularly through the reduction of redundant processing, faster information retrieval and automated analytical tools
- . More cost-effective computer support due to:
 - reduced requirements for special environment
 - reduced cost of the technology itself, with the capability to use an extensive range of packaged software to eliminate or minimize the need for custom applications development
 - increased processing speed over obsolete mainframe or early microcomputer and minicomputer systems

- increased user friendliness and reduced skill requirements for system support and development as well as operations, maintenance and ongoing training support for new users.

These summary preliminary findings resulted from our analysis of the hardware, software, and communication components of the microcomputer technology. The following sections present our analysis of the specific microcomputer technology trends in terms of hardware, software, and communications.

2. HARDWARE TRENDS

The purpose of this section is to present our findings and conclusions related to the hardware component of the microcomputer technology trend.

Microprocessor hardware consists of:

- Central Processing Unit - which is comprised of a large-scale integrated microprocessor (computer on a chip) which performs all arithmetic/logic functions
- Memory - which consists of random access chips (RAM) in various sizes. The memory stores the software which operates the system (reading and executing instructions and outputting results) and applications software which contains instructions for processing transactions.
- Storage - which can consist of a variety of magnetic media (such as disk or tape). The storage component holds all data files until they are called upon for processing and can record transaction outputs (such as file updates)
- Display Devices - which display on some type of monitor data inputs and outputs as well as file contents and interim processing commands as required of the operator.
- Input Devices - which provide a mechanism for data to be input to the computer for storage and/or manipulation; and for the user to enter processing commands.
- Output Devices - which provide a mechanism for the system user to output the results of application processing, files or programs onto another magnetic storage or print device.

Overall conclusions with regard to hardware trends are presented below. Trends with regard to each of the specific components of microcomputer hardware are then discussed in the subsections which follow.

From analysis of the hardware components, the following

overall conclusions can be drawn:

- . 16 Bit and 32 Bit microcomputers provide the processing power for substantial multi-user, multi application support, or very high performance single user work stations. This provides opportunities for:
 - cost-effective downsizing of many administrative applications from mini-computers and mainframes
 - automating local applications, particularly professional and management decision-support applications, which were either low priority or not cost-effective for large system implementation.
- . Lower memory costs provide a capability to configure microcomputers with powerful memory capabilities which support multi-functions via integrated software (many applications in one package), data base management and increased user friendliness by minimizing the human instruction interfaces required for program operation.
- . Storage capabilities have increased substantially with the introduction of the hard disk, which provides storage for 5 or more megabytes (5 million characters) of information in a fixed location. However, portability is a problem due to lack of format standards among disks of various manufacturers. Laser disks will provide even more dramatic storage capability when updating problems are resolved.
- . Color displays and projection displays are excellent media for output of management decision support information, particularly graphic and video applications.
- . Keyboard technology will improve in terms of ergonomic design and portability to support the professional user.
- . Optical character readers for typed text are improving in quality and costs are being reduced. Thus, the use of automatic typewriters as first draft devices may become a viable alternative to acquisition of additional data entry workstations.
- . Reliable output devices for graphics and letter quality print are readily available. Laser printers for both monochrome (single color) and color output have the potential for competing with other print output devices for large microcomputer systems, as soon as the laser printers are perfected mechanically and prices are reduced.

Trends in terms of specific hardware components are discussed in the following sub-sections.

(1) Central Processing Unit

Central processing unit trends were observed in terms of the computer architecture itself and the application of various size microcomputers in the business environment. These observations are discussed below.

Architecture

The architecture of a micro-processor is usually defined in terms of four items:

- o Register size - currently 8, 16 or 32 bits.

(The register is a memory device capable of containing one or more computer bits or words (combinations of bits).)

- o Address bus width - currently 16, 20 or 32 bits.

(The address is a computer system location that can be referred to in a program. The bus width is the size of the memory location capable of holding addresses for locations of any physical item in a computer system.)

- o Data bus width - currently 8 or 16 bits (32 bits is under development).

(The data bus width is the size of the memory location capable of transferring data from a storage device into computer memory for processing.)

o Size of instruction set.

(The instruction is a statement to the computer that specifies an operation to be performed by the system and the value or location of all operands. An instruction is usually made up of an operation code and one or more operands. The larger the size of the instruction set accommodated, the greater the processing speed and fewer instructions required.)

A fifth consideration is clock speed. This is more of an attribute than an architectural element since a single processor may be set to run at various speeds. Speeds generally range from 1 mhz (million cycles per second) on such low-end 8 bit processors as the 6502 (Apple, Atari, PET), to 10 mhz or better on the newer 16 and 32 bit processors such as the Motorola MC 68000 (Apple Lisa, Fortune, Altos).

When we refer to a machine as being an 8, 16 or 32 bit unit, we are generally referring to the register size of the processor. When the first personal computers came on the market, they used 8 bit registers with 8 bit data busses and a double register (16 bits) for addressing. Thus they could store, retrieve and process data 8 bits (one byte) at a time and could address 64k bytes(b) of memory. Popular examples of this architecture are the 6502 and Zilog's Z80.

One of the first improvements on this was to extend addressing to 20 bits by adding another half byte. This was done by adding a "black box" over and above the processor chip rather than by redesigning it. The Apple III is an example of this type of approach. This increases the address space from 64kb to 256kb.

A second improvement, also on the Apple III, was to widen the address bus to 16 bits (2 bytes) so that twice as much data could be stored or fetched in a single operation. However, since the processing registers were still only 8 bits wide, this was an intermediate development at best.

The next evolutionary step was development of processors with 16 bit registers. In order to overcome the 64k addressing limitation, these chips were designed with extended addressing registers using 20 bits or more. Although the registers were doubled in width, the data bus was kept at 8 bits, primarily for cost reasons. These chips also had more extensive instruction sets. For example, multiplication. In contrast, the 6502 has no multiply instruction; the programmer has to simulate one using other operations such as shifts and adds. As a result, programs written for these newer processors are more compact and run faster. Examples of 16 bit processors with 8 bit data busses are the 6809 and Intel's 8088 which is used in the IBM PC (Personal Computer).

The limitation of an 8 bit bus throttling a 16 bit chip was removed with the introduction of the Intel 8086. This is a true 16 x 16 chip with extended addressing. Meanwhile, however, Motorola came out with the 68000 chip. This went a step beyond by widening the data registers to 32 bits while holding the data bus to 16. It also supports one of the faster clocking rates ranging from 6 mhz up to 10mhz (experimental), and a very powerful instruction set. This chip has been used by Apple in its just announced Lisa, by Fortune, and by a number of other established micro-vendors.

A 32 x 32 bit micro-processor chip, the MC 68020, is rumored to be well along in development.

Role of 8 Bit and 16 Bit Microcomputers

While the new 32 bit microcomputer provides substantial capabilities for users with larger processing requirements, at this time, most major microcomputer vendors are marketing 16-bit processors. Larger hardware sales are providing the incentive for substantial commercial development of packaged software for 16-bit microcomputer use. It should be noted, however, that for existing users of 8 bit microcomputers, there are over 30,000 existing application packages. Development will probably continue to support these 8 bit systems for some time because of the extensive number of these microcomputers currently in operation.

Future Trends

The future will be dominated by the 16 and 32 bit CPU's. Transportability and eventually portability (self-contained power supply) will continue to improve for the applications requiring it. The size and weight will decrease slightly but increased capability may cause a general price increase in portable microcomputers in the future.

(2) Memory

Memory trends were observed in terms of architecture, decreasing cost, and ability to support more complex software. These observations are discussed below.

Architecture

Microcomputer memory is defined in terms of "chip" size. This ranges from 1K (1,000 bytes) to 256 k. A microcomputer with larger memory means there is the capability to place more instructions in memory. This makes it easier to use software because there is less of a requirement for human interventions in terms of instructions. Accordingly, programs execute faster. It also provides for more powerful graphics with higher resolution.

Decreasing Chip Cost

64k chips, which are the most common on personal computers, currently cost \$4 to \$7 for dynamic memory. The 256k chips, which will support substantial applications capability and speed, are predicted to cost only \$7 each by 1986.

Integrated Software

The low cost of dynamic memory chips has provided the opportunity for operating the integrated software (many applications in one) on microcomputers. Increased user friendliness due to simpler operating instructions is also attributed to the amount of stored instructions handled by the increased memory capacity.

(3) Storage

Storage trends were noted in the areas of disk drive architecture, continued differentiation in disk formats among vendors, and increased interest in reliable back-up media. These trends are further discussed below.

Disk Drive Architecture

The market today is geared toward 5 1/4" and 8" floppy and Winchester hard disk drives. In the near future, recording density increases of several orders of magnitude can be expected as plated thin film media and ceramic reading heads replace today's oxide technologies.

Costs of these disk units have dropped dramatically because of component price decreases. Physical size of the drive units is now being cut exactly in half, allowing two units to be mounted in existing cabinets. This latter trend is increasing the portability of microcomputers.

For applications requiring greater transportability, 3" floppy and Winchester disk technology is emerging. These micro floppy disks will contain close to 1 megabyte of usable data but will be more costly than the 5 1/4" devices. Industry experts predict that magneto - laser devices, now in laboratory testing, will eventually replace current disk storage technology. The best guess is that this is still years away.

Disk Format Standards

The lack of disk format standards will continue to be a problem for users. Numerous formats are possible in each disk size. Since vendors perceive a competitive advantage in maintaining proprietary formats, this unfortunate trend will probably continue. This makes program and information

transfer difficult when using disks of different manufacturers.

Archival Storage

Tape continues to be a reliable medium for serial back-up. Floppy diskettes arranged in a special cartridge stack also offer a cost effective back-up medium.

(4) Display Devices

Display devices provide a medium for representing data in visible form. Display trends were noted in the areas of single color versus color display applications, and management use of television and projection display. These are discussed below.

Display Technologies

Micro-computers can be configured with a variety of display technologies including storage display, composite versus RGB, raster scan, interlaced, non-interlaced, plasma, and LCD (liquid crystal display). Selection of a display type is typically based on required resolution, color, and the type of display supported by specific manufacturers' hardware.

Monochrome Versus Color Displays

The major choice for the user is typically whether a monochrome (single color) or color display is required.

The monochrome display provides an inexpensive, quality, low cost data display. For general purpose microcomputing functions such as word processing, records management, and electronic spreadsheets, this will remain the preferred display medium.

Color displays are popular for more sophisticated business uses such as graphics or data entry into displayed forms, although color is not being considered on many office systems such as the Apple LISA.

Use of Television Monitors

It is significant to note that since NTSE composite video displays may operate on the same type of signal as a TV, often with sound, some microcomputer may be linked to television monitors, (particularly projection televisions), for use in presentations, training, and actual working sessions.

(5) Input Devices

Trends in data input devices were noted in keyboard architecture, optical character reader improvements and non-

keyboard devices oriented toward streamlining the data entry and user command input processes. These observations are discussed below.

Keyboard Input

Input devices serve two primary functions: the actual input of data, and as a communications medium between the user and the system. Most data input is currently accomplished through keyboarding. The majority of current keyboards are based on the QWERTY format, with the special function keys varying widely in physical position from one manufacturer to the next. Users continue to dictate specialized keyboard design by cost and volume.

Cordless keyboards will be available by 1985 although strong user demand for these has not been evidenced.

Optical Character Readers

Optical character readers offer another data input method. At least one vendor markets a reader which is capable of reading eight type fonts in a price range under \$13,000 and at a speed of 25 seconds per page.

Other Input Devices

Other data input devices include: bar code readers, voice recognition (still limited), and such traditional devices as card readers. Special devices such as graphics tablets are also available.

The most significant and perhaps exciting advance is the means by which the user communicates commands to the system. On the first generation micros, the keyboard usually served the dual purpose of data and command input. This was sometimes supplemented with light pens, game paddles, and joysticks with varying degrees of success. We are now seeing such devices as touch sensitive screens (allowing the user to command the system by pointing) and most dramatically, the "mouse". This device, long recommended by ergonomic experts, is now becoming available as an add-on device to almost any micro, although software to use it will be a problem. The "mouse" is a significant feature on Apple's LISA. Essentially the "mouse" enables the user to "drive" around the screen, pointing at command ICONS with the same kind of hand/eye coordination one uses in driving a car. Early user reports indicate it is fast, effortless and quickly becomes automatic.

(6) Output

Trends in data output devices were noted in terms of improved printer quality and high speed output devices. These observations are discussed below.

Printers

Dot matrix printers are increasing in use because they provide low cost single or multi-color graphics capability. Plotters are increasingly used on small systems for multi-color support to graphics applications.

Letter quality printers for high quality print are an established technology. They are basically capable of slow (up to 55 characters per second) typewriter quality print most often used with word processors and professional work stations.

Laser printers are the newest development offering high quality, high speed print with forms overlay capability. Laser printing in both monochrome and color, once perfected and reduced in price, will be an alternative to currently used dot matrix, daisy wheel, and line printer types.

Alternative Output Technologies

Intelligent copiers (xerographic) and ink jet printers are also alternative technologies for high speed printed output.

(8) Maintenance Trends and Reliability

With a rapidly expanding microcomputer market, the hardware maintenance capabilities available become an important consideration. Observations regarding improved microcomputer service capabilities are discussed below .

Overall Trends

Microcomputer reliability continues to improve. Reductions in circuit size has resulted in smaller interconnect spaces for electronic signals to travel through (with fewer corresponding opportunities for problems), improved quality in manufacturing, and less environmental considerations in terms of temperature and humidity.

The maintenance trends have not changed significantly in the past eighteen months. Since many more microcomputers are in use, the maintenance turnaround (from about the same number of repair facilities) is somewhat slower today. It is anticipated that with more extensive dealer networking and service capability, repair servicing may improve for major vendors' standard microcomputer systems. Custom configured systems will still be dependent on the original vendor. This is an important issue in the acquisition process.

Service Organizations

Service organizations such as TRW and RCA provide on-site service to users nation-wide and will overcome many of the service problems that exist today.

3. SOFTWARE TRENDS

Software consists of the operating system and the applications software. The operating system manages the interaction of the central processing unit and memory, and controls the reading of instructions into the CPU, the execution of commands, and the output. The applications software contains the instructions for accomplishing processing transactions, or (as in the use of a data base management system) provides a framework for the organization of data against which processing commands are input and executed.

Software trends are discussed in the following subsections, first in terms of conclusions, then overall trends and specific trends in applications software, programming languages (which support applications software development), and operating systems.

Conclusions which can be derived regarding software trends include the following:

- . Operating system development for 8 bit CPU's continues to facilitate development of newer microcomputer applications on these older systems.
- . Availability of software packages lags hardware sales. Substantial software exists for 8 bit CPU's, while software development for 16 bit CPU's lags sales due to market demand and greater complexity for development. However, many popular packages, written in higher level languages, are being recompiled for use on 16 and 32 bit machines. The popularity of the IBM Personal Computer, a 16 bit micro, will substantially increase the availability of 16 bit-compatible software.
- . Existing 8 bit CPU's are not obsolete if they are adequately supporting the functions for which they were acquired, or can be upgraded with newer software still under development.
- . Some new operating systems for larger microcomputers support timesharing and multi-processing against integrated software packages (many applications in one package).
- . High level languages provide excellent, user friendly tools for software development in support of business or mathematical/statistical applications.
- . Professional software/hardware personnel are only required to support larger microcomputer-based systems which support multiple users and the more complex

operating systems.

(1) Overall Software Trends

The following three major software trends are being experienced by the microcomputer industry today:

- . Use of metaphors (familiar human-oriented symbols) to increase user friendliness versus increased functionality
- . Integration of communications software into the operating system (with eventual hardware integration)
- . Integration of application software - the development of application packages which provide many applications in one package.

Each of these software trends are discussed below.

Metaphor Approach to Software Development

The metaphor approach to software development features software design that provides familiar symbols to assist the user to understand the types of information processing capabilities available, and to execute commands. Visicorp's VISI ON is an example of this type of operating environment. With VISI ON, applications are displayed on a screen that corresponds to the desk of the user. Each application appears on the screen in a separate window. The user accesses one or more of them by moving a cursor controlled by a peripheral called a "mouse". The mouse is a small box located on the user's desk which controls a cursor on a display screen. The mouse cursor acts as if it were an extension of the user's arm. The user "drives" the mouse around their desk in conjunction with the movement of the cursor toward command icons on the display screen. When depressed, a button on the mouse executes the command at which the cursor was pointed.

The metaphor approach requires greater memory for execution and is not appropriate in such applications as word-processing from a secretarial perspective, since memory requirements would exclude use of more sophisticated editing features. This approach is being employed in systems oriented mostly toward professional users. For example, the Apple LISA has 1 million bytes of main memory. Its software required two thousand person years to develop. The result is a system that a first-time user can have up and running in twenty minutes.

Communications Software Integration

With anticipation of extensive communications requirements, the microcomputer industry is moving toward integration of communications software with operating systems. Therefore, communications will become a capability

of all microcomputers and not an option. Hardware integration of modems into microcomputer cabinets will follow communications software integration.

Applications Software Integration

The last trend, software integration, refers to software packages that combine several major functions. For example, Lotus 1-2-3 combines electronic spreadsheets, business graphics, and information management in one easy to use package. These integrated packages are typically lower in cost than the separate functional packages. Integrated packages allow the user to carry the same data through several applications. For example, in Lotus 1-2-3 the user can extract data from an information file, input it into an electronic spreadsheet, and then display analytical results in graphic form without having to input each application as a separate program. This capability substantially reduces the number of user instructions required to accomplish the end results.

Future Software Trends

In the future, larger memory at lower cost will continue to vastly simplify software use, particularly in application areas. As larger chunks of program and data are handled on-line and in memory, the complexity of operation will be decreased and thru-put speed will be increased. This is due to decreased human (manual) intervention and increased use of advanced hardware architecture.

Downsizing of large mainframe software to micro-computers will occur as hardware memory sizes increase. Downsizing will depend upon file size, program size and type (language), and hardware limitations. Many current file-extraction and analysis systems will be prime candidates for this downsizing in the near future.

Advanced 8 bit operating systems will be readily available by 1985. This will surely extend, via operating systems, the life of the many 8 bit microcomputers far into the future.

In the applications software area, the large number of packages available will decrease the involvement of data processing personnel for well-defined applications. Figure III-1 on the following page compares low cost computer development figures as compared to mini software development.

The selection of software applications will continue to be a difficult and confusing task given the vast array of available packages. Users will have to evaluate carefully applications packages for use in their specific application as well as to attempt to detect defects ('bugs') in candidate

Applications Software Development for Low Cost Computers Vs. Mini Computers (6,743 Firms)

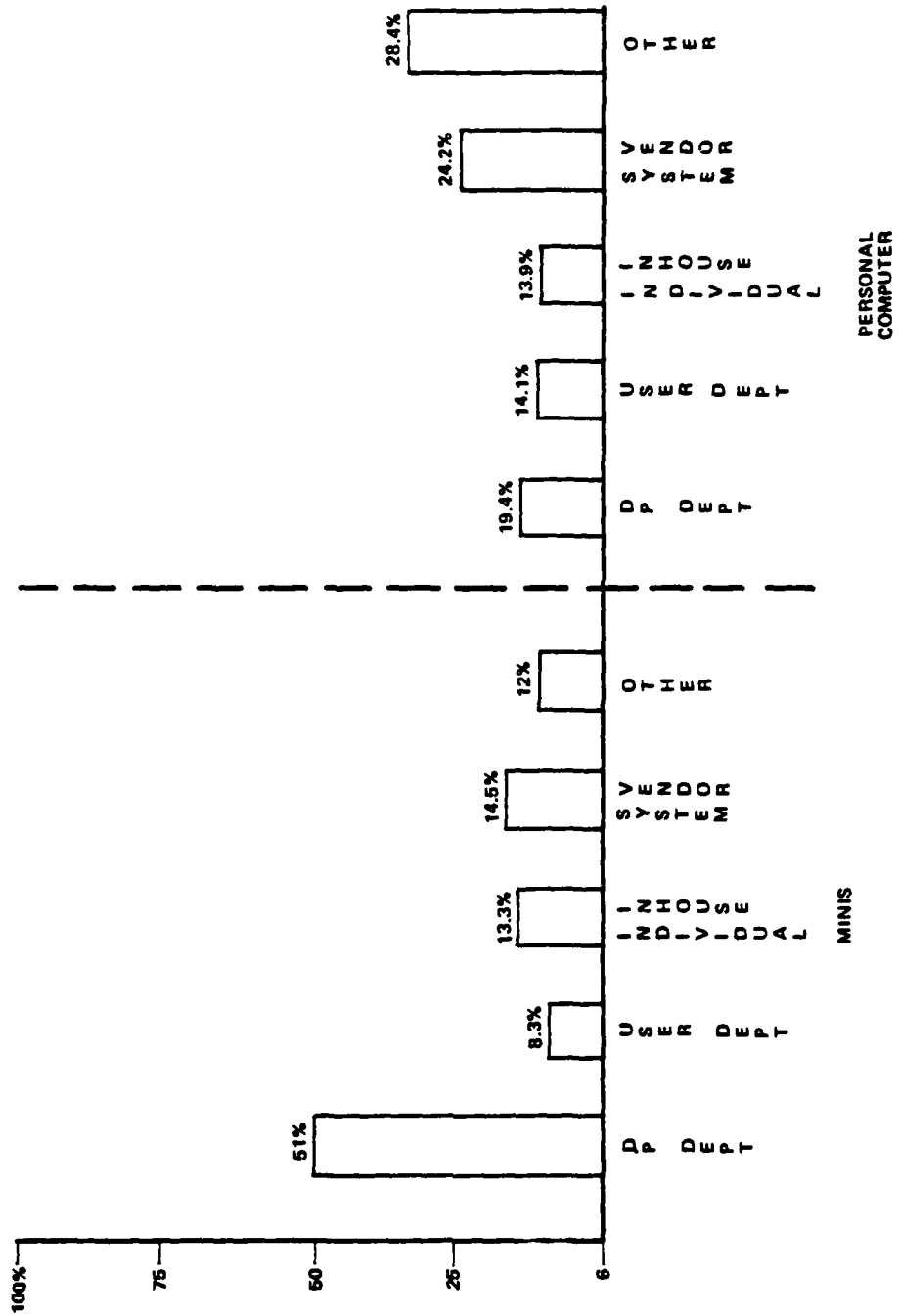

FIGURE III-1

SOURCE: COWEN/BYTE

systems.

(2) Application Software

As noted in the prior sub-section, industry watchers are beginning to see a divergence in software development objectives between ease of use on the one hand and increased functionality on the other. The first objective is geared toward the casual user who has neither the time to master, nor the need to have powerful complicated packages. For example, the management-level person who wishes to use a word processor to compose short inter-office memos does not need footnoting, subscripting, variable type fonts, automatic indexing, automatic hyphenation, etc. as might a typist. Conversely the clerk-typist would be frustrated by the lack of these features in a package geared toward the manager's needs.

It follows that ease of use and high functionality, while more or less mutually exclusive at the present, both have their place within an organization. Products such as Visicorp's VISI ON and Apple's LISA are targeted to the ease-of-use market segment while such powerful packages as Lotus 1-2-3 are designed for the experienced, demanding and frequent user.

One thing both of these approaches have in common is functional integration. This is the capability for the user to generate or work with data in one mode, (e.g., a spread sheet), and instantly move to another mode, (graphics or word processing perhaps), to continue processing the same data. Each of the software products mentioned above accomplishes the objective to a greater or lesser degree.

Over the next decade we will see this drive toward functional integration as being a major goal of the microcomputer industry.

The familiar areas, (word processing, data base management, spreadsheet processing, and graphics), remain the heart of the market. Some 150 new packages appear each month. These packages include totally new applications as well as improvements on such old standards as VISICALC, DBASE II, WORDSTAR, and CONDOR.

(3) Programming Languages

Today the predominant programming languages are: BASIC, FORTRAN and COBOL, with specialized languages such as ALGOL, PILOT and PASCAL in fairly common use. Each CPU family, such as 8080 or Z80, has its own assembly language which is used by owners of such systems, depending upon the expertise of the individuals involved. Languages such as C and ADA, will lead the future programming language utilization.

(4) Operating Systems

An operating system is the software that controls the movement of data from storage, through processing, and to output. CP/M, MP/M, MSDOS, and UNIX have become de-facto standards. This does not imply they are the best systems, only that they represent some of the best choices today. Many versions from many sources exist for these systems. Each has advantages of its own. In recent months, advanced 8 bit operating systems, (such as IDRIS, a UNIX-like operating system), have become available. This has greatly extended the life of the 8 bit microprocessor because of the types of software accommodated and improved operating performance.

Selection of an operating system will be a critical consideration for DOD users since it determines how the system can be used. Questions to be considered include:

- . Program requirements for the next two years.
- . Required operating system and computer for major application programs.
- . Need for single- or multi-user system within one year.
- . Need for microcomputer software compatibility with a larger computer.

The answers to these four questions can determine the types of operating systems required.

A major trend in operating systems will be the collapsing of functions such as graphics, data communications, and networking into the system.

4. TELECOMMUNICATIONS

Telecommunications refers to the capability of one microcomputer to communicate with another micro, mini or mainframe computer, and specialized devices such as xerographic copiers and file server-type shared storage devices. Telecommunications capability requires both appropriate hardware interfaces and software. As noted in the previous software discussion, there is a trend toward integration of telecommunications capability into microcomputer systems in lieu of it being a separate option.

The design of a telecommunications network for microcomputers is a complex initiative which must be tailored to the unique organizational environment which the system supports.

Obvious conclusions to be drawn regarding communications trends for microcomputers are:

- . Communications protocol standards must be adopted to

ensure system integration

- . Local area networks provide substantial capabilities for resource sharing and communications, as well as serving as nodes in larger networks.

In the sub-sections which follow, some of the major trends and issues involving microcomputer networking are discussed.

(1) Communications Trends

Communications trends were noted in terms of increasing data transfer speed capabilities, network use and design, and standards development. These observations are discussed below.

Communications Speed

Asynchronous communications at speeds from 300 to 1200 BPS (bits per second) are found in wide-spread use today. Some major manufacturers such as IBM, WANG, and Raytheon can support speeds up to 9600 BPS.

Local Area Networks

Local area networks (LAN's) are in use throughout the U.S. today. Exhibit II-2 on the following page depicts these trends. While such software is traditionally thought of as communications, in fact it consists of data base management and file server (a larger storage device supporting several microcomputers in a shared mode) software which is truly a form of applications software. Such firms as NESTAR, mixing APPLE and IBM PC units on a single large net, allows high speed information transfer within the net and onboard data communications to other LAN's or computers via gateways.

Local Area Network Standards

The IEEE 802 Local Area Network Committee has come up with user standards for networks. The draft, P802.3, is being sent to the 500 member technical committee for approval.

Seven layers of standards are proposed:

- . Application layer -- end-user applications which employ lower-level communications facilities (e.g., Advanced VisiCalc, electronic mail)
- . Presentation layer -- file conversion, translation of character sets, byte sizes, from one format to another, in short, mapping machine-dependent data formats into a virtual representation and back into another format

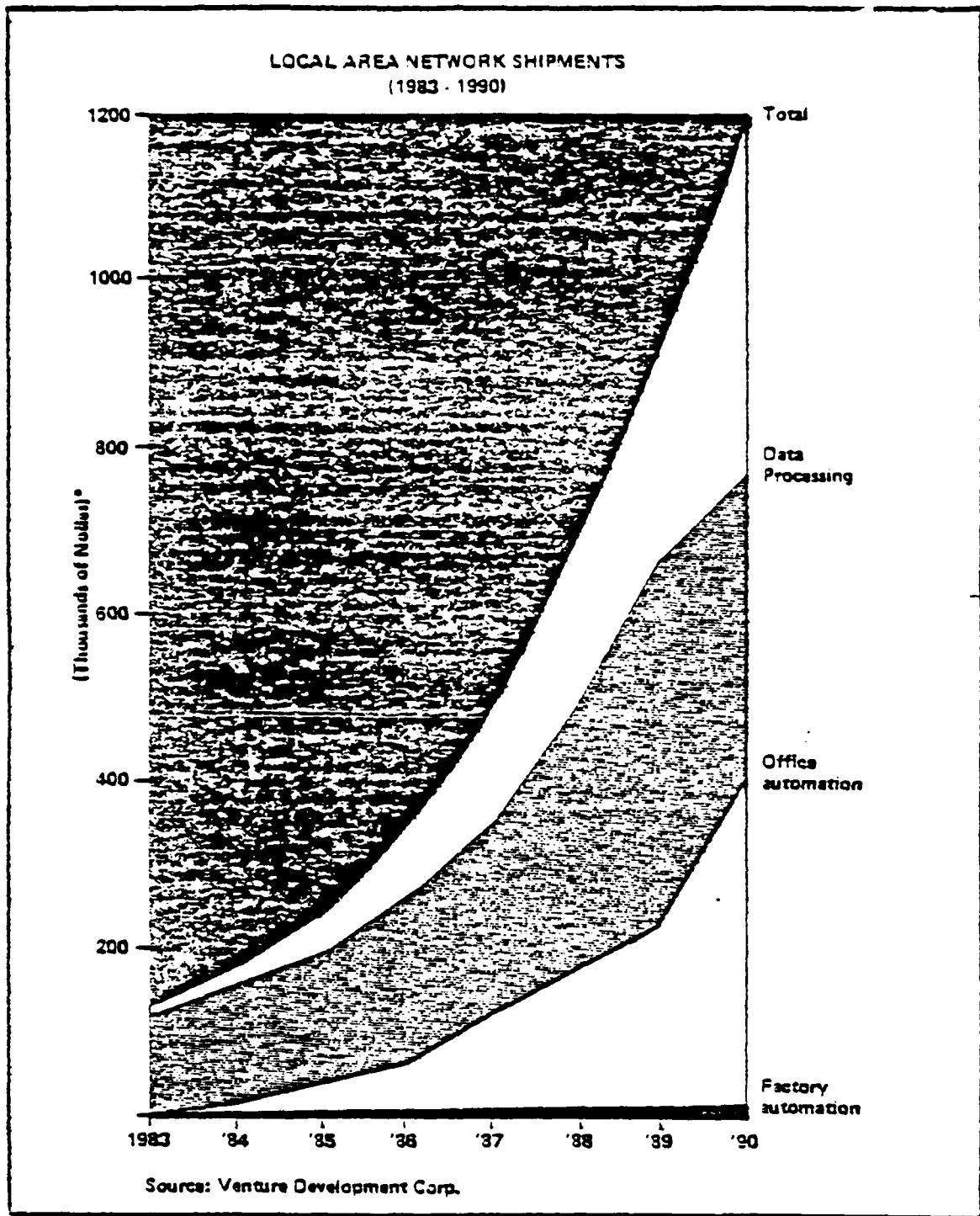

* Node Represents a Cluster of Eight Terminals or Similar Devices.

- . Session layer -- procedures for recovering if a session (connection) fails at lower levels
- . Transport layer -- byte stream management (includes error detection and correction, etc.) to ensure reliable data stream
- . Network layer -- routing conventions for datagrams (packets); addresses
- . Data link -- access methods such as token passing, and carrier-sense multiple access with collision detection, as well as information packet framing conventions; length of packets, format of headers and trailers (Note: Typically data is transmitted over networks in packets as opposed to a steady stream.)
- . Physical layer -- transmission medium: voltages; broadband vs. baseband.

According to the Rosen Electronics Letter, (January 6, 1983), 'the choice of the two lowest levels should depend on criteria such as the system size, intensity of use, delay-tolerance and financial position of the purchaser. Because networks can be linked together -- easily if the network layers are compatible -- a single user may well operate several different kinds of networks for different segments of his business, and link them all together with another network or perhaps a PBX (telephone switching network). The choice of the rest of the levels depends on whom you want to talk with. There are few clearly established standards. Even those are more guidelines or prototypes than concrete implementations. Most "network" systems address only some of these layers, leaving selection of the rest up to the user or system integrator. In particular, the software-intensive top layers are the most complex, the most confusing, and the least standardized.'

III. POTENTIAL APPLICATIONS OF MICROCOMPUTER SYSTEMS

III. POTENTIAL APPLICATIONS OF MICROCOMPUTER SYSTEMS

The applications to which microcomputers can be applied in DoD are numerous. They include enhancement of traditional data or word processing functions and development of new applications to support individuals directly in management or decision making activities. Some examples of these applications include the following:

- General applications, such as basic accounting, data acquisition, information storage and retrieval, inventory reporting and control, and personnel management
- Individual support applications, such as automated calendars, project management, computer-aided design, decision support systems, graphics, operations research modeling and training
- Office automation applications, such as word processing, electronic filing, electronic mail and combined word/data processing
- Dedicated process control, such as energy management, weapons control and manufacturing process control.

In the preceding chapter, software trends in packaged applications development as well as tools for custom software development were discussed. It is important to note that quite often the specialized requirements of the user group impose constraints that quickly limit consideration of microcomputer systems to a few available applications. Accordingly in the sections which follow, some examples of the potential uses which DOD may have for the types of applications discussed above are presented. This chapter concludes with a brief discussion of the types of microcomputer hardware configurations which could be considered by DOD to promote information exchange and resource sharing among stand-alone microcomputer systems.

1. GENERAL APPLICATIONS

General applications processing refers to the performance of local data processing functions using low cost computing hardware and software. Typical applications are basic accounting, data acquisition, information storage and retrieval, inventory control/reporting, and personnel management. Many current applications in this area were performed previously on central data processing or mainframe equipment, or were performed manually. There is an increasing use of low cost computing by organizations who in the past found data processing a costly alternative. Today, many applications are now cost-effective due to the decreasing cost of both hardware and software packages.

A brief review of current and potential DoD applications of low cost computing in the area of general applications includes:

- Budgeting - this application (usually built upon an electronic spreadsheet framework) refers to support in budget preparation, modification, and reporting. The DoD command budget preparation process is very complex requiring the aggregation of large amounts of data, many interactions, and requirements for fast turnaround on last minute adjustments. Further, the budget submissions are required to be aggregated at various levels of detail. Both field and headquarters operations may find useful the capability to easily format and input budget information, make revisions and produce reports for inclusion in higher level budget plans. Specific applications include:
 - Preparation of annual budget plans by individual units or program offices and integration of these budgets for inclusion in the annual budget report.
 - Ask "what if" questions in the preparation and adjustment to budget submissions.
 - Budget planning and analysis to determine the most cost-effective projected use of requested funds in a number of competing areas.
 - Tracking of actual expenditures against the budget.

- Inventory Control/Reporting - DoD maintains the largest and most diverse repository of hardware, materials, and supplies in the world, both in the United States and internationally. Microcomputers can be used in small to medium sized operations (i.e., as high as 10,000 separate line items) to record stock levels on a continuous or periodic basis and to perform inventory analyses and reporting. This could include:
 - inventory maintenance
 - monitoring maintenance cycles
 - computing optimum inventory levels
 - reorder frequencies and stock-out policies.

As microcomputer storage capabilities continue to increase, even larger inventory applications will become feasible.

- Information Storage and Retrieval - DoD and the Armed Services maintain extensive information files both in the field and at various headquarter facilities. These include

personnel files, equipment and property files, publication lists, training course lists, etc. Using microcomputer data base management capabilities, either in a stand-alone configuration or linked to one or more host computers with access to additional files, file management and information storage and retrieval can be made more efficient.

- Accounting and Financial Recordkeeping - General accounting and financial recordkeeping functions are performed at multiple levels in DoD and in the Armed Services. Accounts receivable, accounts payable, payroll, cash disbursements, purchases, and other general accounting activities are recorded and aggregated to maintain overall DoD financial accounting requirements.
- Data Acquisition - Data is captured and recorded in many dispersed locations by DoD field operations, headquarters, and the Pentagon. Data can be for local use or may be integrated with data from other sources and accumulated in a central file. Microcomputers are effective data recording, editing and transmitting tools and can be easily transported to data capture sites for ease of input and interactive edit capability.

2. INDIVIDUAL SUPPORT APPLICATIONS

The area of individual support applications is probably the newest of the low cost computing applications. Low cost computing usage in this area is currently increasing due to user demand and greater availability of analytical and industry specific software. Individual support tools are oriented toward the manipulation of quantitative entities (numerics and graphics) for analytical purposes and to aid the user in decision-making. Typical applications include project or program management, financial analysis and modeling, operations research modeling, training and decisions support. Applications in this area are often used to determine cost-effective choices among alternatives or to determine consequences of different input parameters or problem structures (i.e., "What if" questions).

Microcomputers are effectively used for decision support functions due to their interactive capabilities, their ability to store and process large amounts of data quickly, and their low operating cost and ready accessibility. Software in this area can be purchased from established software vendors and from individual users listed in software directories. The user can also develop customized programs using a language compiler such as BASIC, FORTRAN, COBOL, or PASCAL to meet specific requirements. The range of available software and user applications includes packages such as VISICALC, used for financial analysis and modeling; computer graphics packages, used for graphic presentations of numeric data or physical entities; industry specific packages, used to model processes and activities in specific business or functional areas; and decision support packages, used to aid the

user in selecting among alternatives based upon performance against predefined criteria. Packages generally provide good performance characteristics and, depending on the user's experience, are easy to use.

Current and potential DoD applications of low cost computing in the area of individual support applications include:

- Logistics Planning and Support - This application refers to support in the area of distribution; transportation; movement of troops, supplies, equipment and vehicles; and storage of goods and materials. Logistic planning is a critical function in DoD and is essential to effective initial engagement and sustained engagement with the enemy. Microcomputers can provide support in planning, designing, improving and reporting logistics activities.
- Project and Program Management- DoD participates in and directs many development and implementation projects and programs of significant size and complexity such as the Trident and Polaris programs. Field units and individual headquarters program offices also manage projects of smaller scale which, however, may have a number of tasks and tight completion deadlines. Typical applications for project management using microcomputers include project scheduling (CPM and PERT), project tracking, personnel/resource allocation, cost estimation/control, job scheduling, automated calendars and resource information retrieval.
- Financial Analysis and Modeling - This application area may include the use of electronic spreadsheet programs which support "What if" types of analyses. Any level of organization within DoD can use financial modeling and cost-effectiveness analysis to aid in making decisions among various alternatives or to determine the consequences of external factors on one or more alternatives.
- Training - DoD operates one of the largest training programs worldwide. Applications in this area include tracking training needs for specific personnel, scheduling training courses, maintaining rosters of trainees and instructors, providing training via computer instruction, and maintaining individual and cumulative scores and performance measures.
- Computational Support and Simulation - Many programs can be developed by individual users to support their work function and needs. The range of potential individualized applications is as varied as the users needs but are typically constructed around basic software tools such as electronic spreadsheets, statistical analysis packages, scheduling packages and data base management systems. These may include applications such as:

- Simulation of operations with different configurations of unit capabilities.
- Aircraft, vehicle, and ship availability. Determining the availability of a simulated operation that is conducting quick turnaround contingency operations from a forward location.
- Fixed angle bombing. Calculating necessary information for timings and headings for fixed angle bomb runs.
- Takeoff data. Inputting data for fuel loading, temperature, pressure altitude, and runway length. Determine takeoff data such as power settings, takeoff roll, takeoff speed, etc.
- Performing capacity planning to determine the number of vehicles required to provide sufficient capacity for a troop exercise.
- Performing a queueing simulation to determine the number of maintenance unit personnel required to perform preventive maintenance or repair work for a company motor pool.
- Preparing maintenance schedules for ship repair and maintenance, inventory reports of parts required for scheduled maintenance functions, and inspection crew schedules for review of fleet readiness status.
- Preparing performance failure trend analysis for vehicles, aircraft and ships and individual parts to determine the most effective preventive maintenance cycle.

• Scientific and Engineering Computational Support - The DoD, with its high technology weaponry and sophisticated systems, makes use of large numbers of engineers and scientists in the design and enhancement to these systems. There is currently a shortage, predicted to be even a worse shortage in the future, of engineers critical to this function. Low cost computing technology can be applied to make more effective use of valuable talent. The technology can replace programmable calculators, timesharing on large computers, slide rules, hand computation, etc., freeing the few available engineers to concentrate on more creative engineering activities. Software for these uses is generally written directly by the user in FORTRAN or BASIC. Examples of applications include conventional weapons design, weather forecasting, chemical analysis and medical/biological research.

- . Computer Aided Design - Electronic circuit design programs that calculate the parameters of circuit components based on performance requirements are available to run in BASIC. These programs could be used by engineers in R&D Labs such as NRL, Harry Diamond Labs, NSWC, etc. A single low cost system could be dedicated for use by one engineer or a team of engineers.
- . Graphics - DoD may use microcomputer graphics for presentations, mapping applications, teaching aids, financial planning and analysis, and simulation. The Defense Mapping Agency (DMA) already is making extensive use of microcomputers. DMA's objective to digitize the world in order to produce any type of mapping or guidance control information off of a readily available data base can be assisted greatly by the use of microprocessing.

3. OFFICE AUTOMATION

Another major category of usage includes those administrative support functions generally known as word processing or office automation. While dedicated microprocessor-based "word processing machines" have been marketed since the mid-1970s, the trend is moving towards the use of office automation packages on more general-purpose low cost hardware configurations. A concurrent trend has been the expansion of functions to include electronic filing, electronic mail, and automated calendars. Thus, office automation is shifting away from automated typing support (completely removed from the typical "data processing" organization) to an integrated and interdependent information management view which requires the cooperation of both word processing and data processing personnel. For example, electronic filing is now being introduced into the office automation area, due in part to advances in low cost computing hardware and software, and in part to the realization by organizations that an integrated philosophy and approach is necessary to achieve a successful information management environment.

Office automation can be described as the use of computer-based administrative support systems and any micro or minicomputers used in the office for machine-aided creation, communication, storage, retrieval, distribution and control of information handled by professionals, clerical and secretarial personnel; and time management and decision support purposes in an office environment. Low cost computing devices and their application software constitute not only the capability of providing complete local office automation support to DOD end users but also, when considered as intelligent peripherals provide the nodes upon which more extensive office information communications systems can be built.

The DOD office functions which could be supported by low cost computing technologies include:

- Document capture - Permits the entry of documents that are created external to the organization. These documents may be on multiple readable media (e.g., floppy disc, magnetic cards, etc.) or non-machine readable media (e.g., paper).
- Document creation - Permits the initial entry and correction of documents that originate within the confines of the DoD organization. This function also supports the editing of previously created documents and the merging of two or more existing documents to create a new document.
- Information communication - Involves the transmission and receipt of information between internal and external sources. This transmission may occur in a direct manner or in a store and forward manner and it may involve voice, image and text. This function includes electronic mail and teleconferencing.
- Information filing and retrieval - Involves the records management process and includes the functions of index, store search and retrieval.
- Format and output - Involves the printing, or the output to photo composers, the providing of an intermix of fonts, type sizes and the ability of the receiver to select the output media. This output can be printed, displayed or spoken.

Automated office systems can also provide security over information to prevent unauthorized access as well as accounting information to indicate the use of the resource by the Department or person. In addition, they can provide DOD users with terminal interfaces to other systems, such as financial management systems. This capability is what is called systems services.

A major trend in office automation systems is increased support to management and professional personnel. Related applications typically include:

- Decision support services - which help the professional evaluate data and make decisions for the corporate organization. An example would be the use of on-line financial statistics and analyses to prepare management reports. Many of these types of applications have been described previously in this chapter.
- Personal services - which assist the manager in administrating his own time and activities. Examples might include:
 - Automated calendar and schedule reminders

- Automated tracking of business contacts and correspondence.

In the context of the integrated office, these manager and professional services are usually available to the individual manager at his office location, perhaps even at his desk.

4. DEDICATED PROCESS CONTROL

The final area of low cost computing usage is process control. Process control is not a recent technology, but improvements have been made in this area because of the increasing capabilities of microprocessors. With more and more demands being placed on energy management systems for example, more sophisticated process control functions are being identified. In the past such systems were run on minicomputers, but with the capability to down-load these systems onto microcomputers, the new functions can be handled more efficiently at a lower cost.

5. MICROCOMPUTER CONFIGURATIONS

The physical configuration of microcomputer systems varies with the users' requirements. A typical stand-alone system consists of a central processing unit, video display, printer and floppy or hard disk drives. A multi-user stand-alone system may consist of a central processing unit, multiple video displays and keyboards, a printer, and disk drives. A shared system for multiple users can be configured with a central file server (which provides larger common storage capabilities) that can be accessed by smaller microcomputer systems connected through communications over telephone lines (a PBX system) or cabling. Microcomputers are increasingly being used as nodes in a variety of communications and applications. These include direct backup links for other microcomputers, links through common carriers (packet switched networks), dedicated links to in-house mainframes and links through local area networks. The real justification for a network appears to lie in the need to share information, not hardware. One of the most commonly cited justifications for local area networks is the ability to share "high cost" storage devices, i.e., hard disks. However, the validity of this argument is being diminished as those "high cost" devices continue to drop in price. For example, less than a year ago a 5 megabyte disk drive for the Apple III retailed for \$3,250. Today it is down around \$2000 and with quantity discounts can be obtained for \$1,600. Since a network interface runs around \$900 per station, in addition to cabling and the cost of the large shared disk, it is becoming cheaper to install a small hard disk on every machine rather than to share one large one.

With the exception of local area networks, most of the communications interfacing of the microcomputers is accomplished through relatively low speed RS232C serial connections using modems (which convert electronic signals for transmission into telephone lines) as appropriate. Local area networks operating over limited

distances are able to move information at significantly higher rates while remaining cost effective. This results in feasible systems for resource sharing, data sharing and electronic communication, i.e. electronic mail.

Some of the networks employ a star-shaped configuration (a central resource with stand-alone systems directly linking in), others loops (which enable stand-alone systems to communicate with other systems directly through the network), and others clusters (the central resource of one network serves as the focal point for communication with the central resource of another network). Some rely on a mini or mainframe to serve as the central node while others have no true central node, but may use file servers to provide common data storage. While these diverse configurations have their advantages and disadvantages in terms of cost, system reliability and so on, there is little room for management decision here since the topologies are more or less dictated by the technologies.

Management policy decisions will lie more in the area of network selection. Some vendors, Ungermann-Bass for example, are gearing their product at the mainframe/micro market while others such as 3COM are targeting the micronet market. With the availability of gateways to connect different types of local area networks, both types of network probably have their place in a large organization.

In the next chapter we discuss the management implications of the technology and application trends discussed in Chapters II and III of this report.

IV. MANAGEMENT IMPLICATIONS

IV. MANAGEMENT IMPLICATIONS

When all the trends in technology and market developments are put into perspective, what can be distilled as the key findings and implications for management? The purpose of this chapter is to revisit the management issues identified in our earlier study and present some answers based on what we learned about technology and the market. In the sections that follow, we present our analysis of key findings and a reevaluation of management issues.

1. ANALYSIS OF KEY FINDINGS

The key findings of our technology study are those that have long-term implications for how business is conducted in the Department of Defense. They include the following interrelated points:

- . The move towards end user computing and away from traditional data processing organizations
- . Dispersion of information processing resources and capabilities paralleling the shift to end user computing
- . Merging of the previously separate technologies for data processing, office automation and telecommunications
- . Continuing, dramatic improvements in price/performance ratios for both hardware and software coupled with extraordinary volumes of sales
- . The rapid rate of technological change which makes product life cycles much shorter than in the past
- . The availability of good, package solutions in hardware and software for applications that would in the past have required extensive custom development work
- . Economic forces in the market place that favor consumers with unusual displays of creative competition on the part of vendors.

Each of these key findings is discussed in the paragraphs that follow.

(1) Growth in End User Computing

The most critical finding of the technology study is the shift away from traditional sources of computing to end user computing. The extent of this phenomenon is reflected in Exhibit IV-1 following this page. (Source: Michael F. Trency, MIT SIO an School of Management Center for Information on Systems Research, Computer World, July 26, 1982) The exhibit displays percentages of computing handled by end users and by

DEFINITION OF AREA STUDIED GROWTH IN END USER COMPUTING

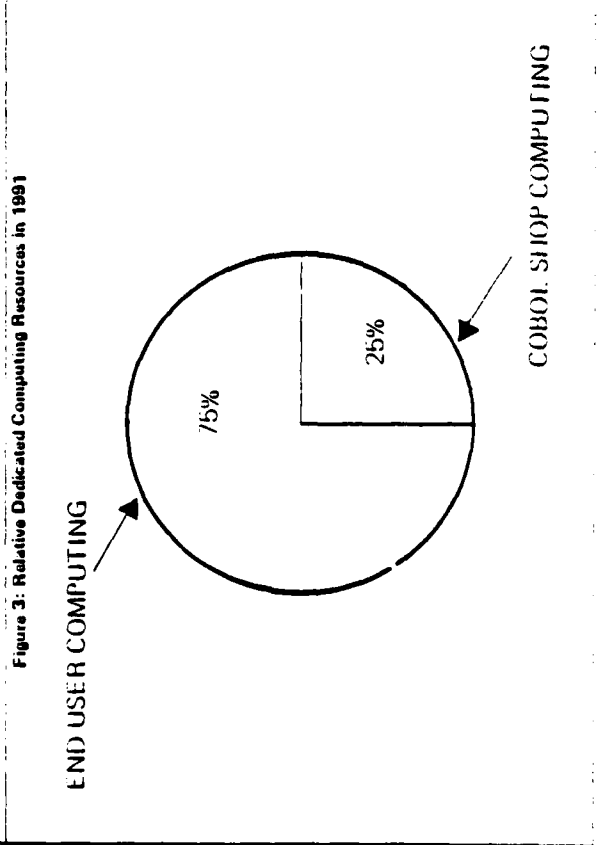
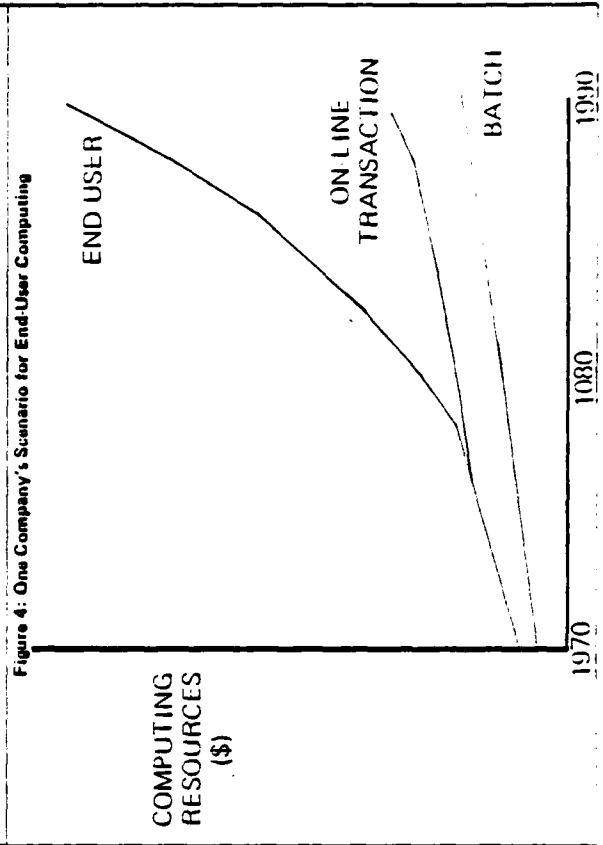
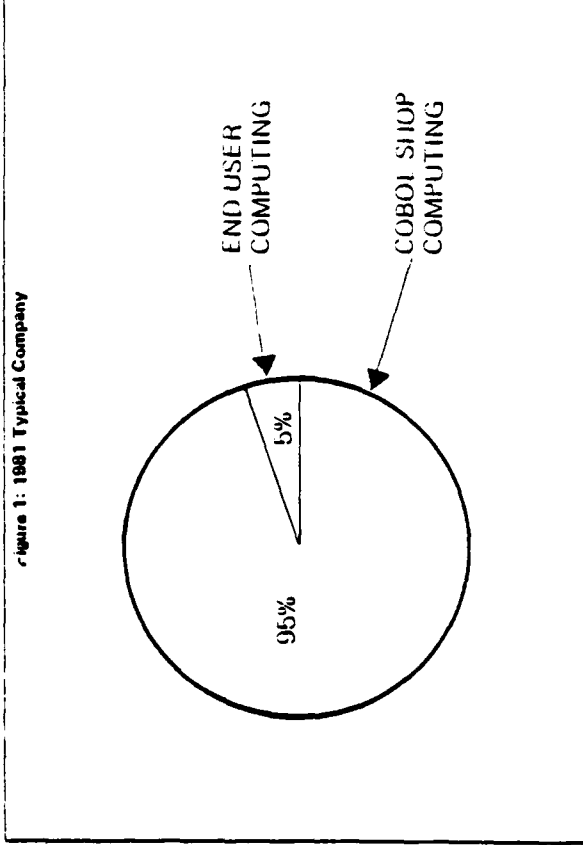
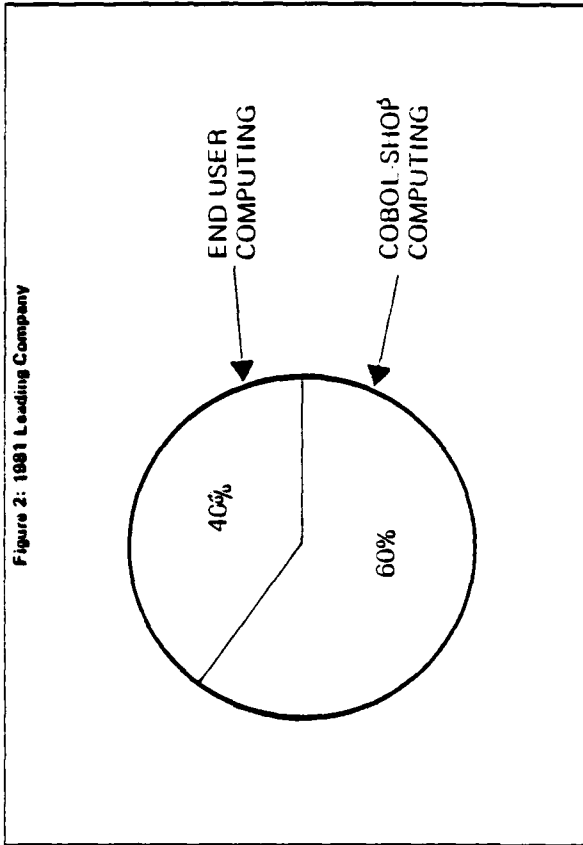

COBOL shops in 1981 at a typical company and a leading company. Predictions for how resources are allocated between central computing facilities and end user computing are also displayed. The shift is dramatic, with three quarters of the computing resources predicted to be dedicated to end users by 1991.

(2) Dispersion of Information Processing Resources

Paralleling the shift away from traditional computing to end user computing is the dispersion of information processing resources. Users not only will assume major responsibility for computing, they will perform their new functions wherever they currently work. This dispersion of resources makes the challenge of information management very real for the Department.

(3) Merging of Data Processing Office Automation and Telecommunications

Technologies which have been managed independently in the Department are becoming inseparable. New systems possibilities, particularly in the office productivity arena, require combinations of data processing, office automation and communications technologies in networks. Decisions in each area have cost and technical implications for the other areas. Finally, the management skills needed to exploit the potential of each area are similar. The interdependence of these technologies is not currently accommodated by the Department's management structure.

(4) Continuing Price/Performance Ratio Improvements

The market continues to offer improvements in technological capability at even lower costs. This continuing trend makes it important for the Department to encourage immediate use of available technology to achieve productivity gains. There may be a tendency on the part of some potential users to refrain from acquiring systems in anticipation of even greater savings in the near future. While the greater savings are probably predicted correctly, the cost of not achieving productivity gains in the short term is almost certainly higher than the cost of the system.

(5) Rate of Technology Change

The rapid rate of change in technology is critical for management because it increases the potential risks involved in long-term, large-scale investments in technology and diminishes the effectiveness of the Department's standards programs. While it is important to take advantage of short-term benefits (see point 4), it is equally important for management to recognize that change is inevitable and will probably offer attractive additional benefits. An approach of managed experimentation,

cautious investments and long-range planning for technology cycles, has become the most appropriate one the Department can adopt.

(6) Availability of Package Solutions

This finding is closely related to the growth in end-user computing and improving price/performance ratios. Users can, without attempting custom system development, find applications of technology that will meet their basic needs. The importance of package solutions lies in their cost-effectiveness. Many tasks that were not considered candidates for automation, because of the marginal return expected on a major investment, are now possible with off-the-shelf software and hardware costing less than \$10,000. Management needs to be aware of package solution potential and to channel users towards these solutions.

(7) Responsiveness of Market

The technology market is dominated by two strong factors: entrepreneurial inventiveness and competition. The result is that the computing market place is more responsive to the needs of users than it has ever been before. Vendors are taking on themselves problems users would traditionally have had to resolve or put up with. The market, furthermore, is solving problems more rapidly and effectively than the user community could hope to solve them. This unusual situation means management needs to reassess normal policy approaches, such as developing standards for computing acquisitions. These traditional approaches may be counter-productive in the current environment.

2. REEVALUATION OF MANAGEMENT ISSUES

In chapter I we restated the management issues that served as the impetus for this continuing study of technology:

- . How much control is needed, where and when is it needed, and through what means can it be most effectively applied?
- . How should effective micro/mini/mainframe architectures be built and what are the implications for the organizational structure and skills of the information processing community?
- . How can the most effective application areas be identified and what are the implications for the functional management community?
- . What price will best suit the needs, desires and capabilities of potential user group?

- . How should responsibilities be reassigned and how can DoD effectively achieve education and training goals?
- . How can the systems be acquired, maintained and operated most effectively?

In this section we present our conclusions concerning these issues, based on the key technology findings and implications discussed above.

(1) Control

Direct control over low cost computing systems most appropriately belongs to the managers who are using them. There is minimal need for central control. There is, however, a strong need for central planning. To support central planning, information on where and how and to what extent users are acquiring information processing resources is essential.

(2) Micro/Mini/Mainframe Architectures

There is no single solution to the question of how micros, minis and mainframes should interact. The strongest factor to consider in relation to this management issue is the market. These categories of systems are becoming indistinct. Vendors have identified it as in their interest to build compatible families of systems whose interoperability is guaranteed and transparent to the user community. It then becomes necessary for information processing professionals to develop skills in evaluating proposed architectures and to adopt the role of systems engineer consultant to the user community.

(3) Effective Application Areas

The predominant categories of application areas for new technology include spreadsheet analysis, data management, communications, word processing and graphics. Like the issue of architectures, the issue of applications has no single solution. The availability of these automated capabilities in small, inexpensive, easy-to-use packages is a challenge to functional managers. They need to reexamine how they do business in the light of technological advance. It becomes their critical responsibility to identify specific applications and to make sure they are pursued.

(4) Pace

Ordinarily, the pace of acquisition and installation of applications should be dictated by the functional management group. These are the individuals who know the skills and needs of the user community and who, therefore, can best predict when applications will be successful. However, in seeming contradiction to the high volume of sales, the pace of applications is slower than it should be. There are

productivity benefits to be realized from technology. They can only be realized if functional managers move from interested acquiescence to active proponency. Senior level education may encourage this shift and enhance the pace of improvement.

(5) Roles and Responsibilities

Two significant new roles have already been discussed. Information processing professionals need to become systems engineers and consultants to the user community; functional managers need to pick up the roles of systems analysis and operations management. Another realignment can be anticipated within the information processing community. The distinction among skills and organization structures needed to manage the merging technologies of data processing, office automation and telecommunications is blurring. The management structure for these technologies should be coordinated and integrated with functional management.

(6) Support Structures

New technology brings with it a need for innovative support structures to ensure efficient and effective acquisition, distribution, operations and maintenance. This need arises from the fact that information processing capabilities will be spread more widely, and among more diverse functional groups than has previously been possible. Individuals with no formal education or training in information processing will be assuming direct responsibility for many low cost computing systems. Information processing professionals need to leverage their skills and experience by building new structures to support users in assuming their new responsibilities.

The Department should consider establishing low cost computing consulting groups to assume responsibility for selected support activities from among the following:

- . Monitoring Technology Trends
- . Developing Low Cost Computer System Expertise in Selected Systems
- . Disseminating Current Technology Information
- . Assisting Users in System Selection
- . Trouble-Shooting During Operations & Maintenance
- . Evaluating Hardware
- . Evaluating Software Packages
- . Negotiating Volume Procurements

- . Designing/Delivering Training
- . Establishing and Operating Computer Stores
- . Building Compatible Micro/Mini/Maxi Architecture
- . Establishing a Central Demo Room
- . Offering Standard Application Systems
- . Establishing a Full-Scale Information Center.

* * * *

This chapter has presented summary technology findings and implications and used them as the basis for addressing key management issues. The resolution of these issues will be reflected in the development of policy and programs.

LMED
-8