

D-A130 007

# TECHNICAL LIBRARY

AD 7-130007

AD-E401 028

CONTRACTOR REPORT ARLCD-CR-83011

## DESIGN AND MANUFACTURE OF RIGID COMBUSTIBLE PROPELLING CHARGE CONTAINERS

**JACK HALEY**  
ARMTEC DEFENSE PRODUCTS, INC.  
85-901 AVENUE 53 - P.O. BOX 848  
COACHELLA, CA 92236

**SCOTT WESTLEY**  
PROJECT ENGINEER  
ARRADCOM

**JUNE 1983**



**US ARMY ARMAMENT RESEARCH AND DEVELOPMENT COMMAND  
LARGE CALIBER  
WEAPON SYSTEMS LABORATORY  
DOVER, NEW JERSEY**

**APPROVED FOR PUBLIC RELEASE; DISTRIBUTION UNLIMITED.**

**The views, opinions, and/or findings contained in this report are those of the author(s) and should not be construed as an official Department of the Army position, policy, or decision, unless so designated by other documentation.**

**The citation in this report of the names of commercial firms or commercially available products or services does not constitute official endorsement by or approval of the U.S. Government.**

**Destroy this report when no longer needed. Do not return to the originator.**

UNCLASSIFIED

SECURITY CLASSIFICATION OF THIS PAGE (When Data Entered)

REPORT DOCUMENTATION PAGE		READ INSTRUCTIONS BEFORE COMPLETING FORM
1. REPORT NUMBER Contractor Report ARLCD-CR-83011	2. GOVT ACCESSION NO.	3. RECIPIENT'S CATALOG NUMBER
4. TITLE (and Subtitle) DESIGN AND MANUFACTURE OF RIGID COMBUSTIBLE PROPELLING CHARGE CONTAINERS		5. TYPE OF REPORT & PERIOD COVERED
		6. PERFORMING ORG. REPORT NUMBER
7. AUTHOR(s) Jack Haley, Armtec Defense Products, Inc. Scott Westley, Project Engineer, ARRADCOM		8. CONTRACT OR GRANT NUMBER(s)  DAAK10-80-C-0172
9. PERFORMING ORGANIZATION NAME AND ADDRESS Armtec Defense Products, Inc. 85-901 Avenue 53, P.O. Box 848 Coachella, CA 92236		10. PROGRAM ELEMENT, PROJECT, TASK AREA & WORK UNIT NUMBERS
11. CONTROLLING OFFICE NAME AND ADDRESS ARRADCOM, TSD STINFO Div (DRDAR-TSS) Dover, NJ 07801		12. REPORT DATE June 1983
		13. NUMBER OF PAGES 29
14. MONITORING AGENCY NAME & ADDRESS (if different from Controlling Office) ARRADCOM, LCWSL Applied Science Div (DRDAR-LCA-G) Dover, NJ 07801		15. SECURITY CLASS. (of this report)  Unclassified
		15a. DECLASSIFICATION/DOWNGRADING SCHEDULE
16. DISTRIBUTION STATEMENT (of this Report)  Approved for public release; distribution unlimited.		
17. DISTRIBUTION STATEMENT (of the abstract entered in Block 20, if different from Report)		
18. SUPPLEMENTARY NOTES		
19. KEY WORDS (Continue on reverse side if necessary and identify by block number)		
acrylic fiber	matched metal molding	residue
cartridge case	modular charge	resin
combustible	nitrocellulose formulation	retainer
felting	spiral wrapping	
molding	talc	
20. ABSTRACT (Continue on reverse side if necessary and identify by block number)		
<p>The work covered by this report consisted of the design and manufacture of different length, combustible, rigid propellant containers as potential replacements for the bag charge presently in use. Matched metal molding and spiral wrapping processes were utilized with five different product formulations. No significant problems were encountered during manufacture. Both processes were successful in producing a chemically and dimensionally acceptable product. Marbon resin was successfully incorporated into the formula as a substitute for Durolok.</p> <p style="text-align: right;">(cont)</p>		

DD FORM 1473  
1 JAN 73

EDITION OF 1 NOV 65 IS OBSOLETE

UNCLASSIFIED

SECURITY CLASSIFICATION OF THIS PAGE (When Data Entered)

20. ABSTRACT (cont)

A process was developed to thicken the base of the rigid container or retention area by matched metal molding to improve seating the charge in the breech. The feasibility of producing modular containers of different lengths to allow assembly of different length charges was demonstrated.

## CONTENTS

	Page
Introduction	1
Process of Manufacture	1
Process Description	1
Batch Preparation	2
Felting	2
Molding	3
Spiral Wrapping	3
Contract Performance	3
Group A - Long Charge, 155-mm, Molded	3
Group B - Long Charge, 155-mm, Spiral Wrapped	4
Group C - Modular Charges, 155-mm, Molded	5
Group D - Design Study	6
Summary	6
Conclusions	7
Distribution List	25

## TABLES

	Page
1 Tooling list	9
2 Formulas and materials	10
3 Component composition	11
4 Chemical analysis	12
5 Dimensional inspection of group A--molded long tubes	13
6 Dimensional inspection of group B--spiral wrapped long tubes	14
7 Dimensional inspection of molded cases for modular charges	15

## FIGURES

1 Schematic of combustible production	17
2 Long charge, 155-mm, molded	18
3 Long charge, 155-mm, spiral wrapped	19
4 Modular charge, 155-mm, molded	20
5 Retention section	21
6 Die stack and removable insert	22
7 Female die insert	23

## INTRODUCTION

A number of combustible 155-mm bag charge assemblies were manufactured by both molded fiber and spiral-wrapping processes. These assemblies were required by ARRADCOM for evaluation of rigid combustible charges on containers as replacements for non-rigid bag charges currently in use for large caliber artillery. Use of a rigid charge has the potential for increasing weapon rate of fire by allowing automatic loading in addition to residue elimination and reduction in tube erosion.

The contract Scope of Work with modification consisted of nine tasks with subtasks involving three basic charge assemblies consisting of variations of fourteen components, design and fabrication of four tooling sets, and a study of a method of improving retention of the charge during seating in the weapon breech. The five basic formula compositions designated by the ARRADCOM project engineer consisted of variations in nitrocellulose, resins, and talc. Between July 1980 and July 1982, 1850 charge assemblies were produced by the molded and spiral-wrapping processes.

The tasks were broken down into four groups:

1. Group A--Tasks I, III, and IX--Long charges, molded
2. Group B--Tasks IV, VII, and X--Long charges, wrapped
3. Group C--Tasks V and VIII--Modular charges, molded
4. Retention Study--Task II

## PROCESS OF MANUFACTURE

### Process Description

The current state-of-the-art for molding of high density, combustible ordnance items evolved from various slurry preform and pressing techniques that were employed during the past century in the manufacture of three dimensional shapes from wood cellulose fibers. Basically, it is a commercial art for making hollow wares of a paperboard-type composition.

The present, controlled concept employed by Armtec in making high-density, combustible ordnance items is described in the following sections. The method described was employed to manufacture the spacer and sleeves applicable to this report (fig. 1).

## Batch Preparation

1. A hydropulper is filled with a predetermined amount of water.
2. A specified amount of acrylic fibers is added (previously fibrillated).
3. The mixture is beaten until the desired freeness is attained.
4. The contents are then pumped to a mixing tank.
5. The hydropulper is again filled with the proper amount of water.
6. A specific amount of Kraft fibers is added to the water.
7. The mixture is beaten until the desired freeness is attained.
8. A measured amount of nitrocellulose fibers is then added.
9. The entire batch is agitated for a few seconds until a homogeneous mix is obtained.
10. The homogeneous mixture is added to the mixing tank.
11. Resin is added within the mixing tank by employing the various prescribed steps that will obtain complete precipitation of the resin upon the fibers.
12. The batch is then pumped to a large intermediate tank, and sufficient water is added to reduce the slurry consistency to approximately 0.15% solids.
13. The batch is then allowed to stand under constant agitation for a minimum of one hour.
14. The slurry mix or batch is then pumped to a final supply tank where the mixture is kept in suspension by constant agitation, ready for use.
15. The slurry is pumped from the supply tank to the felting tank on a continuous basis. The slurry mixture is kept in constant agitation by mechanical methods.

## Felting

Preforms are made in the felting tank by vacuum accretion of the fibers onto a perforated and screened shape (felting die) having exterior dimensions comparable to the configuration of the open sleeve. The perforated shape is affixed to a minifold, which is connected to a vacuum source.

The felting die is immersed mechanically into the felting tank, and vacuum force is applied. The length of immersion time plus vacuum dictates the amount

of buildup of fibers around the exterior wall of the preform die. This, in turn, controls the weight of the preform.

When the preform, or felt, is removed from the felting die, it is a soggy, loosely woven matrix (approximately 60% water) with a wall thickness 3 1/2 times greater than the finished part to be molded.

The felting tank is rectangular. The slurry input is from the bottom center with a rectangular baffle mounted to give a 1/4-inch opening or slot between the baffle and the tank bottom, thus diffusing an equal amount of slurry in all directions. The felting tank is allowed to overflow equally over a weir and into a return trough on all four sides. This is designed to give the best possible distribution of the slurry mixture within the felting tank.

### Molding

The wet felt is dewatered and cured by a predetermined molding cycle in the steam-heated (350°F) matched metal dies. The male section of the die contains vertical grooves closely spaced on the die face. These grooves are connected to a manifold at the base of the male die. The manifold is connected to the vacuum source.

Dewatering is effected in two steps. First, the free water is literally squeezed out through the vacuum grooves during the die-closing operation. The remaining moisture is then vaporized by the die heat and is vented through the vacuum grooves.

The resin is cured during the closed-die cycle (which is approximately 3 1/2 minutes). The dried part is ejected from the male face by compressed air via the vacuum manifold and grooves.

### Spiral Wrapping

Standard commercial papermaking equipment is used to manufacture nitrocellulose (NC) paper rolls of the required formula. The rolls of NC paper are placed on a commercial spiral core-winding machine which is capable of producing tubing in a variety of diameters, lengths, and laminates. Shaped parts for tubes (bodies and rings) of appropriate sizes can then be produced. The one drawback to this process is its limitations to tubular components.

## CONTRACT PERFORMANCE

### Group A - Long Charge, 155-mm, Molded

Tasks I, III, and IX required the design and manufacture of two long charges and component parts (fig. 2): a 30.16-inch charge assembly with four component

parts (case body, base igniter ring, igniter cap, and base cap) and a 38.65-inch charge assembly with five component parts (case upper body, case lower body and the same base igniter ring, base cap, and igniter cap used on the 30.16-inch charge assembly). Identical tooling, except felting and molding tools for the upper body, was used for all tasks (table 1).

Tasks differed in product design (fig. 2); formula (table 2); and component composition (table 3). These differences were introduced to evaluate their effects with respect to residue, tube wear, and performance characteristics during firing.

Twenty-four formula batches were made to provide for felting and molding of required components. No significant batching, felting, or molding problems were encountered. Slightly higher off-press molded part weights and densities were encountered on components containing talc, as was expected due to the relatively high specific gravity of the talc.

All components molded for Group A were lathe-trimmed to dimension with specially designed trim mandrels. Components were assembled by hand into charge assembly configuration using acetone as a bonding agent. All components were chemically analyzed (table 4). Components were inspected for weight and dimension prior to assembly, as were the final charge assemblies. Results of the dimensional inspection are shown in table 5. No significant deviations were noted.

#### Group B - Long Charge, 155-mm, Spiral Wrapped

Tasks IV, VII and X required designing and manufacturing two long charges similar to those in Group A but replacing the molded case sidewalls with tubes spiral wrapped with NC paper. The resultant designs (fig. 3) were a 38.5-inch and 30.0-inch charge assemblies. These charges are identical from a design standpoint, with the exception of overall length, and consist of a spiral wrapped tube cut to length, two rings cut from spiral wrapped material, a molded base igniter container, two molded base caps, and a molded retainer.

The NC paper was manufactured by the Herty Foundation, Savannah, GA., recognized experts in this field. Spiral wrapping of the paper was performed by the Sunoco Corp. of Hartsville, South Carolina, specialists in spiral tube manufacture.

Raw materials to produce the required NC paper were supplied by Armtec to Herty Foundation, along with formulation instructions (tables 2 and 3). The paper was manufactured with standard paper-making equipment. The only difficulty was the interjection of talc on Formula HF-2 and uneven distribution of diphenylamine (DPA) on the first batch only. The paper was produced, calendered to thickness of 0.026-inch to 0.027-inch, and forwarded to Sunoco for tube manufacture.

At Sunoco the paper in rolls was slit to widths of 5 inches and 5 1/3 inches for use on their spiral-winding machine, a Sunoco designed-and-built piece of

equipment. Multiple rolls of the slit paper are fed under tension through an adhesive applicator onto a revolving mandrel. The strip material is fed on a bias, with each subsequent wrap crossing the seam of the previous wrap, thus providing the spiral tube configuration. The tubing is automatically forwarded on the mandrel to a cut-off blade where it is cut to length. The paper was wound on a mandrel producing a 6-inch-diameter tube at a winding speed of 27 linear feet of strip material per minute to produce 7.6 linear feet of 4-ply tubing per minute.

Sunoco used adhesive CHM 7950 (a Sunoco product) in initial winding runs. In some instances, the resulting tubing appeared weak and delaminated. After consultation with Armtec personnel, Sunoco substituted Rhoplex N-495 and Rhoplex LC-45 (Rohm and Haas products) for the adhesive in the remainder of the production. Sufficient tubing was then produced by Sunoco and delivered to Armtec for the required spiral-wrapped bodies and rings. (It should be noted that some firing test residue was subsequently traced to cases in which the CHM 7050 adhesive had been used.)

The cartridge case sidewall assemblies utilizing the spiral wrap tube material as produced by the core-winding machine reflected lower densities and strength characteristics than the molded sidewalls. As a result, on instruction of the ARRADCOM project engineer, half of the spiral-wrapped cases were impregnated with a two-component polyurethane resin for comparative testing with their unimpregnated counterparts. It is basically a polyol-di-isocyanate carried in xylene with a two-stage cure. Pick-up of resin solids on the 155-mm cases was 10%. Subsequent rough handling tests revealed no delamination on any of the spiral-wrapped parts.

Concurrently with the manufacture of the tubing for the spiral-wrapped components, Armtec procured the tooling (table 5) and produced the molded components to complete the assemblies required by these tasks. Five batches made to the two different formulations were required to produce the required molded components. Parts were felted, molded, and lathe-trimmed to dimension using special tooling (table 1). Components were hand-assembled with MR23 adhesive. All components were chemically analyzed (table 4). Components were inspected for weight and dimension prior to assembly, as were final charge assemblies. Results of the dimensional inspection are shown in table 6. No significant deviations were noted.

#### Group C - Modular Charges, 155-mm, Molded

Tasks V and VIII required the design and manufacture of modular charges of two different propellant bed lengths, with the modular charges being capable of fitting together in various combinations to form charges of various lengths. The resultant designs (fig. 4) were 9.0-inch and 6.54-inch modular charges. These charges were identical from a design standpoint with the exception of overall length and consisted of a body trimmed to length and a base. The modular charges were designed to fit together at final assembly, with the base of one modular charge forming a nest to receive the forward end of another modular charge. Significant to these tasks are the thin, untapered (cylindrical) sidewalls of the molded body section of the assembly.

Six formula batches were made to provide for felting and molding of required components (tables 2 and 3). A trial run using DOW 241 resin proved unsuccessful. After consultation with the ARRADCOM project engineer, Armtec replaced Dow 241 resin with Marbon 1600 and Durolok. Some difficulty was observed with batch foaming when the Marbon 1600 resin was used. Also noted was lower talc recovery, perhaps as a result of the foaming.

Tooling to produce the modular charges was fabricated by modification of existing tooling (table 1). Parts were felted, molded, and trimmed to length. No significant difficulties were noted despite the thin (0.80 inch) untapered sidewalls. All components were chemically analyzed (table 4). Components were inspected for weight and dimension prior to assembly, as were final charge assemblies. Results of the dimensional inspection are shown in table 7. No significant deviations were noted.

#### Group D - Design Study

Task II required the study and design of a means of improving the retention capability of a charge when inserted into the chamber of the gun. The specific requirement was to increase the diameter (from 6.30 inches to 6.80 inches). The height of the retention section is 0.85 inch. This modification will accommodate the chamber design of the 155-mm gun.

Two design approaches were evaluated: an add-on ring that would be bonded to the assembled charge and a molded base incorporating a larger diameter cap of 6.80 inch.

The idea of an add-on section was discarded early in the design study--primarily because of the possibility of unburned residue that would be caused by the thick cross section at the entrance base end of the charge and because the bonded section appeared to be more reliable.

The recommended configuration (fig. 5) is considered the most practical and cost effective. An insert is incorporated in the molding die (figs. 6 and 7) to give either configuration in a single molding operation. With the incorporation of either mold insert, the desired body section configuration can easily be produced. The concept has been proven workable. The necessary provisions have been incorporated in the tooling and the tooling is available for utilization.

#### Summary

All products were designed, manufactured, and shipped during the required timeframe. No significant problems were encountered.

Subsequent rough handling and firing tests revealed:

1. Minor glue assembly (ring-to-case) problems.
2. Igniter caps that showed inadequate strength in rough handling tests.

3. Firing residues in some cases. One type of residue, found in spiral-wrapped cases, was traceable to resin type and quantity. The other type of residue was traceable to quantity and location in the part of excessive talc.

#### CONCLUSIONS

Molded long charges in a variety of formulations may be readily made both as units and assemblies. Some work is still required in areas of choice of resin, techniques of assembly bonding, and ratio of talc and/or its location in the charge. Design work is necessary to improve tensile overall strength of rear components.

Spiral-wrapped long sidewalls are a viable alternative to molded sidewalls in the combustible charge. The state of the art indicates additional work is needed in the areas of wrapping adhesives and ratios. Talc may be introduced into the spiral wrapping paper formulations as it is in the molded charge formulations.

Molded modular charges in a variety of lengths and formulations can be readily made. The thin straight wall design opens up new areas of charge design and mechanical assembly techniques.

Table 1. Tooling list

<u>Description</u>	<u>Armtec drawing</u>	<u>Used for ARRADCOM drawing</u>	<u>Task</u>
Felter upper body cartridge case	151-4	9342962	I, III, IX
Upper body die assembly	151-2 (3 sheets)	9342962	I, III, IX
Felter lower body cartridge case	151-3	9342963 9342964	I, III, IX
Lower body die assembly	151-1 (4 sheets)	9342963 9342924	I, III, IX
Trimming mandrel spiral wrap	151-11	9344129	IV, VII, X
Inner cap base	151-6	9342967	I, III, IX
Cap and ring mold	151-5 (2 sheets)	9342965 9342966	I, III, IX I, III, IX
Trimming mandrel cartridge case	151-8	9342962 9342963 9342964	I, III, IX I, III, IX I, III, IX
Trimming mandrel components	151-9	9342965 9342966 9342967	I, III, IX I, III, IX I, III, IX
Felters for cap, ring igniter cap	151-7	9342965 9342966 9342967	I, III, IX I, III, IX I, III, IX
Modular body molding tool	138 SH 2,3, & 4	9344132	V, VIII
Trimming mandrel modular	138-3	9344132	V, VIII
Base molding tool	138 SH 6	9344130	V, VIII
Felter base	138 SH 7	9344130	V, VIII
Felter body	138 SH 8	9344132	V, VIII
155 molding tool assembly base ignition charge retainer	142 5 of 10	9344124	IV, VII, X
155 molding tool base cap	142 3 of 10	9344125	IV, VII, X
155 molding tool flash retainer	142 4 of 10	9344126	IV, VII, X
Felter for flash retainer	142 6 of 10	9344126	IV, VII, X

Table 2. Formulas and materials

ARRADCOM composition drawing	Formula no.	Composition (%)					
		NC <sup>a</sup>	DPA	Resins <sup>b</sup> (solids)	Kraft <sup>a</sup> (fiber)	Talc <sup>a</sup>	Kuralon <sup>a</sup> (fiber)
9344087	55	55	1	8	36		
9344088	72	72	1	10	17		
9344089	64T	64	1	14	11	10	
Herty paper (plain)	HF-1	57.3	1	10.4	26		5.2
Herty paper (w/talc)	HF-2	55.7	1	12.9	15.9	10.1	4.3

<sup>a</sup> Nitrocellulose (12.6% nitrogen) was furnished by the Government; Kraft paper (bleached sulfate) procured through Herty Foundation from Federal Paper Board Co., Riegelwood, NC; Talc from Cypress International, Inglewood, CA; "Kuralon" procured by Herty Foundation from Kuralay International (Sales office: 280 Park Ave., New York, NY); Duralok Resin and Catalyst from National Starch Co., Los Angeles, CA; Dow Latex 241 from Dow Chemical Co., Midland, MI; "Marbon" 1600 from Borg-Warner Corp.

<sup>b</sup> Duralok (National Starch Co.) resin was used on all molded parts with the exception of Task VIII, where Marbon 1600 was used, and Task IX, where Dow Latex 241 was used. Dow Latex 241 was used on all components made from spiral-wrapped Herty paper.

Table 3. Component composition

ARRADCOM drawing	Task I		Task III		Task IV		Task V		Task VII		Task VIII		Task IX		Task X	
	item 1	item 2	item 1	item 2	item 1	item 2	item 1	item 2	item 1	item 2	item 1	item 2	item 1	item 2	item 1	item 2
Group A - Molded Long Cases																
Forward end:																
9342963	55	64T														
9342962	55	64T	55	64T										55	64T	
Body basic																
Base end:																
9342965	72	72	72	72										72	72	
9342967	72	72	72	72										72	72	
9342966	72	72	72	72										72	72	
Base cap																
Group B - Spiral Wrapped Long Cases																
Forward end:																
9344125					72					72						72
9344125					55					55						55
9344127					HF-1					HF-2						HF-1
9344131-1										HF-2						HF-2
9344131-2					HF-1					HF-2						HF-1
Body																
Aft end:																
9335624					72					72						72
9344127					HF-1					HF-2						HF-1
9344132-2					72					72						72
Ring																
Base cap																
Group C - Modular Cases																
Body																
9344132-1																72
9344132-2																72
9344130																72
Body																
Base																

Table 4. Chemical analysis

Task	Required (%)				Actual (%)			
	NC	DPA	Kraft	Resin	Talc	NC	DPA	Kraft
Group A - Molded Long Cases								
Task I-1	55	1	36	8 Duralok		56.21	1.01	42.80
Forward	72	1	17	10 Duralok		76.55	1.20	22.25
Task I-2	64	1	11	14 Duralok	10	66.96	0.89	32.29
Forward	72	1	17	10 Duralok	10	75.03	1.09	23.05
Task III-1	55	1	36	8 Duralok		56.21	1.01	42.80
Forward (basic)	72	1	17	10 Duralok		69.26	0.70	30.04
Task III-2	64	1	11	14 Duralok	10	65.26	0.88	33.86
Forward (basic)	72	1	17	10 Duralok		69.26	0.70	30.04
Task IX-1	55	1	36	8 Dow Latex 241		56.46	1.01	43.03
Forward	72	1	17	10 Dow Latex 241		74.71	1.15	24.13
Task IX-2	64	1	11	14 Dow Latex 241	10	64.10	1.45	34.45
Forward	72	1	17	10 Dow Latex 241		72.88	1.10	26.02
Group B - Spiral Wrapped Long Cases								
Task IV	57.3	1	26	10.4 Dow Latex 241	5.2	58.42	1.13	40.45
Forward (spiral) I*	72	1	17	10 Duralok		72.67	0.96	26.37
Task VII	55.7	1	15.9	12.9 Dow Latex 241	4.3	64.85	1.01	34.14
Forward (spiral) I*	72	1	17	10 Duralok		72.88	1.10	26.02
Task X-1	57.3	1	26	10.4 Dow Latex 241	5.2	58.42	0.88	33.86
Forward (spiral) I*	72	1	17	10 Duralok		74.14	1.10	24.76
Task X-2	57.3	1	15.9	12.9 Dow Latex 241	4.3	64.85	1.01	34.14
Forward (spiral) I*	72	1	17	10 Duralok		72.24	0.99	26.76
Group C - Molded Incremental Modular Charges								
Task V	72	1	17	10 Duralok		72.83	1.08	26.09
Body Cap	72	1	17	10 Duralok		76.19	1.11	22.70
Task VIII	72	1	17	10 Marbon 1600		71.61	1.07	27.32
Body Cap	72	1	17	10 Marbon 1600		73.00	1.09	25.91

\* Reflects analysis of Herty paper. 1/2 of product produced was post impregnated with 10% polyurethane.

Table 5. Dimensional inspection of group A--molded long tubes

ARRADCOM drawing	Drawing dimensions (in.)	Dimensional results (in.)			
		Task I-1	Task I-2	Task III-1	Task III-2
9342961	38.65 ± 0.25 length	38.425 - 38.570	38.48 - 38.51		
9342961	5.855 ± 0.010 o.d. fwd end	5.850 - 5.854	5.859 - 5.860		
9342961	6.30 ± 0.010 o.d. aft end	6.303 - 6.316			
9342960	6.30 ± 0.010 o.d. aft end			6.300 - 6.314	6.292 - 6.300
9342960	30.16 ± 0.16 length			30.087 - 30.127	29.950 - 30.015
9342960	5.955 ± 0.010 o.d. fwd end			5.945 - 5.946	5.940 - 5.947
9342965	1.420 ± 0.010 length	1.410 - 1.118	1.410 - 1.435	1.409 - 1.417	1.410 - 1.440
	6.100 ± 0.101 o.d.	5.097 - 6.111	6.121 - 6.135	6.118 - 6.120	6.094 - 6.121
	0.100 ± 0.005 thickness	0.068 - 0.092	0.095 - 0.098	0.099 - 0.103	0.090 - 0.097
9342967	6.100 ± 0.010 o.d. flange	6.146 - 6.428	6.095 - 6.123	6.097 - 6.106	6.081 - 6.133
	6.150 ± 0.010 maj. i.d.	5.160 - 5.173	5.145 - 5.164	5.170 - 5.174	5.157 - 5.167
	0.080 ± 0.010 thickness	0.081 - 0.088	0.085 - 0.087	0.085 - 0.087	0.087
	0.75 ± 0.02 height inside	0.700 - 0.780	0.822 - 0.830	0.742 - 0.751	0.742 - 0.749
9342966	6.300 ± 0.010 o.d.	6.308 - 6.316	6.290 - 6.295	6.286 - 6.289	6.290 - 6.305
	0.100 ± 0.005 thickness	0.080 - 0.094	0.103 - 0.107	0.081 - 0.083	0.099 - 0.103
	0.125 ± 0.005 radius	0.123 - 0.124	0.130 - 0.134	0.110 - 0.118	0.138 - 0.140
	1.000 ± 0.010 height	0.990 - 0.955	1.000 - 1.020	1.002 - 1.010	0.095 - 1.004
	hole diameter	2.000 - 2.120	2.002 - 2.025	2.002 - 2.018	1.988 - 2.070
					6.300 - 6.319
					29.055 - 29.060
					5.949 - 5.953
					1.410 - 1.440
					6.076 - 6.096
					0.091 - 0.101
					6.097 - 6.106
					5.162 - 5.175
					0.082 - 0.089
					0.718 - 0.754
					6.292 - 6.300
					0.083 - 0.087
					0.115 - 0.118
					1.000 - 1.007
					2.008 - 2.010
					6.307 - 6.320
					30.104 - 30.162
					5.945 - 5.947
					1.415 - 1.420
					6.107 - 6.139
					0.080 - 0.100
					6.115 - 6.125
					5.616 - 5.168
					0.825 - 0.840
					6.280 - 6.296
					0.103 - 0.106
					0.130 - 0.131
					0.975 - 1.005
					2.029 - 2.040

Table 6. Dimensional inspection of group B--spiral wrapped long tubes

P/N	Drawing dimension	Task IV	Task IV impregnated	Task VII	Task VII impregnated	Task X-1	Task X-1 impregnated	Task X-2
9344131-1	38.40 length	38.257 - 38.285	38.250 - 38.276	38.193 - 38.289	38.260 - 38.360			
	5.99 ± 0.02 o.d.	5.982 - 5.990	5.975 - 5.982	5.988 - 5.993	5.973 - 5.975	30.074 - 30.108	30.040 - 30.083	30.015 - 30.055
9344131-2	30.0 length					5.977 - 5.986	5.975 - 5.980	5.981 - 5.991
	5.99 ± 0.02 o.d.							
9344125*	5.81 + 0.010 maj. i.d.	5.975 - 5.990						
	Hole diameter	2.018 - 2.046						
	1.00 + 0.010 height	0.998 - 1.10						
	0.125 ± 0.005 height slope	0.115 - 0.119						
9335624*	5.825 - 0.010 o.d. flange	5.760 - 5.761						
	0.080 ± 0.010 thickness	0.088						
	5.150 ± 0.010 i.d.	5.170 - 5.173						
	0.75 ± 0.02 height inside	0.743 - 0.750						
9344127*	1.525 - 0.050 height	1.532 - 1.575						
	0.080 + 0.005 thickness	0.082 - 0.089						

\* Common to all tasks.

Table 7. Dimensional inspection of molded cases for modular charges

Group B	APRADCOM drawing	Drawing dimension (in.)		Task V (in.)	Task VIII (in.)
Molded incremental cases	9344155-1, -2	1.21 ± 0.01	length of joint	1.218 - 1.263	1.218 - 1.224
	9344132-1	10.58 ± 0.020	length	10.591 - 10.599	10.588 - 10.598
	9344132-2	8.060 ± 0.020	length	8.111 - 8.117	8.055 - 8.081
	9344132-1, -2	5.870	max. o.d.	5.827 - 5.839	5.848 - 5.854
9324130		5.750 ± 0.005	o.d. shoulder	5.730	5.745
		5.505 ± 0.005	o.d. top	5.737	5.549
		0.080 ± 0.010	thickness	0.084 - 0.086	0.084 - 0.086
		1.125 ± 0.010	height--shoulder-top	1.114 - 1.124	1.118 - 1.125
		0.300 ± 0.010	height--top shoulder-top	0.294 - 0.302	0.294 - 0.299
		5.750 ± 0.005	o.d.	5.695 - 5.715	5.710 - 5.730
		0.29 ± 0.01	height lip inside	0.240 - 0.255	251.255
		5.150 ± 0.010	i.d.	5.160 - 5.165	5.160 - 5.165
		1.02 ± 0.02	height inside	1.040 - 1.048	1.038 - 1.044
		0.082 ± 0.010	thickness	0.093	0.091

1. KRAFT
2. NC
3. ACRYLIC FIBER
4. DPA
5. RESIN EMULSION

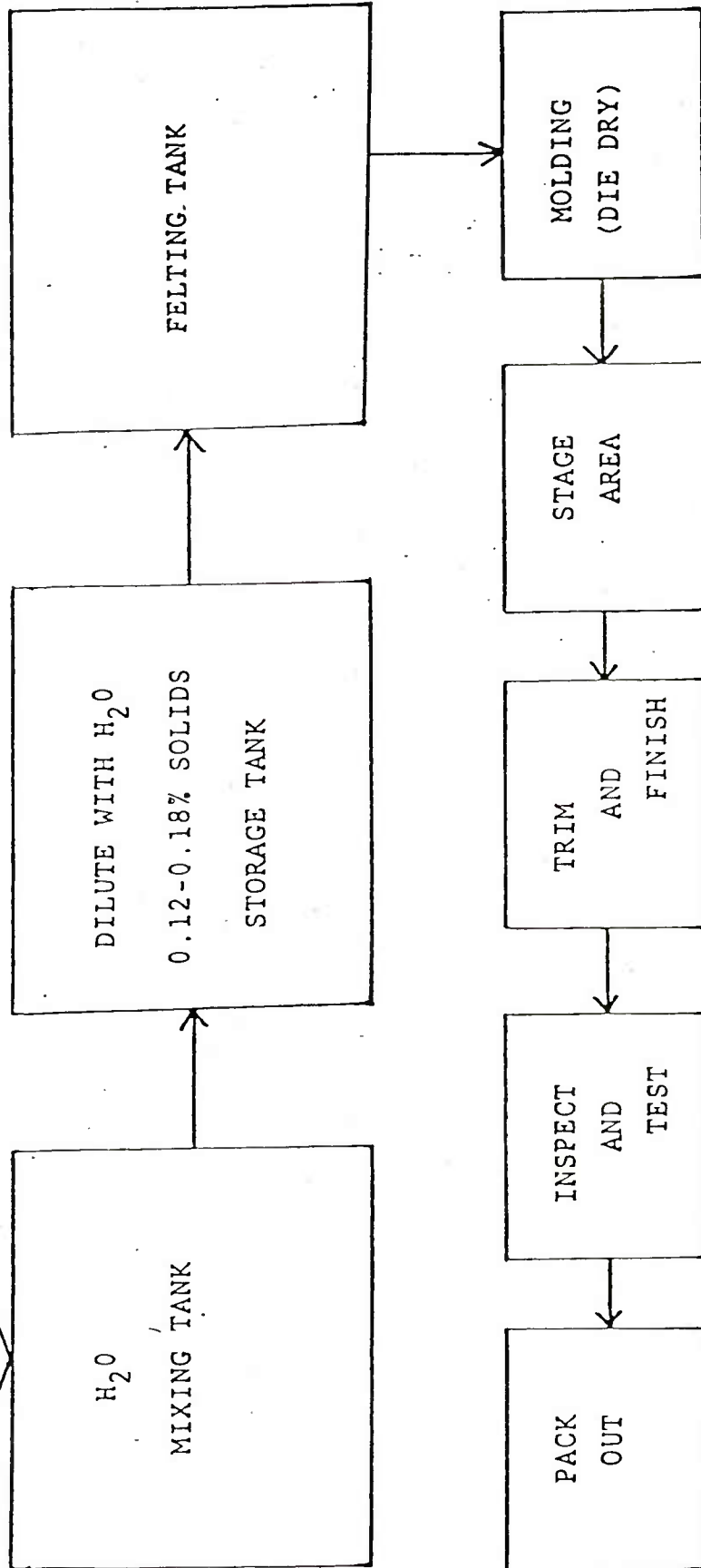

Figure 1. Schematic of combustible production

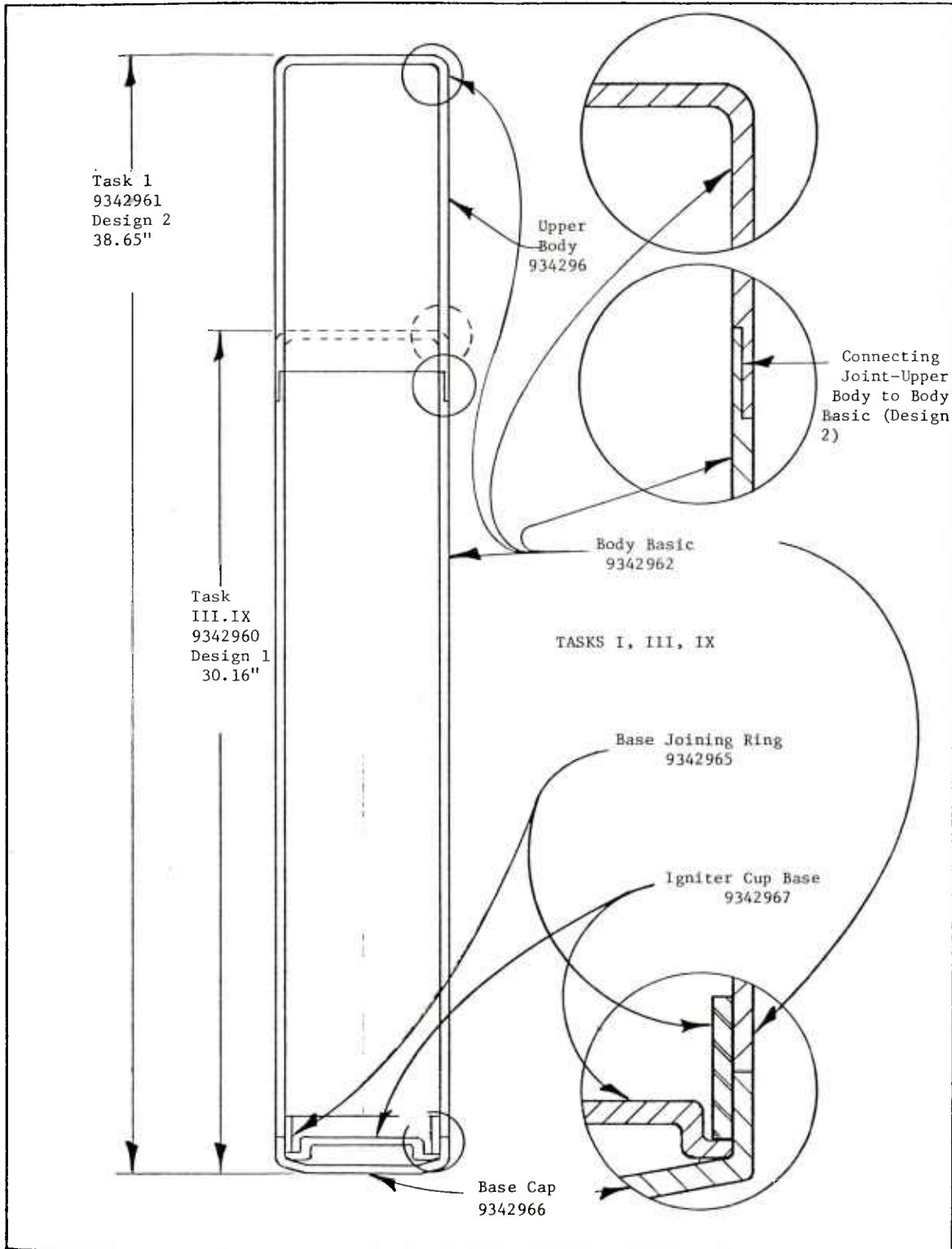

Figure 2. Long charge, 155-mm, molded

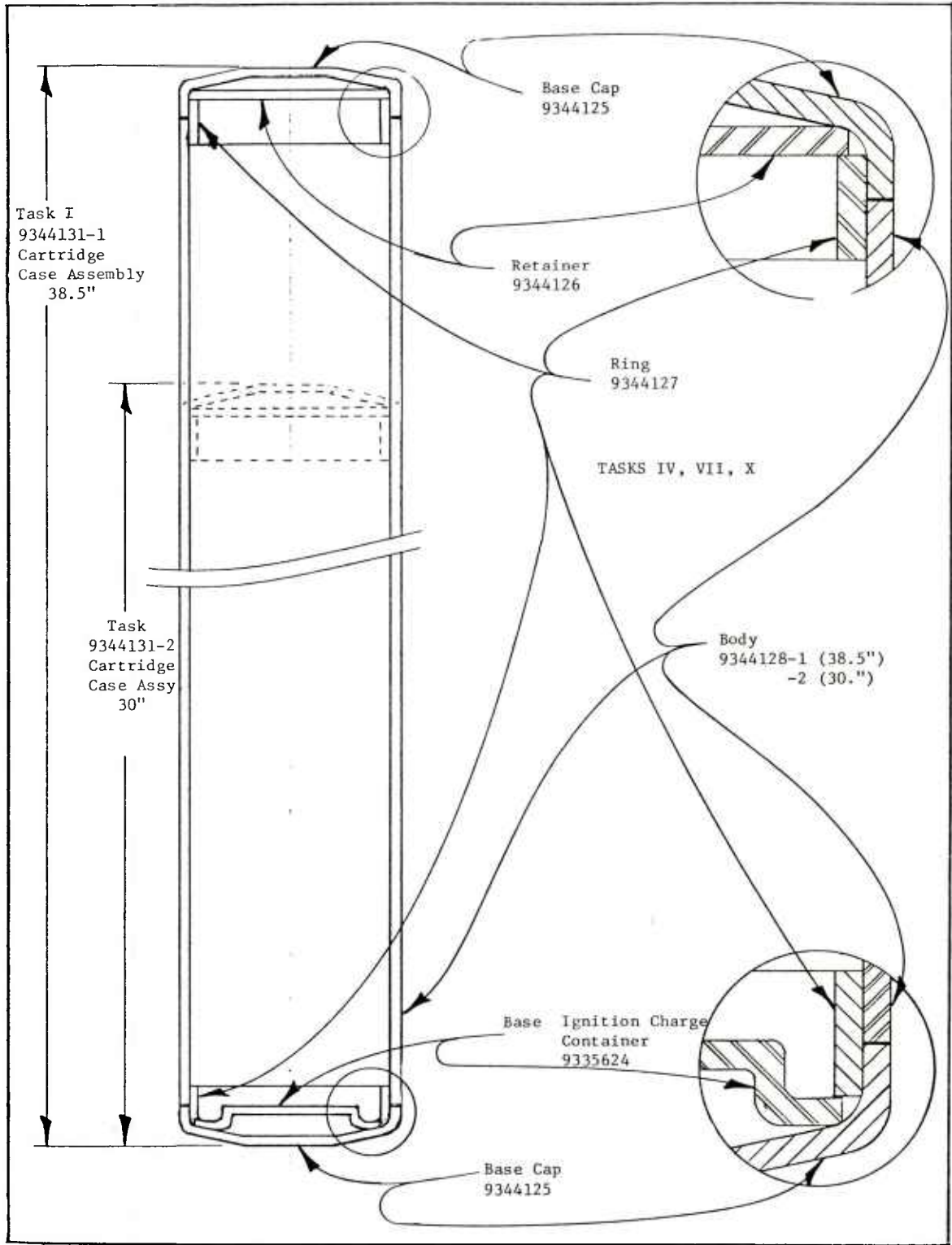

Figure 3. Long charge, 155-mm, spiral wrapped

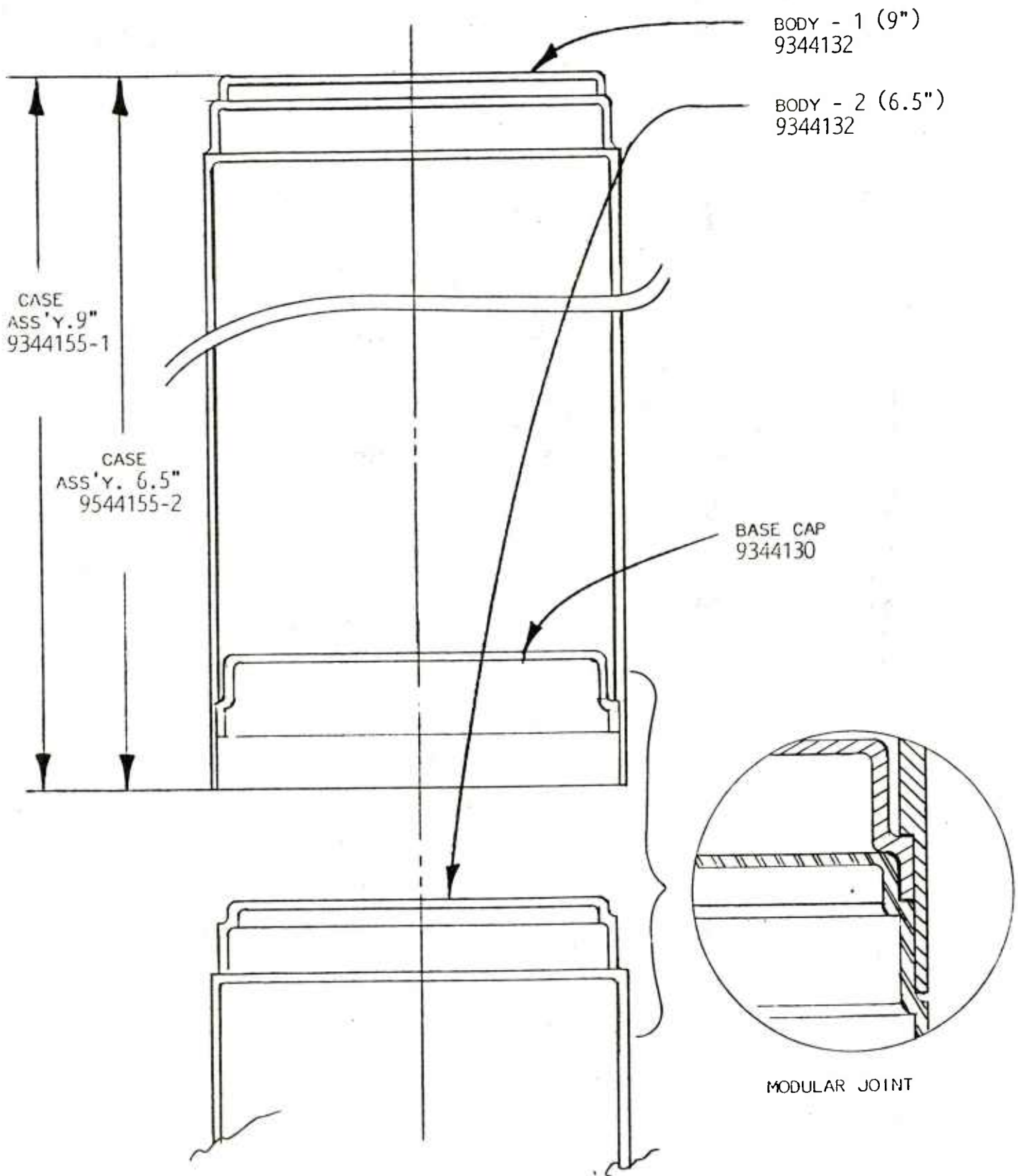

Figure 4. Modular charge, 155-mm, molded

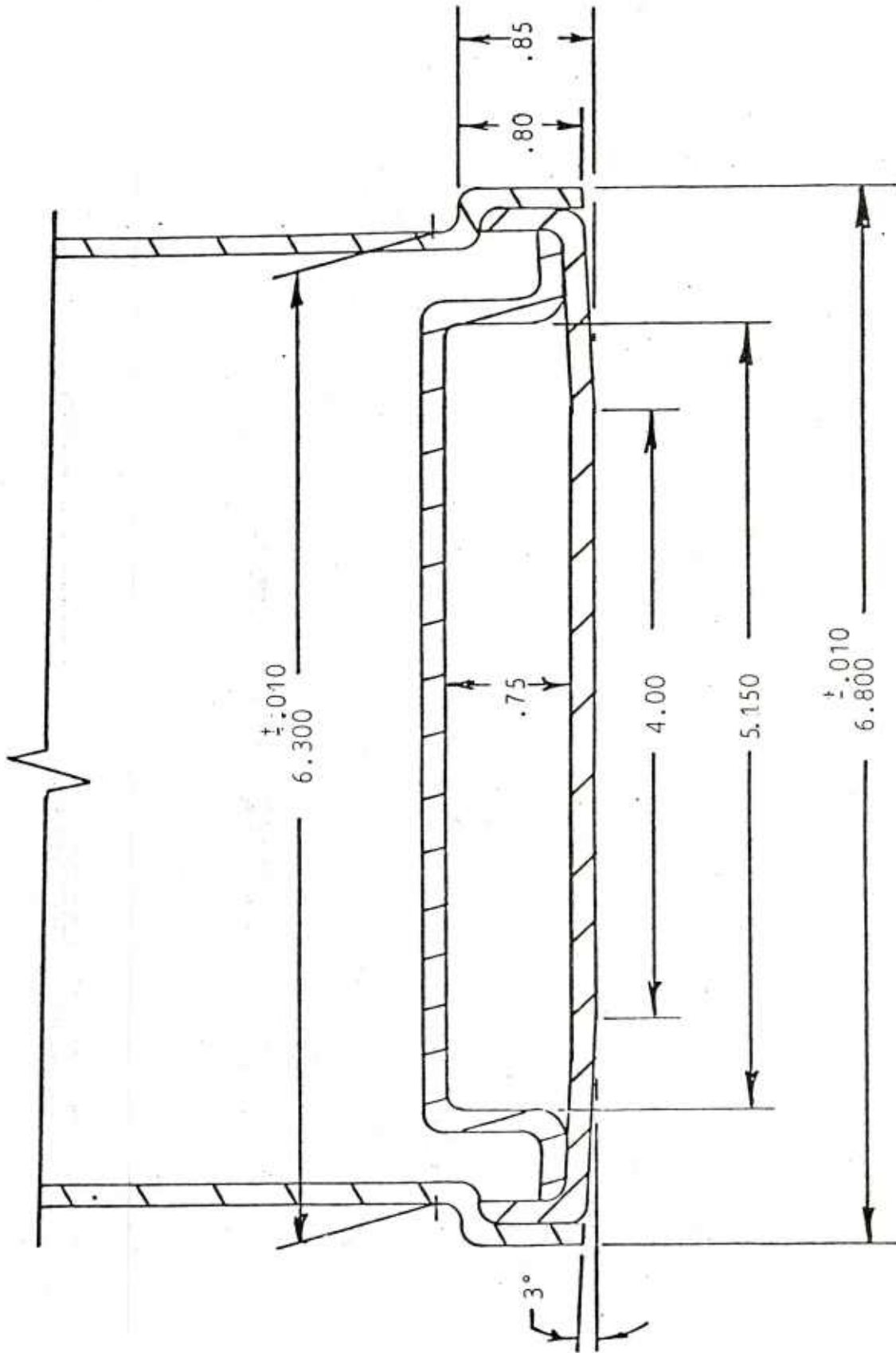

Figure 5. Retention section

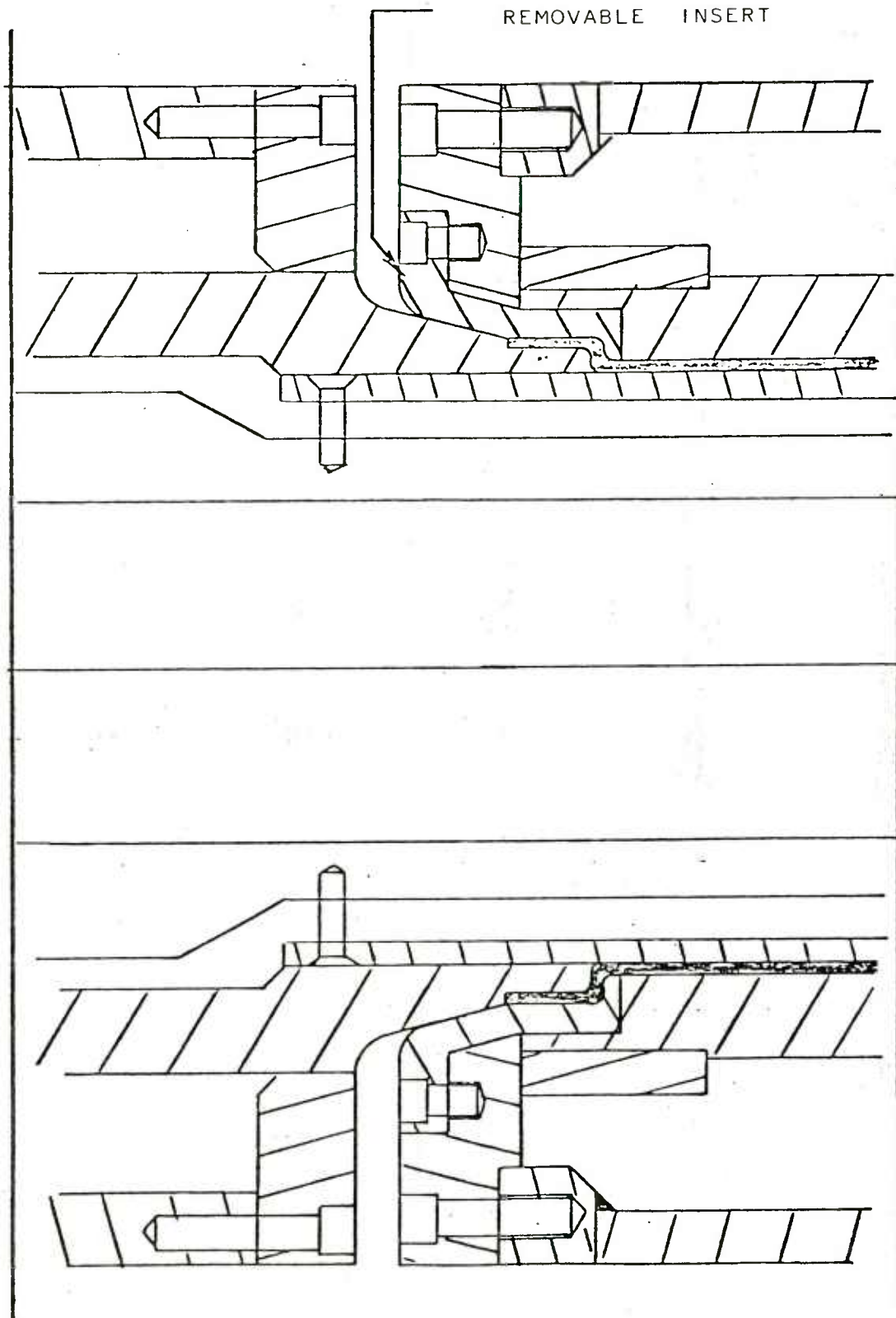

Figure 6. Die stack and removable insert

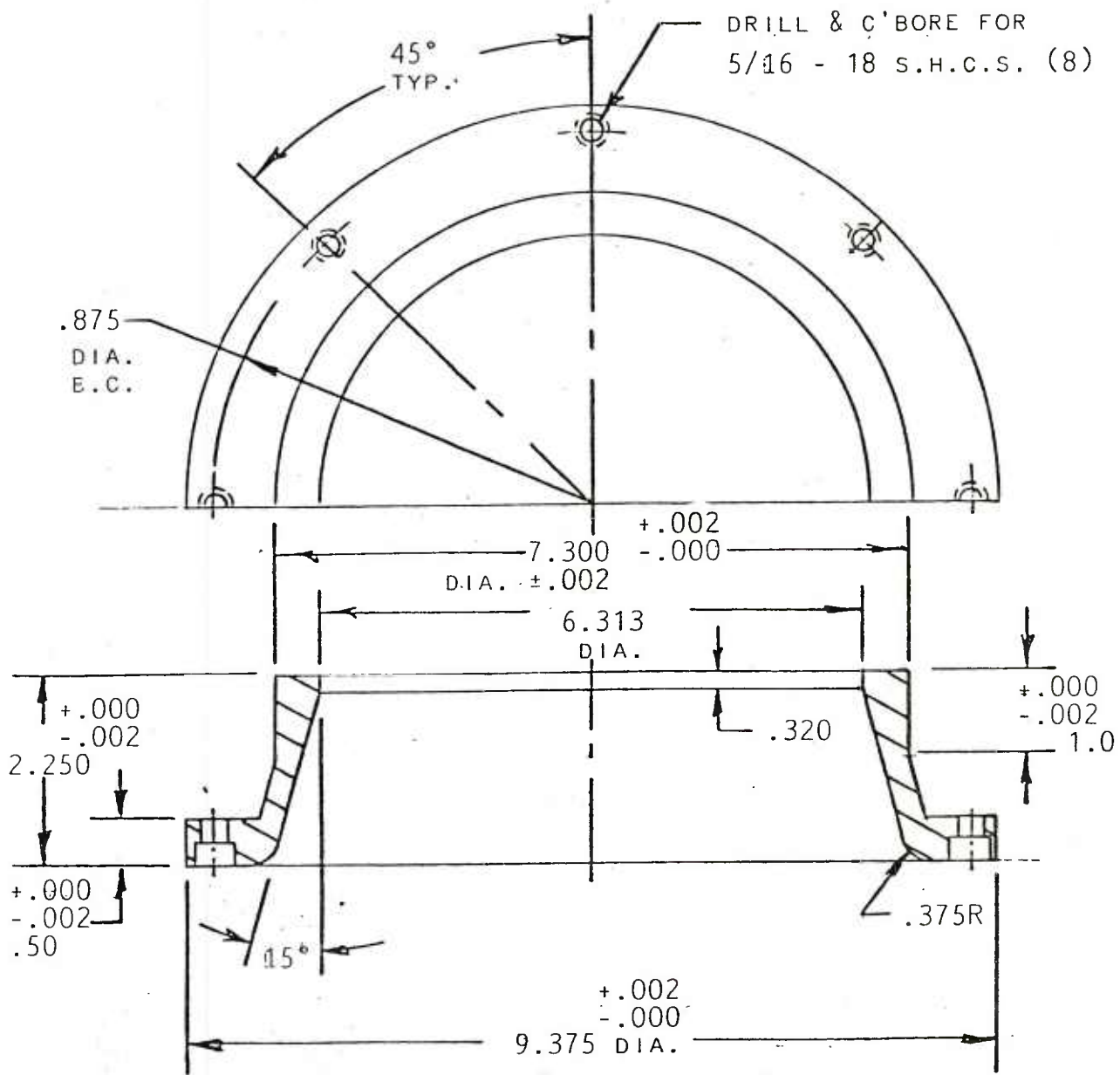

Figure 7. Female die insert

DISTRIBUTION LIST

Commander  
U.S. Army Armament Research and  
Development Command  
ATTN: DRDAR-LCA-G (12)  
DRDAR-TSS (5)  
Dover, NJ 07801

Administrator  
Defense Technical Information Center  
ATTN: Accessions Division (12)  
Cameron Station  
Alexandria, VA 22314

Director  
U.S. Army Materiel Systems Analysis Activity  
ATTN: DRXSY-MP  
Aberdeen Proving Ground, MD 21005

Commander/Director  
Chemical Systems Laboratory  
U.S. Army Armament Research and  
Development Command  
ATTN: DRDAR-CLJ-L  
DRDAR-CLB-PA  
APG, Edgewood Area, MD 21010

Director  
Ballistics Research Laboratory  
U.S. Army Armament Research and  
Development Command  
ATTN: DRDAR-TSB-S  
Aberdeen Proving Ground, MD 21005

Chief  
Benet Weapons Laboratory, LCWSL  
U.S. Army Armament Research and  
Development Command  
ATTN: DRDAR-LCB-TL  
Watervliet, NY 12189

Commander  
U.S. Army Armament Materiel  
Readiness Command  
ATTN: DRSAR-LEP-L  
Rock Island, IL 61299

Director  
U.S. Army TRADOC Systems  
Analysis Activity  
ATTN: ATAA-SL  
White Sands Missile Range, NM 88002

Armtec Defense Products, Inc.  
ATTN: Jack Haley (5)  
Gerald Perchetz (1)  
85-901 Avenue 53  
P.O. Box 848  
Coachella, CA 92236