

MICROCOPY RESOLUTION TEST CHART
NATIONAL BUREAU OF STANDARDS-1963-A

ADA130214

AFWAL-TR-83-4017



COMPOSITE LAMINATE WEIGHT OPTIMIZATION ON THE
TIMEX-SINCLAIR 1000 MICROCOMPUTER

GERALD V. FLANAGAN

MECHANICS AND SURFACE INTERACTIONS BRANCH
NONMETALLIC MATERIALS DIVISION

FEBRUARY 1983

Approved for public release; distribution unlimited.

DTIC FILE COPY

MATERIALS LABORATORY
AIR FORCE WRIGHT AERONAUTICAL LABORATORIES
AIR FORCE SYSTEMS COMMAND
WRIGHT-PATTERSON AIR FORCE BASE, OHIO 45433

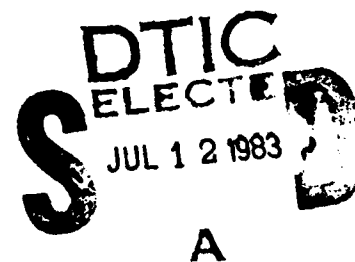

83 07 12 45

NOTICE

When Government drawings, specifications, or other data are used for any purpose other than in connection with a definitely related Government procurement operation, the United States Government thereby incurs no responsibility nor any obligation whatsoever; and the fact that the Government may have formulated, furnished, or in any way supplied the said drawings, specifications, or other data, is not to be regarded by implication or otherwise as in any manner licensing the holder or any other person or corporation, or conveying any rights or permission to manufacture, use, or sell any patented invention that may in any way be related thereto.

This report has been reviewed by the Office of Public Affairs (ASD/PA) and is releasable to the National Technical Information Service (NTIS). At NTIS, it will be available to the general public, including foreign nations.

This technical report has been reviewed and is approved for publication.

GERALD V. FLANAGAN, 1Lt, USAF
Mechanics & Surface Interactions Branch
Nonmetallic Materials Division

STEPHEN W. TSAI, Chief
Mechanics & Surface Interactions Branch
Nonmetallic Materials Division

FOR THE COMMANDER

FRANKLIN D. CHERRY, Chief
Nonmetallic Materials Division

"If your address has changed, if you wish to be removed from our mailing list, or if the addressee is no longer employed by your organization please notify AFNAL/MLBM, W-PAFB, Ohio 45433 to help us maintain a current mailing list.

Copies of this report should not be returned unless return is required by security considerations, contractual obligations, or notice on a specific document.

FOREWORD

This report was prepared in the Mechanics and Surface Interactions Branch (AFWAL/MLBM), Nonmetallic Materials Division, Materials Laboratory, Air Force Wright Aeronautical Laboratories, Wright-Patterson Air Force Base, Ohio. The work was performed under the support of Project Number 2307, "Nonmetallic Structural Materials", Task Number 2307P2, "Composite Materials and Mechanics Technology."

In this report, an automated composite laminate sizing technique is presented, which optimizes for minimum weight. The technique can be coded for a microcomputer and a listing is given for the Timex-Sinclair 1000. The program is interactive and easy to use. Ply ratios are optimized for point stress under multiple independent loads.

This program is available on cassette tape and can be obtained by sending a blank 15 or 30-minute tape to AFWAL/MLBM, Wright-Patterson AFB, Ohio 45433 and referencing this report.

TABLE OF CONTENTS

<u>SECTION</u>		<u>PAGE</u>
I	PROGRAM DESCRIPTION	1
II	GENERAL INSTRUCTIONS	2
III	METHOD	6
	APPENDIX A: Representative Results	13
	APPENDIX B: Subroutine Descriptions	19
	APPENDIX C: Variable List	23
	APPENDIX D: Notes on Sinclair Basic	29
	APPENDIX E: Listing	31

Accession For	
DTIC	<input checked="" type="checkbox"/>
DTIC TAB	<input checked="" type="checkbox"/>
Unannounced	<input type="checkbox"/>
Justification	
Distribution/	
Availability Codes	
Avail and/or	
Dist	Special
A	



SECTION I

PROGRAM DESCRIPTION

CLASS (Composite Laminate Automated Sizing for Strength) is an interactive optimization program designed to run on a small microcomputer. The listing presented here is for a Sinclair ZX81 or a Timex-Sinclair 1000 microcomputer with a 16K memory expansion. The version of Basic is standard enough that translations to other microcomputers is possible.

The program will find a minimum thickness laminate which will not fail under any of the load conditions entered. Ply orientations are chosen by the user. The program's capability in handling multiple, independent, loads could be useful for loads which change with time or for situations where there is uncertainty in calculating the loads. As the program is currently dimensioned, four independent load combinations and 18-ply orientations can be entered.

Only point stresses are considered, thus the program optimizes the laminate only at one point in the structure. Furthermore, the program assumes in-plane loads only and no out-of-plane deflections. This implies a symmetric laminate, but stacking sequence is not a factor in the program. The layer thicknesses generated by the program are the total and must be divided by 2 to get the halves of a symmetric laminate.

No knowledge of optimization techniques is needed to run the program and very little knowledge of laminate plate theory is needed. In addition, material properties for five common advanced composites are stored in the program, or the computer can ask for new properties through prompts.

SECTION II

GENERAL INSTRUCTIONS

The Timex 1000 or Sinclair ZX81 manual includes tape loading instructions. Because CLASS takes so long to read (approximately 7 minutes), its a good idea to test tape player volume level with a short one or two line program to see if all is well. Load the tape using "CLASS" as the name. If the tape loads properly, it will automatically begin execution. An example of the video prompts and appropriate responses are given in this report. As a number is entered, it appears at the bottom of the screen. The number can be changed using the delete key (shifted zero). Once ENTER is pressed, there is no way to change entries until the end of the input sequence when the program asks for corrections. If there are mistakes, answering "Y" to this query will restart the sequence. A subroutine is included for making a hardcopy of input and results if a printer is available. At the completion of the routine, after all results have been displayed, the program will restart itself.

Run times can be quite long. They range from a minute for a 2-layer laminate, to an hour for an 18-layer laminate subject to multiple loads.

Much of the information included in this report is intended for those who wish to understand and modify the program and is not needed to run it.

Display

- 1) T300/5208
- 2) BORON/5505
- 3) AS/3501
- 4) SCOTCHPLY 1002
- 5) KEVLAR 49/EPOXY
- 6) AVAILABLE
- 7) NEW

SELECT MATERIAL

HOW MANY PLY ANGLES

ENTER PLY ORIENTATION (DEGREES)

PLY 1 =

PLY 2 =

ENTER NUMBER OF INDEPENDENT LOADING
CONDITIONS

ENGLISH OR SI UNITS (E/S)

LOADING CONDITION 1

N1 =

N2 =

N6 =

ENTER ENGINEERING CONSTANTS IN GPA

EX = ?

EY = ?

VX = ?

ES = ?

Keyboard Response and Comments

(Tapes will automatically start after loading)

(6 is an available slot for a user defined material. Entering 7 allows new properties to be placed in the slot. These properties can be used in subsequent runs by entering 6)

7 ENTER

2 ENTER

0 ENTER

90 ENTER

1 ENTER

E ENTER

4000 ENTER

1E3 ENTER

ENTER

(either scientific or explicit notation may be used to enter numbers)

181 ENTER

10.3 ENTER

.28 ENTER

7.17 ENTER

ENTER STRENGTHS IN MPA.

X (TENS.) = ?

X (COMP.) = ?

Y (TENS.) = ?

Y (COMP.) = ?

SHEAR = ?

ENTER MATERIAL NAME (< 15 CHARC)

CORRECTIONS (Y/N)

(blank screen for 100 seconds)

TOTAL LAMINATE THICKNESS
.029706293 IN

2 ACTIVE CONSTRAINTS AFTER 2
ITERATIONS

PRESS ANY KEY TO CONTINUE

ANGLE	RATIO	NO. PLIES
0	0.7542	4.55
90	0.2458	1.48

PRESS ANY KEY TO CONTINUE

STRENGTH RATIOS

1 = ULTIMATE STRAIN: > 1 = SAFE

PLY	LOAD1
0	1
90	1.03

1500 ENTER

1500 ENTER

80 ENTER

246 ENTER

68 ENTER

T300/EPOXY(2) ENTER

(the numbers just entered are simply those of T300/5208 with double the normal transverse strength. If materials 1-5 had been selected, all of the material property prompts would have been skipped by the computer)

N ENTER

(this simply gives the user a chance to restart the input routine before the calculations start)

(actually any key except BREAK which will stop the program. If BREAK is used, the program can be restarted with CONT)

B

Press any key to continue

HARDCOPY (Y/N)?

BAR GRAPH (Y/N)?

- 1) T300/5208
- 2) BORON/5505
- 3) AS/3501
- 4) SCOTCHPLY 1002
- 5) KEVLAR 49/EPOXY
- 6) T300/EPOXY(2)
- 7) NEW

SELECT MATERIAL

B

(useful if printer is attached)

N ENTER

(useful if many ply angles are used. Shows relative thickness of layers)

N ENTER

(program automatically restarts at beginning. Note that user defined material is now number 6 and can be used without re-entering the properties)

SECTION III

METHOD

The goal is to minimize the total thickness of a composite laminate subject to failure constraints under static loads. Specifically

$$\sum_{k=1}^L h_k = \min. \quad \text{where } L = \text{number of layers}$$

subject to $h_k \geq 0$

and $G_{ij}^{(\theta_k)} \epsilon_i^{(N)} \epsilon_j^{(N)} + G_i^{(\theta_k)} \epsilon_i^{(N)} - 1 \leq 0$ where h_k is the total thickness of all the plies at the k th orientation (which will be referred to as a "layer" in this report). The failure criteria is a first ply failure based on the Tsai-Wu tensor criteria in strain space. The G 's are transformed to the laminate axis from the k 'th layer's orientation. The strains are associated with the N 'th loading combination. This distinction is made since more than one independent loading may be considered. For the definition of the G 's in terms of experimental strength data, see reference 1.

Stacking sequence is not included in this formulation, and the laminate is assumed not to bend or warp. Therefore, strains and loads are related by

$$\vec{N} = [A] \vec{\epsilon}$$

The optimization method applied is a modification of the method of feasible directions.² The method can be demonstrated graphically with 2-dimensions, i.e. two layers. In Figure 1 the two equalities

$$G_{ij}^{(0)} \epsilon_i \epsilon_j + G_i^{(0)} \epsilon_i - 1 = 0$$

$$G_{ij}^{(90)} \epsilon_i \epsilon_j + G_i^{(90)} \epsilon_i - 1 = 0$$

have been plotted as functions of $h^{[0]}$ and $h^{[90]}$ for the single loading condition shown. Any point above and to the right of these two curves is feasible, that is, failure will not occur. Points to the left and below the curves are infeasible. Because our objective function (the sum of the layer thicknesses) is linear, the optimum point will lie on one of these curves or the intersection of multiple curves.

The program starts by finding an initial feasible point (A) which lies on a constraint curve farthest from the origin on the line $h^{[90]}=h^{[0]}$. The distance from the origin is calculated using a strain ratio method. Along any vector which passes through the origin

$$h_k^{i+1} = h_k^i \cdot S/S_0$$

where S is a scalar distance and

$$S_0 = \left[\sum_{k=1}^L (h_k^i)^2 \right]^{1/2}$$

along this vector, strain can be found using

$$\epsilon_i = \frac{\epsilon_i^0 S_0}{S}$$

where ϵ_i^0 is a component of laminate strain evaluated at S_0 . Substituting into the failure criteria we have

$$\frac{G_{ij}^{(\theta_k)} \epsilon_i^0 \epsilon_j^0 S_0^2}{S^2} + \frac{G_i^{(\theta_k)} \epsilon_i^0 S_0}{S} - 1 = 0$$

To ensure the calculated point lies slightly in the feasible region despite any numerical error, the program sets this function equal to the negative of a small number (E_1) rather than zero. Solving this equation for positive S we have

$$S = \frac{-B + \sqrt{B^2 - 4AC}}{2A}$$

where

$$A = 1 - E_1$$

$$B = \sum_{i=1}^3 -G_i^{(\theta_k)} \epsilon_i^{\circ} S_0$$

$$C = \sum_{i=1}^3 \sum_{j=1}^3 -G_{ij}^{(\theta_k)} \epsilon_i^{\circ} \epsilon_j^{\circ} S_0^2$$

If S_0 lies in the feasible region we solve the above equation for each layer and each load combination then take the smallest resulting S as the one that defines the boundary of the feasible region.

The next step in the optimization procedure is to establish a direction vector which will point away from the constraint A lies on and is parallel to the plane defined by $\Sigma h_k = \text{constant}$. In Figure 1, this direction is shown as Z . Finding Z first requires calculation of the gradient of the active constraint evaluated at A . Let

$$C_{k,N} = G_{ij}^{(\theta)} \epsilon_i^{(N)} \epsilon_j^{(N)} + G_i^{(\theta)} \epsilon_i^{(N)} - 1$$

where k and N correspond to the layer and load combination of the active constraint. A constraint is considered active if

$$C_{k,N} \geq -E_2$$

where E_2 is a small number. Note that more than one constraint may be active.

The gradient is then given by

$$\vec{\nabla} C_{k,N} = \sum_{L=1}^L G_{ij}^{(\theta_k)} \left(\frac{\partial \epsilon_j^{(N)}}{\partial h_L} \epsilon_j^{(N)} + \epsilon_j^{(N)} \frac{\partial \epsilon_i^{(N)}}{\partial h_L} \right) + G^{(\theta_k)} \frac{\partial \epsilon_i^{(N)}}{\partial h_L} \hat{h}_L$$

where \hat{h}_L is a unit vector. To find the partials of strain we start with the basic equation

$$\vec{N} = |A| \vec{\epsilon}$$

$$0 = \frac{\partial}{\partial h_i} |A| \vec{e} + A \frac{\partial}{\partial h_i} \vec{e}$$

$$\frac{\partial \vec{e}}{\partial h_i} = -|A^{-1}| \frac{\partial}{\partial h_i} |A| \vec{e}$$

and

$$\frac{\partial}{\partial h_i} |A| = \begin{bmatrix} Q_{11}^{(\theta i)} & Q_{12}^{(\theta i)} & Q_{13}^{(\theta i)} \\ Q_{21}^{(\theta i)} & Q_{22}^{(\theta i)} & Q_{23}^{(\theta i)} \\ Q_{13}^{(\theta i)} & Q_{23}^{(\theta i)} & Q_{33}^{(\theta i)} \end{bmatrix} = [Q_i^{(\theta i)}]$$

The gradient vector is normalized to unit length. If more than one constraint is active, the normalized gradients are summed together and the sum is then normalized to one. The negative of the gradient will point away from the constraint, into the feasible region. This vector is now projected onto the plane defined by the unit normal \hat{n} , where

$$\hat{n} = \frac{1}{\sqrt{L}} \sum_{i=1}^L \hat{h}_i$$

The projection can be made with a double cross product

$$\vec{Z} = \hat{n} \times (-\vec{\nabla}c \times \hat{n})$$

With a vector identity, this can be rewritten as

$$\vec{Z} = (\vec{\nabla}c \cdot \hat{n})\hat{n} - \vec{\nabla}c$$

Finally, \vec{Z} is also normalized to unit length.

Along \vec{Z} , another constraint will eventually be reached (point B in Figure 1). The point is found iteratively by a bisection technique. Since

the bisection method is very time consuming, the constraint line is only found within a relatively large error band. What we are really interested in is a point approximately midway between A and B, which is C in the figure. From point C, the strain ratio technique is used to analytically calculate D. Starting at D, the entire procedure repeats. The program terminates when the distance \overline{AB} or \overline{CD} is small (say 1/10 a ply thickness) or the magnitude of \vec{Z} before normalization is very small (implying \hat{n} and \vec{v}_c are almost parallel).

In some cases, $h_k \geq 0$ constraint may be reached. When this happens, that orientation is completely dropped from further calculations. Thus, the constraints associated with a zero thickness layer cannot effect the results. Once an orientation reaches zero thickness, it is never reinstated in later iterations.

Figure 1 shows a case where the program reaches the intersection of two constraints. However, simultaneous failure should not be considered a criteria for optimization. Figure 2 shows a case where only one layer approaches failure. The constraint line for the +45° layer is completely in the infeasible region. The line $h^{[45]} + h^{[-45]} = \text{const.}$ has been included to show that point D is the minimum thickness.

References

1. S. W. Tsai, H. T. Hahn, Introduction to Composite Materials, Technomic Publishing Company, Westport, Connecticut, 1980.
2. D. M. Himmelblan, Applied Nonlinear Programming, McGraw-Hill, New York, 1972.

APPENDIX A

REPRESENTATIVE RESULTS

Comments

 MATERIAL T300/5208
 TOTAL THICKNESS .000666667 M
 AFTER 3 ITERATIONS

N1= 1000000 N/M
 N2= 0 N/M
 N6= 0 N/M

ANGLE	RATIO	NO. PLYS
0	1	5.33
90	0	0
45	0	0
-45	0	0

Demonstrates program's capability to eliminate unnecessary layers.

STRENGTH RATIOS
 1=FAILURE: >1=SAFE
 PLY LOAD1
 0 1

 MATERIAL T300/5208
 TOTAL THICKNESS .0076394812 M
 AFTER 4 ITERATIONS

N1= 1000000 N/M
 N2= 1000000 N/M
 N6= 1000000 N/M

N1= 2000000 N/M
 N2= 1000000 N/M
 N6= 0 N/M

N1= 2000000 N/M
 N2= -1000000 N/M
 N6= 0 N/M

N1= 0 N/M
 N2= 0 N/M
 N6= -1500000 N/M

ANGLE	RATIO	NO. PLYS
0	0.3072	18.77
45	0.2335	14.27
-45	0.2471	15.1
90	0.2122	12.97

Multiple load capability

STRENGTH RATIOS
 1=ULTIMATE STRAIN: >1=SAFE
 PLY LOAD1 LOAD2 LOAD3 LOAD4
 0 1.242 1.819 2.398 1.278
 45 2.132 1.497 1.263 1.819
 -45 1.813 1.474 1.261 2.467
 90 1.387 1.294 1 1.27

Comments

 MATERIAL T300/5208
 TOTAL THICKNESS .0055896009 M
 AFTER 3 ITERATIONS

N1 = 2000000 N/M
 N2 = 1000000 N/M
 N6 = 0 N/M

N1 = 1750000 N/M
 N2 = 1250000 N/M
 N6 = 433012.7 N/M

ANGLE	RATIO	NO. PLYS
0	0.3546	15.86
90	0.1583	7.08
45	0.3064	13.7
-45	0.1807	8.08

Note that this $\pi/4$ laminate and the $\pi/6$ laminate on the next page give the same total thickness.

Second load has the same magnitude as the first only with the principle axis rotated 30°.

STRENGTH RATIOS
 1=ULTIMATE STRAIN: >1=SAFE

PLY	LOAD1	LOAD2
0	1.261	1.123
90	1.001	1.118
45	1.034	1.307
-45	1.2	1

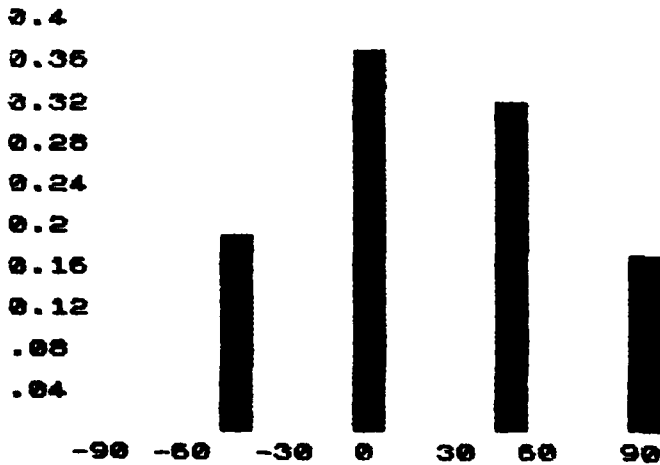

Bar Graph. Vertical scale is the ply ratio; horizontal is orientation angle.

Comments

 MATERIAL T300/5200
 TOTAL THICKNESS .0055897041 M
 AFTER 2 ITERATIONS

Same loads as previous example.

N1= 2000000 N/M
 N2= 1000000 N/M
 N3= 0 N/M
 N1= 1750000 N/M
 N2= 1250000 N/M
 N3= 433012.7 N/M

ANGLE	RATIO	NO. PLIES
-60	.099	4.43
-30	0.1564	7
0	0.2426	10.85
30	0.2434	10.88
60	0.1564	7.06
90	0.1002	4.48

STRENGTH RATIOS
 1=ULTIMATE STRAIN: >1=SAFE

PLY	LOAD1	LOAD2
-60	1.125	1.015
-30	1.275	1.006
0	1.254	1.103
30	1.097	1.257
60	1	1.275
90	1.01	1.127

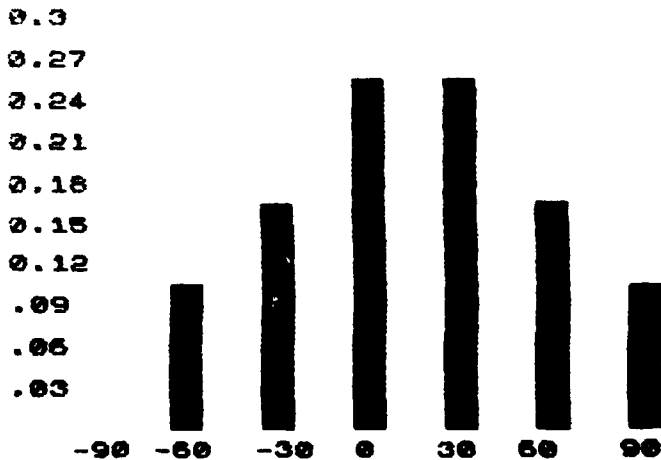

18 layer laminate

 MATERIAL T300/5200
 TOTAL THICKNESS 0.11247529 M
 AFTER 10 ITERATIONS

N1 = 40000000 N/M
 N2 = 10000000 N/M
 N6 = 0 N/M

N1 = 12500000 N/M
 N2 = 32500000 N/M
 N6 = 12990000 N/M

ANGLE	RATIO	NO. PLIES
-80	.009	8.13
-70	0	0
-60	0	0
-50	0	0
-40	0	0
-30	.0537	48.35
-20	.099	89.1
-10	0.1175	105.82
0	0.1059	95.3
10	.0742	66.81
20	.0414	37.22
30	.0252	22.68
40	.0342	30.8
50	.0633	56.93
60	.0963	86.66
70	0.1138	102.41
80	0.1028	92.52
90	.0634	57

Second load is of the same magnitude as the first but principle axis is rotated 60°. These loads have been exaggerated by an order of magnitude. This has the effect of making the program run for more iterations.

STRENGTH RATIOS
 1=ULTIMATE STRAIN: >1=SAFE
 PLY LOAD1 LOAD2

-80	1.023	1.389
-70		
-60		
-50		
-40		
-30	1.449	1.004
-20	1.574	1
-10	1.652	1.015
0	1.649	1.05
10	1.566	1.11
20	1.44	1.201
30	1.311	1.325
40	1.201	1.461
50	1.117	1.648
60	1.058	1.775
70	1.021	1.801
80	1.004	1.711
90	1.005	1.554

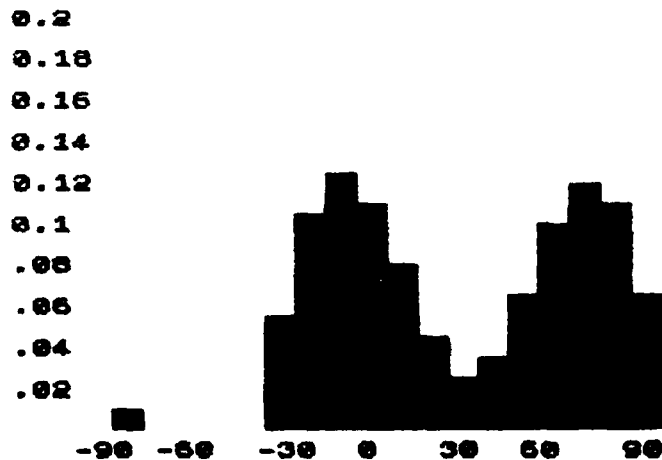

Peaks at -10° and 70°.

Comments

 MATERIAL T300/5208
 TOTAL THICKNESS .011037472 M
 AFTER 2 ITERATIONS

Same loads as 18 layer example.

N1 = 4000000 N/M
 N2 = 1000000 N/M
 N6 = 0 N/M

N1 = 1250000 N/M
 N2 = 3250000 N/M
 N6 = 1299000 N/M

ANGLE	RATIO	NO. PLYS
-10	0.5215	46.05
70	0.4785	42.25

Selecting "peak" orientations results in a laminate with about the same total thickness as the 18 layer case.

STRENGTH RATIOS
 1=ULTIMATE STRAIN: >1=SAFE
 PLY LOAD1 LOAD2
 -10 1.364 1.007
 70 1 1.569

 MATERIAL T300/5208
 TOTAL THICKNESS .022791632 M
 AFTER 3 ITERATIONS

Same loads as last two cases.

N1 = 4000000 N/M
 N2 = 1000000 N/M
 N6 = 0 N/M

N1 = 1250000 N/M
 N2 = 3250000 N/M
 N6 = 1299000 N/M

ANGLE	RATIO	NO. PLYS
0	0.2911	53.08
90	0.7089	129.25

With only two orientations, angle sensitivity is important. Here a small change to [0/90] has resulted in a laminate twice as thick as for [-10/70].

STRENGTH RATIOS
 1=ULTIMATE STRAIN: >1=SAFE
 PLY LOAD1 LOAD2
 0 2.224 1
 90 1.32 1.018

APPENDIX B

SUBROUTINE DESCRIPTIONS

500-760 CONSTRAINT TEST

Test each possible failure constraint. If a constraint is violated, set $G\beta$ = "FAIL" and return. If no constraints are violated, set $G\beta$ = "PASS", make a list of active constraints, and set NC (no constraints).

1000-1270 GRADIENT

Find the gradient of the constraint identified by ply P and load N.
Normalize the gradient to unit length.

1500-1760 STRAINS

Given a value of S find $|A| = |A_h| + |A_z|xs$. Invert $|A|$ and calculate laminate strains for each independent loading.

2000-2170 FORM A_h AND A_z

$$A_{h,ij} = \sum_{k=1}^L Q_{ij}^k h_k; \quad A_{z,ij} = \sum_{k=1}^L Q_{ij}^k z_k$$

Note that at a distance S along Z, $|A| = |A_h| + |A_z|xs$

2200-2290 FORM Q

Convert C array to 3x3 matrix for ply II.

2400-2498 FORM G

Convert B array to 3x3 matrix for ply II. Also form vector s which contains linear components of failure parameters.

2500-2800 NEW H

Two step procedure. First find approximate distance along vector Z to next constraint. At a point half that distance, use the strain ratio

routine to decrease the total thickness with constant ply ratios until a constraint is found.

3000-3350 NEW DIRECTION

Find a feasible direction vector which is parallel to the iso-thickness plane and leads away from the active constraints.

3500-3650 STRAIN RATIO

Along a vector pointing to origin, find a scalar distance from current location in h space to the nearest constraint.

4100-4400 INITIAL FEASIBLE POINT

Using an assumption of equal thickness plies, find the first point where no constraints are violated. Initialize A_h , A_2 , h, strains, and constraint list.

4500-4780 TRANSFORMATIONS

For each ply orientation, transform Q and G. Store the results in B and C.

5000-5495 INPUT

Prompt user for material, angles and loads.

5500-5658 OUTPUT

Video display of results.

5660-5820 STRENGTH RATIO

Used by OUTPUT and HARDCOPY to print out a list of strain ratios for each loading.

5870-5950 PLY RATIO

Used by OUTPUT and HARDCOPY to print out a list of ply ratios and number of plies.

6500-6670 HARDCOPY

If printer attached, makes a printout of results.

7000-7200 NEW MATERIAL

Prompts user for new material properties.

7500-7740 HISTOGRAM

Generates a bar graph.

8000-8760 INVARIANTS

Given engineering constants and strengths, form invariants.

APPENDIX C

VARIABLE LIST

Arrays

- A (3,3) - a matrix for current value of thickness vector
- B (18,9) - contains transformed G's (strength parameters in strain space) for each ply in the sequence $G_{11}, G_{22}, G_{12}, G_{66}, G_{16}, G_{26}, G_1, G_2, G_3$. First subscript is ply number, second is G element.
- C (18,6) - contains transformed Q's (modulus components) for each ply in the sequence $Q_{11}, Q_{22}, Q_{12}, Q_{66}, Q_{16}, Q_{26}$. First subscript is ply number, second is Q element.
- D (3,3) - $\sum Q_{ij}^k Z_k$ where \vec{Z} is the direction vector
- E (4,3) - strains corresponding to each independent loading. First subscript identifies load, second is strain component.
($\epsilon_1, \epsilon_2, \epsilon_6$)
- G (3,3) - strength parameter matrix for a given ply orientation
- N (4,3) - loads. First subscript identifies independent loading, second is load element (N_1, N_2, N_6)
- P (3,3) - A inverse
- Q (3,3) - modulus matrix for a given ply orientation

Vectors

- H (18) - thickness for each ply
- R (3) - intermediate results
- S (3) - linear strength parameter components for a given ply orientation
- T (18) - angle of each ply in radians
- U (5) - modulus invariants
- V (7) - strength invariants (strain space)
- W (18) - normalized gradient of a constraint
- X (18) - normalized sum of gradients from all active constraints
- Y (3) - intermediate results
- Z (18) - direction vector

Scalars

- E2 - defines minimum move along direction vector before terminating program
- E5 - defines an active constraint (if $G_{ij}\epsilon_i\epsilon_j + G_i\epsilon_i - 1 > -E5$ then constraint active)
- E6 - small factor included in strain ratio routine to guarantee the point found is slightly in the feasible region, despite numerical error
- C2 - $\cos 2\theta$
- C4 - $\cos 4\theta$
- S2 - $\sin 2\theta$
- S4 - $\sin 4\theta$
- S - final scalar distance to be moved
- S1 - point in feasible region in bisection routine
- S2 - point in infeasible region in bisection routine
- SREF - distance to origin used by strain ratio routine
- SMAX - distance along direction vector to first $h = 0$ constraint
- SI1 - units conversion lb/in \rightarrow N/m
- SI2 - units conversion m \rightarrow in
- NPLY - number of ply orientations
- NL - number of independent loadings
- NC - number of active constraints
- ITER - iteration counter
- IMAX - iteration limit
- M - identifies material
- EX, EY, VX, ES - engineering constants (reused as strength parameters in stress space)
- XT, XC, YT, YC, SS - strengths
- QXX, QYY, Qxy, Qs - modulus
- GXX, GYY, GXY, GSS, GX, GY - strength parameters in strain space

TPLY - thickness of an individual ply
I, J, K, L - loop counters
P, II - ply orientation pointers
N - load pointer
A, B, C, CON, DET, E, NORM, TEST - intermediate calculations
Z - $\sqrt{NPLY^*}$ where NPLY* is number of ply orientations for which $h_i \neq 0$

Strings

C\$ (10,2) - list of active constraints, identified by ply and loading
P\$ (6,19) - material engineering constants
Y\$ (6,24) - material strengths
M\$ (6,15) - material names
R\$ (4,2) - engineering constant labels "EX", "EY", "VX", "G"
S\$ (5,8) - strength labels "X (Tens.)", "X (Comp.)", etc.
F\$ - flag to halt program when = "Fail"
G\$ - flag returned from constraint test routine = "Fail" if a constraint is violated
K\$ - "Press any key to continue"
U\$ - units label for load
V\$ - units label for thickness
E\$ - when = "E" English units are desired
A\$,H\$ - query responses

Constants entered from keyboard

If the program is loaded from tape, it will be ready to run. If the program is keyed into the computer, certain constants and dimension statements have to be entered before running the program. These have not been defined in the program in order to save memory. When the program is

SAVEd on tape, the constants and dimensions will also be saved. Once the constants have been entered, do not use the RUN command as this will erase all the data.

Dimension Statements

Dim A (3,3)	Dim H (NPLY)
Dim B (NPLY,9)	Dim R (3)
Dim C (NPLY,6)	Dim S (3)
Dim D (3,3)	Dim T (NPLY)
Dim E (NL,3)	Dim U (5)
Dim G (3,3)	Dim V (7)
Dim N (NL,3)	Dim W (NPLY)
Dim P (3,3)	Dim X (NPLY)
Dim Q (3,3)	Dim Y (3)
Dim C§ (10,2)	Dim Z (NPLY)
Dim P§ (6,19)	Dim M§ (6,15)
Dim Y§ (6,24)	Dim R§ (4,2)
	Dim S§ (5,8)

Where NPLY is the number of ply orientations allowed and NL is the number of independent loads. NPLY = 18 and NL = 4 will use all available memory in the ZX81.

CONSTANTS

M§(1)="T300/5208"
P§(1)="181.,10.3,0.28,717"
Y§(1)="1500,1500,40.0,246.,68.0"
M§(2)="BORON15505"
P§(2)="204.,18.5,0.23,5.59"
Y§(2)="1260,2500,61.0,202.,67.0"
M§(3)="AS/3501"
P§(3)="138.,8.96,0.30,7.10"
Y§(3)="1447,1447,51.7,206.,93.0"

M₃(4) = "Scotchply/1002"
P₃(4) = "38.6,8.27,0.26,4.14"
Y₃(4) = "1062,610.,31.0,118.,72.0"
M₃(5) = "Kevlar 49/Epoxy"
P₃(5) = "76.0,5.50,0.34,2.30"
Y₃(5) = "1400,235.,12.0,53.0,34.0"

Let SI1 = 175.1567

Let SI2 = 39.37008

Let R₃(1) = "EX"

Let R₃(2) = "EY"

Let R₃(3) = "VX"

Let R₃(4) = "S"

Let S₃(1) = "X(TENS.)"

Let S₃(2) = "X(COMP.)"

Let S₃(3) = "Y(TENS.)"

Let S₃(4) = "Y(COMP.)"

Let S₃(5) = "SHEAR"

Let K₃ = "PRESS ANY KEY TO CONTINUE"

Let E2 = 1E-5

Let E5 = 1E-1

Let E6 = 1E-6

Let TPLY = 1.25E-4

Let IMAX = 10

APPENDIX D

NOTES ON SINCLAIR BASIC

The version of BASIC used on the ZX81 should be easily translatable to other machines. There are some nonstandard features however, which may require explanation.

SLOW, FAST - The ZX81 uses these commands to control whether video display is continuous or goes blank during computations. They can be ignored for other machines.

A\$(α to β) - TO is the string slicing command and replaces the standard LEFT\$, MID\$ and RIGHT\$. Note that string slicing is used to define material properties. This is used since the ZX81 lacks READ, DATA and RESTORE.

LPRINT - Sends string to printer.

COPY - Sends entire video display to printer

PAUSE 40000 - An indefinite pause, broken by pressing any key

Displays in the program are designed for a screen that has 21 lines with 32 characters.

APPENDIX E

LISTING

MAIN

```
110 LET ITER=1
130 GOSUB 5000
130 PRINT "CORRECTIONS ? (Y/N)"
134 INPUT A$
136 IF A$="Y" THEN GOTO 130
140 IF M=7 THEN GOSUB 7000
150 GOSUB 8000
242 GOSUB 4500
246 GOSUB 4100
250 GOSUB 3000
260 IF F$="FAIL" THEN GOTO 5500
290 GOSUB 2500
300 IF F$="FAIL" THEN GOTO 5500
302 LET ITER=ITER+1
306 IF ITER>IMAX THEN GOTO 5500
320 GOTO 250
```

130 - Call input
132-136 - Allow user a chance to change input
140 - If new material desired, branch
150 - Calculate invariants
242 - Perform transformations
246 - Find an initial feasible point
250 - New direction
260,300 - Halt conditions, branch to output
290 - New thickness vector
320 - Loop till halt condition

```
505 LET G$="PASS"
510 LET NC=0
520 FOR P=1 TO NPLY
525 IF H(P)=0 THEN GOTO 750
526 LET II=P
527 GOSUB 2400
530 FOR N=1 TO NL
550 LET CON=-1
560 FOR K=1 TO 3
570 FOR J=1 TO 3
580 LET CON=CON+G(K,J)*E(N,J)*E(N,K)
590 NEXT J
600 LET CON=CON+S(K)*E(N,K)
610 NEXT K
630 IF CON>0 THEN LET G$="FAIL"
640 IF CON<-E5 THEN GOTO 700
650 LET NC=NC+1
660 LET C$(NC,1)=CHR$ P
670 LET C$(NC,2)=CHR$ N
700 IF G$="FAIL" THEN RETURN
740 NEXT N
750 NEXT P
760 RETURN
```

CONSTRAINT TEST

525 - If ply thickness zero, ignore constraints associated with it
526-527 - Set up G matrix for ply being tested
560-610 - Solve $con = G_{ij} \epsilon_i \epsilon_j^*$
 $G_{ij} \epsilon_j - 1$
640-670 - If con is close to zero, identify constraint as active. C\$ form a list of constraints in terms of ply and load

```

1010 LET NORM=0
1012 LET II=P
1014 GOSUB 2400
1020 FOR L=1 TO NPLY
1025 IF H(L)=0 THEN GOTO 1200
1026 LET II=L
1027 GOSUB 2200
1030 FOR J=1 TO 3
1040 LET R(J)=0
1045 FOR K=1 TO 3
1050 LET R(J)=R(J)-Q(J,K)*E(N,K)
1060 NEXT K
1070 NEXT J
1080 FOR J=1 TO 3
1090 LET Y(J)=0
1100 FOR K=1 TO 3
1110 LET Y(J)=Y(J)+P(J,K)*R(K)
1120 NEXT K
1130 NEXT J
1150 LET U(L)=0
1155 FOR J=1 TO 3
1160 FOR K=1 TO 3
1170 LET U(L)=U(L)+G(J,K)*(Y(J)*
E(N,K)+E(N,J)*Y(K))
1180 NEXT K
1190 LET U(L)=U(L)+S(J)*Y(J)
1192 NEXT J
1194 LET NORM=NORM+U(L)*U(L)
1200 NEXT L
1210 LET NORM=SOR NORM
1220 FOR L=1 TO NPLY
1250 LET U(L)=U(L)/NORM
1260 NEXT L
1270 RETURN

```

GRADIENT

- 1012-1014 - Form G matrix for designated ply
- 1026-1027 - For each ply, form Q matrix
- 1030-1070 - $\vec{R} = -\frac{\partial}{\partial h} |A| \vec{e}$
- 1080-1130 - $\vec{Y} = |A^{-1}| \vec{R}$
- $\frac{\partial}{\partial h_k} \vec{e}^T = \vec{Y}$
- 1150-1200 - $\vec{\nabla}(\text{CON}) = [G_{ij} (\epsilon_i \frac{\partial \epsilon_j}{\partial h_k} + \frac{\partial \epsilon_i}{\partial h_k} \epsilon_j) + G_i (\frac{\partial \epsilon_i}{\partial h_k})] \hat{h}_k$
- 1210-1260 - Normalize $\vec{\nabla}(\text{CON})$

```

1510 FOR I=1 TO 3
1520 FOR J=I TO 3
1530 LET E(I,J)=A(I,J)+D(I,J)*S
1540 NEXT J
1550 NEXT I
1570 LET DET=E(1,1)*E(2,2)*E(3,3)
+2*E(1,2)*E(2,3)*E(1,3)-E(2,2)*E
(1,3)*E(1,3)-E(1,1)*E(2,3)*E(2,
3)-E(3,3)*E(1,2)*E(1,2)
1580 LET P(1,1)=(E(2,2)*E(3,3)-E
(2,3)*E(2,3))/DET
1590 LET P(2,2)=(E(1,1)*E(3,3)-E
(1,3)*E(1,3))/DET
1600 LET P(1,2)=(E(1,3)*E(2,3)-E
(1,2)*E(3,3))/DET
1610 LET P(3,3)=(E(1,1)*E(2,2)-E
(1,2)*E(1,2))/DET
1620 LET P(1,3)=(E(1,2)*E(2,3)-E
(2,2)*E(1,3))/DET
1630 LET P(2,3)=(E(1,2)*E(1,3)-E
(1,1)*E(2,3))/DET
1640 LET P(2,1)=P(1,2)
1650 LET P(3,2)=P(2,3)
1660 LET P(3,1)=P(1,3)
1680 FOR I=1 TO NL
1690 FOR J=1 TO 3
1700 LET E(I,J)=0
1710 FOR K=1 TO 3
1720 LET E(I,J)=E(I,J)+P(J,K)*N(
I,K)
1730 NEXT K
1740 NEXT J
1750 NEXT I
1760 RETURN

```

FIND STRAINS

- 1510-1550 - |E| is temporarily the A matrix at a point along the Z vector, a distance S from the current position in h space
- 1570-1660 - Invert A
- 1680-1750 - Solve $\vec{\epsilon} = |A^{-1}| \vec{N}$ for each independent loading

```

0020 FOR I=1 TO 3
0030 FOR J=1 TO 3
0040 LET A(I,J)=0
0050 LET D(I,J)=0
0060 NEXT J
0070 NEXT I
0080 FOR I=1 TO NPLY
0090 LET II=I
0095 GOSUB 2200
0100 FOR J=1 TO 3
0110 FOR K=1 TO 3
0120 LET A(J,K)=A(J,K)+0(J,K)*H(
H)
0130 LET D(J,K)=D(J,K)+0(J,K)*Z(
H)
0140 NEXT K
0150 NEXT J
0160 NEXT I
0170 RETURN

```

FORM A_h AND A_z

2120 - A_h is the A matrix at the current position in h space

$$2130 - A_{z,ij} = \sum_{k=1}^{NPLY} Q_{ij}^{(k)} Z_k$$

```

0210 LET Q(1,1)=C(II,1)
0220 LET Q(1,2)=C(II,3)
0230 LET Q(1,3)=C(II,5)
0240 LET Q(2,2)=C(II,2)
0250 LET Q(2,3)=C(II,6)
0260 LET Q(3,1)=C(II,5)
0270 LET Q(3,2)=C(II,6)
0280 LET Q(3,3)=C(II,4)
0290 RETURN
0300
0410 LET G(1,1)=B(II,1)
0420 LET G(1,2)=B(II,3)
0430 LET G(1,3)=B(II,5)
0440 LET G(2,1)=B(II,3)
0450 LET G(2,2)=B(II,2)
0460 LET G(2,3)=B(II,6)
0470 LET G(3,1)=B(II,5)
0480 LET G(3,2)=B(II,6)
0490 LET G(3,3)=B(II,4)
0492 LET S(1)=B(II,7)
0494 LET S(2)=B(II,8)
0496 LET S(3)=B(II,9)
0498 RETURN

```

FORM Q

2210-2290 - Convert C array into 3x3 Q matrix for a ply designated by II

FORM G

2410-2490 - Convert B array into 3x3 G matrix for a ply designated by II
2492-2496 - Place linear terms of G in vector S

NEW POSITION

```

2501 LET SMAX=1E10
2502 FOR I=1 TO NPLY
2503 IF Z(I) <> 0 THEN LET S=-H(I)
      /Z(I)
2504 IF S > 0 AND S < SMAX THEN LET
SMAX=S
2505 NEXT I
2506 LET F$=""
2507 IF SMAX > 10 THEN LET F$="FAI
L"
2510 LET S2=SMAX
2512 IF F$="FAIL" THEN RETURN
2514 LET S1=0
2520 IF NC=0 THEN GOTO 2600
2530 LET S=S2
2540 GOSUB 1500
2550 GOSUB 500
2560 IF G$="FAIL" THEN LET S2=S
2570 IF G$="PASS" THEN LET S1=S
2585 IF S1=SMAX THEN GOTO 2625
2590 LET S=(S1+S2)/2
2600 IF (S2-S1) < E2 AND S1=0 THEN
LET F$="FAIL"
2605 IF F$="FAIL" THEN GOTO 2760
2610 IF S1/(S2-S1) < 4 THEN GOTO 2
540
2620 LET S=S1/2
2625 LET SREF=0
2630 FOR I=1 TO NPLY
2640 LET H(I)=H(I)+Z(I)*S
2650 IF H(I) < E3 THEN LET H(I)=0
2660 LET SREF=SREF+H(I)*H(I)
2670 NEXT I
2680 LET S=0
2690 GOSUB 2000
2700 GOSUB 1500
2710 LET SREF=SQR SREF
2720 GOSUB 3500
2725 IF SREF-S < E2 THEN LET F$="F
AIL"
2730 FOR I=1 TO NPLY
2740 LET H(I)=H(I)*S/SREF
2750 NEXT I
2760 LET S=0
2770 GOSUB 2000
2780 GOSUB 1500
2790 GOSUB 500
2800 RETURN

```

- 2501-2505 - Find distance along Z to first $h_i=0$ constraint
- 2540-2610 - Bisection method to find distance to next constraint
- 2585 - If no constraints are violated at $S = SMAX$ then stop search and use that point
- 2620 - Take a point halfway in between constraints
- 2625-2670 - Update h vector at that point and calculate distance to origin
- 2690-2700 - Update strains at the mid-point
- 2720 - Use strain ratio routine to find nearest constraint along a line from the midpoint to the origin
- 2730-2750 - Update h vector to new point near constraint
- 2770 - Update A matrix
- 2780 - Update strains
- 2790 - List of active constraints

NEW DIRECTION

```

3005 LET NORM=1
3006 LET Z=0
3020 FOR I=1 TO NPLY
3030 LET X(I)=0
3040 LET Z=Z+SGN H(I)
3050 NEXT I
3052 LET Z=1/SQR Z
3060 IF NC=0 THEN GOTO 3225
3070 FOR I=1 TO NC
3072 LET P=CODE C$(I,1)
3074 LET N=CODE C$(I,2)
3080 GOSUB 1000
3140 FOR J=1 TO NPLY
3150 LET X(J)=X(J)-N(J)
3160 NEXT J
3170 NEXT I
3180 LET NORM=0
3190 FOR J=1 TO NPLY
3200 LET NORM=NORM+X(J)*X(J)
3210 NEXT J
3220 LET NORM=SQR NORM
3224 LET TEST=0
3225 FOR I=1 TO NPLY
3226 LET X(I)=X(I)/NORM
3230 LET TEST=TEST+X(I)*Z*SGN H(I)
3240 NEXT I
3250 LET NORM=0
3260 FOR I=1 TO NPLY
3270 LET Z(I)=X(I)-TEST*Z*SGN H(I)
3280 LET NORM=NORM+Z(I)*Z(I)
3290 NEXT I
3292 LET F$=""
3294 IF NORM<1E-6 THEN LET F$="F
AIL"
3296 IF F$="FAIL" THEN RETURN
3300 LET NORM=SQR NORM
3310 FOR I=1 TO NPLY
3320 LET Z(I)=Z(I)/NORM
3330 NEXT I
3340 GOSUB 2000
3350 RETURN

```

- 3020-3052 - Initialize \vec{x} . Z is the square root of the number of non-zero thickness plies
- 3070-3080 - For each active constraint calculate the gradient of the constraint. P and N identify the constraint to the gradient routine
- 3140-3320 - Sum all gradients into \vec{x} and normalize \vec{x}
- 3225-3240 - Test is the dot product of \vec{x} and the unit normal (\vec{h}) to the $\Phi_{hi} = \text{const.}$ plane
- 3260-3290 - \vec{Z} is now a vector parallel to $\Phi_{hi} = \text{const.}$ plane and pointing away from the active constraints
- 3292-3296 - If the magnitude of \vec{Z} is close to zero then $\vec{Z} \parallel \vec{h}$ and a local minima has been reached
- 3310-3330 - normalize \vec{Z}

STRAIN RATIO

```

3510 FOR P=1 TO NPLY
3520 IF H(P)=0 THEN GOTO 3640
3522 LET II=P
3524 GOSUB 2400
3530 FOR N=1 TO NL
3540 LET B=0
3545 LET C=0
3550 FOR I=1 TO 3
3560 FOR J=1 TO 3
3570 LET C=C-SREF*SREF*G(I,J)*E(N,I)*E(N,J)
3580 NEXT J
3590 LET B=B-SREF*S(I)*E(N,I)
3600 NEXT I
3610 LET SVAL=(-B+SQR(B*B-4*C*(1-E6)))/(2*(1-E6))
3620 IF SVAL>S THEN LET S=SVAL
3630 NEXT N
3640 NEXT P
3650 RETURN

```

- 3522-3524 - Form G matrix
- 3522-3610 - For each constraint solve

$$\frac{G_{ij} \epsilon_i \epsilon_j (\text{SREF})^2}{S^2}$$

$$+ \frac{G_i \epsilon_i (\text{SREF})}{S} - 1 = E6$$

for S

- 3620 - Take smallest value of S (closest constraint)

INITIAL FEASIBLE PT.

```

4110 LET Z=1/SQR NPLY
4120 FOR I=1 TO NPLY
4125 LET Z(I)=Z
4130 LET H(I)=Z
4140 NEXT I
4150 GOSUB 2000
4160 LET S=0
4170 LET SREF=1
4180 GOSUB 1500
4185 LET S=0
4190 GOSUB 3500
4330 FOR I=1 TO NPLY
4340 LET H(I)=H(I)*S
4350 NEXT I
4360 LET S=0
4375 GOSUB 2000
4380 GOSUB 1500
4390 GOSUB 500
4400 RETURN

```

4110-4150 - Initialize the h vector to an arbitrary point along the line $h_1=h_2 = h_{NPLY}$

4180 - Establish the strains at that point. Point is far enough out that no constraints are violated for reasonable structures

4190 - Use strain ratios to find nearest constraint

4330-4350 - h vector updated so that position in h space lies on constraint

4375-4390 - Update A matrix and constraint list

```

4510 FOR I=1 TO NPLY
4520 LET C2=COS (2*T(I))
4530 LET C4=COS (4*T(I))
4540 LET S2=SIN (2*T(I))
4550 LET S4=SIN (4*T(I))
4560 LET B(I,1)=U(1)+C2*U(2)+C4*U(3)
4570 LET B(I,2)=U(1)-C2*U(2)+C4*U(3)
4580 LET B(I,3)=U(4)-C4*U(3)
4590 LET B(I,4)=U(5)-C4*U(3)
4600 LET B(I,5)=S2/2*U(2)+S4*U(3)
4610 LET B(I,6)=S2/2*U(2)-S4*U(3)
4650 LET B(I,7)=U(6)+C2*U(7)
4660 LET B(I,8)=U(6)-C2*U(7)
4670 LET B(I,9)=S2*U(7)
4680 LET C(I,1)=U(1)+C2*U(2)+C4*U(3)
4690 LET C(I,2)=U(1)-C2*U(2)+C4*U(3)
4700 LET C(I,3)=U(4)-C4*U(3)
4710 LET C(I,4)=U(5)-C4*U(3)
4720 LET C(I,5)=S2/2*U(2)+S4*U(3)
4730 LET C(I,6)=S2/2*U(2)-S4*U(3)
4770 NEXT I
4780 RETURN

```

TRANSFORMATIONS

4560-4670 - Transform failure parameters in following order

$B(I,1)=G_{11}$	$B(I,5)=G_{16}$
$B(I,2)=G_{22}$	$B(I,6)=G_{26}$
$B(I,3)=G_{12}$	$B(I,7)=G_7$
$B(I,4)=G_{66}$	$B(I,8)=G_2$
	$B(I,9)=G_3$

4680-4730 - Transform modulus in following order

$C(I,1)=Q_{11}$	$C(I,4)=Q_{66}$
$C(I,2)=Q_{22}$	$C(I,5)=Q_{16}$
$C(I,3)=Q_{12}$	$C(I,6)=Q_{26}$

Note, transformations for all orientations calculated and stored

INPUT

```
5090 CLS
5091 FAST
5092 FOR I=1 TO 6
5093 PRINT I,") ",M$(I)
5094 NEXT I
5095 PRINT "7) NEW"
5096 SLOW
5097 PRINT AT 15,5,"SELECT MATER
5098
5099 INPUT M
5100 CLS
5101 PRINT "HOW MANY PLY ANGLES?
5210 INPUT NPLY
5211 CLS
5212 PRINT "ENTER PLY ORIENTATIO
5213 (DEGREES)"
5214 FOR I=1 TO NPLY
5215 PRINT "PLY ",I,"="
5216 INPUT T(I)
5217 PRINT AT I,7;T(I)
5218 LET T(I)=T(I)*PI/180
5219 NEXT I
5220 PAUSE 120
5221 CLS
5222 PRINT "ENTER NUMBER OF INDE
5223 PENDANT "LOADING CONDITIONS"
5224 INPUT NL
5225 LET U$=" N/M"
5226 LET U$=" M"
5227 PRINT "ENGLISH OR SI UNITS?
5228 (E/S)"
5229 INPUT E$
5230 IF E$="E" THEN LET U$=" LBS
5231 IN"
5232 IF E$="S" THEN LET U$=" IN"
5233 FOR I=1 TO NL
5234 CLS
5235 PRINT "LOADING CONDITION "
5236 I
5237 FOR J=1 TO 3
5238 LET L=J
5239 IF J=3 THEN LET L=6
5240 PRINT "N";L;"="
5241 INPUT N(I,J)
5242 PRINT AT J,4;N(I,J);U$
5243 IF E$="E" THEN LET N(I,J)=N
5244 (I,J)*511
5245 NEXT J
5246 PAUSE 120
5247 NEXT I
5248 CLS
5249 FAST
5250 RETURN
```

5090-5160 - List available materials

5210 - NPLY = number of layers

5230-5290 - Enter orientations
computer requires angles
in radians, so convert
degrees to radians

5330-5428 - Establish proper units
labels

5450-5480 - Enter loads. If loads
are in lbs/in, convert
to N/m

OUTPUT

```
5505 LET TEST=0
5506 LET E=1
5510 FOR I=1 TO NPLY
5520 LET TEST=TEST+H(I)
5530 NEXT I
5535 IF E$="E" THEN LET E=SI2
5539 CLS
5540 PRINT "TOTAL LAMINATE THICK
NESS"
5544 PRINT TAB 10;TEST*E;U$
5549 PRINT
5550 PRINT NC;" ACTIVE CONSTRAIN
TS "
5555 PRINT "AFTER ";ITER;" ITERA
TIONS"
5560 PRINT AT 21,0;K$
5570 PAUSE 40000
5575 CLS
5585 GOSUB 5570
5590 PRINT AT 21,0;K$
5600 PAUSE 40000
5605 CLS
5615 GOSUB 5560
5620 PRINT AT 21,0;K$
5630 PAUSE 40000
5635 CLS
5640 PRINT "HARDCOPY (Y/N)?"
5645 INPUT H$
5650 IF H$="Y" THEN GOSUB 5500
5655 CLS
5660 PRINT "HISTOGRAM (Y/N)?"
5665 INPUT A$
5670 IF A$="Y" THEN GOSUB 7500
5675 GOTO 1
```

5510-5535 - Sum for total thickness and establish units conversion

5615 - Call ply ratio printout

5626 - Call strength ratio printout

```
5660 PRINT "STRENGTH RATIOS "
5665 PRINT "1=ULTIMATE STRAIN: >
1=SAFE"
5670 PRINT "PLY"
5672 FOR I=1 TO NL
5674 PRINT AT 2,I*7-1;"LOAD"; I
5676 NEXT I
5680 FOR P=1 TO NPLY
5685 IF H(P)=0 THEN GOTO 5810
5690 LET II=P
5695 GOSUB 2400
5700 FOR N=1 TO NL
5702 LET A=0
5704 LET B=0
5710 FOR J=1 TO 3
5720 FOR K=1 TO 3
5730 LET A=A+G(J,K)*E(N,J)*E(N,K)
5740 NEXT K
5750 LET B=B+S(J)*E(N,J)
5760 NEXT J
5770 LET A=(-B+50R (B*B+4*A))/(2*A)
5780 LET A=INT ((A+.5/1E3)*1E3)/1E3
5785 PRINT AT P+2,N*7-1;A
5790 NEXT N
5800 PRINT AT P+2,0;U(P)
5810 NEXT P
5820 RETURN
```

STRENGTH RATIOS

5700-5780 - Solve for R in

$$[G_{ij} \epsilon_i^N \epsilon_j^N] R^2 + [G_i \epsilon_i^N] R - 1 = 0$$

for each loading

```

3880 PRINT "ANGLE";TAB 11;"RATIO
";TAB 21;"NO. PLIES"
3890 FOR I=1 TO NPLY
3900 LET U(I)=INT ((T(I)*180/PI+
.05)*10)/10
3910 LET A=INT ((H(I)/TEST+.5/1E
4)*1E4)/1E4
3920 LET B=INT ((H(I)/TPLY+.005)
*100)/100
3930 PRINT U(I);TAB 11;A;TAB 24;
$
3940 NEXT I
3950 RETURN

```

PLY RATIO

For each orientation, find ply
NPLY
ratio = $(h_i / \sum_{i=1} h_i)$ and number of

plies = $h_i / (\text{ply thickness})$

```

5510 LPRINT "*****"
*****"
5520 LPRINT "MATERIAL ";M$(M)
5525 LET A$=STR$(TEST*E)+U$
5530 LPRINT "TOTAL THICKNESS ";A
$
5540 LPRINT "AFTER ";ITER;" ITER
ATIONS"
5550 FOR I=1 TO NL
5570 LPRINT
5572 LET L=1
5574 IF E$="E" THEN LET L=1/SI1
5580 FOR J=1 TO 3
5582 LET A=J
5586 IF A=3 THEN LET A=6
5590 LPRINT "N";A;"=" ";N(I,J)*L;
J$
5600 NEXT J
5610 NEXT I
5620 LPRINT
5625 CLS
5630 GOSUB 5670
5640 COPY
5645 CLS
5650 GOSUB 5660
5660 COPY
5670 RETURN

```

HARDCOPY

5560-5610 - Print loads with
given units

5630 - Call ply ratio

5650 - Call strength ratio

```

7005 SLOW
7006 CLS
7007 LET M=6
7010 PRINT "ENTER ENGINEERING CO
NSTANTS"
7015 PRINT "IN GPA."
7020 FOR I=1 TO 4
7030 PRINT AT I+1,0;R$(I);"=" ?"
7040 INPUT A
7050 PRINT AT I+1,4;A
7060 LET P$(6,I*5-4 TO I*5-1)=ST
R$ A
7070 NEXT I
7080 CLS
7090 PRINT "ENTER STRENGTHS IN M
PA."
7100 FOR I=1 TO 5
7110 PRINT AT I+2,0;S$(I);"=" ?"
7120 INPUT A
7130 PRINT AT I+2,10;A
7150 LET Y$(6,I*5-4 TO I*5-1)=ST
R$ A
7160 NEXT I
7170 CLS
7180 PRINT "ENTER MATERIAL NAME
(15 CHARC.)"
7190 INPUT M$(6)
7195 FAST
7200 RETURN

```

NEW MATERIAL

7030 - R\$ contains prompts E_x ,
 E_y , V_x , G

7060 - String concatenation to
store properties in P\$
array

7110 - S\$ contains prompts X(TENS.),
X(COMP.), Y(TENS.), Y(COMP.),
SHEAR

7150 - String concatenation to store
strengths in Y\$ array

HISTOGRAM

```
7500 LET Z=0
7502 CLS
7505 FOR I=1 TO NPLY
7510 IF H(I)/TEST>Z THEN LET Z=H
(I)/TEST
7520 NEXT I
7522 LET DELTA=INT (Z/9*100+1)/1
00
7525 FOR I=1 TO NPLY
7530 LET Z(I)=INT (H(I)*4.2/TEST
/DELTA+.5)
7540 NEXT I
7550 FOR I=1 TO NPLY
7560 FOR J=3 TO Z(I)+2
7570 FOR K=-1 TO 1
7580 PLOT INT (U(I)*3/10+35.5)+K
J
7590 NEXT K
7600 NEXT J
7610 NEXT I
7620 FOR I=1 TO 7
7625 LET J=INT (I*4.5+.5)-2
7626 IF J=16 THEN LET J=J+1
7630 PRINT AT 21,J;-120+I*30
7640 NEXT I
7660 LET Z=11*DELTA
7670 FOR I=0 TO 18 STEP 2
7680 LET Z=Z-DELTA
7690 LET A=INT ((Z+.005)*1E2)/1E
2
7700 PRINT AT I,0;A
7710 NEXT I
7720 IF H<>"Y" THEN PAUSE 40000
7730 IF H="Y" THEN COPY
7740 RETURN
```

7505-7520 - Find largest h_i

7522 - Vertical scale increment

7530 - Bar height in terms of pixels

7580 - Plot bars, 3 pixels wide

7620-7640 - Horizontal scale

7660-7710 - Vertical scale

INVARIANTS

```

3160 LET EX=VAL P$(M,1 TO 4)*1E9
3170 LET EY=VAL P$(M,6 TO 9)*1E9
3180 LET UX=VAL P$(M,11 TO 14)
3190 LET ES=VAL P$(M,16 TO )*1E9
3200 LET XT=VAL Y$(M,1 TO 4)*1E6
3210 LET XC=VAL Y$(M,6 TO 9)*1E6
3220 LET YT=VAL Y$(M,11 TO 14)*1
3230 LET YC=VAL Y$(M,16 TO 19)*1
3240 LET SS=VAL Y$(M,21 TO )*1E6
3250 LET N=1/(1-UX*UX+EY/EX)
3260 LET OXX=N*EX
3270 LET OYY=N*EY
3280 LET OXY=N*UX*EY
3290 LET OS=ES
3300 LET U(1)=(3*OXX+3*OYY+2*OXY
+4*OS)/8
3310 LET U(2)=(OXX-OYY)/2
3320 LET U(3)=(OXX+OYY-2*OXY-4*E
S)/8
3330 LET U(4)=(OXX+OYY+6*OXY-4*E
S)/8
3340 LET U(5)=(OXX+OYY-2*OXY+4*E
S)/8
3350 LET EX=1/(XT*XC)
3360 LET EY=1/(YT*YC)
3370 LET ES=1/(SS*SS)
3380 LET FX=1/XT-1/XC
3390 LET FY=1/YT-1/YC
3400 LET EXY=-SQR (EX*EY)/2
3410 LET GXX=EX*OXX*OXX+2*EXY*OXY
+OXY*EY*OXY*OXY
3420 LET GYY=EX*OXY*OXY+2*EXY*OXY
Y*OYY+EY*OYY*OYY
3430 LET GXY=EX*OXX*OXY+EXY*(OXX
*OYY+OXY*OXY)+EY*OXY*OYY
3440 LET GSS=ES*OS*OS
3450 LET GX=FX*OXX+FY*OXY
3460 LET GY=FX*OXY+FY*OYY
3470 LET V(1)=(3*GXX+3*GYY+2*GXY
+4*GSS)/8
3480 LET V(2)=(GXX-GYY)/2
3490 LET V(3)=(GXX+GYY-2*GXY-4*G
SS)/8
3500 LET V(4)=(GXX+GYY+6*GXY-4*G
SS)/8
3510 LET V(5)=(GXX+GYY-2*GXY+4*G
SS)/8
3520 LET V(6)=(GX+GY)/2
3530 LET V(7)=(GX-GY)/2
3540 RETURN

```

8160-8240 - Extract material properties from string arrays VAL converts string to floating point number

8540-8580 - modulus invariants

8590-8620 - Definitions of quadratic strength parameters. Note reuse of variables EX, ET, etc.

8630-8680 - Convert from stress space parameter to strain space

8690-8750 - Failure parameter invariants

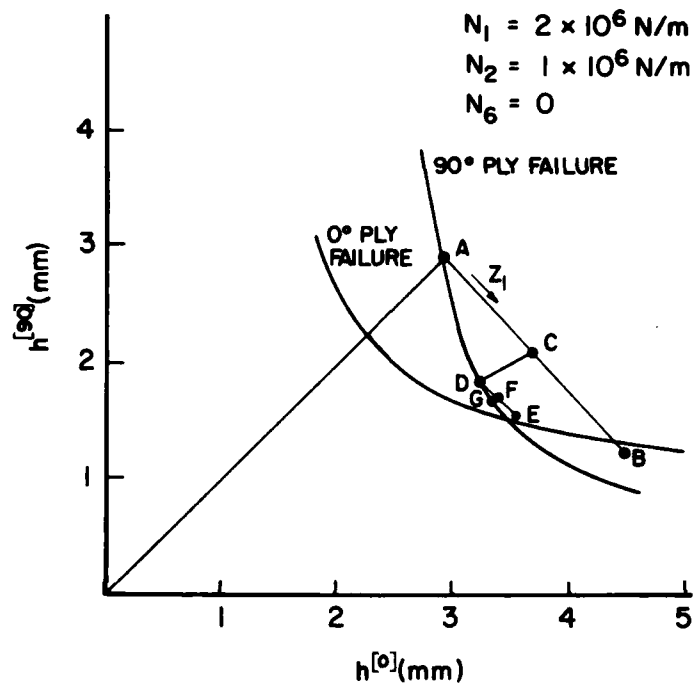

Figure 1. Optimization Trajectory for [0/90] Laminate.

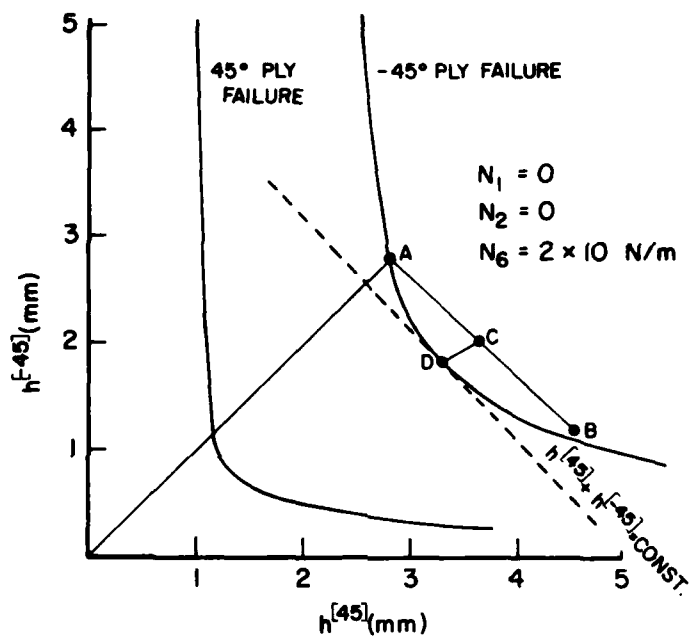

Figure 2. Optimization Trajectory for $[\pm 45]$ Laminate.

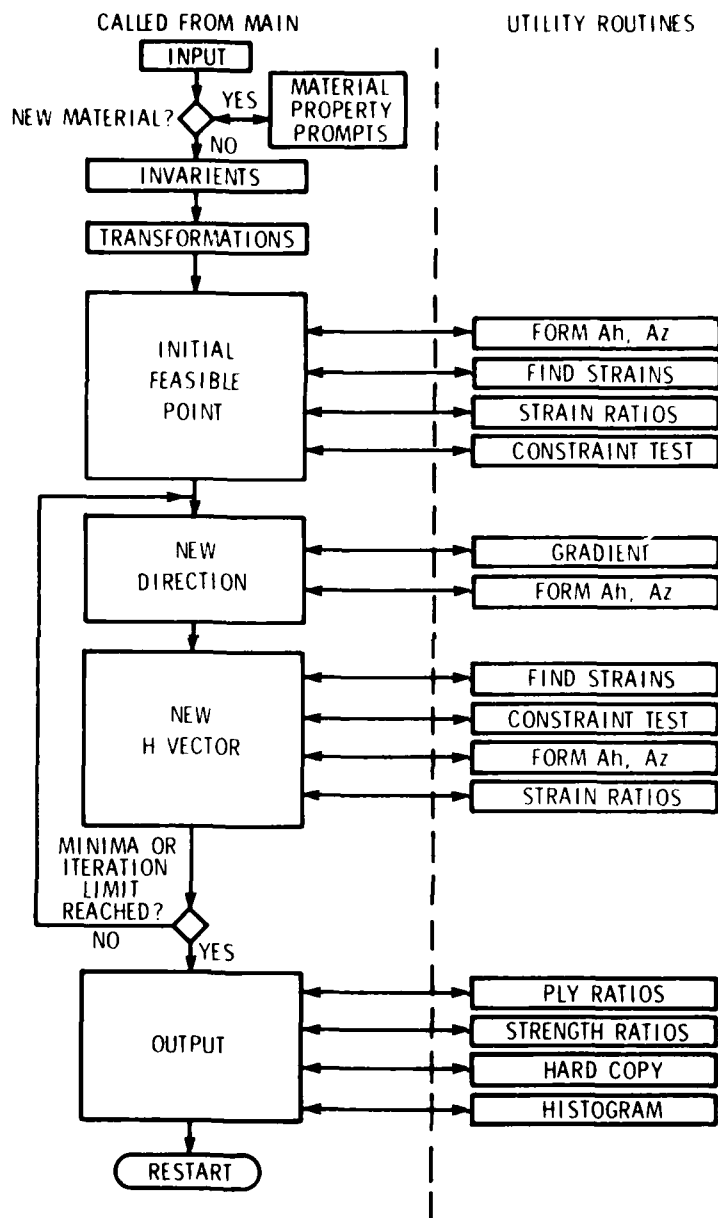

Figure 3. Flow Chart

**LATE
LME**