

MICROCOPY RESOLUTION TEST CHART
NATIONAL BUREAU OF STANDARDS-1963-A

1
①

PHYSICAL MODELING TECHNIQUES FOR MISSILE
AND OTHER
PROTECTIVE STRUCTURES

Papers Submitted for Presentation During the
American Society of Civil Engineers
National Spring Convention
Las Vegas, April 1982

Sponsored By the ASCE Engineering Mechanics Division
Committee on Experimental Analysis and Instrumentation

Edited By: T. Krauthammer and C. D. Sutton

01133

DTIC FILE COPY

SELECTED
JUL 14 1983
S A

This document has been approved
for public release and sale; its
distribution is unlimited.

83

OK OK

109



DEPARTMENT OF THE AIR FORCE
HEADQUARTERS BALLISTIC MISSILE OFFICE (AFSC)
NORTON AIR FORCE BASE, CALIFORNIA 92409

TO PA

29 Jun 83

BT Review of Material for Public Release

TO Mr. James Shafer
Defense Technical Information Center
DDAC
Cameron Station
Alexandria, VA 22314

The following technical papers have been reviewed by our office and are approved for public release. This headquarters has no objection to their public release and authorizes publication.

1. (BMO 81-296) "Protective Vertical Shelters" by Ian Narain, A.M. ASCE, Jerry Stepheno, A.M. ASCE, and Gary Landon, A.M. ASCE.
2. (BMO 82-020) "Dynamic Cylinder Test Program" by Jerry Stephens, A.M. ASCE.
3. (AFCMD/82-018) "Blast and Shock Field Test Management" by Michael Noble.
4. (AFCMD/82-014) "A Comparison of Nuclear Simulation Techniques on Generic MX Structures" by John Betz.
5. (AFCMD/82-013) "Finite Element Dynamic Analysis of the DCT-2 Models" by Barry Bingham.
6. (AFCMD/82-017) "MX Basing Development Derived From H. E. Testing" by Donald Cole.
7. (BMO 82-017) "Testing of Reduced-Scale Concrete MX-Shelters-Experimental Program" by J. I. Daniel and D. M. Schultz.
8. (BMO 82-017) "Testing of Reduced-Scale Concrete MX-Shelters-Specimen Construction" by A. T. Ciolko.
9. (BMO 82-017) "Testing of Reduced-Scale Concrete MX-Shelters-Instrumentation and Load Control" by N. W. Hanson and J. T. Julien.
10. (BMO 82-003) "Laboratory Investigation of Expansion, Venting, and Shock Attenuation in the MX Trench" by J. K. Gran, J. R. Bruce, and J. D. Colton.

11. (BMO 82-003) "Small-Scale Tests of MX Vertical Shelter Structures" by J. K. Gran, J. R. Bruce, and J. D. Colton.

12. (BMO 82-001) "Determination of Soil Properties Through Ground Motion Analysis" by John Frye and Norman Lipner.

13. (BMO 82-062) "Instrumentation for Protective Structures Testing" by Joe Quintana.

14. (BMO 82-105) "1/5 Size VHS Series Blast and Shock Simulations" by Michael Noble.

15. (BMO 82-126) "The Use of Physical Models in Development of the MX Protective Shelter" by Eugene Sevin.

*16. REJECTED: (BMO 82-029) "Survey of Experimental Work on the Dynamic Behavior of Concrete Structures in the USSR" by Leonid Millstein and Gajanen Sabnis.

CAROL A. SCHALKHAM, 1LT, USAF
Public Affairs Officer

Cy To: Dr. T. Krauthammer
Associate Professor
Department of Civil and
Mineral Engineering
University of Minnesota

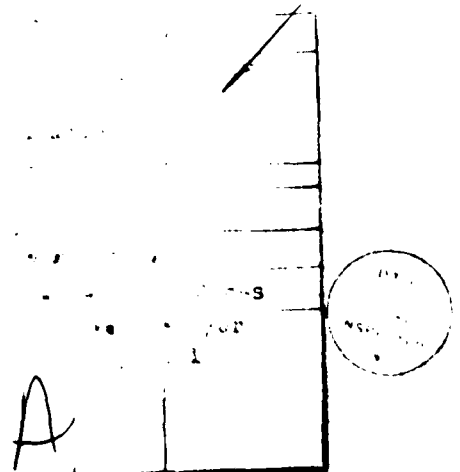

MX BASING DEVELOPMENT DERIVED

FROM H.E. TESTING

Donald M. Cole

ABSTRACT

The large size testing associated with the buried trench, horizontal and vertical shelter basing concepts is evaluated for its role in the development of structural design concepts. The major impact of the testing was in general to revise baseline concepts and to develop confident design and analysis procedures.

KEY WORDS: MX, BASING TECHNOLOGY, STRUCTURAL RESPONSE BLAST AND SHOCK TESTING, REINFORCED CONCRETE, SOIL-STRUCTURE INTERACTION

MX BASING DESIGN DEVELOPMENT DERIVED FROM H.E. TESTING^a

By Donald M. Cole¹, M. ASCE

INTRODUCTION

From the early 1970's to the present the Air Force assisted by the Defense Nuclear Agency has conducted an intense study of the suitability of protective basing concepts for the MX missile (and required support equipment) for conditions of nuclear attack. This paper will concentrate on large size, high explosive field testing, which was only one aspect of the overall Nuclear Hardness and Survivability Program that supported the development of an MX Weapon System. After a brief presentation of background information, the large size field testing associated with the first-three of four basing concepts will be analyzed to determine if fundamental assumptions for structural loading and response were confirmed or altered. These fundamental assumptions become critical when they define the design requirements for the protective structural concept. The first basing concept will be treated in detail and the remaining concepts summarized.

^aPresented at the April 1981, ASCE National Convention held at Las Vegas, Nevada.

¹Research Structural Engineer, Civil Engineering Research Division, Air Force Weapons Laboratory, Kirtland Air Force Base, New Mexico.

/

In many cases, the large scale testing and associated analysis influenced requirements for supplemental research. Where appropriate, the interaction of the large size testing and the supplemental research will be discussed.

BACKGROUND

Until October 1981, the Air Force concentrated MX basing studies on concepts relying on dispersion and deception in addition to hardening to provide survivability for the weapons system under conditions of nuclear attack. This strategy included considerations of current and projected Soviet capabilities, long range United States goals for Strategic Arms Limitations and the United States defense policy of maintaining a survivable "Triad" structure of nuclear strategic forces. For greater detail on the complex issues affecting this strategy, references 2, 27, 28 and 29 are recommended as a starting point.

The chronology of basing concepts and associated large size testing is given in figure 1. Initially the continuously hardened buried trench concept was selected from the many concepts considered by the Air Force for intensive analytical and experimental study. Recognizing that the trench concept contained substantial technical risk, a system of discrete horizontally aligned shelters connected by a surface road network was chosen as a back-up basing mode. Large size field testing on structural elements of both basing concepts began in April 1977 and continued to October 1978. The change to a vertical shelter concept in 1978 resulted largely from considerations of survivability, economy and from public interface issues associated with land

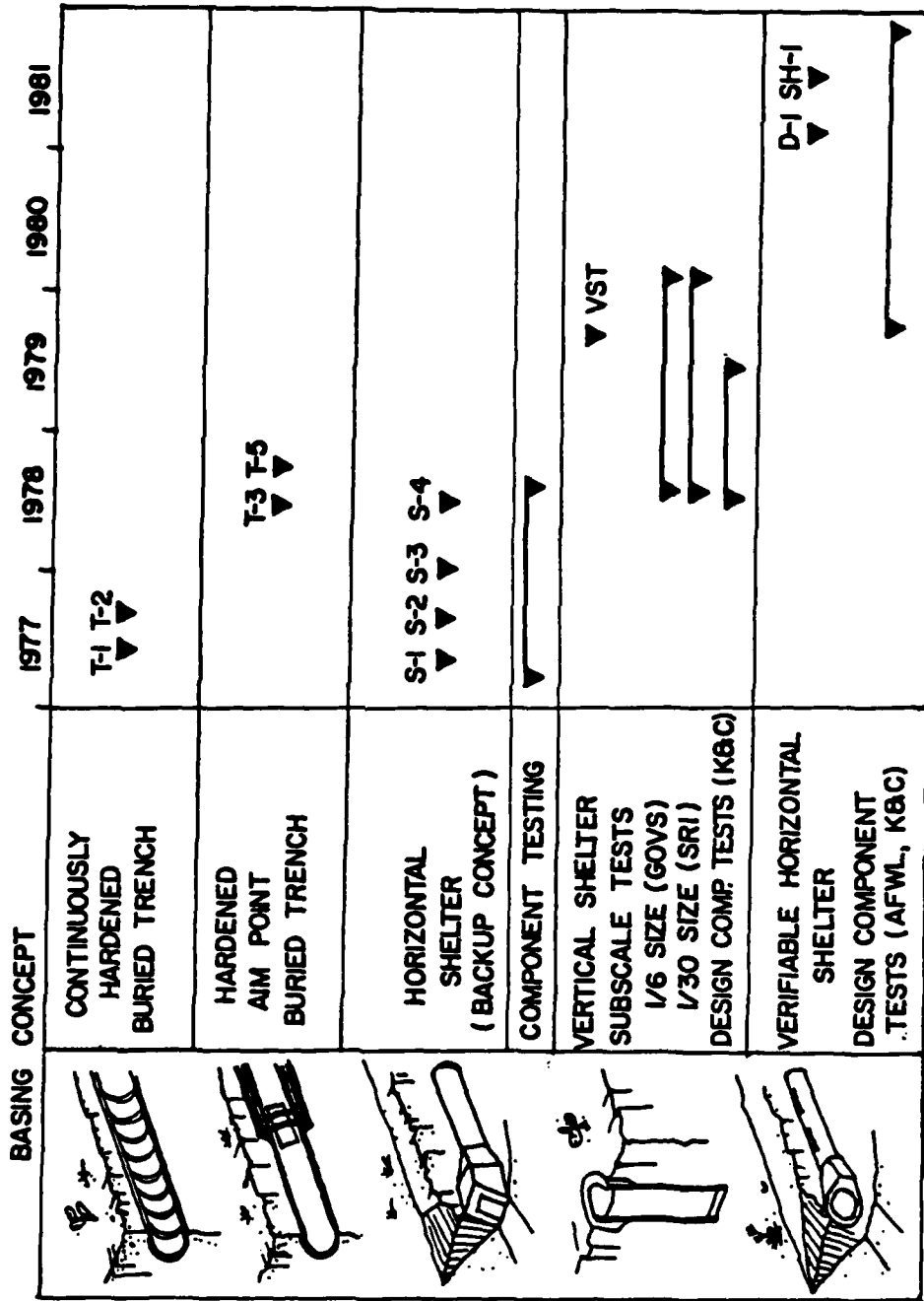

FIGURE 1. BASING CONCEPT & TEST CHRONOLOGY

withdrawal. The change to a verifiable horizontal shelter concept in late 1979 reflected increased emphasis on SAL negotiations.

While this paper will focus on the technical issues associated with design and analysis of the protective structures, it is important to remember the dominant influence that international politics, public policy and opinion and economic considerations have on the design of ~~a basing concept~~.
^{MAY} ~~a basing concept~~ ^{ANY MAJOR EMERGENCY PROTECT.}

BURIED TRENCH BASING CONCEPTS

As initially conceived, the buried trench was actually a set of shallow concrete tunnels each approximately twenty miles long and each containing a single mobile missile protected by a blast plug both fore and aft (figure 2). This train of vehicles would change location frequently so that the entire tunnel length would have to be targeted with weapons to assure destruction of the missile. The number of tunnels and tunnel length were determined based on estimates of the number of warheads available to an attacker. The tunnels were planned to run roughly parallel to each other along the valleys selected for basing, and were not interconnected. The lateral spacing between tunnels (S_t) was selected based on nuclear weapons effects considerations so that no single weapon could significantly damage more than one tunnel. Following an attack, a surviving launcher would erect the missile cannister by breaking out through the roof of the tunnel and pushing through the soil overburden; and would then launch the missile.

Since thousands of miles of tunnel construction would be required, use of highly automated construction techniques had to be anticipated in the design of

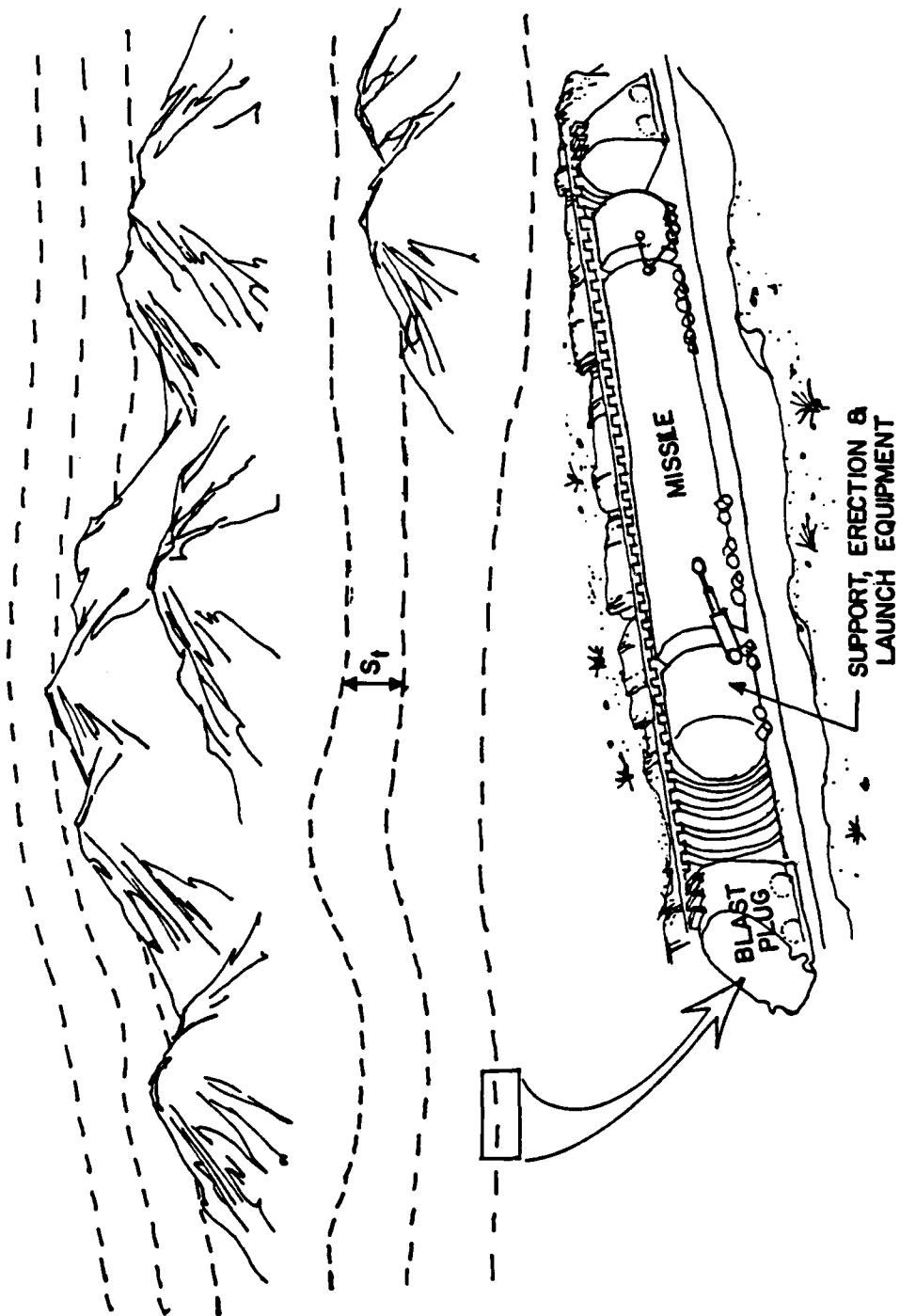

FIGURE 2. BURIED TRENCH BASING CONCEPT

the tunnel structure. This requirement coupled with direction to minimize construction costs, led to a baseline structural concept with constant wall thickness and rib dimensions and using fiber rather than conventional reinforcing for rapid automated construction. This initial baseline configuration is shown in figure 3.

At the beginning of the validation study on the buried trench concept, a number of issues were identified as significant to the adequacy of the concept. These are listed in Table 1. The large size testing discussed in this paper primarily addresses structural loading and response issues. The impact of this testing and associated experimental and analytical efforts was principally to force changes in the conceptual design.

The first two large size test (T-1, T-2, figure 1) were designed to provide very fundamental information on loading and response assumptions used in the concept definition process. Designs for the test articles were derived from the baseline configuration of figure 3. Since model mechanical blast plugs were not yet developed, simple concrete masses were used to examine the fundamental behavior of trench-plug interaction.

Under envisioned attack conditions, breaching of the shallow tunnel structure was thought to be a likely event. This would occur if the crater formed by the attacking weapon intersected the trench structure. When this occurred, radioactive plasma would enter the trench and generate a shock running through the tunnel structure. The amount of energy that would be injected or coupled into the trench was unknown and analytical estimates varied substantially. Similarly, quantitative estimates of the attenuation of this flow could not be confidently estimated without substantial experimental data. The Defense Nuclear Agency (DNA) undertook the task of providing an analytical and experimental program to define the coupling and attenuation

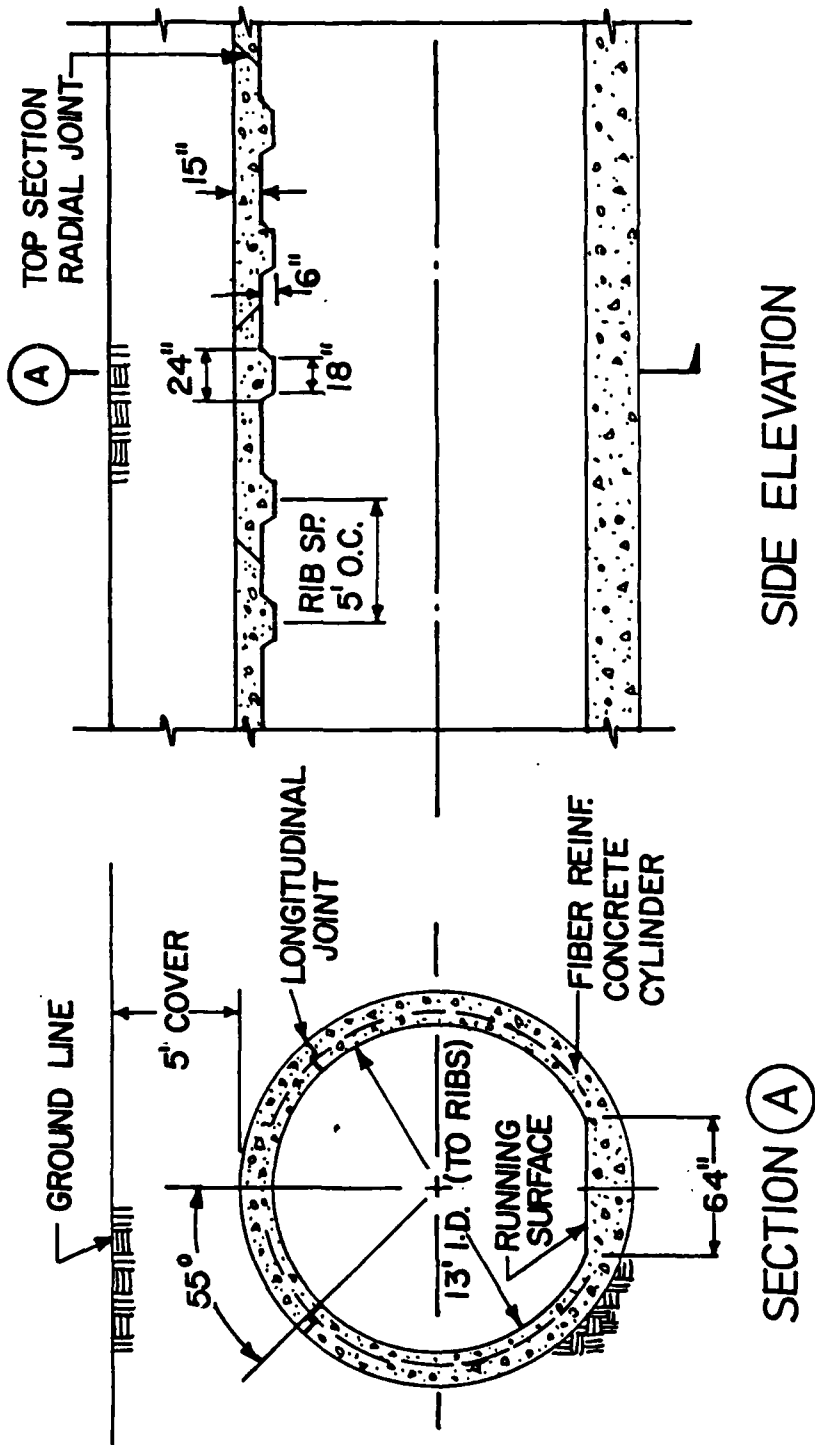

FIGURE 3. BASELINE TRENCH CONFIGURATION

TABLE 1

BURIED TRENCH BASING CONCEPT ISSUES

<u>NUCLEAR ENVIRONMENT ISSUES</u>	<u>OTHER ISSUES</u>
● DIRECT ENERGY COUPLING (PLASMA PENETRATION INTO TRENCH)	● DETECTION (EMISSION CONTROL, DECOY REQUIREMENTS)
● SHOCK AND FLOW ATTENUATION WITHIN TRENCH	● LAND WITHDRAWAL
● CRATER PROJECTILES & DEBRIS	▲ AREA VS POINT SECURITY POLICY (PUBLIC ACCESS)
	▲ PUBLIC VS PRIVATE LAND
	▲ ENVIRONMENTAL IMPACT
<u>STRUCTURAL LOADING & RESPONSE ISSUES</u>	● SALT NEGOTIATIONS
● EXTERNAL LOADING & RESPONSE	▲ FUTURE THREAT
▲ NORMAL & SHEAR SURFACE LOADING (STRUCTURE-MEDIA INTERACTION)	▲ VERIFICATION REQUIREMENTS
▲ TRANSVERSE LOAD CAPACITY	● COST - SURVIVABILITY TRADEOFFS
▲ DAMAGE/DEFORMATION PREDICTIVE CAPABILITY	
● INTERNAL LOADING & RESPONSE	
▲ TRENCH-PLUG INTERACTION (PLUG INDUCED LOADS, STRUCTURE AXIAL CAPACITY, RIB SHEAR CAPACITY)	
▲ EXPANSION UNDER INTERNAL PRESSURE	
▲ BREAKOUT RESPONSE	

1

processes. In the absence of a well defined shock environment within the trench, the first large field test (T-1) was designed to develop structural loading and response data for a known internal shock environment. In addition, analytical techniques for predicting loading and response were evaluated and revised for use as results from the DNA internal environment definition program became available.

The half-sized T-1 test is described in figure 4. The test model closely resembles the baseline shown in figure 3 with some notable exceptions. First, the model was precast in 6 meter long sections and joined on the test site with a form of bell and spigot joint. This procedure was chosen over the automated cast in place construction envisioned in the baseline to reduce modeling costs and to improve quality control for construction and placement of instrumentation. Unfortunately, the presence of this joint did influence both loading and response and was redesigned for later testing. Other exceptions included elimination of the running surface and alteration of the details of the upper 110° of the cylinder (a series of interlocking panels to facilitate breakout of the missile after attack). The design of an economical structure which would resist external nuclear environments and provide for easy breakout of the missile post attack was not entirely a straightforward problem and other approaches would be proposed and tested during concept development.

The major contribution of T-1 was to provide data on the response of the trench structure near the plug. At the face of the plug, the shock flow is abruptly halted resulting in very large reflected pressures. These large pressures, in turn, rapidly accelerate the expansion of the tunnel. Understanding this expansion response was important for two reasons. First,

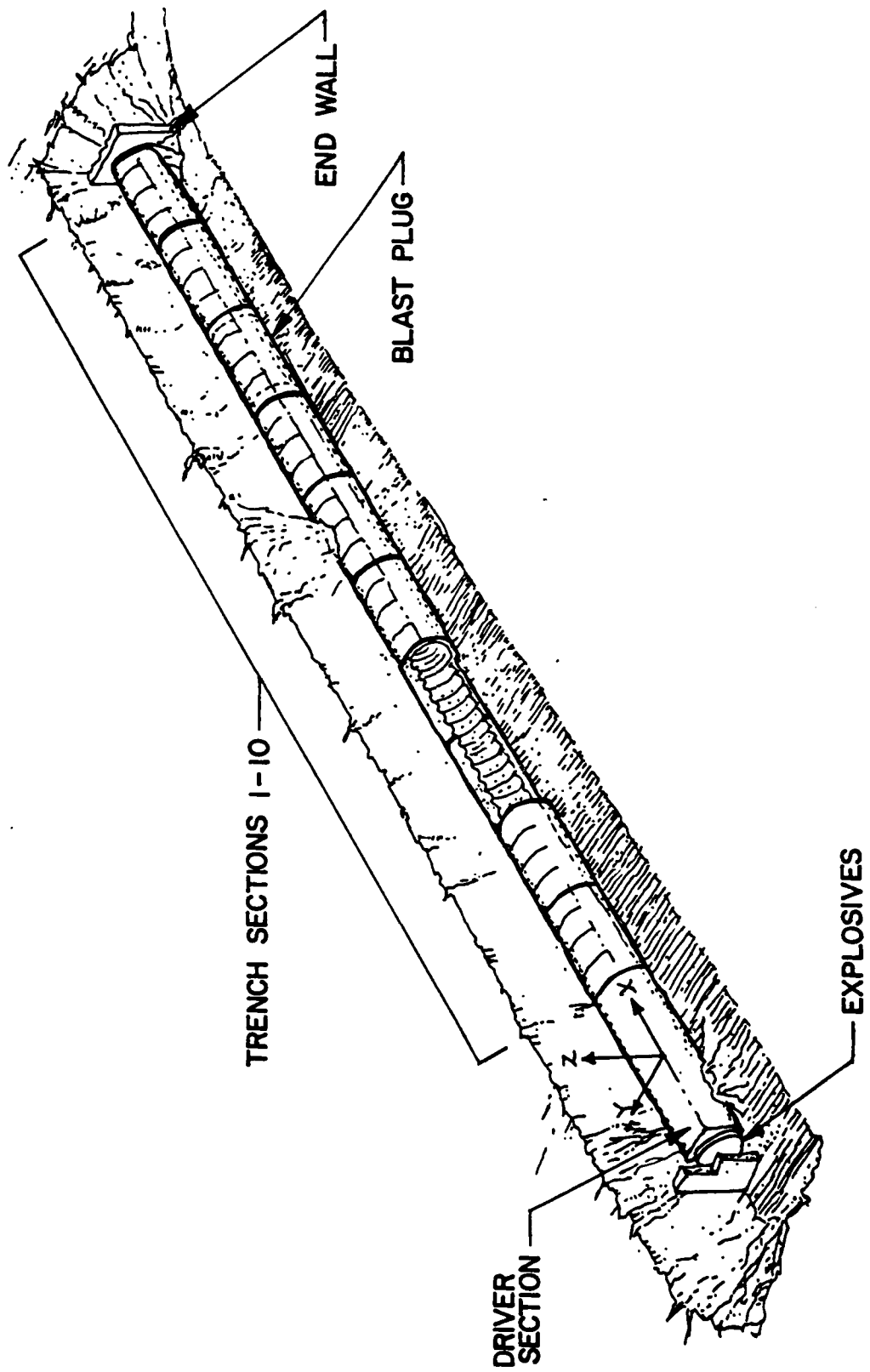
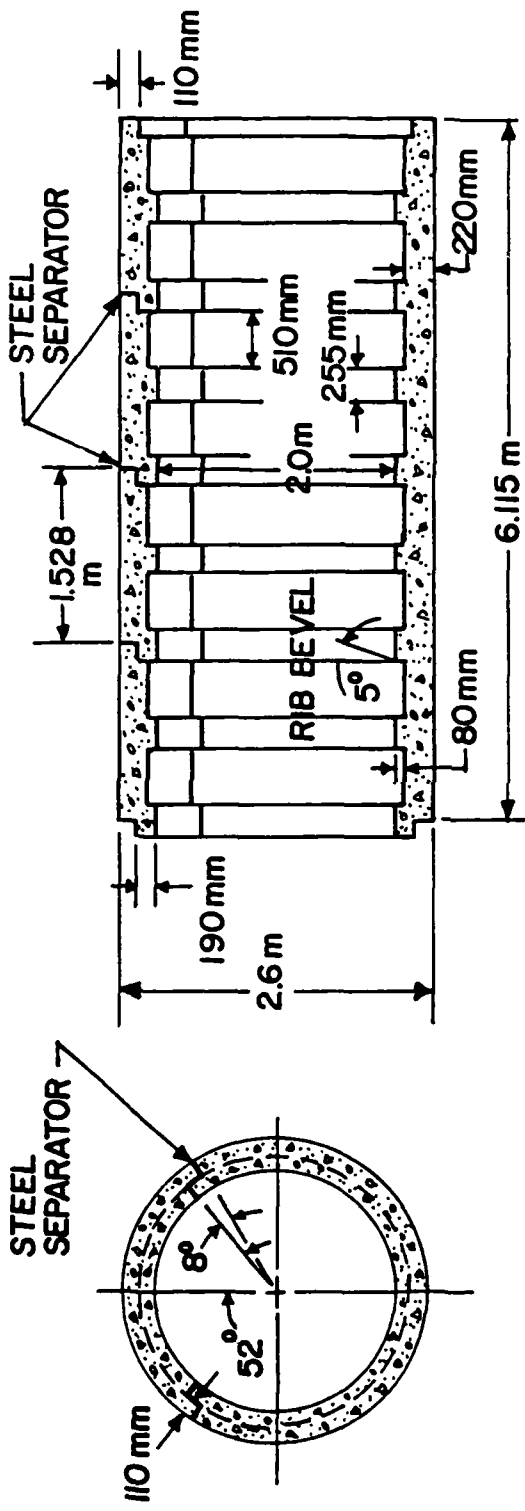

FIGURE 4a. HIGH EXPLOSIVE TEST T-1



SECTION

ELEVATION

- $\ell = 2\%$ FIBER
- $f'_c = 6000$ psi (41 MPa)
- Z TYPE LONGITUDINAL & TRANSVERSE ROOF JOINTS
- BELL/SPIGOT JOINT BETWEEN TRENCH SECTIONS

FIGURE 4b. TYPICAL TRENCH MODEL SECTION

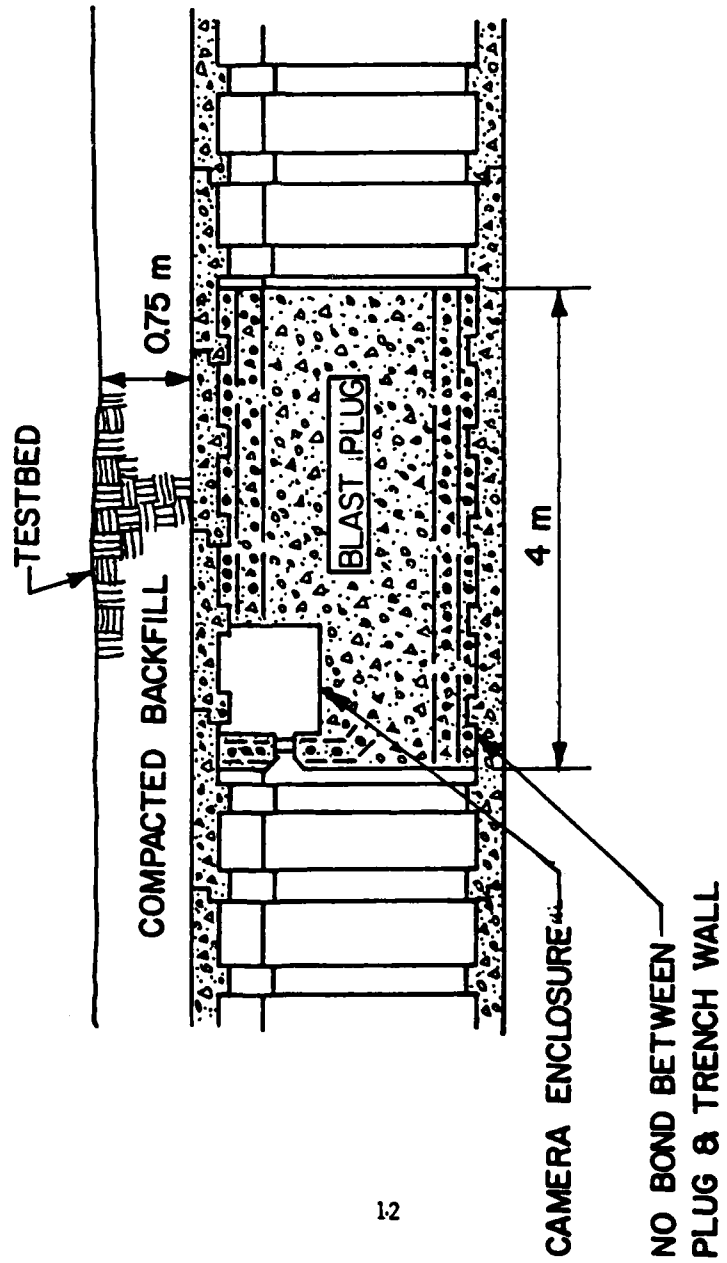
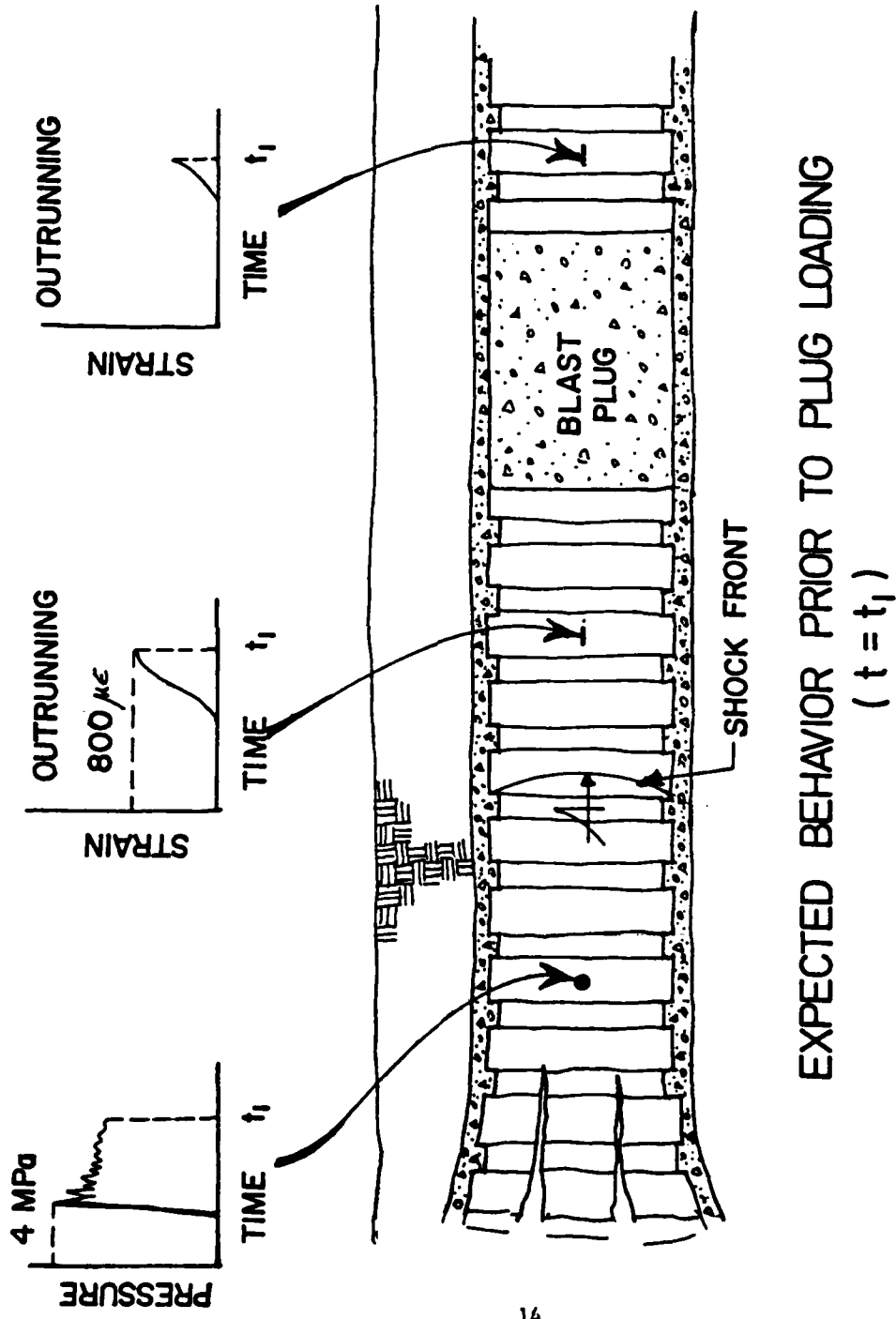

FIGURE 4c. T-1 GENERIC BLAST PLUG

the duration of the high reflected pressure was significantly influenced by both the rate of expansion and the subsequent time required to expand to the point where the gas trapped in the trench could vent to the outside. This process determined the form of the pressure time history on the face of the plug and the resulting axial loading transferred by the plug to the wall of the trench structure behind the plug (figure 5). The second important consideration was the behavior of the trench wall at the rib engagement location of the plug. Circumferential shear failure in the wall would limit the expansion of the wall around the plug and prevent disengagement of the plug. Otherwise, the shock could penetrate around the plug and destroy the missile, and the plug itself would be propelled toward the missile launcher.

Test data confirmed the general predictive capability for shock loading on the plug and expansion of the trench given an incident shock environment. In addition, failure of the trench wall behind the plug did occur as predicted due to loads coupled into the wall from the plug. However, the transverse bell and spigot joint behind the plug appeared on post-test examination to have played a role in the wall failure and this joint was not modeled explicitly in the pretest one-dimensional finite element analysis. Small scale static model tests (reference 10) conducted just prior to T-1 demonstrated wall failure in the absence of transverse joints at loading well below the peak dynamic loads of T-1. Based on the static data and subsequent analysis of the T-1 configuration (references 20 & 13), failure behind the plug is attributed to the magnitude of the plug loading, the eccentricity of the load application (at the ribs), and the presence of the longitudinal joints separating the 110° arc roof panels from the remaining trench



EXPECTED BEHAVIOR PRIOR TO PLUG LOADING

($t = t_1$)

FIGURE 5. GENERALIZED RESPONSE TO INTERNAL LOADING

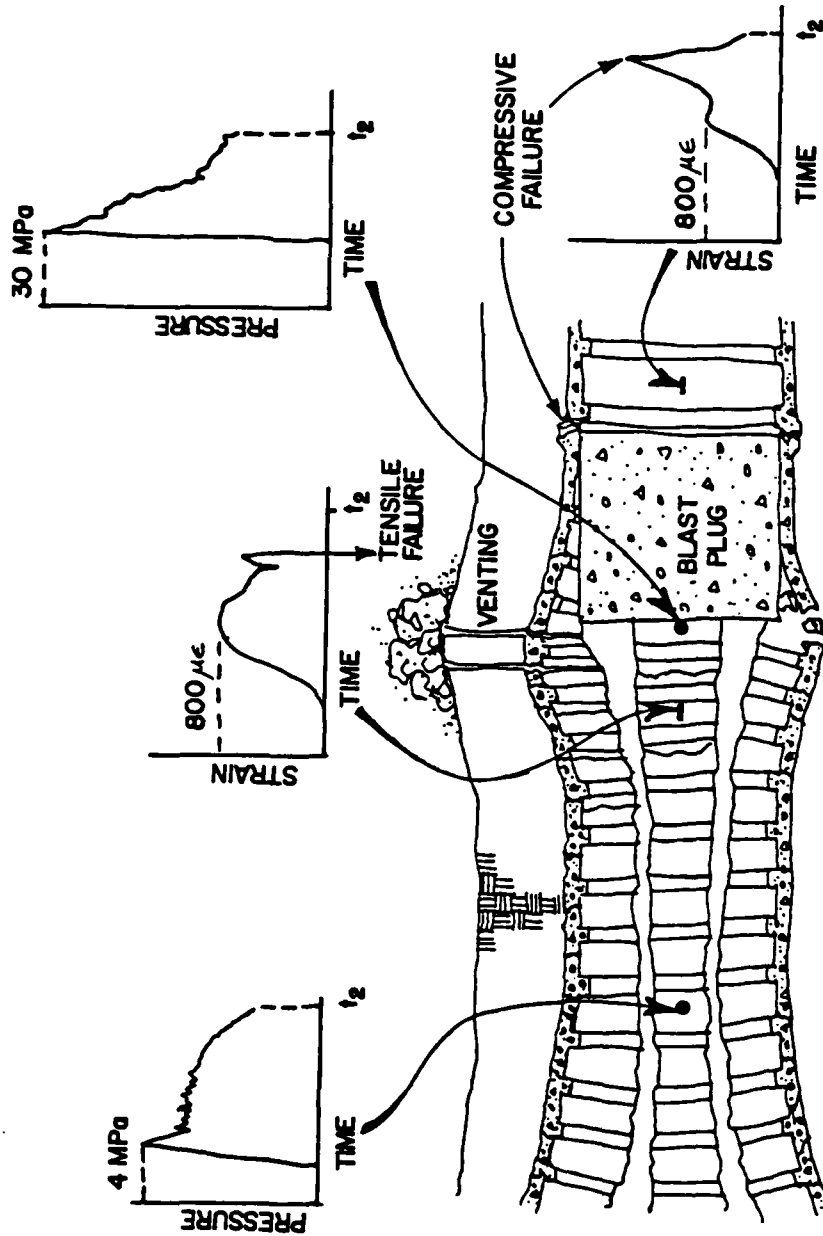

EXPECTED BEHAVIOR AFTER PLUG IS LOADED
($t = t_2$)

FIGURE 5. GENERALIZED RESPONSE TO INTERNAL LOADING
(CONT.)

structure below. While the transverse bell and spigot joint appeared to influence the behavior at failure, it is not believed to be a primary cause of failure.

The response behavior at the front of the plug also differed from prediction. Expansion of the wall adjacent to the plug was expected based on two-dimensional analysis of a cross-section of the trench at the face of the plug (reference 20). This expansion did occur from the face of the plug back to the first engaged rib. At this point the trench wall failed circumferentially limiting the zone of expansion. The failure was attributed to a combination of shear due to expansion and tension from the plug loading. An additional factor may have been the extremely close fit of the plug with the trench structure. The plug was cast directly against the trench wall separated only by a coat of paint to prevent bonding. This consideration influenced a redesign of the cast in place plugs for T-2.

The second major contribution of T-1 was to provide data on the interaction of the trench ribs with the internal airblast. This interaction couples loading into the trench wall which outruns the airblast and arrives at the blast plug prior to arrival of the airblast. In addition, the secondary shock formed by the collision of the airshock with the ribs is strong enough to perturb the main shock flow in the trench. The primary effect is to convert kinetic energy in the flow to enhance the static overpressure and subsequently to accelerate expansion of the trench. This effect is ultimately important to the designer because of its reduction of the loading measured at the plug. The rib loading coupled into the wall is significant if it reduces the effective capacity of the wall to resist plug loads.

T-1 pretest analysis indicated that longitudinal compressive strains of approximately $800 \mu\epsilon$ due to rib loading would arrive at the plug prior to the

airblast, reducing the remaining capacity for plug loading to approximately two-thirds of the unloaded wall capacity (figure 5). Although blast pressure data recorded in T-1 confirmed pretest analysis of the rib shock interaction process, the longitudinal data showed substantially lower outrunning strains. Maximum outrunning compressive strains of $150 \mu\epsilon$ were recorded in the trench walls and no clearly observable outrunning was evident in the roof panels. Again, the transverse joints were suspected of influencing test results. Subsequent analysis would show that the shock propagation was slowed by the joints and later testing would provide higher measured values of outrunning strain. However for T-1, outrunning strain was not a significant factor in response.

The T-1 test established the fundamental aspects of loading and response behavior for a known internal environment. It also raised questions about the capability of the baseline design to react plug loading. This data was particularly important as it came at a time when system planners had just altered the baseline design to reduce projected system costs.

Late in 1976, the program office for MX development (The Space and Missile Systems Organization or SAMSO, now the Ballistic Missile Office or BMO) convened a "Blue-ribbon Panel" chaired by Dr. Newmark of the University of Illinois to review the baseline concept design. This panel considered only transverse response from external loads, and, based on the information presented them, the panel concluded that the design was excessively conservative. Early in 1977, SAMSO initiated a 90 day study to define a less conservative base line. The Air Force Weapons Laboratory (AFWL) participated in the study and based on experimental and analytical studies recommended

1

against reducing the baseline capacity (reference 3). Despite this recommendation, an alternate baseline was adopted in May 1977, which was identical to the original baseline except that the wall thickness was reduced by one-third to ten inches (254 mm), the amount of fiber reinforcing was reduced by three-quarters to one-half percent, and the nominal concrete strength was increased from 6000 psi (41 MPa) to 8500 psi (59 MPa). Refer to figure 3 for the original baseline design. The decision to change the baseline came at a time when the test model construction for T-1 was already complete. To change the wall thickness for T-2 would have required the fabrication of new forms and would have substantially delayed the test. As a result, T-1 was conducted as planned and only three changes were made to T-2. The concrete strength was increased and the steel fiber percentage was reduced to match the new baseline values. Also, the roof panels were eliminated so that the structure could be cast as a continuous cylinder. This last change reflected a revised estimate of breakout requirements and capabilities.

Although the data from T-1 was not expected to be available in time to alter the design of T-2, recommendations based on T-1 results were included in a redesign of the blast plugs for T-2. The number of ribs engaged was reduced to two to conform with current mechanical plug design concepts and the design of the rib engagement was altered to prevent the cast in place plug construction from influencing expansion and wall failure at the rib engagement.

The half-sized T-2 test is described in figure 6. As with T-1, the major emphasis of the test was to obtain fundamental loading and response data. However, T-2 included the simulation of the external airblast environment which would accompany the internal environment during an attack. This external environment, unlike the internal environment could be relatively well

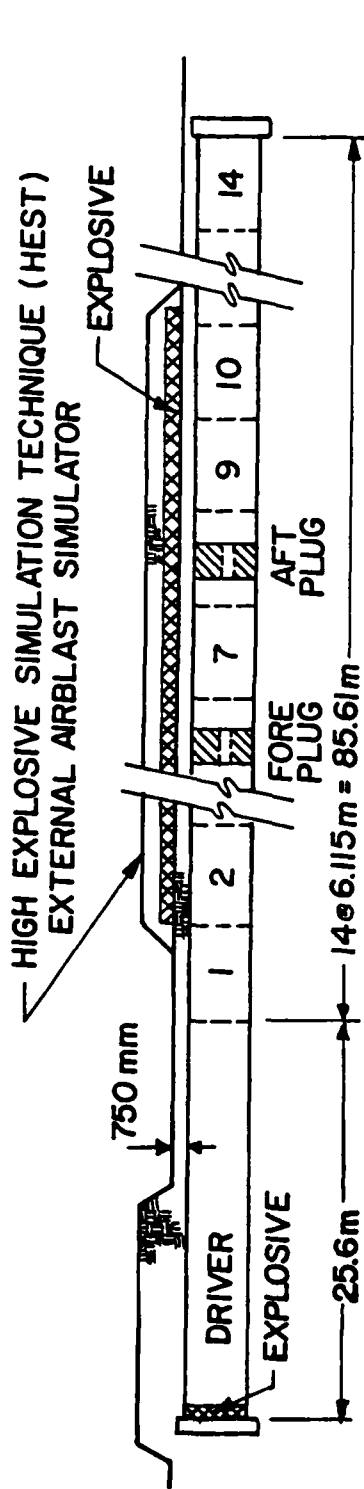

TEST SCHEMATIC

TRENCH SECTION DESIGN

- SAME GEOMETRY AS T-1
- $C = 1/2$ % FIBER
- $f'_c = 8500$ psi (59 MPa)
- NO LONGITUDINAL JOINTS
- NO TRANSVERSE ROOF JOINTS

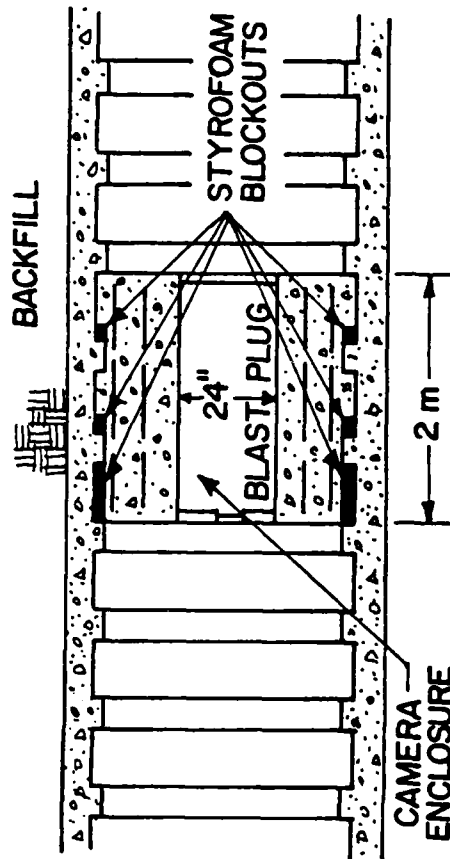

FORE PLUG DETAIL

FIGURE 6. T-2 TEST CONFIGURATION

characterized for a given attack scenario. The major effects of this external environment were to offer restraint to the trench expansion ahead of the blast plug region and to provide external loading resulting in displacement and deformation of the trench structure behind the blast plug. Another, important effect of the external loading was to reduce the longitudinal motion of the trench (due to internal rib and plug loading) by increasing the longitudinal shear resistance at the soil-structure interface.

In addition to examining the importance of external loading, the study of trench-plug interaction in T-2 was continued. While contractors for SAMSO were developing mechanical blast plug designs to attenuate the loading applied through the ribs to the trench wall, the T-2 test examined basic rib shear behavior and the concept of a simple two plug system to attenuate internal loads. In this dual plug concept, the first plug would couple the full internal loading into the trench structure forcing rib shear and/or wall failure in the region between the two plugs. The bulk of the energy associated with the internal shock would be dissipated first through inelastic damage to the ribs and trench wall adjacent to the first plug and between the plugs and finally through venting from the damaged trench. The second plug would see much reduced loading and could safely protect the missile and launcher.

Pretest analysis for T-2 (reference 22) examined the longitudinal response of the trench. This analysis gave the first estimate of the importance of shear resistance at the soil-structure interface to longitudinal response. Three calculations were performed to predict the longitudinal response of the trench wall behind the plug due to loading from the internal airshock. The

/

first was a simple single degree of freedom calculation as shown in figure 7a. The mass used was the mass of the fore plug and the stiffness was based on the trench wall between plugs. The force time history was simplified from the predicted loading on the plug but matched peak force and total impulse at 20 ms. The resulting peak force in the spring was 190 MN (43 million lbs). The second calculation was a one dimensional multiple degree of freedom analysis described in figure 7b. This analysis represented each of the fourteen 6 meter trench sections with four masses and springs. Mass and stiffness values were increased at each plug location so that the plugs were modeled integrally with the trench sections. The numerical values were derived in a manner consistent with the single degree of freedom analysis. The soil at the downstream end of the trench model was also represented by a series of masses and springs. Two forms of loading were applied. Each of the 21 masses upstream of the fore plug was loaded with a force (F_{Ri} for the i th mass) which represented the drag force of the internal shock on the ribs. The magnitude and time of arrival (TOA) of these forces were adjusted for each mass, but the waveform used was constant as shown in figure 7b. This loading was derived from the analysis of an axisymmetric hydrodynamic calculation of flow in the ribbed trench. The second type of loading was the direct plug loading applied at Mass 22 which was also analytically derived. The multiple degree of freedom analysis differed from the single degree of freedom analysis primarily by accounting for the internal loading and response of the trench upstream of the fore plug and by accounting for the deformation of the trench from the rear plug downstream. The effect of modeling the upstream region was to generate an outrunning force of 22 MN (5 million lbs, 22% of the static

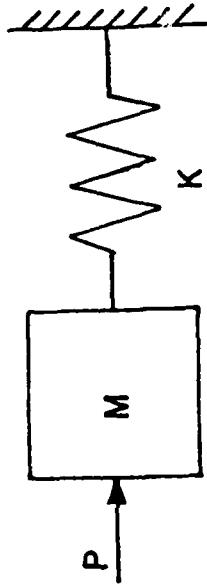
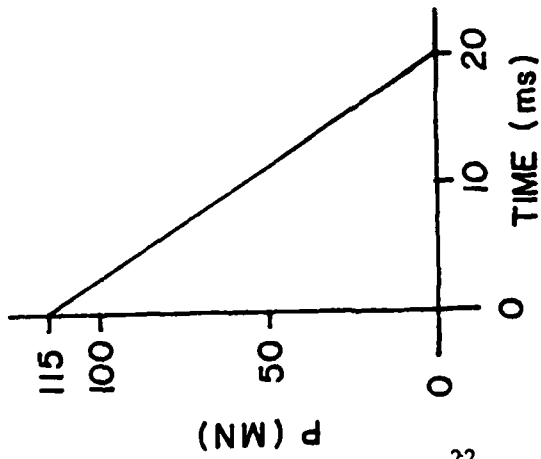

$M = 22500 \text{ kg}$ (FORE PLUG MASS)
 $K = 4.87 \text{ GN/m}$ (STIFFNESS OF TRENCH BETWEEN PLUGS)

FIGURE 7a. SINGLE DEGREE OF FREEDOM ANALYSIS

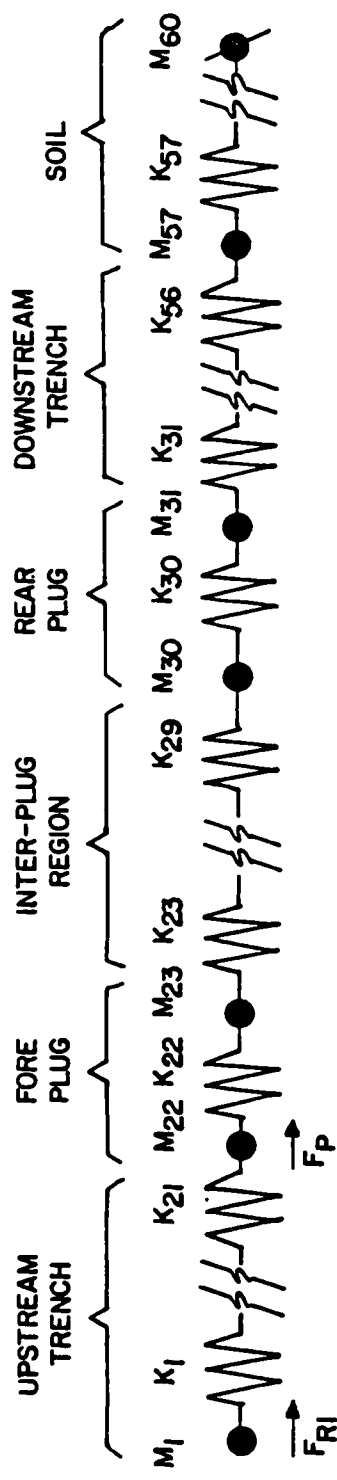

$M_{22}^{\circ} M_{23}^{\circ} M_{30}^{\circ} M_{31}^{\circ} = 12,750 \text{ kg}$
 $K_{22}^{\circ} K_{30}^{\circ} = 95.3 \text{ GN/m}$
 OTHERWISE M_1 THROUGH $M_{56}^{\circ} = 6,330 \text{ kg}$
 OTHERWISE K_1 THROUGH $K_{56}^{\circ} = 38.5 \text{ GN/m}$
 SOIL: M_{57} THROUGH $M_{66}^{\circ} = 14,000 \text{ kg}$
 SOIL: K_{57} THROUGH $K_{65}^{\circ} = 1.4 \text{ MN/m}$

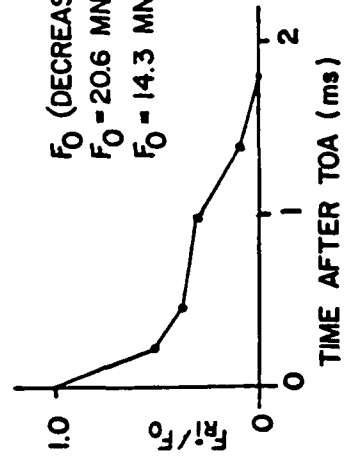

RIB LOADING WAVE FORM

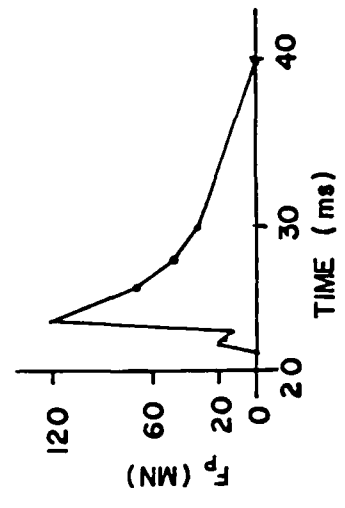

PLUG LOADING

FIGURE 7b. MULTIPLE DEGREE OF FREEDOM ANALYSIS

wall capacity) in the upstream wall of the trench prior to arrival of the plug loading. The more dramatic effect of including the downstream portion of the trench was to reduce the peak force due to plug loading in the region between the plugs to 40 MN (9 million lbs). This 80 percent reduction of the force estimate provided by the single degree of freedom analysis resulted by allowing deformation and displacement of the rear plug and the trench downstream. While the results of these two calculations may be taken as bounds on the axial response of the trench wall between the two plugs, the expected behavior ranges from essentially elastic to failure (based on a calculated static axial wall capacity of 98 MN or 22 million lbs). While the rigid downstream boundary condition in the single degree of freedom analysis clearly leads to unrealistically high wall force estimates, the multiple degree of freedom analysis provides low estimates by ignoring the longitudinal shear force which develops at the soil structure interface and which resists the downstream motion of the trench. To gain an improved estimate of the influence of this force, an axisymmetric finite element calculation was performed. The geometry of the calculation is shown in figure 7c. The calculation included the entire test model surrounded by an annulus of soil in the axisymmetric representation. Rib loading and the internal normal pressure were applied sequentially upstream of the fore plug to model the loading of the internal airblast running toward the plug. An appropriately timed pressure time history was applied to the plug. The external airblast loading was also applied sequentially to the surface of the soil. To match the test design condition the arrival of the external shock was approximately five milliseconds behind the arrival of the internal shock. The interface between the soil and structure was represented with a sliding, debonding interface

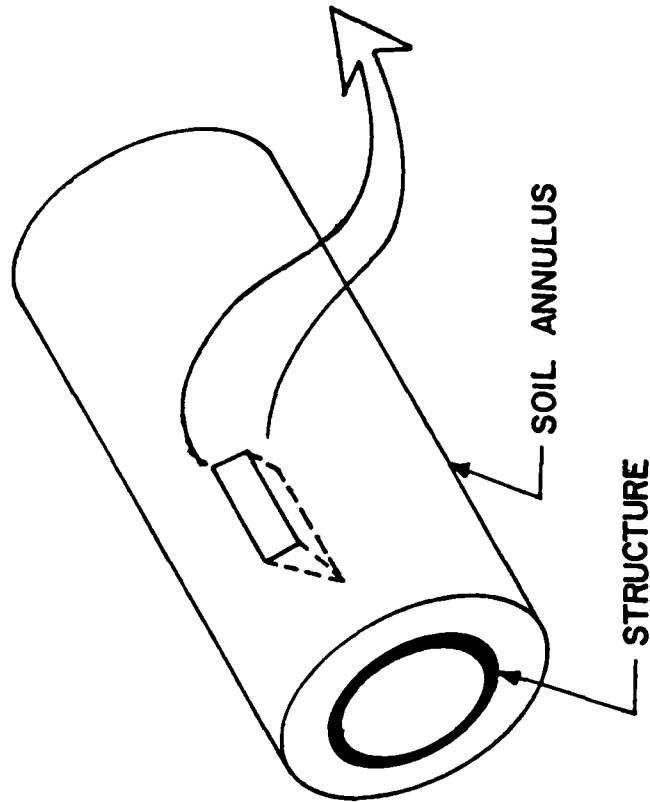
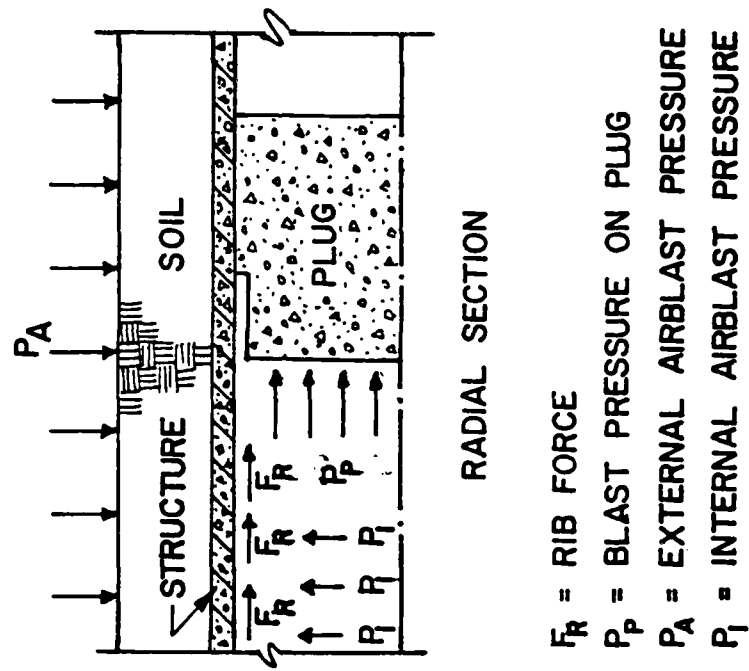

FIGURE 7c. AXISYMMETRIC FINITE ELEMENT ANALYSIS

with a Coulomb friction model. The SAMSON structure-media interaction code used in the analysis is described in reference 1.

Using internal loading and material properties consistent with the previous two calculations, the finite element calculation predicted an outrunning wall force of 5.8 MN (1.3 million lbs) compared with 22 MN (5 million lbs) in the multiple degree of freedom analysis. The peak wall force immediately behind the plug was predicted to be 95-115 MN (21.4-26 million lbs) compared to 40 MN (9 million lbs) in the multiple degree of freedom analysis and 190 MN (43 million lbs) in the single degree of freedom analysis. Since the soil stress due to the external airblast environment attenuates rapidly with depth in the dry sandy soil, the effect of external shear was over-emphasized in the calculation. Ahead of the plug, this shear force acts to attenuate rib induced loading while close behind the plug it tends to increase the wall stresses due to plug loading. This error was not considered to be too significant because the five millisecond delay in external loading in general caused the effects of the external force to appear only after the peak longitudinal strain had occurred. Post test analysis revealed that the actual internal environment was different from the values used in the predictions. The peak pressure was slightly high, but within ten percent of the value used in the predictions. However, the impulse delivered to the plug during the first twenty milliseconds of loading was thirty percent low and the delay between internal and external shock fronts was only 2.6 ms. Forces in the trench wall were calculated from experimental strain data using standard test day material property data and the approximation of elastic behavior. The out-running force derived by this method (reference 14) was 30 MN (6.7 million lbs) while the plug induced force was 76 MN (17 million lbs). Comparing the

experimental results with the pretest calculations was not entirely straightforward. The reduced impulse was shown to have significantly reduced the plug induced loading in the wall. The source of the higher than expected out-running strain could not be directly traced, but it appeared to have been affected by shock loading coupled directly into the wall by the explosive driver and not modeled in the analysis.

However, the most significant result of the comparison of the experimental data with the calculations was the confirmation of the external shear loading as a major contributor to the longitudinal response. The measured wall response to plug loading was almost twice the value predicted in the multiple degree of freedom analysis despite the reduced experimental plug loading. The results were far more closely represented by the finite element analysis including longitudinal shear effects.

The results of the axisymmetric analysis were also used to predict that rib shear would occur at the fore plug. The ribs were not modeled explicitly in the calculation. Rather, rib shear was inferred by comparing the calculated force transmitted by the plug to the wall with a calculated static rib shear capacity. The calculation also indicated expansion of the trench wall along the side of the fore plug up to the first engaged rib where shear and flexural failure of the wall would occur.

A two-dimensional plane strain analysis of a transverse cross section of the test model under external loading was performed using the SAMSON code. The geometry of the calculation is shown in figure 8. Based on the results of this calculation collapse of the region between the plugs and behind the

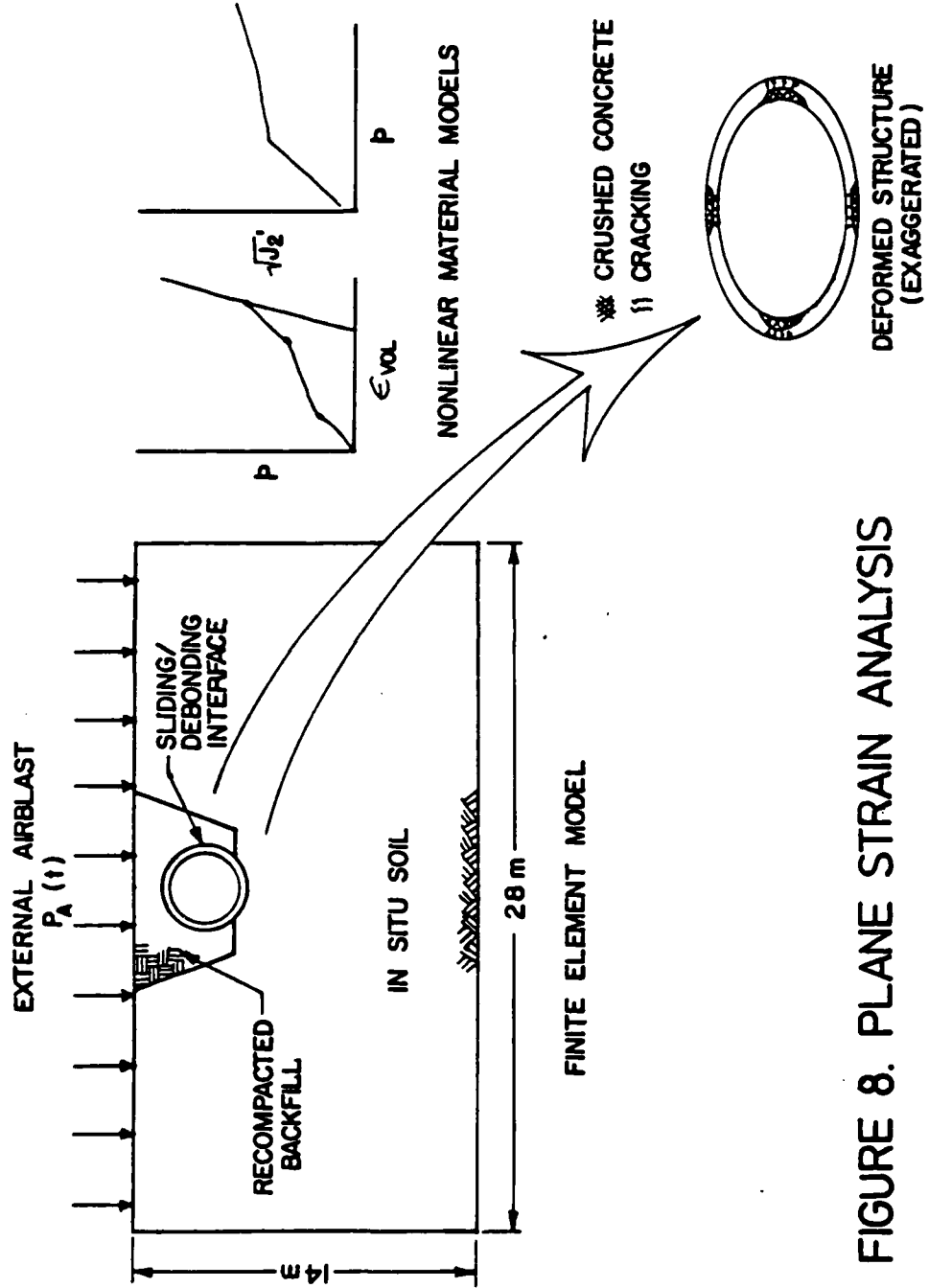

FIGURE 8. PLANE STRAIN ANALYSIS

second plug due to external loading was not expected. However, local wall failure (concrete crushing, substantial cracking) at the crown, springline and invert associated with transverse bending of the cross section in the primary bending mode was predicted.

The actual T-2 test results in general confirmed the predicted results (references 22 and 14) with some exceptions. The wall adjacent to the blast plug did expand and the plug sheared both engaged trench ribs and the next rib back, before coming to rest on the second rib past its original position. The concrete rib engagements on the plug itself were severely damaged. Blast pressure measured in the region between the plugs showed that low level (25 psi or 180 kPa) pressure did get past the first plug. The external airblast loading did cause local wall failure at the crown, invert and springline in the region between the plugs and behind the second plug as predicted. However, the wall damage in the region between the plugs was sufficient to cause collapse. In addition, external load damage to the region behind the second plug was extensive and this region appeared near collapse (figure 9).

After the T-2 test, a substantial change in the baseline design occurred. Instead of providing a uniform design for the entire twenty mile trench structure, the new hybrid concept provided a series of hardened parking segments connected by a soft tunnel structure. The capacity of the hardened regions would be substantially increased when compared with the concepts tested to date.

The analysis of experimental data from T-1 and T-2 made significant contributions to the decision to alter the baseline. The first contribution was to clarify internal loading behavior. The two tests provided a basic

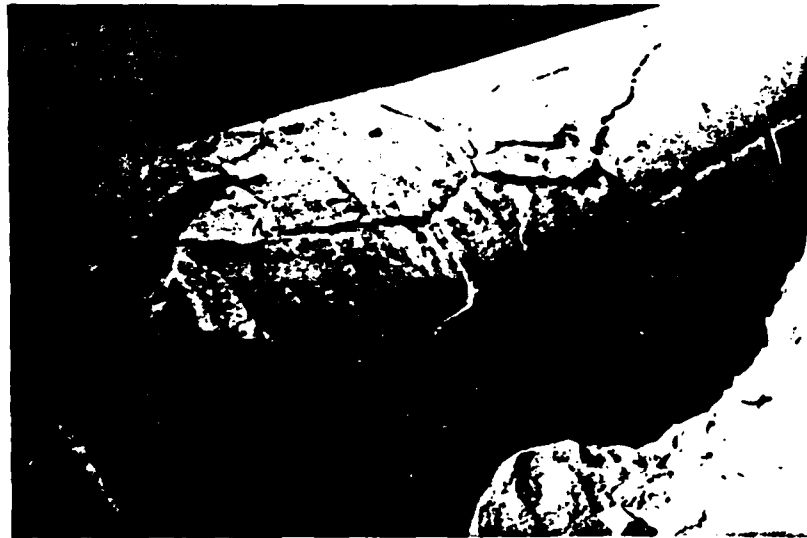

EXTERNAL DAMAGE
AT REAR PLUG

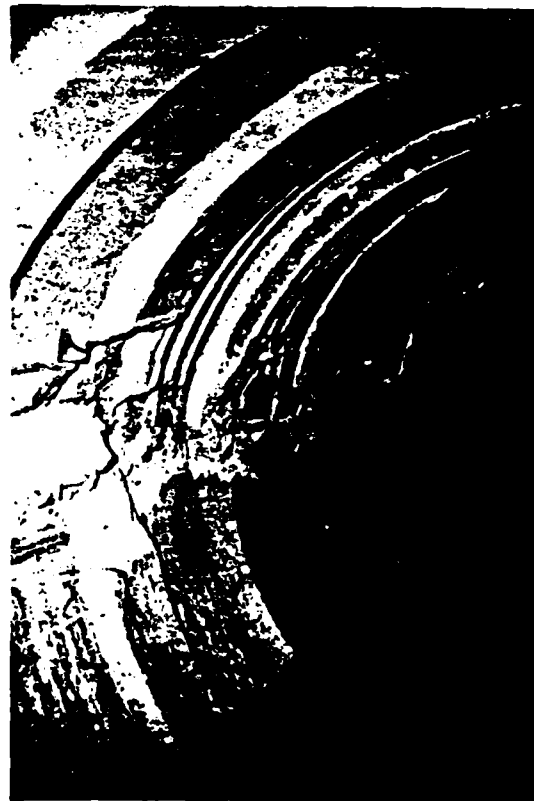

COMPRESSIVE FAILURE
AT SPRINGLINE
(BEHIND REAR PLUG)

FIGURE 9. POST TEST DAMAGE NEAR REAR PLUG

description of the loading coupled into the trench near a blast plug for simplified plugs and a known incident internal airshock. Comparisons of calculations with experimental data confirmed the ability of analytical methods to provide reasonable estimates of loading, accounting for local effects of rib attenuation and wall expansion. However, the far more difficult job of predicting the incident internal environment which provides the initial conditions for the loading calculations was not yet complete. For a more complete description of the problems associated with calculating initial coupling and the effects of upstream attenuation see reference 26. Regardless, using the predictive techniques evaluated in T-1 and T-2 and the best estimate incident environment, it was clear that significant outrunning strain could be expected from airblast loading of the ribs and substantial load attenuation would be required from the mechanical blast plugs to prevent rib shear or wall failure in the trench.

The second contribution was to provide basic data on the behavior of the trench in the region of the plug. In T-1, wall expansion was stopped at the first engaged rib through a combined shear and tension failure of the wall. Since the cast in place construction of the T-1 plug was thought to have influenced the wall failure, the design of the T-2 plugs was revised. In T-2 substantial wall expansion alongside the plug did occur, but not enough to completely disengage ribs or to allow substantial pressure penetration behind the fore plug. Three one-thirteenth size dynamic tests conducted by AFWL's Civil Engineering Research Facility also indicated that wall expansion would limit rib engagement (reference 11) and that a reduction of fiber percentage from two to one-half percent significantly lowered the energy dissipated in

rib shear. The models tested had wall dimensions scaled from T-1 and T-2 designs and used nominal 8500 psi (59 MPa) concrete. In all tests, substantial rib shear, wall damage and pressure penetration beyond the plug due to wall expansion were experienced. In addition, a quarter-size test of a mechanical blast plug concept developed the Martin Marietta Corporation was conducted by the AFWL as a precursor to the T-5 event (reference 4). The trench response in this test produced a catastrophic failure of the trench-plug system. The wall design was essentially scaled from T-2 with one-half percent fiber reinforcing and a design concrete strength of 8500 psi (59 MPa). The rib dimensions and spacing were altered to match the Martin Marietta plug design. Failure in the test was initiated when the outrunning compressive shock in the trench wall accelerated the trench wall downstream with respect to the plug. At the arrival of the internal airshock at the first engaged rib, the outward and downstream motion of the trench wall provided a gap for pressure penetration to the region between the two engaged ribs. Subsequent expansion of the trench wall adjacent to the plug occurred so quickly that the first rib was never engaged and the effective capacity of the second rib was reduced. The plug translated approximately 1.26 m, shearing two downstream ribs, before coming to rest. As a result of the larger and smaller size testing and associated analysis, the behavior of continuously hardened baseline concepts in the region of a blast plug was determined to be unacceptable. The smaller size testing in particular had demonstrated problems with expansion under internal loading. In addition, the results of T-1 and T-2 had raised concerns with the mechanical plug designers for the capability of fiber reinforced concrete ribs and wall sections to react the

anticipated plug forces. With the shift to the hybrid "Hardened Aim Point Concept," baseline designs would have substantially increased capacity, not only to resist expansion, but to accommodate plug forces as well.

The third major contribution was the demonstration in T-2 of the damage that might be expected from external loading in the lightly fiber reinforced trench. This confirmed the severe damage behavior observed with one-sixth size models added to the S-1 and S-2 tests. In the S-2 test, side-by-side comparisons of original and alternate baseline structures indicated that while both models had substantial damage, the thinner wall alternate baseline suffered the most severe damage (reference 21). The amount of deformation of the cross-section was substantially larger than predicted in the pretest finite element analysis. This discrepancy highlights the difficulty of predicting behavior when material failure occurs but prior to collapse. Extensive improvements to constitutive models and numerical techniques are required to model this behavior accurately. Providing the capacity to resist external loading for the region where the missile launcher would be parked would continue to remain a concern. Solutions would have to accommodate missile breakout and launch requirements. A suitable design concept had not been demonstrated at the time the preferred basing mode was changed to the vertical shelter.

The main objective of both the T-3 and T-5 tests was to demonstrate the performance of the mechanical blast plug designs developed by the Boeing Company and Martin Marietta Corporation. The test configurations are shown in figures 10 and 11. For the concrete trench structure, the most significant aspects of behavior were the response of the hardened sections to plug induced loading and the response of test sections behind the plugs to external loading.

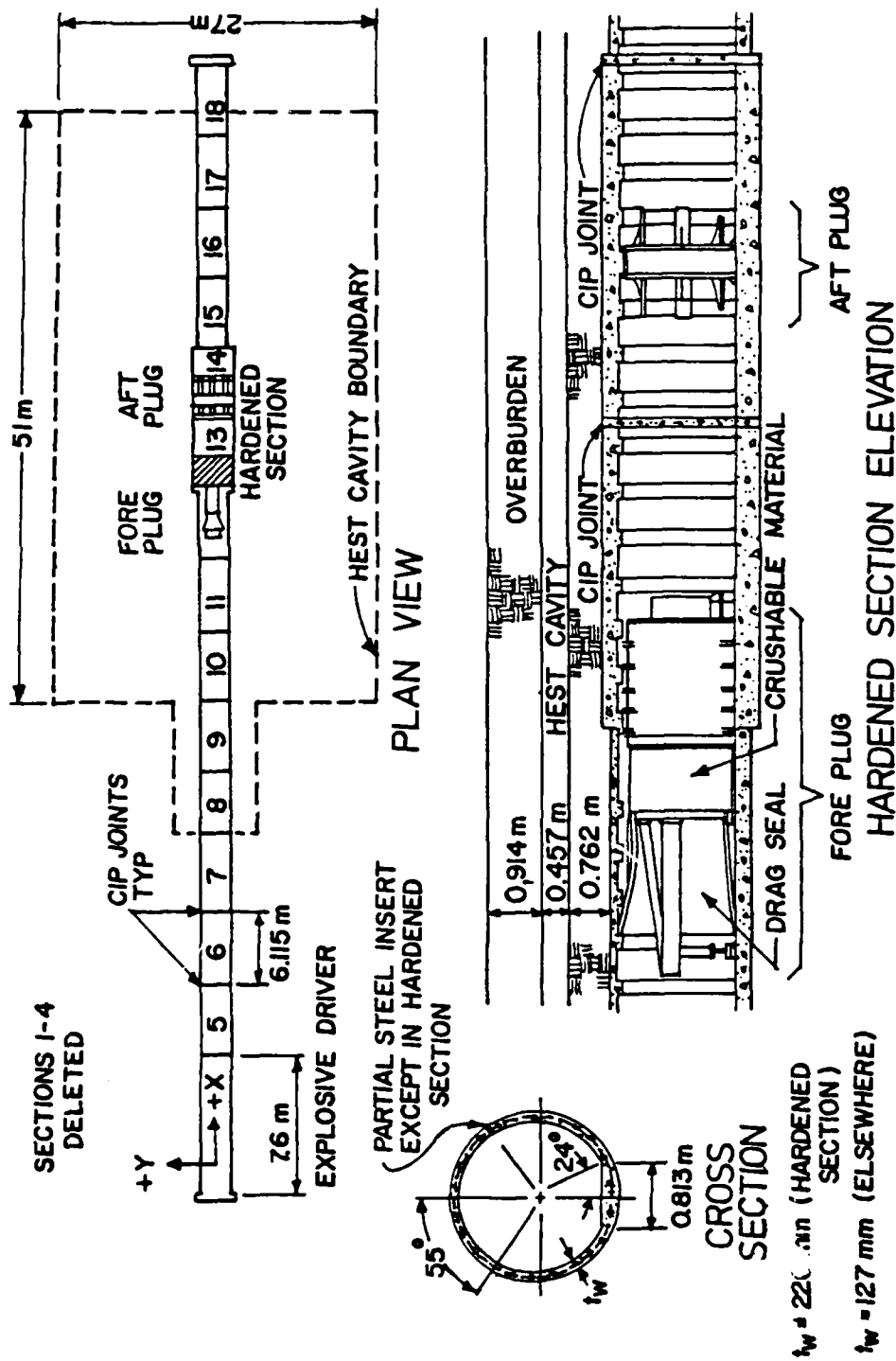

FIGURE 10. T-3 TEST CONFIGURATION

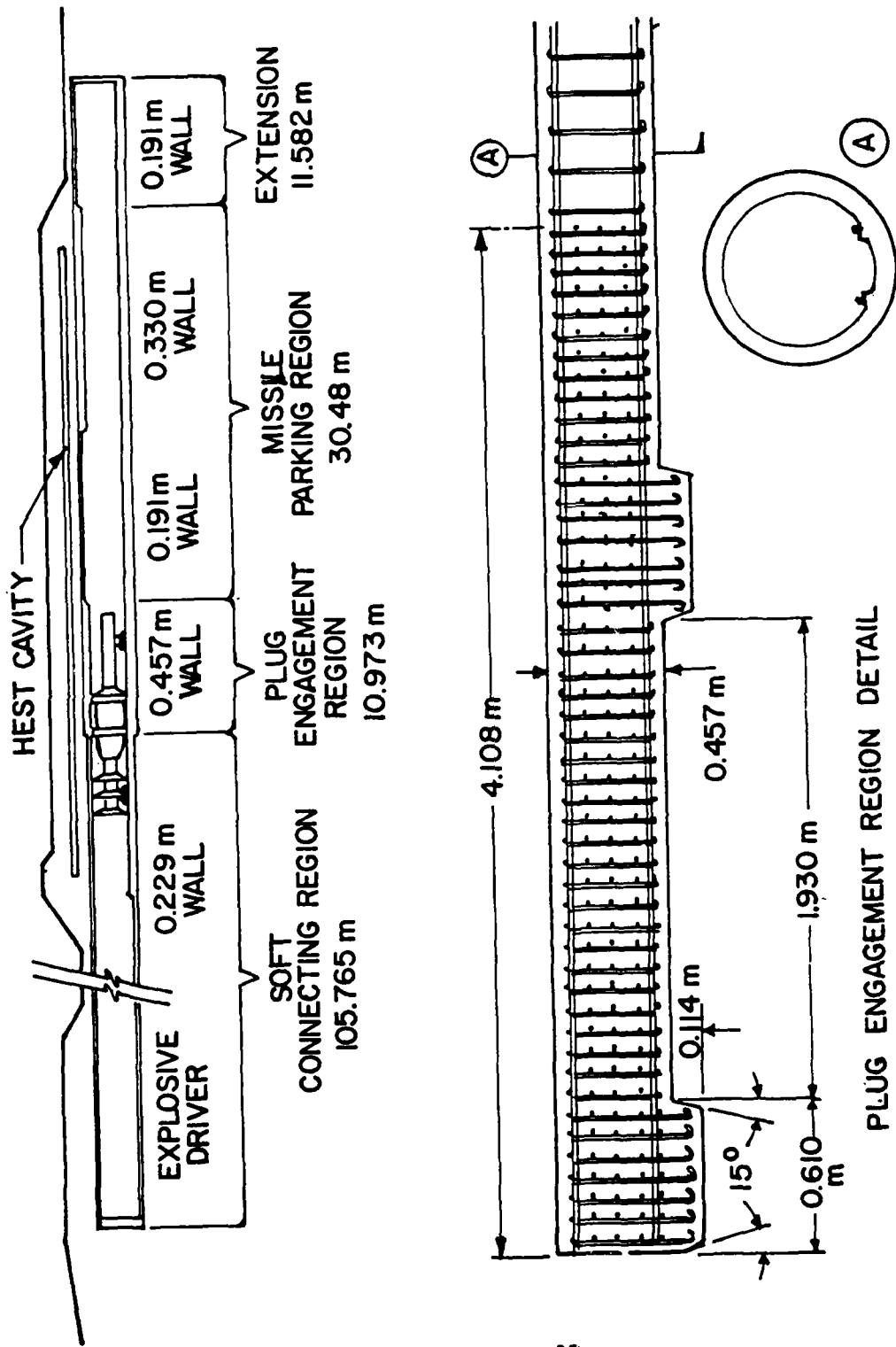

FIGURE 11. T-5 TEST CONFIGURATION

For the half-sized T-3 test, model trench sections were already under construction when the decision to change to a hybrid baseline was made. The test structure originally would have modeled the alternate baseline configuration (full size wall thickness = 10 inches or 254 mm, $f'_c = 8500$ psi or 59 MPa, one-half percent fiber reinforcing). The test was modified by using the already constructed alternate baseline models to represent the soft connecting tunnel and by constructing two hardened sections to model the plug engagement location (Sections 13 and 14, figure 9). The region where the missile would park was not modeled, but alternate baseline sections were placed behind the hardened section to react the longitudinal stress created by the internal loading. The hardened section contained two percent conventional reinforcing in both the longitudinal and circumferential directions. The test day concrete strength averaged approximately 70 MPa (10,000 psi) in soft connection regions and 67 MPa (9700 psi) in the hardened region. The connection between soft and hardened regions was designed to limit shear to reduce wall expansion at the plug engagement location. The design of the hardened region was straightforward in all aspects except for predicting the shear capacity of the ribs.

The method proposed by the AFWL was empirically derived and fundamentally based on a study performed in 1973 for SAMSO (reference 19). Specimens were loaded quasi-statically to failure. Concrete strength, shear reinforcing and normal confining stress (σ_n) across the shear plane were varied during testing. Experimental data is shown in figure 12 along with the recommended analytical expression for maximum shear stress (τ_{max}). This expression is a summation of three terms representing the contribution of the concrete, the

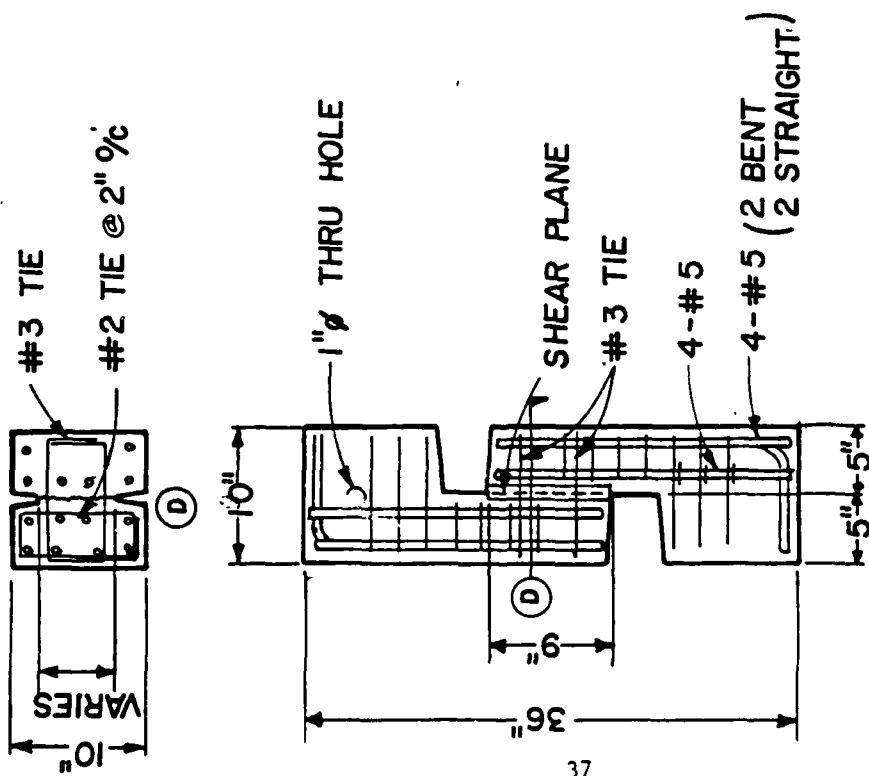
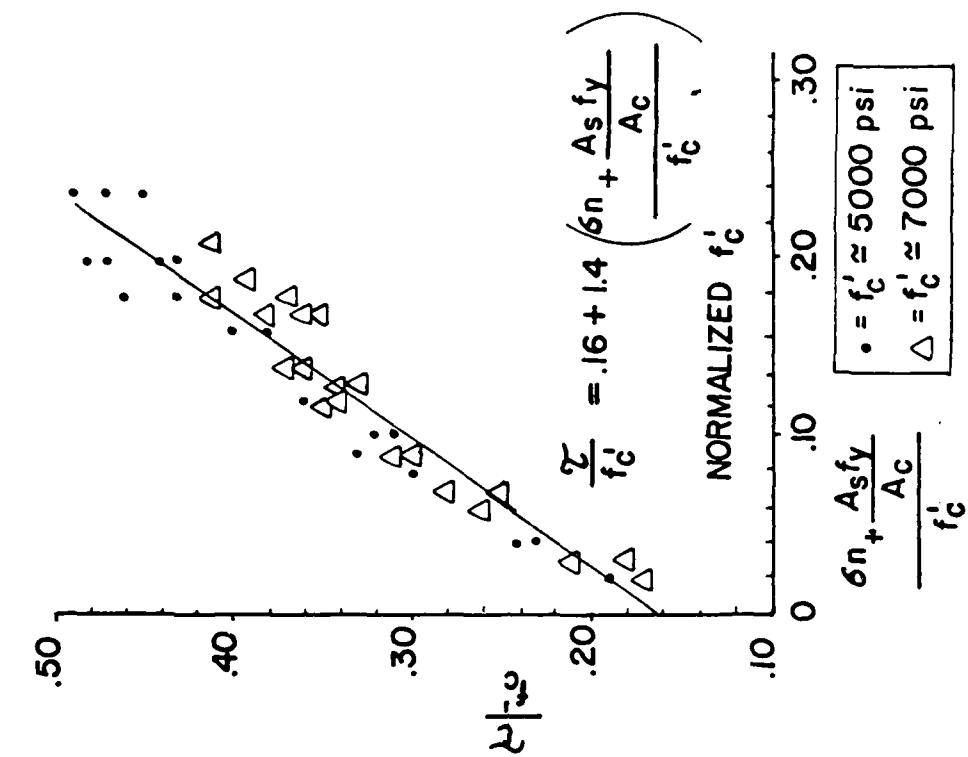

FIGURE 12. KARAGOZIAN & CASE SHEAR STUDY RESULTS
 (REFERENCE 19)

confining stress and the steel shear reinforcing. The third term is identical to the American Concrete Institute shear friction formulation (ACI 318-77, reference 18). At the AFWL, the first term was revised based on the static rib shear data in reference 10. The recommended expression is:

$$\tau_{\max} = .1 f'_c + 1.4 (\sigma_n + A_s f_y / A_c)$$

where A_s = cross-sectional area of shear reinforcement across the shear plane

A_c = cross-sectional area of concrete along the shear plane

σ_n = externally applied confining stress normal to the shear plane

f'_c = unconfined compressive strength of concrete

f_y = yield stress of shear reinforcement

The above expression was developed after the T-3 design was finalized, and predicted that the design would have a margin of safety exceeding sixty percent. During the test, although the fore plug attenuation and sealing mechanisms did not perform as expected, the trench section did not fail under expansion nor was rib shear a problem. Because the fore plug was not totally effective, the region between the plugs experienced a pressure pulse with a peak of .85 MPa (125 psi) and relatively long duration of 240 ms. This was successfully resisted by the aft plug, demonstrating the value of a dual plug concept.

The T-3 test provided the first experimental data for large size models of the continuously hardened alternate baseline design for conditions of external loading. Based on numerical analysis (reference 23) and the

experimental data from T-2 and smaller sized component tests (reference 7), collapse of the thin wall region behind the hardened blast plugs was not certain, but appeared likely. The difficulty in predicting damage states when substantial cracking and crushing occurs has been discussed. To improve the performance of this region, the backfill stiffness was increased by compacting the backfill to a minimum dry density of 2000 kg/m^3 (125 lbs/ft^3 , 95% of maximum density as determined by ASTM D-1557, Modified Proctor Compaction Test). This value compares with 1760 kg/m^3 (110 lbs/ft^3) for the backfill used in T-2 and also for the insitu soil. However, failure planes between compacted lifts of backfill reduced the effective stiffness observed in the test. As a result the effective constrained modulus for the T-3 backfill was approximately the same as for the insitu soil and approximately twice that of the T-2 backfill. Both theory and previous experimental data established that the stiffer soil would reduce the effective loading and the resulting damage associated with the external loading. The actual test provided interesting results. Substantial local crushing and cracking did occur, and plastic hinges were formed at the crown and invert as well as at the longitudinal separator joint (55° either side of the crown) and at 30° below each springline. Surprisingly, the structures did not collapse immediately. Movies taken during the test show the structures moving to peak response (20 ms) and recovering. When the light fails at 200 ms the structures were still standing. However, the structures had extensive damage and were only marginally stable with six complete hinges formed around the circular section. At about eight seconds after test detonation a very low level groundshock was caused by fall back of the loose soil overburden which had

1

confined the explosives for the external loading simulator and this was sufficient to collapse the structures (reference 15).

The T-5 test was similar to T-3 not only in objectives, but also in results. Although the Martin Marietta Corporation designed blast plug was substantially different in approach and design when compared to the two plug Boeing concept, it also experienced difficulty with sealing and attenuating the internal loading environment. In addition, although T-5 included test sections, behind the blast plug, specifically designed as model parking regions for the missile, the inappropriate design of a longitudinal breakout joint led to the failure of this region under external loading.

As with T-3, the region of plug engagement was specifically designed to accommodate the Martin Marietta plug design. T-5 was a three-quarter size test and the wall thickness in the plug engagement region was 457 mm (18 inches) and contained 1.5 percent reinforcing longitudinally and 6.75 percent circumferentially. The plug engagement region performed satisfactorily despite the higher than anticipated loading transferred to the rib when the shock absorbing mechanical engagement arms on the plug bottomed out (references 16 and 24). The first engaged rib was observed to have crushed longitudinally 80 to 100 mm at the forward face, however no evidence of significant rib shear was seen. The second engaged rib did show shear damage between rails at the invert where the inner hoop reinforcement is not continuous, and minor cracking and spalling of concrete was seen at other locations. The plug did remain engaged and cracking due to expansion was very minor. Despite the larger than anticipated plug response and some pressure penetration, performance of the plug and trench combination appeared to be within the required limits.

The behavior of sections behind the plug in response to external loading was not nearly as successful. The test region behind the plug actually incorporated two separate designs for hardened parking locations for the missile launcher. Requirements to minimize cost and to provide a design which would allow the launcher to break out through the roof of the trench after an attack, lead to lightly reinforced section designs with marginal capacity to resist external loading. The thinner wall section (190 mm or 7.5 inches) had one percent conventional reinforcement circumferentially while the thicker wall section (330 mm or 13 inches) had 0.7 percent. To allow breakout, the circumferential rebar design for both sections contained short (80 mm or 3 inch) splices at 55° either side of the crown facilitating tensile failure of the wall at that location under the erection loading. Similar designs showed satisfactory performance in smaller size testing (reference 7); however, in T-5 this detail proved inadequate to resist the flexure occurring at that location resulting from initial external loading of the crown. The splice on the outer rebar separated in tension forming a longitudinal crack on the outer surface. The wall capacity in shear was then insufficient and the entire roof between splices punched through as a rigid piece. Later testing and analysis of joint sections would provide more suitable joint designs, however the trench concept would be abandoned as a basing concept before candidate designs could be evaluated.

HORIZONTAL SHELTER CONCEPT

This basing concept is essentially comprised of a series of horizontal

bermed shelters connected by a surface road network. A single vehicle per missile served to shuttle the missile between shelters as well as to erect and launch the missile (figure 13). This concept avoided the difficulties of defining in-trench environments and dealing with breakout requirements. It was carried through the concept validation phase of system development as a back-up to the trench concept in the event that the technical issues associated with the trench could not be resolved.

In general, the development of a design was a straightforward process. The two major structural uncertainties addressed during large size testing were definition of the reflected and drag loading on the structure and the evaluation of analytical methods for loading and response to support design and assessment of the structure.

The four large size tests are shown in figure 14. The tests will not be individually discussed in detail; rather, the overall results will be summarized. In addition, reference 9 describes the analysis and component testing which also supported development of this basing mode. The first three tests (S-1, S-2, S-3, figure 14) used a Dynamic Airblast Simulator (DABS) to determine reflected and drag loading waveforms for 0° (head-on), 90° (side-on) and 30° orientations of the shelter with respect to the direction of propagation of the shockfront. The DABS is essentially a large shock tube of corrugated arch construction with a soil cover to reduce early time expansion of the simulator. This technique reproduces the shock flow and subsequently, reflection and drag effects on loading waveforms. One-sixth size instrumented shelter models were used to determine the applied loading and the fundamental response modes. This data was used to evaluate numerical

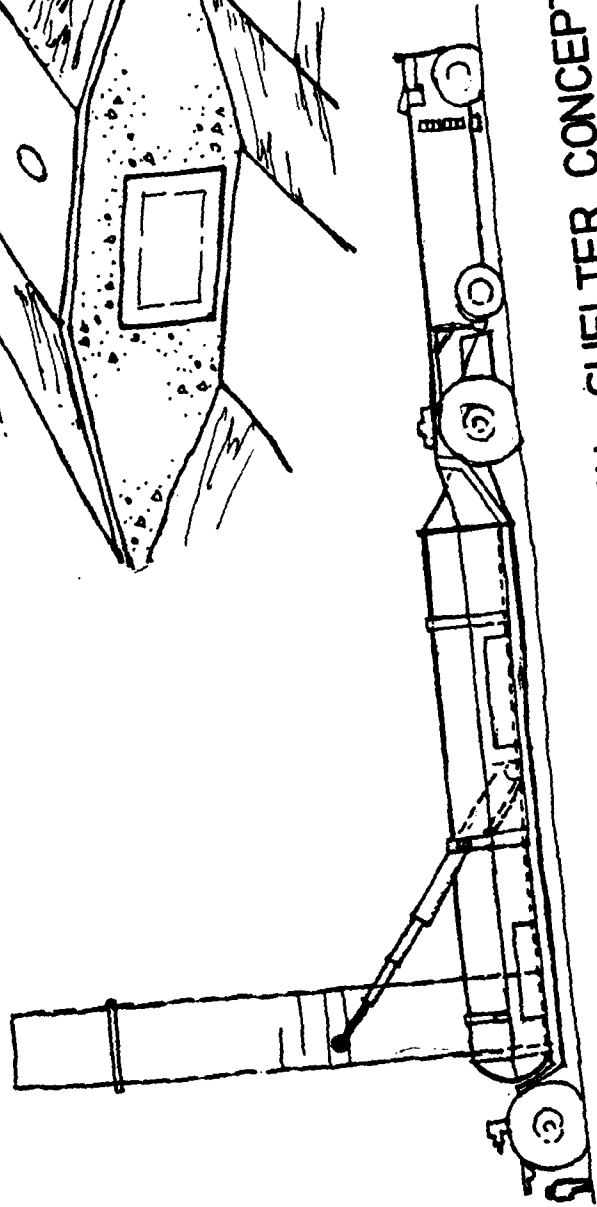
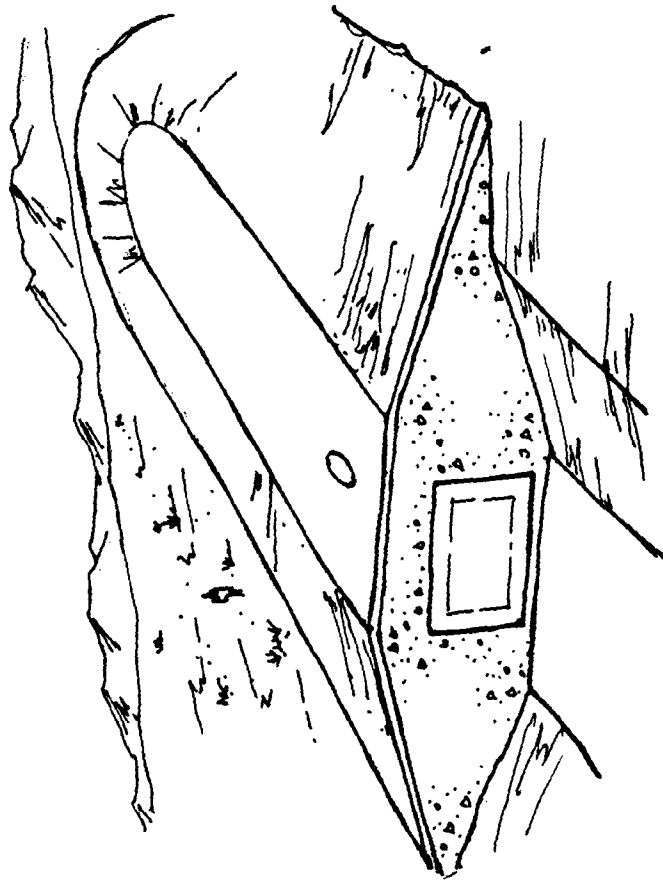

FIGURE 13. HORIZONTAL SHELTER CONCEPT

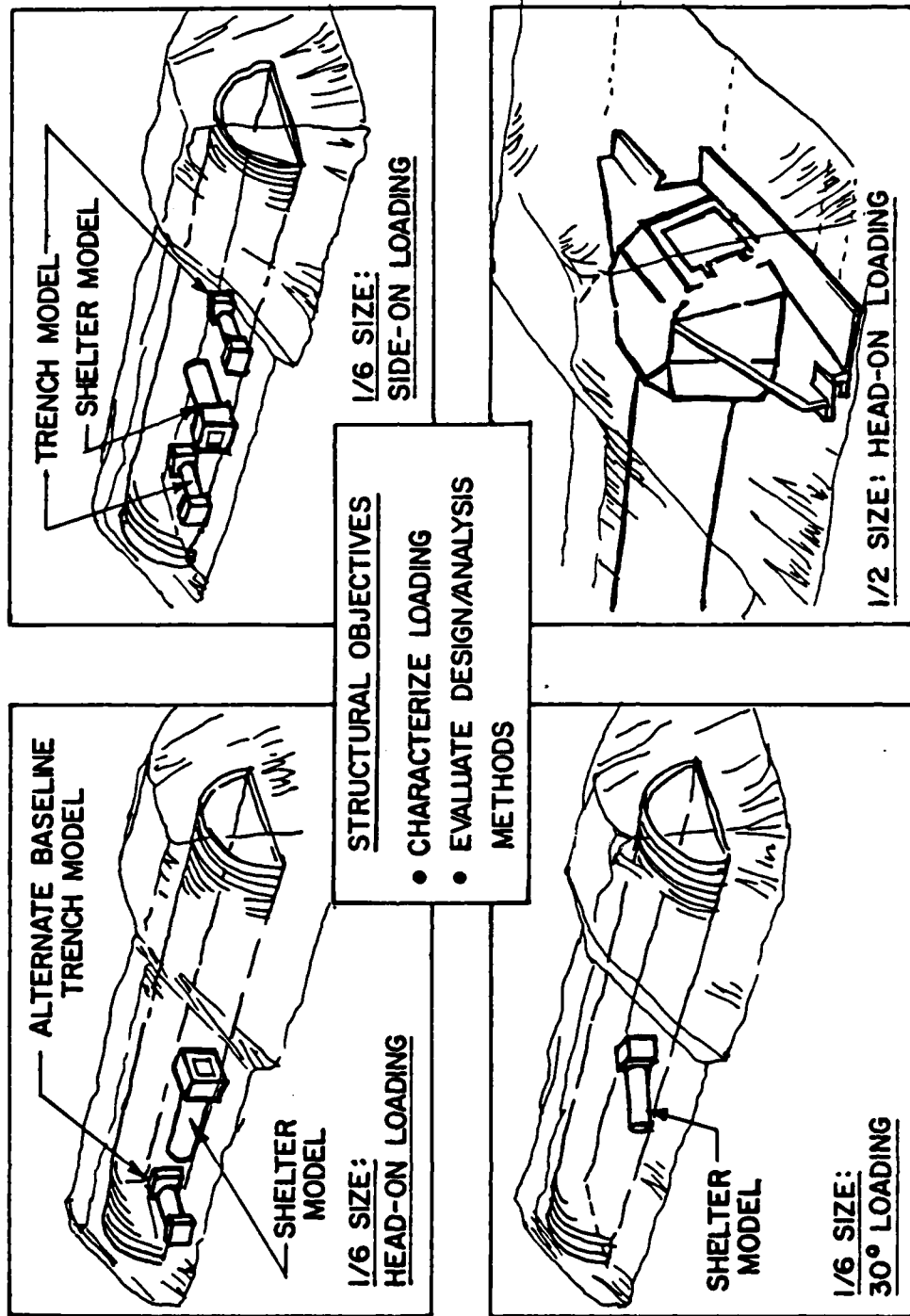

FIGURE 14. LARGE SIZE HORIZONTAL SHELTER TESTS

analysis procedures for airblast loading and for structural response. The final test (S-4) was at one-half size and contained an operational closure and bearing frame designed by the Boeing Company (reference 12). This test loaded only the forward portion of the shelter using a High Explosive Simulation Technique (HEST) to reproduce the loading wave forms defined by the earlier DABS testing and subsequent analysis. The HEST technique uses a thin cavity of explosives to reproduce a specified pressure time history. For S-4, the HEST was designed to reproduce the high pressure (30 MPa, 4400 psi) loading corresponding to reflection and drag effects of a head-on attack. The test model responded as expected with only limited compression damage where the large headworks transitioned into the smaller tube section. The closure opened easily after the test.

As a result of the first tests the headworks design was streamlined to reduce both the magnitude of loading and the surface area exposed to loading. The S-4 test demonstrated a feasible design for worst case attack conditions. The one region where design revision may have been required was the transition from the large load accumulating headworks to the much smaller tube section. Inelastic response seemed unavoidable unless the tube crosssectional capacity was substantially increased. A recommended alternative was a ductile, energy absorbing connection at the front of the tube section.

VERTICAL SHELTER CONCEPT

A number of factors influenced the Air Force decision to adopt a vertically oriented shelter for MX basing. In general, the buried trench

basing mode was abandoned for both technical and political reasons. Technical concerns included not only the design issues discussed above but also uncertainty associated with the nuclear environment coupled into the trench as well as uncertainty associated with the detectability of the missile during normal operations and under a low level attack. Political concerns included cost and issues associated with public access to the basing region. The decision to adopt discrete shelters included consideration of the enhanced structural loading generated by the drag sensitive configuration of the shelter. For the dry deep alluvial valleys considered for basing, a surface flush vertical shelter design would reduce the effective peak blast loading by as much as a factor of eight and, as a result, the hardness and cost required to survive a given threat. However, one advantage of the horizontal concept was the ability to rapidly move the missile (termed a "Dash" capability), since the integral transport and launch vehicle was garaged in the shelters. For the vertical concept, the transport vehicle has to pick up the missile at one shelter and unload it at another. As the entire weapons system design evolved, the requirement for a dash capability was reevaluated and dropped. With this change in requirements the vertical shelter became the preferred basing mode.

Because the majority of the supporting equipment was designed to be incorporated into the cannister containing the missile, the shelter geometry was quite simplified compared to launch facilities for the existing MINUTEMAN or TITAN missiles. An artist's concept is shown in figure 15. The major uncertainty in the design process is the longitudinal shear loading due to relative motion the soil structure interface. The only large size test of this

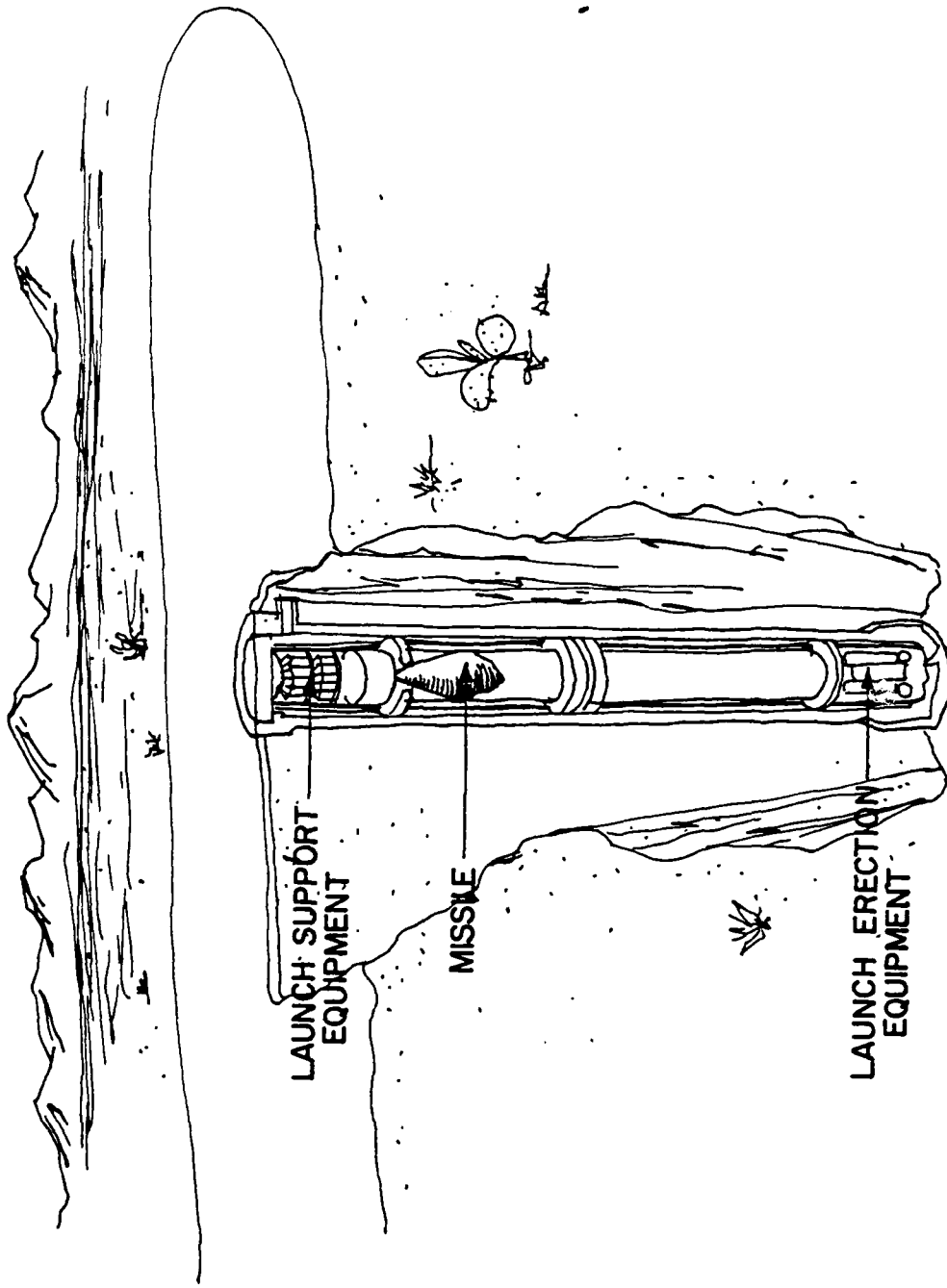

FIGURE 15. VERTICAL SHELTER CONCEPT

basing concept addressed the definition of this shear loading and the influence that it had on the structural response.

The one-third size vertical shelter test is illustrated in figure 16. Three similar models were tested, two designed to respond without significant damage and one designed to have major longitudinal compression damage in the tube wall (reference 25). The reinforcing for all models was one percent longitudinal and two percent circumferentially, at the headworks, transitioning to two-thirds percent circumferentially in the tube section. The A and B models were conventionally reinforced as was the headworks of the C model. The tube section (lower 11 m of the model) was constructed of plain concrete with reinforcing supplied by an unbonded inner steel liner. All models were cast in place against native soil.

The test was extremely successful and provided the first experimentally measured shear loading data for large cast in place structures. The structures behaved as predicted with negligible damage in B and C structures and with substantial crushing of the upper wall of the A structure reducing the overall length by 0.3 m.

The experimental measurements of normal and shear stress at the soil-structure interface were extremely difficult to obtain and there is considerable scatter in the data. The experimental transducer used is described in reference 17. Nevertheless, the basic loading behavior could be established as well as the variation in loading caused by the post-yield response of the A model. As a result of the analysis of this data and the data from associated smaller scale testing (references 8 and 5), the analytical expression for shear loading developed in the prediction report

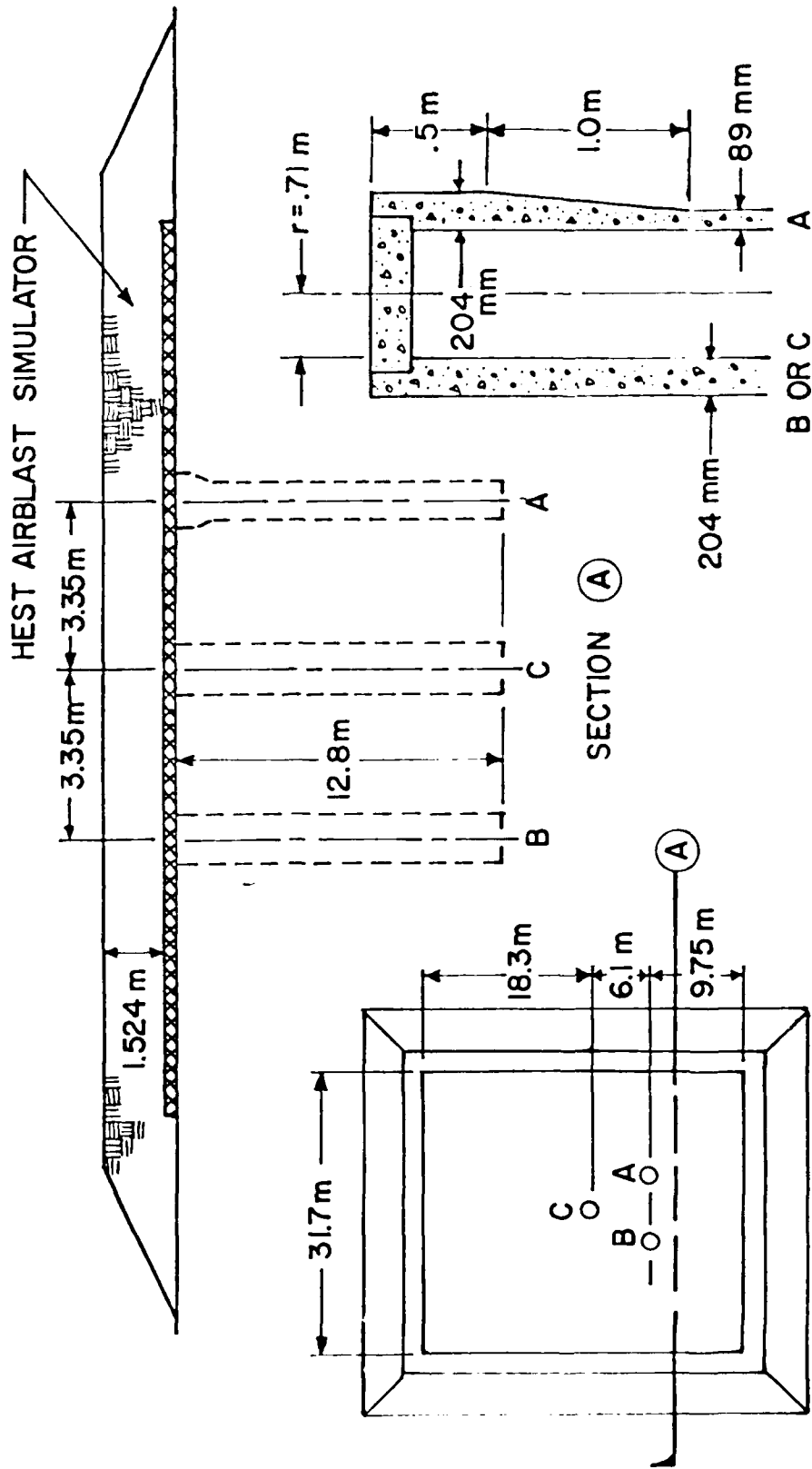

UPPER WALL DETAIL

PLAN VIEW

FIGURE 16. VERTICAL SHELTER TEST CONFIGURATION

(reference 25) was confirmed as adequate. The recommended formulation is:

$$\tau(t) = \rho c_s v(t); \quad \tau(t) \leq \tau_{\max}(t)$$

where: ρ = soil density

c_s = soil shear wave velocity

$v(t)$ = relative velocity at the soil-structure interface

parallel to the interface

$$= v_{\text{STR}}(t) - v_{\text{SOIL}}(t)$$

The shear stress calculated by this formulation is limited by the shear capacity of the soil and of the interface (τ_{\max}). The formulation of this failure surface is illustrated in figure 17 and represents an adaptation of an analytical and laboratory experimental study reported in reference 6. Analysis using this formulation represented the basic character of the loading observed experimentally although significant variations were observed. In general, the loading was well enough characterized to provide confident design and analysis procedures.

Considering only hardness against nuclear weapons effects, the vertical shelter clearly provided the best basing solution of the three concepts considered. However, as discussed previously a number of issues in addition to weapon effects survivability must be evaluated in the selection of a preferred basing mode. In late 1979, considerable attention was focused on Strategic Arms Limitations and verification of the number of strategic weapons was a major consideration. The Presidential decision was to adopt a Verifiable Horizontal Shelter Concept as the weapon system moved into its Full Scale Engineering Development phase.

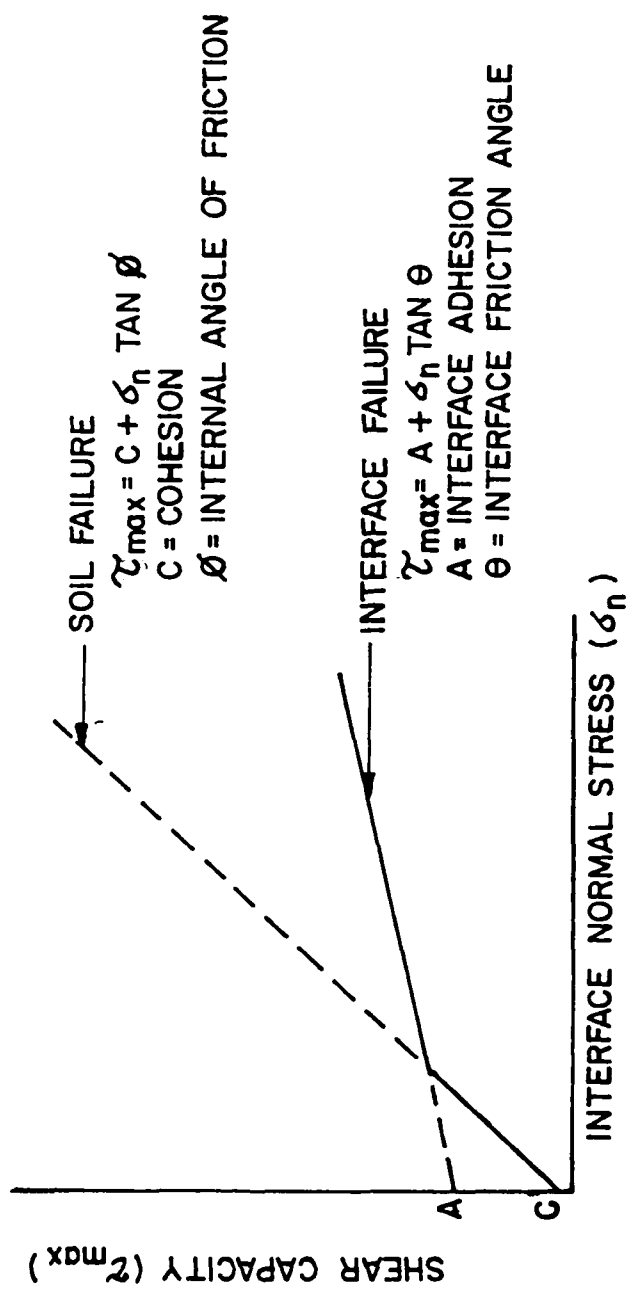

FIGURE 17. INTERFACE FAILURE SURFACE

SUMMARY

The large size testing of structural models associated with MX basing concepts played a major role in defining the expected loading and response modes. This data, in turn led to concept design revisions and was used to develop, refine and evaluate numerical analysis and assessment procedures. The large size testing was most valuable when it formed an integrated part of a combined program including structural component testing and numerical analysis. Both component test data and numerical calculations were essential for interpreting the complex behavior observed in the large size tests. In addition, the evaluation of analysis procedures provided the capability to more confidently adapt designs for siting or attack conditions not represented in the testing.

The major role of this combined testing and analysis program was to alter and refine preliminary design concepts. However, nuclear hardness and survivability considerations are only one of many factors that must be considered in selecting or changing basing concepts. The development of a modern weapons system such as MX involves commitment of significant national resources and influences our national and international policy. Technical considerations as well as political, must be viewed with this perspective.

APPENDIX I - REFERENCES

1. Belytschko, T., and Chiapetta, R. L., A Computer Code for Dynamic Stress Analysis of Media-Structure Problems with Nonlinearities (SAMSON), AFWL-TR-72-104, Air Force Weapons Laboratory, Kirtland AFB, NM, Feb 1973.

2. Bennett, B.W., "How to Assess the Survivability of U.S. ICBM's," R-2577-FF-R-2578-FF, Rand.Corporation, Santa Monica, CA, Jun 1980.
3. Bradshaw, J.C., "MX Trench Validation 90-day Study," Nuclear Technology Digest, AFWL-TR-78-110, Air Force Weapons Laboratory, Kirtland AFB, NM, Aug 1978.
4. Gagnon, L., Beason, J., and Click, F., Plug in Trench Simulation (PITS-1), AFWL-TR-78-145, Air Force Weapons Laboratory, Kirtland AFB, NM, May 1979.
5. Gran, J and Bruce, J., Small Scale Tests of MX Vertical Shelter Structures, SRI project 8176, SRI International, Menlo Park, CA, Apr 1980.
6. Huck, P., et al, Dynamic Response of Soil/Concrete Interfaces at High Pressure, AFWL-TR-73-264, Air Force Weapons Laboratory, Kirtland AFB, NM, Apr 1974.
7. Landon, G., et al, Dynamic Side-on Trench (DSOT) Tests, AFWL-TR-79-201, Air Force Weapons Laboratory, Kirtland AFB, NM, Nov 1979.
8. Landon, G., et al, Giant Reusable Airblast Simulator (GRABS) on Vertical Shelters (GOVS), AFWL-TR-80-157, Air Force Weapons Laboratory, Kirtland AFB, NM, May 1981.
9. Ma, C., et al, C-6 Wrap-up Study on Missile X Shelter Concept, AFWL-TR-79-23, Air Force Weapons Laboratory, Kirtland AFB, NM, Dec 1979.
10. Marquis, J.P., Static Trench/Plug Interaction Tests, AFWL-TR-79-8, Air Force Weapons Laboratory, Kirtland AFB, NM, Sep 1979.
11. Marquis, J.P., Dynamic Trench/Plug Interaction Tests, AFWL-TR-79-119, Air Force Weapons Laboratory, Kirtland AFB, NM, May 1980.
12. McNickle, P., et al, HAVE HOST Shelter Pretest Prediction and Quick-Look Report S-4, AFWL-TR-79-114, Vol IV, Air Force Weapons Laboratory, Kirtland AFB, NM, Feb 1981.
13. Morrison, D., et al, Analysis of HAVE HOST Event T-1, AFWL-TR-78-50, Air Force Weapons Laboratory, Kirtland AFB, NM, Jun 1979.
14. Morrison, D., et al, Analysis of HAVE HOST Event T-2, AFWL-TR-78-112, Air Force Weapons Laboratory, Kirtland AFB, NM, JUN 1979.
15. Morrison, D., et al, Analysis of HAVE HOST Event T-3, AFWL-TR-79-153, Air Force Weapons Laboratory, Kirtland AFB, NM, Sep 1980.
16. Morrison, D., and Bevacqua, M., Analysis of HAVE HOST Event T-5, AFWL-TR-80-84, Air Force Weapons Laboratory, Kirtland AFB, NM, Dec 1980.

17. Pickett, S., Development and Evaluation of a Triaxial Interface Stress Transducer, AFWL-TR-77-90, Air Force Weapons Laboratory, Kirtland AFB, NM, Aug 1977.
18. , Building Code Requirements for Reinforced Concrete (ACI 318-77), American Concrete Institute, Detroit Mich, Dec 1977.
19. , CONSTRUCTION JOINT TEST PROGRAM (FINAL REPORT), Karagozian and Case Structural Engineers, Los Angeles, CA, Jan 1973.
20. , HAVE HOST Trench Pretest Prediction and Quick-Look Report, Vol I, Event T-1, AFWL-TR-79-60, Vol I, Air Force Weapons Laboratory, Kirtland AFB, NM, Nov 1979.
21. , HAVE HOST Shelter Pretest Prediction and Quick-Look Report, Vol II, S-2 Event, AFWL-TR-79-114, Vol II, Air Force Weapons Laboratory, Kirtland AFB, NM, Mar 1980.
22. , HAVE HOST Trench Pretest Prediction and Quick-Look Report, Vol II, Event T-2, AFWL-TR-79-60, Air Force Weapons Laboratory, Kirtland AFB, NM, Jun 1980.
23. , HAVE HOST Trench Pretest Prediction and Quick-Look Report, Vol III, Event T-3, AFWL-TR-79-60, Vol III, Air Force Weapons Laboratory, Kirtland AFB, NM, Aug 1980.
24. , HAVE HOST Trench Pretest Prediction and Quick-Look Report, Vol IV, Event T-5, AFWL-TR-79-60, Vol IV, Air Force Weapons Laboratory, Kirtland AFB, NM, Mar 81.
25. , HAVE HOST Phase III, Vertical Shelter Test (VST) Pretest Prediction and Quick-Look Report, AFWL-TR-81-56, Air Force Weapons Laboratory, Kirtland AFB, NM, Aug 1981.
26. , A Review of MX Trench Testing Requirements, Headquarters, Defense Nuclear Agency, Washington, DC, Nov 1977.
27. , SALT II Agreement, Vienna, Jun 18, 1979, Department of State Publication 8984, General Foreign Policy Series 316, U.S. Government Printing Office, Washington, DC, 20402, (Stock Number 044-000-01749-1).
28. , SALT II and American Security, Revised Edition, Jun 1979, U.S. Government Printing Office, Washington, DC, 20402, (Stock Number 044-000-01744-0).
29. , "Special Report: Modernizing Strategic Forces," Aviation Week and Space Technology, Vol 112, No. 24, Jun 16, 1980, pp 56-290.

**DA
FILM**