

A130324

Best Available Copy

(1)

PHYSICAL MODELING TECHNIQUES FOR MISSILE  
AND OTHER  
PROTECTIVE STRUCTURES

Papers Submitted for Presentation During the  
American Society of Civil Engineers  
National Spring Convention  
Las Vegas, April 1982

Sponsored By the ASCE Engineering Mechanics Division  
Committee on Experimental Analysis and Instrumentation

Edited By: T. Krauthammer and C. D. Sutton

20030108168

DTIC  
ELECTE  
JUL 14 1983

A

This document has been approved  
for public release and sale; its  
distribution is unlimited.

83

02

023

004

AD A130324

UNFILE COPY



DEPARTMENT OF THE AIR FORCE  
HEADQUARTERS BALLISTIC MISSILE OFFICE (AFHQC)  
NORTON AIR FORCE BASE CALIFORNIA 94708

PA

29 Jun 83

Review of Material for Public Release

Mr. James Shafer  
Defense Technical Information Center  
DDAC  
Cameron Station  
Alexandria, VA 22314

The following technical papers have been reviewed by our office and are approved for public release. This headquarters has no objection to their public release and authorizes publication.

1. (BMO 81-296) "Protective Vertical Shelters" by Ian Narain, A.M. ASCE, Jerry Stepheno, A.M. ASCE, and Gary Landon, A.M. ASCE.
2. (BMO 82-020) "Dynamic Cylinder Test Program" by Jerry Stephens, A.M. ASCE.
3. (AFCMD/82-018) "Blast and Shock Field Test Management" by Michael Noble.
4. (AFCMD/82-014) "A Comparison of Nuclear Simulation Techniques on Generic MX Structures" by John Betz.
5. (AFCMD/82-013) "Finite Element Dynamic Analysis of the DCT-2 Models" by Barry Bingham.
6. (AFCMD/82-017) "MX Basing Development Derived From H. E. Testing" by Donald Cole.
7. (BMO 82-017) "Testing of Reduced-Scale Concrete MX-Shelters-Experimental Program" by J. I. Daniel and D. M. Schultz.
8. (BMO 82-017) "Testing of Reduced-Scale Concrete MX-Shelters-Specimen Construction" by A. T. Ciolko.
9. (BMO 82-017) "Testing of Reduced-Scale Concrete MX-Shelters-Instrumentation and Load Control" by N. W. Hanson and J. T. Julien. ✓
10. (BMO 82-003) "Laboratory Investigation of Expansion, Venting, and Shock Attenuation in the MX Trench" by J. K. Gran, J. R. Bruce, and J. D. Colton.

- 11. (BMO 82-003) "Small-Scale Tests of MX Vertical Shelter Structures" by J. K. Gran, J. R. Bruce, and J. D. Colton.
- 12. (BMO 82-001) "Determination of Soil Properties Through Ground Motion Analysis" by John Frye and Norman Lipner.
- 13. (BMO 82-062) "Instrumentation for Protective Structures Testing" by Joe Quintana.
- 14. (BMO 82-105) "1/5 Size VHS Series Blast and Shock Simulations" by Michael Noble.
- 15. (BMO 82-126) "The Use of Physical Models in Development of the MX Protective Shelter" by Eugene Sevin.
- \*16. REJECTED: (BMO 82-029) "Survey of Experimental Work on the Dynamic Behavior of Concrete Structures in the USSR" by Leonid Millstein and Gajanen Sabnis.

*Carol A. Schalkham*  
 CAROL A. SCHALKHAM, LTJ, USAF  
 Public Affairs Officer

Cy To: Dr. T. Krauthammer  
 Associate Professor  
 Department of Civil and  
 Mineral Engineering  
 University of Minnesota

Distribution For	
DTIC	<input checked="" type="checkbox"/>
DAK	<input type="checkbox"/>
Special	<input type="checkbox"/>
Availability Codes	
Dist	Special
A	



17 JAN 1982

TESTING OF REDUCED-SCALE CONCRETE MX-SHELTERS

INSTRUMENTATION AND LOAD CONTROL

KEY WORDS: Data systems; Deformations; Loads; Measuring instruments; Models; Pipes (tubes); Reinforced concrete; Shelters; Strains; Testing

ABSTRACT: Equipment and methods are described for application of axial load and non-uniform radial pressure to concrete specimens in constant strain rate tests. Forty-three specimens modeled candidate designs for horizontal MX-shelters. Loading combinations represented forces from nearby nuclear weapon attack. Servo-controlled hydraulic loading equipment and instrumentation were combined to apply specified loads and monitor both test performance and specimen behavior.

9 176 82 017

TESTING OF REDUCED-SCALE CONCRETE MX-SHELTERS

INSTRUMENTATION AND LOAD CONTROL

by

N. W. Hanson, M. ASCE, and J. T. Julien\*

An experimental program involving construction and testing of reduced-scale concrete Horizontal MX-Shelters was conducted by Construction Technology Laboratories, a Division of the Portland Cement Association. The program included 43 specimens tested under static loading conditions. Each specimen represented a "candidate design" being considered for prototype construction.

One deployment concept involved MX-missiles stored in underground horizontal shelters. One purpose of the shelter was to protect the missile from a nearby nuclear weapon attack such that the missile could be successfully launched after an attack. In the testing program, loads modeling combinations of forces that might occur from an attack were applied to the specimens. Loads consisted of axial thrust and non-uniform radial surface pressure. Data obtained from this test program were used to analyze shelter behavior under "known" loading conditions.

---

\*Respectively, Principal Structural Engineer, Structural Development Department, and Associate Construction Engineer, Construction Methods Section, Construction Technology Laboratories, a Division of the Portland Cement Association, Skokie, Illinois.

This is the last of three papers describing the program. Other papers describe Experimental Program<sup>(1)</sup> and Specimen Construction.<sup>(2)</sup>

### OBJECTIVES

Testing of the shelter model shown in Fig. 1 included application of selected combinations of axial thrust and radial pressures. Displacement control and data handling during testing are discussed in this paper. Objectives of instrumentation, test control, and data handling were:

1. Install sensors as necessary to provide data for control and for documentation of structural behavior.
2. Maintain a selected relationship between all loads while generating a monotonic increase in a measured displacement at a selected rate.
3. Measure and store data at 10 second intervals of time and display suitable reduced data at each interval for status check by test engineer.
4. Produce reduced data in the form of tables, charts, and digital tape for delivery to client within 24 hours of each test.
5. Provide semi-automatic instrumentation checkout and calibration procedures to allow two tests per day.

### INSTRUMENTATION

Measurements of strain, load, displacement, and time were recorded at intervals during the test for later analysis of results. Some measurements were also displayed on X-Y recorders

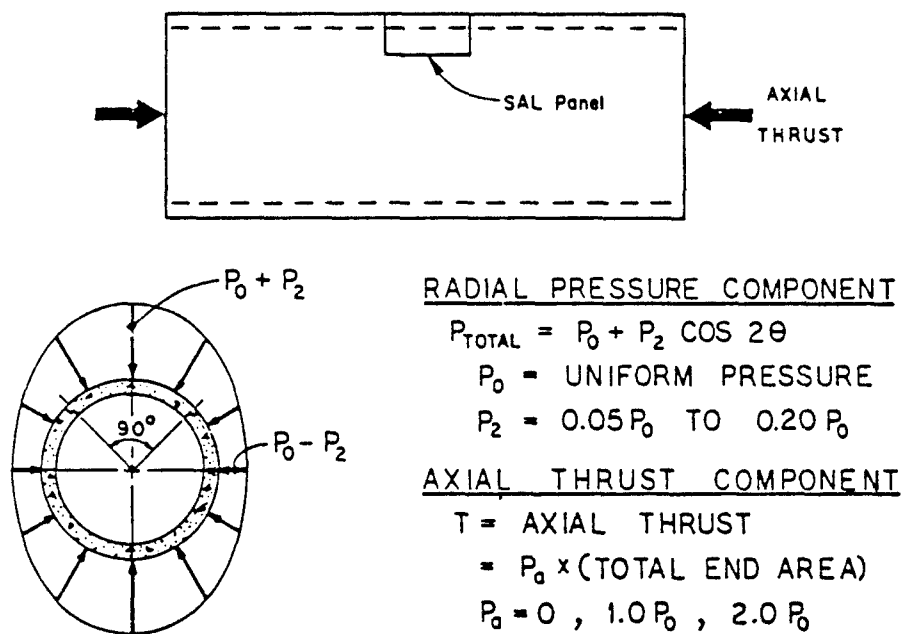

Fig. 1 Schematic of Test Specimen and Loading

for visual observation and verification of the test. Certain measurements were also used by the servo-controlled load system for test control. Table 1 lists types and locations of instrumentation. For reference purposes, specimens were positioned with their longitudinal axis vertical and with the SAL panel facing North.

A digital data acquisition system sampled all data items at about 10 second intervals during each test. Each sample was recorded at a rate of about 10 items per second. An average test had over 100 samples of data.

#### Longitudinal Strains

Axial change in length was sensed by linear potentiometers attached to the inner surface of the specimen. Measurements were made over a gage length of 50 in. (1.25 m). Potentiometers were spaced at quarter points around the inner circumference with one potentiometer centered on the SAL panel. Waters Model SLF-2 position transducers with 2-in. (50 mm) stroke were used for longitudinal strain measurements. Strain was calculated as axial length change divided by gage length.

#### Radial Displacements

Linear potentiometers were attached to the inner surface of each specimen to sense changes in diameter. Locations are given in Table 1. Two measurements on orthogonal diameters were made at each of two cross-sections. One cross-section was at mid-height with one diameter measurement centered on the SAL panel.

TABLE 1 - INSTRUMENTATION

Item	Description
<u>Longitudinal Strains</u> Potentiometer Potentiometer Potentiometer Potentiometer	Axial #1 - west side Axial #2 - east side Axial #3 - south side (opposite SAL) Axial #4 - at SAL Panel (north side)
<u>Radial Displacement</u> Potentiometer Potentiometer Potentiometer Potentiometer	Axial #1 - mid-height - north-south (SAL panel) Axial #2 - mid-height - east-west Axial #3 - above mid-height - north-south Axial #4 - above mid-height - east-west
<u>Radial Forces and Axial Load</u> Pressure Cell Pressure Cell Pressure Cell Pressure Cell	Radial load #1 - north-south (highest pressure) Radial load #2 - 4 places (intermediate pressure) Radial load #3 - east-west (lowest pressure) Axial ram
<u>Specimen Strains</u> 6 Strain gages 2 Strain gages 2 Strain gages 6 Strain gages 2 Strain gages 2 Strain gages	On circumferential reinf. at mid-height On radial reinforcement at mid-height On longitudinal reinforcement at mid-height On circumferential reinforcement above mid-height On radial reinforcement above mid-height On longitudinal reinf. above mid-height

The second measurement was 12 in. (300 mm) above mid-height. Waters Model SLF-6 position transducers with 6-in. (150 mm) stroke were used for radial displacement measurements.

#### Radial Forces

Radial surface pressures were applied by means of inflated pressure bladders pressing against zones on the specimen. Each zone was duplicated at symmetrical locations. Hydraulic pressure in each of the three zones was measured by a strain gaged pressure cell.

#### Axial Load

Force applied to axially compress the specimen was determined from a strain gaged pressure measuring cell. This cell sensed hydraulic pressure in the large axial load ram.

#### Specimen Strains

Strain gages were bonded on special small diameter steel rods or reinforcing steel embedded in the concrete of each test specimen. Strains were monitored at the 20 locations listed in Table 1.

#### Time

A digital clock in the data acquisition system provided a time reference for each data sampling.

#### Instrumentation Plan

Connections between sensors and instruments are shown in Fig. 2. Sensors, cables, and strain gage leads inside the specimen were connected to a junction box. Figure 3 shows the

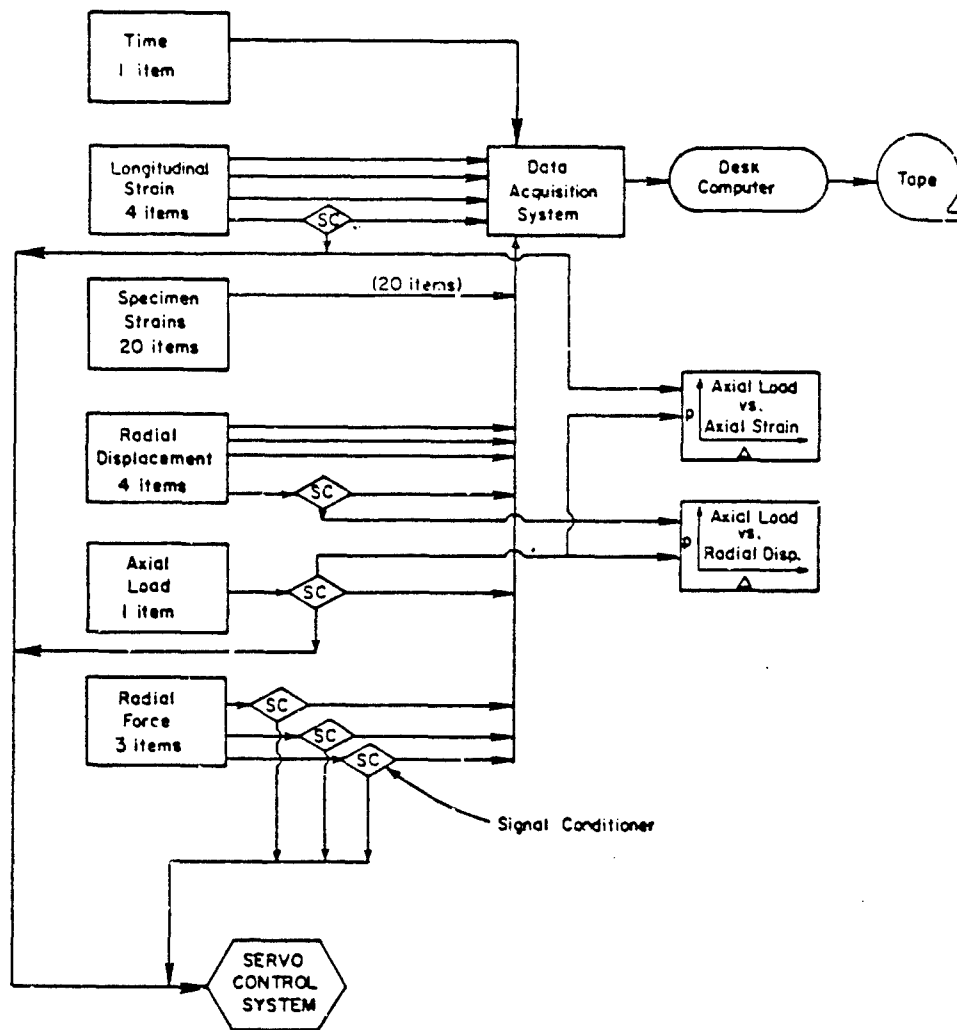

Fig. 2 Schematic of Data Acquisition System

Revision 1.0, December 1971, by J. H. ...

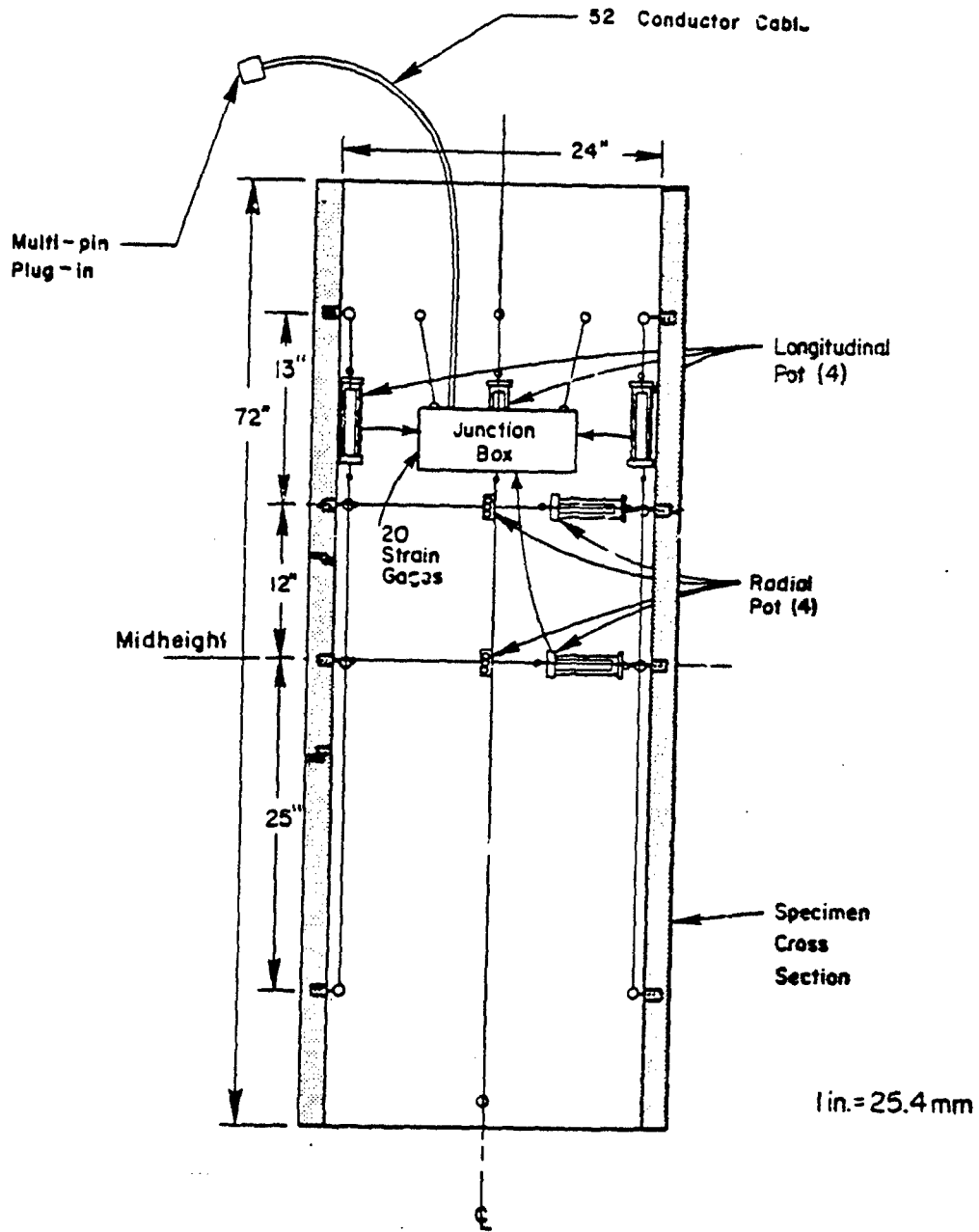

Fig. 3 Partial Instrumentation Layout

junction box with a short cable and multipin connector for attachment to the data acquisition system. All analog data were converted to digital data by a Hewlett-Packard Model 3052 Automatic Data Acquisition System. Digital information on each channel was stored on cartridge tape on a Hewlett-Packard Model 9845B desk computer.

#### LOAD CONTROL

The standard test involved application of combined uniaxial compression and radial surface pressure. In this configuration, radial load was applied as necessary to maintain a near constant rate of diameter deformation. Axial and radial loads were applied in proportions that developed the necessary  $P_a/P_o$  and  $P_2/P_o$  ratios.  $P_a$ ,  $P_o$ , and  $P_2$  are defined in Fig. 1. Closed loop electrohydraulic equipment by MTS Systems Corp. provided servo-control of loads.

The standard test at a constant rate of diameter deformation was conducted in about 30 minutes.

A schematic representation of load control is shown in Fig. 4. A radial displacement signal was manually compared to a predetermined ramp function to generate a control signal. This control signal was then used as program input to four MTS Model 406.11 Servo Controllers.

The combination of four individual closed loop servo-controlled loads within an overall closed loop incorporating manual rather than servo-control functioned well for these very slow tests. Using Servo-control in the outer loop tended to

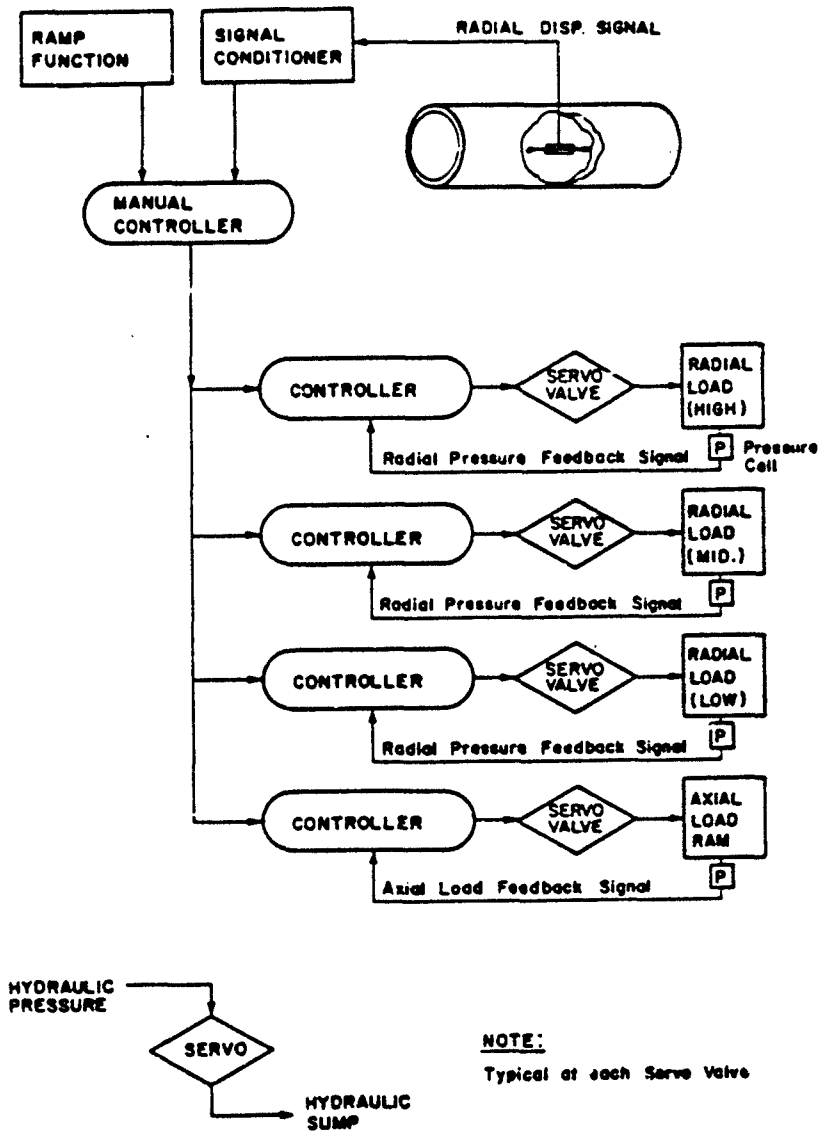

Fig. 4 Schematic of Load Control System for Standard Test

produce very low cycle oscillations (one cycle in 2 minutes) in the control circuit. Manual control was incorporated as a practical solution since the project schedule did not allow time for the experimentation needed to otherwise solve the problem.

The feedback signal for each controller came from a pressure cell, BLH type DHF, at each radial loading assembly and at the axial ram. Each controller compared the feedback signal to the program input signal to generate a control signal that operated a servo valve in the loading system. An MTS Model 252.22 Servo Valve controlled hydraulic pressure applied to high, middle, and low pressure loading assemblies, and to the axial ram. These valves, which had flow rates of 2.5 gallons (9.5 L) per minute, were matched to required flow rates to minimize load pulsations.

A predefined relationship was maintained between radial pressures in the three zones and axial load. Adjustment of each controller set the proportionality factor between radial pressures and axial load.

The preceding description applied to the standard test which included both axial and radial load. When only radial load was applied, program input on the axial load controller was set to zero. For tests of axial load only, program input on the three radial load controllers was set to zero. Axial load tests were based on constant rate of axial strain rather than diameter deformation.

#### DATA HANDLING

As a test progressed, data items were sequentially connected by the scanner to a digital voltmeter that measured voltage and

sent voltage data to the computer. The 32 data items plus time were measured in an elapsed time of about 3 seconds at intervals of 10 seconds. The computer stored each 10-second data as a record in a random access file on magnetic tape. Data were then reduced to engineering units and ratios for presentation on the screen of the HP9845B computer. Since the test specimen was completely hidden from view during a test, the test engineer had to judge conduct of the test from the constantly updated data display. An example of a screen display of data is shown in Fig. 5.

#### Data Reduction

After each test, data files on tape were read into the computer for reduction to engineering units and plots. Tables of data were printed and relationships between variables were plotted. An example of a table and a plot are shown in Figs. 6 and 7 respectively. The data files on a raw data tape for a test included descriptive information concerning the test, zero readings on all items, calibration factors, and data records for each time interval. A reduced data tape was made for the client. That tape included descriptive information and data records prepared in engineering units. A package of tables, plots, and tape, such as shown in Fig. 8, was sent to the client within 24 hours of each test.

An additional improvement in the reduced data was made for the final report. In tests that included non-uniform radial load, there were data points in which the load ratio  $P_2/P_0$  deviated from the specified ratio. Final reduced data included only those points with the ratio of  $P_2/P_0$  within  $\pm 10\%$  of the specified ratio.

```

FINISHED WITH LINE 92          AT 14 42 48

AXIAL LOAD= 298                PA/P0=+1.001      LOAD STAGE# 92
RADIAL PRESS HIGH= 541         ,P2/P0=+0.098
RADIAL PRESS MID= 497
RADIAL PRESS LOW= 454         ,P2/P0=+0.096

STR GAGES      Midheight      Upper
Outer Circum+0.970693 North -0.001606
Inner          -0.000109
Outer          +0.000517 West  +0.000680
Inner          -0.000126
Outer          -0.000713 45 Deg -0.001864
Inner          +0.000110
                -0.000496

Near Radial +0.000389 45 Deg+0.000269
Far          +0.000871              +0.000296

Outer Longit+0.001233 North +0.000053
Inner        +0.000491              -0.000039

AXIAL STRAIN
North (SAL)
-0.000851

West +0.000529 +0.000490 East
-0.000459
South

RADIAL DISPLACEMENT (in)
Midheight
North-South -0.687 Upper
East-West   +0.502 -0.586
+0.495

```

Fig. 5 Data Display on HP 9845B Computer Screen.

LOAD STAGE	AXIAL STRAIN WEST (IN/IN)	AXIAL STRAIN EAST (IN/IN)	AXIAL STRAIN SOUTH (IN/IN)	AXIAL STRAIN NORTH (IN/IN)	FRI. DEFL. GAL. #5 (INCHES)
1	-0.00001	-0.00000	-0.00000	-0.00001	-0.000
2	-0.00001	-0.00001	-0.00001	-0.00001	-0.001
3	-0.00002	-0.00002	-0.00001	-0.00005	-0.002
4	-0.00004	-0.00003	-0.00005	-0.00010	-0.003
5	-0.00006	-0.00005	-0.00006	-0.00015	-0.004
6	-0.00009	-0.00009	-0.00009	-0.00020	-0.005
7	-0.00014	-0.00013	-0.00014	-0.00027	-0.006
8	-0.00019	-0.00017	-0.00018	-0.00034	-0.007
9	-0.00023	-0.00021	-0.00022	-0.00039	-0.008
10	-0.00027	-0.00024	-0.00025	-0.00043	-0.009
11	-0.00030	-0.00027	-0.00028	-0.00047	-0.010
12	-0.00034	-0.00029	-0.00031	-0.00050	-0.010
13	-0.00036	-0.00032	-0.00034	-0.00054	-0.011
14	-0.00039	-0.00034	-0.00037	-0.00057	-0.011
15	-0.00042	-0.00037	-0.00041	-0.00060	-0.012
16	-0.00045	-0.00039	-0.00043	-0.00063	-0.013
17	-0.00047	-0.00042	-0.00046	-0.00066	-0.013
18	-0.00050	-0.00044	-0.00049	-0.00069	-0.014
19	-0.00053	-0.00046	-0.00052	-0.00072	-0.015
20	-0.00056	-0.00049	-0.00055	-0.00075	-0.016
21	-0.00059	-0.00051	-0.00058	-0.00079	-0.016
22	-0.00061	-0.00053	-0.00061	-0.00082	-0.017
23	-0.00064	-0.00057	-0.00065	-0.00085	-0.018
24	-0.00067	-0.00060	-0.00068	-0.00088	-0.019
25	-0.00070	-0.00062	-0.00071	-0.00091	-0.019
26	-0.00073	-0.00065	-0.00074	-0.00094	-0.021
27	-0.00076	-0.00067	-0.00078	-0.00098	-0.021
28	-0.00079	-0.00070	-0.00081	-0.00101	-0.022
29	-0.00081	-0.00072	-0.00083	-0.00104	-0.023
30	-0.00084	-0.00075	-0.00086	-0.00107	-0.023
31	-0.00087	-0.00077	-0.00089	-0.00110	-0.025
32	-0.00090	-0.00081	-0.00092	-0.00113	-0.027
33	-0.00092	-0.00084	-0.00097	-0.00116	-0.028
34	-0.00095	-0.00086	-0.00099	-0.00119	-0.029
35	-0.00098	-0.00089	-0.00103	-0.00122	-0.030
36	-0.00100	-0.00091	-0.00106	-0.00125	-0.031
37	-0.00103	-0.00094	-0.00110	-0.00128	-0.032
38	-0.00106	-0.00097	-0.00113	-0.00131	-0.033
39	-0.00109	-0.00100	-0.00117	-0.00135	-0.034
40	-0.00111	-0.00102	-0.00120	-0.00137	-0.035
41	-0.00114	-0.00105	-0.00123	-0.00140	-0.035
42	-0.00117	-0.00108	-0.00125	-0.00142	-0.036
43	-0.00119	-0.00111	-0.00129	-0.00144	-0.037
44	-0.00122	-0.00114	-0.00132	-0.00146	-0.037
45	-0.00125	-0.00116	-0.00136	-0.00151	-0.038
46	-0.00128	-0.00119	-0.00139	-0.00154	-0.039
47	-0.00130	-0.00121	-0.00143	-0.00156	-0.039
48	-0.00133	-0.00124	-0.00147	-0.00160	-0.041
49	-0.00136	-0.00127	-0.00150	-0.00162	-0.041
50	-0.00139	-0.00129	-0.00153	-0.00165	-0.042
51	-0.00141	-0.00133	-0.00156	-0.00167	-0.042
52	-0.00144	-0.00135	-0.00159	-0.00170	-0.043
53	-0.00147	-0.00137	-0.00163	-0.00173	-0.044
54	-0.00150	-0.00140	-0.00166	-0.00176	-0.044
55	-0.00153	-0.00143	-0.00169	-0.00177	-0.045
56	-0.00155	-0.00145	-0.00173	-0.00180	-0.046
57	-0.00158	-0.00148	-0.00176	-0.00183	-0.046
58	-0.00160	-0.00151	-0.00180	-0.00186	-0.047

Fig. 6 Data Table.

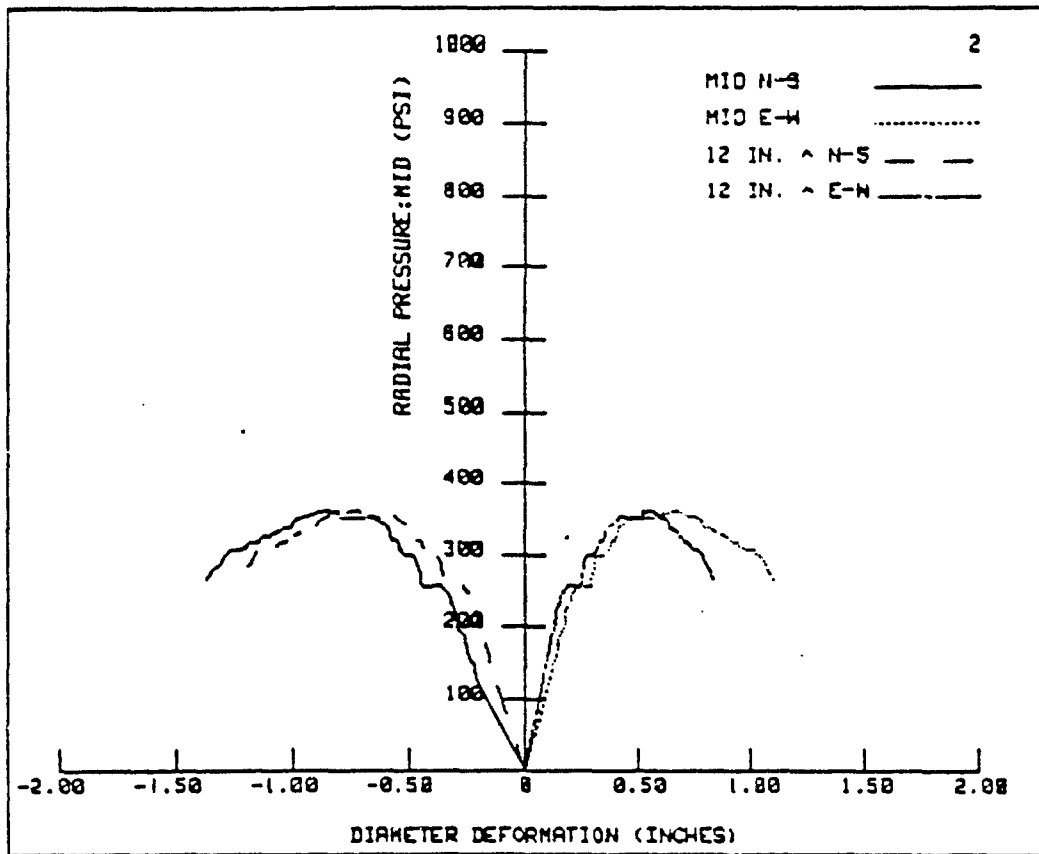

RADIAL PRESSURE (MID) VS DIAMETER DEFORMATION

Metric Equivalent: 1 psi = 6.9 kPa  
 1 in. = 25.4 mm

Fig. 7 Data Plot.



Fig. 8 Data Package.

Each test started from zero load and pressure so it was difficult to develop data within the specified ratio limits early in the test. Valid data points were joined by straight lines on graphs showing relationships.

#### CALIBRATIONS

The computer and data acquisition system were utilized during check-out of instrumentation before a specimen was placed in the test rig. At that time, the junction box was connected and a recording of data was made to check that all strain gages were connected. Open or short circuits not previously assigned to gage failure were corrected. Repeated recordings of data were used to check stability of each gage. Drifting gages, not previously noted to have low resistance to ground, indicated poor connections that could be corrected. Similar checks of potentiometers revealed continuity, initial stroke settings, and stability. Two complete sets of potentiometers and junction boxes were used to allow specimen instrumentation and checkout to be completed prior to test time.

After a specimen was installed in the test rig, the junction box shown in Fig. 3 was again connected to the system. Screen display on the computer was used to prompt successive steps in calibration and adjustment needed to prepare for a test.

Power supply voltage to the junction box was read and compared with a specified value automatically. If adjustment was needed, prompts on the screen helped the technician make the adjustment. A similar bridge voltage check and adjustment was made on a standard voltage in the M.T.S. control equipment.

Pressure cells at the axial load hydraulic ram and in the hydraulic connection to the three zones of radial pressure were calibrated by shunt resistors inserted manually from the console. On prompt from the computer, the four calibrations were made and bridge voltage adjusted.

The initial output of each displacement potentiometer was set to zero by adjustment on the console. Prompts from the computer guided the zero adjustment sequence. Total preparation for test using these prompts from the computer was completed in about 10 minutes.

#### SUMMARY

Instrumentation and load control were used to meet the objectives for testing reduced scale concrete MX-Horizontal Shelters. Details of instrumentation, load control, data handling, and calibrations are presented.

#### ACKNOWLEDGMENTS

This investigation was sponsored by Karagozian & Case, Structural Engineers, Los Angeles, California under contract to Ballistic Missile Office, Norton Air Force Base, MNNXH, San Bernardino, CA. Ralph Leistikow was Principal in Charge for the sponsor. Work was conducted in the Structural Development Department, Dr. H. G. Russell, Director, as part of the contract research activities of the Construction Technology Laboratories, a Division of the Portland Cement Association. Mr. D. M. Schultz, Assistant Manager, Structural Development Department, was Principal Investigator.

#### REFERENCES

1. Daniel, J. I., and Schultz, D. M., "Testing of Reduced-Scale Concrete MX-Shelters - Experimental Program," Paper submitted to ASCE Committee on Experimental Analysis and Instrumentation, January 1982.
2. Ciolko, A. T., "Testing of Reduced-Scale Concrete MX-Shelters - Specimen Construction," Paper submitted to ASCE Committee on Experimental Analysis and Instrumentation, January 1982.

PCA R/D Ser. No. 1695