

729

ADA 130384

3301

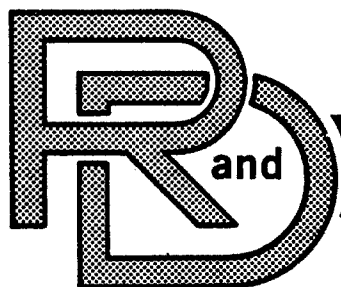

CENTER

LABORATORY

TECHNICAL REPORT

NO. 12593

LIGHTWEIGHT COMPOSITE
TOW BAR

Contract Number DAAK30-79-C-0111
June 1981



Robert Adkinson
Exxon Enterprises
Greer, South Carolina 29651
And

T. Wassel, D. Ostberg & M. Holly
US Army Tank Automotive Command
ATTN: DRSTA-RCKM
Warren, MI 48090

by _____

Approved for Public Release:
Distribution Unlimited.

U.S. ARMY TANK-AUTOMOTIVE COMMAND
RESEARCH AND DEVELOPMENT CENTER
Warren, Michigan 48090

20030908025

NOTICES

The findings in this report are not to be construed as an official Department of the Army position.

Mention of any trade names or manufacturers in this report shall not be construed as advertising nor as an official indorsement or approval of such products or companies by the US Government.

Destroy this report when it is not longer needed. Do not return to the originator.

20. ABSTRACT Cont.

The fabricated tow bars were tested at Aberdeen Proving Ground in order to obtain a safety release. Although a safety release was not obtained, the concept demonstration of a lightweight composite tow bar was proven feasible. A modified tow bar with higher temperature capability adhesive will be fabricated in a follow on program. Results of the APG tests are listed in APG report no. APG-MT-5578.

SUMMARY

The lightweight composite tow bar program, under contract number DAAK-30-79-C-0111, was to demonstrate the producibility of a tow bar, made with a composite of materials, weighing only 125 pounds (56.7 kg). The current metallic tow bar weighs approximately 340 pounds (154.2 kg.). If producible, a composite material 125 pound tow bar would facilitate tow bar use, and require fewer personnel for deployment.

We produced two tow bars, each weighing slightly less than 125 pounds, with steel fittings and attaching hardware.

The US Army Tank-Automotive Command (TACOM), in September, 1979 granted authorization for the preliminary design phase. One production design composite tube was delivered to TACOM for laboratory testing. In March, 1980 TACOM approved the design and requested the fabrication of prototype tow bars. Two tow bars were delivered in December, 1980.

The prototype tow bar is 83-1/2 inches (2121 mm) long from eye to eye; this does not include the clevis fittings. Figure 1 shows the finished tow bar just before their shipment to the Army. Note in the photograph that the prototype tow bar is similar in outward appearance to the current metallic tow bar. The big difference is that the metallic tow bar weighs approximately 340 pounds compared to the approximate weight of 125 pounds for the composite one.

By using composite materials, a lightweight tow bar has been fabricated which meets the requirements specified in the contract. Field testing, which is to follow, will be used to validate both the concept and the design.

TABLE OF CONTENTS

<u>SECTION</u>		<u>PAGE</u>
	SUMMARY.....	2
1.0	INTRODUCTION.....	6
2.0	DESIGN DISCUSSION	
2.1	<u>Design Criteria</u>	9
2.2	<u>Material Considerations</u>	10
2.2.1	<u>The Composite Tubes</u>	10
2.2.2	<u>The Metal Fittings</u>	15
2.2.3	<u>Adhesive Material Selection</u>	15
2.3	<u>Tow Bar Design</u>	15
2.3.1	<u>Composite Tube Design</u>	15
2.3.2	<u>Design of the Metal Parts</u>	18
2.3.3	<u>Adhesive Joint Design</u>	24
3.0	ANALYSIS.....	30
3.1	<u>Finite Element Analysis of the Adhesive Joint</u>	30
3.2	<u>Tow Bar Analysis by Component</u>	54
3.2.1	<u>Composite Tube Analysis</u>	55
3.2.2	<u>Steel Sleeve</u>	57
3.2.3	<u>Weld Joint</u>	57
3.2.4	<u>Eye</u>	58
3.2.5	<u>Lunette</u>	59
3.2.6	<u>Clevis</u>	60
4.0	FABRICATION.....	69
4.1	<u>Metal Fittings</u>	69
4.2	<u>Composite Tube</u>	69
4.2.a	<u>Kevlar Sheath</u>	69
4.2.b	<u>Graphite/Epoxy Tube</u>	69
4.3	<u>Weld Assembly</u>	75
4.4	<u>Final Assembly</u>	76
5.0	TESTING.....	77
5.1	<u>Material Testing</u>	77
5.1.a	<u>Graphite/Epoxy</u>	77
5.1.b	<u>Adhesive</u>	77
5.2	<u>Joint Tests</u>	78
5.3	<u>Design Verification</u>	79
5.4	<u>Non-Destructive Testing</u>	79
5.5	<u>Field Testing</u>	80
ADDENDUM.....		81
DISTRIBUTION LIST.....		114

LIST OF ILLUSTRATIONS

FIGURE	TITLE	PAGE
1	Composite Tow Bar.....	8
2-5	Tow Bar Tube Design Curves.....	12, 13
6	Kevlar Sheath.....	17
7	Towing Lunette.....	19
8	Lunette Eye.....	21
9	Lunette Clevis/Lugs.....	22
10	Sleeve.....	23
11	Lunette - Cross - Section.....	25
12, 13	Shear and Normal Stresses.....	26, 27
14, 15-32	Finite Element Models.....	30, 32-53
33	Loading Geometry.....	54
34	Cross - Section, Tube.....	56
35, 37	Eye.....	58, 60
36	Lunette.....	59
38-42	Clevis.....	63-67
43	Composite Tube Manufacturing Sequence.....	71
44	Sheath.....	73
45	Unidirectional Prepreg.....	74

LIST OF TABLES

TABLES	TITLE	PAGE
1	Unidirection Composite Material Static Design Allowables.....	11

1.0 INTRODUCTION

Within the Tank-Automotive Command Research and Development Center's assigned mission is the responsibility for evaluating new materials and concepts which might relate to the Army's needs. The Lightweight Tow Bar Program evaluates the concept of a carry-along tow bar for battlefield recovery vehicles and the utilization of composite materials for vehicular applications.

Exxon Enterprises Materials Division (EEMD) was selected to develop the Lightweight Tow Bar (LTB) design through proposal competition. The LTB program will demonstrate the application of advanced organic composite materials on a current army inventory component, namely, the heavy duty tow bar.

Reducing the weight of battlefield equipment is viewed as necessary. A lightweight tow bar will benefit the Army in several ways. The LTB will be less difficult to handle and install on a vehicle, hence fewer personnel and less time will be needed when use of a tow bar is necessary.

The lightweight tow bar developed under this contract weighs 125 lb (56.7 Kg), as opposed to 340 lb (154 Kg) for the metal tow bar, thus meeting the program objective. The LTB is designed to be stowable on the M60 series and Abrams (MI) vehicles. Its basic configuration, installation, and function are identical with the currently inventoried steel tow bar (P/N 8383802). The legs, or tubes, of the LTB are fabricated from high strength graphite fiber-reinforced epoxy. These structural members are protected by an overwrap of Kevlar material. This arrangement yields a lightweight tube in which the structural component is shielded by a proven lightweight protection system.

Prior to actual prototype fabrication, a detailed analysis was made of all component parts of the tow bar, based on loads encountered under operational conditions. Next, material tests were performed on the composite components to verify their properties. Comparative tests were conducted on adhesives to determine the best system for bonding the metallic fittings to the composite tubes. Specimens of a preliminary joint design (which closely resembled the final design) were made and tested. These tests verified the design of the joint, while pointing out a need for a slight adjustment of the lay-up sequence of the original laminate.

A finite element model of the joint between the composite tube and the metallic fittings was constructed to verify the design. All of the analyses and tests were used to verify or adjust the final design.

These initial efforts lead to fabrication of a first LTB article to the final configuration. This first article was made with production materials, tools, and personnel. Fabrication of this tow bar was completed without problems, and was shipped to TACOM for testing.

Tests by TACOM personnel verified the design, and the go-ahead was given for prototype production. After fabrication, the composite tow bars were C-scanned, revealing well-developed laminates with no detectable internal flaws.

The metallic elements of the design were of high-strength alloy steel. Metal sleeves were adhesively bonded to the ends of the composite tubes. End fittings were subsequently welded to the sleeves by gas-metal arc welding (GMAW). After welding, the tow bars were painted forest green and were delivered to TACOM for further field vehicle testing.

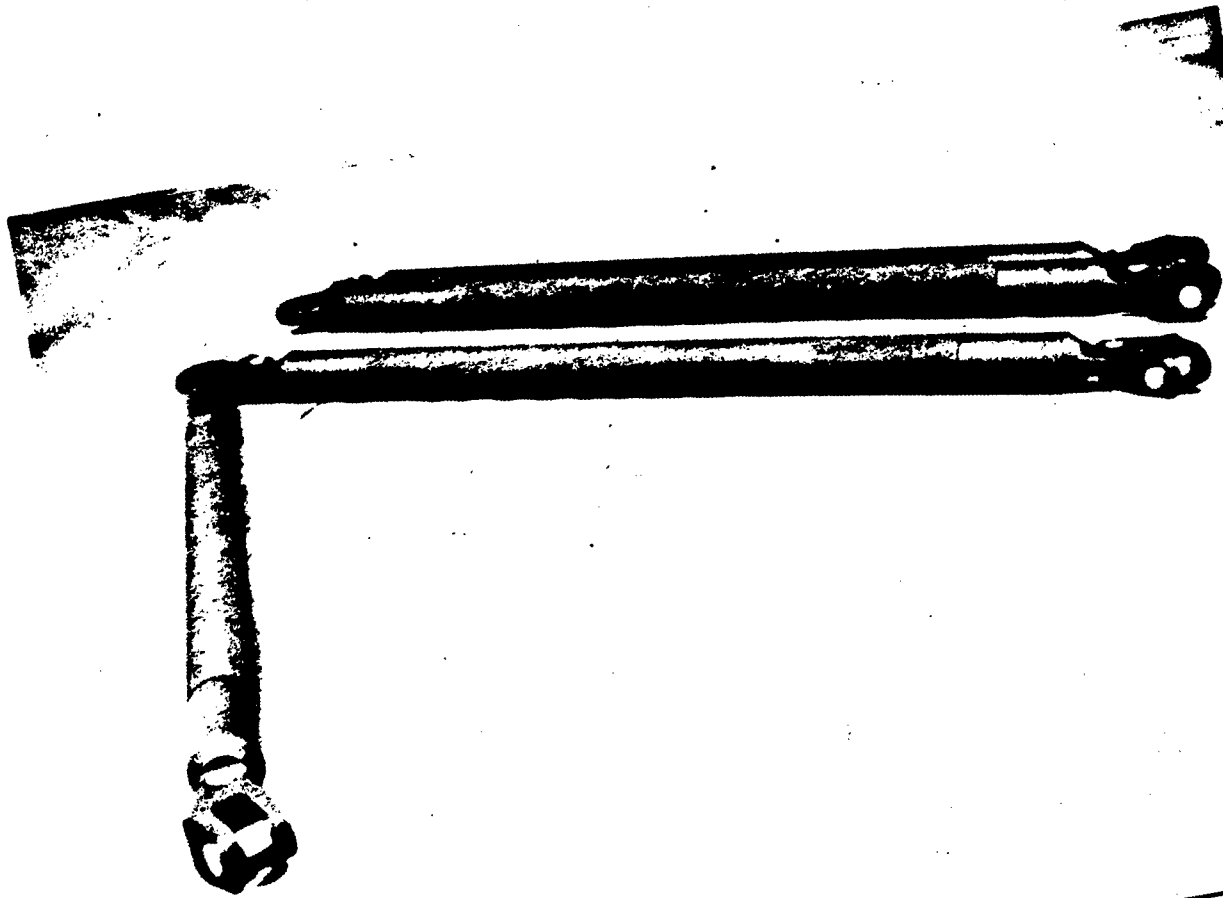

FIGURE 1 — Composite Tow Bar

2.0 DESIGN DISCUSSION

The overall design of the tow bar was specified. Primary consideration of the design was to meet low weight requirements and towed vehicle to towing vehicle geometry requirements. The requirements which the prototype tow bars met are discussed in para 2.1 below. Sections 2.2 thru 2.3 discuss how the materials and the design configuration were chosen.

2.1 Design Criteria

- Material: The tow bar is to utilize composite materials in its design.

High strength graphite fiber reinforced epoxy was selected as the stress-bearing material. The stress-bearing members are provided with a Kevlar/epoxy protective overwrap.

- Weight: The weight of the tow bar shall not exceed 125 lb (56.7 kg).

The actual weights of the prototype tow bars, including all metallic fittings, were 124.3 and 124.5 lb.

- Stowability: The tow bar shall be stowable on the Abrams (M1) main battle tank.

Appendix A includes a drawing for the stowage of the tow bar on the M1 tank.

- Strength Requirements: The tow bar shall be capable of withstanding a 130,000 pound (578269 newton) load, in tension and compression, for a straight pull and push with a 180° angle between the vehicles with the tow bar in the deployed condition.

The tow bar analyses and tests to date indicate a capability exceeding the requirements given above.

- Dimensional Requirements: Similar in size - not to exceed the existing metallic tow bar dimensions.

The overall length from lunette eye to opposite eye of 83-1/2 inches for the composite and metallic tow bars is identical and the tow bars may be dimensionally interchangeable.

- Environment: The tow bar must be resistant to nominal damage or environmental degradation.

The Kevlar sheath which protects the high strength graphite/epoxy composite tube fulfills the environmental requirements.

2.2 Material Considerations

2.2.1 The Composite Tubes. The composite tubes used in the prototype tow bars are made from high strength graphite/epoxy, and have an external (outside) diameter of 4-1/4 inches. The properties of high strength graphite/epoxy, as well as other candidate materials, are shown in Table 1.

The weight versus diameter curves shown in Figures 2, 3, 4 and 5 best illustrate how the material was selected and how the optimum weight/diameter compromise was arrived at. Figure 3 illustrates the weight versus tube diameter (i.e., outside diameter) curves for high strength graphite/epoxy tubes with a length of 83-1/2 inches (2121 mm). For every value of tube diameter, there is a minimum weight of high strength graphite/epoxy material required for an 83-1/2 inch-long tube to meet the compressive strength, tensile strength, Euler (column) buckling strength, and cylindrical (wall) buckling strength requirements at the specified load conditions.*

*The tow bar is designed to transmit 130,000 lb (58968 kg, or 578269 newtons) in tension or compression. The geometry of the tow bar is such that each composite tube transmits 72631 lb (32945 kg, or 323079 newtons) under design load conditions. See Section 3.2.

	GRAPHITE/EPOXY		FIBERGLASS		ARAMID
	HIGH STRENGTH	HIGH MODULUS	S-GLASS	E-GLASS	
LONGITUDINAL MODULUS, MSI	18.0	24.0	7.1	5.4	11.0
TRANSVERSE MODULUS, MSI	1.5	1.1	1.4	1.2	0.8
SHEAR MODULUS MSI	0.60	0.65	0.55	0.66	0.3
POISSON RATIO	0.20	0.21	0.25	0.25	0.34
LONGITUDINAL STRENGTH, KSI TENSILE COMPRESSIVE	160.0 135.0	90.0 80.0	172.0 76.0	128.0 72.0	160.0 32.0
TRANSVERSE STRENGTH, KSI TENSILE COMPRESSIVE	6.4 13.5	3.2 16.0	7.0 20.8	2.5 16.0	3.4 16.0
SHEAR STRENGTH, KSI	8.0	6.0	5.6	5.6	7.0
DENSITY, lb/in ³	0.06	0.06	0.073	0.073	0.05

TABLE 1 — Typical Unidirectional Composite Material Static Design Allowables

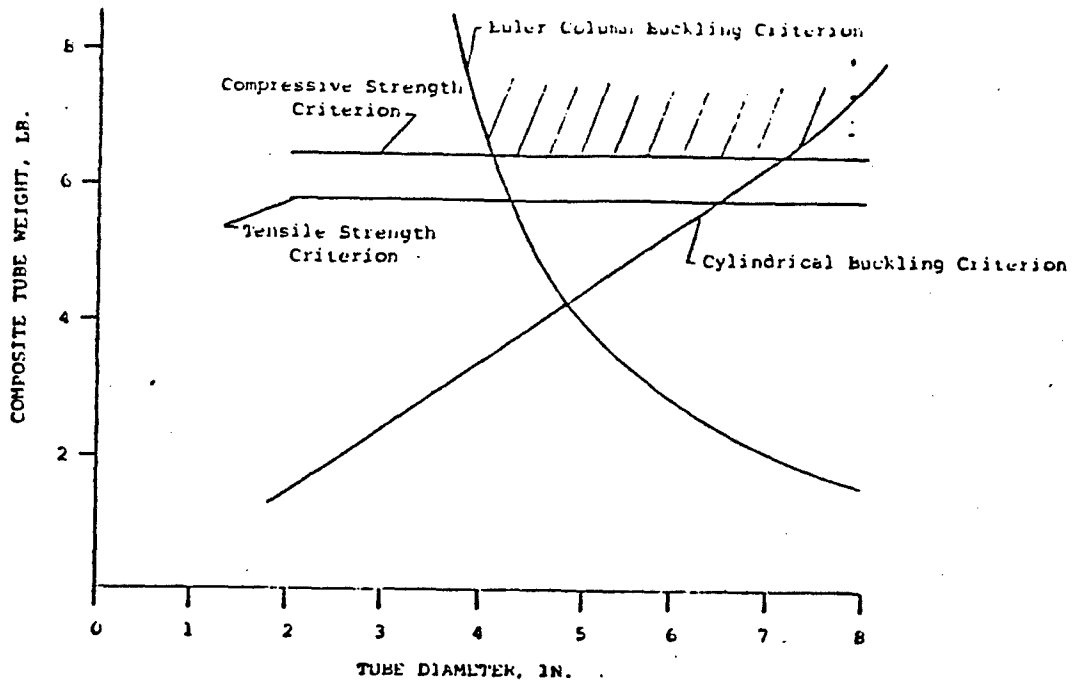

FIGURE 2 — Tow Bar Tube Design Curves - High Modulus Graphite/Epoxy

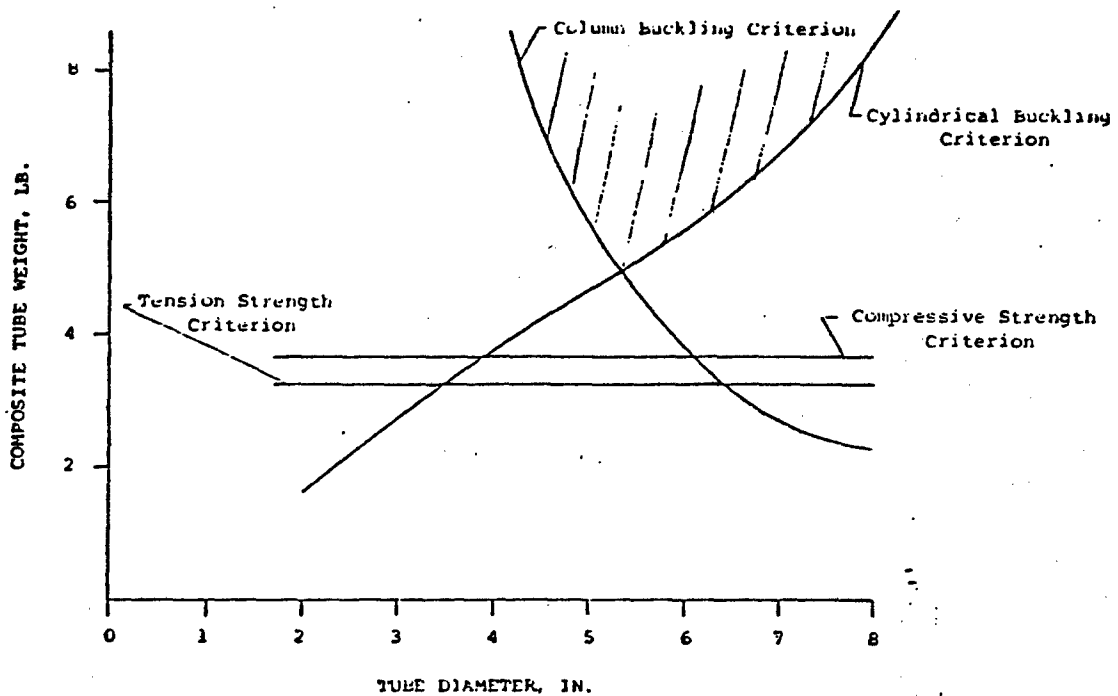

FIGURE 3 — Tow Bar Tube Design Curves - High Strength Graphite/Epoxy

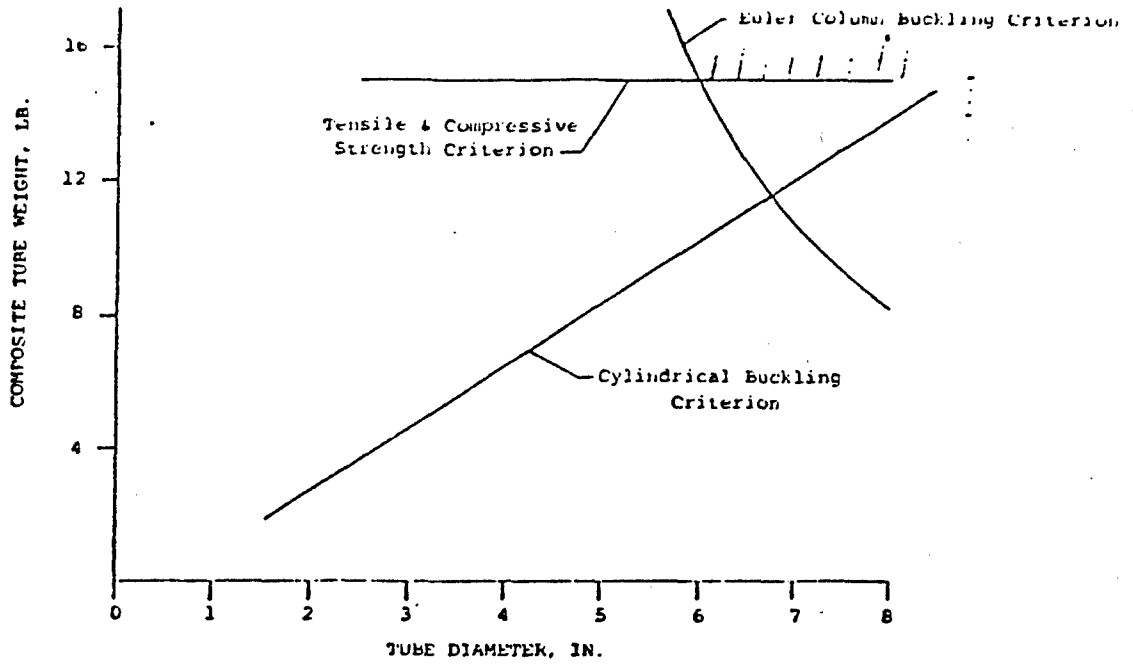

FIGURE 4 — Tow Bar Tube Design Curves - E-Type Fiberglass/Epoxy

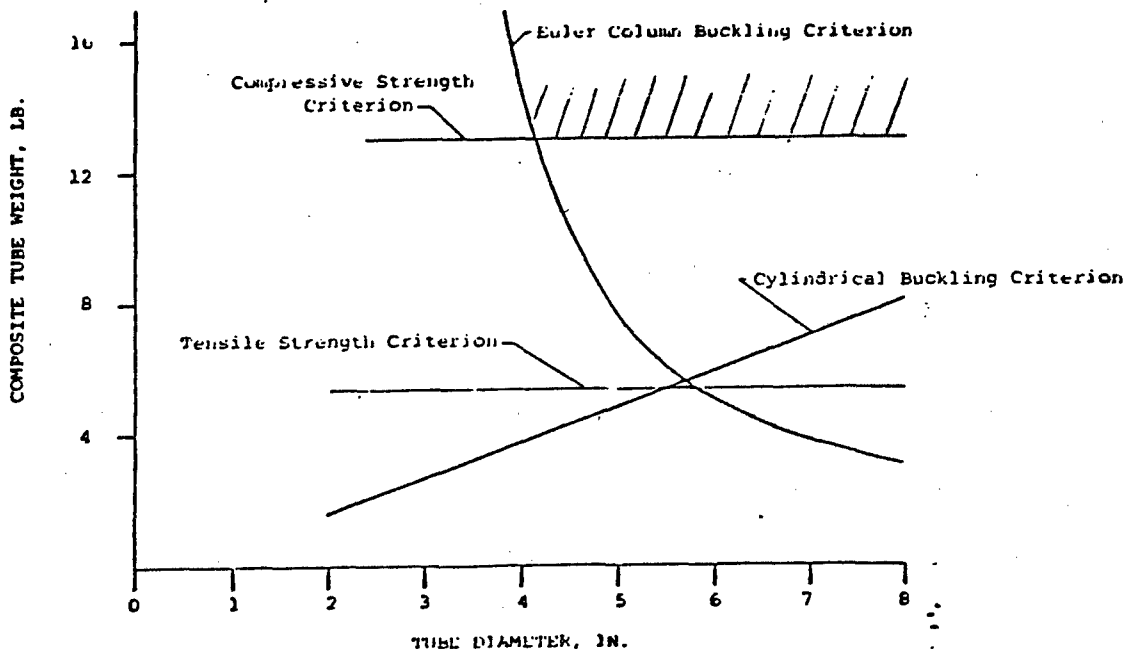

FIGURE 5 — Tow Bar Tube Design Curves - Aramid/Epoxy

From a study of the four minimum weight versus tube diameter curves shown in Figure 3, it can be shown that a diameter somewhat greater than 5 inches (127 mm) can meet all four criteria with a lower weight of material than tubes of the same material with lesser or greater diameters. However, a tube with this diameter would be difficult to handle and, in addition, would be more susceptible to accidental damage than a tube that is smaller in diameter. Therefore, 4-1/4 inches (108 mm) was chosen as the most suitable diameter. A high strength graphite/epoxy tube so designed weighs about 8 lb (3.63 kg), which is more than the weight of a tube of the same material at the optimum diameter. However, if enough material is used to meet the Euler buckling criteria, the tube will exceed the minimum requirements regarding compressive strength, tensile strength, and cylindrical buckling strength.

Figures 2, 4, and 5 are minimum weight versus tube diameter plots for high modulus graphite/epoxy, E-type fiberglass/epoxy, and Aramid fiber/epoxy, respectively. As with Figure 3, each of these figures shows four curves representing, for each value of tube diameter, the minimum weight of the given material required for an 83-1/2 inch-long tube to meet the four aforementioned strength criteria when subjected to the design load. Note that for high modulus graphite/epoxy, a 4-1/4 inch diameter tube using somewhat more than 6 lb (2.72 kg) of material will meet all four strength criteria with compressive strength being the critical factor, as opposed to Euler buckling for high strength graphite/epoxy.

With E-type fiberglass/epoxy or Aramid fiber/epoxy, it would take over 12 lb (5.44 kg) of material for an 83-1/2 inch-long tube to meet the compressive strength criterion.

With E-type fiberglass/epoxy, an 83-1/2 inch-long tube would have to have a diameter of six inches (152 mm) to marginally meet the Euler buckling criteria at the minimum weight required to meet the tensile and compressive strength criteria. For Aramid/epoxy, a tube 4-1/2 inches in diameter requires approximately 13 lb (5.9 kg) of material to meet the compressive strength criteria.

Accordingly, graphite fiber reinforced epoxy, using either high strength or high modulus fibers, constitutes a more weight-effective material than E-type fiberglass/epoxy or Aramid/epoxy. Graphite fiber reinforced epoxy is also more cost-effective than the aforementioned alternatives.

2.2.2 The Metal Fittings. The metallic parts are high strength 4140 alloy, weldable, military specification steel. Since more than 85% of the weight of the prototype tow bar is in the metallic fittings, a good design effort was necessary to minimize their weight contribution. Metal was removed wherever possible. However, a fitting factor of 1.2 was used in the design calculations to assure a safe design.

2.2.3 Adhesive Material Selection. A number of adhesives were considered for use in the tube-to-metal joint. Comparative tests were performed on these adhesive materials, which resulted in the choice being narrowed to two candidates. Because the adherends being joined are dissimilar materials, both adhesives were used, as will be discussed later.

2.3 Tow Bar Design

2.3.1 Composite Tube Design. The tube was sized for least weight, given the constraints of strength requirements, handability (i.e., ease with which the tube can be grasped by the average soldier), and damage resistance. An outside diameter of 4-1/4 inches was chosen as an acceptable compromise between the lesser weight of a larger diameter tube and

the need for the tube to be amenable to handling with a thumb-opposed grasp. Also, damage resistance is a function of thickness to diameter ratio, accordingly, the smaller diameter tube was felt to be less susceptible to damage.

The ply orientation is $+45^{\circ}/0^{\circ}/+45^{\circ}$. This orientation gives the tube the axial stiffness required for buckling resistance, yet yields a laminate with good overall strength and integrity. A preliminary choice of laminate orientation with some 45° plies at the mid-plane proved to have some processing difficulties and was discarded. The final laminate configuration showed no trace of the earlier problems, and was shown to be a good choice during tests. Wall thickness of the laminate was 0.21 inches (5.33 mm).

A Kevlar overwrap, consisting of four plies of woven fabric, was wrapped around the graphite/epoxy tubes. The sheath serves a dual purpose. Its primary purpose is to protect the graphite fiber laminate. Kevlar is highly resistant to abrasion and, in addition, can absorb considerable amounts of impact energy. Hence, the Kevlar overwrap offers protection to the underlying stress-bearing materials against scratches, nicks, etc., which would otherwise occur during service and which could jeopardize the tow bar's structural integrity. Sufficient Kevlar was used to allow for expected abuse of the tow bar while still being consistent with the 125 lb (56.7 kg) weight limitation.

The secondary function of the Kevlar overwrap is to serve as a mandrel during the fabrication process. First, the overwrap is formed on a male mandrel, cured, and trimmed to the proper size. Figure 6 illustrates a finished overwrap. The Kevlar overwrap is then used as an external mandrel, against whose interior the graphite/epoxy composite tube is formed.



FIGURE 6 — Finished Kevlar Sheath

2.3.2 Design of the Metal Parts. There are two types of metal parts used with the tow bar: the fittings which act as lugs, and the sleeves which are adhesively joined to the ends of the composite tubes.

The fittings include the lunette, the eyes, and the clevises. Typically, the worst problem with lug-type fittings is to make sure the transition area between the lug and the other end transfers the load adequately.

The lunette is the heaviest single part of the tow bar. Its function is to transfer the maximum expected load, in either tension or compression, from the towing vehicle to the two composite tubes, which in turn transfer the load, via metal fittings, to the towed vehicle. Figure 7 shows the lunette.

The large eye is the pintle attach point for the towing vehicle. The lunette divides the towing force, with 1/2 of the force directed onto the integral shaft and the other 1/2 of the force onto the deployable shaft which attaches and pivots at the set of lugs with the smaller eye.

The lunette, therefore, has both mechanical joints and a weld joint. Design calculations must be based on the strength properties of the steel alloy in the as-welded condition when dealing with metal at or near the weld. In other areas, the lunette is heat treated to strengths of 180,000 to 200,000 PSI (1.24×10^3 to 1.38×10^3 MPa) ultimate tensile strength. This heat treatment makes it possible to reduce section thickness and thus reduce weight, via improved strength.

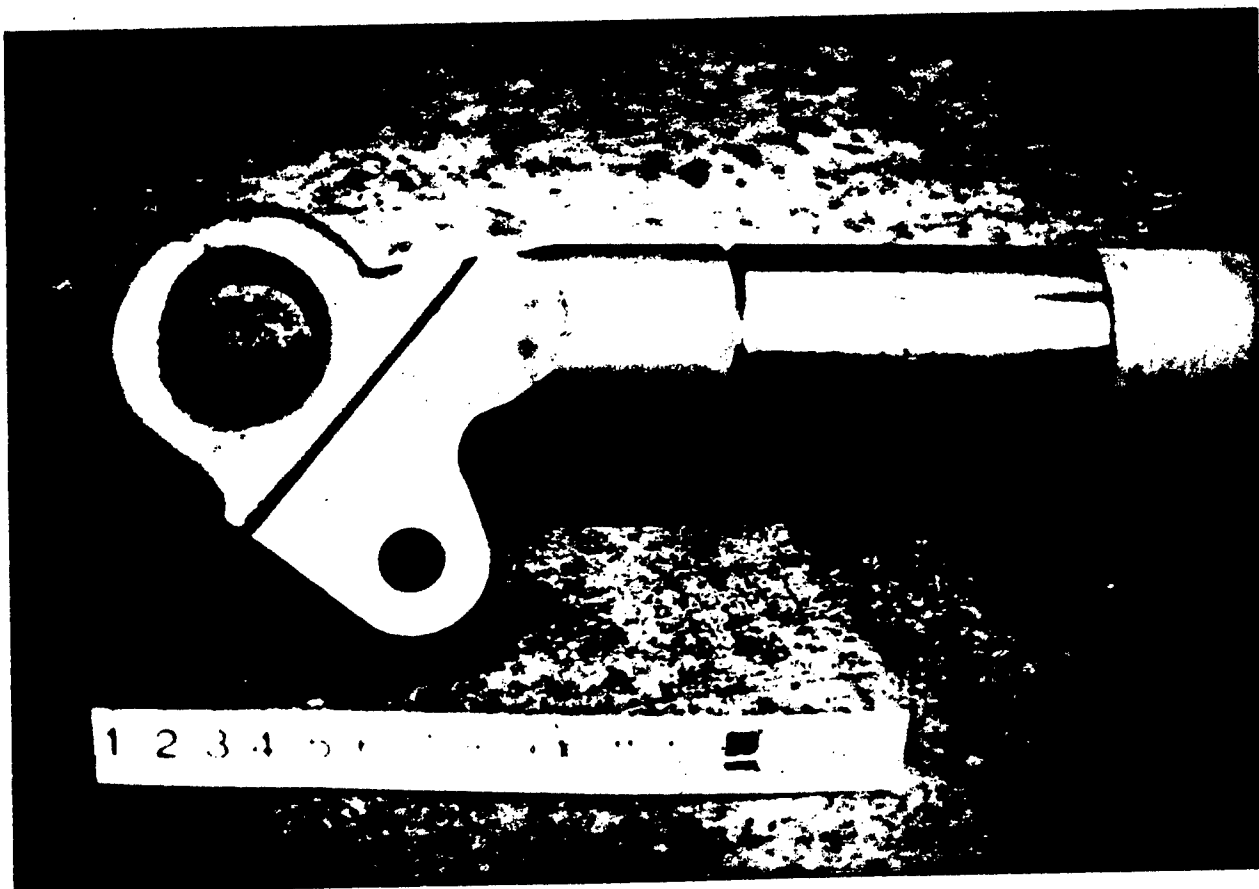

FIGURE 7 — Towing Lunette

Design of the eye shown in Figure 8 is more straightforward. At one end is a lug which serves as a mechanical joint. At the other end is a tube section which is welded to a metal sleeve, which in turn is adhesively bonded to one of the two composite tubes. A transition section is provided between the lug and the tube section. Like the lunette, the eye is heat treated at the lug end, to allow reduced section thickness and hence reduced weight.

The clevis (shown installed on the tow bar in Figure 9) is a double set of lugs at 90° to one another. The design problem with this part is to allow sufficient load transition area while reducing weight to a minimum. Because there are no welds, it is fully heat treated to 180,000 to 200,000 PSI tensile strength. The design is based on straightforward lug analysis, except that with one set of lugs there is a bending moment to consider, due to the geometry.

The sleeve (Figure 10) serves as a transition piece between the metallic components and the composite tubes. One end is welded to the lug fittings, which may be either an eye or the lunette. The opposite end is tapered, and is used to form an adhesive joint with an end of one of the composite tubes. The design of the sleeve-to-composite tube joint is discussed in the next paragraph.

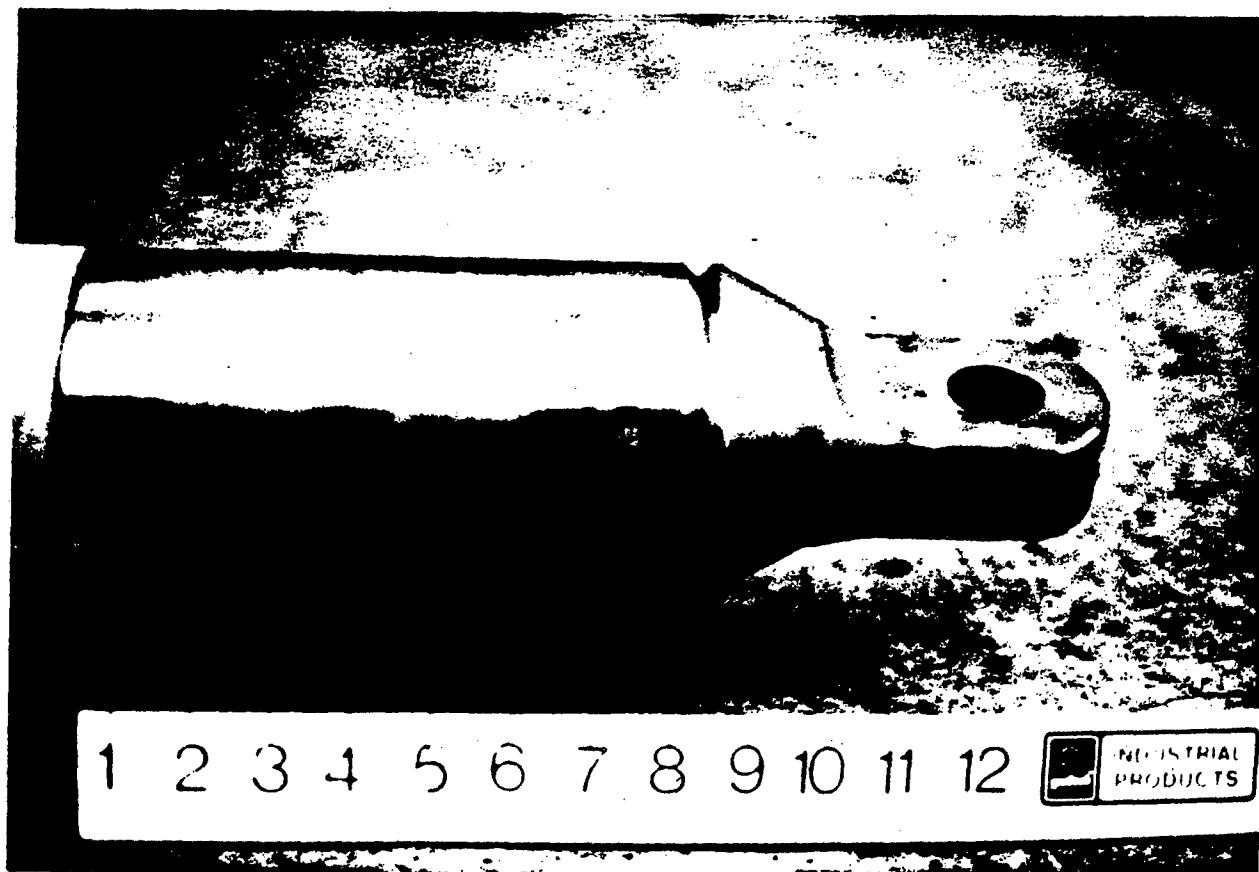

FIGURE 8 — Lunette Eye

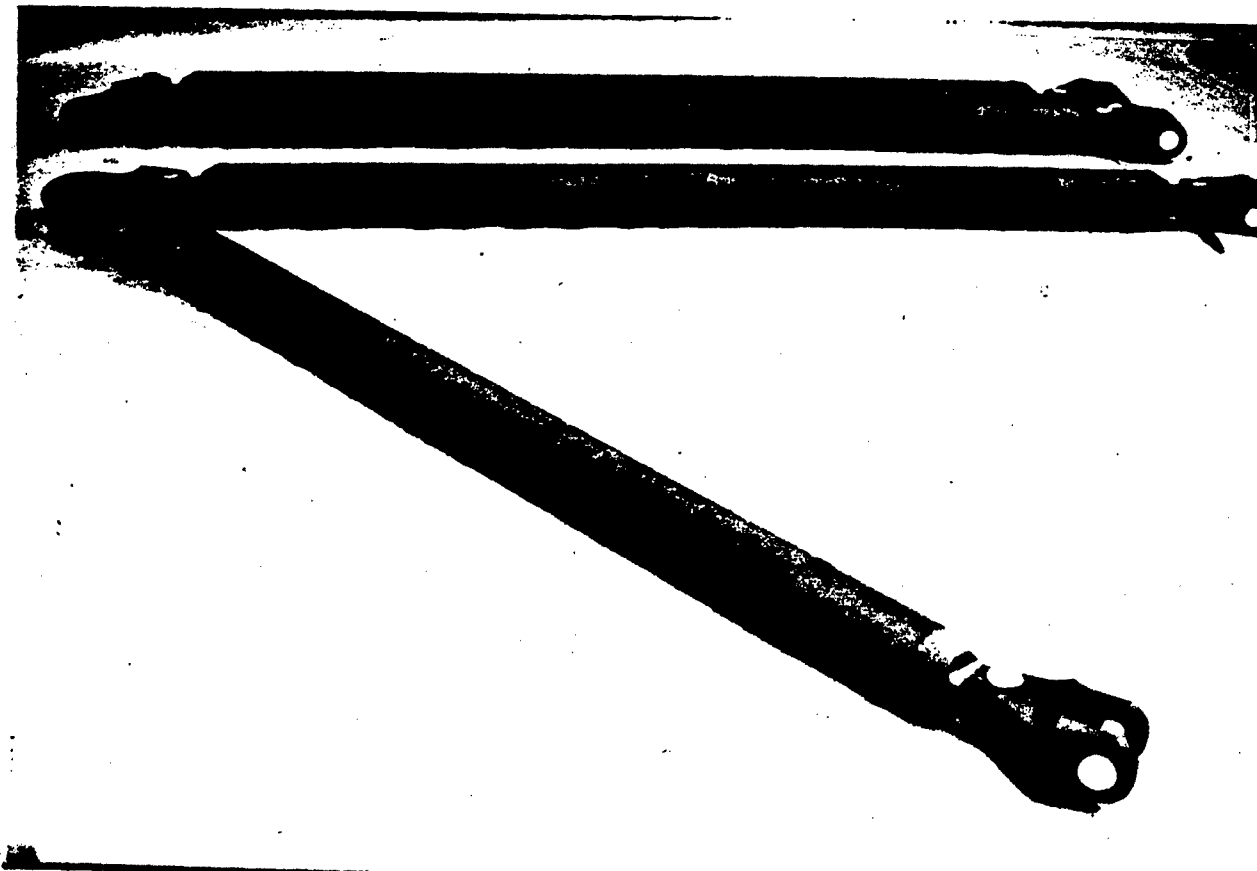

FIGURE 9 — Lunette Clevis/Lugs

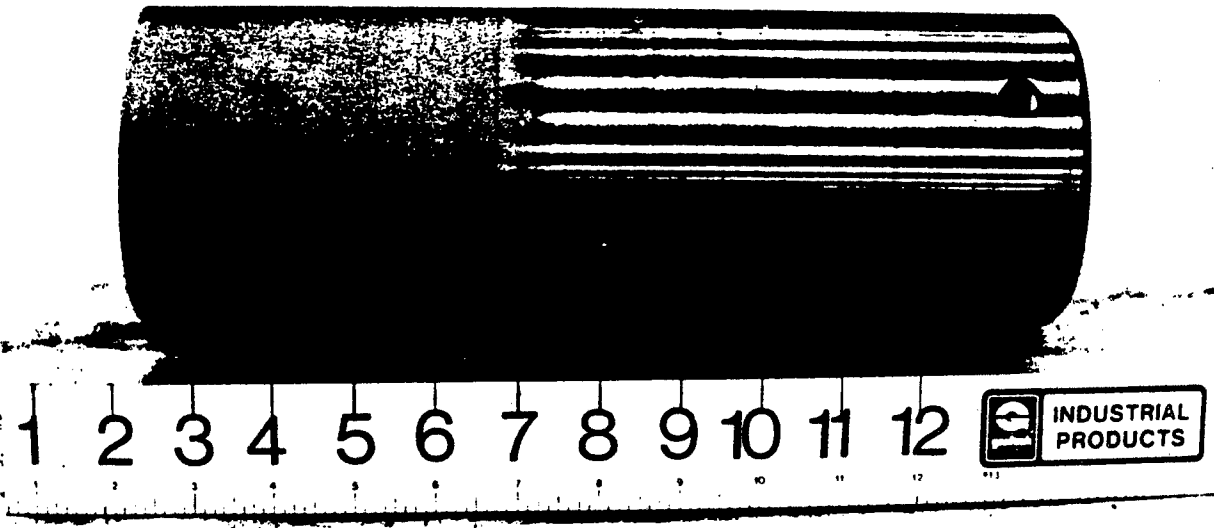

FIGURE 10 — Sleeve

2.3.3 Adhesive Joint Design. The primary problem of any joint is to smoothly transfer the load from one element to another. A composite-to-metal joint offers the additional problem of highly dissimilar properties which affect the joint loading rate. The joint design, then, must consider how to reduce the stress concentrations and peaking induced by this imbalance of properties. A mechanical joint using fasteners, while necessary in some conditions, is generally limited in composites due to the low bearing strengths of composite materials. In the design of the tow bar, an adhesive joint (shown in Figure 11) was considered to be the best solution.

In any adhesively bonded joint, there are shear stress peaks near the ends of the joint, due to shear lag. Figure 12 illustrates this for a double lap joint. A single scarf joint will reduce these end concentrations as Figure 13 illustrates.

As stated in the Advanced Composites Design Guide*, a unique characteristic of scarf joints is that bond shear strength can be increased indefinitely by increasing the length. Also, as the length of the joint is increased, the ratio of average shear stress to peak shear stress decreases asymptotically to a limiting value, which is equal to the lesser ratio of the extensional stiffness of the adherends. Thus, by maintaining a constant value for the modulus of each adherend times its thickness, the peak shear stress in the adhesive at the ends of the joint can be minimized.

*Volume II (Analysis), Third Edition, Third Revision, Paragraph 2.4.1.5.7.3

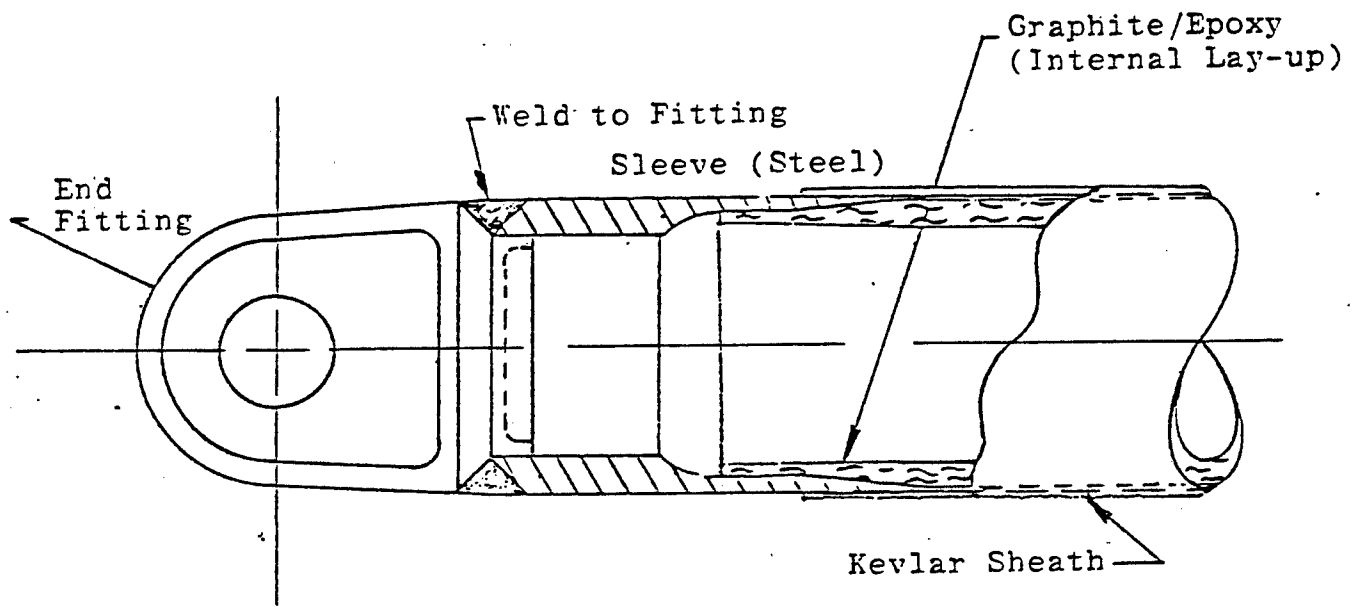

FIGURE 11

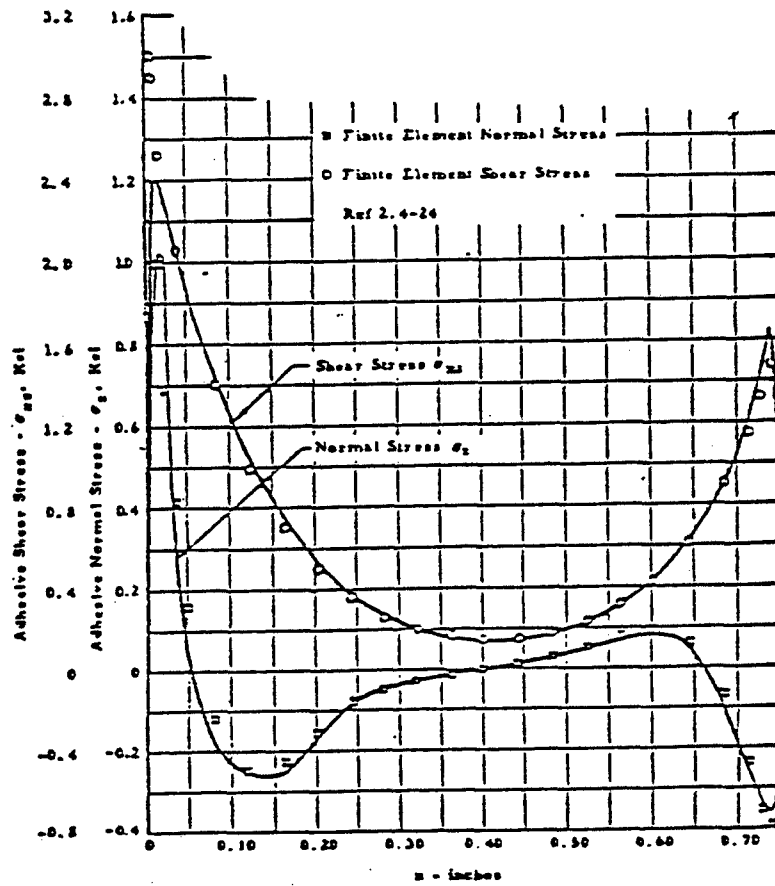
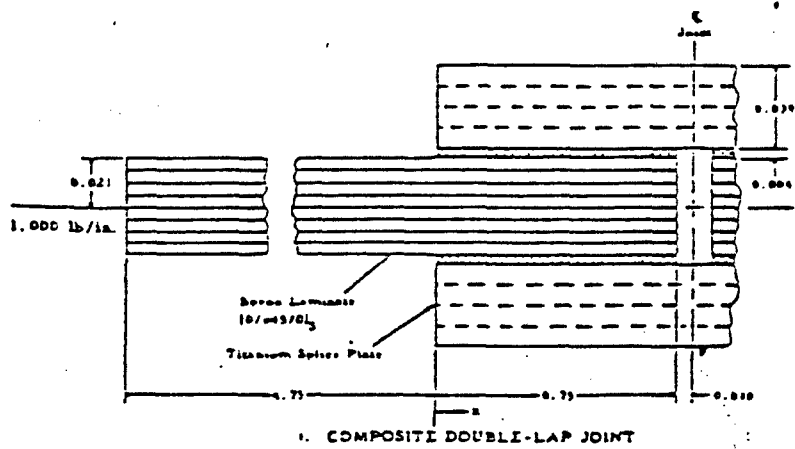

FIGURE 12 - Adhesive Shear and Normal Stresses in Composite Double-Lap Joint

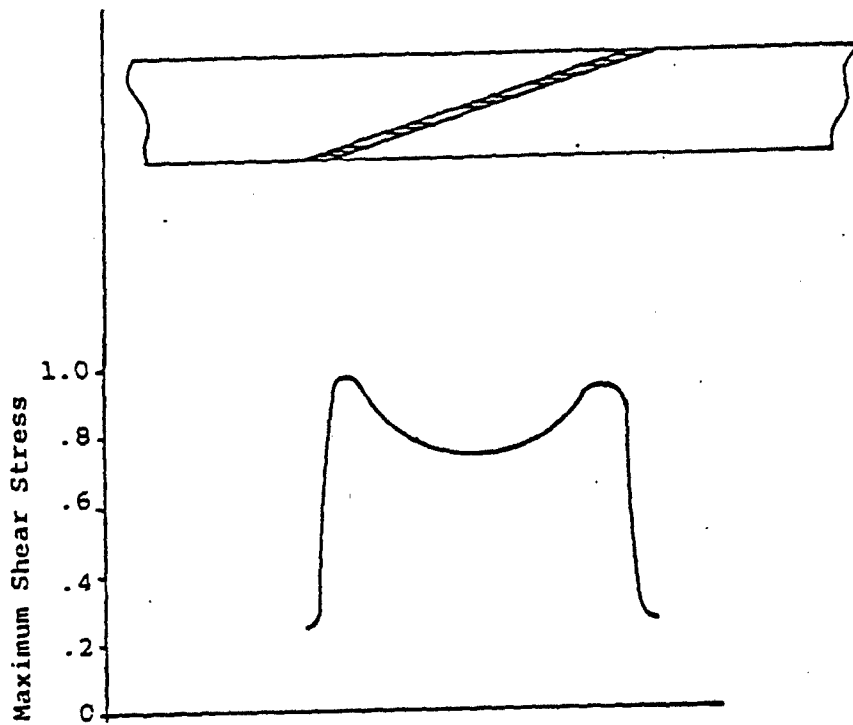

FIGURE 13 - Maximum Shear Stress in Scarf Adhesive Layer

This is accomplished by the joint configuration adopted for the tow bar. The modulus of the composite ply lay-up is approximately one-half that of steel, while the thickness of the steel sleeve is roughly one-half of the thickness required for the composite to meet the local buckling strength criteria. Thus the ratio of the extensional stiffness of the steel and composite sections at the joint is approximately unity. This results in a peak shear stress in the adhesive which, in theory, is not much more than the average shear stress.

A finite element model and analysis were made of the steel-to-composite joint to attempt to verify the design. This analysis is shown in the following section. Variations on the design were tried in an attempt to lower the peak stresses which occurred at the ends of the joint. These models demonstrated several points of interest in joint design:

a. A tapered joint does reduce the peak stresses at the ends of the joint, but changes in the slope or even the location of the taper do not affect the end peak stresses appreciably. The stresses in the interior are affected, but these stresses are generally less than 1/2 of the beginning peak stresses.

b. Holes in the adherends or holes in the adhesive (which might represent unbonded areas) have no real affect on the joint as long as they do not occur at the end of the joint. This shows that as long as care is taken at the joint ends, the joint is rather forgiving of manufacturing errors.

c. Use of adhesives with different stiffnesses has an approximately 10% effect on the peak stress. By using an adhesive with lower stiffness

at the ends of the joint, and an adhesive with higher stiffness in the central portion of the bonded area, the shear stresses at the ends can be reduced.

The bond shear strength was conservatively assumed to be 1000 PSI (6.895 MPa) when carrying out the design calculations. According to vendor-supplied data, a lap joint specimen was tested at an average bond shear stress of 3500 PSI (24.13 MPa).

Proximity of the adhesive joint to a weld could result in degradation of the adhesive, but precautions during welding were taken to minimize heat build-up and promote heat dissipation away from the joint. During the test made by TACOM on the "first article" tube, a weld was made in the same area where the design weld would be placed. There was no apparent detriment to the adhesive joint's ability to bear the required load.

3.0 ANALYSIS

Analysis must proceed with a design in order to have a base on which to build. Part of this section discusses the early analysis done in order to design the composite-to-metal sleeve joint correctly. This finite element analysis is discussed first. Then, an analysis of the final design, component-by-component, is presented as proof of the design.

3.1 Finite Element Analysis of the Adhesive Joint

A finite element model was made to simulate the adhesive tapered lap shear joint of the composite tube to the metallic sleeve. The model is shown in Figure 14.

The purpose of the model was to analytically check the stresses and the distribution of stresses which occur in the bond line between the metal and composite adherends.

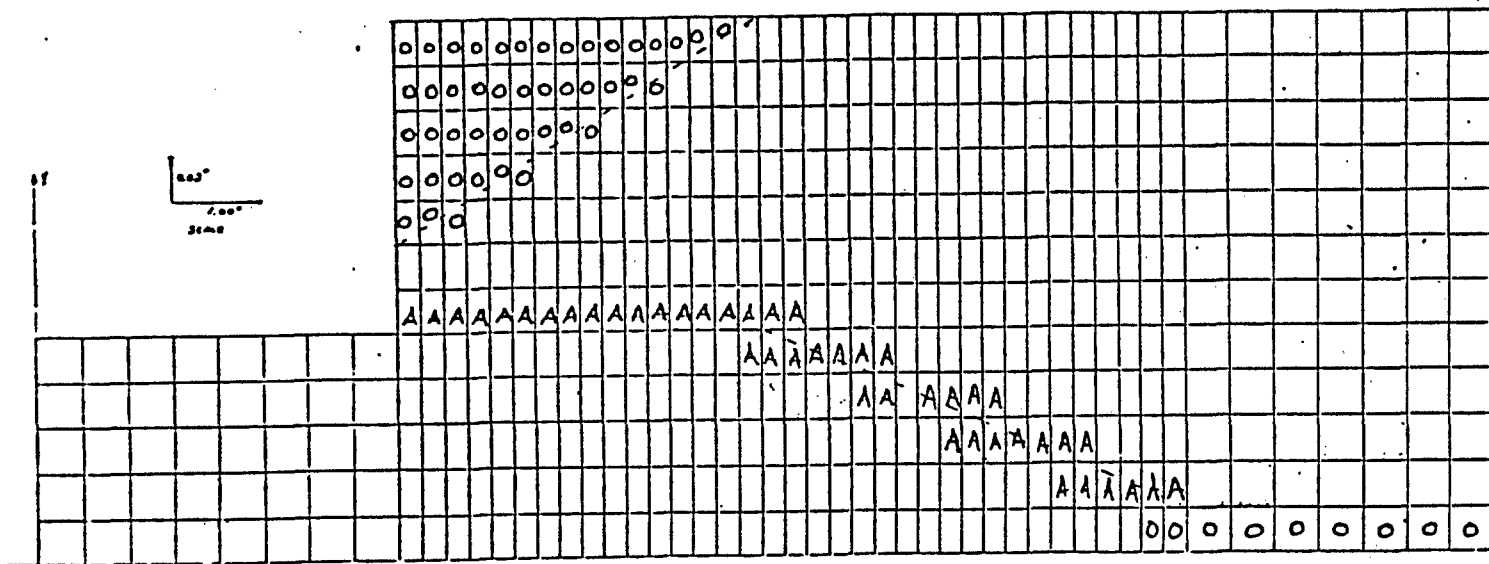

FIGURE 14 - TACOM Finite Element (F.E.) Model of Tow Bar Adhesive Joint

The double-tapered lap joint for the lightweight composite tow bar was modeled using the CQUAD2 element of NASTRAN level 17.5. This model contained 556 elements and was of a two-dimensional configuration. To ease input data generation, the model was made in a rectangle configuration and elements located where no material existed were given material properties approaching zero. The zero property elements are marked with '0' in Figure 14 and the elements representing the adhesive are marked with an 'A'. The model, in all other aspects, matched the geometry of the joint exactly. Various changes in the geometry, such as taper ratio and adhesive line placement, as well as different types and combinations of adhesives, were explored. A total of seven separate computer model runs were made.

NASTRAN's CQUAD2 element is a quadrilateral plate element with both in-plane and bending stiffnesses that assume a solid homogeneous cross-section. The material properties of a given element can be modeled as linear, temperature-independent, and isotropic; or linear, temperature-dependent, and anisotropic. In our model, we used both types of material data input to model the steel, adhesive, and composite appropriately.

Run No. 1 (performed on the model shown in Figure 15) was carried out to establish a data base for comparison with the results of subsequent runs. In this way, the relative merits of the various configurations could be judged. The initial model has adhesive properties identical to those of the resin used in the laminate. The results of that run are plotted in Figure 16.

The abscissa is the distance along the joint length from all metal at the origin to all composite at the extreme right.

Comparing the model to the graph, it can be seen that there are three peak stress locations: at the tip of the composite material, at the beginning of the taper in the metal and at the tip of the metal. These peak stresses are associated with shear lag in the joint.

A lap joint without a taper is characterized by a shear stress distribution with peaks only at the corners. The area in the middle of the joint is ineffective and as can be seen from Figure 17, the shear stress in the middle is many times smaller than the peak tip stresses.

As a comparison of Figures 16 and 17 indicates, the tow bar joint design geometry increases the effectivity of the center portion of the joint and thereby decreases the tip peaking.

Figures 18 and 19 show the same geometry as Figures 15 and 16, but now the adhesive is modeled as having the properties of Narmco Metal Bond 1113 adhesive. The curves, as might be expected, are very similar. The maximum peak stress was reduced, however, due to the reduced stiffness of the adhesive from 3,500 PSI to 3,200 PSI (24.13 to 22.06 MPa), or approximately 9%.

From the results of Figure 17, compared to Figure 19, it might be predicted that a "stiff" adhesive used in the middle of the joint and a "soft" adhesive used at the tips might cause a transfer of load to the middle section of the joint, away from the regions of peak stress. The model affirmed this. Using a softer adhesive for the first and last inch of the joint reduced the stresses at the tip. A small peak formed at the glue transition line. Figures 20 and 21 illustrate the case of a joint using both "stiff" and "soft" adhesives.

Analysis of peak stresses reveals a reduction from 3,200 PSI for the "all stiff" adhesive to 3,000 PSI (22.06 to 20.68 MPa), a reduction of about six percent.

Model No. 4 looked at the problem of a 'hole' in the glue. A one-inch length of the glue line was given zero properties to simulate a hole. Figures 22 and 23 show this hole and the resulting shear stresses. Almost no effects are felt at the tips and 'mini-peaks' occur at the hole edge. These results indicate that the joint is very forgiving of processing errors or omissions in the center of the joint. Tips of the joint, however, must be carefully made.

Model No. 5 investigated the possibility of utilizing a double taper. The basic concept was to induce shear stress peaks in the central region, and hence reduce the magnitude of the peaks at the ends of the joint. By using two slope transitions, it was hoped that the peak normally occurring in the middle of the joint (at the junction between the flat and sloped areas) could be made to occur twice. Figure 24 illustrates the model. The results, shown in Figure 25, reveal that the two peaks do occur as per the original concept, but the peak stresses are not reduced.

Model No. 6, shown in Figure 26, investigates the effects of changing the slope of the bond line. It was theorized that by increasing the length of the slope, the shear stresses at the ends of the joint would be reduced. The results of the computer run, shown in Figure 27, confirm that a reduction in shear stress at the joint ends does occur, but only to a limited extent - from 3,000 PSI to 2,800 PSI (20.68 to 19.31 MPa), or 7%.

Another configuration subjected to computer evaluation involves reducing the extensional stiffness of the metal sleeve by drilling three rows of holes. In the model shown in Figure 28, properties are lowered to simulate metal removal. The results, shown in Figure 29, reveal that peak stresses are increased, not decreased, by 200 PSI (1.379 MPa) relative to the base configuration.

Model No. 6 was the adhesive joint configuration finally adopted. As noted above, a peak shear stress of 2800 PSI was determined by computer calculations for this arrangement.

In order to judge if the results from these models are valid, computer modeling of the standard lap-type shear test specimen was carried out, assuming both AF 13 (manufactured by 3M) and Metalbond 1113 (Narmco) adhesives. The results of these runs were compared with laboratory test data. In general, test results are given in terms of "averaged" stresses (i.e., load divided by area). It is known that peak stress far exceeds this number and the middle stresses are far below it. Laboratory tests have shown that a smeared or average shear stress reported by testing or by a vendor of 3,000 PSI; e.g., either AF 13 or Narmco 1113 adhesive, corresponds to about 3,500 PSI (See Section 5). The model of the one-inch square bond area test specimen is shown in Figure 30 and the results in Figure 31 are for the Narmco Metalbond 1113. The results for AF 13 are shown in Figure 32.

In both cases, the peak stresses are roughly 3-1/2 times the average stress. This says that a test specimen which fails at an averaged stress of 3,000 PSI is experiencing a peak stress of 10,000 PSI (869.95 MPa) or more.

Since the peak stresses of the models are only 2,800 PSI, the joint may be viewed as very conservative.

It may be noted, however, that the average stress for the joint is about 1,000 PSI. This says the peak stress is 2.8 times the average. Thus, with all that was accomplished, using both geometry and material properties, peak stresses were reduced 25% from a step lap joint.

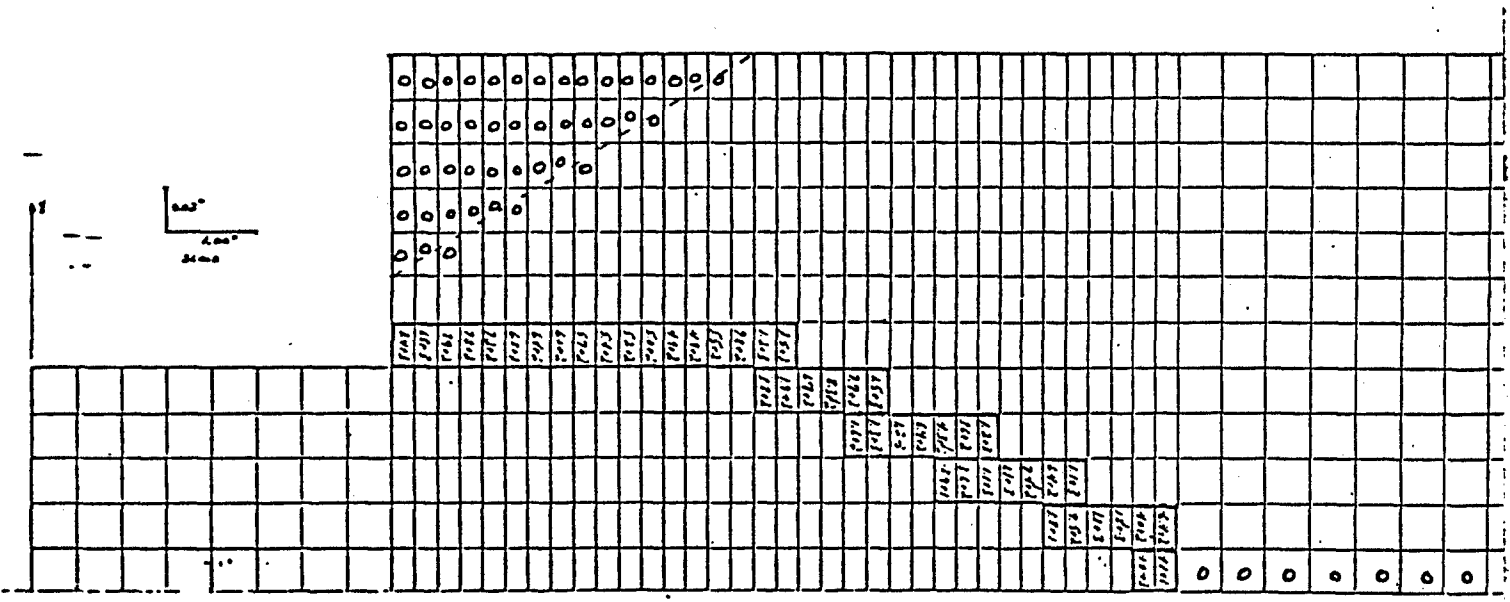

FIGURE 15 - Run #1, TACOM F.E. Model of Reference Tow Bar Adhesive Joint

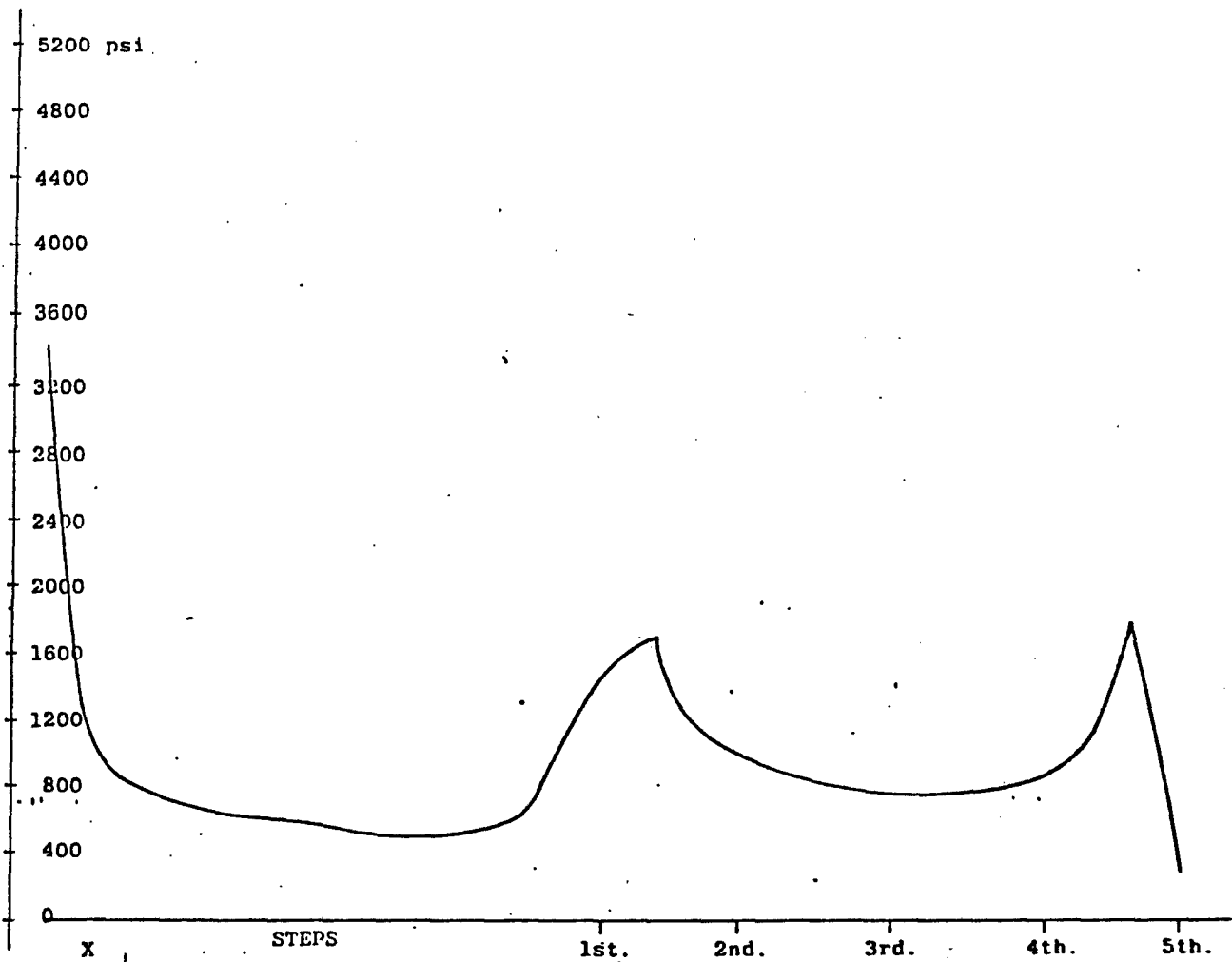

FIGURE 16 - TACOM F.E. #1 Glue Shear X-Y
(Resin Glue)

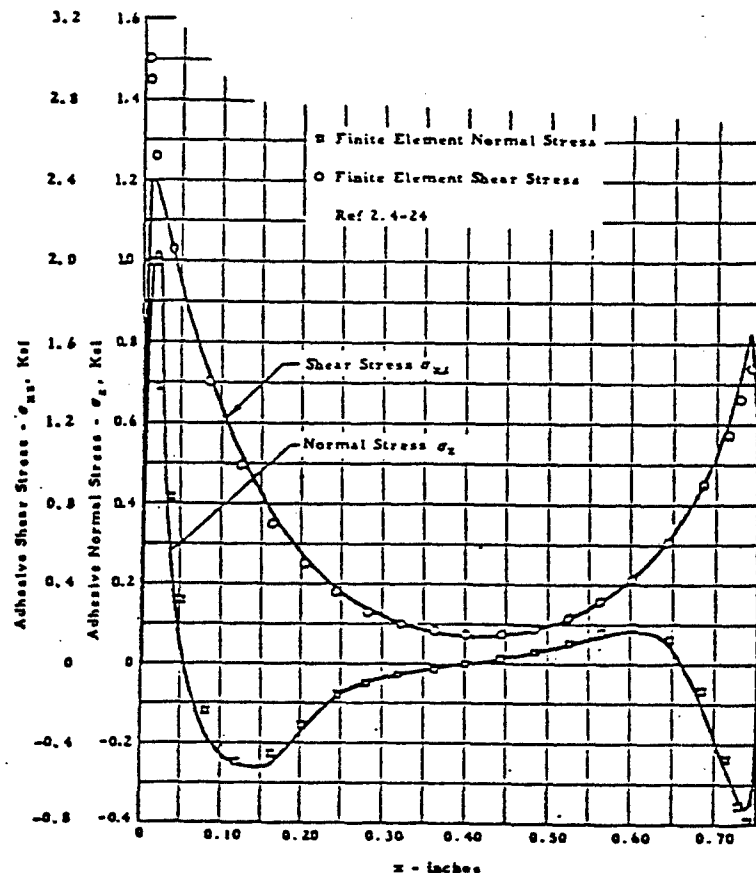
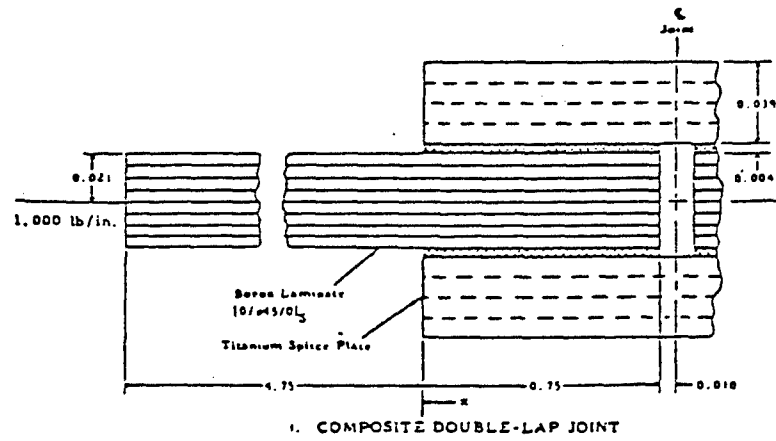

FIGURE 17 - Adhesive Shear and Normal Stresses In Composite Double-Lap Joint

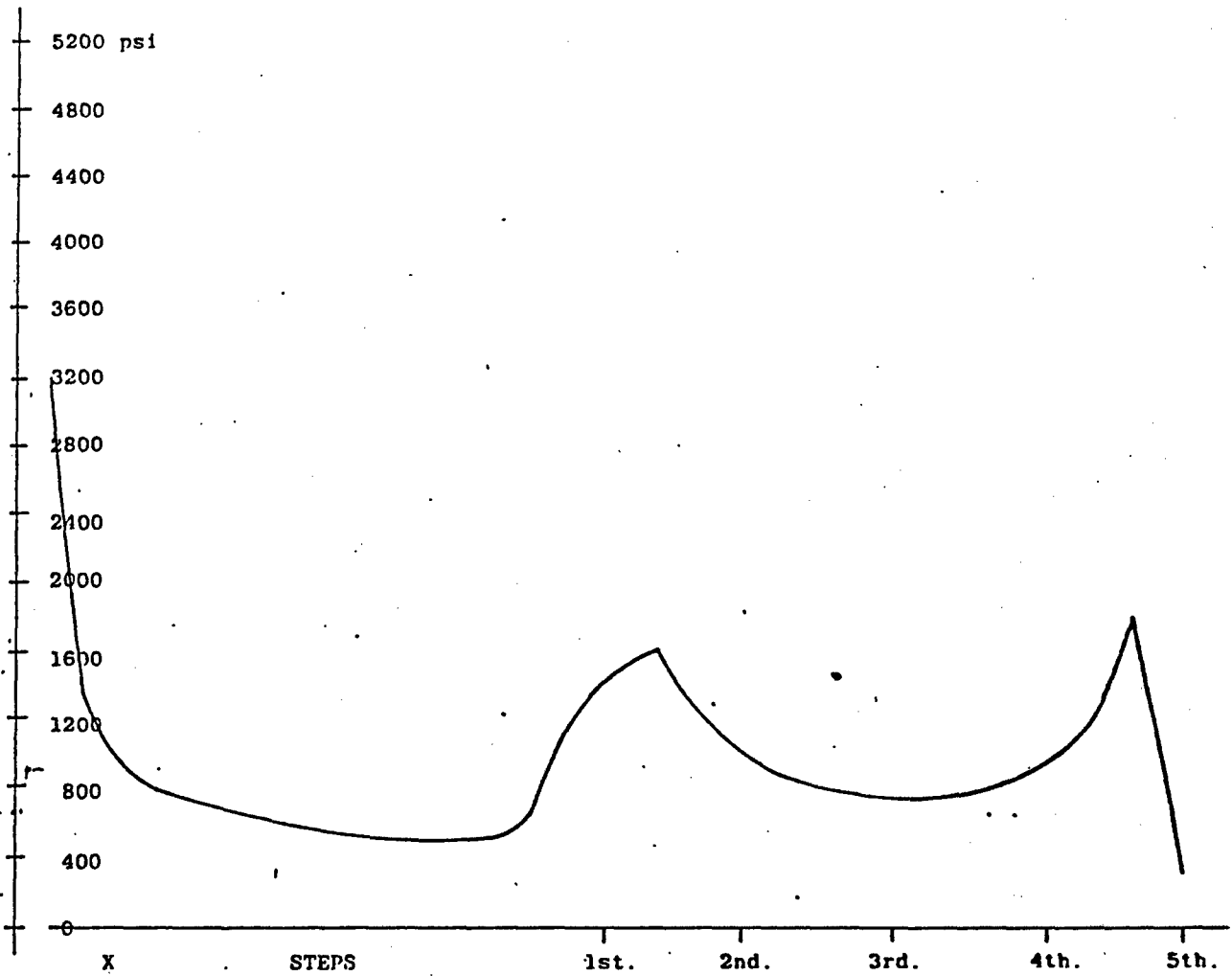

FIGURE 19 - TACOM F.E. #2 Glue Shear X-Y
(1133 Glue)

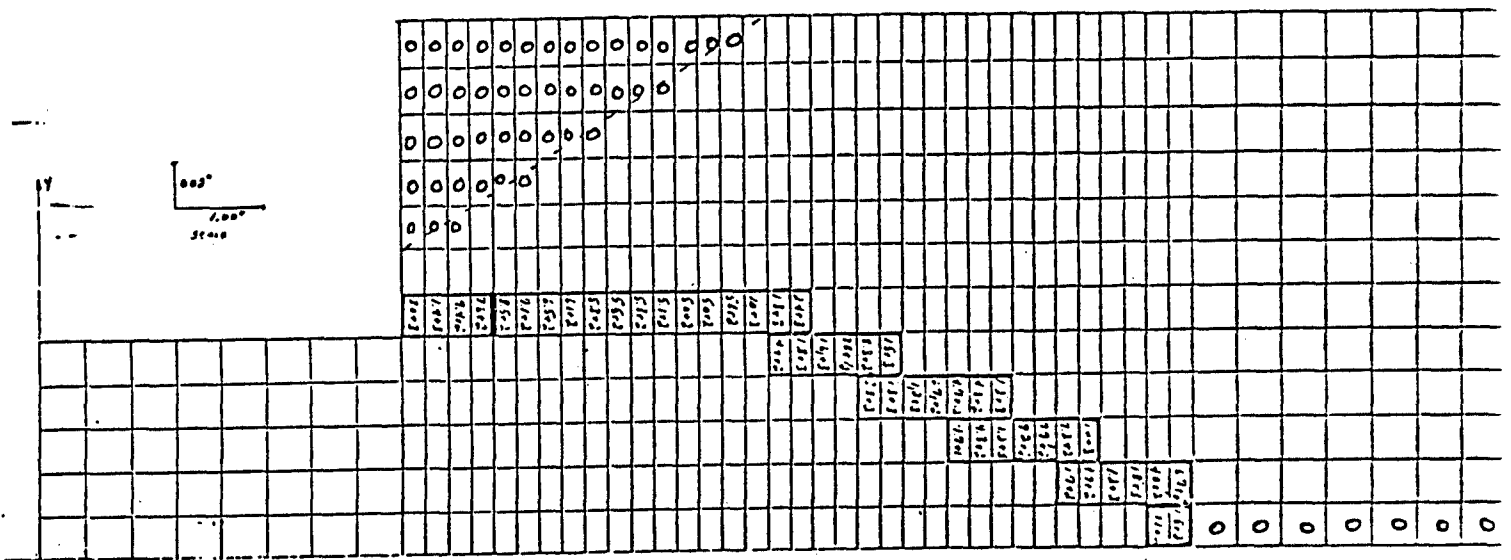

FIGURE 20 - Run #3, TACOM F.E. Model of Tow Bar Adhesive Joint Using "stiff" and "soft" Adhesives

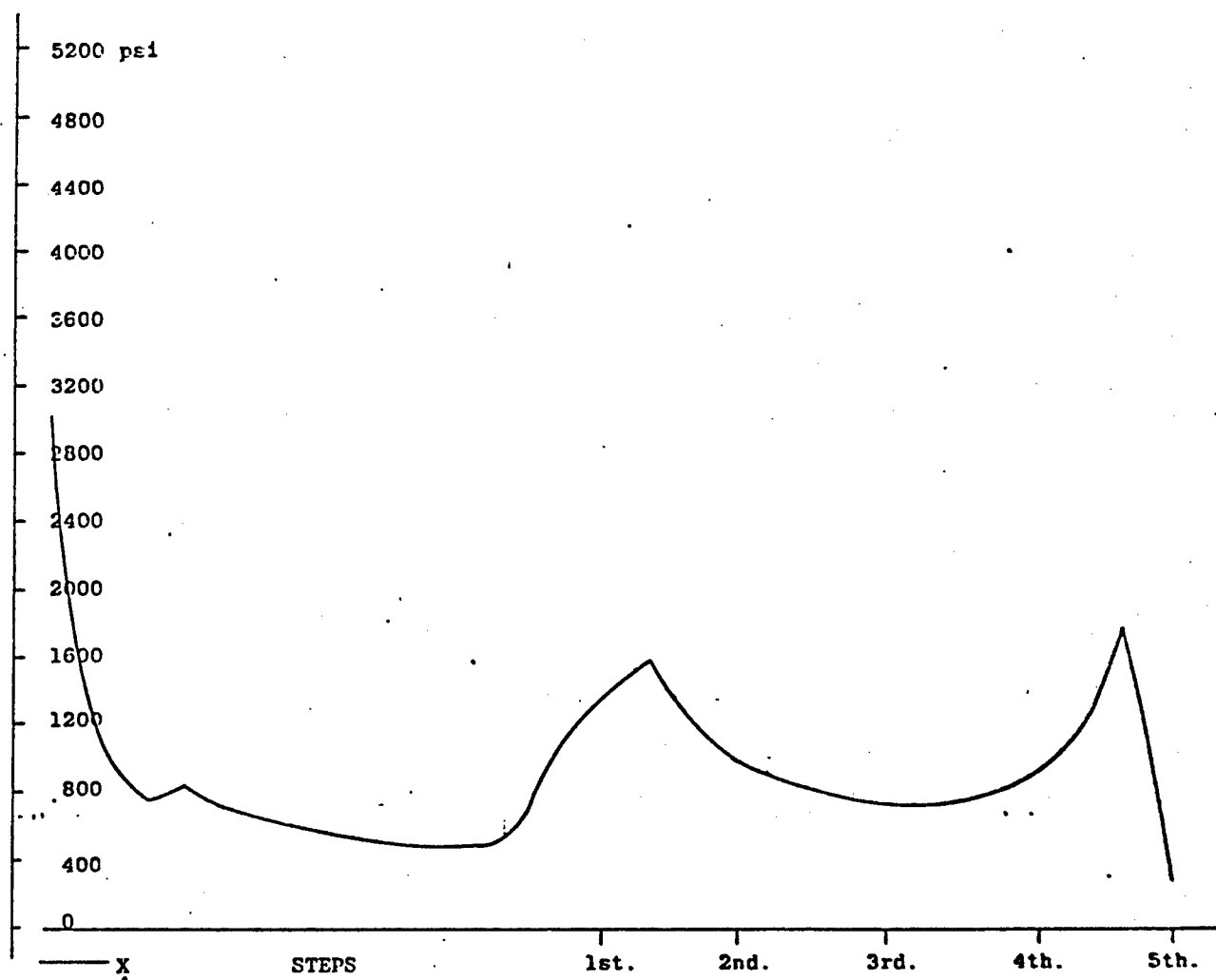

FIGURE 21 - TACOM F.E. #3 Glue Shear X-Y
(AF-13 and 1113 Glue)

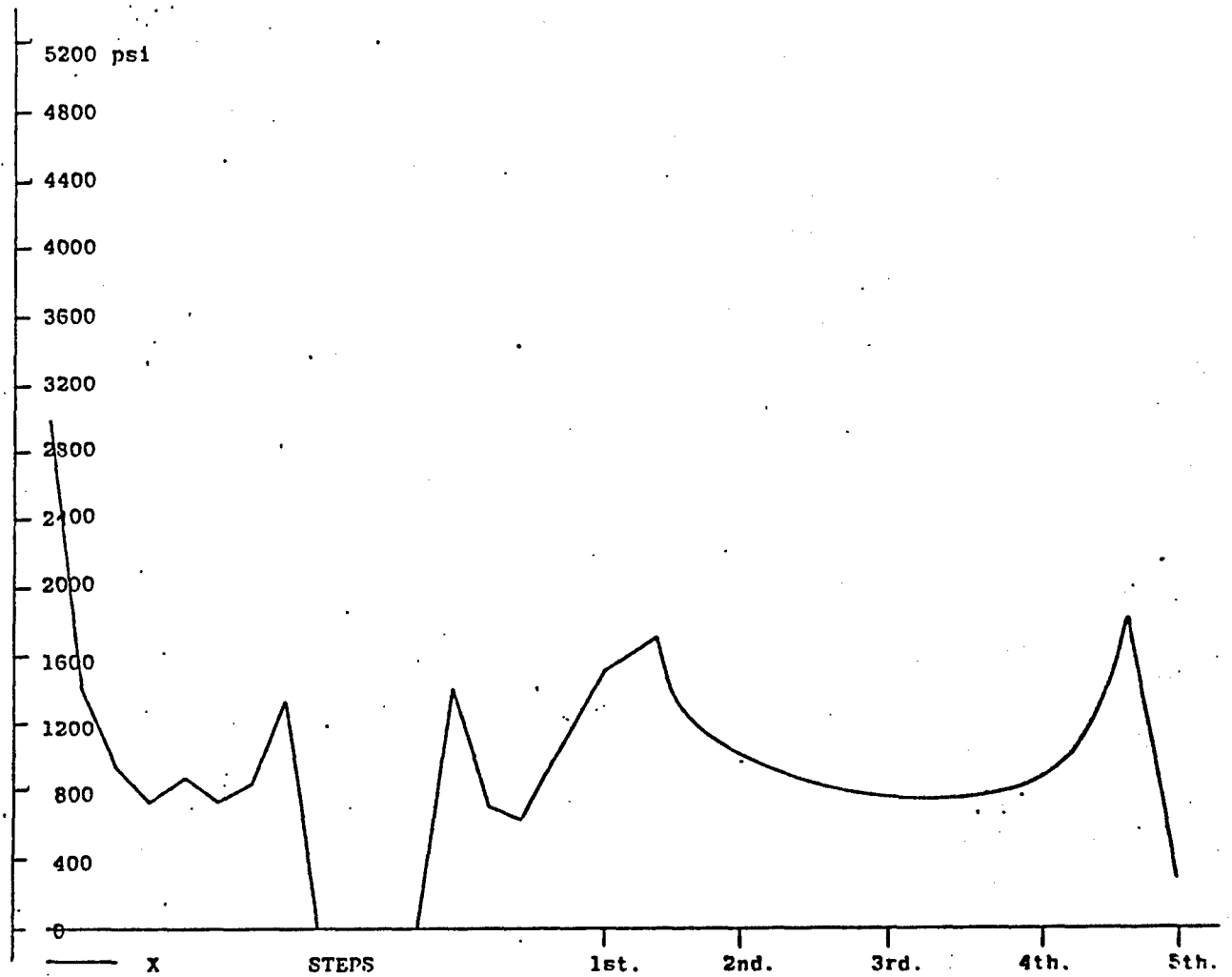

FIGURE 23 - TACOM F.E. #4 Glue Shear X-Y
(AF 13 1113 Glue w/Hole)

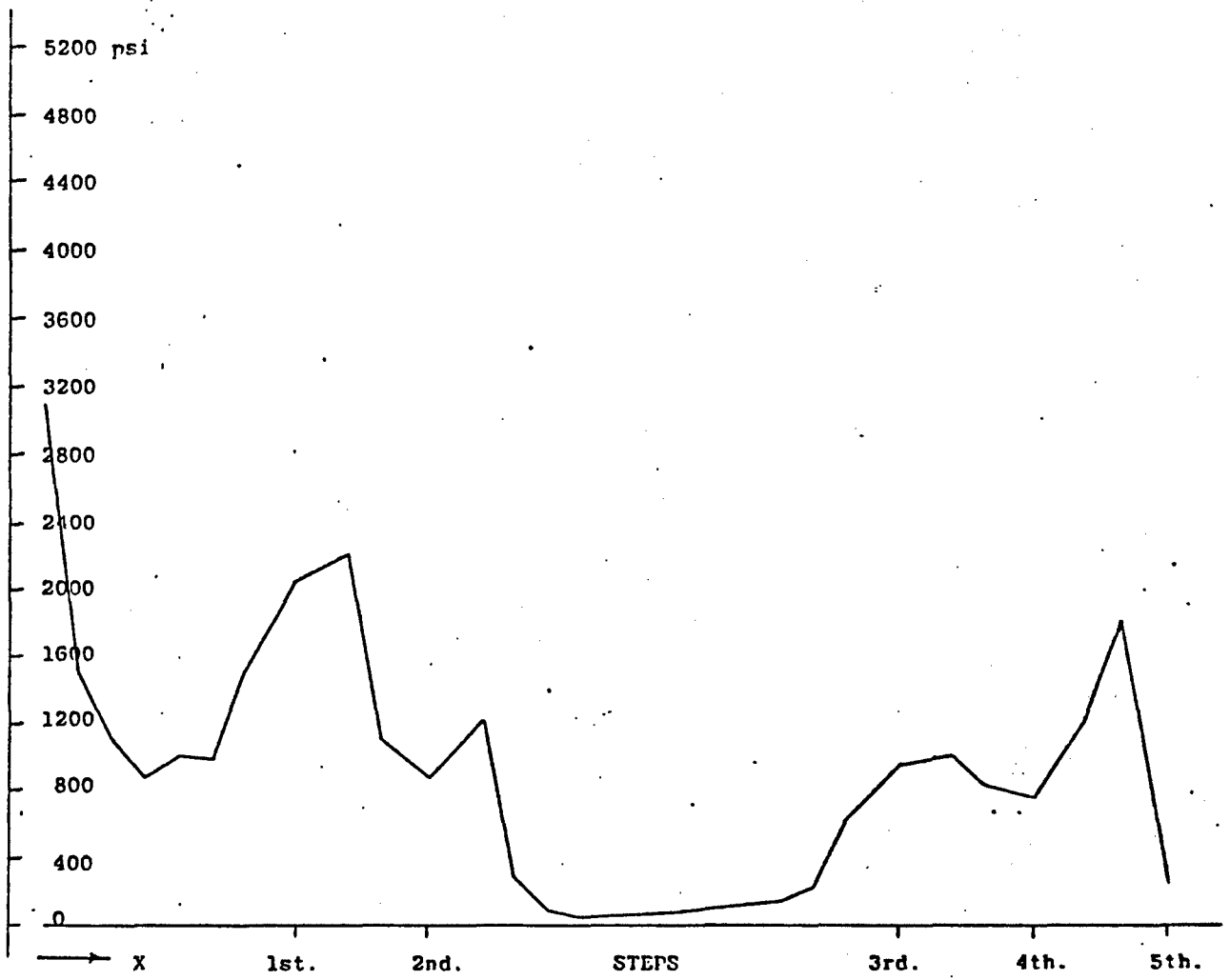

FIGURE 25 - TACOM F.E. #5 Glue Shear X-Y
 (AF 13, 1113 Glue + Diff. Glue Line)

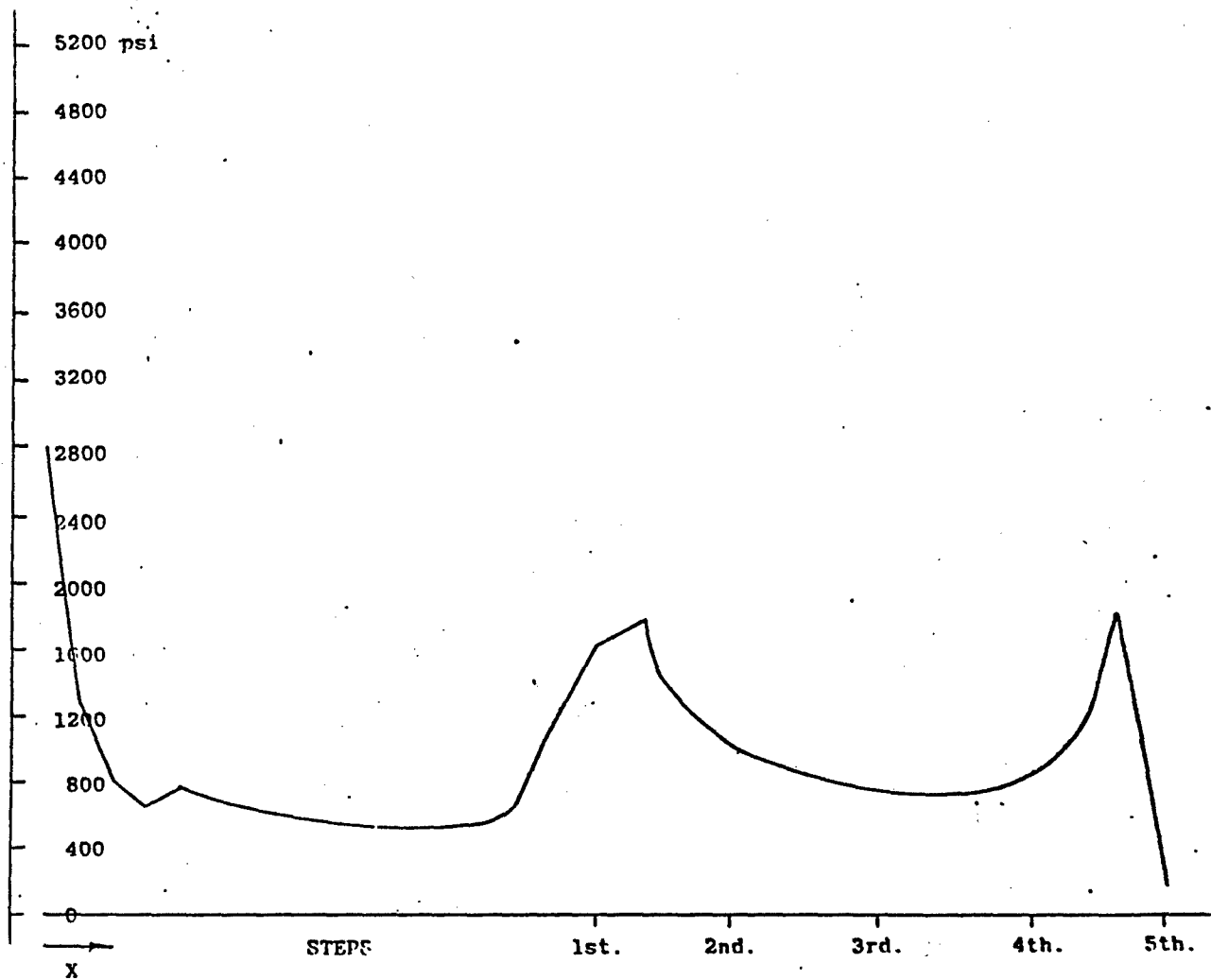

FIGURE 27 - TACOM F.E. #6 Glue Shear X-Y
(Run #3 & Larger Slope on Comp.)

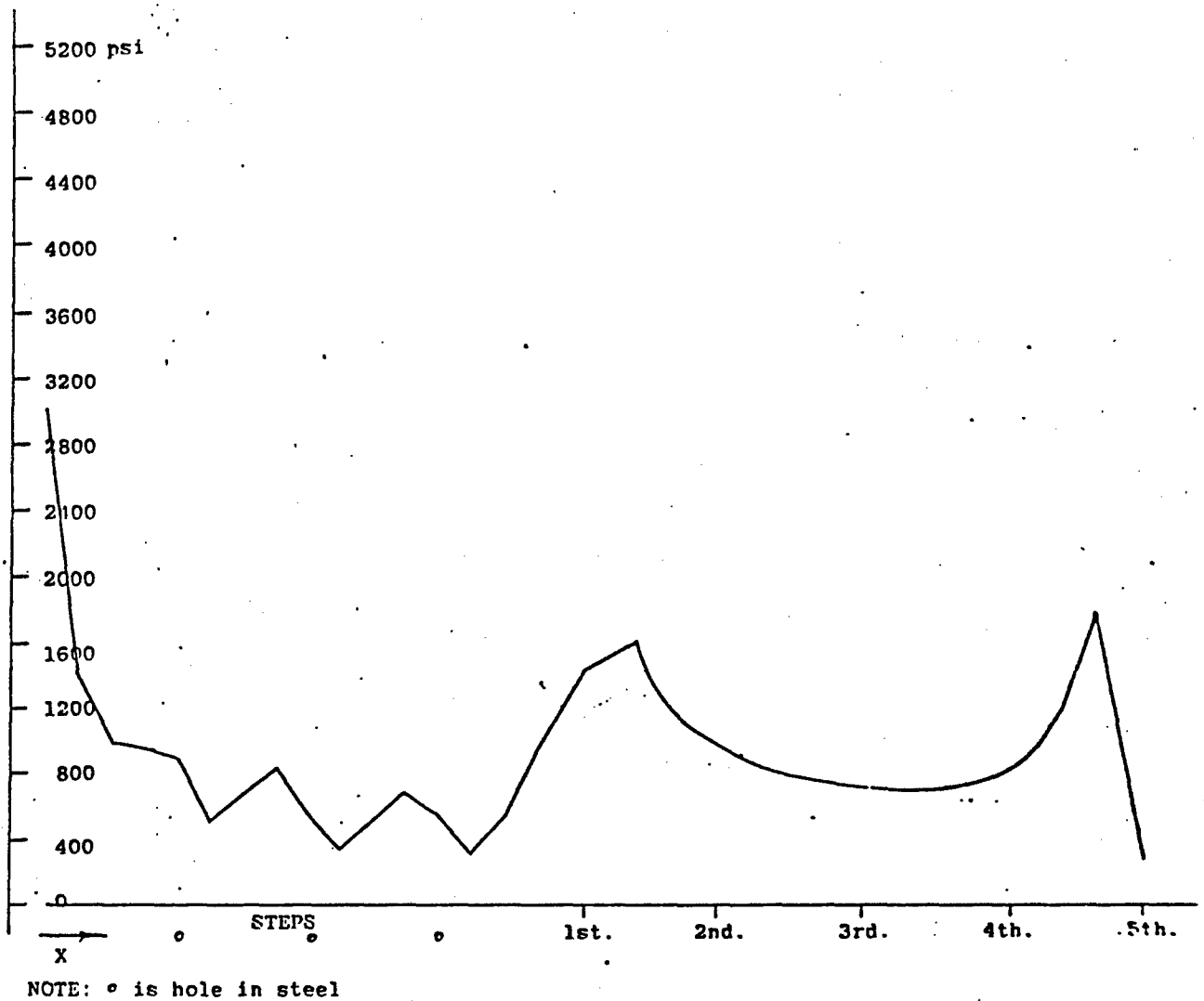

FIGURE 29 - TACOM F.E. #7 Glue Shear X-Y
(Run #3 & 3/4 Steel in Three Rows)

Lap Joint Test
 600 Element
 -Glue Section- (AF13)
 Shear Stress X-Y

E	9.8e3	9.8e3	9.8e3	9.8e3
F	9.4e3	9.0e3	9.0e3	8.4e3
G	8.0e3	8.0e3	8.0e3	8.0e3
H	7.2e3	7.2e3	7.2e3	7.2e3
I	6.4e3	6.4e3	6.4e3	6.4e3
J	5.7e3	5.7e3	5.7e3	5.7e3
K	5.1e3	5.1e3	5.1e3	5.1e3
L	4.6e3	4.6e3	4.6e3	4.6e3
M	4.1e3	4.1e3	4.1e3	4.1e3
N	3.7e3	3.7e3	3.7e3	3.7e3
O	3.3e3	3.3e3	3.3e3	3.3e3
P	3.0e3	3.0e3	3.0e3	3.0e3
Q	2.7e3	2.7e3	2.7e3	2.7e3
R	2.4e3	2.4e3	2.4e3	2.4e3
S	2.2e3	2.2e3	2.2e3	2.2e3
T	2.0e3	2.0e3	2.0e3	2.0e3
U	1.9e3	1.9e3	1.9e3	1.9e3
V	1.6e3	1.6e3	1.6e3	1.6e3
W	1.7e3	1.7e3	1.7e3	1.7e3
X	1.6e3	1.6e3	1.6e3	1.6e3
Y	1.5e3	1.5e3	1.5e3	1.5e3
Z	1.4e3	1.4e3	1.4e3	1.4e3
AA	1.4e3	1.4e3	1.4e3	1.4e3
AB	1.3e3	1.3e3	1.3e3	1.3e3
AC	1.4e3	1.3e3	1.3e3	1.3e3
AD	1.1e3	1.1e3	1.1e3	1.1e3
AE	1.3e3	1.2e3	1.2e3	1.2e3
AF	1.3e3	1.3e3	1.3e3	1.3e3
AG	1.3e3	1.3e3	1.3e3	1.3e3
AH	1.4e3	1.4e3	1.4e3	1.4e3
AI	1.4e3	1.4e3	1.4e3	1.4e3
AJ	1.5e3	1.5e3	1.5e3	1.5e3
AK	1.6e3	1.6e3	1.6e3	1.6e3
AL	1.8e3	1.8e3	1.8e3	1.8e3
AM	1.9e3	1.9e3	1.9e3	1.9e3
AN	2.1e3	2.1e3	2.1e3	2.1e3
AO	2.3e3	2.3e3	2.3e3	2.3e3
AP	2.6e3	2.5e3	2.5e3	2.5e3
AQ	2.9e3	2.8e3	2.8e3	2.7e3
AR	2.7e3	2.8e3	2.9e3	3.0e3

FIGURE 30

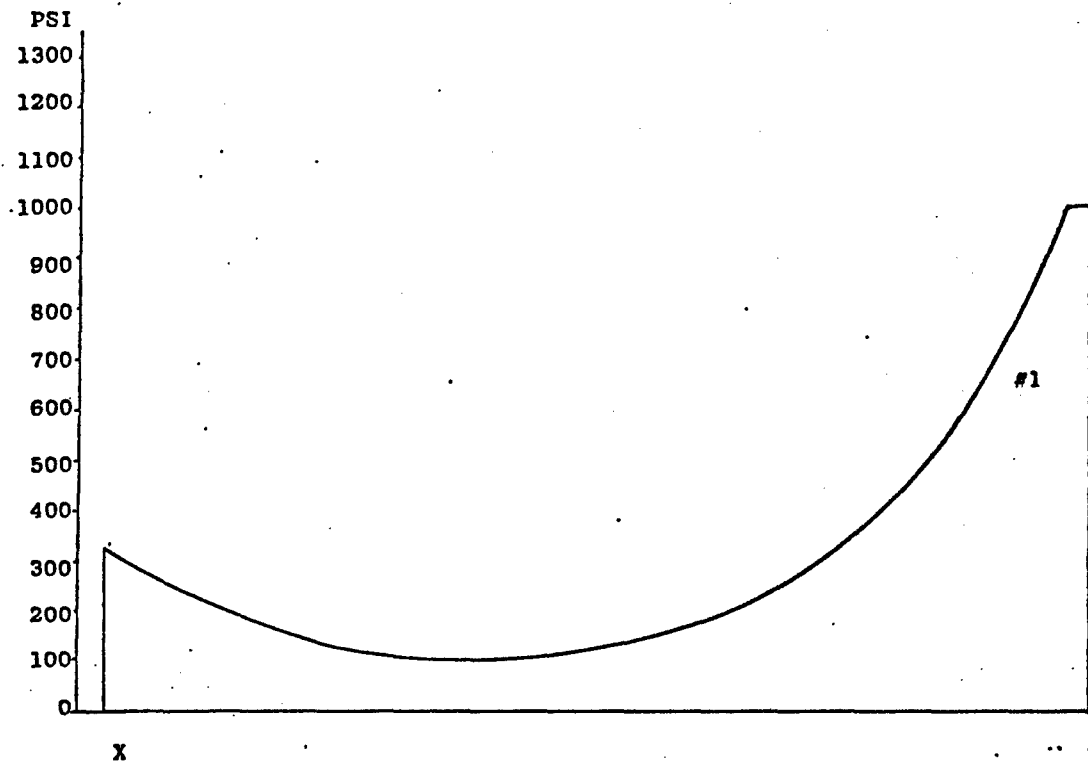

FIGURE 31 - Area Under Curve #1 =
2990.125 psi/in²

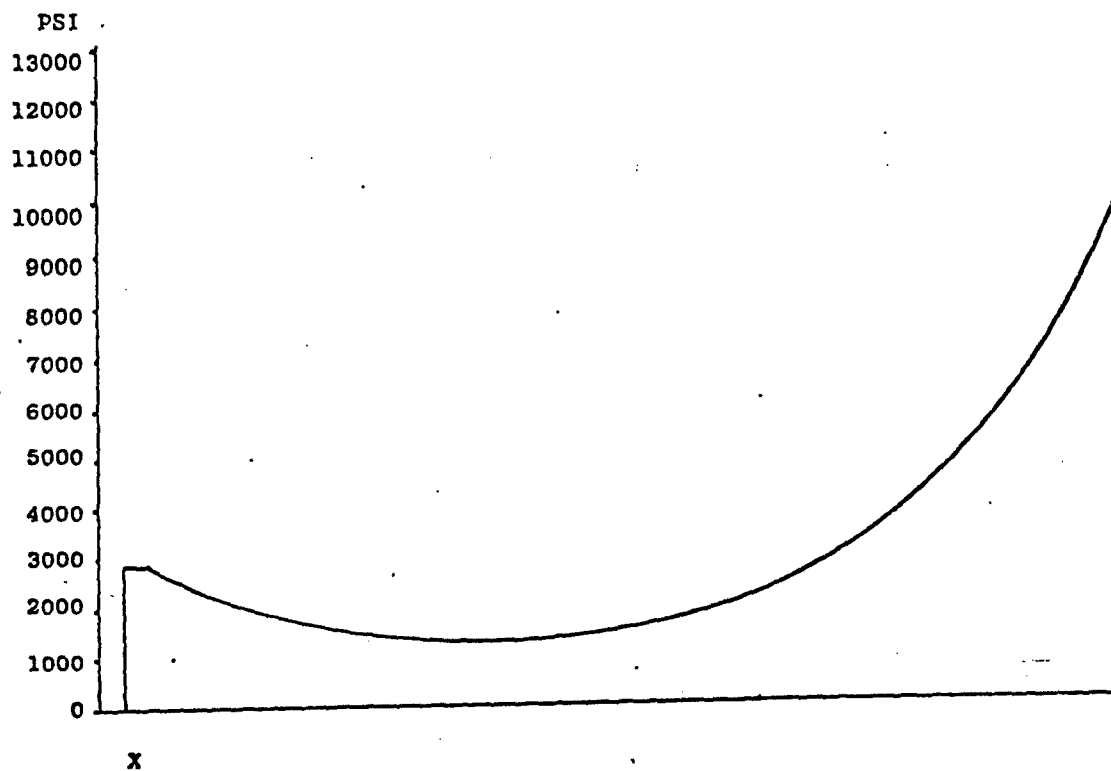
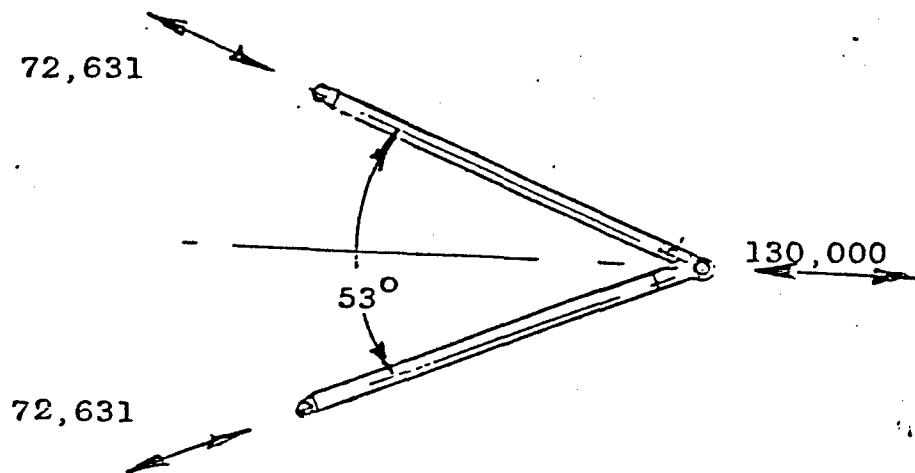

FIGURE 32 - Area Under Curve #1 =
3007.500 psi/in²

3.2 Tow Bar Analysis By Component

The tow bar is the connective element between a towing and a towed vehicle. The design conditions are based on a vehicle gross weight of 120,000 lbs. and a coefficient of friction which does not exceed unity. A margin of 10,000 lbs. was added due to uncertainty of actual vehicle gross weights.

The assumed geometry for this 130,000 lb. load is for a straight pull at a 180° angle between vehicles. No allowance for a differential increase in load in one tube or the other of the tow bar, due to a pulling angle different than a straight pull/push, was considered.



LOADING GEOMETRY

FIGURE 33

As can be seen from the geometry, it is assumed that each leg of the tow bar will take one-half of the 130,000 lb. load or 65,000 lbs. in the direction of vehicle alignment. This works out to a 72,631 lb. (323079 newton) load on each tube in its individual axial direction, after consideration of the 53° included angle between tubes.

3.2.1 Composite Tube Analysis

The composite tube will be considered first. The loads, just given, are a simple condition of axial tension or compression equal to 72,631 lbs.

The tube geometry is:

OD = outside diameter = 4.25 in.

ID = inside diameter = 3.81 in.

I = moment of inertia = $\frac{\pi(OD^4 - ID^4)}{64} = 5.671 \text{ in.}^4$

A = area = 2.785 in.²

L = length = 83-1/2 in. (pin to pin)

E = modulus = 13.46 Psi x 10⁶

First consideration is tube stability. Assuming the tube to be pin ended, the critical load Pcrit is given by:

$$P_{crit} = \frac{\pi^2 EI}{L^2}$$

$$P_{crit} = \frac{\pi^2 (13.46 \times 10^6) (5.671)}{(83-1/2)^2}$$

$$P_{crit} = 108059.2 \text{ lbs.}$$

$$MS = \text{margin of safety} = \frac{108059.2}{72631} - 1 = 49\%$$

Now, considering tube strength, the ultimate compressive stress, Fcu, for this tube is 101,000 Psi. The ultimate compressive load, Pcu, is given by:

$$P_{cu} = F_{cu}A$$

$$P_{cu} = 101,000 \times 2.785$$

$$P_{cu} = 281319 \text{ lbs.}$$

$$MS = \frac{281,319}{(1.5)(72631)} - 1 = 158\%$$

NOTE: 1.5 is the factor of safety

The joint between the composite tube and the metallic end fittings is bridged with a tapered metal sleeve. It is bonded integrally to the tube. This joint is the next consideration.

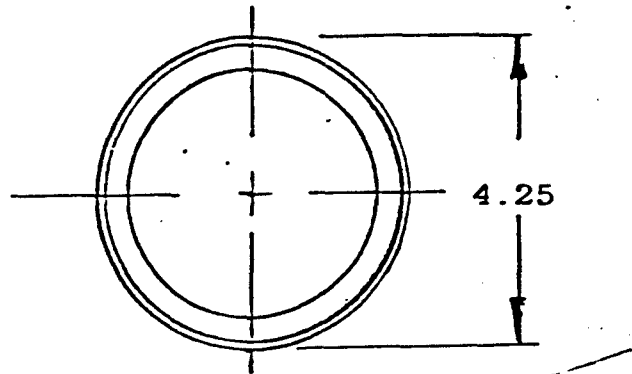

FIGURE 34

The bond length of this single scarf tapered joint is 8.75 inches.

The average diameter of the bonded surface is:

$$\text{Dia. } \frac{4.21 + 4.01}{2} = 4.11 \text{ inches}$$

Therefore, the total available bond area is:

$$\begin{aligned} A_{adh} &= (\pi) (\text{Dia}) \text{ Length} \\ &= (\pi) (4.11) 8.75 \\ &= 112.98 \text{ in.}^2 \end{aligned}$$

Adhesive strength is given by the manufacturer as 2,500 Psi but because of length of the bond and manufacturing uncertainties, a bond strength of 1,000 Psi ultimate shear strength is assumed. Thus, the calculated joint strength is:

$$P_{adh} = F_u, \text{ adhesive} \times \text{Area}$$

$$P_{adh} = (1000) (112.98)$$

$$P_{adh} = 112979.52 \text{ lbs.}$$

$$\text{MS} = \frac{112979.52}{(1.5) (72631)} - 1 = 3.7\%$$

3.2.2 Steel Sleeve

This sleeve, as mentioned, is the bridge between the metallic fittings and the composite tube.

$$\text{OD} = 4.25 \text{ in.}$$

$$\text{ID (Midbody)} = 4.00 \text{ in.}$$

$$A = 1.6198 \text{ in.}^2 \text{ (Midbody)}$$

Material = 4130 Cold Rolled Steel in 'N' Condition

F_{cu} (ultimate compressive strength) = 90,000 Psi

Checking the strength we get:

$$\begin{aligned} P_{\text{sleeve}} &= F_{cu} A \\ &= (90,000) (1.6199) \\ &= 145789 \text{ lbs.} \end{aligned}$$

$$\text{MS} = \frac{145789}{(1.5) (72631)} - 1 = 33.8\%$$

3.3.3 Weld Joint

The steel sleeve is welded to metallic end fittings (lunette or eye). The alloy steel is assumed to have an ultimate tensile strength, F_{tu} , of 51,000 Psi in the weld zone as given by MIL I/BK 5 for a Class 1 welding rod.

$$\text{OD of weld} = 4.25 \text{ in.}$$

$$\text{ID} = 3.89 \text{ in.}$$

This joint has an area of:

$$P_{\text{weld}} = \frac{\pi (\text{OD}^2 - \text{ID}^2)}{4} = 2.3015 \text{ in.}^2$$

$$\begin{aligned} P_{\text{weld}} &= (2.3015) (51000) \\ &= 117378 \text{ lbs.} \end{aligned}$$

$$\text{MS} = \frac{117378}{(1.5) (72631)} = 7.7\%$$

3.3.4 Eye Fitting

This fitting is simply a lug.

Lug Thickness = 1.44 in.

Material = 4140

F_{tu} (ultimate tensile strength) = 125,000 Psi

F_{su} (ultimate shear strength) = 75,000 Psi

F_{bu} (ultimate bearing strength) = 151,000 Psi

First Checking Tension in the Net Section:

Area = $(3.0 - 1.25) 1.44 = 2.52 \text{ in.}^2$

$P_{ten} = F_{tu} \times A$
= $(125,000) (2.52)$
= $(315,000 \text{ lbs.})$

MS = $\frac{315000}{(1.5) (72631) (2)} - 1 = 14\%$
(includes fitting factor of 1.2)

Next Checking Shear Tearout:

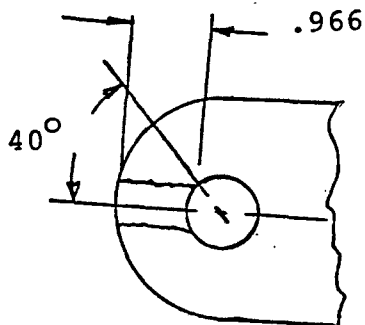

FIGURE 35

$$\text{Area} = (.966) (1.44) (2) = 2.783$$

$$\begin{aligned} P_{\text{Shear}} &= F_{\text{su}}A \\ &= (75,000) (2.783) \\ &= 208,742 \text{ lbs.} \end{aligned}$$

$$\text{MS} = \frac{208742}{(1.5) (1.2) (72631)} - 1 = 60\% \quad (\text{includes fitting factor of 1.2})$$

Checking Bearing:

$$\text{Area} = (1.24) \times 1.44 = 1.785 \text{ in.}$$

$$\begin{aligned} P_{\text{Bear}} &= F_{\text{Bu}}A \\ &= (151,000) 1.785 \text{ in.} \\ &= 269625 \text{ lbs.} \end{aligned}$$

$$\text{MS} = \frac{269625}{(1.5) (1.2) (72631)} - 1 = 106\%$$

3.3.5 Lunette

The lunette provides the confluence point for the tow bar legs and the forward attachment point for the towing vehicle.

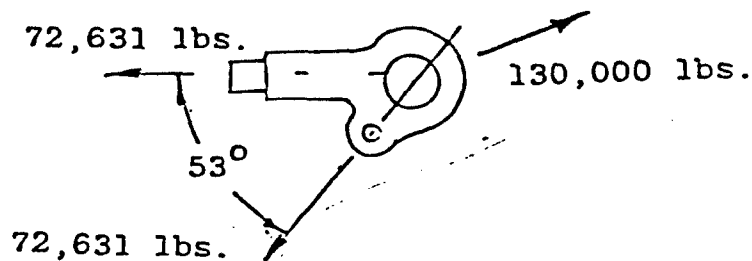

FIGURE 36

Checking the Clevis End of the Lunette:

Material - 4140

Ultimate Tensile Strength - 180,000 - 200,000 Psi

Ultimate Shear Strength - 108,000 Psi

Ultimate Bearing Strength - 250,000 Psi

Lug Thickness - 0.60 in.

First Checking for Tension Across Net Section:

$$\text{Area} = (3.00 - 1.25) (0.60) (2) = 2.10 \text{ in.}^2$$

$$\begin{aligned} P_{\text{tension}} &= F_{tu}A \\ &= (180,000) (2.1) \\ &= 378,000 \end{aligned}$$

$$\text{MS} = \frac{378,000}{(1.5) (1.2) (72631)} - 1 = 189\%$$

Next Checking Shear Tearout:

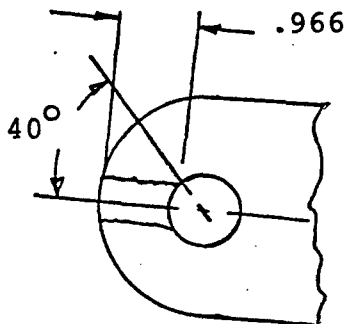

FIGURE 37

$$\text{Area} = 0.966 \times 1.20 \times 2 = 2.32 \text{ in.}^2$$

$$\begin{aligned} P_{\text{Shear}} &= F_{\text{Su}}A \\ &= (108,000) (2.32) \\ &= 250,560 \text{ lbs.} \end{aligned}$$

$$\text{MS} = \frac{226,800}{(1.5) (1.2) (72631)} = 92\%$$

Checking Bearing:

$$\begin{aligned} \text{Area} &= (1.25) \times 1.20 \\ &= 1.50 \text{ in.}^2 \end{aligned}$$

$$F_{\text{BU}} = 250,000 \text{ Psi}$$

$$\begin{aligned} P_{\text{B}} &= F_{\text{Bu}}A \\ &= (250,000) (1.50) \\ &= 375,000 \text{ lbs.} \end{aligned}$$

$$\text{MS} = \frac{375,000}{(1.5) (1.2) (72631)} - 1 = 187\%$$

Next Part of the Lunette to be Analyzed will be the 'Big' Eye:

Checking the Net Section in Tension:

$$\text{Area} = \frac{2 [\pi (1.625^2 - 0.625^2)]}{4} = 3.534 \text{ in.}^2$$

$$\begin{aligned} P_{\text{t}} &= F_{\text{tu}}A \\ &= (180,000) (3.534) \\ &= 636172.5 \text{ lbs.} \end{aligned}$$

$$\text{MS} = \frac{636,172.5}{(1.5) (1.2) (130,000)} = 172\%$$

Next to Check Shear:

$$\text{Area} = 100\% \text{ Heat Treat} = 3.534 \\ (\text{Depth of 1-inch})$$

$$\text{Area} = \text{No Heat Treat} = 0.3058$$

$$P_{\text{Shear}} = (108,000) (3.534) + (70,000) (0.3058) \\ = 403,109$$

$$MS = \frac{403,109}{(1.5) (1.2) (130,000)} = 72\%$$

In order to check bearing of the pintle with the lunette, it is necessary to assume a minimum contact area of part-to-part. The maximum possible bearing contact area is the inner face of the large lunette eye.

$$\text{Maximum Area} = \frac{(1.62)}{2} \frac{(2.81)}{2} = 11.23$$

$$\text{If we assume } 20\% \text{ contact} - 11.23 \times 0.2 = 2.25$$

$$P_{\text{Bearing}} = (F_{\text{BU}}) (A)$$

$$P_{\text{Bearing}} = (219,000) (2.25)$$

$$P_{\text{Bearing}} = 491,874.0$$

$$MS = \frac{491,874.0}{(1.5) (1.2) (130,000)} - 1 = 110\%$$

3.3.6 Clevis

Finally, the clevis must be checked. This fitting is really a double clevis. The end toward the tow bar is a simple set of lugs.

First, the lug will be checked for tension across the net section. The material is 4140 heat treated to 180,000 Psi - 200,000 Psi. The net tension area is actually the area of the plane thru the hole centerline normal to the load but for the purpose of calculation is conservatively assumed to be twice the minimum area at the 1.15 dimension.

The Area is:

$$A = 2(1.15 - .62) (1.20) = 1.26 \text{ in.}^2$$

$$P_t = F_{tu}A$$

$$P_t = (180,000) (1.26)$$

$$P_t = 226,800$$

$$MS = \frac{226,800}{(1.5) (1.2) (72631)} - 1 = 73\% \quad (\text{includes a fitting factor of 1.2})$$

Shear Check:

The Shear Area is:

$$A = (4) (1.39 - 0.625) (0.60) = 1.836 \text{ in.}^2$$

$$P_{su} = F_{su}A$$

$$= (108,000) (1.836)$$

$$= 198,288 \text{ lbs.}$$

$$MS = \frac{198,288}{(1.5) (1.2) (72631)} - 1 = 52\% \quad (\text{includes a fitting factor of 1.2})$$

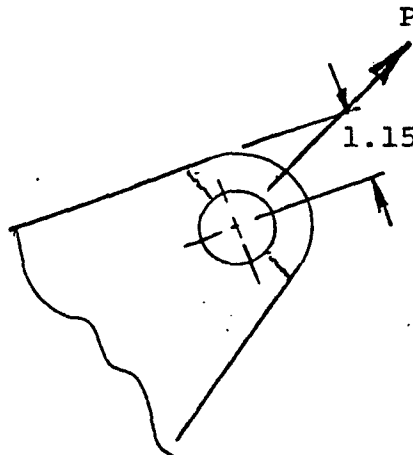

FIGURE 38

Now to look at the opposite end; the tank attach clevis. The load as applied to this end causes a side load in the lugs and thus bending in the lug as shown below.

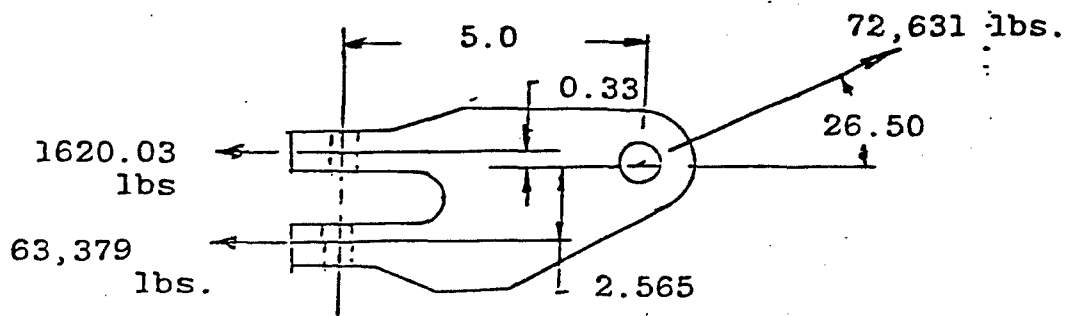

FIGURE 39

First checking the outer leg of the clevis:

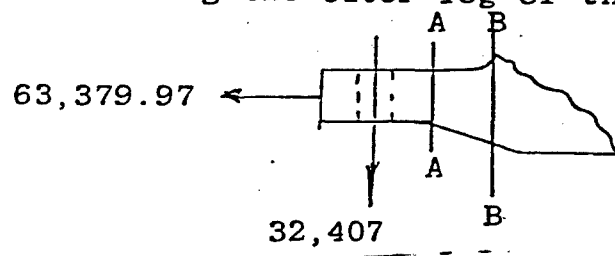

FIGURE 40

Tension in the Net Section:

$$\begin{aligned} \text{Area} &= (3.0 - 1.50) (1.15) \\ &= 1.7250 \text{ in.}^2 \end{aligned}$$

$$\begin{aligned} P_T &= (180,000) (1.7250) \\ &= 310,500 \text{ lbs.} \end{aligned}$$

$$MS = \frac{310,500}{(1.5) (1.2) (63381.35)} - 1 = 172\%$$

Shear Out of Pin:

$$\begin{aligned} \text{Area} &= 2 (1.50 - .75) (1.15) \\ &= 1.725 \text{ in.}^2 \end{aligned}$$

$$\begin{aligned} P_{Su} &= F_{Su} A \\ &= (108,000) (1.725) \\ &= 186,300 \text{ lbs.} \end{aligned}$$

$$MS = \frac{186,300}{(1.5) (1.2) (63381.35)} - 1 = 63\%$$

Now Checking Stress at Section A-A:

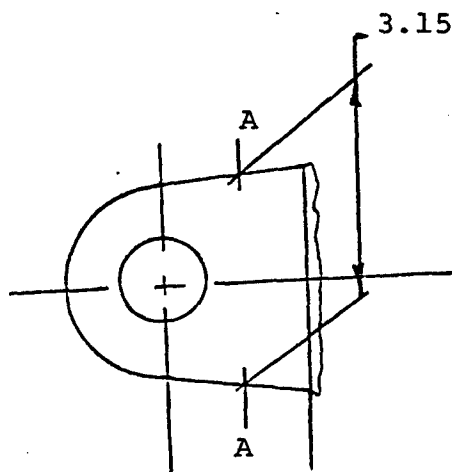

FIGURE 41

$$\begin{aligned} \text{Area} &= (3.15) (1.15) \\ &= 3.6225 \text{ in.}^2 \end{aligned}$$

$$\sigma_{\text{Total}} = \sigma_T + \sigma_B$$

$$\sigma_T = \frac{P_t}{A} = \frac{63381.35}{3.62} = 17496.6 \text{ Psi average stress}$$

$$\begin{aligned} \sigma_B &= \frac{6M_2}{bh} = \frac{6(32407.8) (1.03)}{3.15 (1.15)} \\ &= 48076.4 \text{ Psi peak stress due to bending} \end{aligned}$$

$$\begin{aligned} \sigma_{\text{Total}} &= 65573 \text{ Psi due to bending, plus } 17496.6 \text{ Psi average stress} \\ &= 180,000 \text{ Psi} \end{aligned}$$

$$\text{MS} = \frac{180,000}{(65573) (1.5) (1.2)} - 1 = 53\%$$

Similarly checking Section B-B:

$$\text{Area} = 3.32 \times 1.48 = 4.9136 \text{ in.}^2$$

$$\begin{aligned} \sigma_T &= \frac{P_t}{A} = \frac{63381.35}{4.9136} \\ &= 12899.17 \text{ Psi average stress} \end{aligned}$$

$$\begin{aligned} \sigma_B &= \frac{6M_2}{bh} = \frac{6(32407) (2)}{3.32 (1.48)} \\ &= 53477.28 \text{ Psi peak stress due to bending} \end{aligned}$$

$$\text{Total} = 66376.45$$

$$\text{MS} = \frac{180,000}{(66376.45) (1.5) (1.2)} - 1 = 51\%$$

Next, check the Inner Leg of the Clevis:

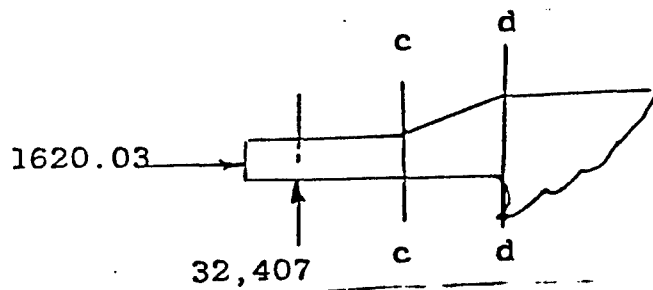

FIGURE 42

Tension in Net Section:

$$\begin{aligned} \text{Area} &= (3.0 - 1.5) 1.0 \text{ in.}^2 \\ &= 1.50 \text{ in.}^2 \end{aligned}$$

$$P_t = 1.50 \text{ in.}^2 \times 180,000 = 270,000 \text{ lbs.}$$

$$\text{MS} = \frac{270,000}{1618.65 \times 1.5 \times 2} - 1 = 5,460\%$$

Shear Out of Pin:

$$\begin{aligned} \text{Area} &= 2(1.50 - 0.75) 1.0 \\ &= 1.50 \text{ in.}^2 \end{aligned}$$

$$\begin{aligned} P_{su} &= F_{su} A \\ &= (108,000) (1.50) \\ &= 162,000 \text{ lbs.} \end{aligned}$$

$$\text{MS} = \frac{162,000}{1618.65 \times 2 \times 1.5} - 1 = 3,236\%$$

Now checking Section C-C:

$$\begin{aligned}\text{Area} &= (3.15) (1.0) \\ &= 3.15 \text{ in.}^2\end{aligned}$$

$$\sigma_{\text{Total}} = \sigma_t = \sigma_B$$

$$\sigma_t = \frac{P_t}{A} = \frac{1618.65}{3.15} = 513.86 \text{ Psi}$$

$$\sigma_B = \frac{6M_2}{bh} = \frac{6 (32407) (1.03)}{(3.15) (1.0)^2}$$

$$\sigma_B = 63581.03 \text{ Psi peak fiber stress due to bending}$$

$$\text{Total} = 64095 \text{ Psi}$$

$$\text{MS} = \frac{180,000}{(64095) \times (1.5) (1.2)} - 1 = 56\%$$

Finally, checking Section D-D:

$$\begin{aligned}\text{Area} &= (3.32) (1.33) \\ &= 4.4156 \text{ in.}^2\end{aligned}$$

$$\sigma_{\text{Total}} = \sigma_t + \sigma_B$$

$$\sigma_t \text{ due to tension} = \frac{1618.65}{4.4156 \text{ in.}} = 366.6 \text{ Psi}$$

$$\begin{aligned}\sigma_B &= \text{peak stress due to bending} \\ &= \frac{6 \times 32407.8 \times 2}{3.32 \times (1.33)^2} = 66220 \text{ Psi}\end{aligned}$$

$$\text{Total} = 66586.62 \text{ Psi}$$

$$\text{MS} = \frac{180,000}{(66586.62) (1.5) (1.2)} - 1 = 50\%$$

4.0 FABRICATION

The prototype lightweight tow bar fabrication processes were chosen to fit the limited number of parts being produced. The final product is representative, however, of what a more efficient high production process would produce.

4.1 Metallic Fittings

The lug-type fittings were made as machinings from plate and bar stock of high quality military specification 4130 steel. In production, these parts would probably be near net forgings which might be finish machined in the lug area. Heat treatment of the production parts, however, would be identical to the prototype parts, (i.e., 180,000 - 200,000 PSI or 1.24×10^3 to 1.38×10^3 MPa).

The sleeves are tubular steel machined to length with an internal step and taper. No heat treatment was called out for this part.

4.2 Composite Tube

The fabrication sequence for the composite tube is shown in Figure 43. This is a two-part process.

4.2.1 Kevlar Sheath. The sheath is made first, as it later acts as an external mandrel for the graphite/epoxy material. The process chosen for the sheath is roll-wrapping of Kevlar woven fabric preimpregnated with resin. Roll-wrapping yields a quality part with dimensionally controlled inside diameter and is a simple low cost process.

The roll wrap process (shown in Figure 43) is a mechanical procedure to deposit sheets of preoriented material onto a mandrel. The application of temperature and pressure assures good compaction as the material is deposited. The upper platen of the rolling machine is lowered by an air operated piston to make contact with the male mandrel and

exert mandrel pressure on the edge of the prepreg pattern. The bed or bottom platen of the rolling table traverses so as to cause rotation of the male mandrel thereby rolling up the prepreg. This is accomplished while maintaining pressure between the upper platen and the lower platen, so as to deposit the material in a uniform and compacted manner.

ROLL WRAP PROCESS

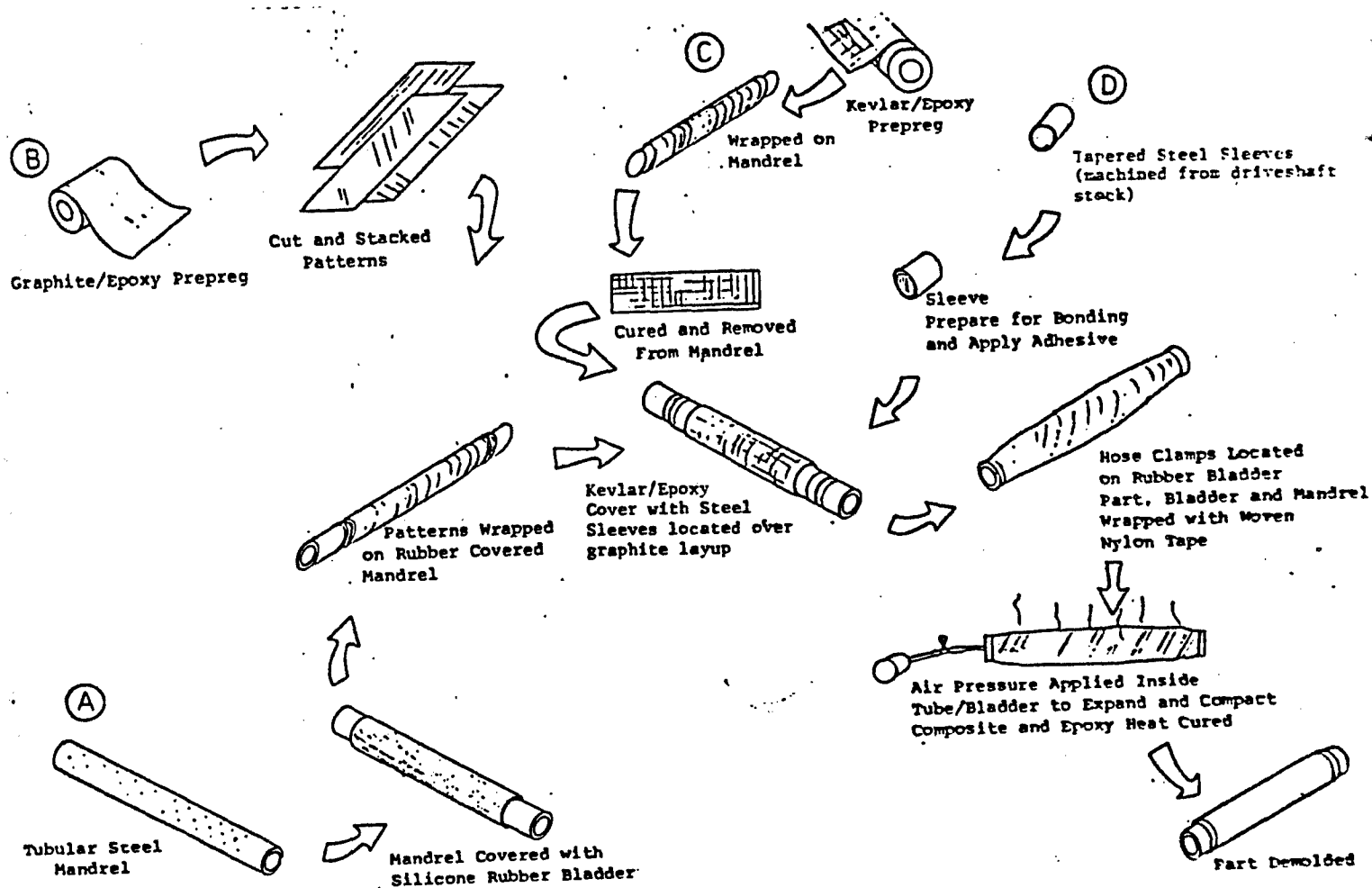

FIGURE 43 - Composite Tube Manufacturing Sequence

Figure 44 shows a sheath trimmed to length; ready for the next fabrication step.

4.2.2 Graphite/Epoxy Lay-Up. The mandrel for the graphite/epoxy lay-up is slightly undersized. It is covered by an expandable bladder which has internal pressure fittings. The unidirectional prepreg graphite/epoxy is laid-up on the mandrel according to the ply orientation call out on the drawing.

The first and last plies of the lay-up are at angles of $\pm 45^\circ$ which give the lay-up integrity prior to curing.

The mandrel with the laid-up graphite/epoxy is inserted into the Kevlar sheath. The metallic sleeves receive the adhesive coating on the portion of the innersurface which contacts the graphite/epoxy. The sleeves are then inserted into the sheath over the graphite/epoxy covered mandrel.

Pressure is applied to the bladder over the mandrel and the graphite/epoxy prepreg is forced out against the sheath and metallic sleeves. Heat is applied according to the precalculated cure cycle, and the graphite/epoxy material is cured under pressure in place against the sheath and simultaneously bonded to the metallic sleeve. Figure 45 shows a completed program set of composite tubes.

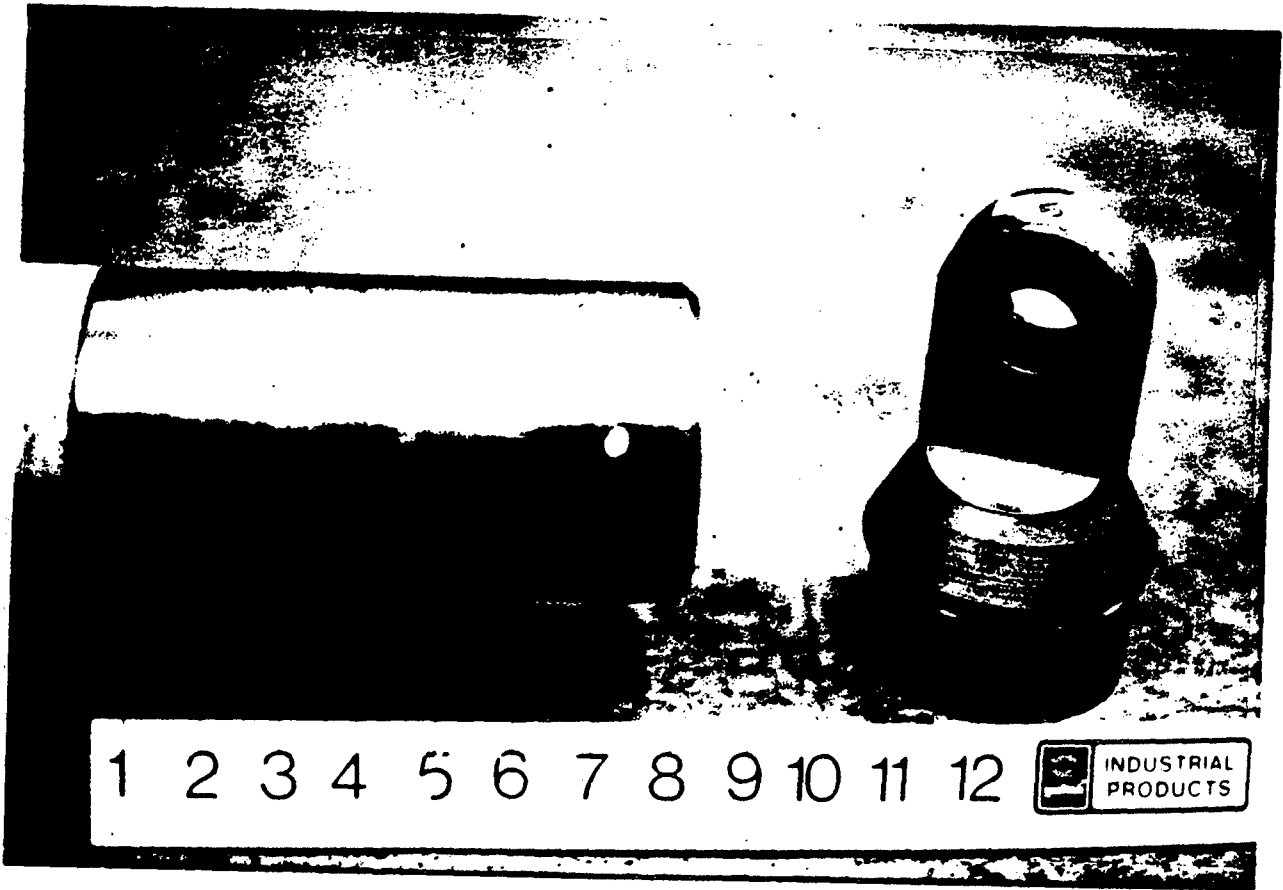

FIGURE 44 - Sheath Trimmed to Length



FIGURE 45 - Unidirectional Prepreg on Mandrel

Summarizing the fabrication procedure is the sequence of steps presented below:

- a. Deposit Kevlar woven prepreg on the male mandrel by roll wrapping.
- b. Cure under heat and pressure applied by Tedlar film.
- c. Deposit graphite/epoxy unidirectional material on bladder covered undersize mandrel.
- d. Apply adhesive to metallic sleeves.
- e. Insert graphite/epoxy covered mandrel into cured sleeve.
- f. Insert metallic sleeves with adhesive into Kevlar sheath over graphite/epoxy.
- g. Inflate bladder of sub-size mandrel to expand graphite/epoxy prepreg against sheath and sleeves.
- h. Cure with heat and pressure.
- i. Deflate bladder and remove bladder and mandrel.

An example of an actual process document is included in Appendix A.

4.3 Weld Assembly

There are actually two weld assemblies -- the tube and eye assembly and the tube and lunette assembly. The first assembles a composite tube complete with sleeves and two eye fittings. The second assembles a composite tube with sleeves, and eye fitting and a lunette fitting.

The process, however, is the same for each. The end fittings (either eye or lunette) are inserted into the sleeve of the composite tube at each of the tubes ends. Figure 44 shows an eye fitting ready for welding. The length is verified and a tack weld made through the holes in the sleeve. The length of the assembly is re-verified and the circumferential welds made around the sleeve-to-fitting junction.

Finally, the four puddle welds are finished.

4.4 Final Assembly

All parts are cleaned, prepared for painting and painted per drawing specifications. The parts are brought together per Top Assembly Drawing Number 1000 and pinned in place. A complete tow bar is shown in Figure 45.

Copies of the drawings are found in the Appendix A. These drawings are listed below:

<u>EEMD No.</u>	<u>Title</u>
100000	Tow Bar Assembly -Lightweight
100001	Tube & Eye Assembly - Tow Bar
100002	Tube & Lunette Assembly - Tow Bar
100003	Composite Tube Assembly - Tow Bar
100004	Clevis, Tow Bar
100005	Sleeve, Tow Bar
100006	Lunette, Tow Bar
100007	Eye, Tow Bar
100008	Clevis Pin, Small
100009	Clevis Pin, Large

A copy of an actual process sheet is found in Appendix E.

5.0 TESTING

Testing for the Tow Bar Program is divided into four categories:

- a. Material Testing
- b. Joint Tests
- c. Design Verification
- d. Non-Destructive Testing

5.1 Material Testing

Tests were conducted on the structural composite materials -- graphite/epoxy and the adhesive.

5.1.1 Graphite/Epoxy. For quality control purposes, material properties are verified by material lot when received. To be used, the material tested must meet specification minimums. These minimums for high strength graphite/epoxy are:

Material Tests Used

Flexural Property	ASTM D740
Horizontal Shear	ASTM D2344
Tensile Properties	ASTM D3039
Compression Properties	ASTM D3410

The data from the material tests are shown in Appendix B.

5.1.2 Adhesive Testing. Tests were conducted on all the candidate adhesives to find the best. The adhesives tested were those recommended by both EEMD's fabrication staff and outside sources as being suitable for a steel to graphite/epoxy joint. These tests were conducted on a lap shear specimen using steel as one adherend and high strength graphite/epoxy as the other. With these adherends, the tests yielded allowable stress data more meaningful than the standard vendor data. The results from these tests are shown in Appendix B.

Two adhesives were chosen for further consideration during the joint tests - Narmco Metalbond 1133 and 3M AF 13. Our tests actually had slightly better results than vendor data for similar, although singular, material adherend tests.

5.2 Joint Tests

Prior to finalizing the design drawings, the proposed design for the joint was fabricated using production tooling. The part duplicated the materials and geometry in the area of the joint but it was not a full tube assembly. Also, fiberglass was substituted for Kevlar in the sheath.

The test was conducted on one-inch sections cut from the joint specimen. The test conditions are felt to be more severe than the joint will see in service, where the joint is a continuous tube which tends to resist any off-center loading moments. A sufficient length (16 inches) was allowed for the test, to prevent influence from the jaws of the test machine. Pads were added at the jaws to prevent problems. No effects due to the substitution of fiberglass for Kevlar were felt, because no bond between the steel and the sheath was made.

The results of the test show that the adhesives will withstand more than the design load in the joint configuration. The most important aspect of the joint test, however, was not a function of the adhesive. Almost all of the joint specimens failed -- not in the joint -- but in the laminate. A close examination of the test specimen showed that the interior $+ 45^\circ$ layers of graphite/epoxy prepreg has "wrinkled" during the lay-up or pressurization, and were "prebuckled". This condition caused a local premature failure. As a result of the joint test, the laminate was changed to put these plies on the outside.

Examination of the new ply laminate showed that the wrinkling problem has been corrected. These results of the joint test are shown in Appendix C.

Both of the adhesives used in the joint tests were utilized in the final design. Metalbond 1133 was used in the interior of the tapered lap joint and 3M AF 13 was used at the joint extremes. (See the finite element analysis section for an explanation of this).

This dual adhesive approach was used on the design verification tube sent to TACOM for testing.

5.3 Design Verification

After design approval, TACOM was supplied with one item which consisted of the composite tube and the metallic sleeve.

This tube was to be tested in tension and compression to verify the design. In compression, the tube survived a load 127% greater than the design load. The tube was never fully tested in tension, due to fixture problems. Nevertheless, this test item did yield valuable proof that the process would produce a structurally sound part. The limited testing showed that the part was capable of meeting the critical strength criteria -- Euler buckling stability. (See Figure 3).

5.4 Non-Destructive Testing

Ultrasonic C-Scan was chosen as the technique for non-destructive evaluation. As with all NDT, an operator evaluates the specimen and compares it to a test standard or standards. A set of standards for the tow bar laminates was fabricated. Some of the laminates were built with intentional defects of a known size, and a spectrum of possible defects and results were defined.

Some problems were encountered due to the fabrication sequence which uses the Kevlar sheath as an internal mandrel to form the graphite/epoxy tube integral with the metallic sleeve. In the area of the sleeve-to-graphite/epoxy joint, the sleeve and graphite/epoxy became an integral composite part. This allowed good sound transmission and good part definition with the C-Scan unit. In the area of the metallic sleeve, however, no attempt to bond the sleeve to the sheath was made. Because of this, the area between the sheath and the metal sleeve looks like an unbonded area and blanks out the rest of the material. After a great deal of study and trial and error, the C-Scan operator could 'read' these areas and separate out these 'voidy' regions. The results of the C-Scan studies showed that in all four tubes, no significant flaws existed. The C-Scan plots are reproduced in Appendix D.

5.5 Field Testing

Field testing of the two tow bars was conducted at Aberdeen Proving Grounds, MD., on paved, secondary, and cross-country roads. The results of this test were documented in TACOM Project No. 1-VC-080-060-123, Report No. AP6-MT-5578.

ADDENDUM

APPENDIX A

DRAWINGS

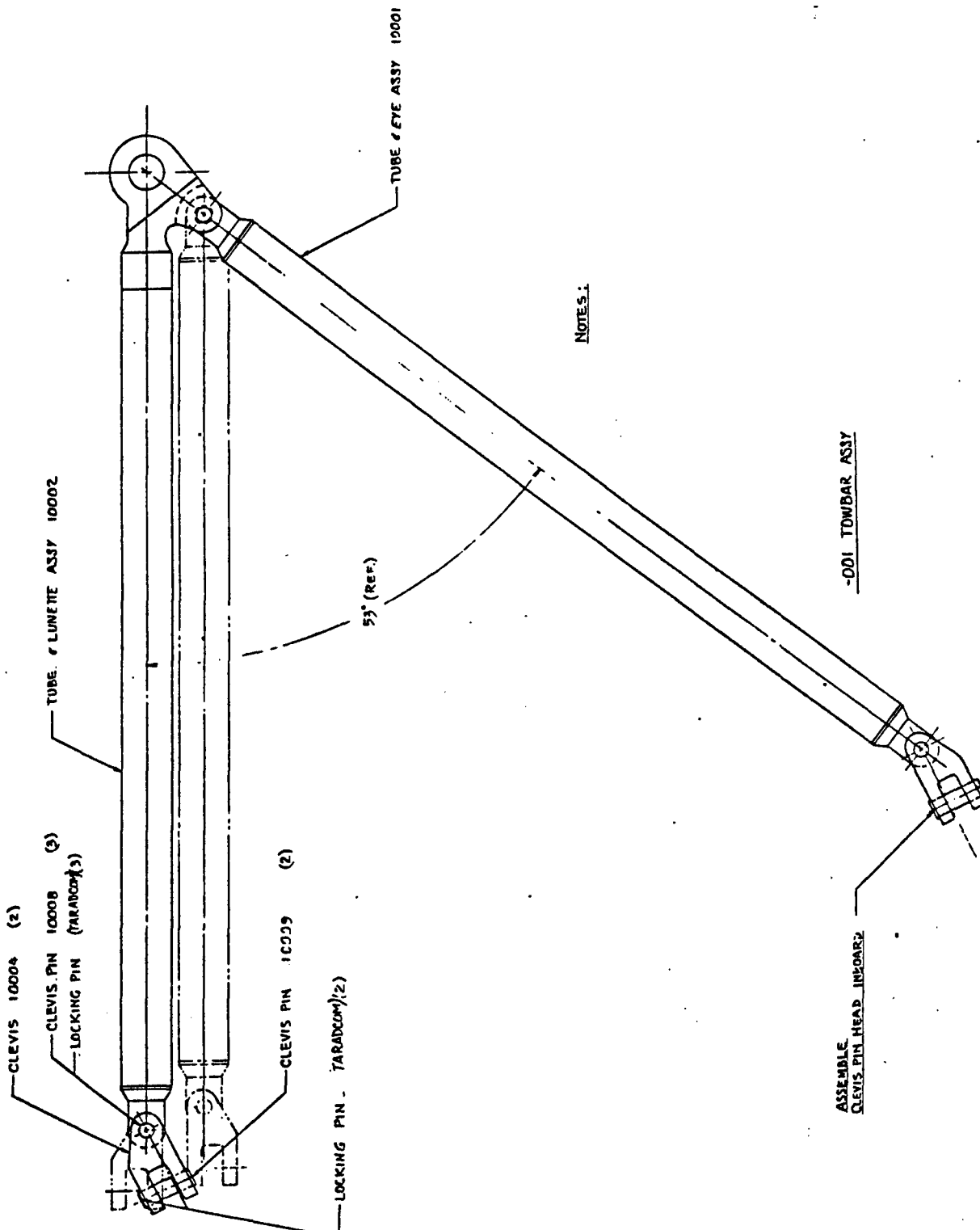

1	COILS, P-V	TARADCOM
2	10005 CLEVIS BUSHING	
3	10006 CLEVIS BUSHING	
4	10007 CLEVIS BUSHING	
5	10008 CLEVIS PIN	
6	10009 CLEVIS PIN	
7	10010 TUBE & LUNETTE ASSY	
8	10011 TUBE & EYE ASSY	
9	10012 TUBE & EYE ASSY	
10	10013 TUBE & EYE ASSY	
11	10014 TUBE & EYE ASSY	
12	10015 TUBE & EYE ASSY	
13	10016 TUBE & EYE ASSY	
14	10017 TUBE & EYE ASSY	
15	10018 TUBE & EYE ASSY	
16	10019 TUBE & EYE ASSY	
17	10020 TUBE & EYE ASSY	
18	10021 TUBE & EYE ASSY	
19	10022 TUBE & EYE ASSY	
20	10023 TUBE & EYE ASSY	
21	10024 TUBE & EYE ASSY	
22	10025 TUBE & EYE ASSY	
23	10026 TUBE & EYE ASSY	
24	10027 TUBE & EYE ASSY	
25	10028 TUBE & EYE ASSY	
26	10029 TUBE & EYE ASSY	
27	10030 TUBE & EYE ASSY	
28	10031 TUBE & EYE ASSY	
29	10032 TUBE & EYE ASSY	
30	10033 TUBE & EYE ASSY	
31	10034 TUBE & EYE ASSY	
32	10035 TUBE & EYE ASSY	
33	10036 TUBE & EYE ASSY	
34	10037 TUBE & EYE ASSY	
35	10038 TUBE & EYE ASSY	
36	10039 TUBE & EYE ASSY	
37	10040 TUBE & EYE ASSY	
38	10041 TUBE & EYE ASSY	
39	10042 TUBE & EYE ASSY	
40	10043 TUBE & EYE ASSY	
41	10044 TUBE & EYE ASSY	
42	10045 TUBE & EYE ASSY	
43	10046 TUBE & EYE ASSY	
44	10047 TUBE & EYE ASSY	
45	10048 TUBE & EYE ASSY	
46	10049 TUBE & EYE ASSY	
47	10050 TUBE & EYE ASSY	
48	10051 TUBE & EYE ASSY	
49	10052 TUBE & EYE ASSY	
50	10053 TUBE & EYE ASSY	
51	10054 TUBE & EYE ASSY	
52	10055 TUBE & EYE ASSY	
53	10056 TUBE & EYE ASSY	
54	10057 TUBE & EYE ASSY	
55	10058 TUBE & EYE ASSY	
56	10059 TUBE & EYE ASSY	
57	10060 TUBE & EYE ASSY	
58	10061 TUBE & EYE ASSY	
59	10062 TUBE & EYE ASSY	
60	10063 TUBE & EYE ASSY	
61	10064 TUBE & EYE ASSY	
62	10065 TUBE & EYE ASSY	
63	10066 TUBE & EYE ASSY	
64	10067 TUBE & EYE ASSY	
65	10068 TUBE & EYE ASSY	
66	10069 TUBE & EYE ASSY	
67	10070 TUBE & EYE ASSY	
68	10071 TUBE & EYE ASSY	
69	10072 TUBE & EYE ASSY	
70	10073 TUBE & EYE ASSY	
71	10074 TUBE & EYE ASSY	
72	10075 TUBE & EYE ASSY	
73	10076 TUBE & EYE ASSY	
74	10077 TUBE & EYE ASSY	
75	10078 TUBE & EYE ASSY	
76	10079 TUBE & EYE ASSY	
77	10080 TUBE & EYE ASSY	
78	10081 TUBE & EYE ASSY	
79	10082 TUBE & EYE ASSY	
80	10083 TUBE & EYE ASSY	
81	10084 TUBE & EYE ASSY	
82	10085 TUBE & EYE ASSY	
83	10086 TUBE & EYE ASSY	
84	10087 TUBE & EYE ASSY	
85	10088 TUBE & EYE ASSY	
86	10089 TUBE & EYE ASSY	
87	10090 TUBE & EYE ASSY	
88	10091 TUBE & EYE ASSY	
89	10092 TUBE & EYE ASSY	
90	10093 TUBE & EYE ASSY	
91	10094 TUBE & EYE ASSY	
92	10095 TUBE & EYE ASSY	
93	10096 TUBE & EYE ASSY	
94	10097 TUBE & EYE ASSY	
95	10098 TUBE & EYE ASSY	
96	10099 TUBE & EYE ASSY	
97	10100 TUBE & EYE ASSY	
98	10101 TUBE & EYE ASSY	
99	10102 TUBE & EYE ASSY	
100	10103 TUBE & EYE ASSY	

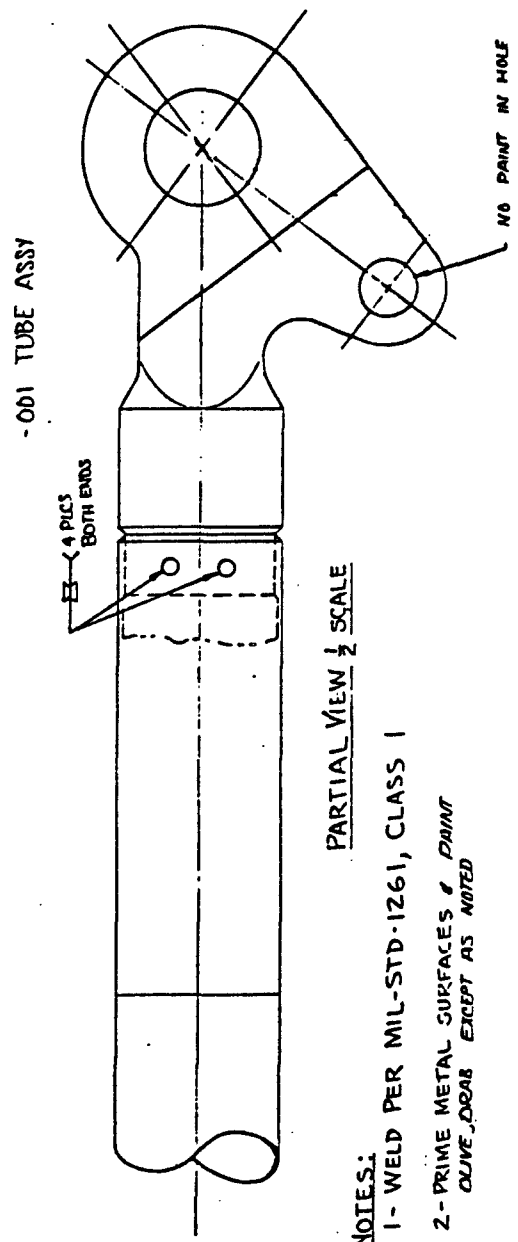
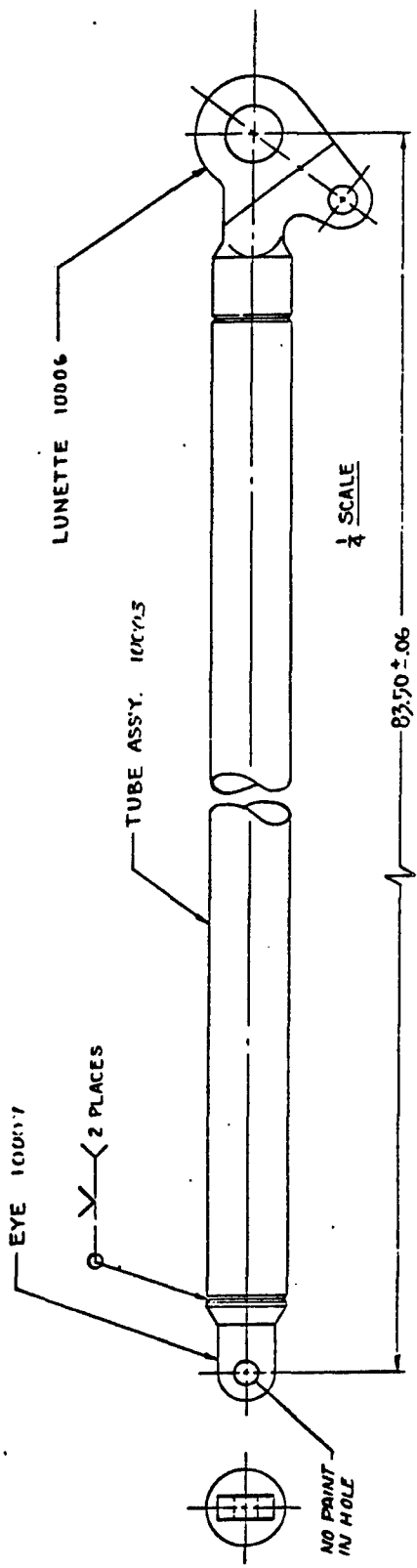

NOTES:
 1- WELD PER MIL-STD-1261, CLASS 1
 2- PRIME METAL SURFACES & PAINT
 OLIVE DRAB EXCEPT AS NOTED

ITEM NO	1	1000Z	EYE
	1	1000Z	LUNETTE
	1	1000Z	TUBE ASSY
DESCRIPTION	MATERIAL, STOCK SIZE, VENDOR		
PARTS LIST			
SIGNATURE	DATE	FIG. NO.	REV.
CH	1/1/59	1000Z	1
QC			
SCALE	NOTED	RELEASED	SHEET 1 OF 1

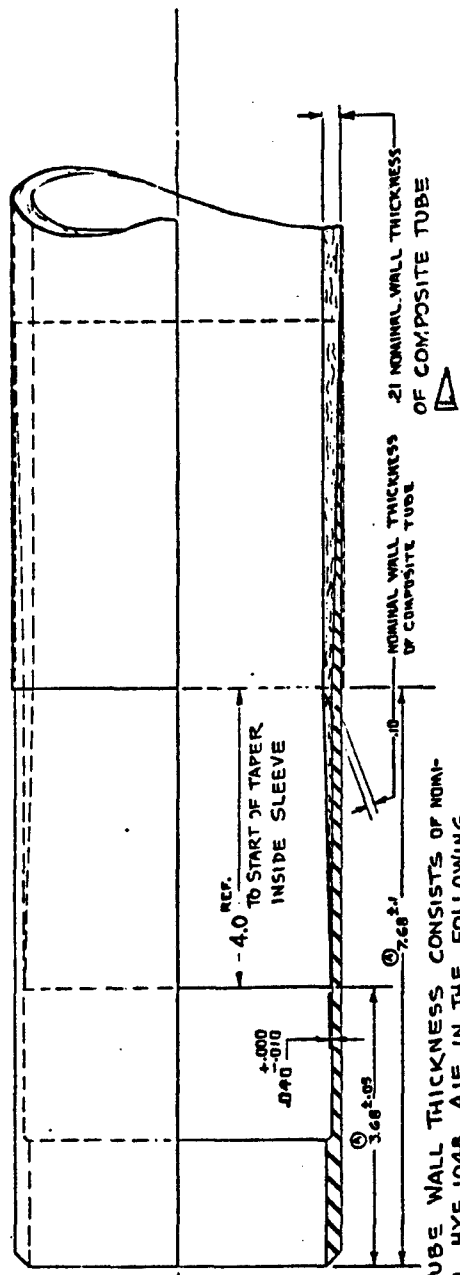
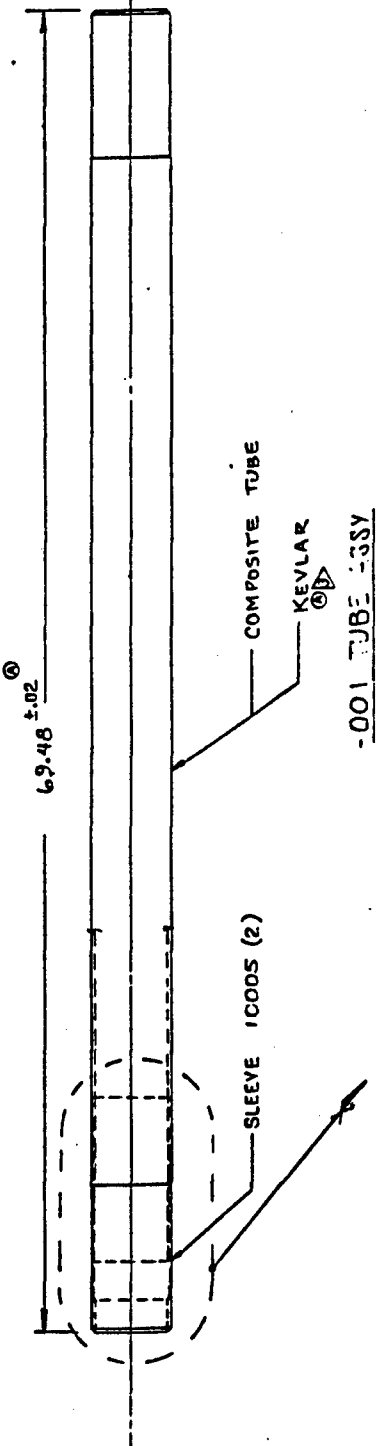

NOTES:

- ① COMPOSITE TUBE WALL THICKNESS CONSISTS OF NOMINAL .21 INCH HYE 1048 AIE IN THE FOLLOWING ORIENTATION : $\begin{bmatrix} 45^\circ & 2/0^\circ & 28/145^\circ & 2 \end{bmatrix}$
- 2- APPLY ADHESIVE BETWEEN STEEL SLEEVES
- ④ COMPOSITE LAYUP AS FOLLOWS 2.0 ±.05 WIDE BAND OF 3M-AF-B AT SLEEVE TIP, 1.0 ±.03 WIDE BAND OF 3M-AF-B AT COMPOSITE TIP, REMAINDER GMS 2000.
- ③ GRAPHITE - STEEL ASSY. TO BE OVERWRAPPED WITH 4 PLYS OF KEVLAR FABRIC WITH 0/90° ORIENTATION.
- 4- NEXT ASSY - 10001, 10002
- ⑤ SEAL METAL TO KEVLAR AS REQ'D.

ITEM NO	DESCRIPTION	MATL	STOCK SIZE	REWORK
1	ADHESIVE			
2	COMPOSITE TUBE			
PARTS LIST				
DATE	BY	REVISION	DATE	BY
10/05				
DRAWING DATA				
DESIGNED BY	DATE	SCALE	PROJECT	
DRN	DATE			
CHK	DATE			
APP	DATE			
DC	DATE			
DRAFTED BY: BRADY BRIDGES DESIGN ENTERPRISES INC BALETON, NORTH CAROLINA 27815 COMPOSITE TUBE ASSY. TOWBAR				
SCALE	1:1	DATE	10/03	REV
SCALE NOTED	RELEASED	SHEET	1	OF

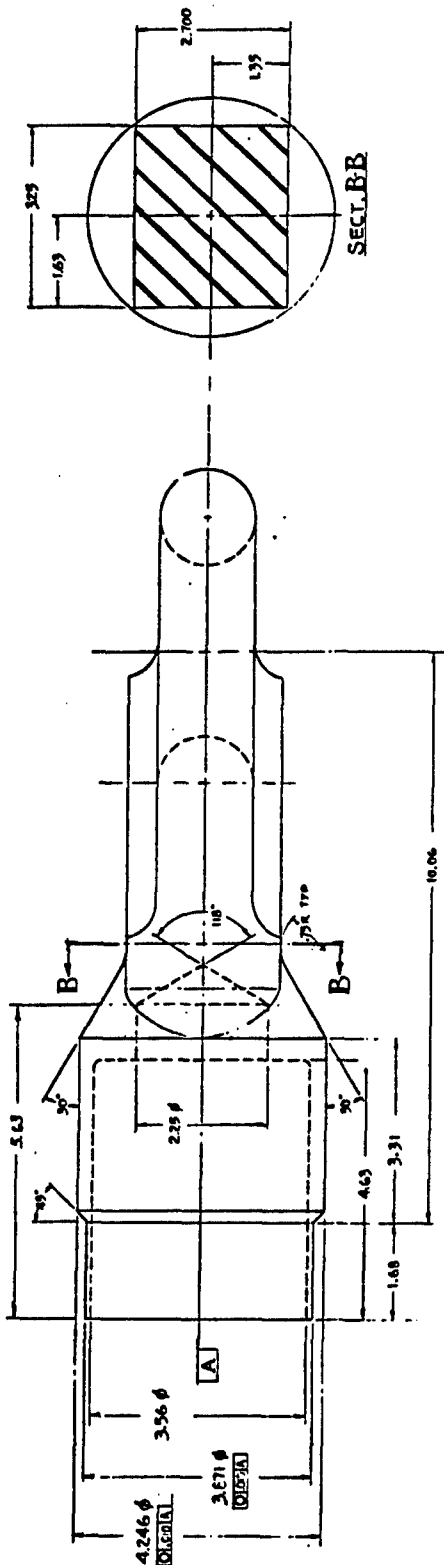

PICTORIAL VIEW
NO SCALE

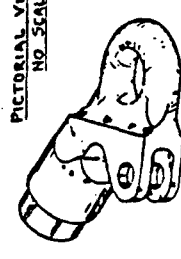

- NOTES:
- 1 - MAT'L - STEEL #4140 (MIL-S-5626)
 - 2 - HEAT TREAT TO TENSILE STRENGTH OF 180,000/200,000 PSI
 - 3 - LIQUID PENETRANT INSPECTION .001 REQD PER MIL-STD-105
 - 4 - ALL SURFACES TO BE R_A UNLESS OTHERWISE SPECIFIED
 - 5 - BREAK SHARP EDGES
 - 6 - NEXT ASSY - 10002

PART LIST		QUANTITY		REVISION	
001	LUNETTE	1		1	
PARTS LIST		QUANTITY		REVISION	
001	LUNETTE	1		1	
MATERIAL		QUANTITY		REVISION	
001	STEEL #4140	1		1	
DRAWING DATA		QUANTITY		REVISION	
TITLE		QUANTITY		REVISION	
LUNETTE, TOW BAR		10000		1	

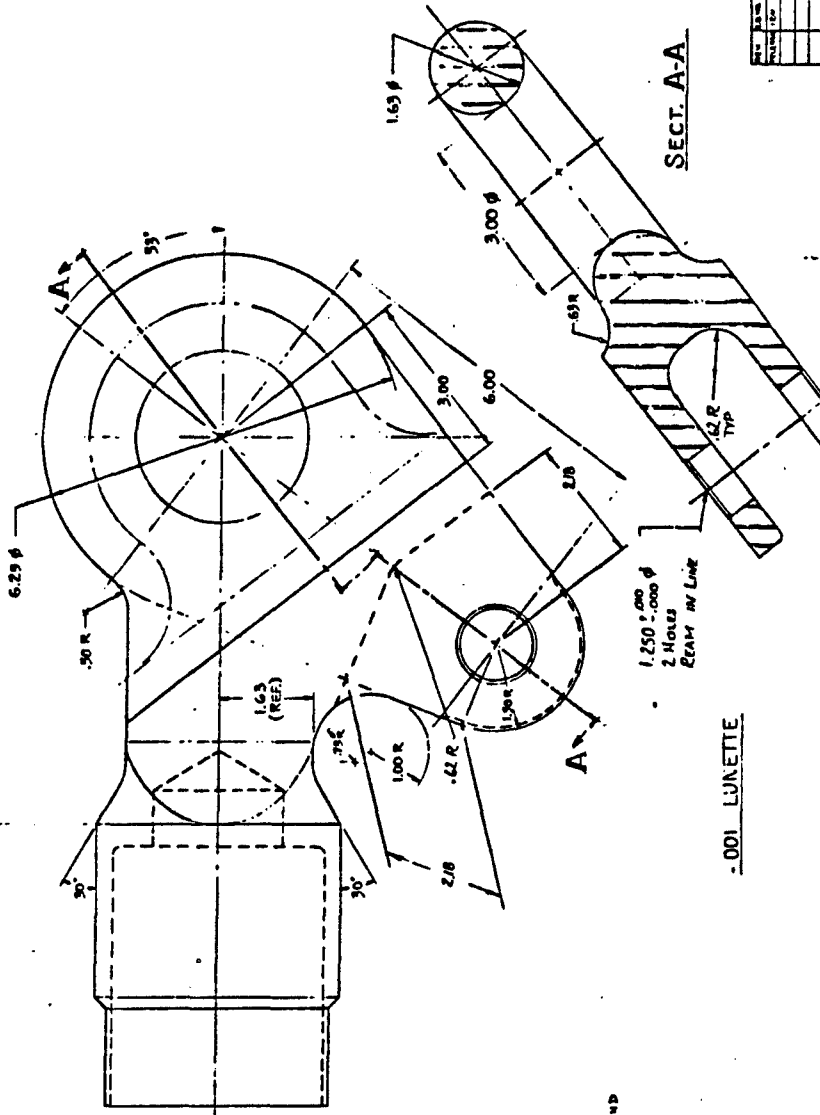

SECT. A-A

SECT. B-B

- 001 LUNETTE

A-8

.06 x 45° (±)
APPROX. 180° AROUND

.03 x 45° (±)

1.500

.75

1.35 REF.

2.700

2.700

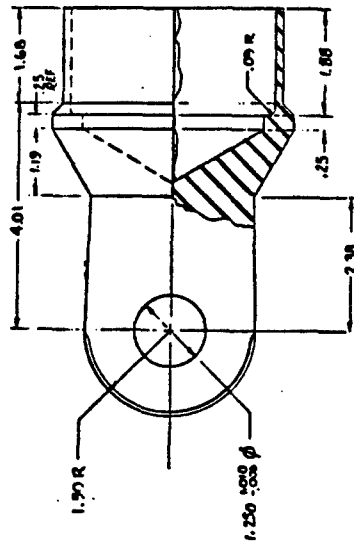
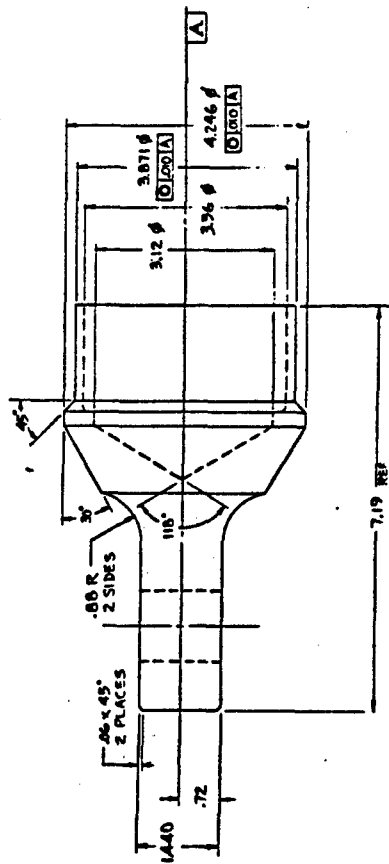

-001 EYE

NOTES:

- 1- MAT'L. - STEEL #4140 (MIL-S-9626)
- 2- HEAT TREAT TO TENSILE STRENGTH OF 180,000/200,000 PSI.
- 3- LIQUID PENETRANT INSPECTION .001 REQ'D PER MIL-T-686 - *NO DATA AVAILABLE*
- 4- ALL SURFACES TO BE $\sqrt{15}$ UNLESS OTHERWISE SPECIFIED.
- 5- BREAK SHARP EDGES.
- 6- NEAT ASSY - 10001, 10002.

PARTS LIST		QUANTITY		UNIT PRICE		TOTAL PRICE	
QTY	DESCRIPTION	QTY	UNIT PRICE	QTY	UNIT PRICE	QTY	UNIT PRICE
1	EYE						
PARTS LIST QUANTITY UNIT PRICE TOTAL PRICE 10001 10002 10007							

APPENDIX B

MATERIAL TESTS

1. Graphite Epoxy
2. Adhesive

HIGH-STRENGTH GRAPHITE-EPOXY MATERIAL PROPERTIES

MATERIAL SYSTEM	FLEXURAL TEST		TENSILE TEST				SHORT BEAM SHEAR TEST σ , KSI
			0°		90°		
			E, MSI	σ , KSI	E, MSI	σ , KSI	
HYE 1048 ALE (T 300 fiber)	18.0 (0.5)	213.0 (12.3)	21.6 (0.4)	268.0 (6.4)	1.32 (0.03)	6.6 (0.8)	12.5 (0.3)
AS/1904 (AS fiber)	17.0 (0.4)	236.0 (17.0)	19.5 (0.5)	252.0 (10.2)	3.75 (0.18)	8.4 (0.9)	14.6 (0.2)
Properties Used In Design and Analysis For Propeller Shafts	--	--	18.0	160.0	1.5	6.4	8.0

#400 MATERIALS TESTING - TARADCOM - TOWBAR

2/19/80

FIVE-1048-AIE 01-A-01 LOT 00121 Roll 1

16 PLYES 0°

COMPRESSIVE PROPERTIES TEST

SPECIMEN #	b	d	P ₁₆	S _{PSI}	* E _{MSI}		
1	.2512	.0907	2359	103,538			
2	.2495	.0913	1984	87,096	20.36		
3	.2500	.0913	2271	99,496	21.25		
4	.2504	.0915	2061	89,954	17.00		
5	.2512	.0909	2293	100,420	19.19		
MEAN				96,101	19.4	ALL FAILURES OCCURRED IN THIS AREA	
S. DEV.				7,148			
* MODULUS DETERMINED FROM STRAIN GAUGES.							

Material $E_1 = 20.36$ ksi

$E_2 = 21.25$ ksi

$E_4 = 17.00$ ksi

$E_5 = 19.19$ ksi

DIETZGEN CORPORATION
MADE IN U.S.A.

STRESS $\frac{P}{A}$
(psi)

NO. 341-ALL DIETZGEN GRAV'H PAPER
20 X 20 PER INCH

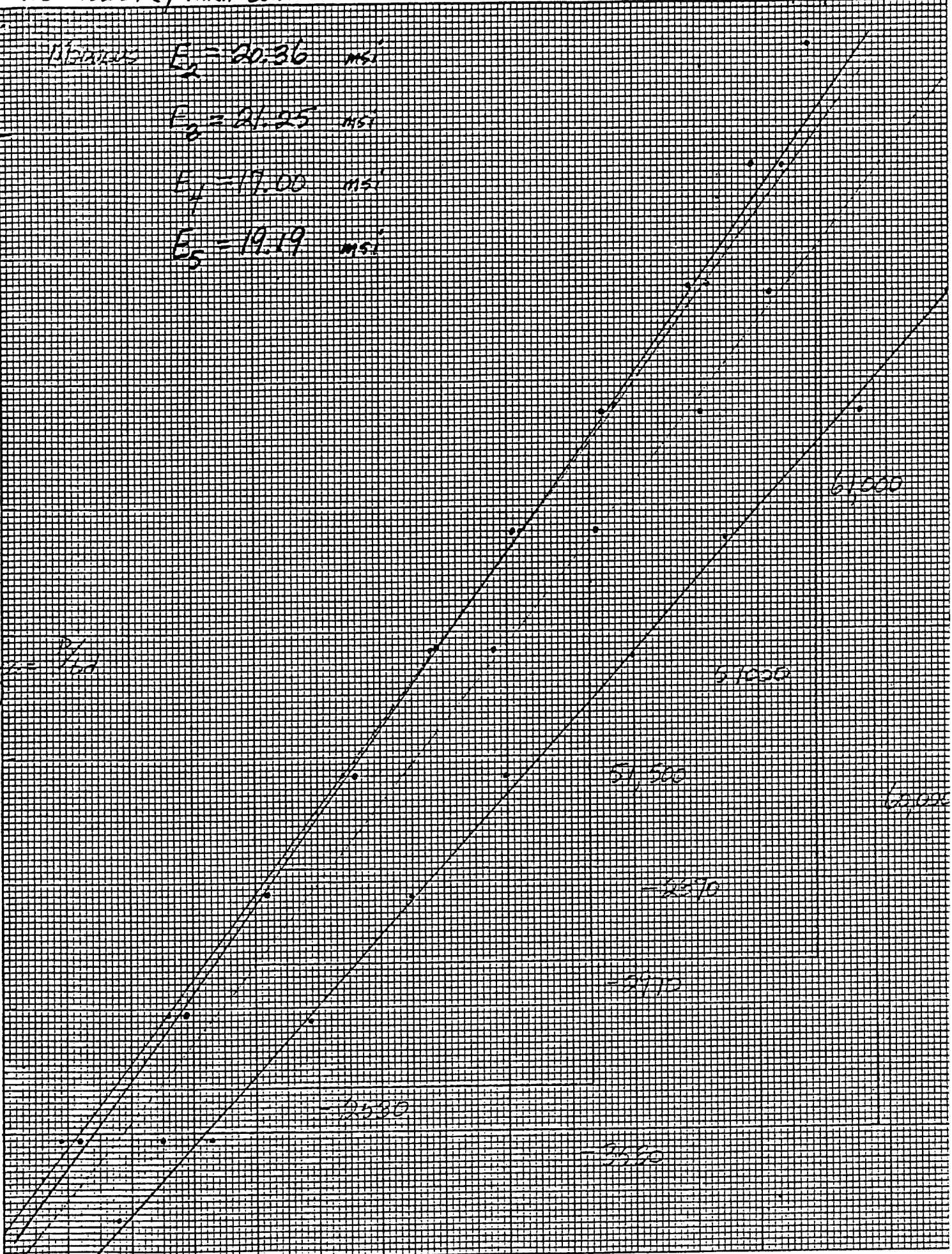

-1000 -2000 B-4 -3000 -4000

ERENDS: 1/4" STEEL, BLASTED, SANDED, SOLVENT CLEANED. 1/4" HYF-1048-A1E GRAPHITE-SANDED ONLY

ADHESIVE	TEST AREA (in ²)	S PSI	APPROXIMATE AREAS OF FAILURE				ADHESIVE	
			GRAPHITE SHEAR	COHESIVE	GRAPHITE	STEEL		
1 AF-13 T 80R MIN @ 350°F 5 PSI	0.962	3654	35%	—	55%	10%	} Not tested	
	0.992	3623	15%	—	50%	35%		
	1.016	3657	—	—	35%	65%		
	0.990	2695	—	—	10%	90%		
SOL 9628 LA-1 - 269-10 MIN @ 250° 5 PSI	0.996	1284	—	—	—	100%	} BOND LINE VERY THIN - ALL 4 not stick to steel.	
	0.969	4220	15%	—	5%	80%		
	1.011	3336	25%	—	—	75%		
	0.922	1855	—	—	5%	95%		
TLBOND 133 MIN @ 250°F 15 PSI	1.016	2517	85%	15%	—	—	} Gr cut in lab.	
	0.990	4264	10%	65%	10%	15%		
	1.006	3572	10%	80%	—	10%		
	0.998	4109	25%	65%	—	10%		
ANAMID 1-73M T B-298 CC B-2548 MIN @ 250° 5 PSI	0.977	2212	5%	25%	—	70%	} peeling off + retest.	
	0.954	3363	—	30%	—	70%		
	0.948	2815	—	30%	—	70%		
	0.944	2906	5%	15%	—	80%		

APPENDIX C

JOINT TESTS

TENSILE TEST SET #1

2/12/80

SPECIMEN	b.i.	d	L JOINT	P lbs.	AVE SHEAR	M.S.	NOTES
AF-13 ADHESIVE	1.090"	0.299"	9.0" 4.75"	8994	1005	+56%	TEST LAMINATE FAILED IN ADHESIVE (WAVINESS)
		INSIDE TAB-TO-TAB	17.80"				
1133 METALBOND	1.110"	0.298"	9.0" 4.75"	7551	830	+77%	FAILED IN LAMINATE (WAVINESS)
		INSIDE TAB-TO-TAB	17.75"				
AF-13	1.022	-	-	8708	1039	+61%	FAILED IN LAMINATE (WAVINESS)
1133	1.050	-	-	8377	972	+31%	INITIATED AT METAL TIP
CHART DRIVE =	20 mm/min.						
CROSSHEAD SPEED =	2 mm/min.						
FULL SCALE LOAD =	5000 lg.						

2/18/50

TENSILE TEST SET # 2

SPECIMEN	b	d	L JOINT	P lbs.	Avg. Shear	MS	NOTES
AF-13 ADHESIVE	1.11	0.29	9"	13,228	1453	126%	INITIATED AT METAL TAB MESSAGE ADHESIVE
2 AF-13 ADHESIVE	1.05	0.29	9"	11,640	13512	110%	GOOD JOINT FAILED LAMINATE (WAVINESS)
1133 METAL BOND	1.17	0.30	9"	11,839	1234	92%	GOOD JOINT (WAVINESS)
1133 METAL BOND	1.16	0.30	9"	11,795	1240	93%	FAILED LAMINATE (WAVINESS)
Length inside tab to tab = 11.5"							
NOTES 1) CURVATURE due to thermal stresses approx. 1/2 inch over 8.2 length of bond.							
2) Second test length shortened to within 1/2 inch of joint in effort to eliminate laminate failure due to waviness							

APPENDIX D
C-SCAN RESULTS

Figure 37

TACOM TOWBAR
SCARF JOINT C-SCAN

DATE 12-10-80

TUBE SN 3 XDCR TYPE ① .50" 2.25MHZ TRANS. ② .50" 5.0MHZ REC. MODE THRU TRANSMISSION
ENERGY 2 GAIN 40dB ATTN ~10dB GATE WIDTH 10NS GATE DELAY AS REQ'D

RESULTS - COMMENTS - (A) : NO SIGNIFICANT FLAWS INDICATED IN THE GRAPHITE/STEEL INTERFACE
ONE LARGE AND SEVERAL VERY SMALL INDICATIONS WERE FOUND IN THE KEVLAR/STEEL BOND AREA. THESE WERE RE-EXAMINED BY PULSE-ECHO A-SCAN.

RESULTS - COMMENTS - (B) : NO SIGNIFICANT FLAWS INTICATED IN THE GRAPHITE/STEEL BOND AREA. ~~AND~~ ONE LARGE AND TWO SMALLER DISCONTINUITIES EXIST IN THE KEVLAR/STEEL BOND AREA

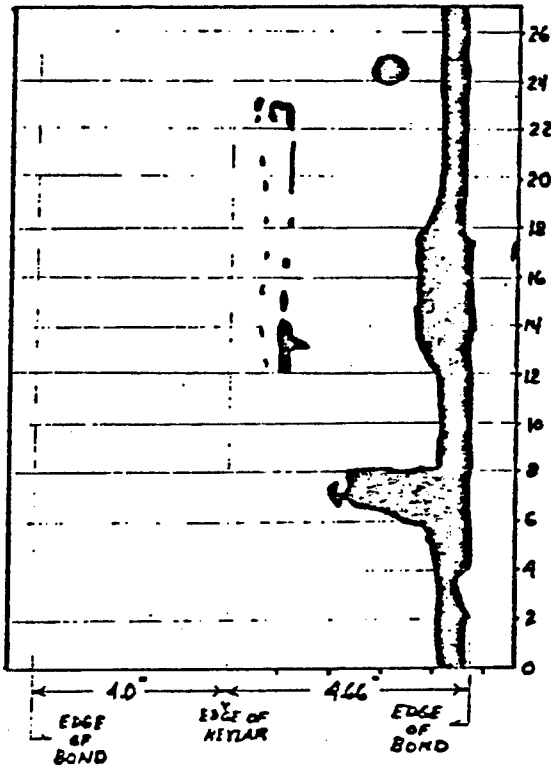

JOINT A

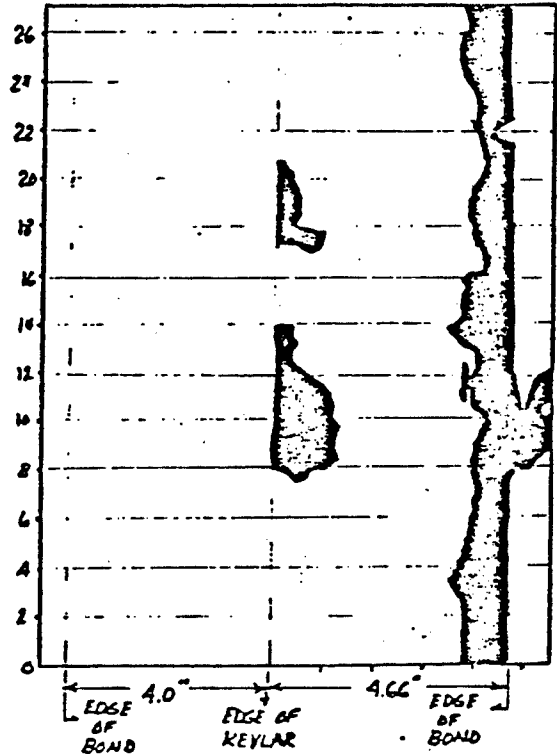

JOINT B

Figure 38

TACOM TOWBAR
SCARF JOINT C-SCAN

DATE 12-9-80

TUBE SN 5 XDCR TYPE ① .50" 2.25MHz TRANS. ② .50" 5.0MHz REC. MODE THRU TRANSMISSION
ENERGY 2 GAIN 40dB ATTN ~10dB GATE WIDTH 10NS GATE DELAY AS REQ'D

RESULTS - COMMENTS - (A) : JOINT (A) CONTAINED NO SIGNIFICANT DISCONTINUITIES IN THE GRAPHITE/STEEL INTERFACE. ALL OF THE INDICATIONS WHICH ARE SHOWN BELOW ARE IN THE KEVLAR/STEEL INTERFACE. THIS WAS VERIFIED USING PULSE-ECHO A-SCAN. THIS JOINT WAS SCANNED IN INCREMENTS RANGING FROM 1/2" TO 9/16" WITH AN INDEX INCREMENT OF .020".

RESULTS - COMMENTS - (B) : JOINT (B) CONTAINS A SIGNIFICANT DISCONTINUITIES AT THE GRAPHITE/STEEL INTERFACE. ALL OF THE INDICATIONS SHOWN BELOW ARE IN THE KEVLAR/STEEL (K/K) OR KEVLAR/GRAPHITE (K/G) INTERFACE. NO SIGNIFICANT VOID OR DELAMINATIONS IN THE GRAPHITE.

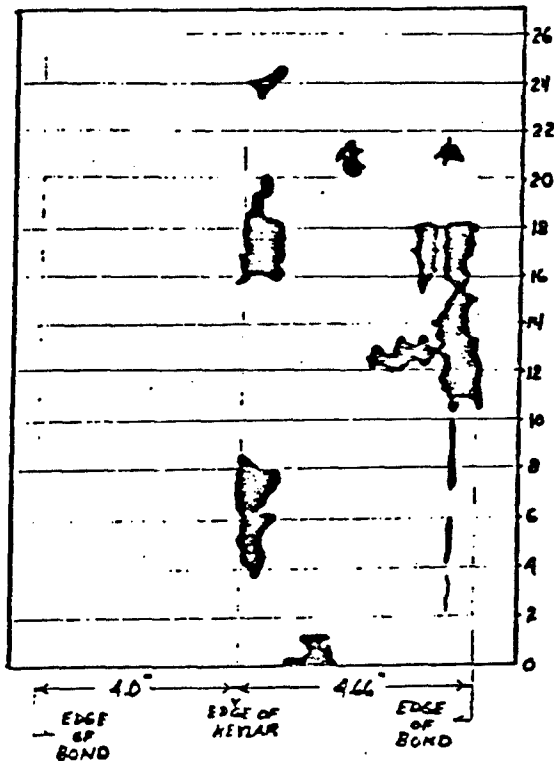

JOINT A

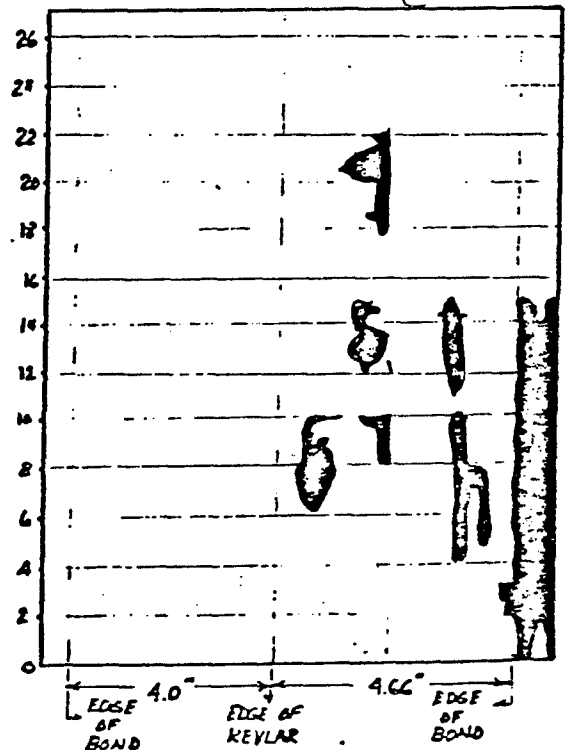

JOINT B

Figure 39
TACOM TOWBAR
SCARF JOINT C-SCAN

DATE _____

TUBE SN 6 XDCR TYPE ① .50" 2.25 MHz TRANS. ② .50" 5.0 MHz REC. MODE THRU TRANSMISSION
ENERGY 2 GAIN 40dB ATTN ~10dB GATE WIDTH 10NS GATE DELAY AS REQ'D

RESULTS - COMMENTS - (A) : NO SIGNIFICANT FLAW INDICATIONS IN THE STEEL/GRAPHITE BOND AREA. INDICATED BELOW ARE THE DISCONTINUITIES EXISTING IN THE KEVLAR/STEEL AND KEVLAR/GRAPHITE AREAS.

RESULTS - COMMENTS - (B) : NO SIGNIFICANT FLAW INDICATIONS COULD BE FOUND IN THE GRAPHITE/STEEL BOND AREA. MANY SMALL, INTERCONNECTED DISCONTINUITIES EXIST IN THE KEVLAR/STEEL BOND.

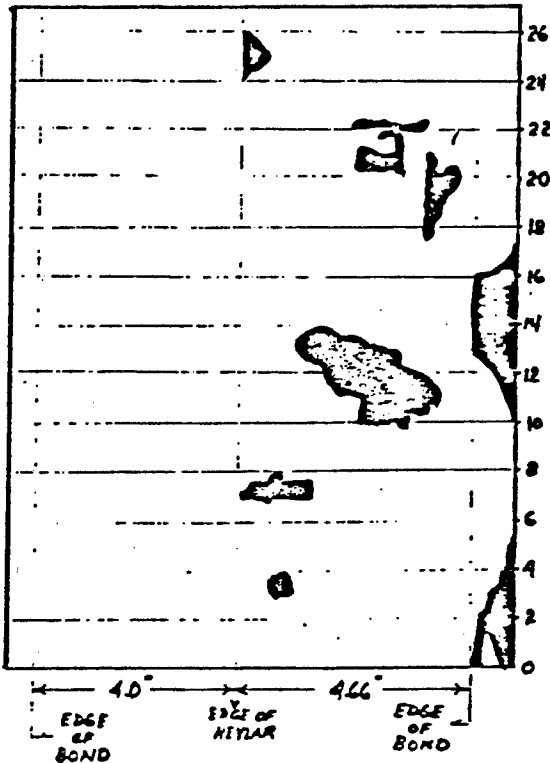

JOINT A

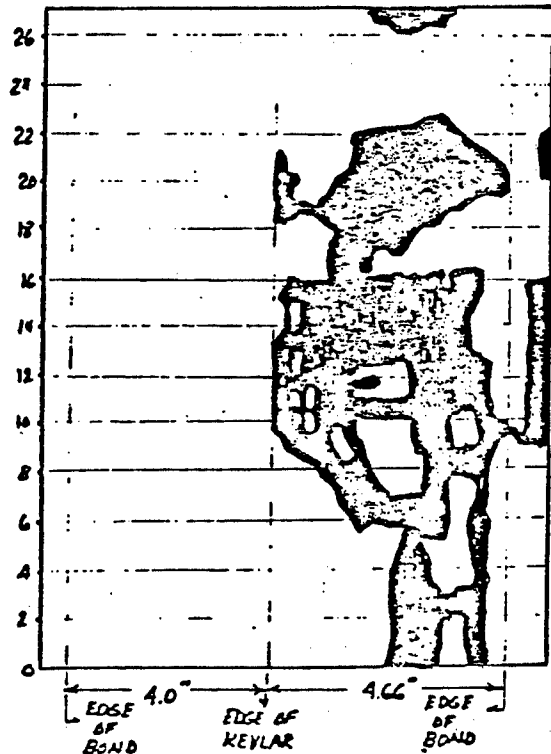

JOINT B

Figure 40

TACOM TOWBAR

SCARF JOINT C-SCAN

DATE 12-11-80

TUBE SN 7 XDCR TYPE ① .60" 2.25MHZ TRANS. ② .50" 5.0MHZ REC. MODE THRU TRANSMISSION
ENERGY 2 GAIN 40dB ATTN ~10dB GATE WIDTH 10NS GATE DELAY AS REQ'D

RESULTS - COMMENTS - (A): JOINT A HAD NO SIGNIFICANT DISCONTINUITIES IN THE GRAPHITE/STEEL BOND AREA. SEVERAL DISCONTINUITIES EXIST IN THE KEVLAR/STEEL AND KEVLAR/GRAPHITE BOND. ~~THESE~~ THESE WERE RE-EXAMINED USING PULSE-ECHO A-SCAN

RESULTS - COMMENTS - (B): JOINT B HAD NO SIGNIFICANT DISCONTINUITIES IN THE GRAPHITE/STEEL BOND AREA. INDICATED BELOW ARE THE AREAS IN WHICH THE KEVLAR/STEEL OR KEVLAR/GRAPHITE BOND WAS NOT CONTINUOUS. THESE WERE VERIFIED USING PULSE-ECHO A-SCAN.

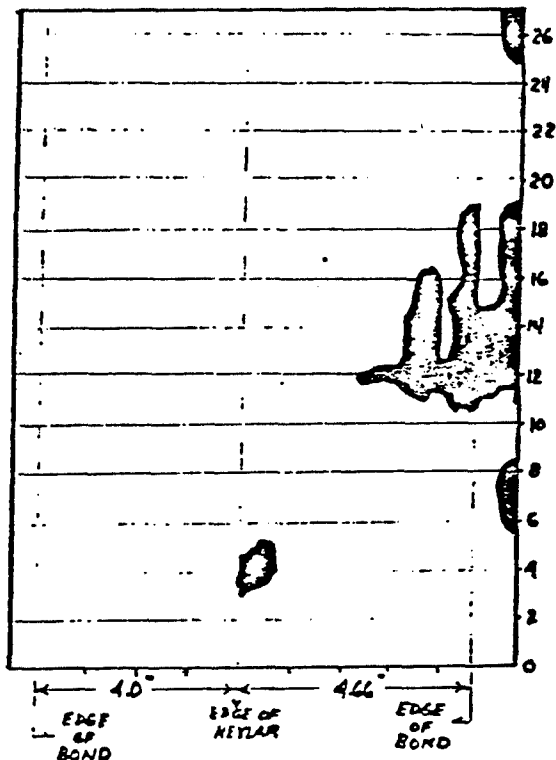

JOINT A



JOINT B

APPENDIX E

PROCESSING

Prepared By Grant Robison	Quantity 398	Lot No. 398	Dwg. No. Shaft 10003	REV.	Pt. No. 10003 E.O.	REV.	Mfg Proc No. 0121	REV. 0
Eng. Approval E.H. 7/23	QC. Approval JTW 5/23/80	Proj. Eng. Approval R. Adkinson	S/N(s) 6	TL Dwg #	REV.	Cust & Pt Descr. TARADCOM/ Tow Bar Shaft		

MATERIALS

NOTES

01-A-01 (GMS 100, Fiberite HVE 1048 A/E)	
Lot # C1-114	MFG 4/16/80
Roll # 10	
R.C. 36.6	

Oper. No.	Dept No.	OPERATION DESCRIPTION	Stamp	Date Time
01	663	This part will be made on a rubber covered mandrel. The rubber bag must be checked for leaks.		9/8/80
05	663	Use clamps to seal the ends of the rubber bag against the tool. Protect the rubber bag from being cut by the hose clamps by wrapping the rubber bag with Nylon tape or scrap rubber in the area where the hose clamps will be located.		"
10	663	Apply about 3-5 psi to the inside of the rubber bag through the air fitting on the end of the mandrel. Brush a solution of liquid soap (about 60% water, 40% soap) mixed with water over the entire surface of the rubber bag. Soap bubbles indicate air leakage. Mark any air leaks clearly with permanent ink. See Manufacturing Engineering for an Operation Process Sheet on Rubber Bag Fabrication and Repair if necessary.		"
15	663	Layout rubber bag as shown in Sketch #1. Use a ball point pen.	N/A	
20	663	Wrap rubber bag with .001" thick teflon film in the 68.02" area between Mark 1 and Mark 4 (Sketch #1). Double backed tape should be used to secure film. The wrap must be 1 1/2 turns, not butt jointed.		
25	663	Cut patterns per Sketch #2.		
30	663	Lay-up per stacking sequence in Sketch #2. Trim each pattern to wrap around the lay-up making a butt joint. No overlaps are permitted on butt joints, with the exception of the first pattern. Sometimes a slight overlap is required to get the first pattern to stay in place. A heat compaction is called out on Sketch #2 at plies 17 and 36. To heat compact, use the Tedlar winder to compact the part with nylon tape. Put the mandrel in oven for 20 minutes at 150°F. Remove part from oven, remove nylon tape being careful not to disturb laminate, and rewrap with nylon tape to further compact. Each pattern must be centered in relation to the first ply on the mandrel within .050". Seams on ±45° patterns are to be staggered 90°.		"

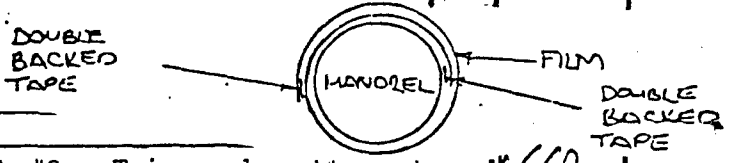

per No	Dept No.	OPERATION DESCRIPTION	Stamp	Date
35	663	Sand inside of kevlar sleeve until visibly rough. Clean with acetone. Use 80 grit aluminum oxide sandpaper.		
40	663	Check fit of end fittings on lay up. They should slide on far enough to achieve a total length of $69.48 \pm .02$ " end to end. 69.52 OK GJR		
45	663	Sandblast inside of two steel end fittings. Clean entire end fitting with trichloroethylene. Handle parts with clean gloves only after cleaning. Apply metlbond 1133 (03-A-01) and AF-13 to sleeve per sketch below. See Manufacturing Engineering for AF-13. Leave protective films in place on adhesive. It may be necessary to warm end fittings to get the AF-13 to stick.		7/1/78

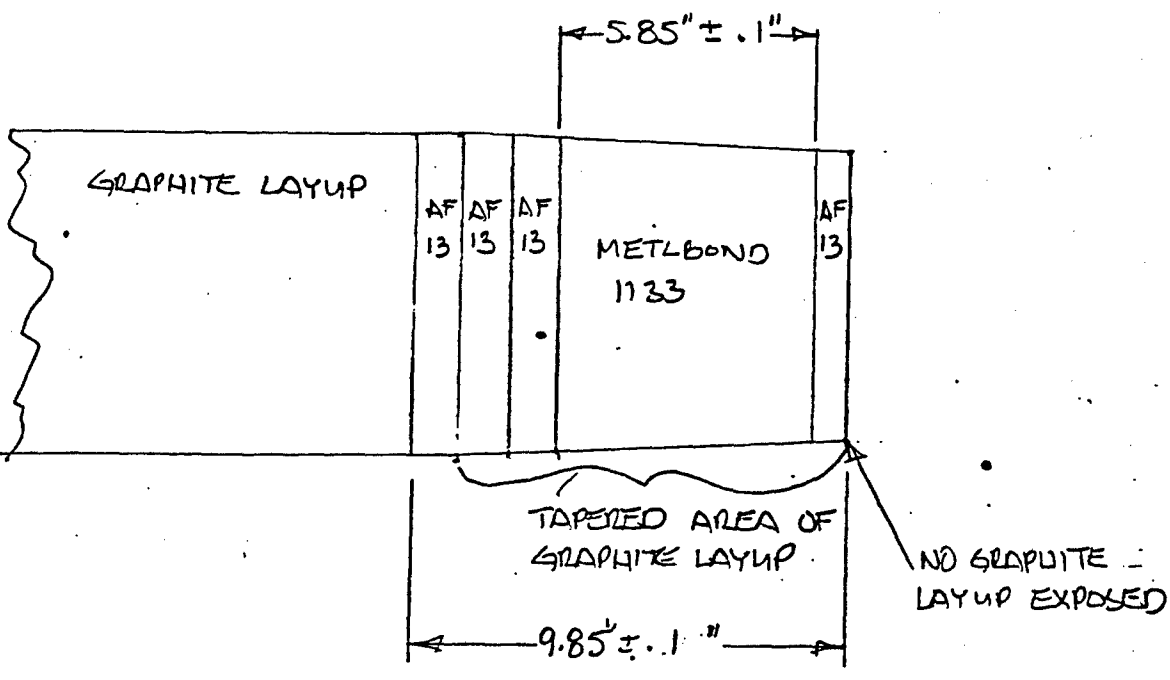

50	663	Check fit of sleeves on lay up. They should slide on far enough to achieve a total length of $69.48 \pm .02$ " end to end.		
55	663	(NEON) SLEEVES THOROUGHLY WITH ACETONE Assemble sleeves into kevlar cover. Measure total length. Total length should be $69.48 \pm .02$ " end to end. Mark the actual total length on the rubber bag centered with respect to the lay up so that the cover with sleeves attached can be located properly over the lay up. MARK LOCATION OF KEVLAR COVER END ON EACH SLEEVE		
60	663	E-3 Mix a small amount of Ren Fast-Weld No. 10. Spread a thin coat in a 1" wide band on the in-board side of the mark made in Operati... Immediately insert sleeve fully into kevlar cover. Clean off any excess. Hold together tightly for 5 minutes \pm 1 minute. This operation must be performed rapidly as Fast-Weld No. 10 has a pot life of only 4 minutes. The purpose of this operation is to prevent the sleeve from shifting during subsequent operations and seal the joint in use.		

MANUFACTURING PROCESS SHEET
GRAFTEK/ EXXON ENTERPRISES

Oper. No.	Dept No.	OPERATION DESCRIPTION	Stamp	Date
65	663	Remove the protective covering from the adhesive on both sleeves. Slide the kevlar cover with one sleeve attached into position over the lay up.. Check fit of second sleeve.	<i>[Signature]</i>	9/12/68
70	663	Repeat Operation 60 and bond second sleeve into kevlar cover.	<i>[Signature]</i>	"
75	663	Insert a thermocouple wire under each sleeve. Wrap mylar tape around wire end to prevent the wire from puncturing the rubber bag. DO NOT GET THE WIRE BETWEEN THE GRAPHITE AND THE SLEEVE.	<i>[Signature]</i>	"
80	663	Shim the sleeves using nylon tape, rubber, etc. so that they are concentric with the lay up.	<i>[Signature]</i>	"
85	663	Wrap mandrel, rubber bag and kevlar cover with nylon tape. Firm tension should be used, but not so tight as to distort kevlar cover. Be sure to let thermocouple wires stick out. Use 1/2" overlap.	<i>[Signature]</i>	"
90	663	Apply hose clamps at each end of rubber bag, OVER NYLON WRAP.	<i>[Signature]</i>	"
95	663	Wrap a second layer of nylon tape over everything. LEAVE HOLE CLAMP SLEEVES EXPOSED.		
100	663	Put in oven and apply .85 psi \pm 5 psi. Listen for air leaks. DO NOT SET ON OVEN FLOOR AS HEAT UP RATE IS TOO SLOW ON FLOOR.	<i>[Signature]</i>	9/15/68
105	663	If no leaks are present, hook up temperature recorder and raise part temperature to 250 ²⁶⁵ $\text{OF} \pm 5\text{OF}$. Hold at this temperature for a minimum of $\frac{2}{3}$ hours.	<i>[Signature]</i>	"
110	663	Cool under pressure to below 175 OF .	<i>[Signature]</i>	"
115	663	Remove processing materials. Remove part from mandrel. Wrap mandrel with a protective layer of nylon tape and store.		
120	663	Submit part, Operation Process Sheets and Cure Chart to inspection.		
125	668	Inspect per print.		

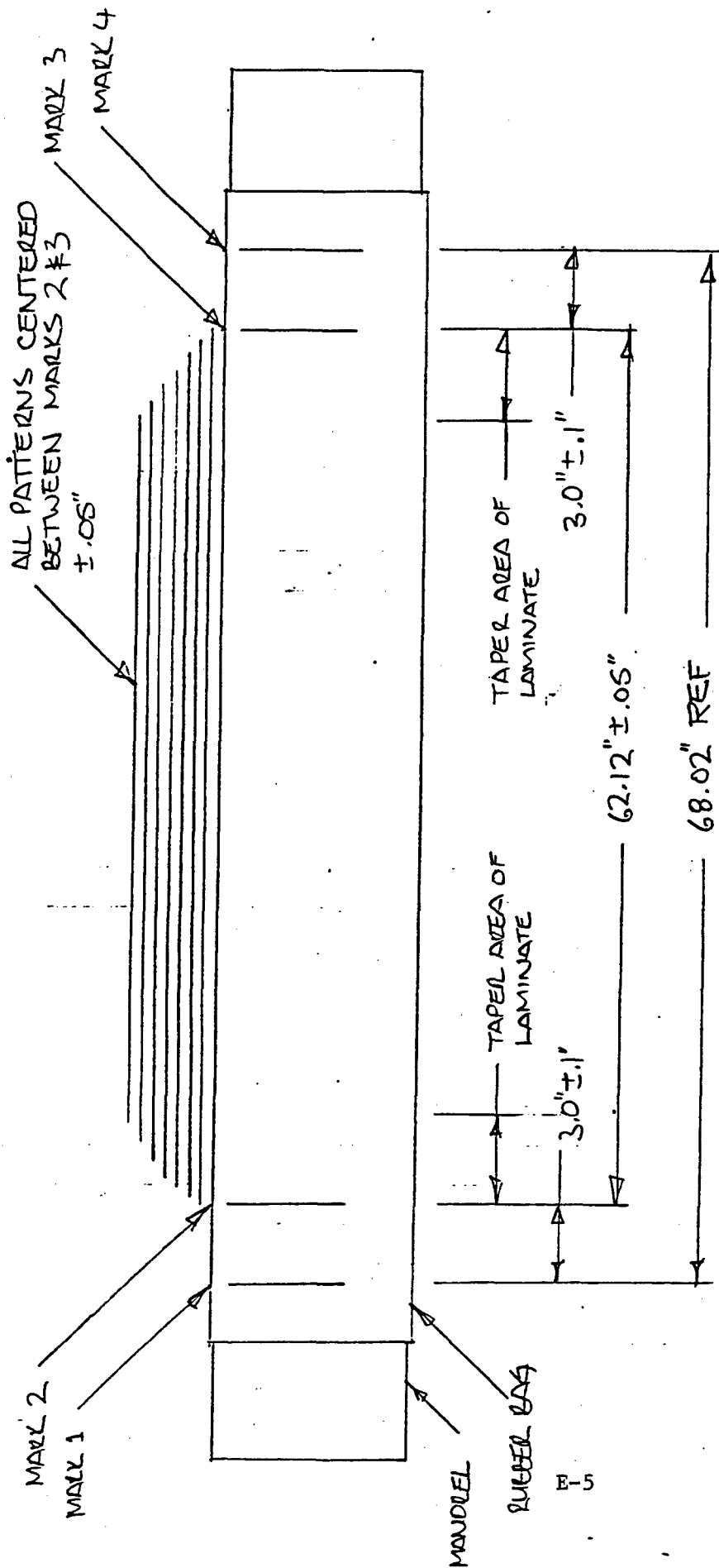

SKETCH #1

ATCH #2

MATERIAL: 01-A-01 (GMS 100, FIBERITE HYE 1048 A1E)

PATTERN No.	PLY NO.	ORIENT-ATION	WIDTH OF PATTERN	ROUGH LENGTH OF PATTERN (CIRCUMFERENCE)	COMPACT
#19 2 PLY PATTERN, 2 PLYS ON TOOL	PLY 36	+45	44.72" ± .05"	14"	HEAT COMPACT
	PLY 35	-45			
#18 2 PLY PATTERN, 2 PLYS ON TOOL	PLY 34	+45	44.92" ± .05"	14"	
	PLY 33	-45			
#17 1 PLY ON TOOL	PLY 32	0	45.72" ± .05"	14"	
#16 2 PLY PATTERN, 2 PLYS ON TOOL	PLY 31	0	46.72" ± .05"	14"	
	PLY 30	0			
#15 2 PLY PATTERN, 2 PLYS ON TOOL	PLY 29	0	47.72" ± .05"	13 1/2"	
	PLY 28	0			
#14 2 PLY PATTERN, 2 PLYS ON TOOL	PLY 27	0	48.92" ± .05"	13 1/2"	COMPACT
	PLY 26	0			
#13 2 PLY PATTERN, 2 PLYS ON TOOL	PLY 25	0	49.92 ± .05"	13 1/2"	
	PLY 24	0			
#12 2 PLY PATTERN, 2 PLYS ON TOOL	PLY 23	0	50.92 ± .05"	13 1/2"	
	PLY 22	0			
#11 2 PLY PATTERN, 2 PLYS ON TOOL	PLY 21	0	51.92 ± .05"	13 1/2"	
	PLY 20	0			
#10 2 PLY PATTERN, 2 PLYS ON TOOL	PLY 19	0	53.12" ± .05"	13"	
	PLY 18	0			
#9 2 PLY PATTERN, 2 PLYS ON TOOL	PLY 17	0	54.12" ± .05"	13"	HEAT COMPACT
	PLY 16	0			
#8 2 PLY PATTERN, 2 PLYS ON TOOL	PLY 15	0	55.72" ± .05"	13"	
	PLY 14	0			
#7 2 PLY PATTERN, 2 PLYS ON TOOL	PLY 13	0	57.32" ± .05"	13"	
	PLY 12	0			
#6 2 PLY PATTERN, 2 PLYS ON TOOL	PLY 11	0	58.92" ± .05"	13"	
	PLY 10	0			
#5 2 PLY PATTERN, 2 PLYS ON TOOL	PLY 9	0	60.52" ± .05"	12 1/2"	COMPACT
	PLY 8	0			
#4 1 PLY, 1 PLY ON TOOL	PLY 7	0	62.12" ± .05"	12 1/2"	
#3 2 PLY PATTERN, 2 PLYS ON TOOL	PLY 6	0	62.12" ± .05"	12 1/2"	
	PLY 5	0			
#2 2 PLY PATTERN, 2 PLYS ON TOOL	PLY 4	-45	62.12" ± .05"	12 1/2"	
	PLY 3	+45			
#1 2 PLY PATTERN, 2 PLYS ON TOOL	PLY 2	-45	62.12" ± .05"	12 1/2"	
	PLY 1	+45			

24 - ± 150
28 - 0

|||||

|||||

|||||

Cut + Layup
16 + 19.

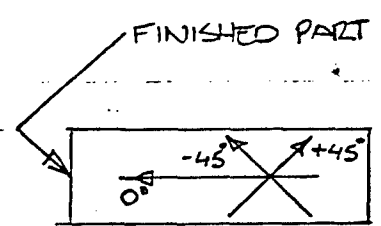

Prepared By Grant Robison	Quantity 375 001	Dwg. No. Cover 10003	REV.	Pt. No. 10003 E.O.	Mfg Proc No. 0114 REV. 0
Eng. Approval 8/5/80	QC. Approval 5/14/80	Proj. Eng. Approval 5/16/80	S/N(s) 8	TL Dwg # T-SK-10003 REV.	Cust & TARADCOM/ Pt Descr. tow bar tube cove KSL# NO. 1

MATERIALS

NOTES

FIBERITE MXM 7701/281	1. READ ENTIRE PROCESS BEFORE STARTING.
	2. Record Mat'l Lot No. --- Roll No. -
	3. Roll weight before cutting.
	4. Roll weight after cutting.

Oper. No.	Dept No.	OPERATION DESCRIPTION	Stamp	Date Time
01	653/663	Entirely disassemble mandrel and clean thoroughly with acetone, reassemble.	<i>[Signature]</i>	20 Nov
05	653/663	Wipe two coats of DC-20 Mold Release(69-A-03). Cure coating for two hours in a 375°F oven.	<i>[Signature]</i>	"
10	653/663	Apply one coat of RAM 225 to mandrel. Air dry 10 minutes. Buff lightly. Apply second coat of RAM 225. Air dry 10 minutes. buff lightly.	<i>[Signature]</i>	"
15	653/663	Cut patterns per sketch #1.	<i>[Signature]</i>	"
20	653/663	Apply 3" wide build-up patterns per sketch #2. Trim ends to form butt joints. Apply 1.5" wide build-up patterns per sketch #2 with seams 180° from previous ply. Trim ends to form butt joints.	<i>[Signature]</i>	"
25	653/663	CENTER MANDREL ON PATTERN. MARK STARTING POINT OF WRAP ON MANDREL. ROLL LARGE PART OF OVERALL PATTERN ON MANDREL PER SKETCH WITH LEAD 90° FROM PREVIOUS PLY, BUTT EDGE OF SMALL PART OF OVERALL PATTERN TO EDGE OF PATTERN ON MANDREL. ROLL PATTERN ON MANDREL. AFTER ROLLING TRIM PATTERN EDGE PARALLEL TO MANDREL CENTER-LINE TRIMMED EDGE MUST MATCH STARTING MARK.	<i>[Signature]</i>	"
30	653/663	Compact lay-up with nylon tape. Put mandrel in oven for 20 minutes ± 5 minutes at 150°F ± 10°F. Remove from oven and remove nylon tape.	<i>[Signature]</i>	"
		USE 1/4" LEAD		
35	653/663	Compact lay-up with nylon tape. Insert thermocouple wire under tape at each end of part. Attach thermocouple wires to temperature recorder. Record the following information on temperature chart. Part number, serial number, date and time of cure, chart speed, job number and operator initials. Cure for 120 minutes ± 15 minutes at 260°F ± 10°F.	<i>[Signature]</i>	"
40	653/663	Pull mandrel from part. Route part and operation process sheet to Machine Shop for trim. Part must be kept free of oil and grease.	<i>[Signature]</i>	"
45	662	Trim part per sketch #3. Route part and operation process sheet to lab.	<i>[Signature]</i>	"

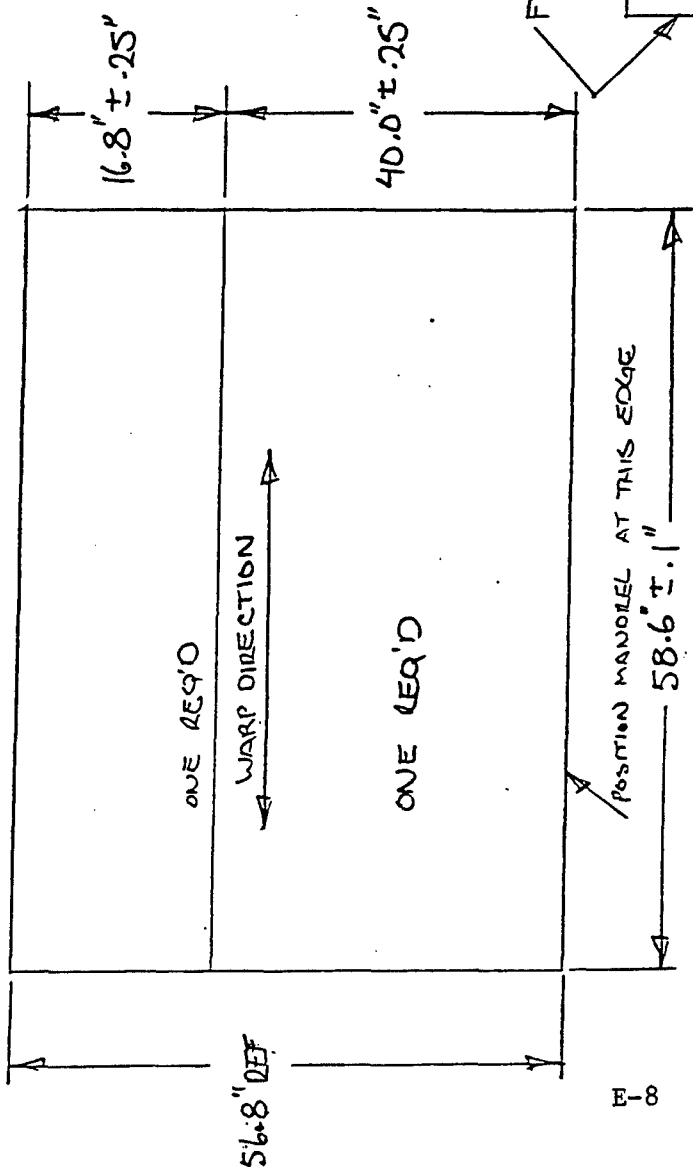

NOTES:

1. FOIL TAYADCOM PART 10003. THIS PATTERN FORMS THE COVER.
2. MATERIAL IS FIBERITE MXM 7701/281, 50" WIDE
3. USE MANOMEL NO. T-SK10003
4. WARP DIRECTION TO BE AS SHOWN ± 5° 00'
5. WRAPPED PART WILL BE 4 PUES.

(ON THESE TWO SMALL PATTERNS WARP DIRECTION DOES NOT MATTER)

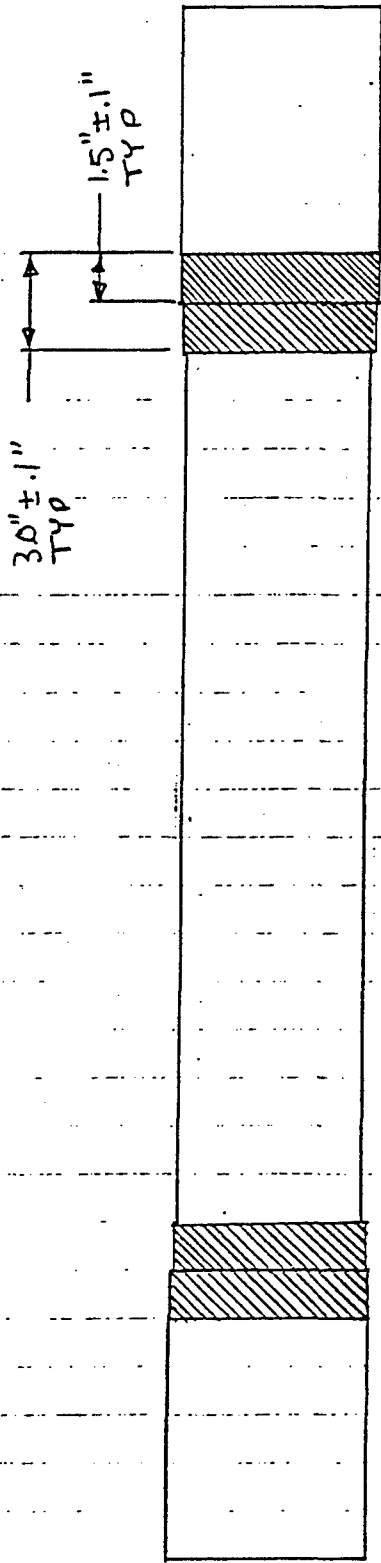

NO GAP BETWEEN PILES AND
THE MANHOLE SHOULDER
NO PILES MAY OVERLAP
SHOULDER

BUILD UP DETAIL

SKETCH #2

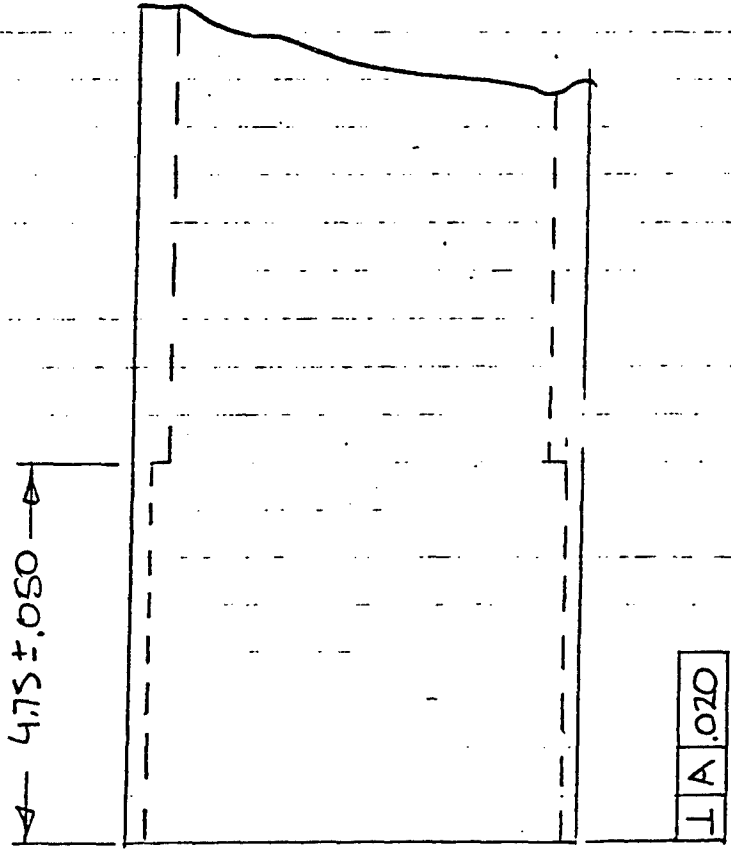
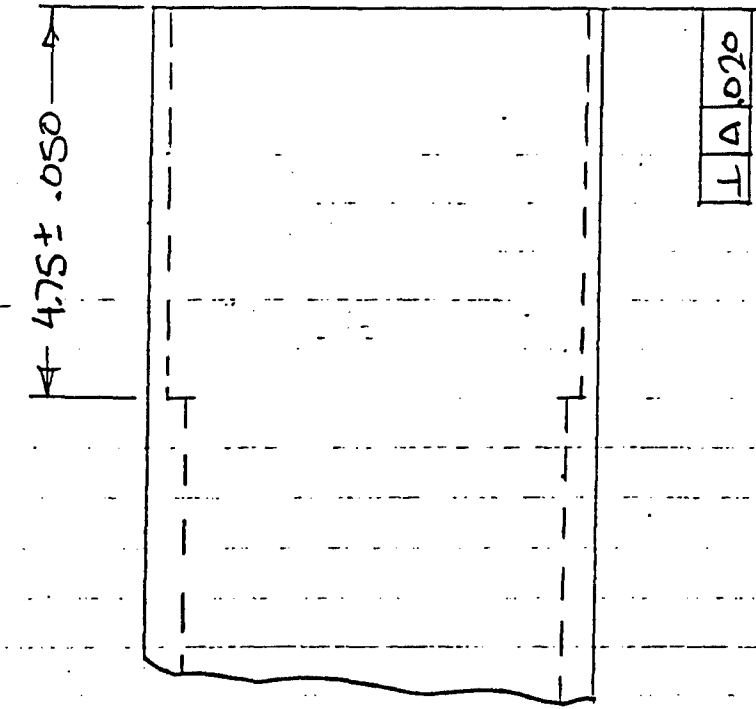

A

TRIM DIMENSIONS
SKETCH #3

DISTRIBUTION LIST

	<u>COPIES</u>
Administrator Defense Technical Information Center ATTN: DTIC-DDA-1 Cameron Station - Bldg 5 Alexandria, VA 22314	12
Commander US Army Tank-Automotive Command ATTN: DRSTA-TSL Warren, MI 48090	2
Commander US Army Tank-Automotive Command ATTN: DRSTA-NF Warren, MI 48090	1
Commander US Army Armament Materiel Readiness Command ATTN: DRSAR-LEE-D/Mr. Cahill Rock Island, IL 61299	1
Director US Army Materials and Mechanics Research Center ATTN: DRXMR-M Watertown, MA 02172	1
Ciba-Geigy Riggs Engineering Dept 8245A Ronson Road San Diego, CA 92111	1