

MICROCOPY RESOLUTION TEST CHART  
NATIONAL BUREAU OF STANDARDS 1963-A

UNCLASSIFIED

SECURITY CLASSIFICATION OF THIS PAGE (When Data Entered)

2

REPORT DOCUMENTATION PAGE		READ INSTRUCTIONS BEFORE COMPLETING FORM
1. REPORT NUMBER	2. GOVT ACCESSION NO.	3. RECIPIENT'S CATALOG NUMBER
Technical Report #4, 6170-698:WB:vl	Ab-4130 611	
4. TITLE (and Subtitle) Phthalocyanine Derivatives Specifically Designed for Fabrication of Organic Semiconductor Gas Sensors		5. TYPE OF REPORT & PERIOD COVERED Interim Technical Report 1 Mar 83 - 1 July 83
		6. PERFORMING ORG. REPORT NUMBER Technical Report #4
7. AUTHOR(s) W.R. Barger, A.W. Snow, H. Wohltjen, J. Lint and N.L. Jarvis		8. CONTRACT OR GRANT NUMBER(s) WR 30013 1 Oct 82
9. PERFORMING ORGANIZATION NAME AND ADDRESS Naval Research Laboratory Washington, DC 20375		10. PROGRAM ELEMENT, PROJECT, TASK AREA & WORK UNIT NUMBERS 61153N RR013-01-OK NR 633-841
11. CONTROLLING OFFICE NAME AND ADDRESS Office of Naval Research, Code 413 800 N. Quincy St. Arlington, VA 22217		12. REPORT DATE 12 July 1983
		13. NUMBER OF PAGES
14. MONITORING AGENCY NAME & ADDRESS (if different from Controlling Office)		15. SECURITY CLASS. (of this report) Unclassified
		15a. DECLASSIFICATION/DOWNGRADING SCHEDULE
16. DISTRIBUTION STATEMENT (of this Report) Approved for public release; distribution unlimited.		
17. DISTRIBUTION STATEMENT (of the abstract entered in Block 20, if different from Report)		
18. SUPPLEMENTARY NOTES Prepared for publication in the ACS Monograph "Microsensors for Chemical Detection".		
19. KEY WORDS (Continue on reverse side if necessary and identify by block number) Phthalocyanine; semiconductor; microsensor; monolayer		
20. ABSTRACT (Continue on reverse side if necessary and identify by block number) This paper describes studies in which metal-free and metal substituted phthalocyanine films were sublimed onto the surfaces of interdigital electrodes in order to measure the change in the conductivity when the coated electrodes were exposed to a series of test gases. Also reported are data on tetra- cumylphenoxy and tetraoctadecyl ether derivatives of the metal-free and metal substituted phthalocyanines which were synthesized specifically for use as coating materials to be applied one monolayer at a time by the Langmuir- Blodgett (LB) method.		

ADA 130011

DTIC FILE COPY

DTIC ELECTE  
JUL 22 1983  
S E

DD FORM 1473 1 JAN 73 EDITION OF NOV 65 IS OBSOLETE  
S N 0102-LF-014-6601

UNCLASSIFIED

SECURITY CLASSIFICATION OF THIS PAGE (When Data Entered)

83 07 22 041

Phthalocyanine Derivatives Specifically Designed  
for Fabrication of Organic Semiconductor Gas Sensors

W.R. Barger, H. Wohltjen, A. Snow, J. Lint, and N.L. Jarvis  
Chemistry Division, Surface Chemistry Branch  
Naval Research Laboratory  
Washington, DC 20375

When sulfur dioxide, benzene, air, ethanol, water, dimethyl methylphosphonate, and ammonia vapors were introduced into a stream of helium flowing over thin layers of phthalocyanines that were sublimed onto the surface of interdigital electrodes, the conductivities of the coatings increased or decreased depending on the type of phthalocyanine and on the vapor. A series of tetracumylphenoxy- and tetraoctadecyl ether phthalocyanines were synthesized specifically for use as monomolecular films to be deposited by the Langmuir-Blodgett technique as vapor-sensing coatings on electrode surfaces. These materials appeared to form dimer structures in the monolayers. From the I-V curve for a microelectrode coated with a mixed multilayer film of platinum cumylphenoxy phthalocyanine and octadecanol, a surface resistivity of  $2.8 \times 10^{14}$  ohms/square was determined.



Accession For	
NTIS GRA&I	<input checked="" type="checkbox"/>
DTIC TAB	<input type="checkbox"/>
Unannounced	<input type="checkbox"/>
Justification	
By _____	
Distribution/	
Availability Codes	
Dist	Avail and/or Special
<b>A</b>	

A program of research directed at the eventual development of small, low cost gas sensors that take advantage of modern microfabrication technology and advances in microcomputing capabilities is presently underway at our laboratory. Specifically, we are placing thin, chemically-selective coating films on the surfaces of micro interdigital electrodes and surface acoustic wave (SAW) devices (1). Figure 1 illustrates the size and typical design of such devices. A significant part of the effort is directed at fundamental studies of the materials to be used as coating films for the microsensors and at techniques to deposit these films on sensor surfaces. There are numerous coating techniques that might be used, such as deposition from a volatile solvent, polymerization after contact with the surface, spin coating, sublimation, dipping, or deposition of one monomolecular layer at a time by the Langmuir-Blodgett technique.

This paper describes studies in which metal-free and metal substituted phthalocyanine films were sublimed onto the surfaces of interdigital electrodes in order to measure the change in the conductivity when the coated electrodes were exposed to a series of test gases. Also reported are data on tetracumylphenoxy and tetraoctadecyl ether derivatives of the metal-free and metal-substituted phthalocyanines which were synthesized specifically for use as coating materials to be applied one monolayer at a time by the Langmuir-Blodgett (LB) method (2). Only the

physical data describing the behavior of monomolecular films of these substances on water surfaces is tabulated here along with a preliminary example of the electrical characteristics of a multilayer film, i.e., a current vs. voltage diagram. Future work will include exposures of test gases to electrodes coated with ordered multilayer films deposited by the LB technique.

Phthalocyanines were chosen for these experiments because they exhibit the desired electrical behavior and because they are quite stable materials—an important consideration in fabricating any practical gas-detecting device. A considerable body of literature exists describing the physical and chemical properties of the phthalocyanines. A review of the work prior to 1965 is contained in the chapter by A.B.P. Lever in volume 7 of *Advances in Inorganic Chemistry and Radiochemistry* (3). Electrical properties of phthalocyanines have been receiving increased attention in recent years. The photoconductivity of metal-free phthalocyanine has been studied in detail (4,5). Electrical properties of lead phthalocyanine have been studied extensively, especially by Japanese workers (6,7,8,9). They have also studied the alteration of the conductivity of this material upon exposure to oxygen (10,11). The effects of a series of adsorbed gases ( $O_2$ ,  $H_2$ , CO, and NO) on the conductivity of iron phthalocyanine have been recently reported (12). A study of general electrical properties of metal phthalocyanines of the first

transition period with some assessments of the effects of oxygen has been prepared by Beales et al. (13). The use of thin Cu, Ni, and metal-free phthalocyanine films as the sensing material in a gas sensor has been described by Sadoaka et al. (14). These workers studied the effect of NO<sub>2</sub>, NO, SO<sub>2</sub>, O<sub>2</sub>, N<sub>2</sub> and CO on the electrical conductivity of the phthalocyanine films. A quantitative study of the effects of a series of gases adsorbed on the surface of single crystals of Mn, Co, Ni, Cu, Zn, Pb, and metal-free phthalocyanines and of other semiconducting materials has been done by van Ewyk et al. (15). Gases studied included NO<sub>2</sub> + NO, O<sub>2</sub>, BF<sub>3</sub> NH<sub>3</sub>, ethylene, CO, and other organic vapors.

Baker et al. (16) have recently reported the successful preparation of Langmuir-Blodgett films from metal-free phthalocyanine and from tetra-tert-butyl phthalocyanine.

#### Experimental.

Chemicals. The phthalocyanine compounds used to prepare sublimed films were prepared, purified, and characterized in our laboratory. A series of new phthalocyanine derivatives, soluble in organic solvents, were synthesized especially for use as coating films to be applied to sensors by the LB technique. The tetracumylphenoxy derivatives of the phthalocyanines were prepared by a nitro-displacement reaction of cumylphenol and 4-

nitrophthalonitrile followed by heating the cumylphenoxy phthalonitrile in the presence of finely dispersed metals or chloride salts:

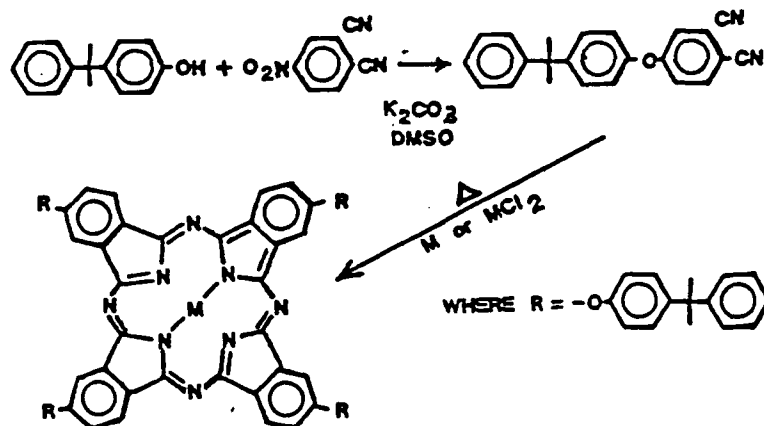

Metal-free tetracumylphenoxy phthalocyanine was prepared from the phthalonitrile heated in the presence of a nucleophilic reducing agent such as hydroquinone. The tetra-octadecyl ether derivatives were prepared in an analogous series of reactions.

Measurement System. For the studies involving the exposure of coating films to various gases, the phthalocyanines were sublimed onto the surface of the electrodes which were microfabricated on a SAW device (Fig. 1). The coated interdigital electrodes on the ends of the SAW device were used as chemi-resistors, not for the generation and measurement of surface acoustic wave signals. A direct current was passed from one half of the interdigital electrode through the coating film to the other half of the

interdigital electrode. The coated quartz substrate with an interdigital electrode at each end was housed in a rectangular, all stainless steel chamber with an entrance and an exit for a flowing gas stream. Only one of the coated interdigital electrodes was used for the measurement of conductivity changes in the presence of a test gas. The detector block for the SAW device has been previously described (1).

In the case of the microelectrode (Fig. 1) used for the I-V curve of a multilayer film deposited by the LB technique, a special low volume cell was fabricated and is shown in Figure 2. The cylindrical plug that surrounds the electrode on all sides but the top is made of teflon. The remainder of the block is fabricated from polyvinyl chloride except for the stainless steel tubing and the gold-plated electrodes.

Electrical measurements with both types of cells were made by using the coated and the reference electrodes as the resistors in an inverting operational amplifier circuit. The ratio of the resistance of the reference electrode ( $R_2$ ) to the resistance of the measuring electrode controlled the measured voltage E out:

$$E \text{ out} = - (R_2/R_1) E \text{ in} \quad (1)$$

The E out voltage was passed to an A/D converter and recorded by a microcomputer. The apparatus was arranged as shown in Figure 3. A helium carrier gas flowing at 100 cc/min passed over the

reference electrode, into a 500 cc dilution flask, and then over the sample-coated electrode. The gas stream then passed through a six-port valve to waste. By periodically switching the valve with an automatic actuator, 5 cc samples of the gas mixture that had just passed over the measuring electrode could be injected into a gas chromatograph in order to monitor the change in concentration with time due to dilution. From this data the equation describing the dilution could be determined, and the concentration as a function of time could be extrapolated to values below the detection limit of the thermal conductivity detector. The percent of initial concentration vs. time in this arrangement of experimental apparatus is shown in Figure 4. A sufficient amount of test material was injected into the dilution flask to produce an initial concentration of either 100 or 1000 ppm by volume in the vapor phase. The more reactive vapors were introduced into the apparatus at the lower concentration.

Monomolecular Film Characterization System. Monolayer films of the derivatives of the phthalocyanines were characterized in the classical manner using a Langmuir trough. Our present version of this apparatus has been slightly modified from a system described in an earlier publication (17). The trough in the present system consists of a solid glass block etched on the top surface to a depth of 2 mm to create a shallow basin for holding water that is 73 cm by 12 cm. To allow dipping of devices to be coated

with film a 3 cm diameter hole was bored to a depth of 3 cm near one end of the block.

For a run, triply distilled water was added to the trough and allowed to stand for about 5 minutes. The surface was then further cleaned by sweeping with a series of paraffin-coated bars to remove any last traces of surface-active material. A paraffin-coated bar for the compression of the film was placed against the screw-driven guides, and then the solution of the film-forming material in a volatile organic solvent was added slowly to the surface with a precision microsyringe. For all data reported here the solvent was benzene, concentrations were as close as possible to 1 mg/ml, and the volume of the solution added to the surface was 0.150 ml. After a 5-minute period to allow the solvent to evaporate thoroughly from the monolayer, surface tension was recorded while the film was slowly compressed with the moving bar.

Surface tension was measured by the Wilhelmy Plate technique using a 1 cm<sup>2</sup> platinum plate suspended from a strain gauge configured as a microbalance. Output from the strain gauge passed to a strip chart recorder to produce the film pressure vs. area isotherm. For dipping electrodes through the film a motorized rack and pinion was used. The reversible motor was controlled by a Carle Valve minder, and an electronic device with

a variable-speed rotary switch actuator which allowed precise control of the stopping times and direction switching times of the rack and pinion. Because the electrodes to be coated were attached to the rack and pinion by a long, thin, highly flexible wire thread with a relatively heavy clip at the electrode end, vibrations transmitted from the motor were avoided.

### Results and Discussion

Sublimed Films Exposed to Vapors. The six different types of phthalocyanine films that were sublimed onto the interdigital electrodes at the ends of SAW devices were exposed to each of a series of seven vapors. Two SAW devices, one for reference and one for measurement, were coated by sublimation simultaneously. Metal-free, Co, Cu, Fe, Pb, and Ni phthalocyanines were applied to the interdigital electrodes of the SAW devices in this manner. Vapors studied were ammonia, dimethyl methylphosphonate, water, air, benzene, and sulfur dioxide. The relative change in conductivity was computed from the measured voltage by the microcomputer-controlled apparatus:

$$(\sigma - \sigma_0)/\sigma_0 = (V - V_0)/V_0 \quad (2)$$

where the subscript zero variables are the initially measured values prior to vapor exposure, and the variables without subscripts are measured values during the exposure to a test vapor. Figure 4 presents the conductivity change data for the

first 25 minutes of exposure to the test vapors which were decreasing exponentially in concentration with time.

The maximum percent change in relative conductivity of each phthalocyanine is listed for each vapor in Table I.

Table I. Maximum Percent Change in Relative Conductivity for Sublimed Phthalocyanine Films Exposed to Vapors

Vapor	Conc. (ppm)	Phthalocyanine Type					
		Co	Cu	Fe	Pb	Ni	H <sub>2</sub>
Sulfur Dioxide	100	-9	+3	+28	-8	+11	+10
Benzene	1000	-2	-2	- 2	+4	+ 6	(+11)
Air	1000	-5	0	- 4	-8	+ 2	(+25)
Ethanol	1000	-5	-15	-11	-4	- 1	(+18)
Water	1000	-5	-15	-11	-6	- 5	(+21)
DMMP	100	-7	-21	-10	-51	- 5	+23
Ammonia	100	-72	-81	-36	-24	-51	-41

The table is roughly arranged to place the more positive responses to the upper right. The values enclosed in parentheses in Table I are to be regarded with much less confidence than the others, since in these cases the magnitude of the signal was extremely variable—up to approximately 75% of the maximum. For this reason the data for the metal-free phthalocyanine was omitted from Figure 4 in the runs with water, ethanol, air and

benzene. Note the scale changes in Figure 4. Each tick mark on the vertical axes represents a 5 percent change in relative conductivity.

A detailed examination of the mechanisms of reaction of these vapors with the various types of phthalocyanines is beyond the scope of this work. The reader is directed to the papers by van Ewyk, Chadwick and Wright (15) or Langton and Day (12) for further information in this area. Experiments described here were conducted primarily to survey a series of materials under identical conditions in order to get a relative ranking of candidate materials for practical gas sensors, and to aid decisions about which monolayer-forming derivatives to synthesize.

A general characteristic of all the data shown in Figure 4 is the relatively slow initial response time and even slower return to baseline as the concentration of the test vapor was reduced. Because of the exponential dilution of vapor flowing to the sensor, the concentration dropped to 8.5% of its initial value after 25 minutes and to 0.3% of the initial value by the end of an hour. The sublimed films obviously do not equilibrate rapidly with the test vapors. This is a major reason for the interest in being able to deposit ultra-thin, ordered films by the Langmuir-Blodgett technique.

In spite of the slow response times, the sublimed films might be used in an alarm that responds to specific vapors. Since the electrodes being coated with these materials are so small, an array of many electrodes could be incorporated into a small sensor. Assuming an array of electrodes coated with the six materials shown in Table I, it is apparent that a distinct, recognizable pattern of maximum responses is produced by each of the test vapors. This is illustrated in Figure 5 by presenting the data of Table I as a bar graph. It would be a simple task to program a microcomputer to recognize these patterns.

Monolayer Films of Phthalocyanine Derivatives. We have been successful at preparing a series of derivatives of phthalocyanines that meet two important criteria of materials to be deposited by the Langmuir-Blodgett technique: (1) They must be soluble in a volatile organic solvent and (2) they must form monomolecular films on the surface of water. Characteristics of these monolayer films are reported here.

Monomolecular layers at the air/water interface are generally modeled as two-dimensional fluids. The classical film pressure vs. area curve is the two-dimensional analog of a pressure vs. volume isotherm for a gas. Real gases deviate from the ideal gas law, but it is still the primary equation used for

routine calculations. The lower the pressure the more closely a real gas resembles the ideal gas. Often  $P\bar{V}/RT$  is plotted versus  $P$  to display deviations from ideality at higher pressures. Since in the ideal case  $P\bar{V} = RT$  (where  $\bar{V}$  is the volume per mole), the plot intercepts the vertical axis at a value of 1. If instead of  $P\bar{V}/RT$ , only  $P\bar{V}$  is plotted against  $P$ , the vertical intercept is equal to  $RT$  at  $P = 0$ . For a gaseous monolayer film, ideally  $\pi A = kT$ , where  $\pi$  is the film pressure,  $A$  is the area per molecule, and  $k$  is the Boltzmann's constant. For a review of equations of state for insoluble monolayers see Gaines (18). A graph of  $\pi A$  vs.  $\pi$  for an ideal gaseous monolayer would be a horizontal line that intercepted the vertical axis at  $kT$ .

For real monolayer films we find that a very good fit to the values of  $\pi A$  vs.  $\pi$  can be made with a least squares best fit parabola through the data:

$$\pi A = C_0 + C_1 \pi + C_2 \pi^2 \quad (3)$$

This equation essentially assumes that spherical molecules are interacting and therefore does not fit the data perfectly in regions of the  $\pi$  vs.  $A$  curve where changes in molecular orientation are taking place. However, it is sufficiently good that the constants may be used to tabulate the  $\pi$  vs.  $A$  data for a large number of materials for comparison of general features.

This equation possesses another useful feature. It may be rewritten in a form somewhat resembling a van der Waals equation:

$$\pi (A - C_1) = C_0 + C_2 \pi^2. \quad (4)$$

In this form of the equation the constant  $C_1$  may be interpreted as a correction to the measured area due to the finite area occupied by the molecules on the surface. This interpretation is analogous to the interpretation of one constant in the van der Waals equation for gases as the correction for the finite volume of gas molecules. Even though monolayers such as stearic acid are believed to form films that are two-dimensional solids, the  $C_1$  values of area per molecule derived from the least squares best fit to Equation 3 agree with the accepted literature values determined by other methods.

A series of typical film pressure vs. area curves determined using our apparatus is shown in Figure 6. The dots indicate a series of points that were picked from the measured curves. The curves were determined by the least squares best fit to Equation 3. Curves for octadecanol (stearyl alcohol), platinum tetracumylphenoxy phthalocyanine (PtPcCp), and a mixture containing five molecules of octadecanol per molecule of PtPcCp are shown.

Table II summarizes the film pressure vs. area data for the various phthalocyanine derivatives that were studied. Of particular interest are values of  $C_1$ . A broad generalization based on

the C1 values would classify the phthalocyanine derivatives into two classes: Zn and Pt with areas per molecule near 75 square Angstroms and all the rest with areas per molecule near 50 square Angstroms.

Table II. Equation Constants for Surface Films of Phthalocyanine Derivatives

Metal (M)	M-tetracetylphenoxy phthalocyanines			M-tetraoctadecyl ether phthalocyanines		
	C0	C1	C2	C0	C1	C2
Zn	15.8	77.9	-1.204	--	--	--
Pt	14.6	74.3	-1.058	--	--	--
Ni	21.4	66.1	-0.819	19.3	50.5	-0.665
Cu	20.1	55.1	-0.660	23.2	60.9	-0.821
Pb	21.4	52.4	-0.613	13.8	49.0	-0.404
H <sub>2</sub>	19.5	51.0	-0.535	17.1	50.6	-0.813
Co	20.1	49.8	-0.838	--	--	--

The size of the basic phthalocyanine ring structure is well known (3). If it were lying horizontal on the water surface the molecule would occupy approximately 100 square Angstroms. To achieve areas less than this in a monolayer film, the molecules would have to be either inclined to the surface or stacked in some way. One possible interpretation is that the surface films of the phthalocyanine derivatives are composed of dimers as illustrated in Figure 7. Other orientations might also account

for the observed areas, but the proposed dimers have the characteristic that all oxygens are near the water surface and can interact with the water by hydrogen bonding in the same manner as classical surface films such as stearyl alcohol.

The postulated dimers would not necessarily have the metals aligned directly over each other. There is sufficient room in this model for variability in the exact alignment of the central metal atoms to account for the variations in the measured areas per molecule indicated by the Cl constants in Table II. Further study of deposited films of these phthalocyanine derivatives will be necessary in order to determine the exact orientations on the surface, but regardless of their orientations, they offer interesting possibilities for construction of ordered arrays of molecules on the surface of gas sensors.

We have just begun studies of the gas-sensing abilities of these films. To conduct such studies it is first necessary to transfer the material to a sensor surface. The compounds from this group of surface-active phthalocyanine derivatives that have been transferred to a solid surface (glass) so far, have produced rather non-uniform films compared to classical materials such as stearic acid. Since the phthalocyanine derivatives are highly colored, the irregularities in a many-monolayer Langmuir-Blodgett film may be observed visually. However, a mixed film of stearyl

alcohol and PtPcCp produced a uniform multilayer film when transferred to glass, so this mixture was also transferred to a microelectrode for electrical testing. The I-V curve for this film is shown in Figure 8. From this curve the surface resistivity of the mixed film at 1 volt was determined to be  $2.8 \times 10^{14}$  ohms/square. Similar tests for mixtures containing matrix films and other phthalocyanine derivatives are planned.

#### Summary and Conclusions

A survey of interactions of a series of vapors with coatings of metal-free and metal-substituted phthalocyanines sublimed onto the surface of microelectrodes indicated, as others have observed, that the conductivity of these materials was altered significantly in the presence of certain vapors. The central metal atom in the phthalocyanine molecule strongly influences the response of the compound to the challenging vapor. It has been possible to create a series of organic derivatives of the phthalocyanines that are soluble in volatile organic solvents and that form monolayer films on water surfaces. These materials can be transferred to solid surfaces, such as microelectrodes, by the Langmuir-Blodgett technique of passing the microelectrode repeatedly through the monolayer film. The ability to deposit multiple monolayer films of phthalocyanine derivatives offers the possibility of constructing precisely controlled thicknesses of

ordered arrays of molecules of these compounds on the surfaces of microsensors to make improved vapor-sensitive devices. Such films may have faster response and greater selectivity than the less well controlled, sublimed coatings.

#### Literature Cited

1. Wohltjen, H. and Dessy, R., Surface Acoustic Wave Probe for Chemical Analysis. I. Anal. Chem. 51, (9), 1458-1464, 1979.
2. Gaines, G.L., On the history of Langmuir-Blodgett Films, Thin Solid Films 99, (1,2,3), ix-xii, 1983.
3. Lever, A.P.B., The Phthalocyanines, in Emelius, H.J. and Sharpe, A.G., (Eds.), "Advances in Inorganic Chemistry and Radiochemistry, Vol. 7," Academic Press, New York, 1965, pp. 27-114.
4. Tollen, G., Kearns, D.R., and Calvin, M., Electrical properties of Organic Solids. I. Kinetics and Mechanism of Conductivity of Metal-Free Phthalocyanine, J. Chem. Phys. 32, 1013-1019, 1960.

5. Kearns, D.R., Tollin, G., and Calvin, M., Electrical properties of organic solids II. Effects of added electron acceptor on metal-free phthalocyanine, J. Chem. Phys. 32, 1020-1025, 1960.
6. Ukei, K., Takamoto, K., and Kanda, E., Lead phthalocyanine: a one-dimensional conductor, Physics Letters 45A, (4), 345-346, 1973.
7. Ukei, K., Electroconductive properties of a one-dimensional conductor lead phthalocyanine, J. Physical Soc. Jap. 40, 140-143, 1976.
8. Hamann, C., Hohne, H.-J., Kersten, F., Muller, M., Przyborowski, F., and Starke, M., Switching effects on polycrystalline films of lead phthalocyanine (PbPc), Phys. Stat. Sol. (a) 50, K189-K192, 1978.
9. Yasunaga, H., and Shintaku, H., Effect of Schottky barrier on alternating current response of lead phthalocyanine, J. Appl. Phys. 51 (4) 2149-2152, 1980.
10. Yasunaga, H., Kojima, K., Yohda, H., and Takeya, K., Effect of oxygen on electrical properties of lead phthalocyanine, J. Phys. Soc. Jap. 37 (4) 1024-1030, 1974.

11. Yasunaga, H., Kasai, K. and Kenichi, T., Oxygen induced photoconductivity in lead phthalocyanine, J. Phys. Soc. Jap. 46 (3) 839-845, 1979.
12. Langton, J. and Day, P., Effect of adsorbed gases on the dark photoconductivity of Fe(II) phthalocyanine crystals, J. Chem. Soc., Faraday Trans. 2; 78, 1675-1685, 1982.
13. Beales, K.J., Eley, D.D., Hazeldine, D.J., and Palmer, T.F., Metal phthalocyanines of the first transition period, in Kropf, H., and Steinbach, F., (Eds.), ''Katalyse an Phthalocyaninen'', Georg Thieme Verlag, Stuttgart, 1973, pp.1-32.
14. Sadaoka, Y., Yamazoe, N., and Seiyama, T., A gas sensor using thin films of phthalocyanine, Denki Kagaku Oyoji Kagaku Butsuri Kagaku 46 (11) 597-602, 1978. (Abstract and figures in English.)
15. van Ewyk, R.L., Chadwick, A.V., and Wright, J.D., Electron donor-acceptor interactions and surface semiconductivity in molecular crystals as a function of ambient gas, J.C.S. Faraday I; 76, 2194-2205, 1980.

16. Baker, S., Petty, M.C., Roberts, G.G., and Twigg, M.V., The preparation and properties of stable metal-free phthalocyanine Langmuir-Blodgett films, Thin Solid Films 99 (1,2,3) 53-59, 1983.
  
17. Barger, W.R., Daniel, W.H., and Garrett, W.D., Surface chemical properties of banded sea slicks, Deep-Sea Research 21, 83-89, 1974.
  
18. Gaines, G.L., ''Insoluble Monolayers at Liquid-Gas Interfaces'', Interscience, New York, 1966.

Figure 1. Schematic diagrams of a microelectrode and a surface acoustic wave (SAW) device.

Figure 2. Low dead-volume flow-through cell for a coated microelectrode vapor sensor.

Figure 3. Arrangement of experimental apparatus for electrical measurements on sublimed phthalocyanine films.

Figure 4. Changes in relative conductivity as a function of time for sublimed phthalocyanine films exposed to a series of test vapors. The chemical symbols for metals identify the type of phthalocyanine.  $H_2$  indicates metal-free phthalocyanine. Concentration as a percent of initial concentration is shown vs. time for the challenging vapors.

Figure 5. Data from Table I plotted as a bar graph to illustrate the distinct, recognizable patterns that would be observed by an array of 6 microelectrodes. Symbols at the top indicate the type of sublimed phthalocyanine exposed to the listed vapors.

Figure 6. Typical film pressure vs. area isotherms. Stearyl alcohol = octadecanol. PtPcCp = platinum tetra-cumylphenoxy phthalocyanine.

Figure 7. Illustration of the postulated geometrical arrangement of molecules in the surface films of phthalocyanine derivatives spread on water surfaces. The dimer structures at the bottom of the figure could account for the observed areas per molecule.

Figure 8. I-V curve for a microelectrode coated with 71 layers of a mixed monolayer film of 5 molecules of stearyl alcohol per molecule of platinum tetracumylphenoxy phthalocyanine. The electrode had 300 finger pairs with gaps of 0.7  $\mu\text{m}$  x 1700  $\mu\text{m}$ .

# MICRO ELECTRODE

300 FINGER PAIRS

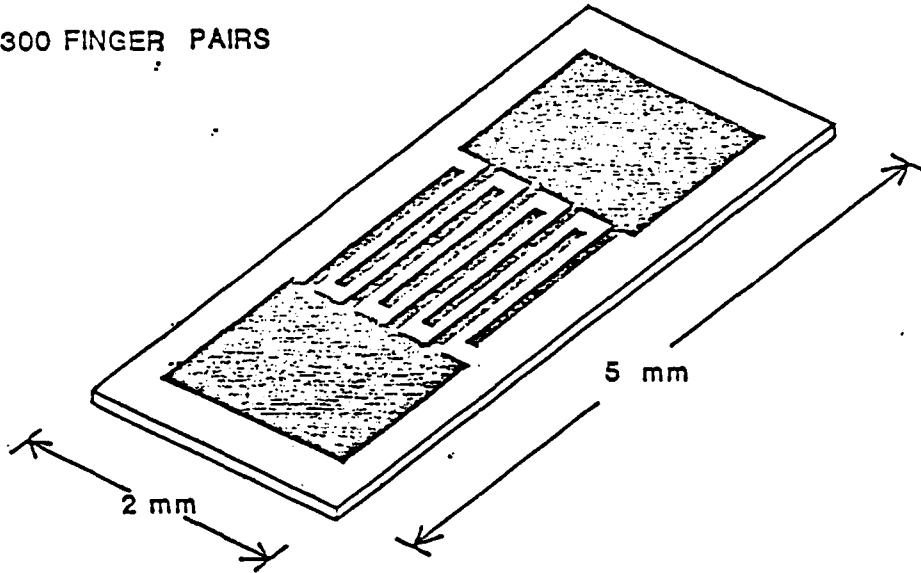

# SAW DEVICE

50 FINGER PAIRS

25  $\mu\text{m}$  wide

25  $\mu\text{m}$  gap

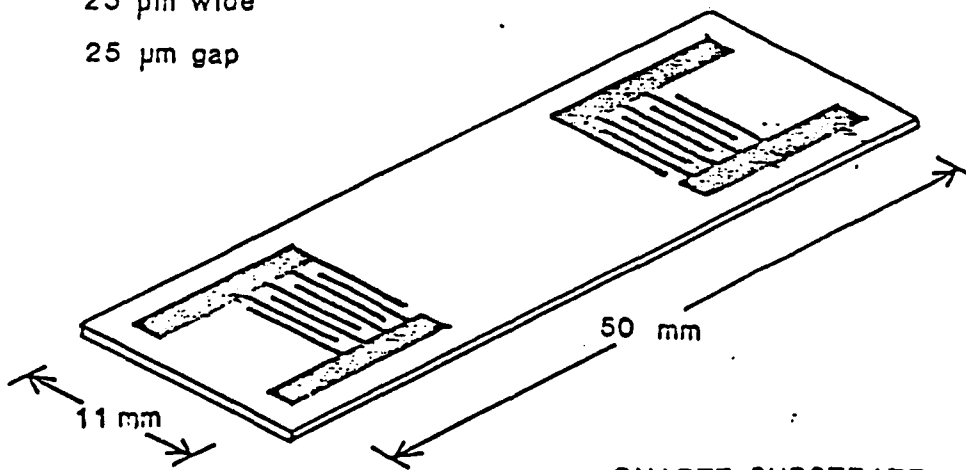

QUARTZ SUBSTRATE

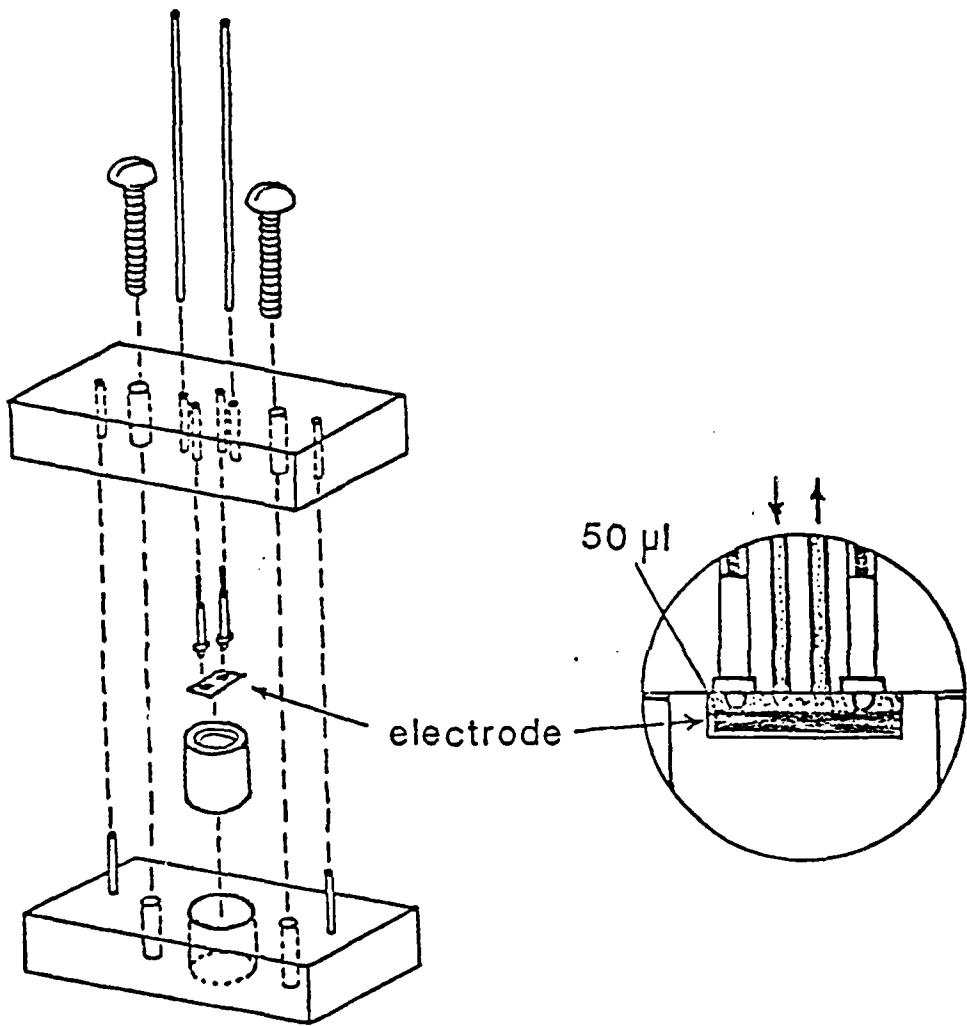



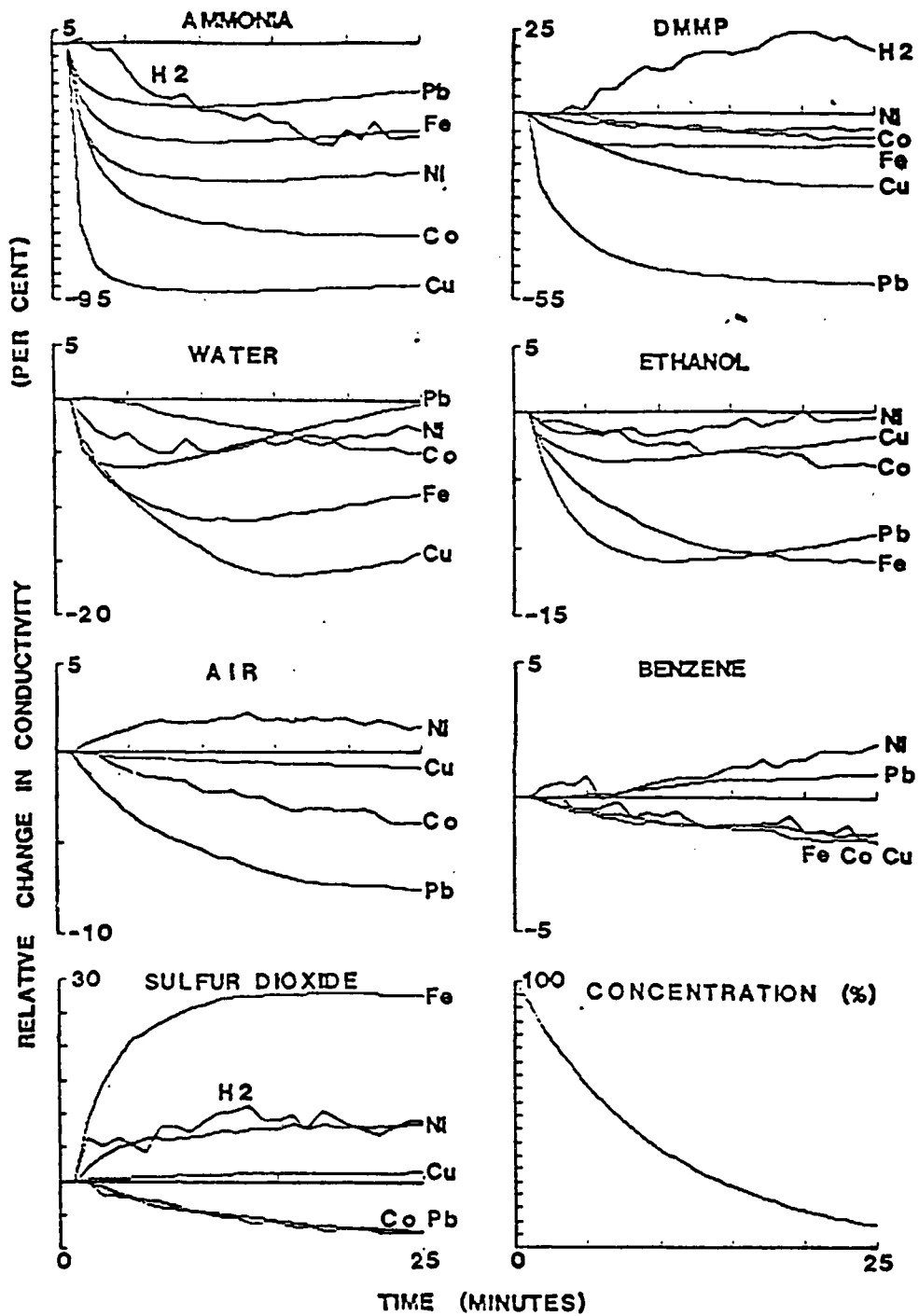

H2 NI PB FE CU CO

AMMONIA

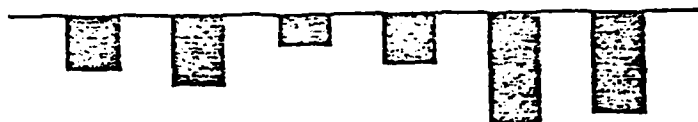

DMMP



WATER

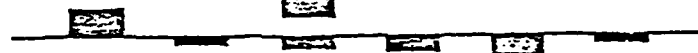

ETHANOL

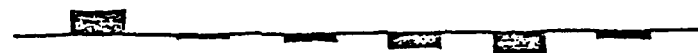

AIR



BENZENE



SO2



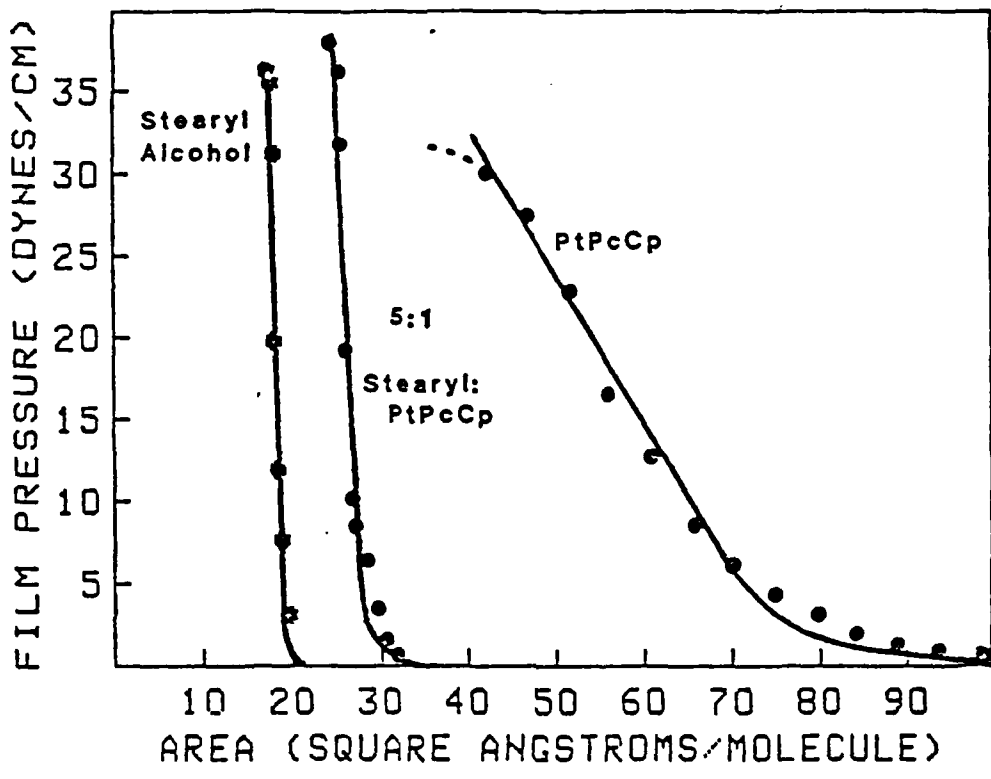

$\approx 100 \text{ \AA}^2$   
molecule

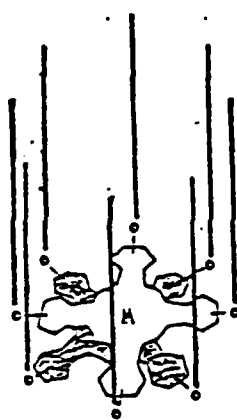
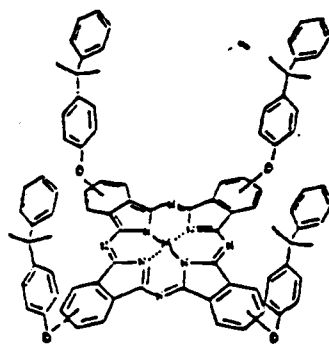
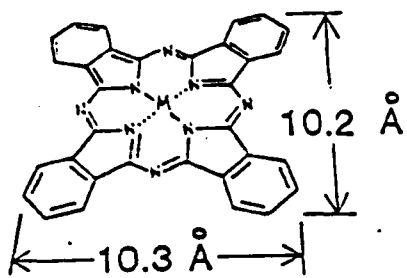

$\approx 50 \text{ \AA}^2$   
molec

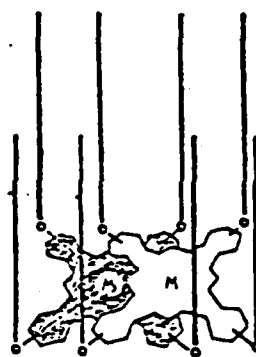

$\approx 75 \text{ \AA}^2$   
molec

