

MICROCOPY RESOLUTION TEST CHART  
NATIONAL BUREAU OF STANDARDS - 1963 - A

ADA130710

REPORT DOCUMENTATION PAGE		READ INSTRUCTIONS BEFORE COMPLETING FORM
1. REPORT NUMBER NRL Memorandum Report 5143	2. GOVT ACCESSION NO. AD A130710	3. RECIPIENT'S CATALOG NUMBER
4. TITLE and Subtitle: ON THE APPLICATION OF OPTICAL SIGNAL PROCESSING TO THE SOLUTION OF RICCATI EQUATIONS	5. TYPE OF REPORT & PERIOD COVERED Interim report on a continuing NRL problem.	
	6. PERFORMING ORG. REPORT NUMBER	
7. AUTHOR(s) H. N. Ho	8. CONTRACT OR GRANT NUMBER(s)	
9. PERFORMING ORGANIZATION NAME AND ADDRESS Naval Research Laboratory Washington, DC 20375	10. PROGRAM ELEMENT PROJECT, TASK AREA & WORK UNIT NUMBERS 62712N; XF12-143-091; 67956-6010	
11. CONTROLLING OFFICE NAME AND ADDRESS Naval Electronic Systems Command Washington, DC 20360	12. REPORT DATE July 21, 1983	
	13. NUMBER OF PAGES 21	
14. MONITORING AGENCY NAME & ADDRESS (if different from Controlling Office)	15. SECURITY CLASS. (of this report) UNCLASSIFIED	
	15a. DECLASSIFICATION/DOWNGRADING SCHEDULE	
16. DISTRIBUTION STATEMENT (of this Report)  Approved for public release; distribution unlimited.		
17. DISTRIBUTION STATEMENT (of the abstract entered in Block 20, if different from Report)		
18. SUPPLEMENTARY NOTES		
19. KEY WORDS (Continue on reverse side if necessary and identify by block number)  Optical signal processing Riccati equation solution Iterative solution of matrix equations		
20. ABSTRACT (Continue on reverse side if necessary and identify by block number)  → The Riccati equation encountered in continuous Kalman filtering is studied. For the case of a system with constant (or piecewise constant) coefficient matrices the solution of the Riccati equation is presented in the form of a recursive relationship that does not require matrix inversion. A functional design of an iterative optical processor for performing the recursive solution of the Riccati equation is presented. Certain other issues of optical signal processing such as handling of bipolar or complex data and techniques for increased accuracy are also briefly discussed. ←		

CONTENTS

I. INTRODUCTION ..... 1

II. RICCATI EQUATION IN KALMAN FILTERING ..... 2

III. SOLUTION OF RICCATI EQUATION..... 5

IV. DESCRIPTION OF OPTICAL SYSTEM ..... 7

V. SUMMARY AND DISCUSSIONS ..... 17

VI. ACKNOWLEDGEMENTS..... 17

VII. LIST OF REFERENCES..... 18

**S** DTIC ELECTE **D**  
JUL 26 1983  
**B**

FIG  
COPY  
INSPECTED  
g

Accession For	
NTIS GRA&I	<input checked="" type="checkbox"/>
DTIC TAB	<input type="checkbox"/>
Unannounced	<input type="checkbox"/>
Justification	<input type="checkbox"/>
By _____	
Distribution/	
Availability Codes	
Dist	Avail and/or Special
<b>A</b>	

ON THE APPLICATION OF OPTICAL SIGNAL PROCESSING  
TO THE SOLUTION OF RICCATI EQUATIONS

I. INTRODUCTION

Riccati equations are coupled, nonlinear differential equations which often arise in the analysis and design of modern communication and control systems. In communications, Riccati equations are encountered in problems of optimal filtering [1]. In controls, these equations arise in the linear regulator problem [2], in servo-mechanism design and Kalman filtering [3].

The solutions of the Riccati equations has been extensively studied by numerous investigators. The general solution to the Riccati equations is quite difficult, because these equations may be of large dimensions (of order 50 or more) and are coupled, nonlinear equations. The advent of large scale computers has permitted some progress in the solution of Riccati equations, but the computational burden is still quite severe. Thus, real-time or near real-time solution of these equations by digital computations is presently not feasible except for limited cases where the dimension of the equation is small. Recently, some computer algorithms have been presented for the algebraic Riccati equation (ARE), which is the steady state solution. Among these algorithms are those proposed by Pappas and Laub [4] using the generalized eigenvalue approach, and by Laub [5] where he uses a variant of the classical eigenvector approach, by the so-called Schur vectors method.

Optical signal processing, because of its capacity for high speed parallel operations using relatively simple hardware, has emerged as a promising candidate for solving problems in modern communications and controls. Various forms of optical signal processing architecture have evolved from systems designed for vector-matrix, matrix-matrix operations [6-9] and eigenvector determination [10,11]. These systems are often

Manuscript approved June 13, 1983.

hybrid electro-optical systems because the hardware include digital and analog electronics. In the specific area of modern controls, Casasent et al [12] described an iterative optical processor (IOP) for solving the ARE by implementing a revision of the Kleinman and Richardson algorithms. This IOP architecture required a 2-D spatial light modulator (SLM) mask with a typical refresh time of 30 msec, thus the processing speed is limited by this SLM mask refresh time. In their search for systems with higher speeds, Casasent et al described an architecture [13] which avoids the use of 2-D SLM masks. This system was applied to the problem of the discrete Kalman Filtering, which is also suitable for computer solutions. While the discrete Kalman Filtering is useful where discrete measurements samples are encountered, continuous Kalman Filtering is important when a continuous process must be estimated or observed, for example, in the shape of large space structures.

In this report, we describe an optical signal processing technique for the solution of the continuous Riccati equation in Kalman filtering. Unlike previous algorithmic techniques [4,5, and 12], the optical technique proposed here will give the transient as well as the steady-state solutions. Using the great power of parallel processing inherent in optical system, the solution of Riccati equations is expected to be in near real-time.

## II. RICCATI EQUATION IN KALMAN FILTERING

In Figure 1, the simplified functional block diagram of a continuous Kalman filter is shown. In this figure,  $\underline{x}(t)$  is a N-dimensional vector which represents the state of a system of interest,  $\hat{\underline{x}}(t)$  is the estimate of  $\underline{x}(t)$ , which is computed from the set of Nx1 measurements,  $\underline{z}(t)$ .  $F(t)$  and  $H(t)$  are NxN matrices which are called the system and measurement matrices, respectively. The system and measurement noise vectors,  $\underline{w}(t)$  and  $\underline{v}(t)$ , are Nx1 vectors. In the right side of figure 1,  $K(t)$  is the NxN "Kalman gain" matrix, and it is known that  $K(t)$  is dependent upon  $F(t)$  by [3],

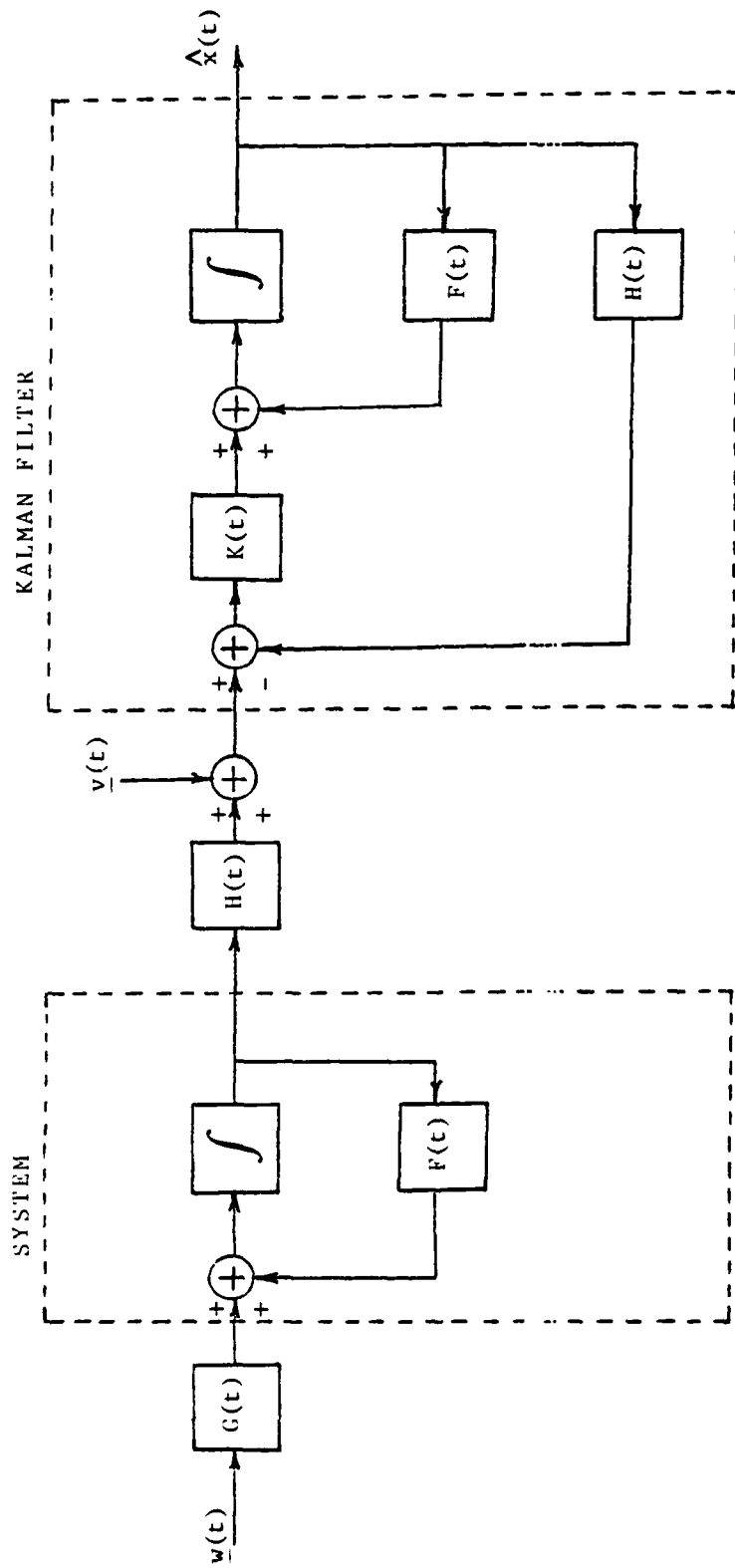

Fig. 1 - Functional block diagram of Continuous Kalman Filter

$$K(t) = P(t) H^T(t) R^{-1}(t), \quad (1)$$

where  $P(t)$  is the solution of the Riccati equation,  $H^T(t)$  denotes transpose of  $H(t)$ ,  $R^{-1}(t)$  is the inverse of  $R(t)$ . In (1) we assumed  $\underline{v}(t)$  and  $\underline{w}(t)$  are uncorrelated and  $R(t)$  is symmetrical. Thus from [3]

$$\dot{P} = FP + PF^T + GQG^T - PH^T R^{-1} HP, \quad P(t_0) \text{ given}, \quad (2)$$

where  $\dot{P}$  denotes a time derivative,  $P(t_0)$  is the known initial value matrix and  $\underline{w}(t)$  and  $\underline{v}(t)$  are assumed Gaussian processes with

$$\begin{aligned} E[\underline{w}(t)] &= \underline{0}, & E[\underline{w}^2(t)] &= Q(t) \\ E[\underline{v}(t)] &= \underline{0}, & E[\underline{v}^2(t)] &= R(t), \end{aligned} \quad (3)$$

with  $E[\ ]$  denoting taking the expected value. The initial condition  $P(t_0)$  is defined by

$$E [ (\underline{x}(o) - \hat{\underline{x}}(o)) (\underline{x}(o) - \hat{\underline{x}}(o))^T ], \quad (4)$$

where  $E[\underline{x}(o)] = \hat{\underline{x}}(o)$ . The correlation between  $\underline{w}(t)$  and  $\underline{v}(t)$  is given by

$$E [\underline{w}(t) \underline{v}^T(t)] = 0. \quad (5)$$

If we assume  $R(t)$  is positive definite, then  $R(t)$  is invertible and the solution of (1) is assured.

### III. SOLUTION OF RICCATI EQUATION

The system of N nonlinear coupled equations of (2) is quite difficult to solve. However, if the coefficients of (2) (i.e., F, G, H, and R) are constants (or piecewise constants), then by considering the following transforms,

$$\underline{\lambda} = P\underline{y} \quad (6)$$

and

$$\dot{\underline{y}} = -F^T \underline{y} + H^T R^{-1} H P \underline{y} \quad , \quad (7)$$

and taking a derivative of (6) with respect to time will yield

$$\begin{aligned} \dot{\underline{\lambda}} &= \dot{P}\underline{y} + P\dot{\underline{y}} \\ &= (FP + PF^T + GQG^T - PH^T R^{-1} HP) \underline{y} + P[-F^T \underline{y} + H^T R^{-1} H P \underline{y}] \\ &= F\underline{\lambda} + GQG^T \underline{y}. \end{aligned} \quad (8)$$

From (7) and (8), it is clear the matrix equations in  $\underline{\lambda}$  and  $\underline{y}$  can be written as

$$\begin{bmatrix} \dot{\underline{y}} \\ \dot{\underline{\lambda}} \end{bmatrix} = \begin{bmatrix} -F^T & H^T R^{-1} H \\ \underbrace{GQG^T \quad F}_M \end{bmatrix} \begin{bmatrix} \underline{y} \\ \underline{\lambda} \end{bmatrix} \quad , \quad (9)$$

which is a 2N order linear system of equations, that is much simpler than the system of N nonlinear coupled equations of (2). From linear system theory, it is known the system of (9) can be written as  $\Phi(\tau) = \exp(M\tau) = \Phi(t_0 + \tau, t_0)$ , where  $\Phi(\tau)$  is the transition matrix. Thus we can write [3] as

$$\begin{bmatrix} \underline{y}(t_0 + \tau) \\ \underline{\lambda}(t_0 + \tau) \end{bmatrix} = \begin{bmatrix} \phi_{yy}(\tau) & \phi_{y\lambda}(\tau) \\ \phi_{\lambda y}(\tau) & \phi_{\lambda\lambda}(\tau) \end{bmatrix} \begin{bmatrix} \underline{y}(t_0) \\ \underline{\lambda}(t_0) \end{bmatrix}, \quad (10)$$

where  $\phi(\tau)$  is partitioned into square  $N \times N$  matrices. Using the relation in (6) and (10), it can be shown

$$\underline{\lambda}(t_0 + \tau) = p(t_0 + \tau) \underline{y}(t_0 + \tau), \quad (11)$$

from which

$$p(t_0 + \tau) = \frac{\phi_{\lambda y}(\tau) + \phi_{\lambda\lambda}(\tau) \frac{\underline{\lambda}(t_0)}{\underline{y}(t_0)}}{\phi_{yy}(\tau) + \phi_{y\lambda}(\tau) \frac{\underline{\lambda}(t_0)}{\underline{y}(t_0)}} \quad (12)$$

$$P(t_0 + \tau) = [\phi_{\lambda y}(\tau) + \phi_{\lambda\lambda}(\tau) p(t_0)] [\phi_{yy}(\tau) + \phi_{y\lambda}(\tau) p(t_0)]^{-1}$$

In (12),  $P(t_0)$  is assumed known a priori and the matrix multiplication and addition may be performed by digital techniques or by combination of digital-optical techniques. To solve equation 12 we note it is in the form

$$P = WS^{-1} \quad (13)$$

This matrix equation can be solved by an iterative procedure without having to invert  $S$ . Suppose we let  $P_{i+1}$  be the  $(i+1)^{\text{th}}$  iteration. Then

$$P_{i+1} = W + P_i (I-S), \quad (14)$$

where  $I$  is the identity matrix and  $P_i$  is the  $i^{\text{th}}$  iteration. When  $P_{i+1} = P_i$ , (14) reduces to (13) and the system's output is  $P$ . Thus, the solution  $P$  is obtained without having to invert  $S$ .

#### IV. DESCRIPTION OF OPTICAL SYSTEM

Consider Fig. 2, which shows the proposed optical system for solving (13). This system is called the outer product, matrix-matrix multiplier, iterative optical processor (OIOP) and it is designed to solve the iterative algorithm of (14). This system consists of the outer product matrix-matrix multiplier (due to Athale and Collins [14]) which computes the matrix product  $P_i(I-S)$ , an electronic adder to add  $W$  and a comparator which compares the  $i^{\text{th}}$  iteration ( $P_i$ ) with the  $(i+1)^{\text{th}}$  iteration ( $P_{i+1}$ ). Functionally, we start by setting  $P_i = P_0$  as the initial value of  $P$ . This value  $P_0$  is then summed with  $W$  to form

$$P_{i+1} = P_0 + W. \quad (15)$$

Assuming  $W \neq 0$ , the comparator would decide  $P_{i+1} \neq P_i$  and the iteration  $P_{i+2} = P_{i+1}(I-S) + W$  would be performed. This iterative procedure continues until  $P_{j+1} = P_j$  at which time the comparator decides the solution is obtained. We now proceed to discuss functions of the outer product matrix-matrix multiplier and the comparator circuit.

##### A. Outer Product Matrix-Matrix Multiplier

The outer product matrix-matrix multiplier system was introduced by Athale and Collins [14] to perform optical matrix-matrix multiplication. This system consists of two I-D acousto-optic (AO) cells placed orthogonal to each other and a square array of  $N \times N$  detectors, where  $N$  is dimension of the matrix. This system, as shown in Fig. 3, operates in the following manner. Let  $C = AB$  be the matrix-matrix multiplication. For the case where

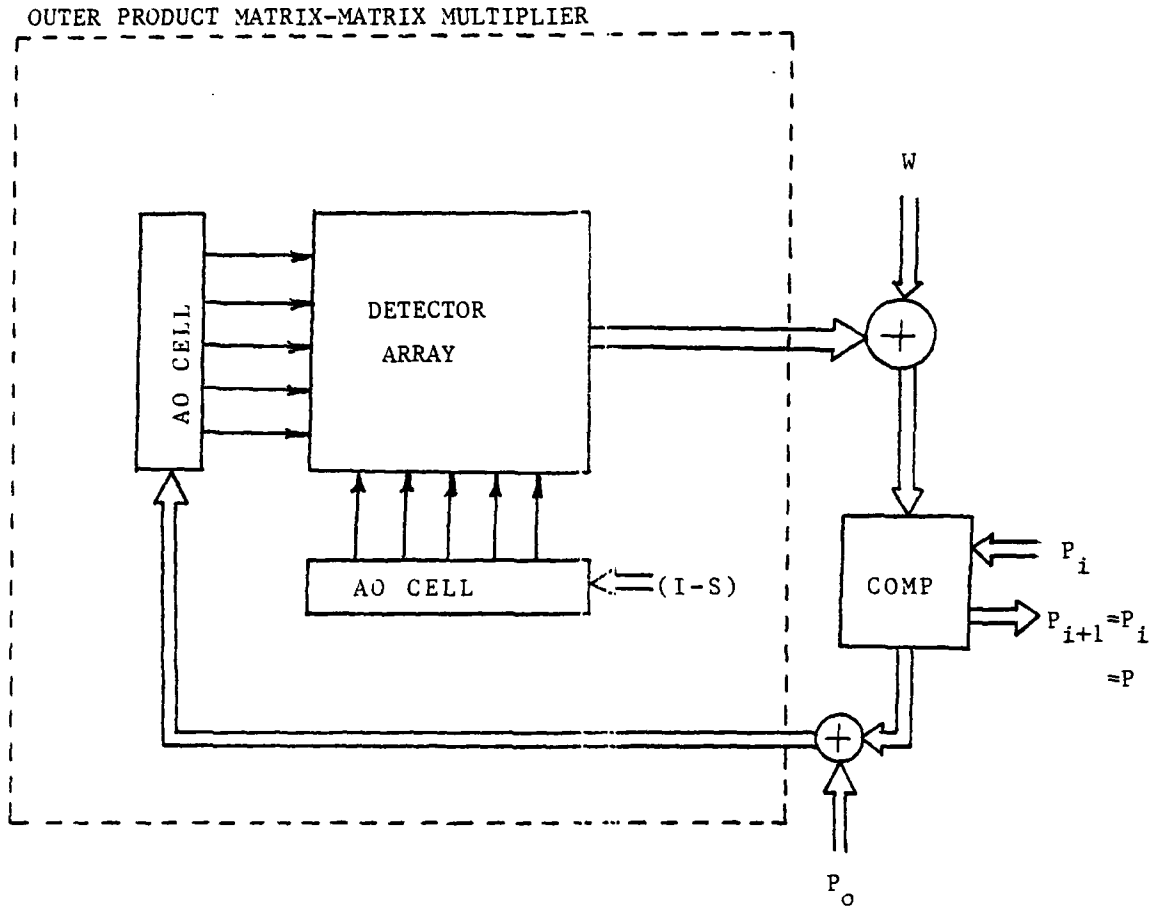

Fig. 2 - Functional block diagram of outer product matrix-matrix multiplier iterative optical processor (OIOP).

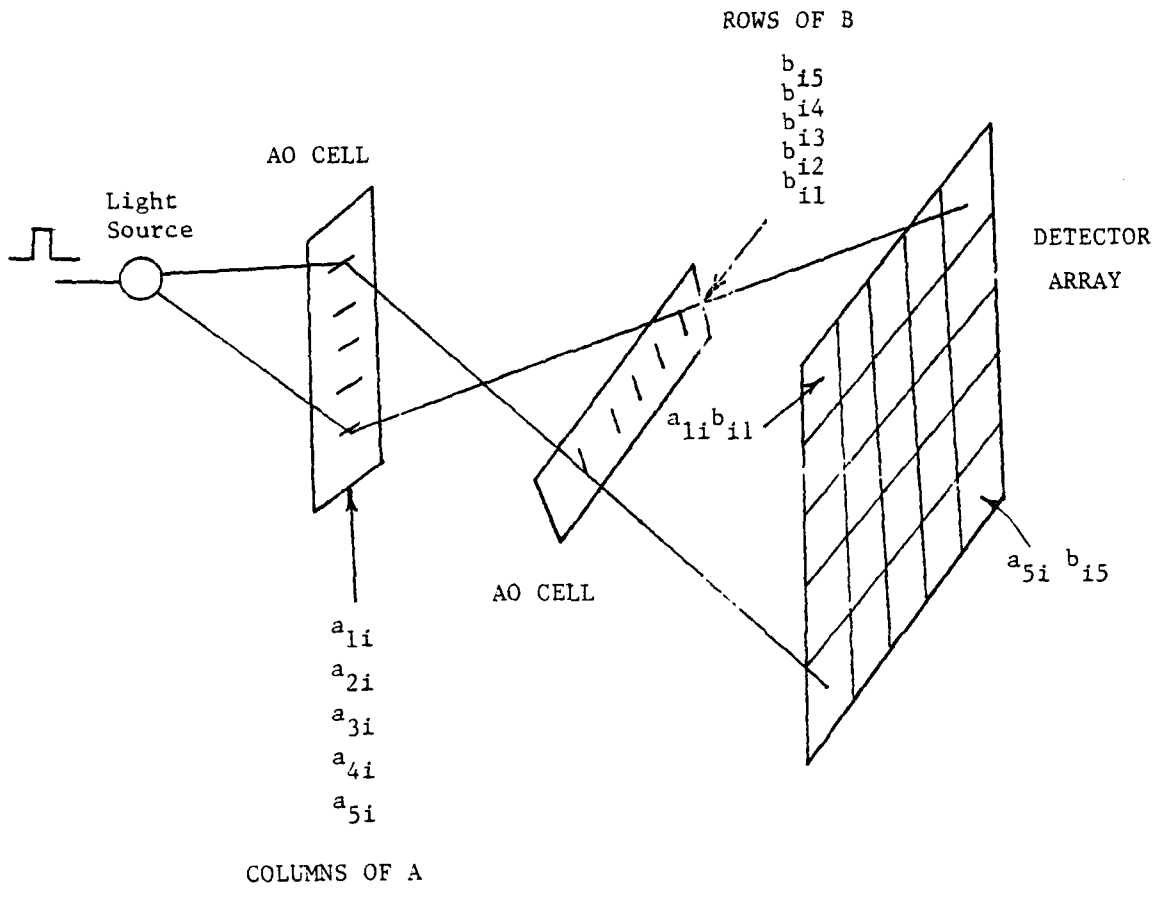

Fig. 3 - Outer product matrix-matrix multiplier using serial feed.

A and B are 5x5 square matrices, the  $i$ th column of A and the  $i$ th row of B are inserted in sequence into the respective AO cells. At the instant when both cells are filled, the light source S is strobed to effectively freeze the contents of the AO cells. Thus the output detector will realize the outer product

$$\begin{array}{c}
 \left[ \begin{array}{ccccc}
 b_{i1} & b_{i2} & b_{i3} & b_{i4} & b_{i5}
 \end{array} \right] \\
 \\
 \left[ \begin{array}{c}
 a_{1i} \\
 a_{2i} \\
 a_{3i} \\
 a_{4i} \\
 a_{5i}
 \end{array} \right] \\
 \\
 = \left[ \begin{array}{ccccc}
 a_{1i}b_{i1} & a_{1i}b_{i2} & a_{1i}b_{i3} & a_{1i}b_{i4} & a_{1i}b_{i5} \\
 a_{2i}b_{i1} & a_{2i}b_{i2} & a_{2i}b_{i3} & a_{2i}b_{i4} & a_{2i}b_{i5} \\
 a_{3i}b_{i1} & a_{3i}b_{i2} & a_{3i}b_{i3} & a_{3i}b_{i4} & a_{3i}b_{i5} \\
 a_{4i}b_{i1} & a_{4i}b_{i2} & a_{4i}b_{i3} & a_{4i}b_{i4} & a_{4i}b_{i5} \\
 a_{5i}b_{i1} & a_{5i}b_{i2} & a_{5i}b_{i3} & a_{5i}b_{i4} & a_{5i}b_{i5}
 \end{array} \right] \quad (16)
 \end{array}$$

If successive outer products between the columns of A and rows of B (for  $i = 1, 2, 3, 4, 5$ ) are formed (as shown in (16)) and the results summed at the detector array by using time integrating detector elements (such as charge coupled devices) the matrix-matrix product  $C = AB$  will be realized. To perform rapid matrix-matrix multiplication, the row-column, vector-vector multiplication indicated by (16) can be performed by inserting the matrix elements in parallel. Thus we feed the columns of A ( $a_i$ )  $i=1, 2, \dots, 5$ ), and the rows of B ( $b_i$ ,  $i = 1, 2, \dots, 5$ ) in parallel to the respective AO cells (as shown in figure 4). When  $a_i$ 's and  $b_i$ 's are properly positioned in the AO cells the light source is strobed to provide the detector array output shown in (16). Successive column-row outer products are formed and summed at the detector array, as previously described, to obtain the matrix-matrix product  $C = AB$ . For large dimension square matrices of order N the parallel feed system of Fig. 4 is N times faster than the series feed system of Fig. 3.

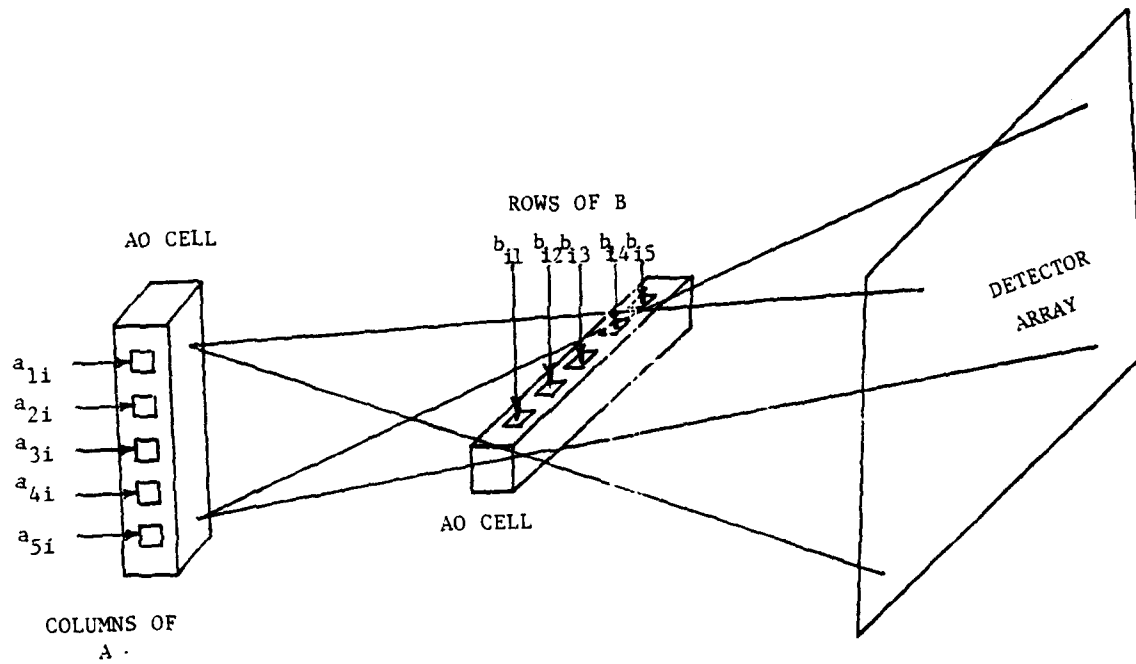

Fig. 4 - Outer product matrix-matrix multiplier for  $C=AB$  using parallel feed.

Because the OIOP performs operations on positive real information, bipolar or complex data must be first transformed or rescaled to contain positive-real data components.

### B. Bipolar Data

Casasent [12] shows a method to handle bipolar data. Let us consider the vector matrix product

$$\underline{y} = H\underline{x} \quad (17)$$

where  $\underline{y}$  and  $\underline{x}$  are  $N \times 1$  vectors and  $H$  is a  $N \times N$  matrix. The concept can easily be extended to matrix-matrix multiplications. Let  $h_{mn}$  be an element of  $H$ . We define a new matrix  $B$  with positive real elements, whereby

$$b_{mn} = \frac{h_{mn} - \underline{h}}{\bar{h} - \underline{h}}, \quad (18)$$

where  $\underline{h}$  and  $\bar{h}$  are respectively the minimum and maximum values of  $H$ . Clearly  $0 < b_{mn} < 1$ . To handle the bipolar data, we decompose each element of the bipolar input vector  $\underline{x}$  into its positive  $\underline{x}^+$  and negative  $\underline{x}^-$  components to form

$$a_{1m} = 0.5 (x_m + |x_m|) \quad (19a)$$

$$a_{2m} = 0.5 (-x_m + |x_m|), \quad (19b)$$

where  $m = 1, 2, \dots, N$ . From (19),  $\underline{a}_1 = \underline{x}^+$  and  $\underline{a}_2 = \underline{x}^-$  are both positive real and it can be noted that

$$\underline{x} = \underline{a}_1 - \underline{a}_2 \quad (20)$$

Equation (19b) above differs from Eq. 6 of Ref. [12], which indicates  $a_{2m} = 0.5(x_m - |x_m|)$  that is apparently in error. To illustrate the use of (20) by a simple example, consider  $\underline{x}^T = (x_1, x_2) = (5, -5)$ . Then by (19) above

$$a_{11} = 0.5 (5 + |5|) = 5 \quad , \quad a_{12} = 0.5 (-5 + |-5|) = 0 \quad (21)$$

$$a_{21} = 0.5 (-5 + |5|) = 0 \quad , \quad a_{22} = 0.5 (5 + |5|) = 5$$

Thus  $\underline{a}_1^T = (5, 0)^T$  and  $\underline{a}_2^T = (0, 5)^T$  are both positive real and

$\underline{x} = \underline{a}_1 - \underline{a}_2 = (5, -5)^T$  is satisfied.

An implementation for the system  $\underline{y} = H\underline{x}$  in terms of  $\underline{a}_1$  and  $\underline{a}_2$  can be given. First, note

$$H = (\bar{h} - \underline{h}) B + \underline{h} \quad (22)$$

thus

$$\underline{y} = (\bar{h} - \underline{h}) B (\underline{a}_1 - \underline{a}_2) + \underline{h} \underline{x} \quad (23)$$

The desired system for bipolar data in vector matrix multiplication as indicated by (23) is shown in Fig. 5.

### C. Complex Data

A method for handling complex data in outer-product matrix-matrix multiplication was shown by Taraseviich et al [15]. In this method the outer product of complex vectors  $\underline{a}$  and  $\underline{b}$  with positive real components are performed as follows

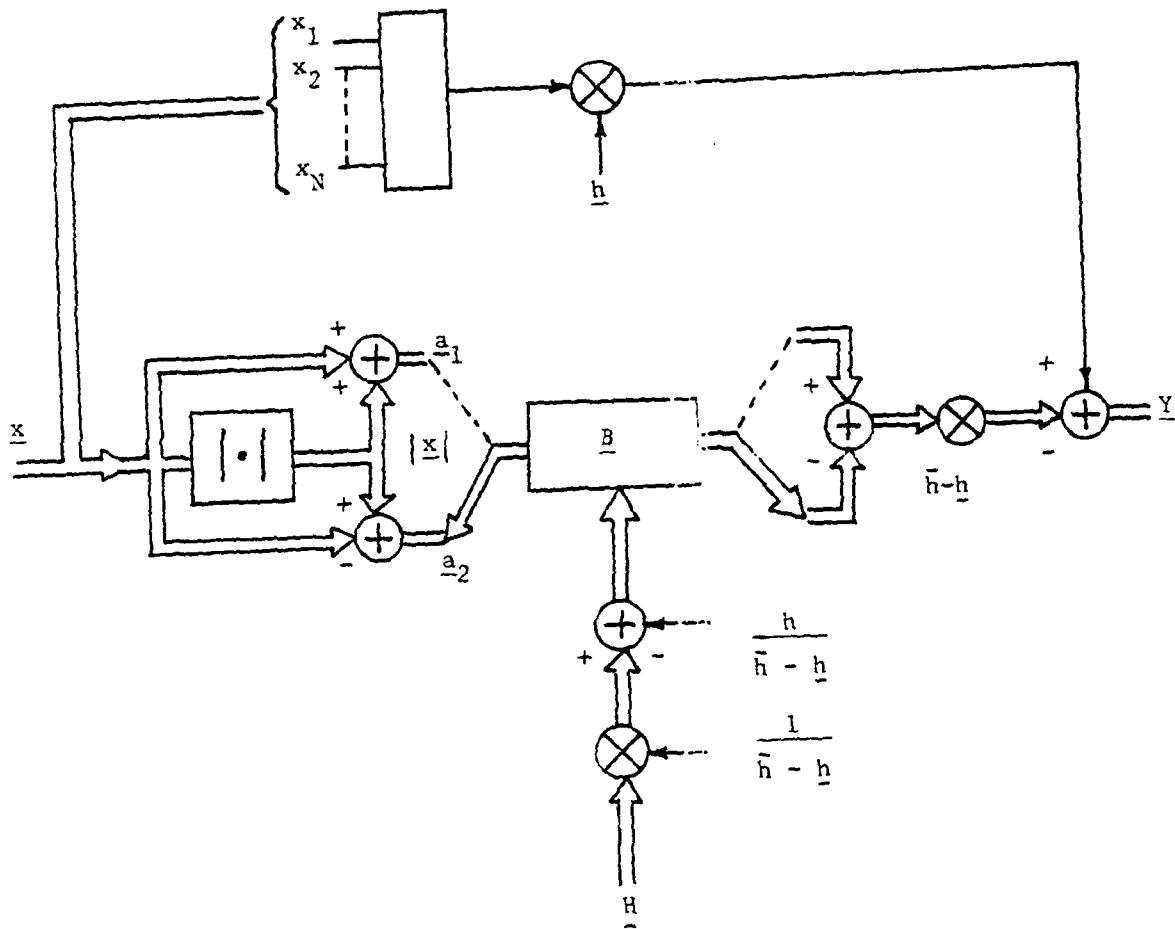

Fig. 5 - Functional block diagram of bipolar vector-matrix multiplier

$$\underline{a} = \underline{a}_0 + \underline{a}_1 e^{j 2\pi/3} + \underline{a}_2 e^{j 4\pi/3} \quad (24a)$$

$$\underline{b} = \underline{b}_0 + \underline{b}_1 e^{j 2\pi/3} + \underline{b}_2 e^{j 4\pi/3} \quad (24b)$$

$$\underline{M} = \underline{a} \underline{b}^T = \underline{M}_0 + \underline{M}_1 e^{j 2\pi/3} + \underline{M}_2 e^{j 4\pi/3}, \quad (24c)$$

where T denotes conjugate - transpose. Carrying out the multiplication of (24c), it can be shown

$$\underline{M}_0 = \underline{a}_0 \underline{b}_0^T + \underline{a}_1 \underline{b}_2^T + \underline{a}_2 \underline{b}_1^T \quad (25a)$$

$$\underline{M}_1 = \underline{a}_0 \underline{b}_1^T + \underline{a}_1 \underline{b}_0^T + \underline{a}_2 \underline{b}_2^T \quad (25b)$$

$$\underline{M}_2 = \underline{a}_0 \underline{b}_2^T + \underline{a}_2 \underline{b}_0^T + \underline{a}_1 \underline{b}_1^T. \quad (25c)$$

We note that the complex-valued outer product  $M = \underline{a} \underline{b}^T$  will require the evaluation of nine outer products of the non-negative-real components  $\underline{a}_i \underline{b}_j^T$ , where  $i, j = 0, 1, 2$ . Fortunately, these nine outer products can be evaluated as a single larger outer product of the form

$$\begin{bmatrix} \underline{a}_0 \\ \underline{a}_1 \\ \underline{a}_2 \end{bmatrix} \begin{bmatrix} \underline{b}_0^T & \underline{b}_1^T & \underline{b}_2^T \end{bmatrix} = \begin{bmatrix} \underline{a}_0 \underline{b}_0^T & \underline{a}_0 \underline{b}_1^T & \underline{a}_0 \underline{b}_2^T \\ \underline{a}_1 \underline{b}_0^T & \underline{a}_1 \underline{b}_1^T & \underline{a}_1 \underline{b}_2^T \\ \underline{a}_2 \underline{b}_0^T & \underline{a}_2 \underline{b}_1^T & \underline{a}_2 \underline{b}_2^T \end{bmatrix}. \quad (26)$$

In the above implementation nine times as many detector elements are required and additional electronic circuitry is needed to sum the individual outer product components to obtain the desired result of (25c).

More economical use of the optical system space-bandwidth product can be made if the complex data is represented by its biased real-imaginary form [16]. For example, the outer product  $\underline{a} \underline{b}^T$  is

$$\text{Let } \underline{a} = \underline{a}_r + j\underline{a}_i \quad (27a)$$

$$\underline{b} = \underline{b}_r + j\underline{b}_i, \quad (27b)$$

$$M = \underline{a} \underline{b}^T = \underline{M}_r + j\underline{M}_i \quad (27c)$$

$$= (\underline{a}_r \underline{b}_r^T - \underline{a}_i \underline{b}_i^T) + j (\underline{a}_i \underline{b}_r^T + \underline{a}_r \underline{b}_i^T)$$

where  $\underline{a}_r$  and  $\underline{a}_i$  are respectively the real and complex components and  $j=\sqrt{-1}$ . To perform the outer product in an acousto-optic processor requires positive real quantities. Let us add bias vectors  $\hat{\underline{a}}$  and  $\hat{\underline{b}}$  to vectors  $\underline{a}$  and  $\underline{b}$ , respectively. Thus the outer product of biased vectors becomes

$$\begin{aligned} & \begin{bmatrix} \underline{a}_r + \hat{\underline{a}} \\ \underline{a}_i + \hat{\underline{a}} \end{bmatrix} \begin{bmatrix} (\underline{b}_r^T + \hat{\underline{b}}^T) & (\underline{b}_i^T + \hat{\underline{b}}^T) \end{bmatrix} \\ = & \begin{bmatrix} (\underline{a}_r \underline{b}_r^T + \underline{a}_r \hat{\underline{b}}^T + \hat{\underline{a}} \underline{b}_r^T + \hat{\underline{a}} \hat{\underline{b}}^T) & (\underline{a}_r \underline{b}_i^T + \underline{a}_r \hat{\underline{b}}^T + \hat{\underline{a}} \underline{b}_i^T + \hat{\underline{a}} \hat{\underline{b}}^T) \\ (\underline{a}_i \underline{b}_r^T + \underline{a}_i \hat{\underline{b}}^T + \hat{\underline{a}} \underline{b}_r^T + \hat{\underline{a}} \hat{\underline{b}}^T) & (\underline{a}_i \underline{b}_i^T + \underline{a}_i \hat{\underline{b}}^T + \hat{\underline{a}} \underline{b}_i^T + \hat{\underline{a}} \hat{\underline{b}}^T) \end{bmatrix} \quad (28) \end{aligned}$$

To obtain the desired  $\underline{M}$  of (27c), appropriate quantities are subtracted from (28).

### C. Accuracy

Computational accuracy in optical processing system is of concern. Standard acousto-optical processing procedures is limited to an accuracy of 8-10 bits. Recently, techniques for improving accuracies in optical computing have been presented by Athale et al [17]. In this technique, elements of matrices are represented in binary form and binary multiplication via outer product is combined with the outer product decomposition of matrix multiplication to create high accuracy optical matrix multipliers. To multiply two  $N \times N$  matrices, each with  $m$ -bit dynamic

range would require an optical system with an  $mN \times mN$  space-bandwidth product capability and a dynamic range of  $\log_2(mN)$  bits [17].

## V. SUMMARY AND DISCUSSIONS

We have presented an outer product, matrix-matrix multiplier iterative optical processor (OIOP) which can be used to solve the matrix equation  $P=WS^{-1}$  iteratively without having to invert  $S$  in which  $S$  and  $W$  are known matrices. The OIOP can be used to solve the continuous time dependent Riccati equation that arise in Kalman filtering problems in which the coefficient matrices (i.e.,  $F$ ,  $G$ ,  $H$  and  $R$ ) are constants or piecewise constants. A functional design of the OIOP system requires a matrix-matrix outer product multiplier, electronic summing circuitry, a comparator circuitry, and a feedback loop. The iterative algorithm can also, of course, be implemented digitally.

We have also briefly discussed methods of handling bipolar or complex data in the OIOP, as these optical processors must deal with non-negative real data. The question of computational accuracy in matrix-matrix multiplication was not addressed in detail; however, the technique of binary representation using outer product decomposition [17] provide a method to obtain high accuracy at the expense of losing some of processor space-bandwidth product.

## VI. ACKNOWLEDGEMENTS

The author wishes to acknowledge the interesting discussions with W. Collins on the outer product multiplier and R. Lindberg on the application of continuous Riccati equation. Thanks are extended to Jan Latimer for her patience and skill in typing several revisions of this report.

## VII. LIST OF REFERENCES

1. H. L. Van Tress, Detection, Estimation, and Modulation Theory, Part I, John Wiley and Sons, Inc., New York, pp 538-546, 1968
2. A. P. Sage and C. C. White, III, Optimum Systems Control, Prentice-Hall, Inc., Englewood Cliffs, New Jersey, pp 89, 1977
3. A. Gelb, Editor, Applied Optimal Estimation, the M.I.T. Press, p.122, 1974
4. T. Pappas, and A. J. Lamb, on the solution of the discrete-time algebraic riccati equation, IEEE Trans on Automatic Control, Vol. AC-25, no.4, pp 631-641, Aug 1980
5. A. L. Laub, A schur method for solving algebraic riccati equations, IEEE Trans on Automatic Control, Vol. AC-24, no.6, pp 913-921, Dec 1979
6. R. A. Heinz et al., matrix multiplication by optical means, Applied Optics, Vol. 9, no. 9, pp 2161-2168, September 1970
7. R. P. Bocker, matrix multiplication using incoherent optical techniques, Applied Optics, Vol.13, no.7, pp.1670-1676, July 1974
8. D. Psaltis, D. Casasent and M. Carlotto, iterative color-multiplexed, electro-optical processor, Optic Letters, Vol. 4, No. 11, November 1979, p.548.
9. M. Tur, J. W. Goodman, B. Moslehi, J. E. Bowers and H. J. Shaw, fiber-optical signal processor with applications to matrix-vector multiplication and lattice filtering, Optics Letters, Vol. 7, No. 9, September 1982, p.463.

10. H. J. Caulfield, L. Dvornik, J. W. Goodman and W. Rhodes, eigenvector determination by noncoherent optical methods, Applied Optics, Vol. 20, No. 13, 1 July 1981, p.2263.
11. B.V.K. Vijaya Kumar and D. Casasent, eigenvector determination by iterative optical methods, Applied Optics, Vol. 20, No. 21, 1 November 1981, p.3707.
12. D. Casasent, C. Neuman and M. Carlotto, electro-optical processor for optimal control, SPIE, Vol. 295, Control and Communication Technology in Laser Systems, 1981, p.176.
13. D. Casasent, J. Jackson and C. Neuman, frequency-multiplexed and pipelined iterative optical systolic array processor, Applied Optics, Vol. 22, No. 1, 1 January, 1983, p.115.
14. R.H. Athale and W.C. Collins, "Optical matrix-matrix multiplier based on outer product decomposition," Applied Optics, 21 (1982) p.2089.
15. A. Tarasevitch, N. Zelkin, and W. T. Rhodes, "Matrix-vector multiplier with time-varying single-dimension spatial light modulators," In Optical Information Processing for Aerospace Applications, NASA Conference Publication No. 2207 (1981).
16. R. T. Rhodes, Acousto-optic matrix vector and matrix-matrix multiplications, La Jolla Workshop, March 1982.
17. R.A. Athale, W.C. Collins and P.D. Stilwell, "High accuracy matrix multiplication with outer product optical processor," Applied Optics, Vol. 22, No. 3, 1 February 1983.

END

DATE  
FILMED

9-83

DTI