

High-stability coaxial flashlamp-pumped dye laser

T. B. Lucatorto, T. J. McIlrath, S. Mayo, and H. W. Furumoto

DTIC FILE COPY
AUG 5 1983
A

Measurements on the stability of a coaxial flashlamp-pumped dye laser demonstrated that the quality of the output can be dramatically improved by isolating the dye cell thermally from the flashlamp and ensuring uniform axially symmetric flow of the dye throughout the cell. A quadraxial laser tube in which the dye cell is surrounded by an evacuated annulus to provide thermal isolation and is terminated by specially designed end caps to provide uniform injection and removal of the dye solution was tested in a standard cavity with a 1200-line/mm grating in Littrow configuration as the dispersive element. The performance characteristics were 1-mrad divergence, 0.5-Å bandwidth of the spectral distribution, and 0.04-Å jitter of wavelength at maximum intensity.

I. Introduction

The coaxial flashlamp configuration for use in pumping a dye laser has several important advantages over linear lamp systems. The most important is that this configuration permits the flashtube to be part of an electrical circuit, which has the lowest possible inductance for a lamp with a given energy output. Thus coaxial flashtubes have faster rise times and higher peak current densities. This means they can produce plasmas with higher effective temperatures. The shorter rise time of the coaxial systems is especially important in pumping dyes in which triplet quenching is a problem; the higher temperatures result in more effective pumping of the blue dyes and higher peak output power for a given volume of dye.

Another advantage of coaxial flashlamps as compared to the linear versions is that, for a given length, a greater surface area of emitting plasma can be efficiently coupled to the dye. Thus, for a given length, a greater volume of dye may be efficiently pumped, making possible lasers with larger beam cross sections and greater total energy.

The tunable high-energy output attainable with these lasers has made them extremely useful in photochemistry,¹ lidar,² resonance ionization spectroscopy,³ and experiments involving resonant laser-vapor interactions.⁴ The achievement of good beam quality and a narrow bandwidth spectral distribution with pulse-to-pulse stability of center wavelength and energy has been difficult with these lasers, however, primarily because of thermal effects in the dye cell.

These thermal effects arise from two sources: (1) the

pulsed heating of the dye solution by the radiation absorbed from the flash; (2) the relatively slow heat transfer from the varying thermal gradients in the surroundings of the dye cell and the dye-handling system.

The first type of heating imposes a fundamental limit on the beam quality and spectral purity of a laser and is characteristic of all flashlamp-pumped lasers, including ruby and YAG systems. In solid-state systems the heating can be made cylindrically symmetrical and monotonic in such a way as to allow the maintenance of high quality modes in spite of the changes in cavity parameters during the pulse. In dye lasers, however, the gradients are not smooth or monotonic⁵ so that the high pump energy from the flashlamp can create problems with beam divergence (and spatial inhomogeneities) and spectral broadening when the dye cell is used within the laser cavity. This problem may be minimized by wavelength shifting and filtering of the pump light to match the relevant absorption of the dye⁵ and may be circumvented by removing the dye cell from the laser cavity as in an oscillator-amplifier system.⁶ It is also possible to obtain high spectral purity in a high-energy flashlamp-pumped system by injection locking⁷ and by using an unstable resonator cavity.⁸

The second source of thermal effects can be especially troublesome with coaxial configuration because the flashtube, which is a source of considerable heat, surrounds the dye cell in close proximity. In the past, two means of providing thermal isolation of the dye cell have been used: (1) the so-called triaxial arrangement in which a coaxial water jacket separates the dye cell from the flashlamp, with both the dye and water temperature stringently controlled²; (2) a quadraxial arrangement in which a coaxial jacket of flowing nitrogen is added to the triaxial design between the water jacket and the dye cell to reduce the stringency of the temperature control required.⁹ Both these solutions were designed to allow high repetition rates (which cause considerable heating of the flashtube) while still maintaining good beam quality with high focusable energy. We developed and

Thomas McIlrath is with University of Maryland, Institute for Physical Science & Technology, College Park, Maryland 20742; H. W. Furumoto is with Candela Corporation, Natick, Massachusetts 01760; the other authors are with U.S. National Bureau of Standards, Washington, D.C. 20234.

Received 25 February 1980.

ADA131157

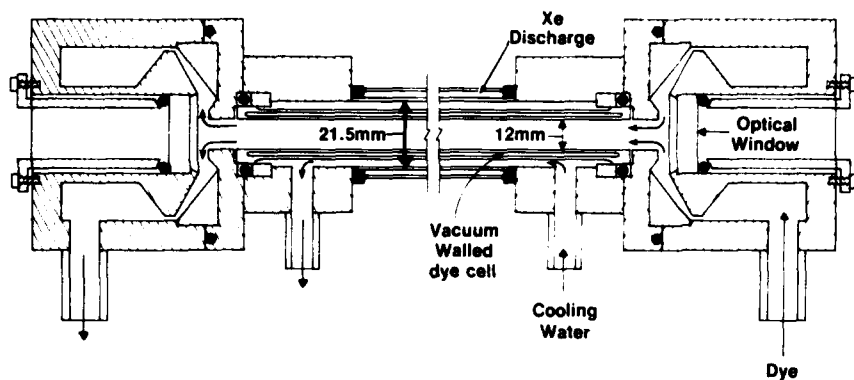

Fig. 1. Flashlamp quadraxial arrangement showing the end cap design.

tested an improved version of the quadraxial design in which an evacuated annulus was used in place of the flowing nitrogen annulus, and a new end cap design was used to provide symmetric uniform injection and removal of the dye solution. This design provides excellent beam quality and wavelength stability and completely eliminates the need for temperature control.

II. Experimental Setup

Three different laser configurations were tested: (1) simple coaxial, with the dye cell being bounded by the quartz inside wall of the flashtube; (2) triaxial, with the dye cell and surrounding concentric water jacket (made of borosilicate glass) each being temperature controlled to $>0.05^\circ\text{C}$; (3) quadraxial, with the dye cell separated from the water jacket by a concentric evacuated annulus (of borosilicate glass) extending the whole length of the laser tube (Fig. 1). In the coaxial and triaxial configurations the dye inlet and outlet were simple 8-mm i.d. holes bored perpendicular to the laser axis, one at each end of the dye cell. In the quadraxial arrangement we tested both the simple hole inlet and outlet and the specially designed set of end caps. The laser cavity for all the tests consisted of a 40% reflectivity output mirror and a 1200-line/mm high damage resistance grating being used in a Littrow-type configuration. The flashtube was driven by a 1.5- μF capacitor charged to 25 kV, and the outputs ranged from 0.5 to >1.2 J with the four dyes used (coumarin 504, rhodamine 560, rhodamine 575, and rhodamine 6G, either in methyl or ethyl alcohol).

The beam divergence of the laser in the various configurations was determined by measuring the aperture that would allow 80% energy transmission at the focal point of a 1-m lens. The spectral distribution of the radiation was measured using a specially designed modified Ebert-type spectrometer with a 1024-element linear diode array at the focal plane; the instrument had a resolution of ~ 0.07 Å in our wavelength region.¹⁰

III. Measurements and Observations

A. Coaxial System

The image of a He-Ne alignment laser beam directed along the axis of the cavity by a beam splitter and re-

flected back on itself by the output mirror (thereby passing through the dye cell twice) was used to monitor the optical distortion in the cell. As is well known, enormous distortion is observed directly after the laser pulse. In our system the pulse-induced distortion decayed in ~ 15 sec when the dye flow rate was $150\text{ cm}^3/\text{sec}$. After this time the optical distortion reached a steady-state level of fluctuation, which was characterized by a slight flickering motion of the reflected beam of $\sim 10\%$ of the beam diameter. This fluctuation was probably due to small random pressure fluctuations in the dye solution and thermal gradients in the environment of the laser tube and in the dye solution, and the level seemed independent of dye flow rate from 20 to $200\text{ cm}^2/\text{sec}$.

Measurements of the beam divergence of the dye laser output and the spectral distribution were made at repetition rates of $1/20$ – $1/60$ Hz. Optimum operation occurred for rates of $1/30$ Hz or less and was characterized by a beam divergence of ~ 4 mrad and a bandwidth of ~ 5 Å and an rms pulse-to-pulse variation of center wavelength of ~ 1 Å. The pulse-to-pulse energy variation was $\sim 10\%$.

B. Triaxial System

The He-Ne laser was used as in Sec. III.A to observe the steady-state fluctuations in the optical distortion. It was found that the reflected He-Ne beam could be made motionless if the water jacket was maintained several tenths of a celsius cooler than the dye cell with the temperature difference held to within $\pm 0.05^\circ\text{C}$ of the optimum value. We did not ascertain whether this temperature difference compensated for some thermal inhomogeneity elsewhere in the system or was related to another effect, but the exact value of the optimum temperature difference did differ somewhat when another triaxial tube was used with a different dye circulator system. The results were quite striking: the beam divergence was reduced to 1 mrad, the bandwidth to 0.5 Å, and the pulse-to-pulse wavelength fluctuation to <0.1 Å if and only if the temperature differential was within 0.05°C of the optimum value. When the temperature differential deviated $>0.05^\circ\text{C}$ from the proper value, the behavior of the laser deteriorated rapidly, quickly becoming comparable to or worse than the straight coaxial system.

C. Quadraaxial System

The tests described in Secs. III. A and B. showed that the optical quality of the dye cell was extremely sensitive to temperature inhomogeneities and that only by applying very stringent temperature control to anything in thermal contact with the cell could the thermal effects be made negligible. To eliminate the difficulties encountered in maintaining such fine temperature control, we designed a system in which the dye cell was separated from its surroundings by an evacuated space. Also to reduce the effects of pressure fluctuations, pressure gradients, and thermal gradients created in the dye solution as it flowed through the system, we employed the end caps shown in Fig. 1, which were designed to direct the fluid in a smooth axially symmetric manner and to minimize any stagnation in the cell. The axial symmetry ensures that pressure and thermal gradients will be minimized in the direction perpendicular to the tube axis.

Again the He-Ne laser was used to observe the steady-state optical distortion. Absolutely no fluctuations in the image of the reflected beam were observable by eye. The beam divergence and stability of the spectral distribution of the laser output were as good as with the temperature controlled triaxial tube, i.e., the beam divergence was 1 mrad, the bandwidth was 0.5 Å, and the center wavelength had a barely detectable shot-to-shot variation (estimated at 0.04 Å). Figure 2 shows three traces of the spectral distribution for three successive laser firings. In addition to the spectral stability we observed that the shot-to-shot variation in output energy is $\pm 5\%$.

These results were obtained at the maximum capacitor energy loading of 450 J, at flow rates between 150 and 1000 cm³/sec, at repetition rates up to 0.5 Hz (with the fastest flow rate), and with temperature differences between the dye and the cooling water as great as 3°C. As a test the specially designed end caps were replaced with the simpler side bore types used in Secs. III. A and B. To obtain a better quantitative measure of the wave front distortion in the dye medium, the dye cell was put into an interferometer cavity that utilized

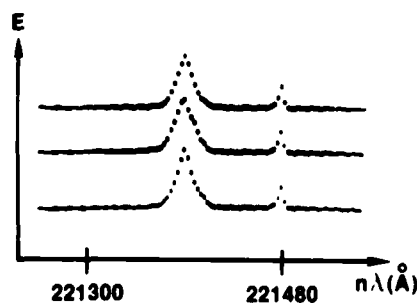

Fig. 2. Spectral distribution of three sequential laser pulses taken with the instrument described in Ref. 10. Each dot represents a channel of width $n\lambda = 2.8$ Å. To the right at $n\lambda = 221480$ Å is a He-Ne laser reference marker in 35th order. The pulsed laser is tuned to $\lambda = 5534.8$ Å and appears in 40th order at $n\lambda = 221393$ Å. For the pulsed laser each dot represents 0.07 Å. It is estimated that the center wavelength of the distribution varies about $\frac{1}{2}$ of a channel.

a beam-expanded He-Ne laser as the source. When the simple side bore end caps were used, fluctuations by two fringes were observed in the interference pattern. This compares with fluctuations of about one-tenth of a fringe obtained with the special end caps. This demonstrates that the side bore inlet and outlet make the dye cell much more sensitive to dye pump pressure fluctuations and dye solution temperature inhomogeneities than the axially symmetric system.

The addition of a Fabry-Perot plate with a 2.5-Å free spectral range and a finesse of 10 resulted in a bandwidth that was <0.1 Å, the resolution of our spectrum analyzer, with only a 20% decrease in energy. It is expected that because the resonant wavelength of the Fabry-Perot plate is 3 orders of magnitude less sensitive to variations in the angle of incidence than the grating, the stability of the output wavelength will be similarly increased.

IV. Summary

It is shown that the addition of an insulating jacket between the dye solution and the flashlamp cooling water in a coaxial dye laser provides an increase in beam quality and stability that is as good or better than that obtained by precision temperature control of the cooling water in a triaxial system. The resultant ability to operate without any unusual temperature controlling devices greatly simplifies the operation of coaxial dye lasers and significantly increases the useful repetition rate. Beam divergences of 1 mrad and wavelength stabilities of >0.1 Å result from operation in a standard cavity.

We wish to thank J. E. Rives, Otis Peterson, and D. Horowitz for providing helpful information and D. C. Morgan for his aid in designing and machining the end caps. The work done at the National Bureau of Standards was partially supported by the Office of Naval Research, contract 00014-79-F-0051. Thomas McIlrath also holds an appointment with the National Bureau of Standards.

References

1. S. Janes, H. Forsen, and R. Levy, "Research and Development Prospects for Atomic Uranium Laser Isotope Separation Process," Am. Inst. Chem. Eng. Symposium Ser. 169 73, 62 (1976); V. S. Letokhov, "Future Applications of Selective Laser Photochemistry and Photochemistry," in *Tunable Lasers and Applications*, A. Mooradian, T. Jaeger, and P. Stokseth, Eds. (Springer, New York, 1976).
2. R. M. Schotland, *Appl. Opt.* **19**, 124 (1980).
3. G. S. Hurst, M. H. Nayfeh, and J. P. Young, *Phys. Rev. A*: **15**, 2283 (1977).
4. T. J. McIlrath and T. B. Lucatorto, *Phys. Rev. Lett.* **38**, 1390 (1977).
5. K. L. Matheson and J. M. Thorne, *Appl. Phys. Lett.* **35**, 314 (1979).
6. J. L. Carson and T. J. McIlrath, *Opt. Commun.* **8**, 52 (1973).
7. T. Okada, M. Maeda, and Y. Miyazoe, *IEEE J. Quantum Electron.* **QE-15**, 616 (1979).
8. T. F. Ewanisky, *Appl. Phys. Lett.* **25**, 295 (1974).
9. L. A. Godfrey, R. S. Meltzer, and J. E. Rives, *Appl. Opt.* **18**, 602 (1979).
10. M. B. Morris and T. J. McIlrath, *Appl. Opt.* **18**, 4145 (1979).



A 21