

MICROCOPY RESOLUTION TEST CHART
NATIONAL BUREAU OF STANDARDS-1963-A

AFOSR-TR- 83-0644



OPTICAL SYSTEMS and STATISTICAL OPTICS

Dr. Nicholas George
Principal Investigator
The Institute of Optics
University of Rochester
Rochester, New York 14627

ADA 131297

Annual Report to AFOSR on
Contract No. AFOSR-77-3434

Prepared for

Electronic and Material Sciences
Air Force Office of Scientific Research (AFOSR)
Bolling Air Force Base, D.C. 20332
Attention: Lt. Col. Harry V. Winsor

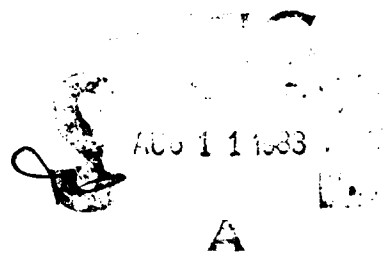

May 1983

Approved for public release
distribution unlimited.

DTIC FILE COPY

88 08 08 183

REPORT UNCLASSIFIED		READ INSTRUCTIONS BEFORE COMPLETING FORM	
1. REPORT NUMBER AFOSR-TR- 83-0644	2. GOVT ACCESSION NO.	3. RECIPIENT'S CATALOG NUMBER	
4. TITLE (and Subtitle) Optical Systems and Statistical Optics		5. TYPE OF REPORT & PERIOD COVERED Annual Technical Report 1 Oct 1981 - 1 Mar 1983	
7. AUTHOR(s) Nicholas George Principal Investigator		6. PERFORMING ORG. REPORT NUMBER	
9. PERFORMING ORGANIZATION NAME AND ADDRESS The Institute of Optics University of Rochester Rochester, New York 14627		8. CONTRACT OR GRANT NUMBER(s) AFOSR-77-3434	
11. CONTROLLING OFFICE NAME AND ADDRESS Air Force Office of Scientific Research Building 410 Bldg 410 AFOSR C. 2033.2		10. PROGRAM ELEMENT, PROJECT, TASK AREA & WORK UNIT NUMBERS 6110 2F 2305/1B1	
14. MONITORING AGENCY NAME & ADDRESS (if different from Controlling Office)		12. REPORT DATE May 1983	
		13. NUMBER OF PAGES 51	
		15. SECURITY CLASS. (of this report) Unclassified	
		15a. DECLASSIFICATION/DOWNGRADING SCHEDULE	
16. DISTRIBUTION STATEMENT (of this report)			

Approved for public release;
distribution unlimited.

17. DISTRIBUTION STATEMENT (of the abstract entered in Block 20, if different from Report) Unlimited
18. SUPPLEMENTARY NOTES
19. KEY WORDS (Continue on reverse side if necessary and identify by block number) White light processing; pattern recognition; image evaluation; wideband, achromatic Fourier transform; scattering, dielectric cylinders, conducting cylinders; holographic optical elements; metrology; speckle.
20. ABSTRACT (Continue on reverse side if necessary and identify by block number) Theoretical and experimental research is being conducted in the field of opto-electronic systems. The goal is to contribute solutions to problems of basic research importance which also have an underlying significance in practical applications that involve automatic pattern recognition and remote sensing. White light processing systems are described both for matched filtering and for diffraction pattern sampling. Also excellent progress is reported on our related studies of broadband holographic optical (over)

DD FORM 1 JAN 73 1473

Unclassified
SECURITY CLASSIFICATION OF THIS PAGE (When Data Entered)

UNCLASSIFIED

20. Abstract--continued

elements and an off-axis Fourier transform achromat. With coherent illumination we report a means for automatic image quality evaluation. The scattering of light by dielectric and conducting cylinders has been studied theoretically and experimentally with an emphasis on remote optical metrology.

A



UNCLASSIFIED

OPTICAL SYSTEMS and STATISTICAL OPTICS

Nicholas George
Principal Investigator

ABSTRACT

Theoretical and experimental research is being conducted in the field of opto-electronic systems. The goal is to contribute solutions to problems of basic research importance which also have an underlying significance in practical applications that involve automatic pattern recognition and remote sensing. White light processing systems are described both for matched filtering and for diffraction pattern sampling. Also excellent progress is reported on our related studies of broadband holographic optical elements and an off-axis Fourier transform achromat. With coherent illumination we report a means for automatic image quality evaluation. The scattering of light by dielectric and conducting cylinders has been studied theoretically and experimentally with an emphasis on remote optical metrology.

AIR FORCE OFFICE OF SCIENTIFIC RESEARCH (AFOSR)
NOTICE OF TRANSMITTAL TO DTIC
This technical report has been reviewed and is
approved for public release IAA AFOSR 19-1-12.
Distribution is unlimited.
MATTHEW J. KERPER
Chief, Technical Information Division

OPTICAL SYSTEMS and STATISTICAL OPTICS

TABLE OF CONTENTS

	Page
1. INTRODUCTION	3
2. TECHNICAL PROGRAM	3
2.1 Image Recognition	6
2.1.1 Matched Filtering in White Light Illumination	11
2.1.2 Diffraction Pattern Sampling in White Light	13
2.2 Holographic Optical Elements	18
2.3 Scattering of Light from Large Cylinders	24
2.4 Scattering by Elliptical Apertures	33
2.5 Image Understanding and Evaluation	39
2.6 Computer Generated Objects	41
3. LISTS OF PUBLICATIONS AND ABSTRACTS	44
4. PERSONNEL AND RELATED SUPPORT	48

OPTICAL SYSTEMS and STATISTICAL OPTICS

1.0 INTRODUCTION

In this annual report, brief descriptions are made of major results obtained on our program of research on "Optical Systems and Statistical Optics" which is sponsored by the Air Force Office of Scientific Research. Publications resulting from this research are also cited (see Section 3 for cumulative listing), and the Abstracts are contained in the text of this report as part of the technical discussion. The period covered by this report is approximately 18 months from 1 October 1981 to 1 March 1983.

This report also contains a description of personnel in Sec. 3.0. Also two new laboratories have been added--one for research on diffraction pattern sampling, and one for research on hologram optics.

2.0 TECHNICAL PROGRAM

The field of Holography and Optical Information Processing is an important and active one with many significant advances during the past twenty years. A family tree showing only the major interrelations is shown in Fig. 1. This field is one with intense research activity at many universities, complemented by device research and high technology activities in industrial laboratories. Early work in holography and processors for synthetic aperture radars led to many important advances, labeled as major innovations, and active research programs in image

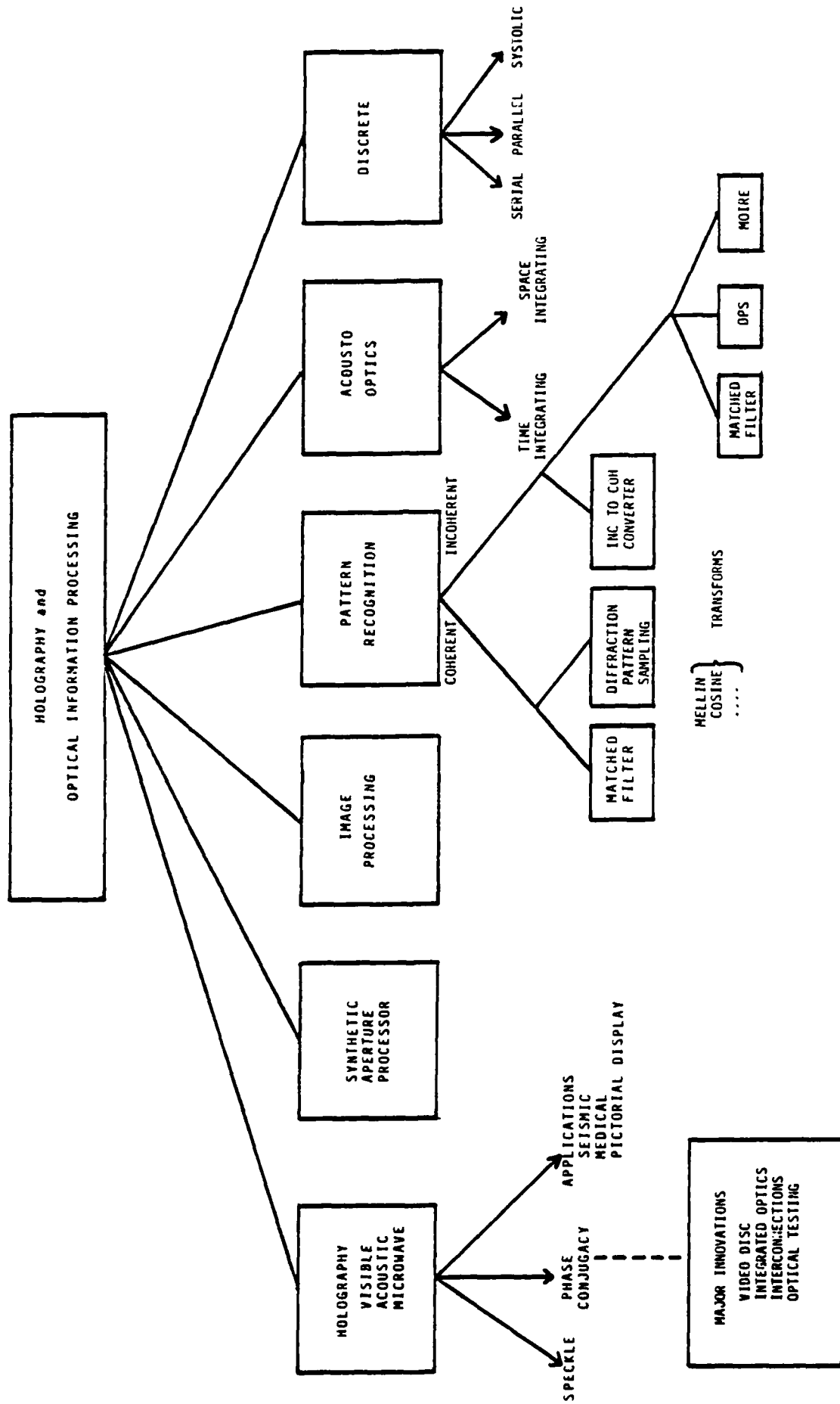

Fig. 1. Family Tree of Holography and Optical Information Processing. Many of the major developments in this field have occurred since the early sixties.

processing, pattern recognition, acousto-optics and discrete processors.

In the research described in this progress report, effort is centered on automatic pattern recognition using either coherent or incoherent illumination and on selected topics in image processing or image understanding (see Fig. 1). Related research of a basic nature in speckle or optical noise is also reported. While these problems about noise and the limits of resolution typically arise from our studies of various opto-electronic systems, it is appropriate to separate them somewhat so that they can be studied in a more abstract and basic manner. Hence, our long-term goal is to contribute solutions to problems having basic research importance which have as well an underlying significance in the practical applications of lasers and optics. Two relevant themes underlie our interest in the research being pursued. These are:

- Robot vision systems using hybrid optics
- Noise limitations in remote optical sensors.

In the following sections there are descriptions of several research topics:

- 2.1 Image Recognition
 - 2.1.1 Matched Filtering in White Light Illumination
 - 2.1.2 Diffraction Pattern Sampling in White Light
- 2.2 Holographic Optical Elements
- 2.3 Scattering of Light from Large Cylinders
- 2.4 Scattering by Elliptical Apertures
- 2.5 Image Understanding and Evaluation
- 2.6 Computer Generated Objects

2.1 Image Recognition*

Suppose that we have some imagery which we wish to recognize automatically or in an operator-independent fashion. This is a general problem in robot vision. Approaches to this general problem in pattern recognition can be classified according to the tree structure shown in Fig. 2. One can choose a direct computer method in which the input object is imaged via a detector array into a digital computer or alternatively one may elect a transform method. Since the type of equipment varies greatly with these two approaches, it is helpful at the outset to decide which is more appropriate. This matter has been studied by us and by others in prior years, and it is generally agreed that the domain which permits one to sample coarsely and still to make recognition decisions to an acceptable accuracy is the more appropriate. For example, in facial recognition a coarse sampling of the direct image, say with 200 pixels, is adequate. Thus, direct processing of a sampled image using a digital computer is a reasonable approach.

Alternatively, the optical transform method is preferable when imagery of larger space-bandwidth and high frame rate needs to be sorted. Aerial reconnaissance photographs are representative of this case, particularly when one wants to make a simple assessment such as to count numbers of vehicles in a complex frame or

* This introductory material is revised from the annual report for the period October 1980 to October 1981 on Contract No. AFOSR-77-3434 by Nicholas George.

AUTOMATIC PATTERN RECOGNITION

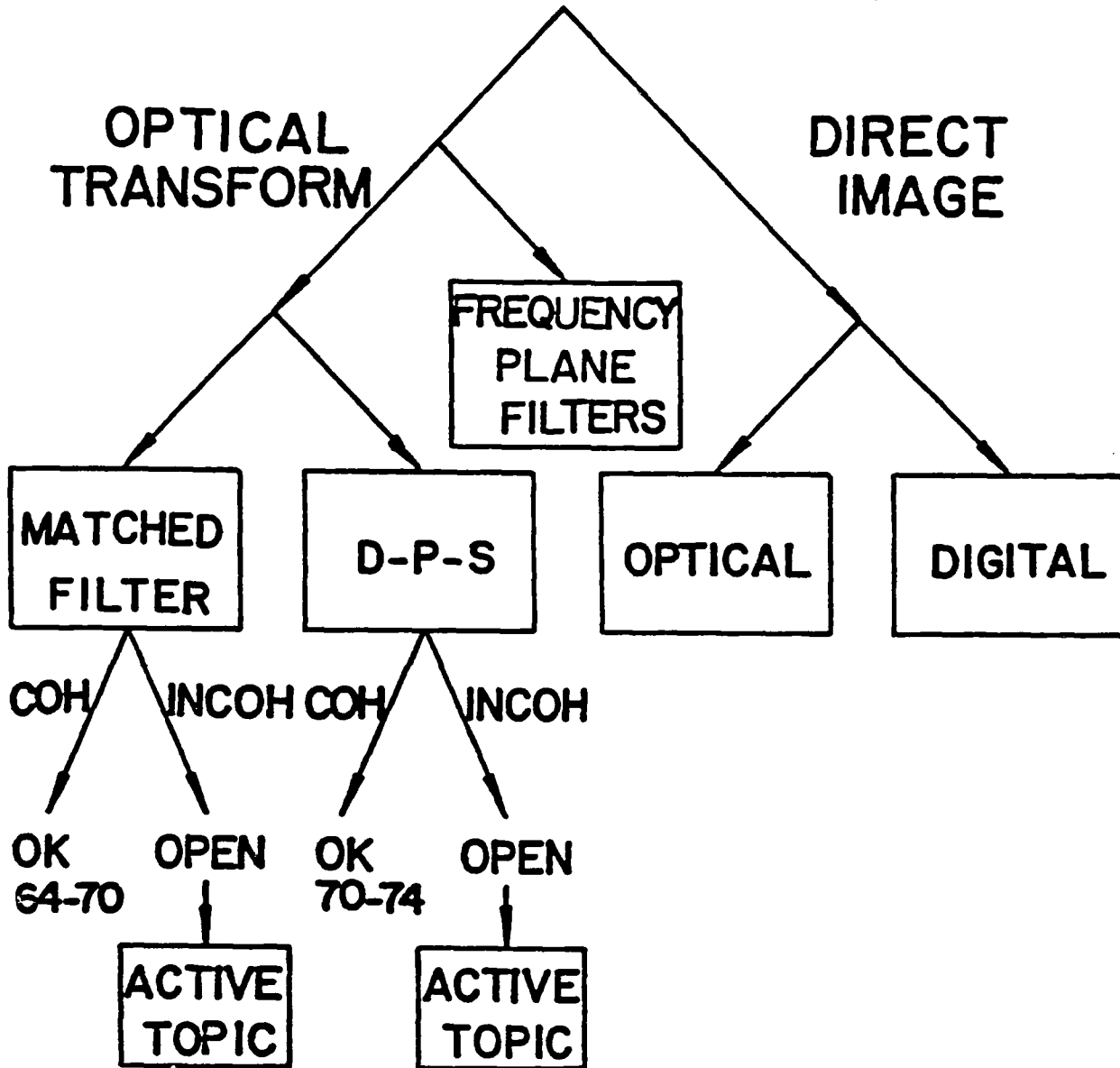

Fig. 2 Family tree showing main approaches in automatic pattern recognition: direct image processing or optical transform methods. Optical transform methods are advantageous when the frame rate and the space-bandwidth product of a frame are very large. With noncoherent illumination, both matched filtering and diffraction-pattern-sampling pose significant problems of current research interest.

to decide in an operator-independent manner whether or not a frame is cloud-obscured. Likewise automatic quality assessment, largely independent of scene content, is probably best accomplished using an optical transform method.

In our research we are particularly interested in pattern recognition when large numbers of pixels are involved, hence in the optical transform approach. It is important to state this qualification explicitly. Then in reviewing our study of optical transform systems, one can readily understand our emphasis on systems that will work to diffraction limits. Inherently these will be capable of working with high resolution imagery or detailed objects. On the other hand, the geometrical optics class of transform devices probably are not suitable for pattern recognition of detailed objects or high resolution imagery.

Let us review optical transform methods. There are the ad-hoc systems of frequency plane filters. Special solutions for specific problems. The phase contrast microscope is a good illustration of this category. Then there is the matched filter approach. For coherent illumination and with optically smooth input formats, this problem was solved with the elegant work of A. Vander Lugt (1964).^{*} Much research effort was expended on this type of system during the period from 1964 to 1970. Now this technique must be viewed as mature and well-understood; so that at this point in time, it is not active as a field of basic research. Hence the labeling "OK."

^{*} Vander Lugt, A.B., "Signal Detection by Complex Spatial Filtering," IEEE Trans. Inform. Th., IT-10, 2 (1964).

For matched filtering in incoherent illumination, Lohmann (1968) and others* made a noteworthy observation that a holographic matched filter in amplitude is also (another) matched filter in intensity. However, practical applications of white light matched filter systems did not materialize, since it was generally thought that the illumination had to be very narrow-band temporally. With hologram systems of that date (1970), this was quite true. In fact many experiments were reported using a laser beam made spatially incoherent by transmission through a rotating ground glass diffuser. Thus, the application of matched filters when the illumination is incoherent is labeled as an open, and important, field meriting current research. As described in Sec. 2.1.1 this has been a topic of major emphasis for the past three years under AFOSR sponsorship.

Before discussing the current research in matched filtering, let me trace the field of diffraction pattern sampling (Sec. 2.1.2). As an alternative to the holographic matched filter, much research effort has been expended on photodiode arrays placed in the optical transform plane. The field of opto-electronic hybrid processors evolved using this configuration. Practical applications

* Lohmann, A., 1968, "Matched filtering with self-luminous objects," *Applied Optics*, 7, 561-563.
 Lohmann, A. & Warlich, U., 1971, "Incoherent matched filtering with Fourier holograms," *Applied Optics*, 10, 670-672.
 Lowenthal, S., & Werts, A., 1968, "Filtrage des frequences spatiales en lumiere incoherente a l'aide d'hologrammes," *Comptes Rendus de l'Academie des Sciences de Paris*, 266, Serie B, 542-545.

of this technique have been made in many fields. A detailed account of this research and the resulting applications would carry me too far afield, and the interested reader is referred to three articles by Thompson.*

However, in diffraction-pattern-sampling too, the successes have been limited to coherent illumination and a smooth input format. A very basic question remains. Namely, how to use diffraction-pattern-sampling when the input object is rough and three-dimensional and the illumination is spatially incoherent. In our family tree, the D-P-S incoherent limb is labeled as "open"--meaning that this is an important area where active research is merited.

Two major goals of our research program sponsored by AFOSR can be stated in the context of Fig. 2. For the past three years we have studied how

- I. To demonstrate achromatized matched filtering of high efficiency using incoherent illumination and rough objects (see Sec. 2.1.1 below); and
- II. To demonstrate diffraction pattern sampling in an opto-electronic hybrid that also uses white light illumination. This latter topic has gained in emphasis during the past year (see Sec. 2.1.2 below).

* Thompson, B.J., "Hybrid Processing Systems--An Assessment," IEEE Proceedings 65, 62-76, 1977; and "Optical Transforms and Coherent Processing Systems--With Insights from Crystallography," Ch. 2, Topics in Applied Optics 23 (Ed. by D. Casasent, Springer-Verlag, Berlin, Heidelberg, New York 1978), pp. 17-52. See also "Current Trends in Optical and Hybrid Processing Methods," in SPIE vol. 388, Advances in Optical Information Processing, pp. 2-8 (1983).

2.1.1 Matched Filtering in White Light Illumination

Matched filtering systems using Fourier-transform achromats have been successfully demonstrated on this program. Several publications resulting from this novel concept for the period (1980-82) have been described in earlier progress reports and are referenced in the cumulative listings in Sec. 3 of this report.

For the current reporting period, a theoretical analysis of the polychromatic speckle in an achromatic transform system was completed by a doctoral scholar Chris Brophy working under the supervision of Dr. G. Michael Morris, Assistant Professor of Optics. This research was published in the Journal of the Optical Society of America, and the Abstract is reproduced in the following paragraph.

J. Opt. Soc. Am. 73, 87-95 (1983):

Speckle in achromatic-Fourier-transform systems
Chris Brophy and G.M. Morris
The Institute of Optics, University of Rochester
Received June 23, 1982

Polychromatic speckle in the output plane of an achromatic Fourier transform system is analyzed. The degree of speckle correlation is calculated and is found to factorize into spectral and spatial parts. Under conditions for sufficiently fine and rough phase modulation of the complex field amplitude in the object plane, the polychromatic intensity in a paraxial region of the transform plane is shown to be spatially wide-sense stationary and approximately ergodic. For normally distributed height statistics, the intensity is approximately spectrally stationary as well. Our calculations indicate that achromatic-transform-plane speckle should be useful for measuring surface roughness and that an achromatic-transform system may be useful in extending the usable stellar bandwidth in stellar speckle interferometry.

Also during the current year, we completed the third generation matched filtering system. It uses an off-axis configuration of Fourier achromat with glass and holographic lenses. Good results were obtained for recognition or correlation of complex objects (engravings of President Hamilton); however, the objects used were illuminated in transmission. The Abstract and a one-paragraph extract from the summary of a lengthy article which was published in an SPIE Proceedings is reproduced below.

SPIE vol. 388 Advances in Optical Information Processing (1983)

Matched filtering in white light illumination
Nicholas George and G.M. Morris
The Institute of Optics, University of Rochester

Abstract

The performance of achromatic optical processors is reviewed and described. Both in-line and off-axis configurations are compared. Matched filtering experiments using a white light source of low spatial coherence are reported. Plots of correlation intensities are presented for the spatially coherent and non-coherent cases.

In the present paper, we review the operation of the matched filter processor describing the chronology of the early systems incorporating first the correction for the wavelength dispersion of the holographic matched filter and secondly the operation of the first-generation Fourier transform achromat. The idealized achromatic optical processor is also reviewed together with the synthesis of broadband Fourier achromats. Then we describe our current off-axis matched filtering processor that incorporates an improved Fourier transform achromat with dichromated-gelatin holographic lenses and gratings. Design and performance details of this configuration are reported. Both laser illumination and white light of low spatial coherence (62 μm to 500 μm) have been used for matched filtering of objects in transmission. The objects themselves have a mild, controlled diffusivity. No experiments are reported for objects viewed in reflection.

This research is continuing. Two major objectives are (1) to obtain correlation or recognition from objects viewed in reflection and (2) to obtain quantitative information on the shape of the correlation intensity that is in accord with theory.

2.1.2 Diffraction Pattern Sampling in White Light

Statement of the Problem and Objectives

Both in pattern recognition and in metrology, optical transforms have proven useful in a variety of applications. Particularly, the optical transform is preferable to processing the image directly whenever the recognition depends on fine scale image features. The reason for this is that it is advantageous to sample the data coarsely, whichever space is involved, before computer processing. This greatly reduces the amount of computer capacity required.

Our objective in this phase of the research is to demonstrate image recognition in white light using a diffraction pattern sampler. We are investigating several configurations for taking the noncoherent optical transform of the object intensity. It should be emphasized that by themselves the achromatized Fourier transform configurations are not appropriate for this when the illumination at the object is spatially incoherent. Having once established an appropriate transform configuration, we will record sampled transform data; and pattern separability will be established using existing pattern recognition software. With a broadband transform and noncoherent illumination, a map-matching system or an automatic vehicle control can be foreseen operating without need for an incoherent-to-coherent converter.

2.1.2-1 Status Report

As described in the proposal for the present report period, several different white light interferometers were studied insofar as their suitability for diffraction-pattern-sampling. A novel configuration using a double-virtual image interferometer followed by a modified all-glass Fourier achromat has been designed, fabricated, and tested. A preliminary report on this interferometer together with a careful review of the literature

have been prepared by a doctoral scholar ShenGe Wang. The Abstract page for this report is reproduced directly below.

Extract from Doctoral Proposal^{*}

Optical Transforms in White Light

ShenGe Wang

Advised by: Dr. Nicholas George

The Institute of Optics, University of Rochester

May 13, 1982

Abstract

Theory and techniques of white light interferometry are being studied in order to develop new methods of optical pattern recognition. In white light illumination or with rough input formats, the conventional diffraction-pattern-sampling system is not applicable without the use of an incoherent-to-coherent converter. As an alternative approach, we are seeking transform systems which can be realized using white light illumination. An objective of this research is to obtain diffraction-limited performance and thereby a large space-bandwidth product. Using a white light interferometer, we can attain a cosine-plus-bias transform. The properties and usefulness of the cosinusoidal transform as applied to diffraction pattern sampling will be studied. Also the inherent noise limitations in the cosinusoidal transform will be established.

A double-imaging interferometer is shown schematically and photographically in Fig. 1. The cube beamsplitter and the pair of roof-prisms were fabricated to interferometric accuracy by a master optician at The Institute of Optics. A low f-number system is realized using this configuration, hence large space bandwidth objects can be imaged. If an optical transform is desired, then the configuration shown in Fig. 2 is found to be the simplest and most effective. An achromatic transform design

* This report (25 p) is available upon written request to the Principal Investigator.

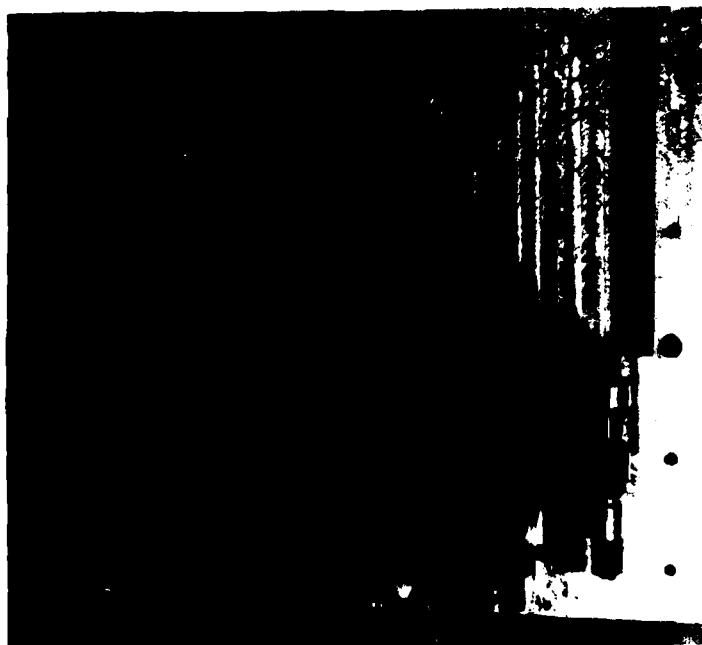
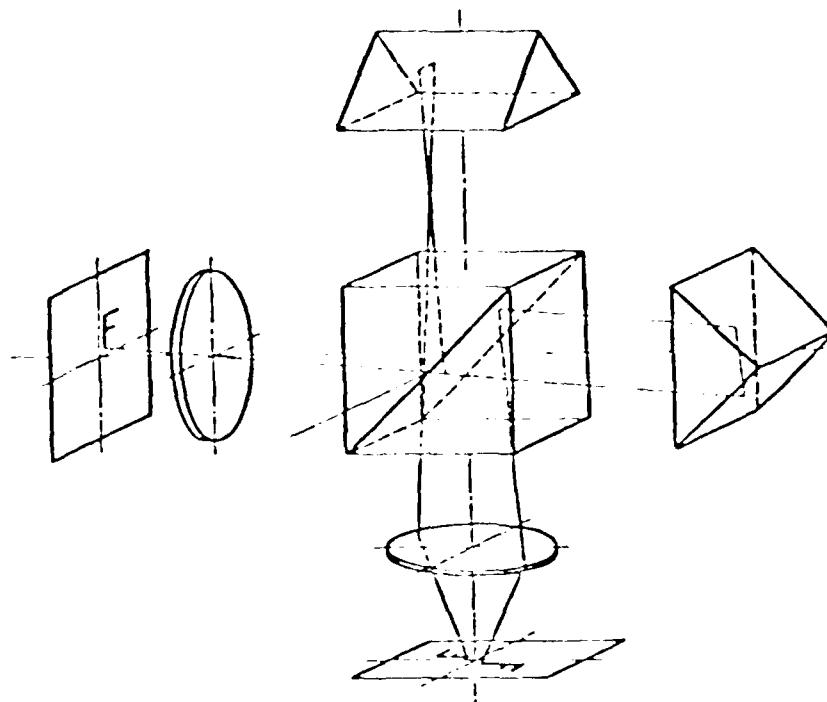

Fig. 1. Double-imaging interferometer with crossed roof-prism reflectors and white-light cube beamsplitter, shown (upper) schematically and (lower) photographically.

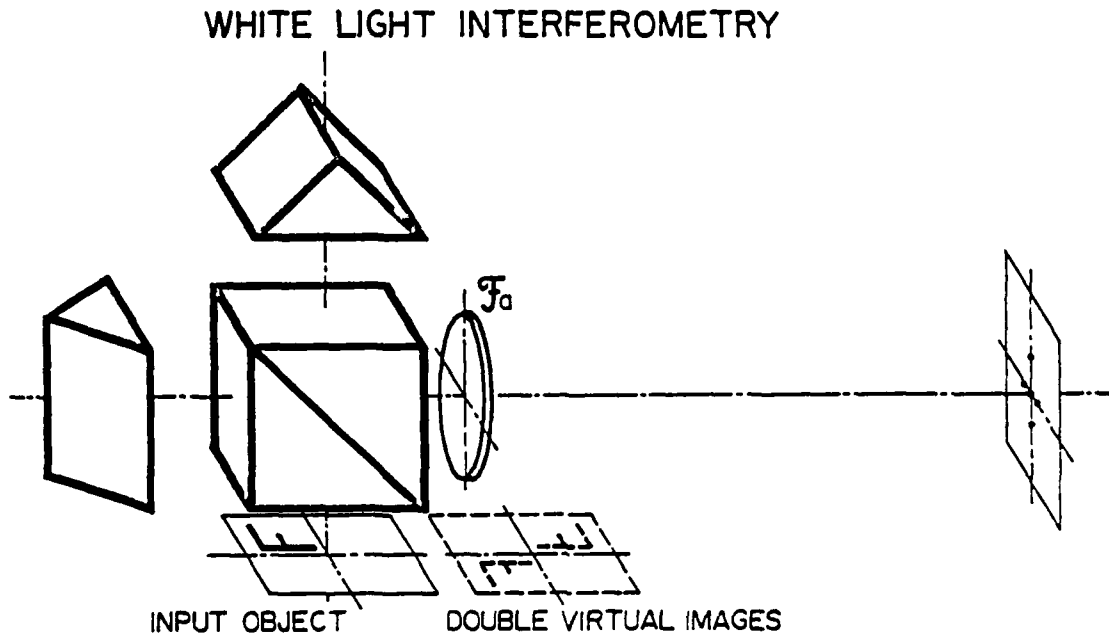

Fig. 2. White light interferometer with a double-virtual imaging system and an improved achromatic transform element \mathcal{F}_a .

(\mathcal{F}_a) is used followed by a screen at which a photodiode array is to be placed. More detailed discussion and some experimental results are being prepared for the 1983 Annual Meeting of the Optical Society of America. This research is continuing.

2.2 Holographic Optical Elements

Accomplishment During the Report Period

Research directed toward extending and improving the existing theory of holographic optical elements has been conducted. Diffraction theory is combined with geometrical optics in the analysis of generalized holographic elements. A theoretical analysis of the cascade design, which consists of a diffraction grating in contact with an off-axis holographic element has been made including broad-spectrum effects. Dialyte configurations of such cascades will be characterized, and extended to hybrid (hologram and lens) cases. Theory is proposed for the analysis of thickness-related aberrations, which are shown to be significant in practical broad-spectrum holographic elements, and may impose resolution limits in such cases. By applying diffraction theory such as the method of thin grating decomposition to the problem of ray transfer through a thick holographic element, an exact holographic raytracing theory is sought. Practical monochromatic and broad-spectrum applications will be considered.

Tremendous progress has been made in a continuing research effort to characterize the achievable bandwidth and volume effects of holographic optical element configurations. The theory of wavelength, volume, and angular sensitivities of holographic optical elements has been studied by two approaches in order to better understand their bandwidth and efficiency. A scatter-based theory is used to analyze the volume holographic grating as a three-dimensional array of dipole scatterers phased by an illuminating wave. In a separate but fundamentally related treatment, a thin grating decomposition theory has been implemented numerically on a digital computer. In this analysis, the thick grating has been decomposed into a cascaded series of thin gratings, each of which is thin enough so as not to exhibit Bragg effects.

Each of these approaches has made a distinct contribution to an understanding of volume holographic elements. The scatter based theory has illustrated the importance and dependence of recording material scattering phenomena to the broad-spectrum characteristics of holographic optical elements. This work was reported in the September 1982 issue of Optics Letters, the abstract of which is reproduced below.

Optics Letters 7, 445-447 (1982):

Bandwidth of holographic optical elements
Thomas Stone and Nicholas George
The Institute of Optics, University of Rochester
Received May 3, 1982

The diffraction efficiency, bandpass, and spurious beam rejection are studied for the holographic cascade lens that consists of a diffraction grating in contact with an off-axis zone plate. An analysis is presented for the bandpass of the volume diffraction grating, including the effects of grain polarizability.

The extensive thin grating decomposition programs, which have been encoded in Fortran IV, have been used to analyze power coupling between the forward-propagating diffracted orders. An important result has been the good correlation between the wavelength dependence of diffraction efficiency calculated by thin grating decomposition and the much simpler analytic array factor. This similarity has initiated an investigation into analytic implementations of the thin grating decomposition theory.

The scattering and decomposition approaches to a detailed understanding of physical holographic elements were chosen because the weaknesses of each theory correspond to the strengths of the other. Work is continuing toward combining these approaches into

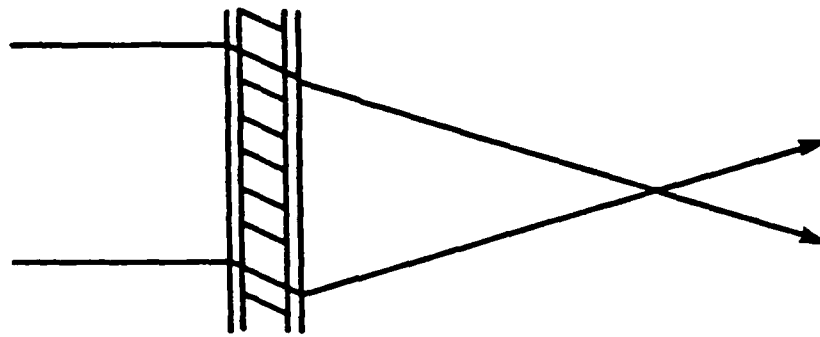

(a)

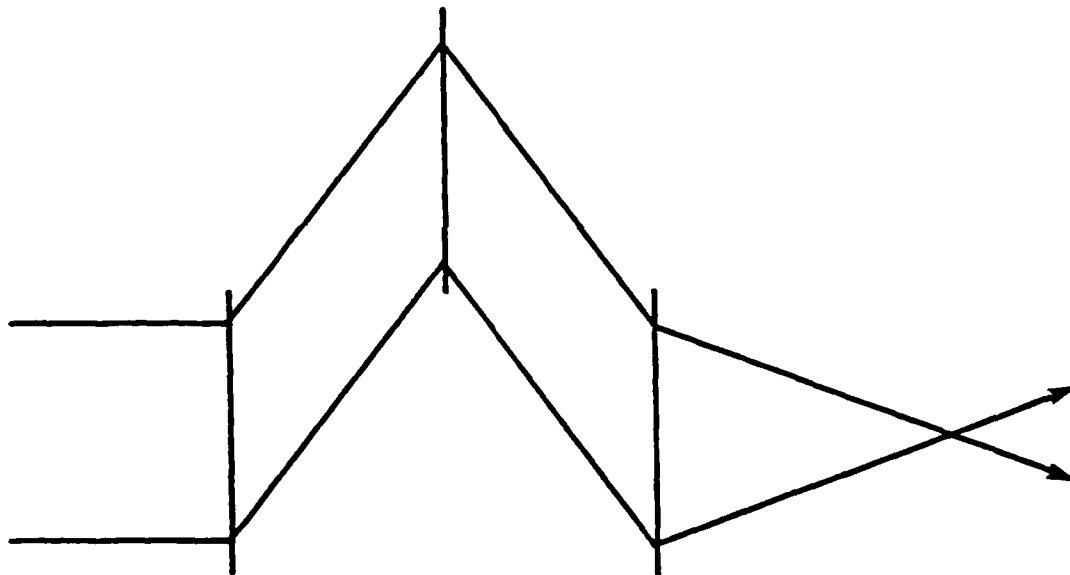

(b)

Fig. 1. Broad-spectrum holographic element configurations:
(a) Close-cascade with venetian blind zero-order block, (b) Ω -configuration.

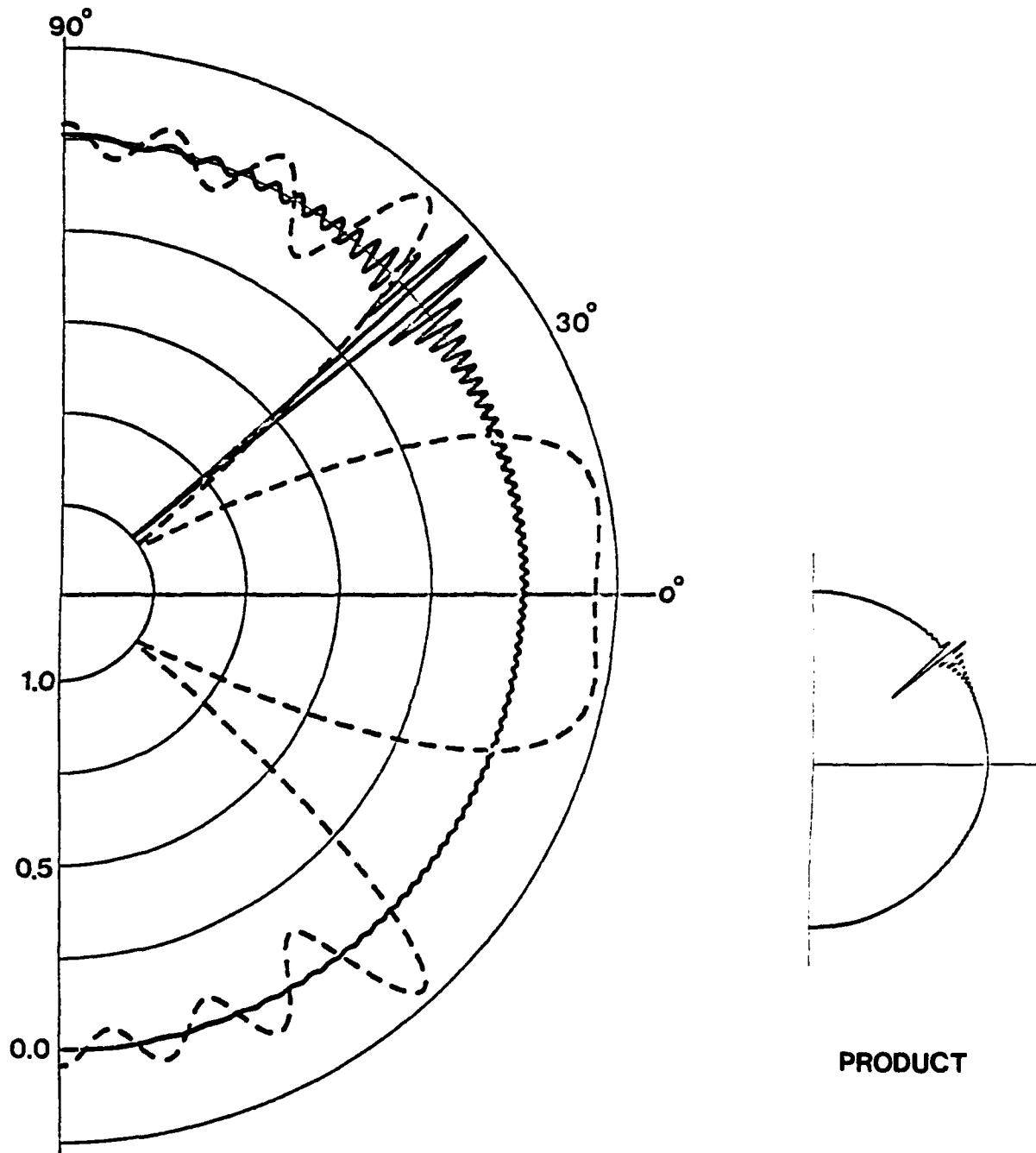

Fig. 2 Diffracted amplitude vs. angle is shown for a normally illuminated hologram. Illumination is at a wavelength 1,900 Å off of center to illustrate the effect of detuning. Diffraction efficiency is proportional to the square of the product of the array factor (dashed line) and the grating factor (solid line).

a unified theory broadly applicable to holographic optical elements.

The previous analyses have been applied to the characterization and fabrication of efficient holographic optical elements for imaging and transforming applications. The close cascade of two off-axis elements, shown in Fig. 1(a), has demonstrated bandwidths in excess of 2000 \AA . The separated cascade "A" configuration, illustrated in Fig. 1(b), has produced bandwidths on the order of 3000 \AA . These elements have been fabricated in silver halide emulsions and in dichromated gelatin, with the peak diffraction efficiencies of the latter material approaching unity.

A doctoral student Thomas W. Stone will be submitting his thesis on this topic during the current contract period, together with one or two papers to Applied Optics. These will complete this phase of our research on holographic optical elements. It is planned to appoint T.W. Stone as a post-doctoral fellow, and he will start some new topic of research on hologram optics. A preliminary abstract of his doctoral thesis follows on the next page.

An important aspect of this thesis is the quantitative description of the wavelength sensitivity of hologram elements. An illustration of the inherently broad-band operation that is possible with holograms is shown in Fig. 2. A thorough exposition of this viewpoint is being prepared for publication in Applied Optics.

Extract from Doctoral Thesis

Holographic Optical Elements
Thomas W. Stone
Advised by Professor Nicholas George

Preliminary Abstract

The fundamental properties of holographic optical elements are analyzed, with particular emphasis placed on their volume related characteristics. Several theoretical approaches are pursued to explain the detailed space, wavelength, and parametric dependence of these elements. The volume holographic element is modeled as a three-dimensional array of dipole scatterers phased by an illuminating wave. The resulting expression for the field in the far-zone consists of Rayleigh scattering dependencies multiplying a simple closed-form array factor. Additional insight is obtained through various implementations of thin grating decomposition, in which the thick holographic grating is treated as a series of cascaded thin gratings. Successful aspects of these and other approaches are combined in a comprehensive Monte Carlo analysis of real volume holographic optical elements, forming the basis of a hybrid raytracing diffraction theory which includes volume holographic effects. Paraxial analyses along with the above theory are then applied to single element, axial and off-axis cascade, and hybrid diffractive-refractive optical configurations for imaging and transforming applications. Practical configurations, some yielding bandwidths on the order of the visible spectrum, are analyzed. A detailed Laplace analysis is performed on holographic elements, determining their temporal and dispersive response throughout the pulsed-to-steady state continuum. High quality holographic elements and configurations are fabricated in silver halide emulsions, dichromated gelatin, and photoresists. These elements are used to experimentally verify the theoretical predictions from above. Wavefront quality and aberration is interferometrically measured and compared with theory.

2.3 Scattering of Light from Large Cylinders

Statement of the Problem and Objectives

The scattering of a plane electromagnetic wave by cylindrical obstacles is treated extensively in the literature but with an emphasis on the long wavelength case. In the optical regime it is interesting to study the short wavelength case in which ka varies from 10 to 1000 where k is the wave number and a is the radius. Moreover, it is important to study the scattered radiation for dielectric, absorbing, and perfectly conducting cylinders including polarization effects. Our objective is to contribute to the understanding of the possibilities of remote sensing and precision optical metrology of tiny fibers.

2.3.1 Activity During the Report Period

Rigorous solutions to the problem of scattering from dielectric and perfectly conducting cylinders are standard literature in electromagnetic theory. However, the solutions are analytically formidable, and it is not an easy task to consider variations in the radiation pattern caused, say, by varying conductivity or by radial profiles in the index of refraction. Also if one wishes to use diffraction-pattern-sampling methods for remote sensing, it is not obvious which portion, e.g., at what angle, one should sample these patterns.

Mustafa Abushagur is currently completing his doctoral thesis in which these topics are considered. A preliminary abstract of the thesis follows.

Extract from Doctoral Thesis

Scattering of Light From
Large Cylinders and Rough Surfaces

Mustafa Abushagur

Advised by Professor Nicholas George
The Institute of Optics, University of Rochester

Preliminary Abstract

The scattering of a plane electromagnetic wave by circular cylinders is analyzed. Patterns of the scattered intensity are plotted for dielectric and conducting cylinders for both polarizations of the incident field (parallel and normal to the axis of symmetry of the cylinder). For the conducting cylinder, the scattered field can be thought of as leading to an interference pattern between the fields diffracted by the edges of the cylinder and those reflected from its surface. For the dielectric cylinder, the intensity pattern can be divided into four regions: (a) for $0 < \phi < 10$; the field is mainly generated by the diffracted field, (b) for $10 < \phi < 90$; the field is generated by the interference between the refracted and reflected rays, (c) for $90 < \phi < 150$; the field results from the interference between the reflected rays and those refracted after they have gone through more than one multiple internal reflection, (d) for $150 < \phi < 180$; the fields result from the interference between the reflected rays and the refracted rays which have gone through one multiple internal reflection.

The pattern of the scattered intensity has a main lobe and a number of sidelobes. The spacings between the sidelobes are found to be inversely proportional to the factor ka . The sidelobes of the field scattered from a perfectly conducting cylinder are found to disappear faster in the parallel incidence case than in the normal incidence case as ϕ increases. For the two polarizations, the intensity patterns have a significant difference in that the contrast of the fringes is much larger with parallel incidence while the number of fringes is larger with normal incidence.

Approximate solutions are derived for both conducting and dielectric cylinders, using physical optics techniques. The approximate solutions show a very good agreement with the rigorous theory, although they are in much simpler forms. The intensity scattered by both kinds of cylinders is measured experimentally using two different methods. A photodiode is used to measure the intensity in one case. In the other method we use photographic film to record the data. Then, a combination of a microdensitometer and a computer are used to obtain curves of the intensity. Both experiments gave very good verifications of the theory.

2.3.2 Summary of Results

An extract of some of the findings on scattering from large cylinders is presented in this section of the progress report.

Figure 1 shows the theoretical prediction for the scattered intensity from a perfectly conducting cylinder with $ka = 330$ where $k = 2\pi/\lambda$, (a) is the radius, and λ is the wavelength. The plot is for the cylindrical angle ϕ in the range $5^\circ < \phi < 60^\circ$. The illumination is incident from the direction $\phi = 180^\circ$. This range of ϕ is chosen for this extract in order to show the difference in the extent of the interference pattern for two plane polarized waves: (upper in Fig. 1) E^\perp with the electric field polarized perpendicularly to the axis of the cylinder and (lower) E^\parallel with the electric field parallel to the cylinder axis.

The intensity scattered from a dielectric cylinder with a homogenous index of refraction, has a main lobe at $\phi = 0^\circ$, and a number of sidelobes (see Fig. 2). Unlike the conducting cylinder, the dielectric has sidelobes at all values of ϕ . The amplitude of the intensity decreases as ϕ increases and it is very small in the range $90^\circ < \phi < 150^\circ$. In the back-scattered range $150^\circ < \phi < 180^\circ$, the intensity becomes quite large, and it has a peak with a position that depends on the value of the index of refraction of the cylinder (for E^\parallel). In Fig. 2 the scattered intensity is plotted for a dielectric cylinder, with $ka = 330$ and $n = 1.457$, in the range $45^\circ < \phi < 90^\circ$. Again we emphasize the

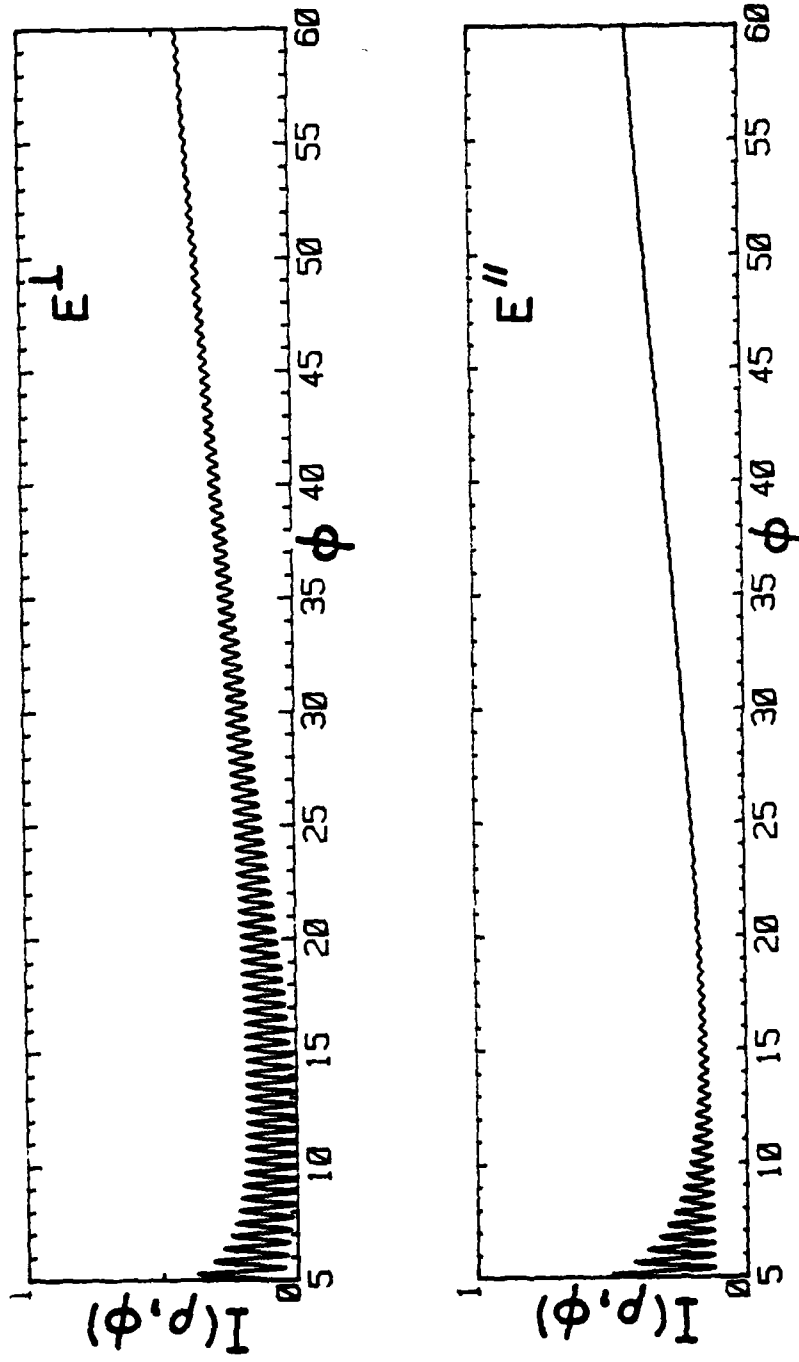

Fig. 1 The scattered intensity pattern for a conducting cylinder, $ka = 330$.

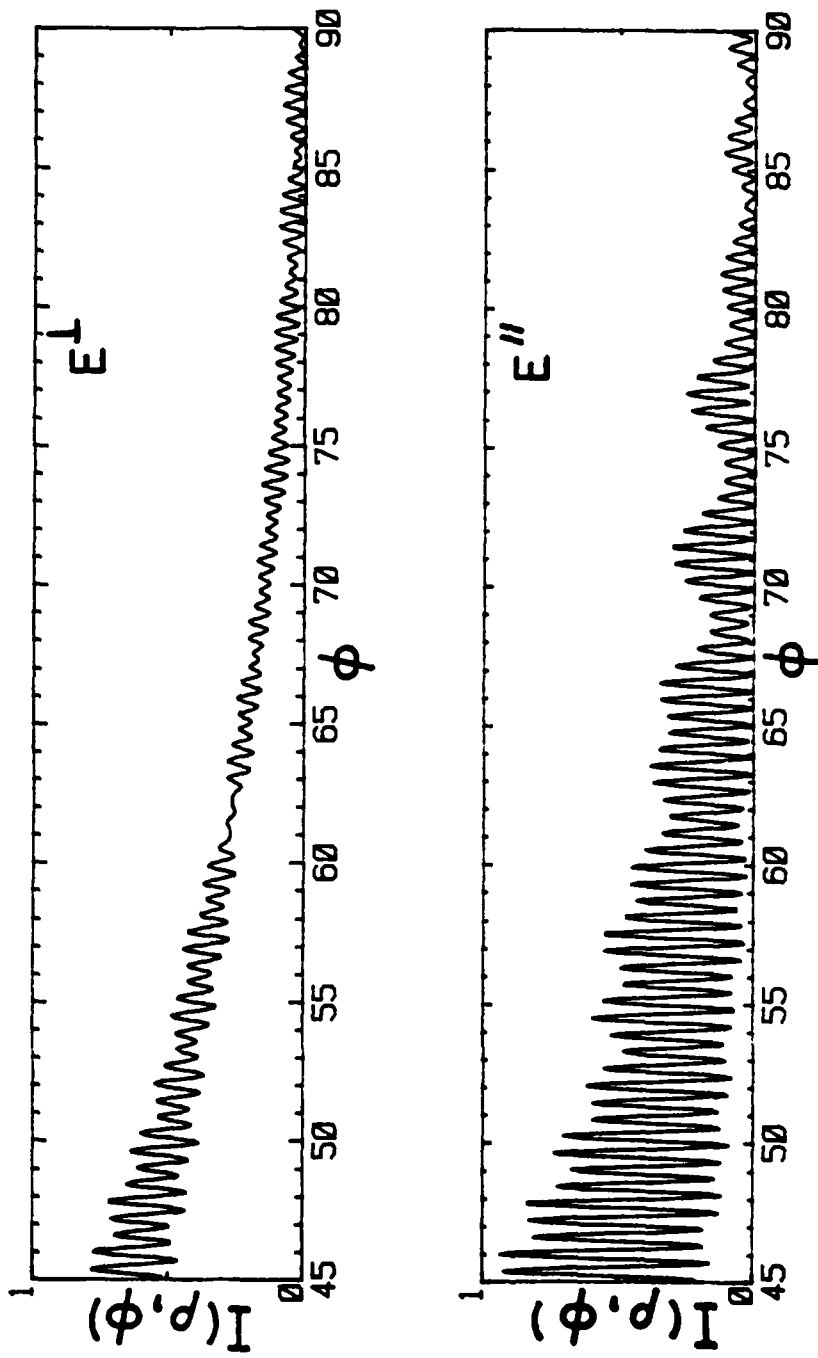

Fig. 2 The scattered intensity pattern for a dielectric cylinder, $ka = 330$, $n = 1.457$.

differences between the intensity patterns of the two different polarizations of the incident field. The number of sidelobes are the same for both patterns in the range $0 \leq \phi \leq 60^\circ$, but in the range $60^\circ \leq \phi \leq 90^\circ$ the intensity pattern for E'' has 48 sidelobes, while the intensity pattern for E^\perp has 52 sidelobes. Another difference between the two patterns is that the contrast of the fringes for E'' is much larger than those for E^\perp .

An experimental study has been conducted to verify the theory and to see if the notable differences in these patterns can be observed. The optical hybrid system used in the experiment is shown in Fig. 3. A He-Ne laser, operating at $\lambda = 6328 \text{ \AA}$, emits a plane polarized wave, which passes through a polarization rotator that enables us to change the polarization of the incident field. The cylinder to be illuminated is mounted in the center of a cylindrical chamber, designed specially for this experiment. The chamber has an open slot which extends for 200° and on which a 35mm film can be mounted and registered. On the top of the chamber a Deadal, Inc. 20601 rotary stage is mounted and an arm with an avalanche photodiode (RCA C30902E) at its end is mounted on the rotary stage. The output of the photodiode corresponds to the intensity of scattered light. The intensity data are collected with a microcomputer system driving the rotary stage through a prescribed program, and finished curves of intensity vs cylindrical angle ϕ can be obtained, as shown in Fig. 4. The resolution of the system is $\Delta\phi = 0.01^\circ$.

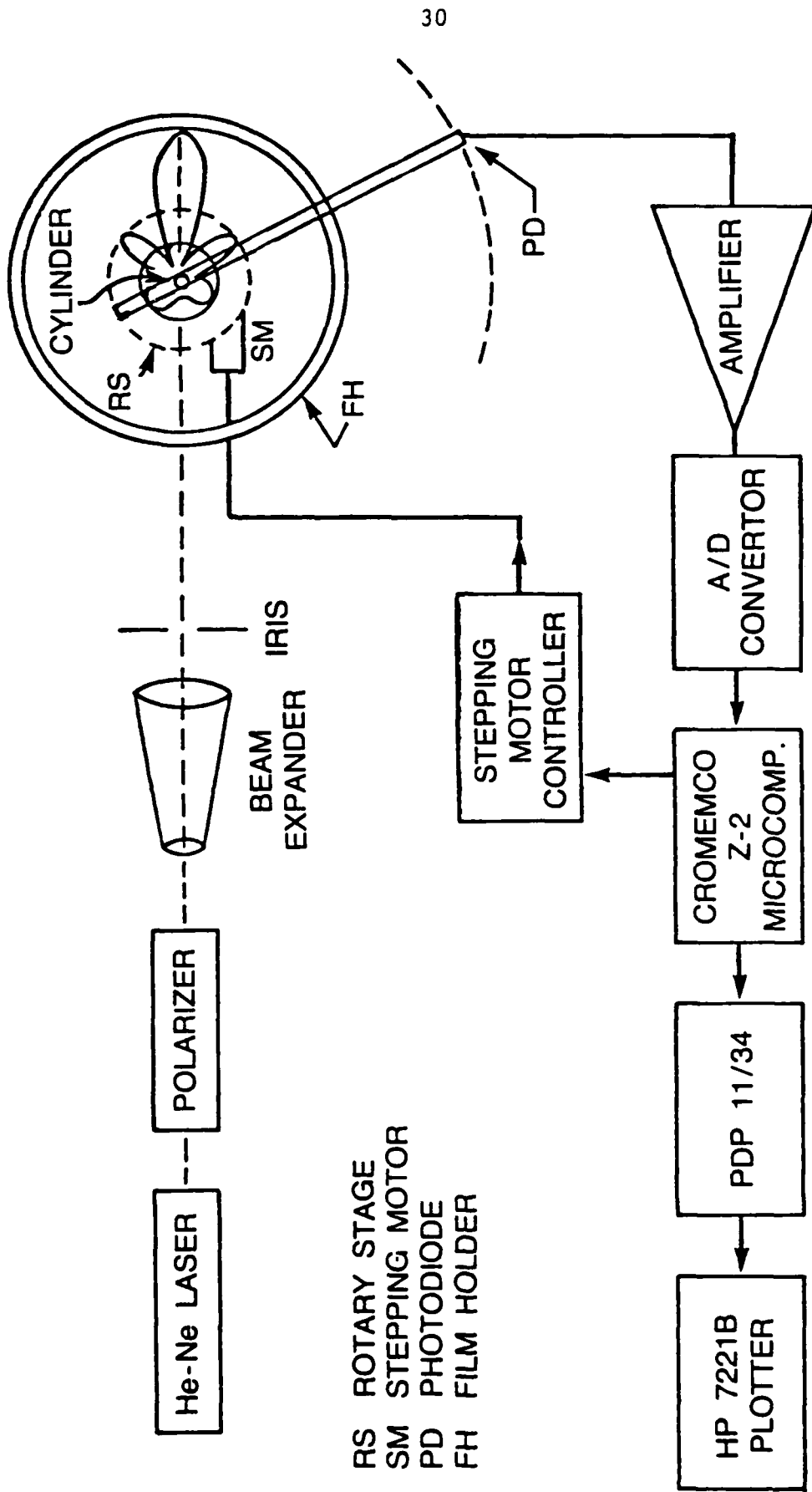

Fig. 3 An optical-hybrid system used in the measurement of the intensity scattered by a cylinder.

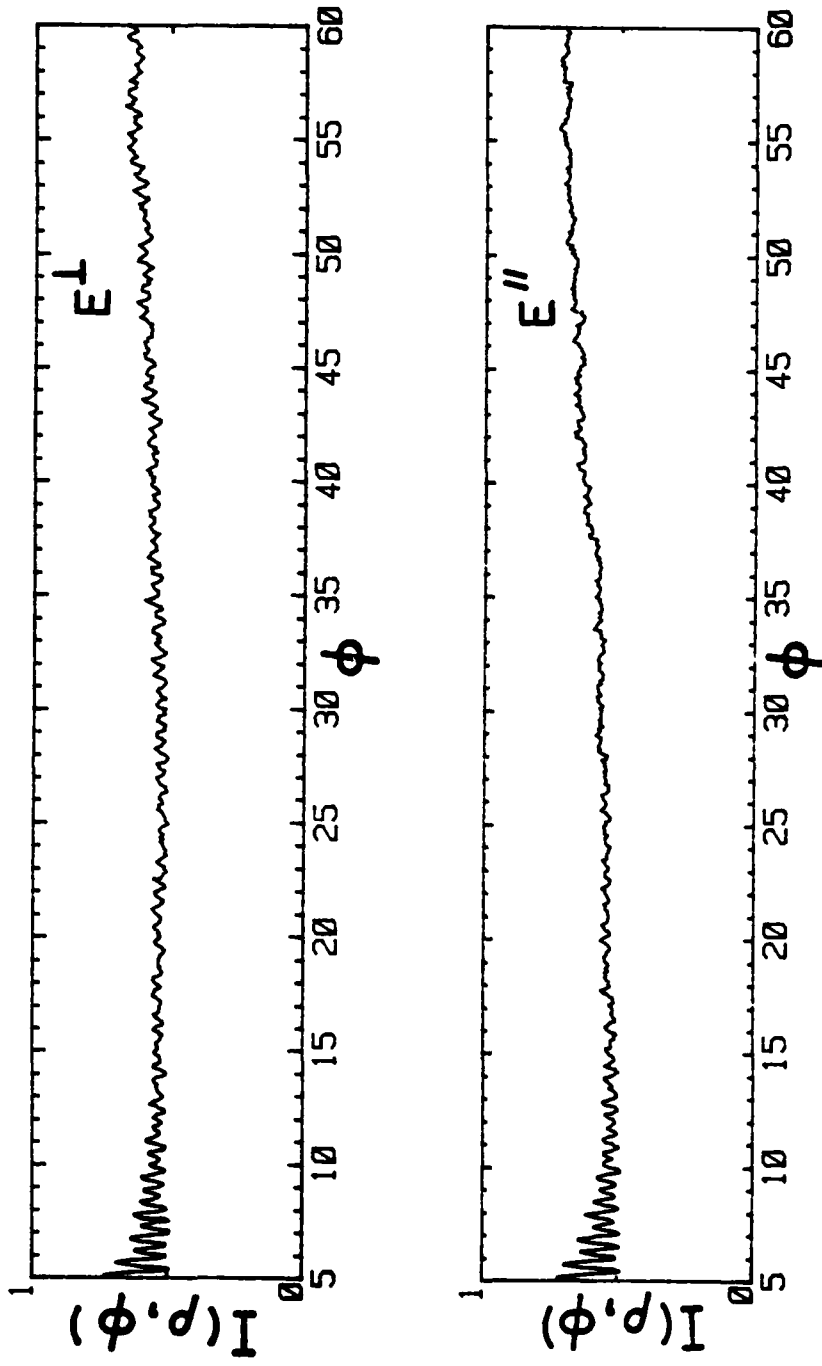

Fig. 4 The scattered intensity pattern measured experimentally for a conducting cylinder with $ka = 330$.

Data are presented in M. Abushagur's thesis for dielectric and for conducting cylinders. It appears that decided advantages in remote sensing are obtained for samples taken at angles ϕ that are in the range from 45° to 90° . The predicted differences for variations with incident polarization are readily observed. To illustrate the results, we show the intensity scattered by a metallic cylinder, again with $ka = 330$ in Fig. 4. The experimental results are in very good agreement with those plotted in Fig. 1; the spacings of the fringes are the same, and the fringes for the normal incidence exist only in the range plotted. Notice that they disappear at about $\phi = 20^\circ$ for the parallel incidence case. This research topic will be completed during the present contract period.

2.4 Scattering by Elliptical Apertures

Accomplishments During the Report Period

Diffraction in the far zone of an elliptical aperture has been described analytically. Through diffraction pattern sampling, it is possible remotely to measure aperture eccentricity to within very small limits. Far-zone patterns of small particles with elliptical cross section have also been observed, as a means of remotely determining their eccentricity.

2.4.1 Review of Problem

As pointed out in the 1982-83 proposal, diffraction pattern analysis is a useful technique in the detection of objects otherwise difficult to resolve with conventional imaging systems. Asbestos, for example, is a material made up of fibers whose width is typically less than 5 μm . Although many of these fibers are over 30 μm in length and are made up of bent and curved segments, fibers of length 10-15 μm are also very common. These may be modeled as prolate spheroids of high eccentricity.

Diffraction patterns of these particles have been observed using the system previously described (see Fig. 1). It is clear that the eccentricity of the particle may be measured directly from the diffraction pattern. The question of the accuracy attainable in this measurement led to the consideration of diffraction by elliptical apertures of various eccentricities.

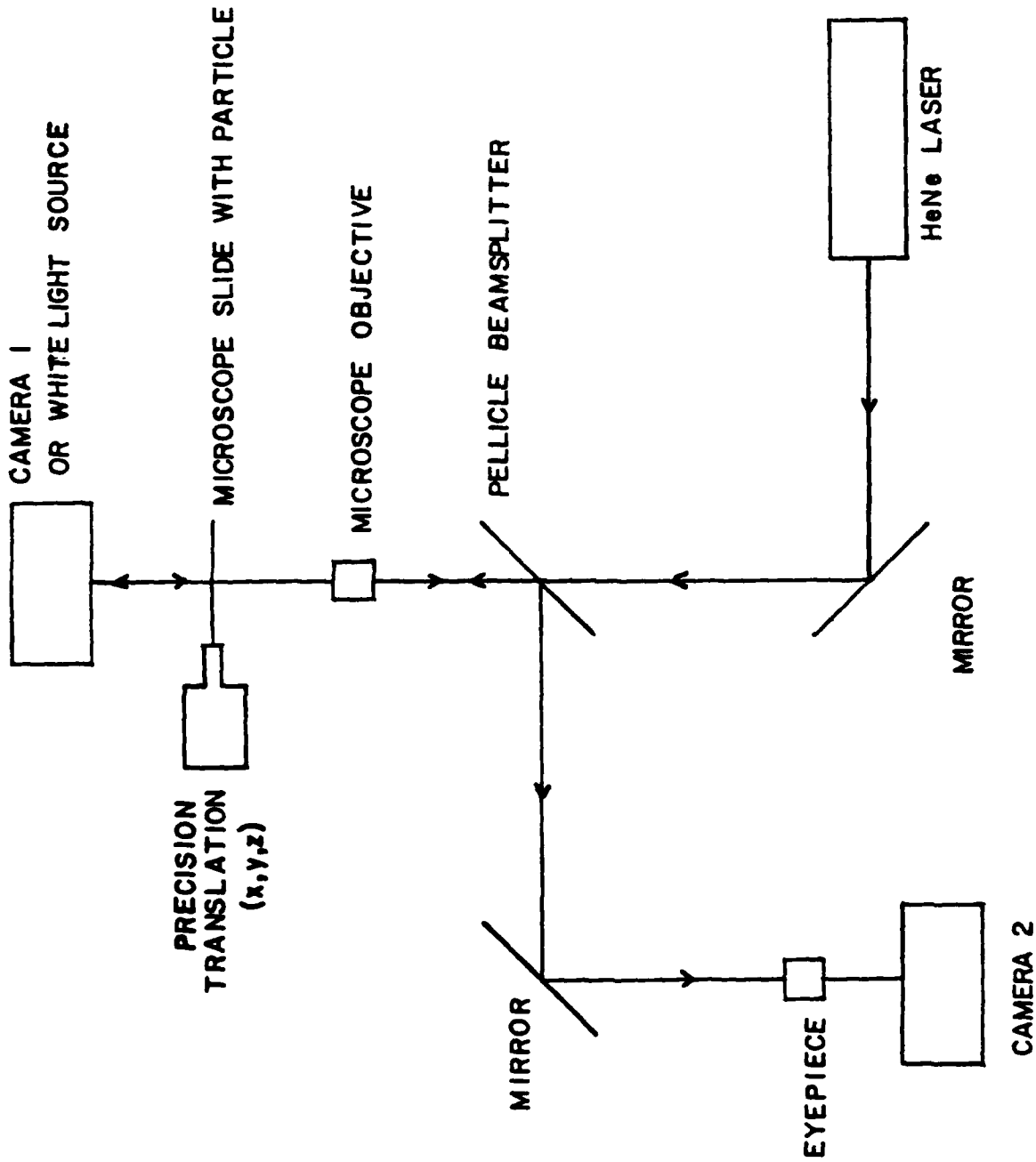

Fig. 1 Optical Transform and Object Visualization. In the setup the object is placed on the microscope slide and illuminated by a laser for recording of the transform at camera 1. In a second setup the object can be photographed at camera 2 under moderate magnification.

2.4.2 Summary of Results

Paul Kane is now preparing his M.S. Thesis, which is based on this work. The title page and abstract of this thesis are reproduced below. This is followed by an overview of the thesis contents.

Extract from M.S. Thesis:

Far Zone Diffraction by Elliptical Apertures and Particles

Paul Kane

Supervised by Professor Nicholas George
The Institute of Optics, University of Rochester

Abstract

Diffraction by an elliptical aperture has been studied theoretically using the methods of Fourier optics and experimentally. The result for the optical transform is used as a basis on which to consider the remote measurement of eccentricity. Apertures of various eccentricities are studied in a diffraction pattern sampling system. The accuracy attainable by this method as a function of aperture size and eccentricity is reported. A configuration is also described which allows the far zone diffraction pattern of individual ellipsoidal particles to be examined.

From the analysis it is found that an elliptical aperture has a far-zone pattern that has elliptical rings of constant intensity that of course go into the well-known Jinc pattern or Airy disc as the eccentricity goes to zero. In an optical transform setup, two observations about the patterns are made as follows:

- i) The major axis of the pattern is perpendicular to the major axis of the aperture.
- ii) The eccentricity of a single locus of constant intensity is the same as the eccentricity of the aperture.

Figure 2 shows experimentally observed optical transform patterns together with corresponding apertures. Transform plane patterns for apertures of eccentricity $\epsilon = 0.875$ and $\epsilon = 0.0$ (circular aperture) are shown. The apertures are shown on the right under a microscope at 25X magnification. The circular aperture has a diameter of 1.32 mm, while the elliptical aperture is of length 1.32 mm and a width 0.64 mm. The apertures were plotted by computer and, using the plot as a template, transferred by hand to red rubylith film. This was then photoreduced 26X to produce the apertures shown in Fig. 2.

In a separate aspect of this study the eccentricity of the apertures is remotely determined by measuring the distance to the first null in the corresponding diffraction patterns, along the major and minor axes of the pattern. This is accomplished by sampling the pattern with a Reticon 1024 element linear photodiode array along these two perpendicular directions. The Reticon output can be immediately displayed or sent to a digital computer for analysis. For the aperture of eccentricity $\epsilon = 0.875$, a comparison of the width of the central peak in each orthogonal direction yields an eccentricity accurate to within



(a)

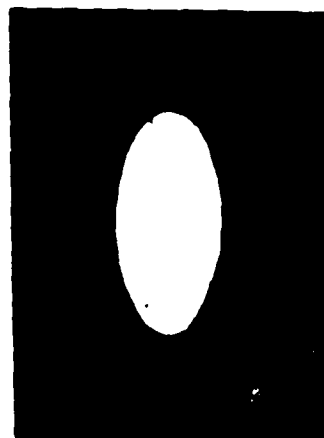

(b)

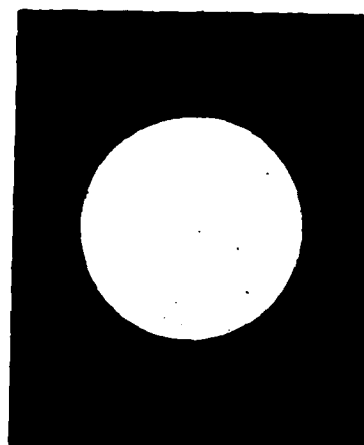

Fig. 2 Diffraction Patterns (a) and Apertures (b).

2.2%. Note that upon transfer of the computer plotted ellipse to the red rubylith film described earlier, it is possible to introduce errors into the elliptical shape of the aperture. These departures from the true ellipse introduce errors in the actual eccentricity of the aperture, and hence the measured eccentricity from the diffraction pattern. This project will be completed during this contract year by Paul Kane who will complete his M.S. studies in June 1983. Paul Kane will then start research on a Ph.D. thesis in the general area of automatic pattern recognition of particulates.

2.5 Image Understanding and Evaluation

Statement of the Problem and Objectives

The ability to judge automatically the quality of an image is very important in the field of image evaluation. A criterion to judge image quality that is reliable and independent of scene content over a wide range of imagery is sought. We propose to study image characteristics such as information content, entropy, and higher-order correlations using an electro-optics detector system. Our objective is to understand what characteristics are important in defining image quality and then to establish a method for automatically sorting imagery which is capable of being implemented at high rates. Initial research will center on a study of algorithms that are important in the assessment of image quality.

2.5.1 Status Report

Initial investigations into image evaluation included a study of the image power spectrum and how these data can be used for image quality measures. Dennis Venable has completed and successfully defended a Ph.D. thesis proposal on this research topic. Included below is the title page from this proposal.

In our experiments we use a ring-wedge detector for sampling in the optical transform plane.

We have performed several experiments to gain familiarity with this detection system. In one such experiment we have successfully sorted dichromated gelatin speckle plates photographically copied from master plates. In our study for algorithms that are important in image assessment, we have studied frequency moments in the transform plane and spikiness or edge content algorithms. This research is continuing.

Extract of Ph.D. Thesis Proposal:

Automatic Assessment of Image Quality
Dennis L. Venable
Supervised by Professor Nicholas George
The Institute of Optics, University of Rochester

Abstract

In the application of automatic image evaluation techniques, one important aspect to consider is image quality. The study of image quality by subjective photographic interpretation is a standard and well-known technique. However, it would be desirable to be able to measure image quality automatically and rapidly, independently of operator control. In order to accomplish this, one must first devise a quantitative measure of image quality. The objective of the research proposed in this document is to develop reliable techniques of evaluating image quality that are widely independent of the imaging system and the scene content. Ideally, the result of such a technique will be a rank value which will correlate with quality ranking as determined by subjective photo-interpretation. The proposed studies will encompass three main topics: 1) study the effects of film grain distribution on image quality; 2) develop a perturbation criterion of image quality; and 3) develop a criterion of image quality that can be applied reliably to sampled imagery.

2.6 Computer Generated Objects

In two of our research topics, it has been found desirable to generate special input objects. These may be of general usefulness to others in the optics community, and so they are described in this technical report. Since they are not commercially available, if an interested reader would like one of these masks for an experiment, within reason, we will supply them to qualified users at cost upon written request to the Principal Investigator. The masks will be briefly described in the next two sections. The details of our usage will be set forth in our research proposal for next year.

2.6.1 Generalized Input Object

The test charts are generated on 4" x 6" (approx.) microfiche with the actual usable window of the transparency at 13.5 mm square. They are plotted using 1,024 points by 1,024 points using a CalComp Model 925/1670 Computer Output Microfilm Plotter and Printer System. This has been interfaced to a CYBER 175 computer in the College of Engineering and Applied Science.

In our correlation studies, it is important to have an input object that has the main features of an aerial photograph, but also an object that has an autocorrelation function that is readily calculable. The object features should be a short correlation length with much fine detail containing also a

broad spectrum of spatial frequencies. The test object shown in Fig. 1 is of the function $(1 + \cos \alpha x^2)(1 + \cos \alpha y^2)$ where α is chosen so that detail at the extreme edges ranges from 1 cycle/mm to 32 cycles/mm. A set of 6 masks is used for our generalized input objects.

2.6.2 Poisson-Distributed Delta Functions

Figure 2 shows a mask designed to simulate Poisson-distributed delta functions on a 2-dimensional sheet. These masks have a variety of uses, e.g., in studies of particulate distribution, film grain noise, speckle, photon statistics and so on. These masks should also prove useful in the calibration of our diffraction-pattern-sampling apparatus. A set of masks was generated with the mean number of delta functions varying from 256 to 120,000 points per 13.5 mm square.

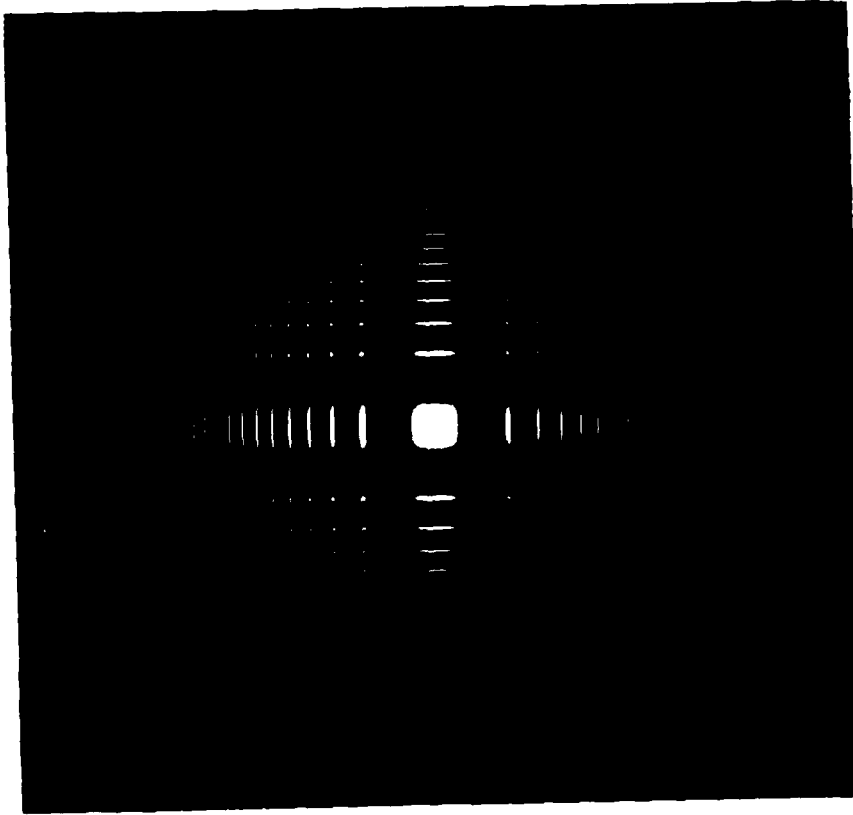

Fig. 1 Input test object for correlation experiments.

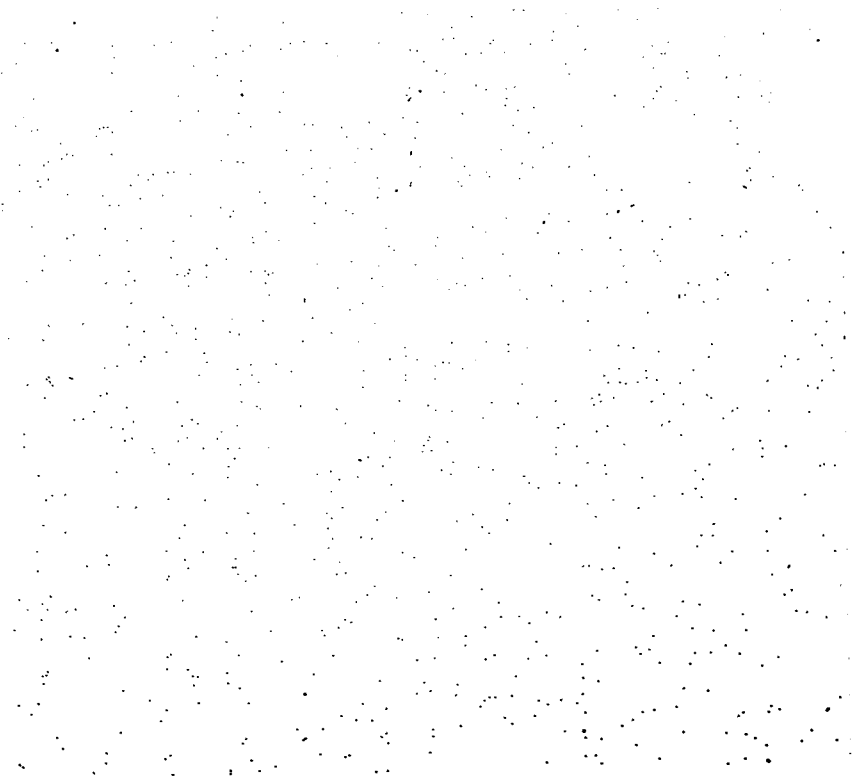

Fig. 2 Poisson distributed delta functions.

3.0 LIST OF PUBLICATIONS (1980)

3.1 Conference Report (Abstract Only)

N. George, G.M. Morris, T.W. Stone, and B.D. Guenther, "Achromatized Matched Filtering," J. Opt. Soc. Am. 70, 1613A (1980).

3.2 Publications

Nicholas George and G.M. Morris, "Diffraction by Serrated Apertures," J. Opt. Soc. Am. 70 6-17 (1980).

G.M. Morris and Nicholas George, "Matched Filtering Using Band-Limited Illumination," Opt. Lett. 5, 202-204 (1980).

M.A.G. Abushagur and Nicholas George, "Measurement of Optical Fiber Diameter Using the Fast Fourier Transform," Appl. Opt. 19, 2031-2033 (1980).

G.M. Morris and Nicholas George, "Frequency-Plane Filtering with an Achromatic Optical Transform," Opt. Lett. 5, 446-448 (1980).

G.M. Morris and Nicholas George, "Space and Wavelength Dependence of a Dispersion-Compensated Matched Filter," Appl. Opt. 19, 3843-3850 (1980).

N.D. Hickey, A Method of Image Subtraction for Process Control (M.S. thesis, University of Rochester, 1980 and Interim Scientific Report).

3.0 Continued

LIST OF PUBLICATIONS (1981)3.1 Conference Reports (Abstract Only)

G.M. Morris, R.E. Hopkins, T.W. Stone, C. Brophy, and J. Oschmann, "Achromatic Fourier Transformation: Theory and Practice," J. Opt. Soc. Am. 71, 1600 (1981).

3.2 Publications

G.M. Morris, "Image Recognition Using Noncoherent Illumination," article in Image Analysis Techniques and Applications, edited by P.N. Slater and R.F. Wagner, SPSE Conf. Proc. (SPSE, Washington, D.C. 1981), p. 87-90.

F. Dufresne de Virel, Automatic Hybrid Processor for the Measurement and the Comparison of Colors (M.S. thesis, University of Rochester, 1981 and Interim Scientific Report).

G.M. Morris, "Diffraction Theory for an Achromatic Fourier Transformation," Appl. Opt. 20, 2017-2025 (1981).

Nicholas George and G.M. Morris, "Optical Matched Filtering in Noncoherent Illumination," article in Current Trends in Optics (Taylor and Francis, London, 1981, pp. 80-94).

G.M. Morris, "An Ideal Achromatic Fourier Processor," Opt. Commun. 39, 143-147 (1981).

D.L. Venable, "A Coding Method For Optical Image Subtraction," (M.S. thesis, University of Rochester, 1981 and Interim Scientific Report).

3.0 LIST OF PUBLICATIONS (1982)

3.1 Conference Reports, Thesis Proposals

Dennis L. Venable, "Automatic Assessment of Image Quality" Ph.D. Thesis Proposal, March 1982.

ShenGe Wang, "Optical Transforms in White Light," Ph.D. Thesis Proposal, May 1982.

3.2 Publications

Thomas Stone and Nicholas George, "Bandwidth of holographic optical elements," Optics Letters 7, 445-447 (1982).

Chris Brophy and G.M. Morris, "Speckle in achromatic-Fourier-transform systems," J. Opt. Soc. Am. 73, 87-95 (1983).

3.0 LIST OF PUBLICATIONS (1983--Partial List only)

3.1 Conference Reports, Thesis Proposals

Justin Goding, "Poisson Processes in Optical Systems," Ph.D. Thesis Proposal, July 1983*.

Robert Rolleston, "Phase in Diffraction Pattern Sampling," Ph.D. Thesis Proposal, August 1983*.

3.2 Publications

Nicholas George and G.M. Morris, "Matched Filtering in White Light Illumination," SPIE vol. 388, Advances in Optical Information Processing (January 1983).

Thomas Stone, "Holographic Optical Elements," Ph.D. Thesis, University of Rochester (1983).

Mustafa Abushagur, "Scattering of Light From Large Cylinders and Rough Surfaces," Ph.D. Thesis, California Institute of Technology (1983)*.

Paul Kane, "Far-Zone Diffraction by Elliptical Apertures and Particles," M.S. Thesis, University of Rochester (1983)*.

* in preparation

4.0 PERSONNEL AND RELATED SUPPORT

4.1 Faculty

The faculty investigators who have been actively engaged and partially supported on this research sponsored by the Air Force Office of Scientific Research are listed:

1. Dr. Nicholas George Principal Investigator
Professor of Optics
2. Dr. G. Michael Morris Investigator
Assistant Professor of Optics

4.2 Graduate Research Assistants

Several excellent doctoral candidates are active in the research described in other sections of this report and some have been partially supported by funds from the subject contract. Their names and major topic of interest are listed below together with a reference to the section of this report which contains a summary of their research topic.

Student	Research Topic
I. Advanced Doctoral Students	
Mustafa A. Abushagur	(2.3) Scattering by large cylinders
Thomas W. Stone	(2.2) Holographic optical elements
Dennis L. Venable	(2.5) Image understanding
ShenGe Wang	(2.1.2) White light interferometry
II. Doctoral Students (2nd year)	
Madeleine Beal	Diffraction pattern sampling
Justin Goding	Statistical optics
Lyle Shirley	Remote sensing of lens quality

4.2 Graduate Research Assistants--continued

Student	Research Topic
III. Doctoral Students (1st year)	
Scott D. Coston	Particulate analysis of multi-cells
Ronald E. English, Jr.	Diffraction theory
Robert Rolleston	Phase in DPS
IV. M.S. Candidates	
Karen Allardyce	Scattering by rough surfaces
Paul Kane	(2.4) Scattering by elliptical apertures

4.3 Related Research Support

The Army Research Office has been providing partial support for several of the topics described in this report. The program is entitled "Image Correlation Using Noncoherent Illumination" and the program manager is Dr. B.D. Guenther. Joint sponsorship has been acknowledged on the publications resulting from this research on the topics for which it is appropriate.

Annual Report Submitted by

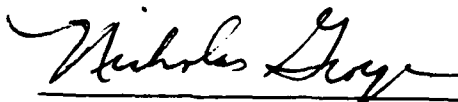

Nicholas George
Principal Investigator

NG:cng