

MICROCOPY RESOLUTION TEST CHART  
NATIONAL BUREAU OF STANDARDS 1963-A

2



ADA131409

THE ROCKET-TRIGGERED LIGHTNING INVESTIGATION  
1981 PROGRESS REPORT

Charles W. Schubert, Jr., Major, USAF  
Richard D. Richmond  
Flight Vehicle Protection Branch  
Vehicle Equipment Division

May 1983

Final Report for Period October 1980 through September 1981

Approved for Public Release; Distribution Unlimited.

DTIC FILE COPY

FLIGHT DYNAMICS LABORATORY  
AIR FORCE WRIGHT AERONAUTICAL LABORATORIES  
AIR FORCE SYSTEMS COMMAND  
WRIGHT-PATTERSON AIR FORCE BASE, OHIO 45433

83 08 16. 131

NOTICE

When Government drawings, specifications, or other data are used for any purpose other than in connection with a definitely related Government procurement operation, the United States Government thereby incurs no responsibility nor any obligation whatsoever; and the fact that the government may have formulated, furnished, or in any way supplied the said drawings, specifications or other data, is not to be regarded by implication or otherwise as in any manner licensing the holder or any other person or corporation, or conveying any rights or permission to manufacture use, or sell any patented invention that may in any way be related thereto.

This report has been reviewed by the Office of Public Affairs (ASD/PA) and is releasable to the National Technical Information Service (NTIS). At NTIS, it will be available to the general public, including foreign nations.

This technical report has been reviewed and is approved for publication.

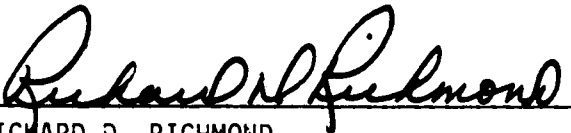
  
RICHARD D. RICHMOND  
Project Engineer

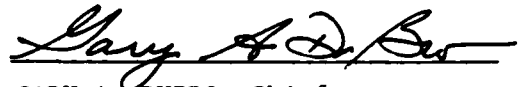
  
GARY A. DUBRO, Chief  
Atmospheric Electricity Hazards  
Group  
Flight Vehicle Protection Branch  
Vehicle Equipment Division

FOR THE COMMANDER

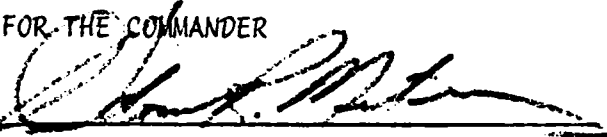
  
SOLOMON A. METRES  
Director  
Vehicle Equipment Division  
Wright-Patterson AFB

"If your address has changed, if you wish to be removed from our mailing list, or if the addressee is no longer employed by your organization, please notify AFWAL/FIESL W-PAFB, OH 45433 to help us maintain a current mailing list."

Copies of this report should not be returned unless return is required by security considerations, contractual obligations, or notice on a specific document.



UNCLASSIFIED

SECURITY CLASSIFICATION OF THIS PAGE(When Data Entered)

lightning interaction characteristics; however, all sensors and data links were proved to be operable. The primary finding was that lightning-object interaction data can be reliably and repeatedly acquired through the directing of triggered lightning to an instrumented target object. The report includes a detailed description of the system developed for the program, a discussion of system limitations, and results of the effort as of September 1981.

✓

A  
200  
1001  
2

UNCLASSIFIED

SECURITY CLASSIFICATION OF THIS PAGE(When Data Entered)

## FOREWORD

This report documents the first year results of a Rocket-Triggered Lightning Investigation conducted by the Atmospheric Electricity Hazards Group (FIESL), Flight Vehicle Protection Branch (FIES), Vehicle Equipment Division (FIE), Flight Dynamics Laboratory (FI), Air Force Wright Aeronautical Division (AFWAL) with joint participation by the French government research organization of Office National D'Etudes et de Recherches Aerospatiales (ONERA). The Investigation was initiated in October 1980 and was completed in September 1981. Field testing and data acquisition was accomplished from July through August 1981, at the Langmuir Laboratory for Atmospheric Research atop South Baldy Mountain.

The Rocket-Triggered Lightning Investigation was performed under the auspices of the AFWAL/FI Laboratory Independent Research Fund program for highrisk, high-payoff research and development. The in-house portion of the effort was conducted under AFWAL Work Unit Number 24020223, "Atmospheric Electricity Hazards to Aircraft", with Operations and Maintenance support provided by Technology/Scientific Services, Inc (T/SSI) under contract F3301-79-D0065. Logistical and operational support at the Mt Baldy test site was provided by the New Mexico Institute of Mining and Technology (NMIMT) under contract F3615-81-K-3415. Participation in the program by ONERA was established under Data Exchange Annex AF-79-F-7336 between the government of the United States of America and the government of France. The program was performed under the direction of Major Charles W. Schubert, Jr. and Mr. Richard D. Richmond, both of AFWAL/FIESL.

The authors wish to thank Prof C. B. Moore and the Langmuir staff for their vital overall support of the field test operations. We extend our appreciation to Dr. Carl Baum of the Air Force Weapons Laboratory for his technical advice on the design and instrumentation of the Lightning Strike Object. We also thank Mr. A. Serrano and Mr. D. Driver of T/SSI for their persistence and innovation in the development, operation and maintenance of test systems.

We particularly acknowledge Messers Taillet, Boulay, LaRoche and others at ONERA for their strong support of the investigation. The development by ONERA of a reliable system for the triggering of lightning provided the basic foundation upon which this investigation could build.

## TABLE OF CONTENTS

SECTION	PAGE
I INTRODUCTION	1
1. Program Background	1
2. Purpose of Report	2
II TEST SYSTEM DESCRIPTION	3
1. Geographical Location	3
2. RTLI Test Scaffold	5
3. Wire-and-Rocket Triggering System	5
4. Lightning Strike Object	11
5. Sensors	11
6. Data Transmitting and Recording System	21
7. Data System Limitations	23
III FIELD TESTS	27
1. Purpose of Tests	27
2. Test Configuration	27
3. Test Results	28
IV CONCLUSIONS	41
1. Program Findings	41
2. Recommended System Modifications	42
APPENDIX A CML B-DOT SENSOR DATA SHEET 1106	45
APPENDIX B FPD D-DOT SENSOR DATA SHEET 1116	48
APPENDIX C SLOT SENSOR DATA SHEET	51
APPENDIX D SPECIFICATIONS OF THE 301X PEARSON CURRENT TRANSFORMER	54
APPENDIX E NMINT TECHNICAL REPORT ON THE TRIGGERING OF LIGHTNING WITH WIRE-TRAILING ROCKETS DURING TRIP '81	56
REFERENCES	74

## LIST OF ILLUSTRATIONS

FIGURE		PAGE
1	Rocket Triggered Lightning Investigation Test Location	4
2	Lightning Strike Scaffold Descriptive Illustration	6
3	Lightning Strike Scaffold	7
4	Rocket on Launch Rail	8
5	Wire Bottle	9
6	Ground-Based Rocket Launchers	10
7	TIPSY Rocket Launch Platform	10
8	Lightning Strike Object Descriptive Illustration	12
9	Fields Detected by B-Dot Sensor	15
10	Slot Sensor	18
11	Current Transformer	19
12	Wire Pair System	20
13	Data Transmitting and Recording System	22
14	Waveform Processing Example	24
15	Distant Views of Rocket-Triggered Lightning Strikes	30
16	Nearby Views of Rocket-Triggered Lightning Strikes	31
17	High Detail View of Rocket-Triggered Lightning Strike	32
18	Rocket-Triggered Lightning Strike Photographed from Air Force Instrumentation Van	33
19	Unprocessed LSO Data from Lightning Strike of 14 August 1981, 13:43:13 MST	35
20	Wire Pair Waveform from Lightning Strike of 14 August 1981, 13:43:13 MST	36
21	Unprocessed LSO Data from Lightning Strike of 14 August 1981, 13:47:52 MST	37
22	Wire Pair Waveform from Lightning Strike of 14 August 1981, 13:47:52 MST	38
23	Unprocessed Waveform from Lightning Strike of 14 August 1981, 13:37:20 MST	39
24	Lightning Magnetic Fields and Sensor Polarities	40

## LIST OF ILLUSTRATIONS (Concluded)

FIGURE		PAGE
E-5a	Acoustic Reconstructions of the Thunder Source Locations for the Second Triggered Lightning on Day 81211 (July 30, 1981).	65
E-5b	Acoustic Reconstructions of the Thunder Source Locations for the Second Intra-Cloud Lightning that Lowered Positive Charge from the Region of the "Lower-Positive-Charge-Center" Created by the Rocket-Triggered Lightning at 13:03:08 MST.	66
E-5c	Acoustic Reconstructions of the Thunder Source Locations for the Intra-Cloud Lightning that Lowered Positive Charge from below the Free Balloon. This Flash was Caused by the 'Lower-Positive-Charge-Center' Created Earlier by the Rocket-Triggered Lightning.	67
E-1	A View of the French Rocket Launchers and the Instrumentation Tripod Used to Study the Effects of Triggered Lightning at Langmuir Lab During 1981. The Tripod is 18 m High and Supports 3 Launchers and the USAF Simulated Aircraft Fuselage.	70
E-2	A View of the Tripod and the USAF Simulated Aircraft Fuselage Instrumented to Measure Lightning Currents.	71
E-3	A Photograph of the French Instrumentation Shelter Used to Measure Lightning Currents.	72
E-4	A View of the Top of the Instrumentation Tripod Showing the Insulators Supporting the Platform, the Rocket Launchers, and the Wire Bobbins that Feed the Wire Trailed by a Rocket.	73

## SECTION I

## INTRODUCTION

## 1. PROGRAM BACKGROUND

The Rocket-Triggered Lightning Investigation (RTLII) program evolved as a result of research activities conducted independently by the Atmospheric Electricity Hazards Group (AFWAL/FIESL) and the French government research organization of ONERA. At AFWAL/FIESL, exploratory development programs have been conducted since the mid-1970s to determine means of protecting aircraft from the hazards of atmospheric electricity. Empirical data on lightning characteristics and effects is needed by AFWAL/FIESL for use in the development of accurate lightning-aircraft interaction computer models and in the design of lightning threat simulators. Such data is extremely difficult to acquire since the exact location and time of a natural lightning strike cannot be predicted. As a particular consequence, very little information is presently available on the nearby and direct strike electromagnetic characteristics of lightning. The feasibility of employing triggered lightning for the acquisition of data was considered by AFWAL/FIESL as early as 1976, and was pursued in the Laser-Triggered Lightning Experiment (LTLE) conducted in 1973 and 1979. It was recognized at that time that triggered lightning could solve the long-standing, and often frustrating, problem of lightning data acquisition through the directing of triggered flashes as near as desired to measurement instrumentation. Moreover, triggered lightning could find application in the direct strike testing of aircraft systems and subsystems. In such testing, strikes could be made to aircraft components before hardening to determine threat effects and after hardening to ascertain whether adequate protection measures have been taken. Finally, a close examination of nearby triggered strikes could provide information on lightning propagation physics and might reveal lightning threat mechanisms to aircraft not yet recognized. A brief description of the LTLE concept and silent film footage of the experiment appear in References 1 and 2 respectively.

During the field test phase of the LTLE program, unusually weak thunderstorm conditions persisted, and the triggering of lightning with

a laser beam could not be realized. However, during the test period, several lightning flashes were triggered from marginal storms with a wire-and-rocket system operated by personnel from ONERA. The wire-and-rocket system employed by ONERA had been developed to a high degree of sophistication and reliability over several years of testing at St Privat d'Allier in France. In research programs conducted by several organizations in France, triggered lightning was used primarily to investigate effects on power lines and communications systems. Reference 3 provides a summary of the research conducted at St Privat over an eight-year period, and describes the facility developed. Because of a relatively low occurrence of thunderstorms at the French test site, a decision was made to move test operations to South Baldy Mountain in New Mexico for several years beginning in 1979.

The mutual interest of AFWAL/FIESL and ONERA in triggered lightning research led to the establishment, in late 1980, of a joint two-year Rocket-Triggered Lightning Investigation program. The first year of the RTLI program, recently completed, has been devoted to system development and to verification of the testing concept. Acquisition of data on lightning characteristics and effects will receive primary emphasis during the second program year, with field tests to be accomplished in the summer of 1982.

## 2. PURPOSE OF REPORT

The purpose of this report is to describe the first year progress of the RTLI program. During this year, a Lightning Strike Object (LSO) was designed, fabricated and instrumented. A Lightning Strike Scaffold capable of elevating the LSO above the ground plane was constructed atop South Baldy Mountain, near Socorro, New Mexico. Lightning Simulation Tests on the LSO were conducted at the Atmospheric Electricity Hazards Research Facility at Wright-Patterson Air Force Base, Ohio. During the summer thunderstorm season, the LSO was hoisted into the Strike Scaffold and was subjected to over forty nearby and direct triggered lightning strikes. Instrumentation capable of recording high resolution data over the full duration of a lightning flash was not available for the 1981 program. However, preliminary short time-window data was acquired, and all LSO sensors and instrumentation links were proved to be operable.

## SECTION II

## TEST SYSTEM DESCRIPTION

Among the most significant accomplishments in the first year of the RTLI program has been the development and operation of a working system for determining triggered lightning effects on a non-grounded metallic object. Various aspects of that system - the location, the hardware and the instrumentation - are described in this section.

## 1. GEOGRAPHICAL LOCATION

The test site for the Investigation was established atop South Baldy Peak in the Cibola National Forest, near Socorro, New Mexico. The South Baldy location was chosen because of the high incidence of thunderstorms in the vicinity and because of the nearby proximity of thunderstorm research facilities. An average of 60 storms occur in the South Baldy area during the summer months. A large percentage of these storms form directly over Baldy peak, or drift over the peak from the surrounding valleys. Most often, the storm activity begins in the early afternoon and continues until nightfall. The Irving Langmuir Laboratory for Atmospheric Research, located on a ridge about 1.5 kilometers south of the mountain peak, serves as a data collection center and focal point for thunderstorm research in the area. The Laboratory is manned primarily by New Mexico Institute of Mining and Technology personnel and is operated during the summer months. The geography, climatology and facilities at Langmuir are described in Reference 4.

The test site for the 1981 RTLI program was stationed about 400 meters south of Baldy peak and about 1.7 kilometers north-northwest of the Langmuir Laboratory building at the position shown in Figure 1. The site elevation, at 3.2 kilometers, is about 60 meters lower than the peak of South Baldy. A clear, unobstructed, view of the entire RTLI test area was possible from the Langmuir building observation deck. The test site was accessible only by a single dirt mountain road about 14 kilometers long, which facilitated safety monitoring during rocket launches. Airspace above the site was restricted, reducing the possibility of an aircraft-rocket mishap.

Logistical and technical support at the test site was provided by the Langmuir Laboratory. Key elements of support included real-time weather radar and field mill data; both vital for the monitoring of conditions favorable for the triggering of lightning. The Laboratory also provided a radio communications network for use by the various research parties atop the mountain and coordinated test operations among the various research teams present.

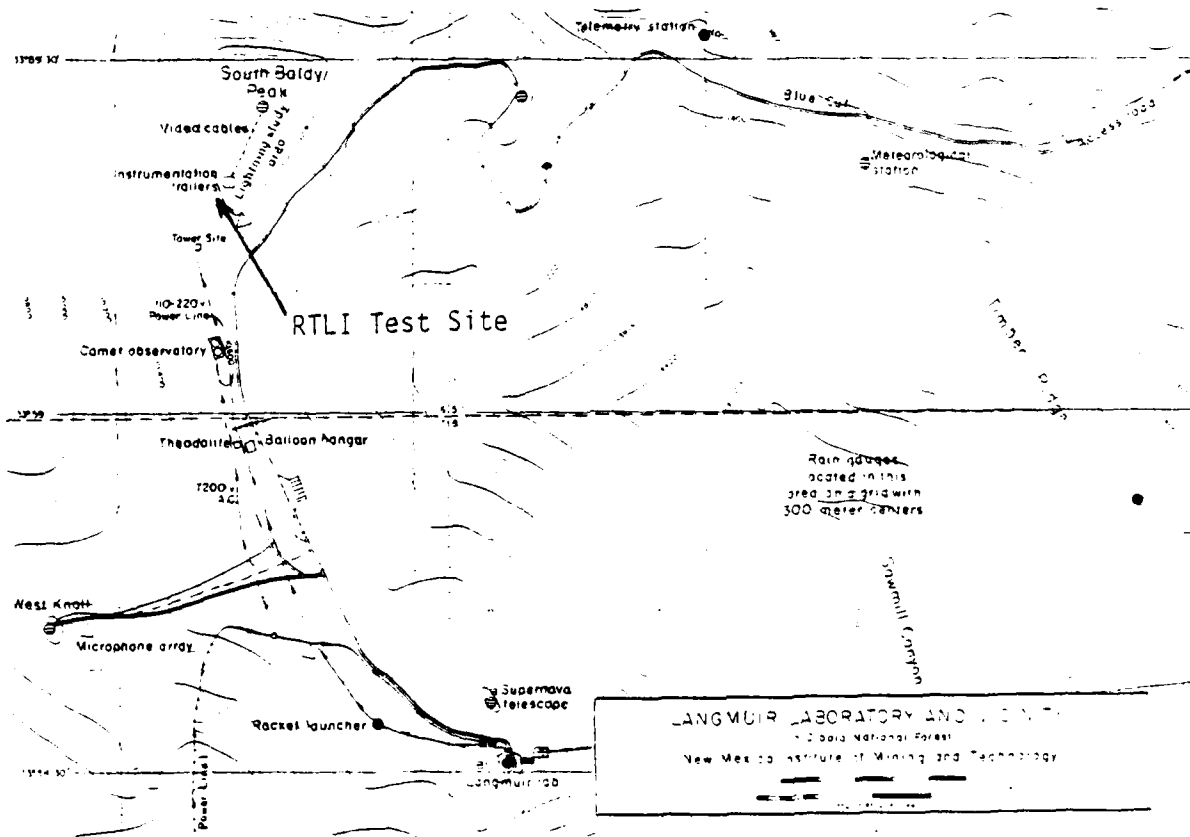

Figure 1. Rocket Triggered Lightning Investigation Test Location

## 2. LIGHTNING STRIKE SCAFFOLD

The Lightning Strike Scaffold, a structure designed to elevate the Lightning Strike Object above the ground plane, was a central component of the South Baldy RTLI test site. The Scaffold, constructed by NMIMT personnel, consisted essentially of three vertical telephone poles topped by a triangular wooden platform. The telephone poles, which served as the Scaffold legs, were spaced approximately five meters apart. The Scaffold height was approximately 20 meters. The wooden platform atop the Scaffold provided mounting for three wire-and-rocket lightning triggering units. Six additional triggering units were installed on the ground in a semicircular arrangement around the Scaffold base. A current waveform recording system operated by the ONERA research team was installed on the ground between the three Scaffold legs. The LSO was suspended on non-conductive, polypropylene rope interior to the Scaffold and beneath the platform top. A data link with the LSO was established with a fiber optics bundle inside a plastic hose which led from the LSO to a nearby instrumentation van. Access to the platform atop the Scaffold was provided by a large crane which was parked adjacent to the Scaffold. The various parts of the Lightning Strike Scaffold system are identified in Figure 2 and many can be seen in the photograph of Figure 3.

## 3. WIRE-AND-ROCKET TRIGGERING SYSTEM

A wire-and-rocket system developed over the past several years by a team of researchers from France was used to trigger lightning strikes onto and nearby the Lightning Strike Scaffold. Each triggering unit consists of a rocket, a wire bottle and supporting hardware, including a launch rail. Figure 4 shows one of the rockets on a launch rail ready for firing. The rockets, marketed in France as anti-hail devices, each consist of a single-use solid fuel rocket motor encased in a plastic body 84.7 centimeters long. The rockets are capable of hoisting the triggering wire to an altitude of 700 meters in 5 seconds.

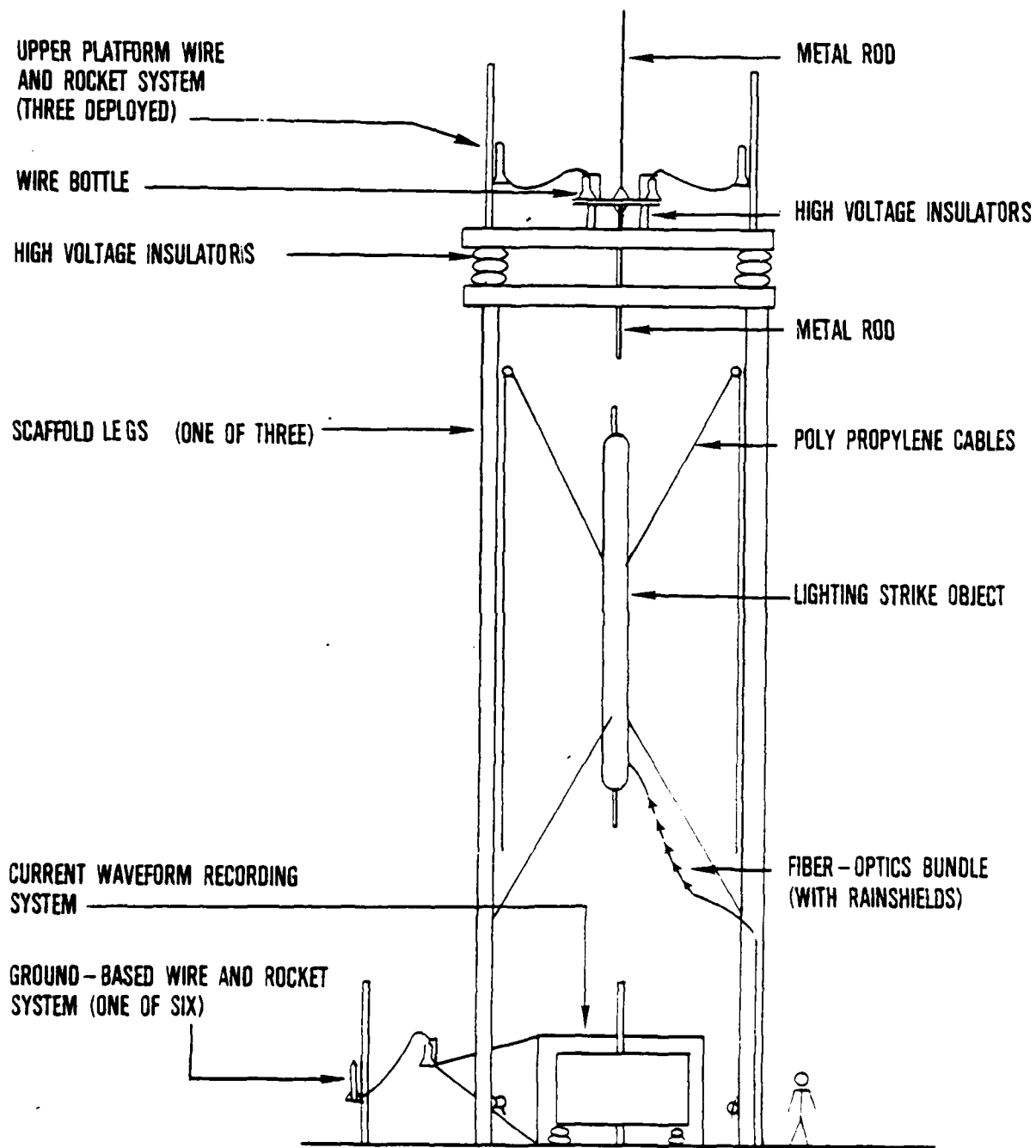

Figure 2. Lightning Strike Scaffold Descriptive Illustration



Figure 3. Lightning Strike Scaffold



Figure 4. Rocket on Launch Rail

The triggering wire is released off the end of a rigid (nonrotating) spool which is housed inside a small metal bottle. Each wire bottle contains several thousand meters of 0.2 millimeter diameter steel wire; however, only 100 to 500 meters of wire are used in a typical rocket launch. To absorb shock and to minimize wire breakage during rocket acceleration, an elastic cord is connected between the rocket and the first portion of the triggering wire. This cord is visible in Figure 5, extending above and to the left of the wire bottle.

For the RTLI program, a total of 13 wire-and-rocket units were deployed on a given day. Three of the units were installed at the top of the Scaffold to trigger lightning onto the LSO. The wire bottles for these units were attached to a metal rod which extended downward through an opening in the Scaffold platform. During triggering events, the metal



Figure 5. Wire Bottle

rod served as a corona point to direct lightning current from the wire bottle across an open air gap to the LSO. Six additional wire-and-rocket units were emplaced on the ground at the base of the Strike Scaffold. The aim of these units was to direct lightning strikes adjacent to, but not necessarily onto, the LSO. Figure 6 shows three of the ground-based rocket launchers and corresponding wire bottles. A fourth rocket system, leftmost in the Figure 6 photograph, was used to transmit electrostatic data, and was not part of the wire-and-rocket triggering system. Four additional triggering units were placed on a metal platform (TIPSY) several tens of meters to the east of the Lightning Strike Scaffold. The TIPSY platform, visible in the background in Figure 6, is shown more clearly in Figure 7. The TIPSY wire-and-rocket units were used for French experiments in which a portion of the triggering wire was replaced by a non-conductive line.

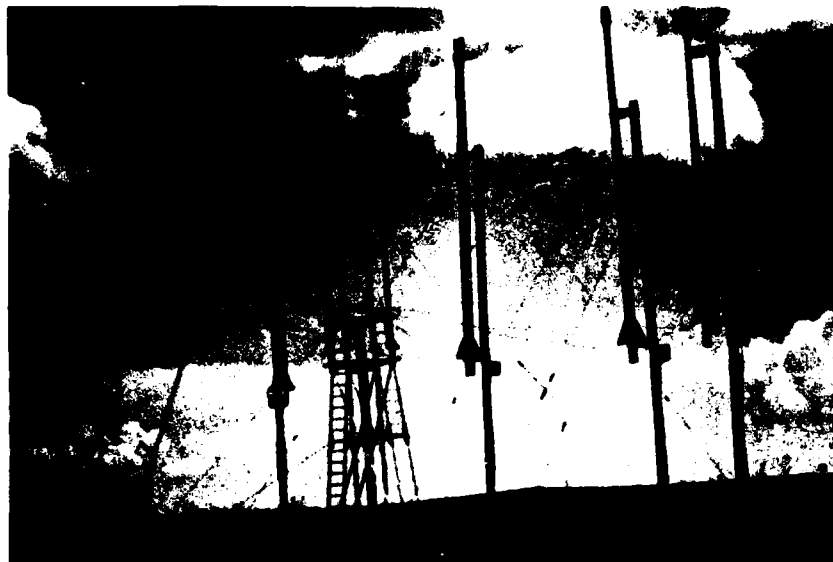

Figure 6. Ground-Based Rocket Launchers

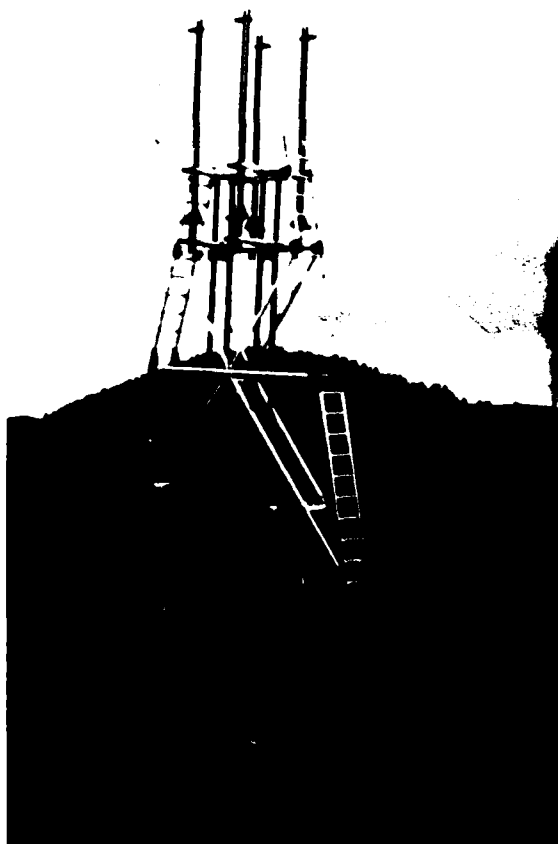

Figure 7. TIPSy Rocket Launch Platform

#### 4. LIGHTNING STRIKE OBJECT

The Lightning Strike Object is a cylinder instrumented to acquire and transmit data on the electromagnetic fields and transient currents produced by nearby and direct lightning strikes. The LSO, diagrammed in Figure 8, is constructed of sheet aluminum and has dimensions of 8.5 meters in length and one-half meter in diameter.

The two ends of the LSO are rounded to a hemispherical shape to minimize corona which would form on sharp edges under high current and voltage. Pipe flanges on each end of the LSO will accept standard two-inch diameter steel pipe, which may be added to extend the electrical length of the cylinder. Three magnetic field sensors, three electric field sensors and a slot antenna current detector are installed on the exterior surface of the LSO and a current transformer is mounted on one of the LSO end pipe extenders. A wire pair with a selectable termination (open, short, or resistive) is installed along the length of the LSO interior. Measurement of the current induced on the wire pair is accomplished by means of a voltage detector at the chosen termination. Circular apertures near each end of the LSO may be closed with aluminum, covered with a composite material or left open. Sensor output signals are fed through logarithmic amplifiers to fiber optic transmitters located in the LSO adjacent to each sensor. The signals are then transmitted over a fiber optic cable bundle to recording instrumentation, which was located in a van approximately 40 meters away during the Mt Baldy tests. The LSO fiber optic transmitter system is powered by a rechargeable battery pack. Battery pack recharging is accomplished with an extension cord which is disconnected from the external source, reeled up and enclosed within the LSO during test operations.

#### 5. SENSORS

The LSO sensors were chosen to enable a full characterization of lightning-generated fields and currents at the surface of the LSO. The magnetic field sensors and electric field sensors are designed to respond to the derivative of the fields, and are thus referred to as B-dot and E-dot sensors, respectively. The current transformer outpost is

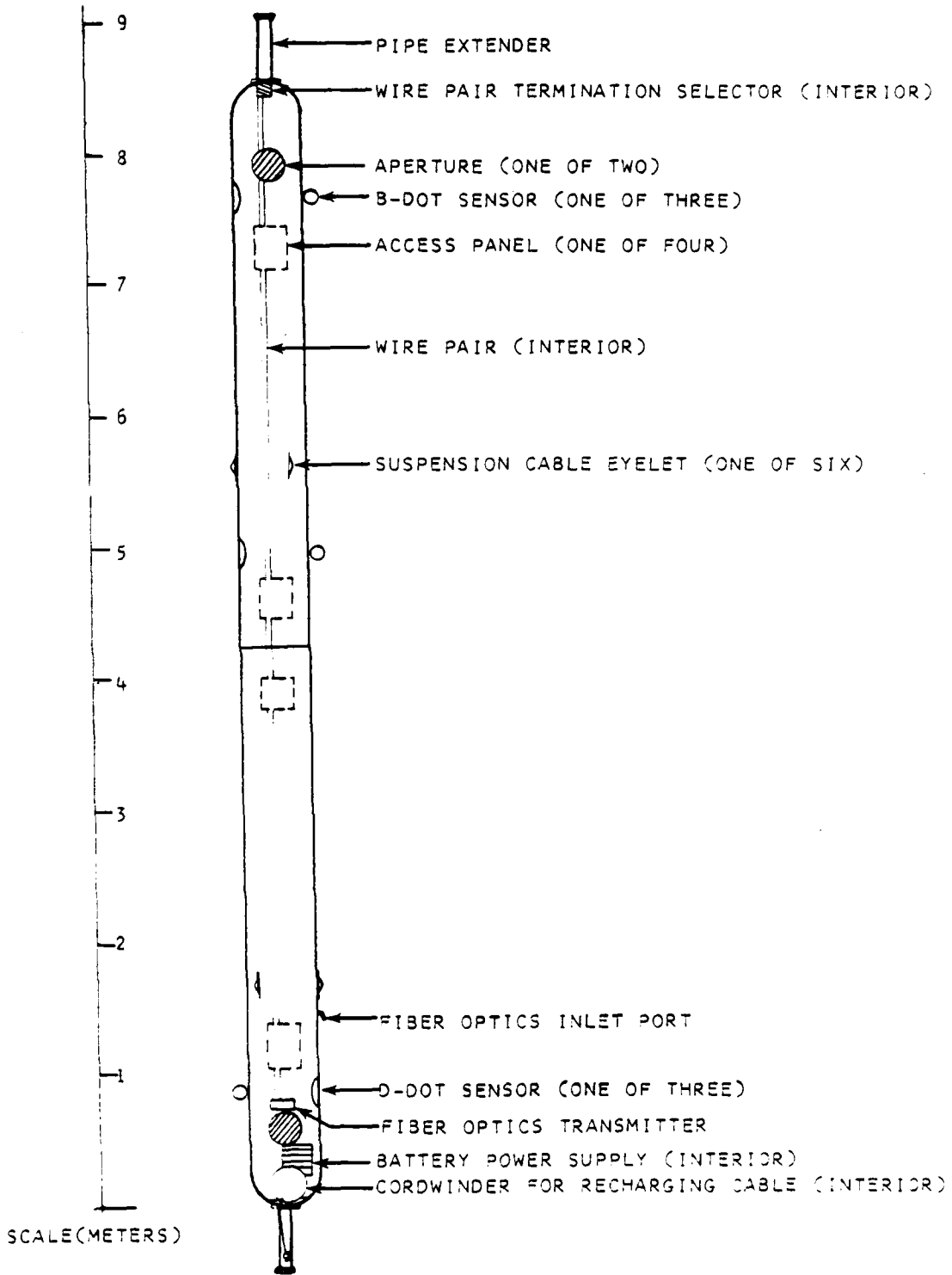

Figure 8. Lightning Strike Object Descriptive Illustration

proportional to the current amplitude on the LSO surface and the slot antenna output is proportional to the current derivative. The wire pair provides data on induced currents within the LSO, which are proportional to the derivative of the external fields. Following is a discussion of each of the sensor types.

a. Magnetic Field

Cylindrical Moebius Loop (CML) sensors are installed at three locations on the LSO exterior to provide information on the transient magnetic field ( $B\text{-dot}$ ) immediately above the LSO surface. The location of the sensors on the LSO is shown in Figure 8. The sensors near the top and center are mounted collinearly on the same side of the cylindrical LSO surface; the sensor near the bottom is located 180 degrees around the LSO circumference from others. The sensors employed, EG&G type CML-7(R), were manufactured specifically for lightning research and are described in detail in EG&G data sheet 1106, which is provided in the appendix of this report. The sensors were used as manufactured, except that the base plate shown on the data sheet was removed so that installation on the curved surface of the LSO could be accommodated.

From the EG&G data sheet, the CML sensor output,  $V_B$ , is given by

$$V_B = \bar{A}_{eq} \cdot \frac{d\bar{B}}{dt} \quad (1)$$

where

$$A_{eq} = \text{sensor equivalent area } (2 \times 10^{-2} \text{m})$$

and

$$\bar{B} = \text{magnetic flux density vector (in teslas).}$$

Ignoring end field effects, a direct strike current,  $I$ , down the length of the LSO will produce magnetic field lines,  $\bar{B}_I$ , in circles concentric with the LSO longitudinal axis. The sensors are mounted such that  $\bar{A}_{eq}$  is parallel to such  $\bar{B}$  lines, and in this case Equation 1 becomes

$$V_B = A_{eq} \frac{dB_I}{dt} \quad (2)$$

A straightforward application of Ampere's Law, again ignoring end effects, results in the following interrelationship between  $B_I$  and  $I$ :

$$B_I = \frac{\mu}{2\pi r} I \quad (3)$$

where  $\mu$  is the permeability constant ( $1.26 \times 10^{-6}$  h/m) and  $r$  is the distance from the LSO center axis (0.25 m). Differentiation of Equation 3 and substitution into Equation 2 results in

$$V_B = A_{eq} \frac{\mu}{2\pi r} \frac{dI}{dt} \quad (4)$$

Insertion of the appropriate numerical constants into Equation 4 and integration over a time period  $t'$  produces the following equation for currents along the LSO surface, in amperes, as a function of sensor output, in volts:

$$I(t') = 6.3 \times 10^7 \int_0^{t'} V_B(t) dt \quad (5)$$

The numerical constant  $6.3 \times 10^7$  has units of amperes/volt-second.

Although Equation 5 is useful for a rough examination of the data, it must be used with some caution in a detailed analysis. During a lightning strike to the LSO, magnetic fields may be generated from several sources, as illustrated schematically in Figure 9. Magnetic fields radiated from the attached channel ( $\bar{B}_{RA}$ ), from nearby lightning flashes ( $\bar{B}_{RA}$ ) and from corona ( $\bar{B}_{RC}$ ) will link directly to the sensor and produce a sensor output  $V_B'$ . Such fields and corresponding  $V_B'$  have been ignored in the Equation 5 derivation. As a consequence, a sensor output,  $V_B'$ , generated as a result of  $\bar{B}_{RA}$ ,  $\bar{B}_{RC}$ , and  $\bar{B}_{RN}$ , direct linkage to the sensor could be misinterpreted through use of Equation 5 as a current along the LSO. Even if direct linkage of fields can be ignored, complications arise. During lightning attachment to the LSO, the direct

strike current will be modified by LSO surface induced currents and by resonances, as indicated in Figure 9. Surface induced currents are produced as a result of LSO immersion in exterior electromagnetic fields, including the  $\bar{B}_{RA}$ ,  $\bar{B}_{RN}$ , and  $\bar{B}_{RC}$  fields considered earlier. Resonances occur because of the impedance mismatch between the LSO surface and the surrounding environment.

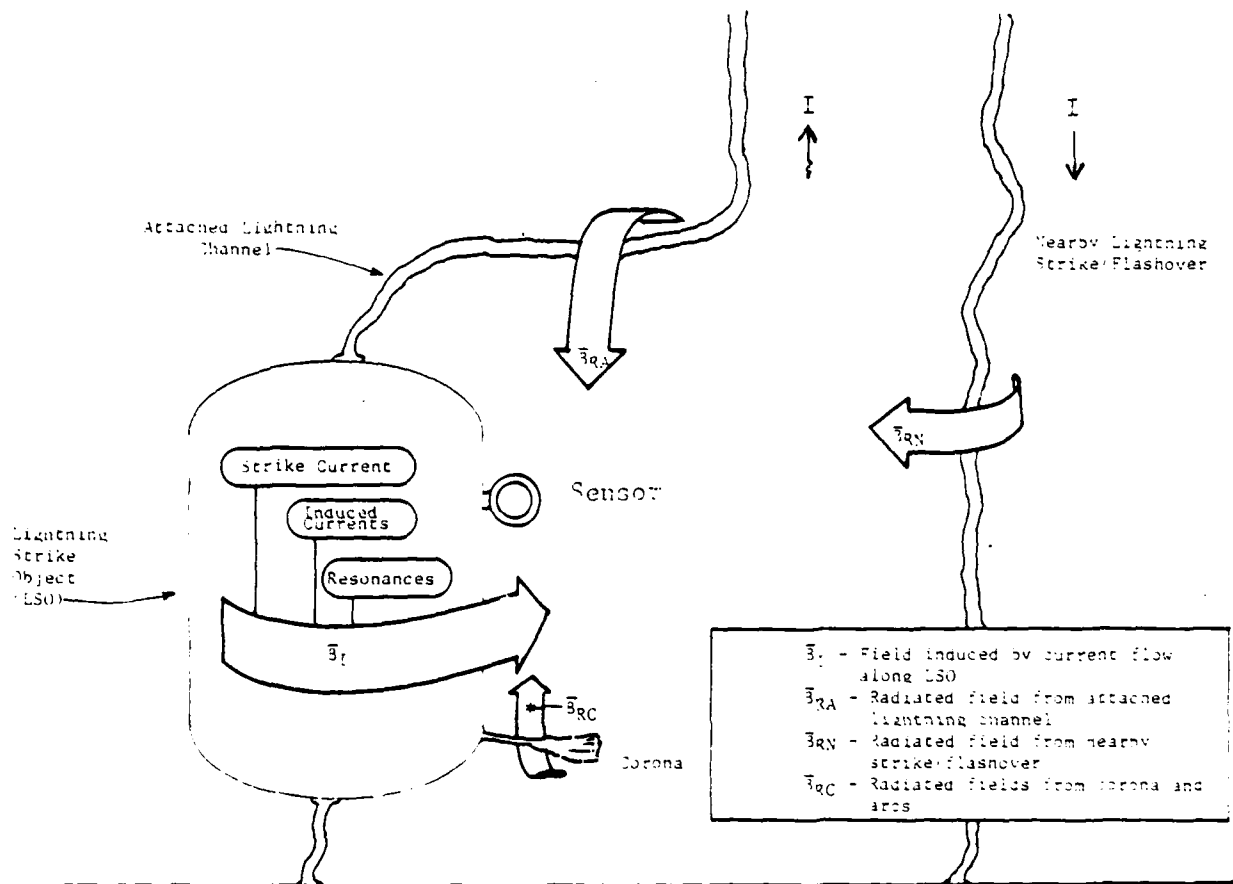

Figure 9. Fields Detected by B-Dot Sensor

Given all the various factors, a single influence, such as the attached lightning channel current, can be extracted from the data only with difficulty. Similar problems in the examination of data persist, but are not discussed, for each of the remaining LSO sensor types described in the following paragraphs.

b. Electric Field

Information on the electric field perpendicular to the LSO surface is provided by Flush Dipole (FPD) sensors which are installed 180 degrees around the LSO circumference from each magnetic field sensor. The sensors used have specifications identical to the FPD-2, which is described on EG&G Data Sheet 1116 and which appears in the appendix of this report. The sensors differ from the standard FPD-2, however, in that the plate is curved to match the radius of the LSO. The sensor output,  $V_E$ , is given by the following equation, based on relationships presented in the EG&G Data Sheet:

$$V_E = RA'_{eq} \epsilon_0 \frac{dE_n}{dt} \quad (6)$$

where

$R$  = sensor characteristic load impedance (50 ohms),

$A'_{eq}$  = sensor equivalent area ( $2 \times 10^{-2} \text{m}^2$ ),

$\epsilon_0$  = permittivity constant ( $8.85 \times 10^{-12}$  farad/meter)

and

$E_n$  = magnitude of the electric field normal to the sensor ground plate (in volts/meter)

The electric field  $E_n$  may be produced by a charge on the LSO surface or by nearby field sources such as lightning channels, flashovers, arcs and corona. The electric field,  $E_{ns}$ , due to surface charge may be found by application of Gauss's law:

$$E_{ns} = \frac{q_s}{\epsilon_0}$$

where  $q_s$  is the surface charge density.

Combination of Equations 6 and 7 results in

$$V_E = RA'_{eq} \frac{dq_s}{dt} \quad (3)$$

Integration of Equation 8, and insertion of the numerical values for R and  $A'_{eq}$  results in

$$q_s(t') = \int_0^{t'} V_E(t) dt \quad (9)$$

Use of Equation 9 will provide an estimate of the LSO surface charge density,  $q_s(t')$ , in units of coulombs/m<sup>2</sup> based upon the electric field sensor output,  $V_E(t)$ , in units of volts. It must be emphasized that Equation 9 is valid only if electric field sources external to the LSO can be ignored. The comments in paragraph 5a concerning caution necessary in data analysis apply as fully to electric field data as to magnetic field data.

#### c. Surface Current

One slot antenna sensor for the measurement of transient current on the exterior surface of the LSO was constructed in-house. This sensor was built into an aluminum sheet access panel for installation near the mid-point of the LSO. The sensor, shown in Figure 10, was tested briefly in the laboratory, but was not installed on the LSO during triggered-lightning field tests. During the field tests, the sensor was removed and the resultant LSO opening was covered with an aluminum panel. The primary reason that the sensor was not used in the triggered-lightning experiment was that the ability of the sensor to withstand extremely high current was unknown. Use of the sensor in 1982 field tests is expected if laboratory tests indicate proper operation under high-voltage/high-current conditions. Specifications and engineering notes on the slot sensor are presented in Appendix C of this report.

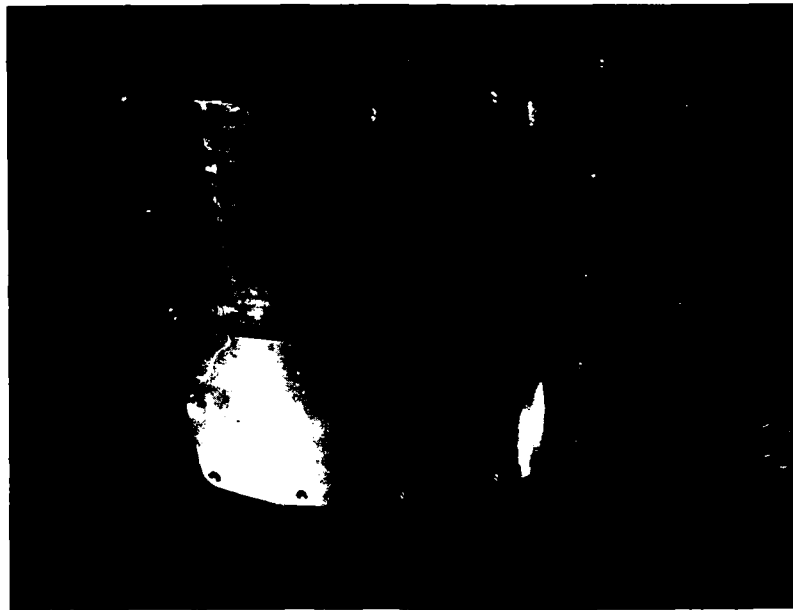

Figure 10. Slot Sensor

## d. Total Strike Current

A Pearson Model 301x current transformer (CT) was mounted on the lower LSO pipe extender during the early part of the program to measure the total current through the LSO. A short length of Belden 9222 triaxial (double-shielded) cable was routed from the CT output, through a small entry port at the base of the LSO and into the LSO data transmitting system. The two outer conductors of the triaxial cable were electrically connected at each end to serve as a common shield for the inner conductor. This configuration evidently provided inadequate surge protection, since the cable was blown from the CT connector during one of the earlier triggered lightning strikes to the LSO. Following the cable severance, the CT was removed from the LSO pipe extender, and the data channel was allocated to a different sensor.

Figure 11 is a photograph of the CT taken shortly after the cable was blown. In that photograph, the loose cable can be seen extending to the left of the square-shaped CT.

A description and specifications of the Pearson 301x current transformer appears in Appendix D of this report.

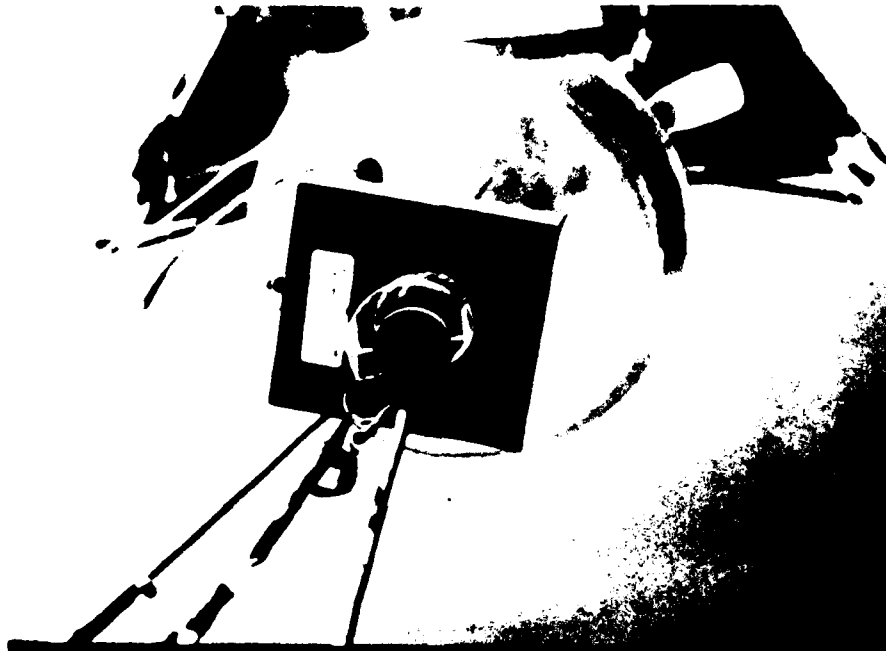

Figure 11. Current Transformer

e. Interior Induced Current

To provide information on induced currents, a wire pair is installed along the full length of the LSO interior positioned along the longitudinal center axis. The wire pair system consists of a standard 300 ohm parallel wire television antenna twinlead and a variable termination selector. The selector, mounted on the upper end of the LSO interior, enables termination options of open circuit, short circuit, 50 ohms, 100 ohms, or 300 ohms. A drawing of the wire pair system showing the major components is presented in Figure 12.

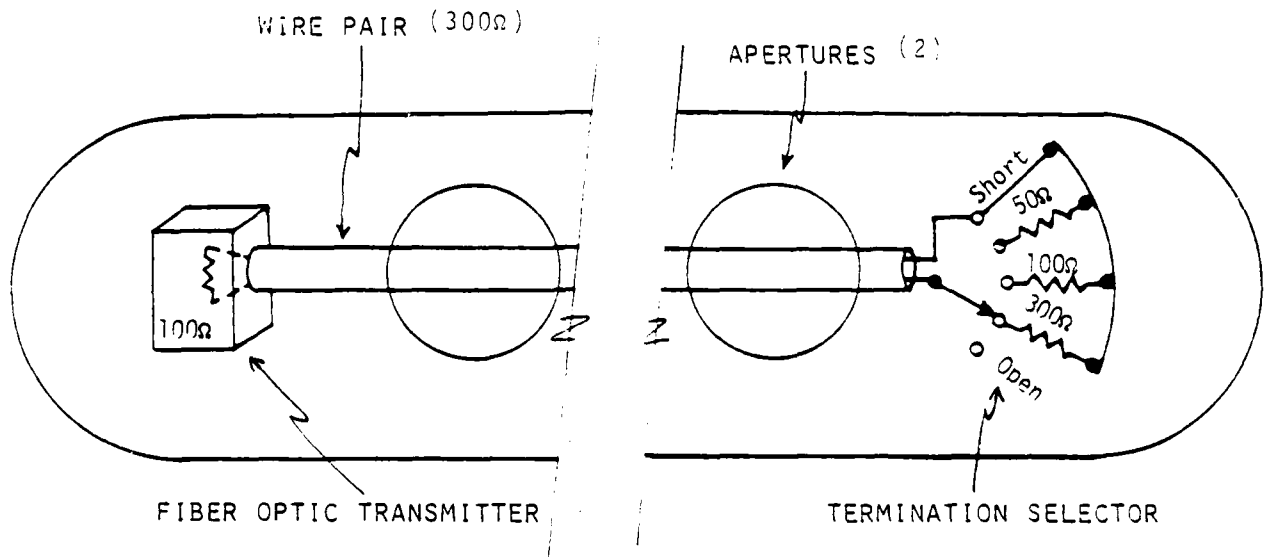

Figure 12. Wire Pair System

The magnitude of interior induced current is dependent upon the size, location and material of apertures through which electromagnetic energy can penetrate. To investigate aperture dependence of induced current, two apertures built into the LSO may be left open, closed with aluminum panel or covered with composite panels. The apertures are circular in shape with a radius of 0.128 meters and are located approximately 0.6 meters from each LSO end. The panel selected for a given aperture is bolted in place with eight standard military aircraft hardware screws spaced evenly around the cover perimeter.

For the duration of the 1981 field tests, the short-circuit wire pair termination option was selected and the uppermost aperture was covered with an aluminum panel. The lower aperture was tested under all three configurations: aluminum, open and composite. The composite panel was fabricated from  $(0 + 45 - 45 90)^S$  graphite-epoxy sheeting.

## 6. DATA TRANSMITTING AND RECORDING SYSTEM

The data transmitting and recording system employed during the 1981 tests is shown schematically in Figure 13. As can be seen from the schematic, any six of the available nine sensors could be chosen for data transmission during a given triggering event. Data from the selected sensors was transmitted from the LSO to the instrumentation van over a fiber optic system consisting of six Meret MDL27802 transmitter/receiver pairs and a bundle of six Meret SDM fiber optic cables. Logarithmic amplifier circuits were used to compress the LSO sensor output signals, expected to reach over 1000 volts during a full strike, to the  $\pm 1$  volt operating range of the fiber optic transmitters. Logarithmic amplifiers, rather than resistive dividers, were used for the attenuation to enable data acquisition over a wide range of voltage levels and to insure system protection in the event of an unexpectedly high voltage surge. Compensation for signal loss resulting from transmittal over the fiber optic cables was accomplished with follow-on amplifiers in the instrumentation van.

Data received at the instrumentation van could be patched in any order to six available recorders: four Biomation 6108 transient digitizers and two Hewlett-Packard 1744A storage oscilloscopes. Any one of the six data channels could be selected to trigger the entire data recording system at a signal voltage level preset in a comparator trigger circuit. Data routed to the Bio-mation recorders was first fed through antialiasing filters to eliminate waveform component frequencies exceeding the sample-rate capability of the Biomations. Waveforms stored in the Biomation units were displayed on a Tektronix 5103N/D12 dual-beam oscilloscope for the acquisition of a photographic record and were fed to a chart recorder for additional, more detailed, hard copies. Such recordings could be made both before and after waveform input to an integrator. Waveforms captured by the 1744A were photographed directly from the 1744A screen. The data transmitting and recording bandwidth was limited by the fiber optic system to 20 megahertz and by the Biomation units to 2 megahertz. Specification sheets on key system components are consolidated in Appendix E.

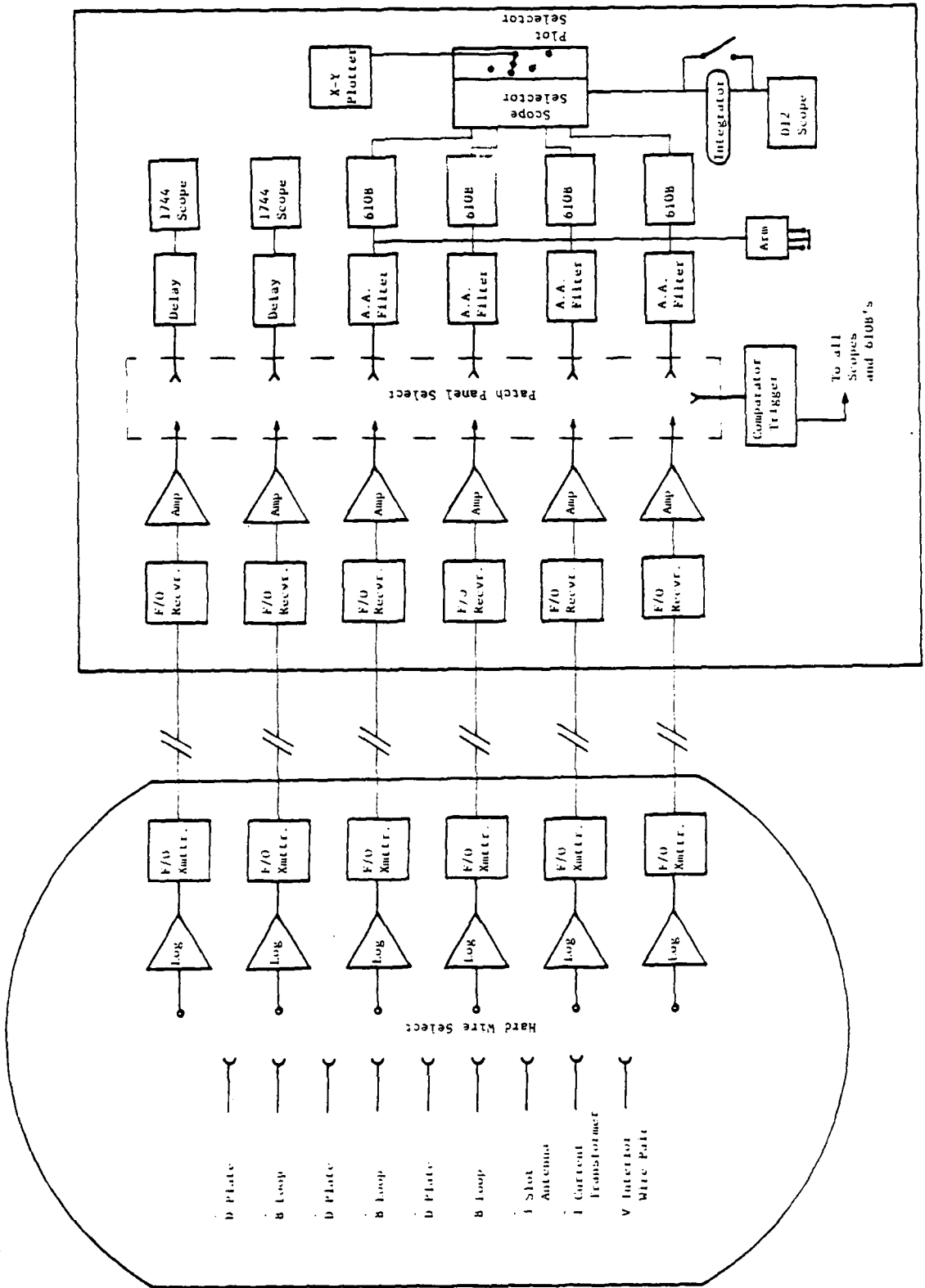

INSTRUMENTATION VAN

LIGHTNING STRIKE OBJECT (LSO)

Figure 13. Data Transmitting and Recording System

## 7. DATA SYSTEM LIMITATIONS

Several limitations in the data recording system greatly affected the type and quality of data which could be collected during the 1981 program. These limitations ensued primarily from a decision early in the program to limit resources to the minimum required for determination of the testing concept feasibility. A highly sophisticated lightning data recording system used in the FDL Airborne Lightning Characterization Program was known to be available for a potential 1982 RTLI effort, should the feasibility prove favorable. Rather than invest in a second state of the art system for the 1981 RTLI program, standard recording units available in the Laboratory were used. Although these units were fully sufficient for a concept feasibility investigation, they did not possess the simultaneous fast-response and large memory capabilities required for the acquisition of high-quality lightning data. Specific consequences of the 1981 data system limitations are outlined in the paragraphs which follow.

### a. Time Window Limitations

A particularly significant impact of the restricted available memory was an inability to record the full history of a triggered event (on the order of seconds in duration) while simultaneously recording fine structure (on the order of microseconds in duration). Since the selection of large time windows produced data having very poor resolution, recorders were generally set for short time windows during the 1981 field tests. This selection was made, however, at the sacrifice of full-history data which would enable determination as to whether the recorded waveforms were due to pre-strike streamering, the initial current along the triggering wire, the first lightning return stroke, a subsequent return stroke or some other event. The time window problem was further complicated by the fact that the electric and magnetic field sensors were responsive to field derivatives rather than the actual fields. On those occasions when these sensors were chosen for a system trigger, a very low but fast rising prestrike corona or stepped leader discharge could turn the instrumentation on, and the recording interval could be over before the beginning of a main lightning stroke. Because of the time window limitation, no means were available for identifying such events or for

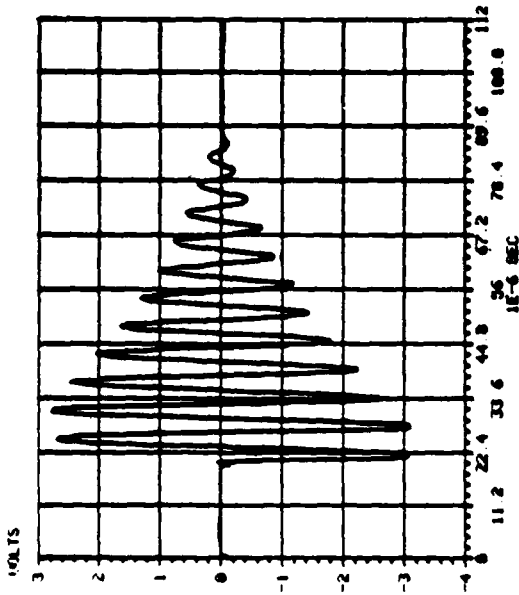

a. Injected Laboratory Waveform as Measured by Current Transformer

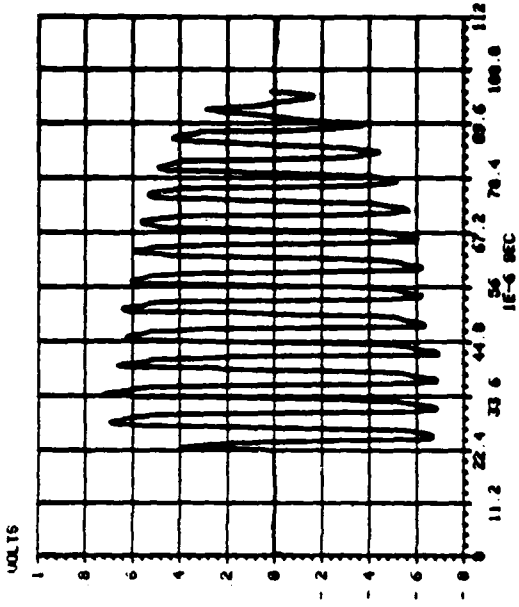

b. Waveform Received at B-Dot Sensor Recorder

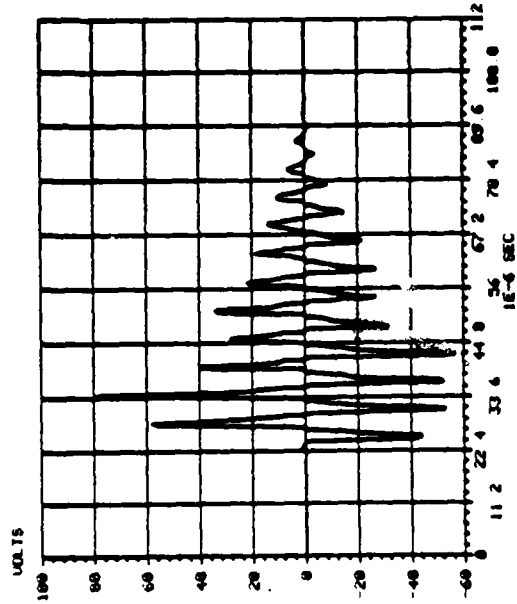

c. Antilog of Figure 15b Waveform

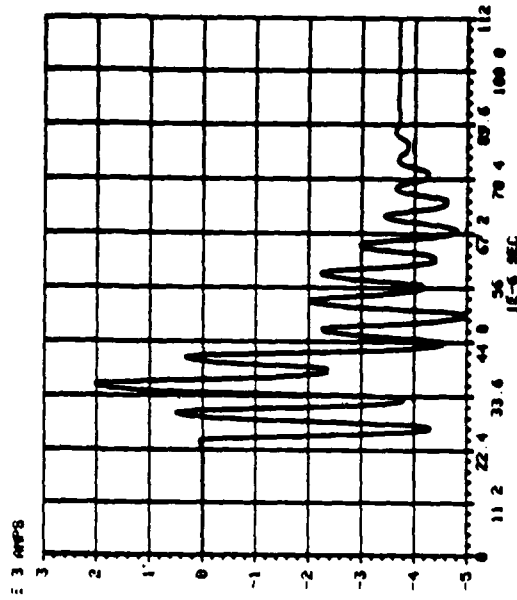

d. Injected Laboratory Waveform as Predicted from B-Dot Data

Figure 14. Waveform Processing Example

establishing whether the data as a whole is representative of a full threat posed by triggered lightning strikes.

b. Data Processing Limitations

Processes required to retrieve and analyze recorded waveforms further affected the quality of the data which was acquired. Most of the data was stored in the form of oscillograph photographs. Analysis of these records required that the photographs be manually traced for input into a computer. Since most of the waveforms were collected at the high speed limit of the oscilloscopes, the resultant photographs were faint and difficult to trace with accuracy. The problem was further exacerbated by the fact that the data signals were passed through logarithmic amplifiers prior to reaching the oscilloscopes. Consequently, small errors in tracing could lead to order-of-magnitude errors during the computerized antilog process.

Figure 14, which shows a waveform at various stages of processing, illustrates the processing sequence and the resultant data degradation for a typical waveform. The damped oscillating waveform of a current pulse injected into one end of the LSO during laboratory testing is shown in Figure 14a. This waveform is the output of a current transformer placed at the injection point, and, except for a scaling factor, represents the actual current along the LSO. The oscillation frequency is that of the combined LSO-pulse generator system. Figure 14b illustrates the corresponding waveform from an LSO B-dot sensor after transmittal to the recording system. Recovery of the true B-dot sensor output requires that the antilog of Figure 14b be taken, using the logarithmic calibration curve for the data channel over which the transmission occurred. Computer application of this antilog process results in the waveform shown in Figure 14c. Use of Equation 5 from Section 5a of this report on Figure 14c produces the waveform shown in Figure 14d. The Figure 14d waveform is the predicted current along the LSO based upon the output of the B-dot sensor. Thus the waveforms in Figures 14a and 14d should be identical. The obvious differences between the two illustrates the degree to which the data could be degraded as a result of processing. Since input functions are known in laboratory testing, obvious processing errors in laboratory waveforms can be deleted and the

AFWAL-TR-83-3031

degradation minimized. Equivalent errors emerging in the processing of triggered lightning data are much more difficult to identify. Consequently, any interpretation of the 1981 Mt Baldy data set must be made with extreme caution.

## SECTION III

## FIELD TESTS

## 1. PURPOSE OF TESTS

The ultimate goal of the RTLI program is to collect detailed data on triggered lightning and the interaction of triggered lightning with a largely metallic object. The primary aim of the 1981 effort was to experimentally determine, at relatively low cost, the feasibility of the testing concept. Of particular concern was whether triggered lightning could be reliably and repeatedly directed nearby or onto the LSO. A related question was whether the lightning could be prevented from tracking down the Scaffold structure or the LSO supporting cables rather than across the isolation air gaps to the LSO as desired. The ability of the LSO and the LSO instrumentation to survive repeated direct lightning strikes was also of concern. Instrumentation requiring "proof by fire" testing included the sensors, the multi-channel triggering circuitry, the fiber optic transmitting system and the data recording system. Acquisition of data on triggered lightning characteristics was also highly desired. Because of limited capabilities of the recording units, however, the collection of high quality data was not anticipated.

## 2. TEST CONFIGURATION

The hardware for the Mt Baldy field tests was shown earlier in Figure 2 and is described in Section II. During the morning of each day, a testing configuration of the LSO was selected and operational checks of the equipment were made. Selection of a test configuration required an identification of the six sensors on the LSO to be connected to the fiber optic transmitting system, setting of recorder time windows, setting of a system triggering level and setting of LSO-Scaffold air-gap distances. The recorders were generally set at or near maximum operating speed, corresponding to full-screen time windows of 25.6 microseconds for the Biomation units and 1.0 microseconds for the 1744A oscilloscopes. Short time windows were chosen to acquire maximum resolution of signal fine structure, particularly risetime. As discussed in the previous section, instrumentation capable of high-resolution recording of an

entire triggered lightning flash, on the order of seconds in duration, was not available for the 1981 program. Each of the LSO exterior sensor types, B-dot, D-dot and current transformer, were used to provide a recording system trigger over the course of the Mt Baldy experiment, and the comparator trigger threshold level was varied widely. The air gaps - one between the Scaffold and the top of the LSO and the other between the grounded French current shunt cage and the bottom of the LSO - were set by altering the LSO distance above ground and/or changing the length of pipe extenders on each end of the LSO. Over the course of the program, air gap distances ranging between one-half and zero meters (grounding strap across gaps) were tested. All of the sensors available for the LSO were tested except for the slot antenna.

Triggered lightning tests were performed in the afternoon or evening during periods of thunderstorms in the Mt Baldy region. During thunderstorms, cloud-to-ground electric fields were monitored by the French rocket team for conditions favorable for a triggering event. When such conditions arose, an announcement was made and a launch shortly followed. If a strike was triggered and successfully recorded on the RTLI instrumentation, hard copies of the captured waveforms were made. The RTLI instrumentation was then cleared and rearmed for the next attempt. Three to five minutes were required to make hard copies. Consequently, on those occasions when two triggerings were accomplished in quick succession, only the first was recorded. Processing equipment required to antilog and integrate the waveforms was not available at the Mt Baldy test site. Data was thus stored for later processing at the Wright-Patterson Air Force Base facility.

### 3. TEST RESULTS

A total of 42 lightning strikes were triggered during the 1981 thunderstorm season atop Mt Baldy. Photographic records show that, in several instances, strokes initially triggered by a ground rocket arced from the triggering wire to the Scaffold or to the LSO for some of most of the restrikes. No evidence of tracking by triggered lightning strikes down the Scaffold legs or along the dielectric support cables can be seen in photographic records. Typical strikes, photographed with an

open-shutter 35mm camera, are shown in Figures 15 through 18. The photographs in Figures 16 and 17 were provided by Mr Ray Nelson, a freelance photographer, and may not be used without his permission. Figure 15 was provided by the New Mexico Institute of Mining and Technology (NMIMT), a supporting contractor for this effort. Figure 18 was photographed by an Air Force camera at the instrumentation van. Successive lightning restrikes, blown laterally by the prevailing wind, are clearly visible in most of the photographs taken at close range to the LSO Scaffold.

A summary of the triggerings is presented in the NMIMT technical report on the program, appearing in Appendix F. The NMIMT report may also be referred to for additional information pertaining to the test configuration; particularly on the Scaffold construction and the French wire-and-rocket triggering system. Fourteen pages of electric field meter data included in the original NMIMT report are omitted.

The only equipment damaged by the triggered strikes was a triaxial cable from the LSO current transformer (CT) to the LSO interior. This cable, partially exposed at the LSO exterior, was severed at the CT connector during an attached triggered lightning event (Figure 11). All of the remaining LSO instrumentation continued to function during the event and thereafter.

An LSO data set consisting of approximately 90 waveforms of varying quality was acquired during the Mt Baldy experiment. Waveforms of good quality (within the constraints of the recording system capability) were received from all of the sensors on the LSO over the course of the program, with the exception of the lowermost D-dot sensor, which was never patched to the recording system. Good wire pair waveforms were received with the lower aperture open and with the aperture covered with a composite panel. No wire pair waveforms were generated when the aperture was covered with the aluminum panel; however, this configuration was used in only a small number of triggered lightning events early in the testing period. The uppermost 3-dot sensor output was used as the instrumentation trigger for the most of the recordings, although the CT was also employed for successful triggerings early in the program and a D-dot sensor was used for one trigger. Most of the better waveforms

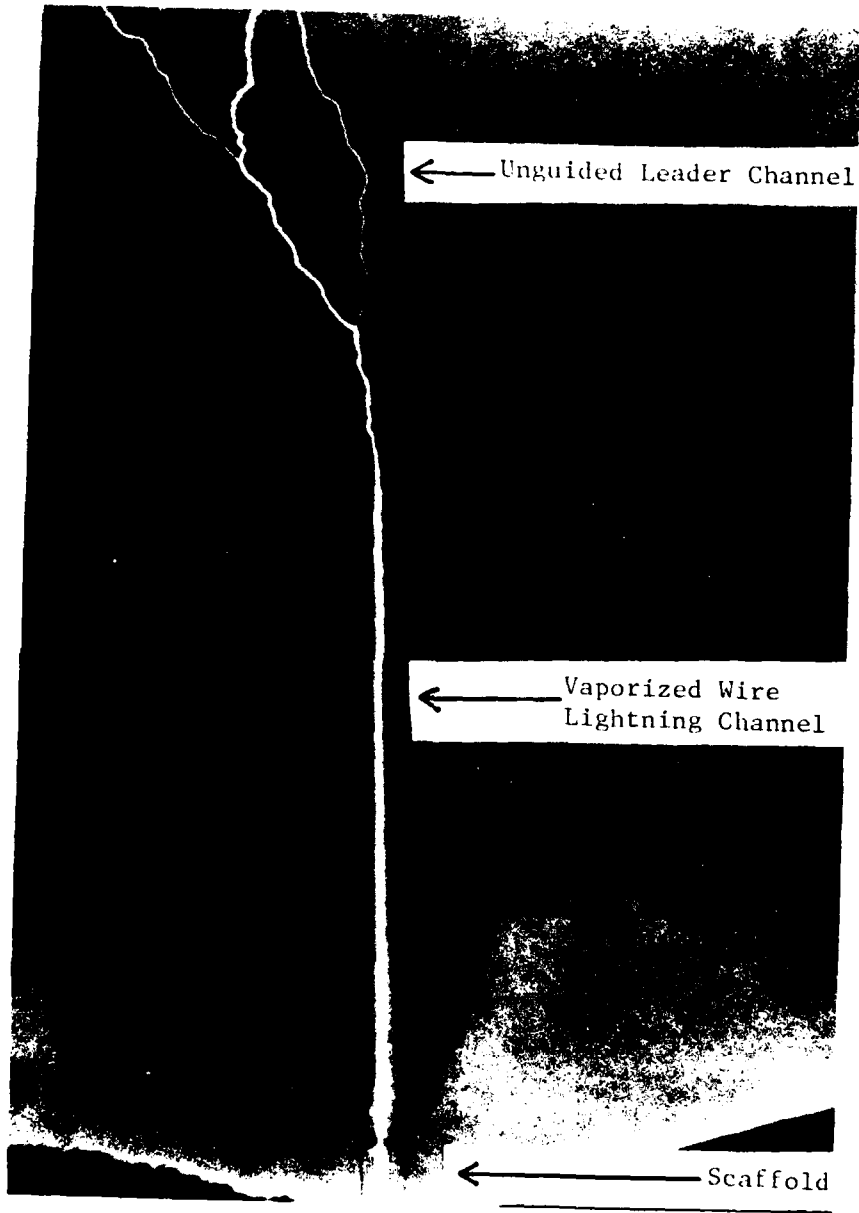

Figure 15. Distant Views of Rocket-Triggered Lightning Strikes

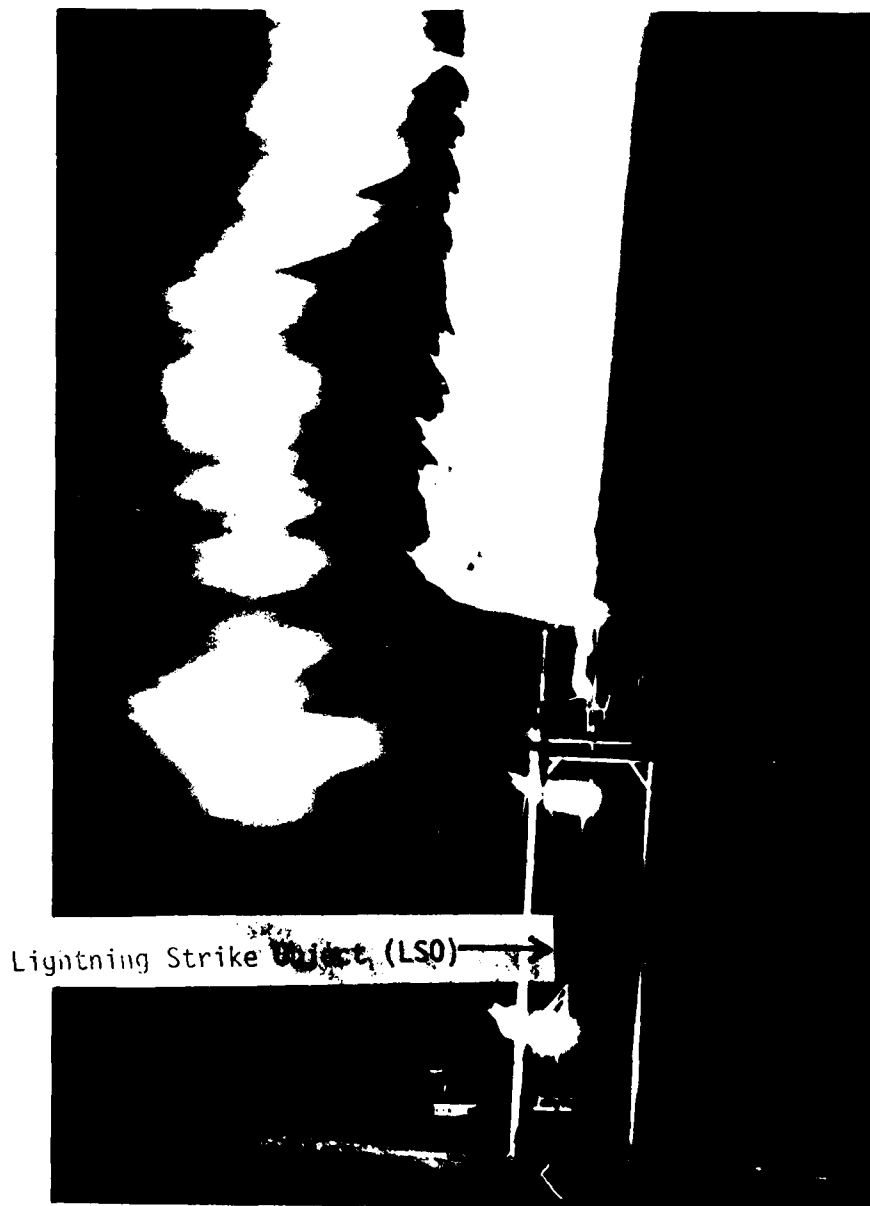

Figure 16. Nearby Views of Rocket-Triggered Lightning Strikes

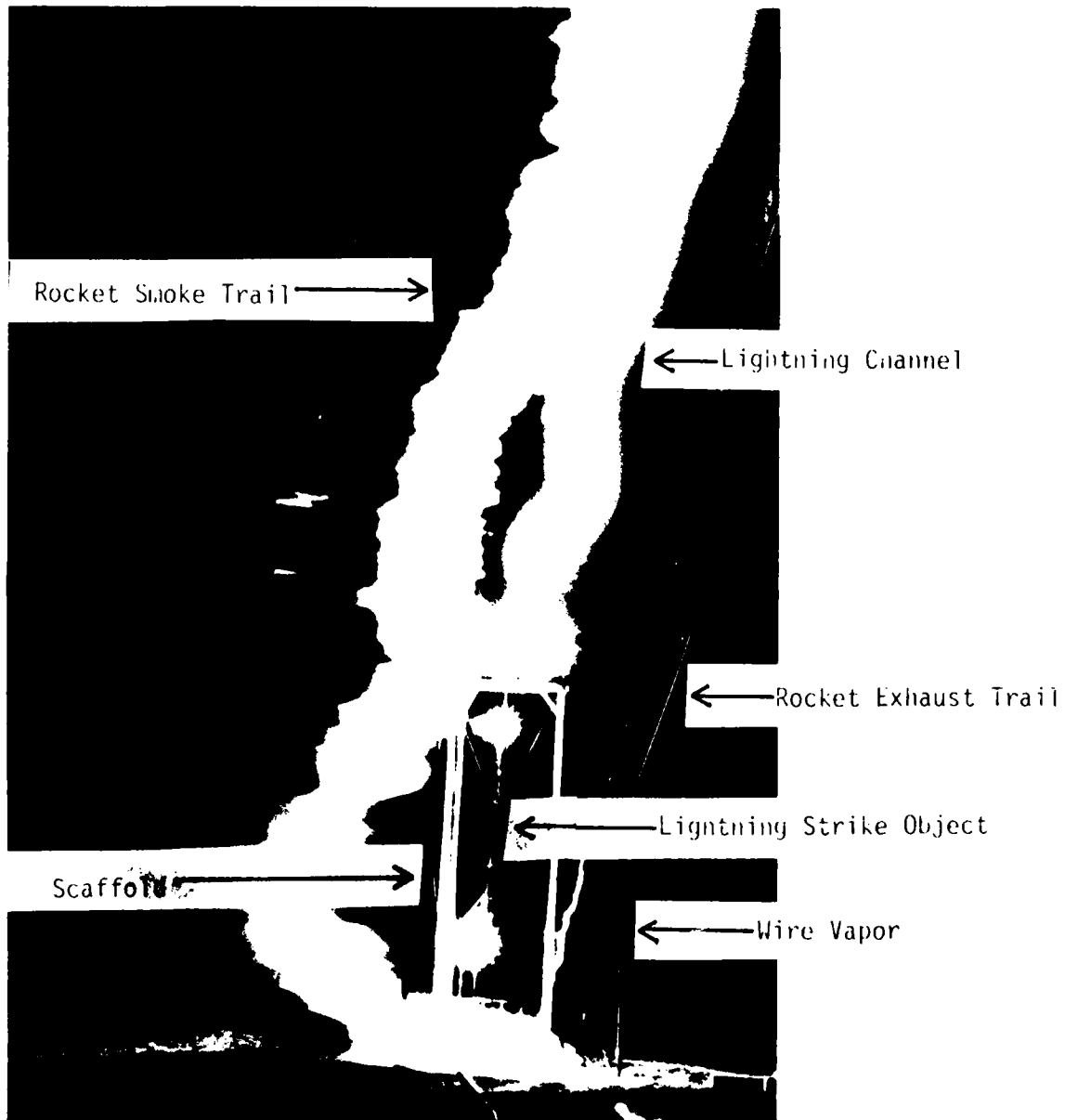

Figure 17. High Detail View of Rocket-Triggered Lightning Strike



Figure 18. Rocket-Triggered Lightning Strike Photographed from Air Force Instrumentation Van

were acquired with the comparator trigger level around 700 millivolts - approximately three-quarters of maximum value. The largest air gaps bridged by a triggered lightning strike to the LSO were 58 centimeters at the top and 63 centimeters at the bottom. These were the largest air gaps set during the program.

Selected unprocessed waveforms illustrated in Figures 19 through 23 show the quality of data attainable with the 1981 system. Figure 19 shows waveforms received during a lightning strike triggered by a ground-launched rocket at 13:43:13 Mountain Standard Time (MST). In each oscillograph of Figure 19, the upper trace is the signal stored by a Biomation digitizer, as displayed on an oscilloscope. The lower trace is the corresponding waveform generated after passage through an integrator. It must be emphasized that the upper trace is a logarithmic function of the actual signal generated by the sensor, since the data was fed through logarithmic amplifiers before transmittal to the instrumentation van. The lower trace is an integral of the upper trace, and consequently does not represent a true integration of the sensor output. To obtain the actual sensor output integral (for use in equations presented in Section II), the upper traces must first undergo an antilog process, requiring computers which were not on hand at the Mt Baldy test site. Disregarding this complication, a comparison of Figures 19a and 19b reveals that the waveform from the upper B-dot sensor is very similar to the waveform from the lower B-dot sensor, except for an inversion. In addition, the output of the wire pair, Figure 19d, bears a close resemblance (in this particular triggering) to the waveform from the center D-dot sensor, Figure 19c. An enlargement of the wire pair waveform generated by the X-Y plotter is shown in Figure 20. The same waveform, as recorded independently by the 1744A storage oscilloscope, is shown in the inset of Figure 20.

A similar series of waveforms produced by a TIPSy rocket triggering at 13:47:52 on the same date is presented in Figures 21 and 22.

Figure 23 shows waveforms resulting from a lightning flash triggered at 13:37:20 by a rocket launched from the top of the Scaffold, also on 14 August. It is interesting to note that, in this triggering, the waveforms from the upper and lower B-dot sensors are in phase; i.e., no

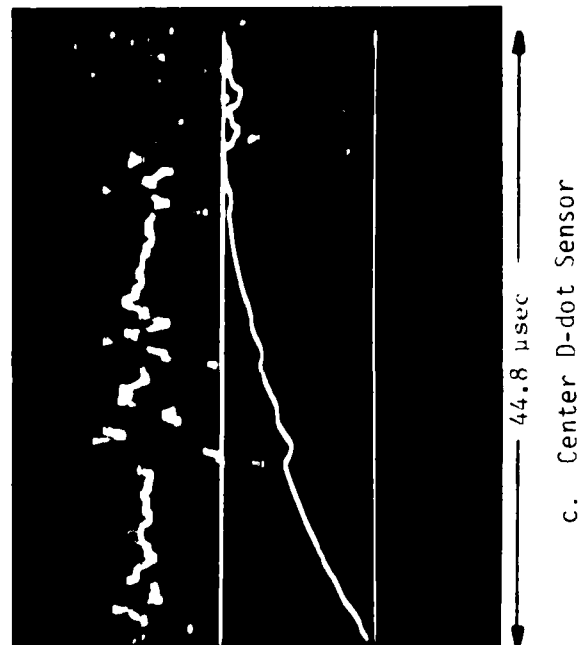
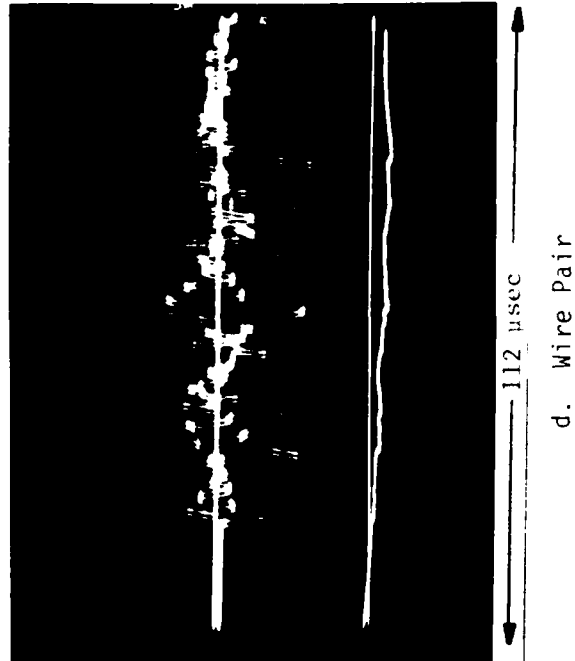
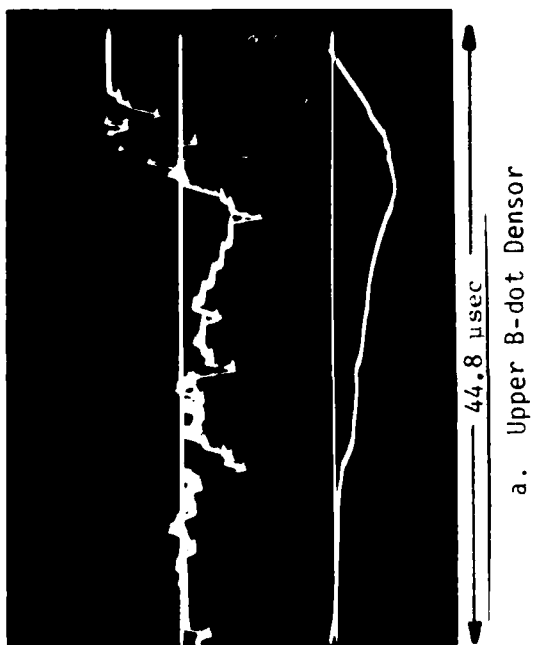
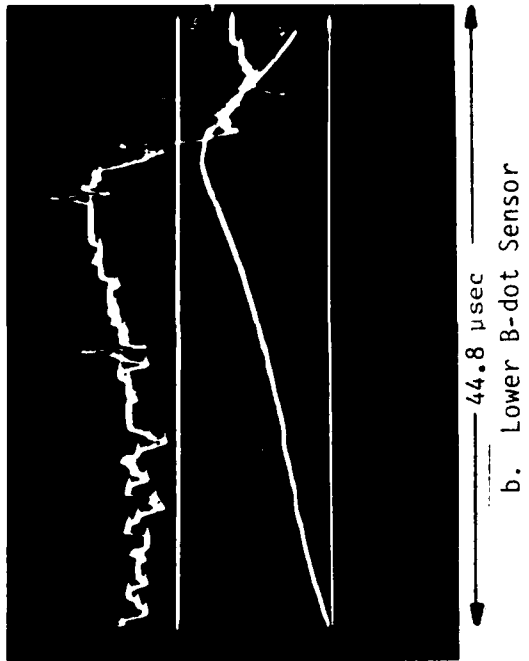

Figure 19. Unprocessed LSO Data from Lightning Strike of  
14 August 1981, 13:43:13 MST

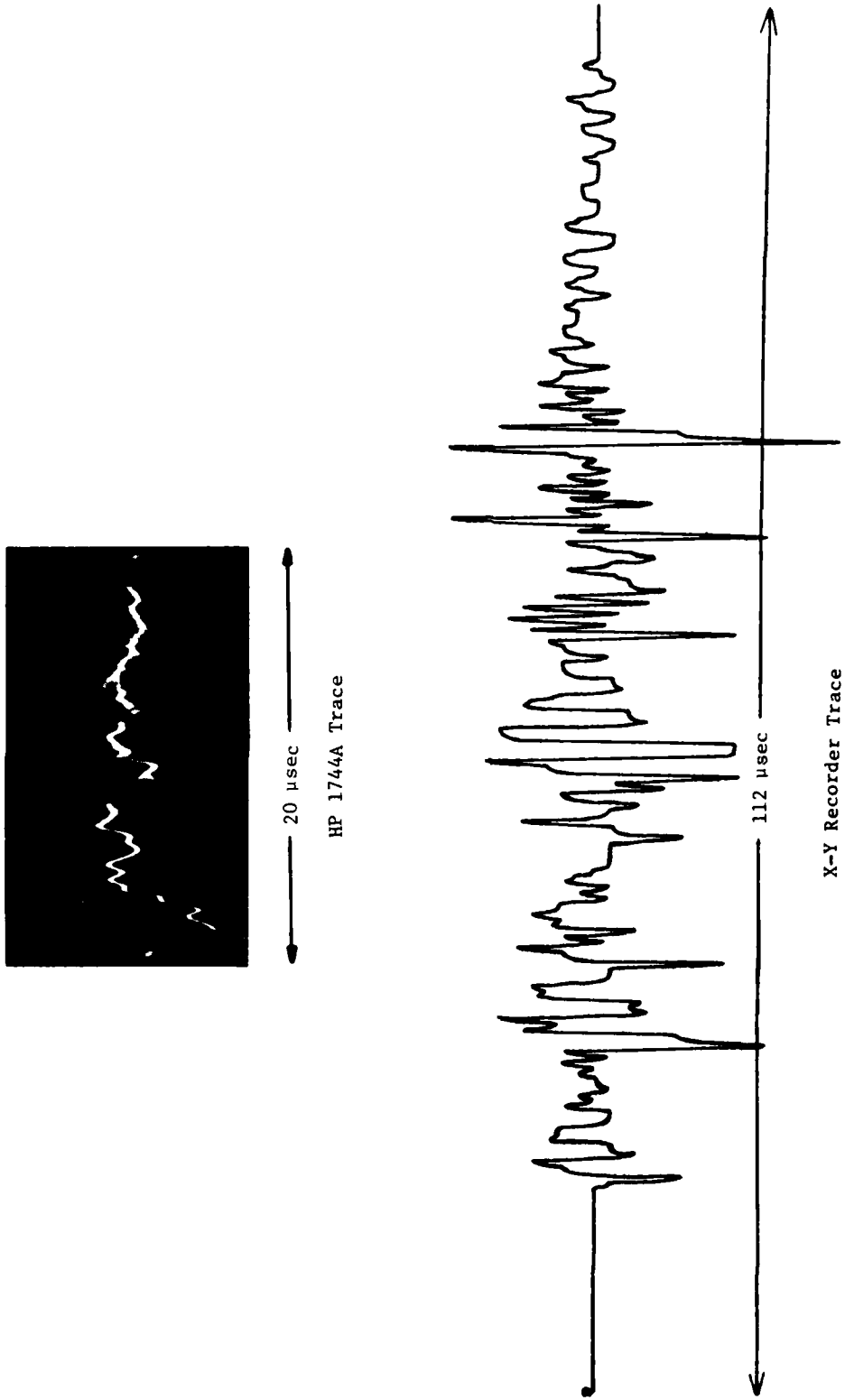

Figure 20. Wire Pair Waveform from Lightning Strike of 14 August 1981, 13:43:13 MST

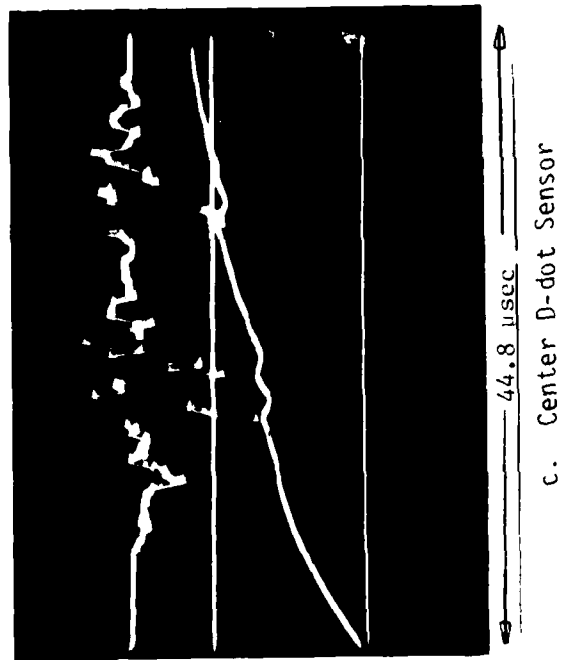
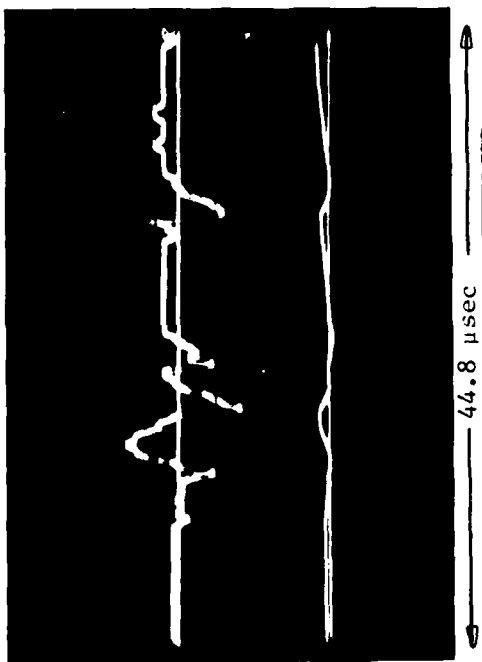
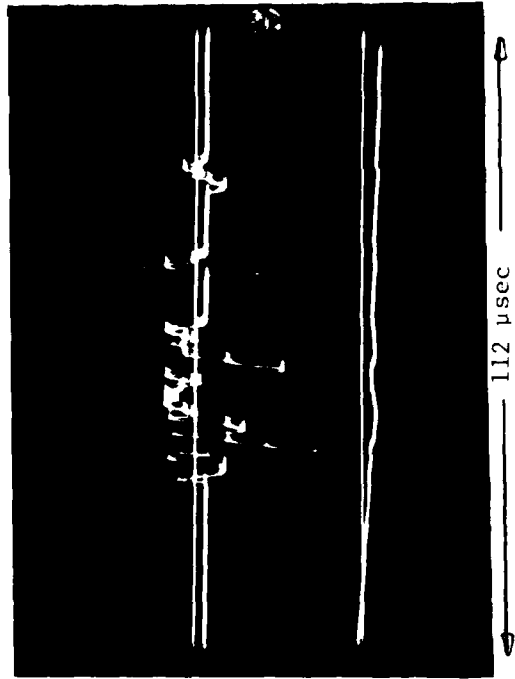
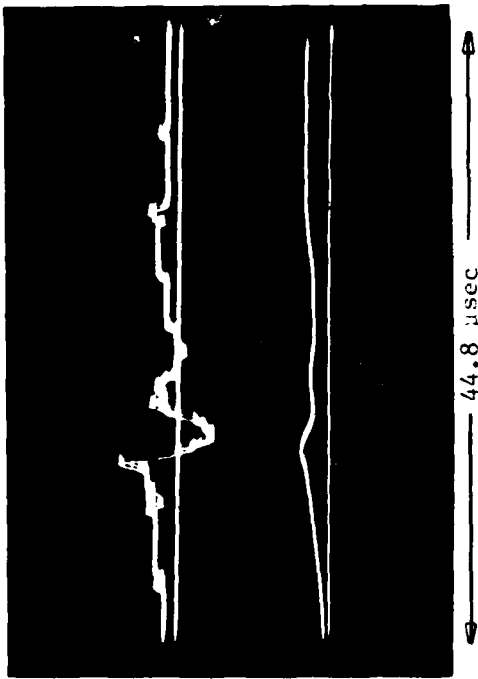

Figure 21. Unprocessed LSO Data from Lightning Strike of  
14 August 1981, 13:47:52 MST

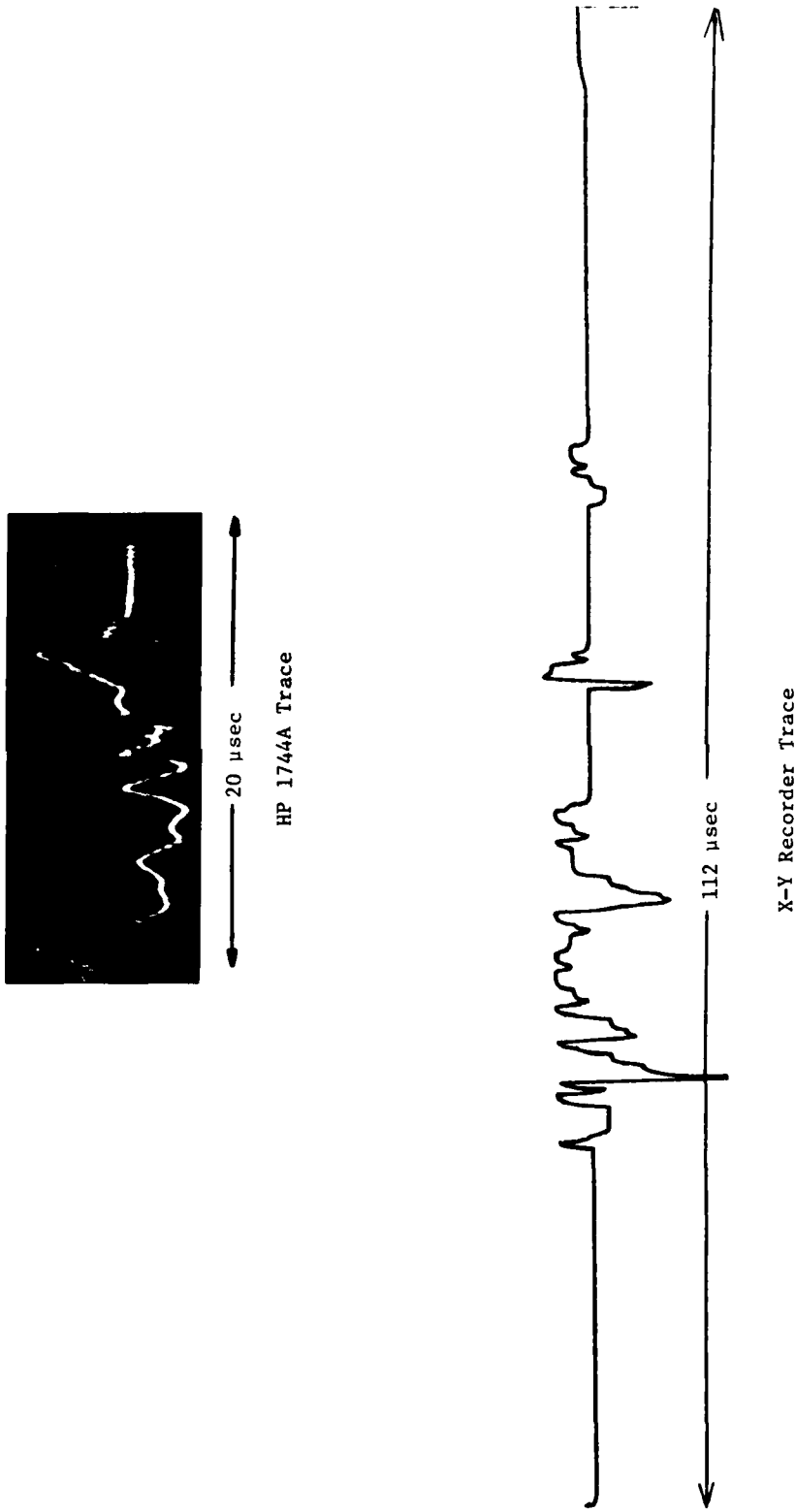

Figure 22. Wire Pair Waveform from Lightning Strike of  
14 August 1981, 13:47:52 MST

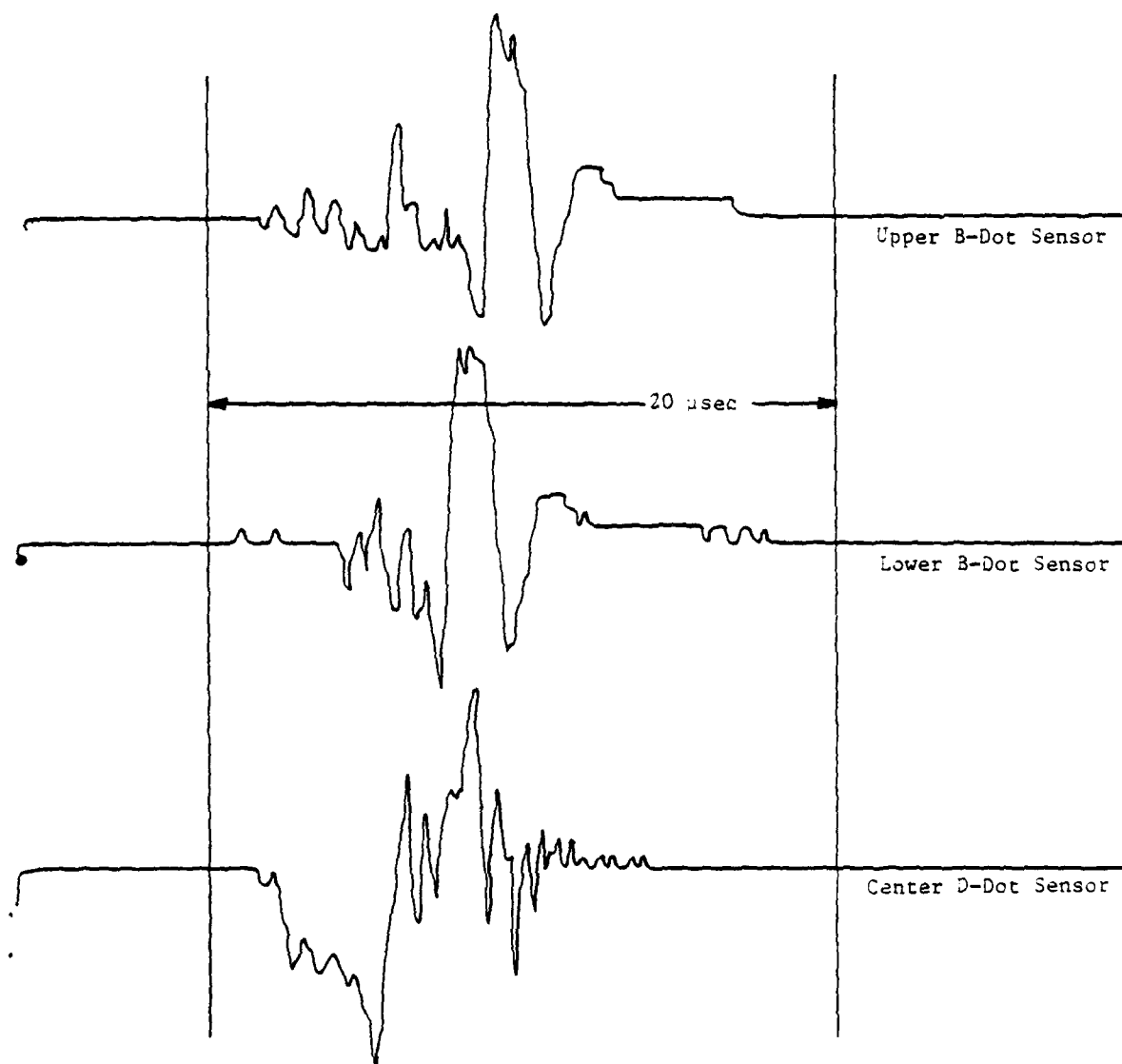

Figure 23. Unprocessed Waveform from Lightning Strike of  
14 August 1981, 13:37:20 MST

inversion occurs. This is in contrast with the triggerings of 13:43:13 (Figure 19) and 13:47:52 (Figure 21), in which the waveform from the upper B-dot sensor is an inversion of the waveform from the lower B-dot sensor. A possible physical explanation of the difference is that the waveforms from the 13:37:20 triggering could be due to current flow along the LSO, and the waveforms from the 13:43:13 and 13:47:52 triggerings due to radiated fields from nearby lightning channels. As can be seen in Figure 24, the two situations can produce sensor polarity differences if the B-dot sensors are on opposite sides of the LSO circumference (as is the case for the upper and lower B-dot sensors) and if the two sensors and the lightning channel are in a common plane. Having made this explanation, however, it must be pointed out that in the full 1981 Mt Baldy data set, no clear correspondence between B-dot waveform inversion and lightning channel location can be identified. Difficulties in establishing such lightning/waveform interrelationships prevail throughout the 1981 data, and can be for the most part attributed to the recording system limitations discussed in Section II of this report. Because of these limitations, data reduction and analysis was largely restricted to that necessary to identify needed system improvements.

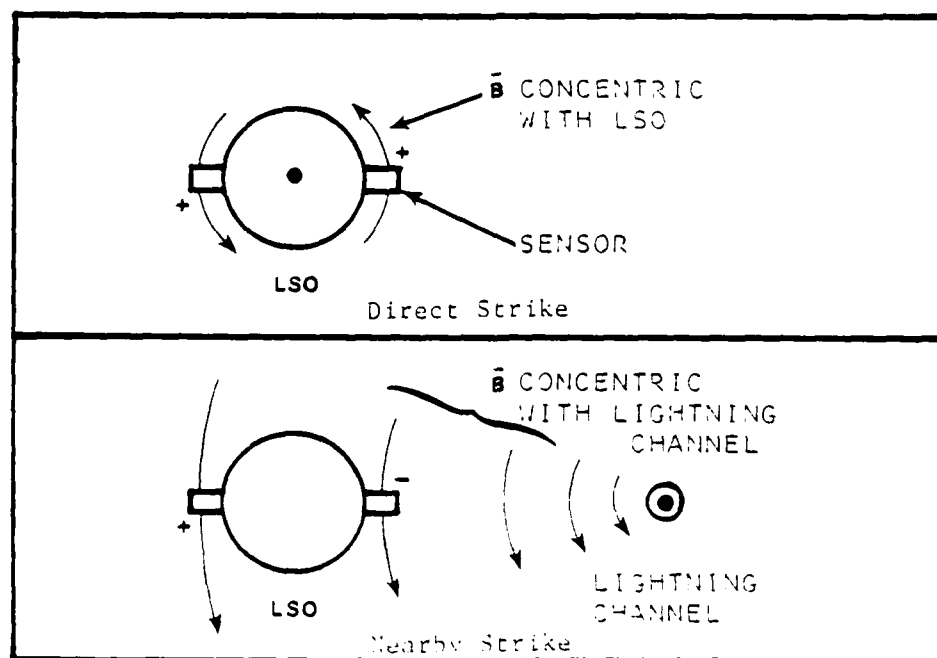

Figure 24. Lightning Magnetic Fields and Sensor Polarities

## SECTION IV

## CONCLUSIONS

From the 1981 RTLI program results, it was concluded that a follow-on 1982 exploratory development effort would be well-justified. This conclusion was based upon the general observations that the systems and hardware developed for the program operated as planned, proving the feasibility of the Rocket-Triggered Lightning testing concept. Specific findings of the 1981 effort, and recommended modifications for improving the system capability are discussed in the paragraphs which follow.

## 1. PROGRAM FINDINGS

The primary finding of the 1981 RTLI program is that lightning-object interaction data can be acquired by directing rocket-triggered lightning strikes to an instrumented target. Through the use of a properly designed wire-and-rocket system, lightning flashes can be reliably guided onto or nearby the desired target object. In an area of high thunderstorm incidence, as in the Mt Baldy region, a large number of such flashes can be triggered over a single season, offering a potential for the acquisition of a large amount of data in a short period of time. Furthermore, the pre-determined location of triggered strikes enables the acquisition of data, such as detailed photographic records, not generally possible by any other means.

A secondary finding of the effort is that no fundamental test system barriers exist which require attention. The prototype system developed for the 1981 tests operated fully as planned and was capable of withstanding repeated direct lightning strikes. Among all the hardware and instrumentation comprising the 1981 system, only one failure occurred over the duration of the testing season: severance of the triaxial cable leading from the LSO body to the current transformer on the pipe extender. This failure in no way impacted the remainder of the system, and can be easily corrected through a simple modification. No damage affecting the integrity of the wooden Lightning Strike Scaffold or the dielectric cables supporting the LSO above ground occurred. Lightning strikes directed to the top of the Scaffold followed the desired path across the two air gaps and through the LSO. Flashes triggered by ground rockets were

somewhat more perverse, in that some attached to the Scaffold or to the LSO during restrikes. This can probably be prevented, if desired, by moving the rocket launch sites farther from the Scaffold base.

## 2. RECOMMENDED SYSTEM MODIFICATIONS

Over the course of the 1981 program, a number of possible system improvements were identified. Some desired modifications, such as an upgrading of the data acquisition system, were recognized from the onset of the effort. Other improvements became apparent from experience gained during test operations. Following are descriptions of recommended modifications which have already been incorporated in the RTLI system, and which will be tested during the 1982 thunderstorm season.

### a. Data Recording System Upgrade

The data recording system has been replaced by the system previously used in the 1981 FDL Airborne Lightning Characterization Program (ALCP). The replacement system consists of a 10-channel digital recorder, a 28-channel analog recorder, and the necessary interface and triggering circuitry. The digital recorder, manufactured by MicroPro, Inc, is capable of digitizing 164 microseconds of data at 350 millisecond intervals with an 8-bit amplitude resolution and a maximum bandwidth of 25 megahertz. The analog recorder, manufactured by Honeywell, will record approximately 15 minutes of 2 megahertz data per standard 9000-foot tape. Ten channels of the Honeywell recorder will be used to store the data dumped from the digital recorder. The remaining channels will be used for a variety of purposes, including the continuous recording of sensor data, storage of timing pulses, voice recording, and recording of data from ground-based electromagnetic sensors. Use of the MicroPro-Honeywell system will provide data of extremely high quality which may be directly compared with data collected in the ALCP program.

### b. Current Transformer Replacement

The Pearson transformer originally on the lower LSO pipe extender has been replaced by an OMM-2 I-dot sensor manufactured by EG&G. A second I-dot sensor has been placed on the upper pipe extender, enabling measurement of current at each end of the LSO. Cables to the I-dot

sensors are on the interior of the pipe extenders, preventing the possibility of burnthrough during direct lightning strikes. The OMM-2 sensor bandwidth exceeds 70 megahertz.

c. Increase of LSO Length

Through the addition of a new center section, the LSO has been extended in length from 8.5 meters to 11.8 meters. This modification decreases the half-wave resonance frequency of the LSO from 17.6 megahertz to 12.7 megahertz. The diminished frequency is more within the capability of the recording system, which should enhance observation of lightning-object interaction phenomena in the electromagnetic data.

d. Improved Photographic System

During the 1981 tests, some of the triggered lightning strikes were photographed with a 35 mm still camera and with a home movie camera. From a review of these photographs, it became evident that high-quality photographic records of each lightning strike could greatly aid in the interpretation of LSO electromagnetic field data. Consequently, two high-speed motion picture cameras have been incorporated in the 1982 RTLI system. The cameras will be stationed at right angles to the Scafold to enable a three-dimensional photographic reconstruction of the lightning propagation path and any corona or streamering from the LSO. Photographs will be made at 10,000 frames per second, and the framing pulses will be recorded on the analog data tape. The two motion picture cameras and a 35 mm camera will be turned on by a single control switch, and the motion picture cameras will automatically cut off after a preset time interval.

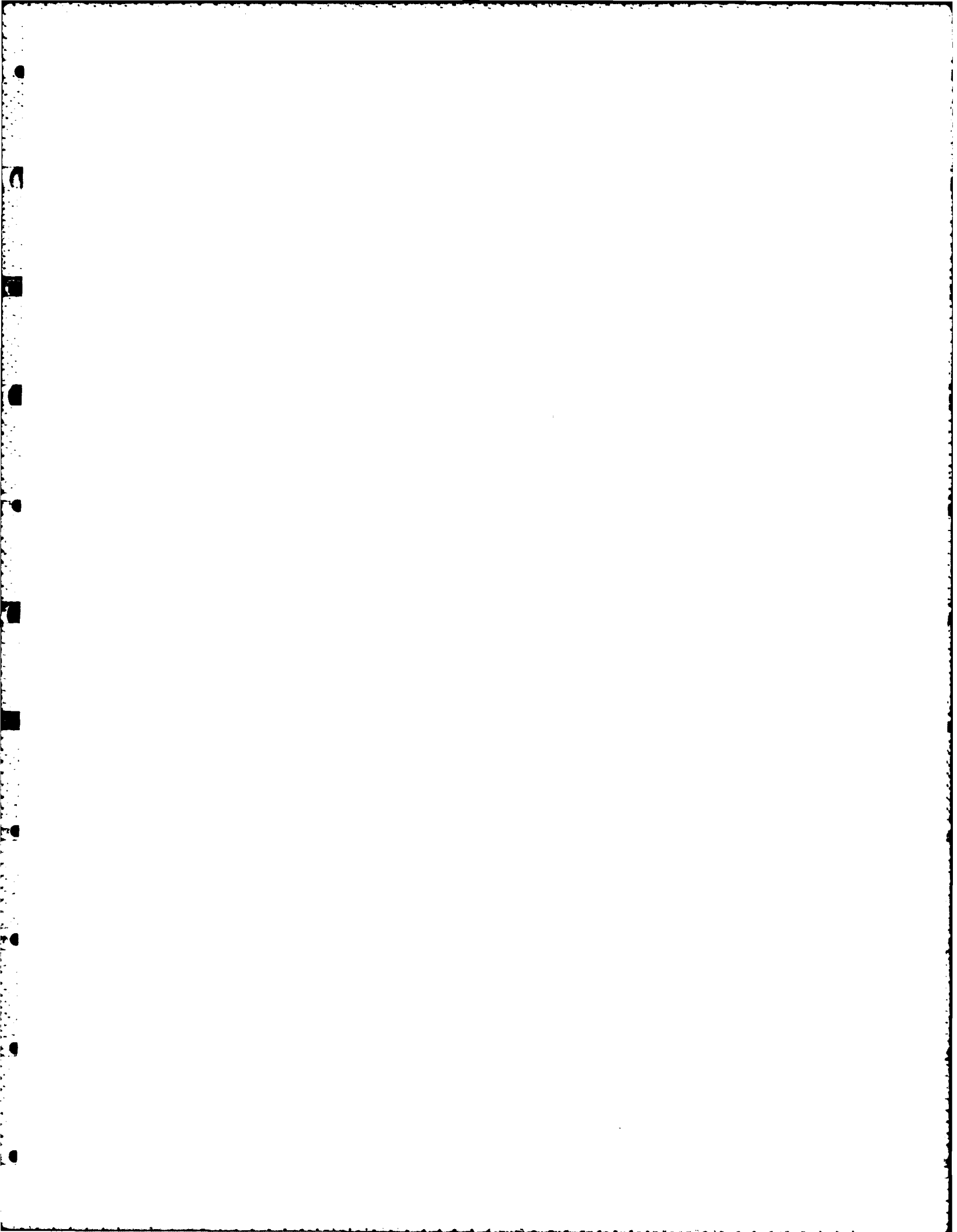

APPENDIX A

CML B SENSORS (FULL LOOP) AIRBORNE  
LIGHTNING MEASUREMENTS

## APPENDIX A

### CML B SENSORS (FULL LOOP)

#### AIRBORNE LIGHTNING MEASUREMENTS

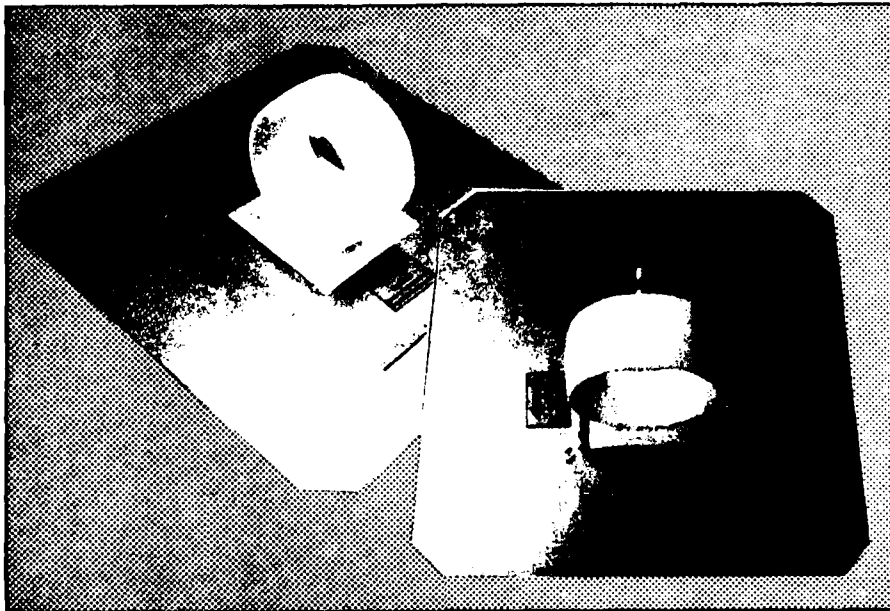

The CML (Cylindrical Moebius Loop) B-dot sensors (Model 7) are used to measure the currents on an aircraft surface caused by a direct or nearby lightning stroke. These probes are passive devices requiring no external power.

These sensors are cylindrical loops with one gap and the pickoff cables wired in a Moebius configuration. The voltage signal developed across the gap by the changing magnetic field associated with the skin currents is sensed in the differential mode by the pickup cables. The Moebius configuration and the differential output provide for common mode rejection of unwanted signals generated in the sensor by electric field components. The output cables of these CML sensors can exit in a variety of ways as shown on the reverse, and the ground plate is sufficiently flexible to conform to a surface with large ( $>1m$ ) curvature radius.

PERTINENT EQUATION

$$V_o = \vec{A}_{eq} \cdot \frac{d\vec{B}}{dt} = \text{sensor output (in volts)}$$

where

$\vec{A}_{eq}$  = sensor equivalent area (in  $m^2$ )

$\vec{B}$  = magnetic flux density vector (in teslas)

SPECIFICATIONS

Parameter	CML-7 or CML-S7
$A_{eq}$ ( $m^2$ )	$2 \times 10^{-2}$
Frequency Response (3 dB point)	38 MHz
Risetime (10-90%)	9 ns
Maximum Output	4 kV (with TCC)
Maximum Field Change	$2 \times 10^5$ tesla sec
Output Connector	TCC*
Mass	1.0 kg
Dimensions (cm)	
L	35.6
D	11.9
H	12.4
A	6.4

\*100-ohm twinaxial connector (Data Sheet 1340); Two 50-ohm SMA connectors optional.

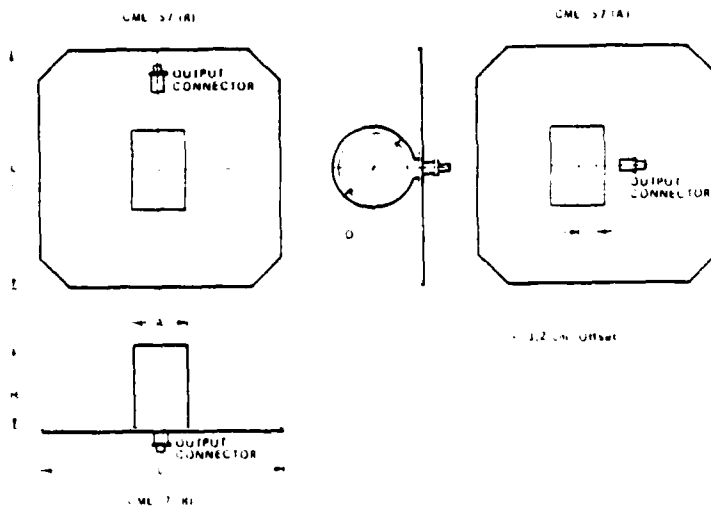

(Data and Specifications Subject to Change without Notice)

APPENDIX B  
FPD  $\dot{D}$  SENSOR

APPENDIX B  
 FPD D SENSOR

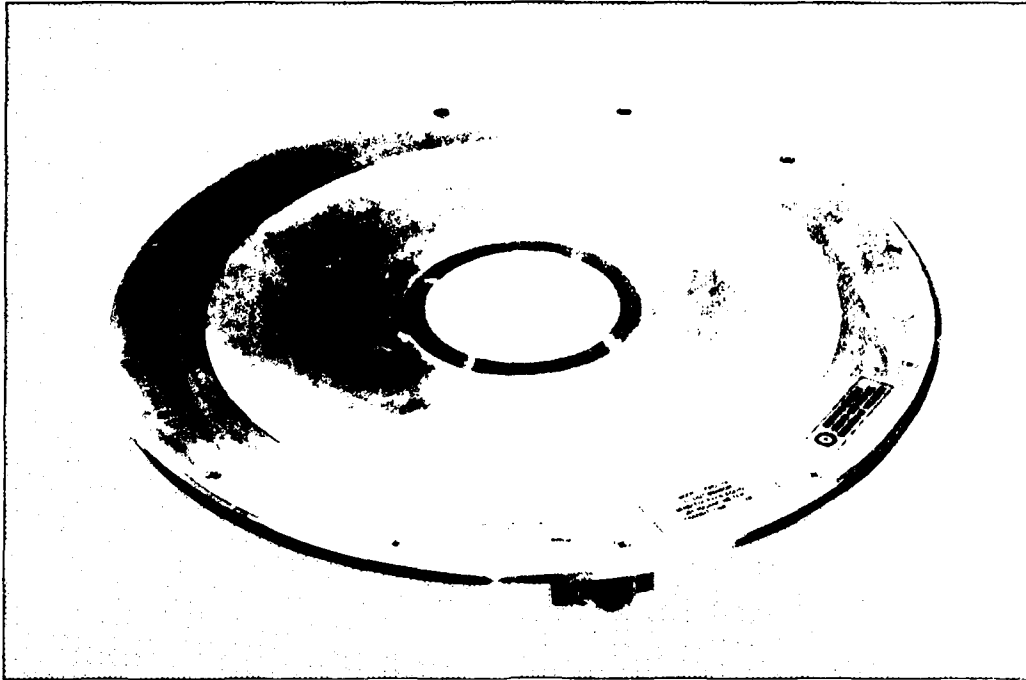

The FPD (Flush Plate Dipole) sensor is mounted in a conducting surface (ground plane, aircraft wing, etc.) and used to measure the normal component of the displacement current ( $d\vec{D}/dt$ ). It can also be used to measure the time rate-of-change of surface charge density  $dq_s/dt$ . (Data Sheet 1117 describes special  $q_s$  sensors.) The FPD sensor is extremely useful in EMP or lightning fields of high electric stress or where minimum perturbation is required. A special version adapts to the wing tip of a C-130 aircraft used for in-flight lightning measurements. The sensor is a passive device and requires no power.

PERTINENT EQUATION

$$I_o = \vec{A}_{eq} \cdot \frac{d\vec{D}}{dt}$$

or

$$V_o = R A_{eq} \frac{dD}{dt} \cos \theta$$

where

$I_o$  = sensor output (in amps)

$V_o$  = sensor output (in volts)

$R$  = sensor characteristic load impedance (50 ohms)

$A_{eq}$  = sensor equivalent area (in  $m^2$ )

$D$  = magnitude of electric displacement vector ( $\vec{D} = \epsilon_0 \vec{E}$ , in  $Coul/m^2$ )

$\theta$  = angle between  $E$  and vector normal to sensor ground plate

SPECIFICATIONS:

FPD-1

$A_{eq}$ ( $m^2$ )	$1 \times 10^{-2}$
Frequency Response (3 dB point)	> 350 MHz
Risetime ( $T_r$ 10-90)	< 1 ns
Maximum Output	$\pm 4$ kV
Output Connector	GR874L (50 ohms)
Mass	4 kg
Dimensions (cm)	
W	43.2
t	1.0
D	5.4

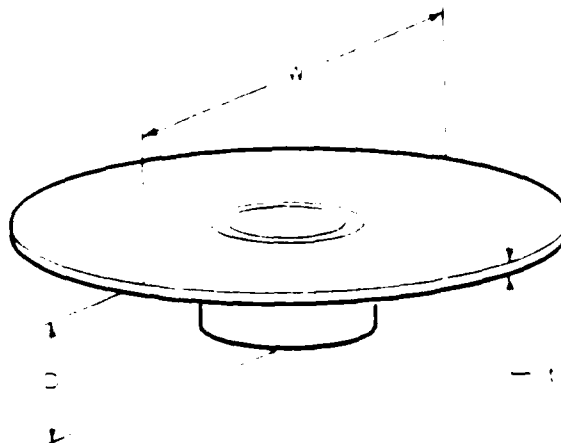

(Data and Specifications Subject to Change without Notice)

AFWAL-TR-83-3031

APPENDIX C  
SLOT SENSOR DATA SHEET

## APPENDIX C

## SLOT SENSOR DATA SHEET

## Slot Sensor Data

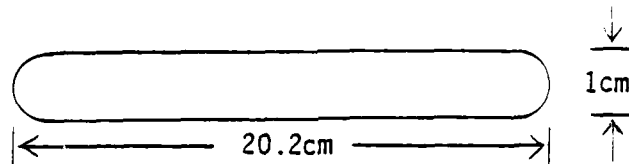

## Equivalent Circuit (Reference 5)

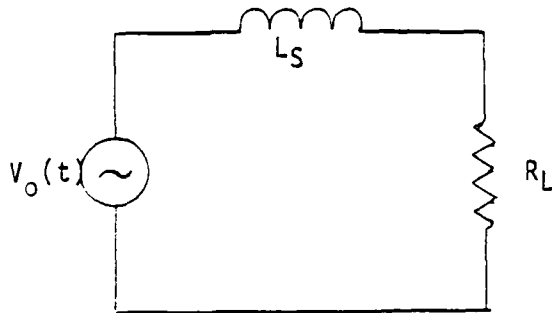

$L_s$  = Slot Inductance

$R_L$  = Load Resistance

$$\dot{V}_o(t) = \dot{B} A_{eq}$$

$$A_{eq} = \frac{\pi \ell^2}{2\{\ln(8\ell/w) - \ln(2)\}}$$

$\ell$  =  $\frac{1}{2}$  slot length,  $w$  = slot width

Since  $B = \mu_o H$ , and, for a cylinder,  $H = \frac{I}{C} = \frac{I}{2\pi r}$  where  $r$  is the cylinder radius ( $\approx 0.5m$ ) and  $\mu_o$  = permeability =  $4\pi \times 10^{-7}$  H,

$$\begin{aligned} V_o(t) &= \frac{\dot{I} \mu_o \ell^2}{4r\{\ln(8\ell/w) - \ln(2)\}} \\ &\approx \frac{\dot{I}(4\pi \times 10^{-7})(0.101)^2}{4(0.5)\{\ln(8 \times 0.101/0.01) - \ln(2)\}} \approx 1.73 \times 10^{-3} \dot{I} \end{aligned}$$

$$I \approx 5.77 \times 10^8 \int_0^t V_o(t) dt$$

Sensor was on 0.06 aluminum panel and connected to 50 ohm transmitter input impedance with about 18 inch RG 174 coax cable.

## Slot Frequency Response

The slot response can be approximated by

$$f_{Hi} = \frac{1}{2\pi} \frac{R_L}{L} \quad \text{where } f_{Hi} \text{ is the upper frequency}$$

L is given by (from Reference 6):

$$L = \frac{\pi \mu l}{2(\ln(8 l/w) - \ln(2))} \approx 5.39 \times 10^{-9} \text{ H}$$

$$f_{Hi} = \frac{1}{2\pi} \frac{50}{5.39 \times 10^{-9}} \approx 148 \text{ MHz}$$

The sensor time constant is given by:

$$\text{T.C.} \approx \frac{L}{R_L} \approx 1.08 \times 10^{-9} \text{ sec.}$$

APPENDIX D

APPLICATION NOTES FOR CURRENT TRANSFORMERS  
MANUFACTURED BY PEARSON ELECTRONICS, INC.

## APPENDIX D

## SPECIFICATIONS OF THE 301x PEARSON CURRENT TRANSFORMER

The Pearson 301x current transformer provides a means of measuring current with the measuring equipment isolated from the current-carrying circuit. The conductor carrying the current to be measured is run through the center of the transformer (Figure 11). Current passing down the conductor induces a current in the transformer. The output of the current transformer is connected via a coaxial cable to a high impedance measuring device, such as an oscilloscope. The voltage waveshape displayed on the oscilloscope will be a faithful reproduction of the actual current waveshape. The voltage amplitude will be related linearly to the current amplitude by the transfer impedance (sensitivity) in volts/amp. The bandwidth is roughly given by the risetime, the droop and the low frequency 3-db down point. The droop is essentially the change in the voltage displayed of a constant current with time and hence is related to the 3 db down point. The specifications of the Pearson 301x current transformer are as follows:

Sensitivity (accuracy +1%,-0%)	0.01 Volts/Amp
Inner diameter	3.5 inches
Maximum Current	
Peak	50,000 amps
RMS	400 amps
Risetime	20 nanoseconds
Droop (% of amplitude/microsecond)	0.0005
Low Frequency 3-db point	1 Hz

APPENDIX E

NMIMT TECHNICAL REPORT ON THE TRIGGERING OF LIGHTNING  
WITH WIRE-TRAILING ROCKETS DURING TRIP '81

The following is the technical report of Prof C. B. Moore of the New Mexico Institute of Mining and Technology on his effort in the Rocket Triggered Lightning Investigation. The photographs with the report were unsuitable for reproduction and were omitted. However, similar photographs appear in the body of this report. The correspondence between the photographs is as follows:

NMIMT Report Figure Number	AFWAL Report Figure Number
1	3 & 7
2	3
3	3
4	2



# NEW MEXICO INSTITUTE OF MINING AND TECHNOLOGY

SOCORRO 87801

DEPARTMENT OF PHYSICS

December 14, 1981

Major Charles Shubert  
Wright-Patterson Air Force Base  
Dayton, Ohio 45433

Subject: Technical Report on the Triggering of Lightning with  
Wire-Trailing Rockets During Trip '81

Gentlemen:

With support under contract #F33615-81-K-3415, the Langmuir Laboratory group of the New Mexico Institute of Mining and Technology carried out an experiment on the triggering of lightning and supported studies on the effect of lightning on aircraft instrumentation.

For this experiment, we made arrangements with the French Scientists at (ONERA, Office National Etud Research Aeronautique, M. Jean Louis Boulay and M. Pierre La Roche) and with the (CEA, Commisariat Energie Atomique, Dr. Pierre Hubert) for their participation. These scientists have developed the technique of triggering lightning by the injection of rockets trailing grounded wires into the strong field region beneath thunderclouds. Although the idea is American and was first demonstrated by Morris Newman off the coast of Florida in 1962, the French have adapted a long burning, slowly accelerating rocket that has been much more successful than many of the American efforts in triggering lightning. The French scientists made arrangements to bring 100 of their rockets and about 6,000 kilograms of instrumentation from Paris to Socorro for the 1981 experiment.

The Langmuir Laboratory group arranged a rocket launch area on the crest of Magdalena Mountains at an altitude of 3,223 meters. The coordinates of the center of the rocket launching facility was 764 meters west of Langmuir Laboratory radar, 1351 meters north of the radar, and 30.2 meters below the radar dish. (The radar is the

center of the Langmuir Laboratory coordinate system @ 33 degrees, 58 minutes, 31 seconds north latitude, 107 degrees 10 minutes 50.6 degrees west longitude.)

For the rocket launching facility, we obtained four wooden poles 20 meters long and about 45 cm diameter at the base. The poles were sealed by spraying them with white paint so as to minimize water absorption and retention and thereby maintain their qualities as an insulator. Three holes, arranged in an equilateral triangle 6 meters on the side, were dug, each 2 meters deep. Three of the poles were erected vertically in these holes and cross-braced at the top by 2" x 12" timbers, 6 meters long as shown in Figure 1. (The fourth pole was held in reserve as a spare in case of lightning damage to one of the other poles in use.) Each of the vertical poles was capped with a high voltage insulator rated for 100 kV service. On top of the insulators a triangular platform was constructed and covered with a marine plywood sheet as a walking surface.

Our French collaborators, (Andre Eybert Berard and Louis Barret) erected three rocket launchers on the corners of the triangular platform above the poles with supports for the bobbins holding the wires mounted near the center of the triangle. A 40 centimeter hole was placed near the center of the platform and feed-through high voltage insulator was mounted in the hole. The arrangement was so that such that, after a rocket was launched, it pulled a wire from the supply spool which was connected through the feed-through insulator to an electrode mounted about 2 meters or so below the top of the work platform.

Pulleys were installed around the tops of each vertical pole and a strong poly-propylene line was passed through these pulleys. A simulated aircraft fuselage shape approximately 8 meters long and 1/2 meter in diameter and containing US Air Force measuring instruments was hung vertically from these lines beneath the discharge electrode on the top surface.

In the center of tripod arrangement, the French investigators placed an insulated instrumentation shelter approximately 2 meters high. On the top of this instrumentation shelter, a second electrode was placed to receive the discharges that left the lower end of the simulated aircraft fuselage. These structures are shown in Figures 1-4.

In addition to the rocket launchers placed on top of the tripod the French investigators provided two additional rocket launching installations. One set was located on the ground just to the south of the tripod and consisted of the standard French launchers connected to wire bobbins on grounded supports located between the launcher and the tripod. The rockets from these launchers were the same variety used on the tripod, and, when fired, carried either instrumentation or a grounded wire upward for triggering experiments.

The third launcher was located about 40 meters to the southeast of the tripod; it used a different triggering arrangement. The rockets launched from this last tripod were named "Topsy" by the French. These rockets carried a bobbin on which was wound Kevlar strands together with a fine copper wire about 0.1 mm in diameter. The copper wire terminated at the bottom end about 100 meters above the ground so that there was no direct contact with the earth as the rocket ascended. Instead, a lengthening conductor separated from the earth by about 100 meters was injected into the high field region beneath these thunderclouds. This was part of a French experiment to investigate the breakdown mechanism of lightning and it produced some interesting results.

The installation was completed on July 14, 1981 and the first rockets were fired on that date. Subsequently, in the course of the summer, sixty-seven wire trailing rockets were fired and major lightning discharges were triggered by 42 of these firings.

The French rockets has a mass of about 2.9 kilograms and the engine has a burn duration of about 4 seconds. (The maximum speed of the rocket at burn out is about 180 m/sec.) The rockets towing wires typically rose to an altitude of about 1000 meters above the 3225 meter launch altitude. When the rocket was towing a grounded wire, lightning commonly occurred about 3 seconds after a launch when the rocket was an altitude of about 200 meters and moving faster than 100 m/sec. The lowest trigger occurred when the rocket was 50 m above the launch site.

A list of the firing times, dates and the rocket types is given in Table 1. The rockets were fired under many different conditions, some unfavorable for the triggering of lightning. In addition, some of the rockets that were used had been instrumented for measuring corona currents and were, therefore, not designed for triggering. The potential success ratio of triggers to rocket launches is appreciably higher than indicated by the summary figures because the French carried out experiments to determine the minimum conditions for triggering. Lightning was triggered from the thunderclouds routinely whenever the electric field strength at the earth exceeded about 7 kV per meter when the dominant charge in the base of the thunderclouds overhead was negative. On the other hand, when the dominant charge in the thundercloud overhead was positive, lightning was rarely, if ever, triggered regardless of the strength of the field at the earth's surface. It appears from this that upward-going positive streamers propagate significantly easier into a negatively charged region than do negatively charged streamers into a positively charged region.

The Topsy rockets with their ungrounded wire were successful in triggering lightning but, only after the rockets had risen much higher in the cloud and at an appreciable longer time after launch. Some of these discharges induced by the Topsy rockets were green in color suggesting the excitation of the copper strand. Usually, the Topsy rockets triggered lightning that was

more nearly similar to natural lightning than were the strokes triggered by the grounded wires.

Rocket operations terminated on August 20, 1981 as the frequent storms began to decrease. The French equipment was packed up for return to Paris. The work platform was lifted off of the top of tripod by a crane and set on the earth for the Winter. The three poles of the tripod were guyed and braced to assist them in withstanding the winter winds so that they could be used in the 1982 summer.

Instrumentation: We surrounded the rocket launch site with electric and acoustic measuring instruments in an effort to determine some of the behavior characteristics of the triggered lightning. On top of South Baldy Peak, about 350 meters to the North North East, a set of electromagnetic recording instruments recorded magnetic and electric field parameters with 10 nanosecond resolution. At the same station, an electric field change meter, a thunder sensing microphone and a video camera photographing the whole sky over the summit of South Baldy Peak with a 16 millisecond resolution were operated during these periods.

Two acoustic arrays of microphones for measuring the time difference of arrival of individual thunder peals over the network were operated about 1 kilometer to the south of the rocket launcher. The data shown in Figure 5 were obtained from the Saddle Array of microphones used here.

Video cameras were also operated at Langmuir Laboratory Annex where a wide angle lens was used on a charge coupled vidicon to obtain the lightning view from the south. An array of five electric field meters around the mountain top was recorded at Langmuir Laboratory.

Selected data from these sensors are attached in the Appendix. These data are still being reduced and analyzed and will be presented when the analysis is completed.

Very truly yours,

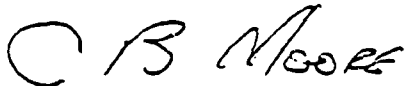

Charles B. Moore  
Chairman, Langmuir Laboratory

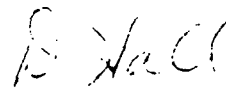

D. Hall  
Research Investigator

CBM/do

TABLE 1  
ROCKET LAUNCHES  
TRIP 81

Launch No.	Year date	Date	Time (MST)	Type	Triggered	Lightning
	French Rockets					
1	81195	July 14	14:35	Ground	No	
2		July 24			No	
3	81205	July 24	14:01:39	Tipsy	No	
4		July 24	14:04:22	Ground	No	
5	81211	July 30	13:03:08	Tripod	Yes	
6		July 30	13:05:10	Tripod	Yes	
7		July 30	13:09:48	Tripod	No	
8		July 30	13:28:00	Ground	Yes	
9		July 30	14:35:04	Ground	No	
10	81213	Aug. 1	14:48:40	Ground	No	
11		Aug. 1	15:48:23	Ground	Yes	
12		Aug. 1	16:01:03	Tripod	No	
13		Aug. 1	16:23:01	Tripod	No	
14		Aug. 1	17:02:28	Ground	Yes	
15		Aug. 1	17:11:50	Tripod	Yes	
16		Aug. 1	17:16:24	Ground	Yes	
17		Aug. 1	17:22:44	Ground	No	
18	81214	Aug. 2	19:02:43	Ground	Yes	
19		Aug. 2	19:13:31	Tripod	No	
20		Aug. 2	19:23:31	Ground	Yes	
21	81216	Aug. 4	16:08:38	Ground	No	
22		Aug. 4	21:02:05	Ground	No	
23		Aug. 4	21:31:05	Ground	Yes	
24		Aug. 4	21:35:35	Tripod	Yes	
25		Aug. 4	21:39:28	Ground	Yes	
26	81221	Aug. 9	13:06:10	Tipsy	Yes	
27		Aug. 9	13:15:46	Ground	Yes	
28	81222	Aug. 10	14:46:25	Tripod	Yes	
29		Aug. 10	14:52:02	Tripod	Yes	
30	81223	Aug. 11	15:29:03	Ground	No	
31		Aug. 11	15:43:24	Ground	Yes	
32	81224	Aug. 12	14:04:26	Ground	Yes	
33	81225	Aug. 13	15:35:40	Ground	No	
34		Aug. 13	15:38:50	Ground	Yes	
35		Aug. 13	15:39:35	Ground	Yes	
36		Aug. 13	15:40:38	Tipsy	Yes	
37		Aug. 13	15:41:30	Tripod	Yes	
38		Aug. 13	15:42:50	Ground	Yes	
39		Aug. 13	15:47:00	Tipsy	No	
40	81226	Aug. 14	13:31:15	Tripod	Yes	
41		Aug. 14	13:34:16	Tipsy	Yes	
42		Aug. 14	13:37:20	Tripod	Yes	
43		Aug. 14	13:43:13	Ground	Yes	
44		Aug. 14	13:47:52	Tipsy	Yes	
45		Aug. 14	13:49:11	Ground	No	
46		Aug. 14	13:53:39	Ground	Yes	

TABLE 1 (Concluded)

47		Aug. 14	14:20:24	Ground	Yes
48		Aug. 14	14:22:56	Tipsy	No
49		Aug. 14	14:25:34	Ground	Yes
50		Aug. 14	15:04:33	Ground	Yes
51	81228	Aug. 16	12:43:41	Tripod	No
52		Aug. 16	12:51:32	Ground	No
53		Aug. 16	12:54:34	Ground	Yes
54		Aug. 16	12:57:41	Tripod	No
55		Aug. 16	13:00:23	Tripod	No
56	81229	Aug. 17	15:55:38	Ground	Yes
57		Aug. 17	15:55:42	Tripod	
(Rocket triggered by lightning from a previous discharge)					
58		Aug. 17	16:01:36	Tripod	Yes
59		Aug. 17	16:03:00	Ground	No
60	81230	Aug. 18	15:42:56	Ground	Yes
61		Aug. 18	15:44:19	Tipsy	Yes
62		Aug. 18	15:47:20	Tripod	Yes
63		Aug. 18	15:48:46	Tipsy	Yes
64		Aug. 18	15:59:18	Ground	No
65		Aug. 18	16:01:30	Tripod	Yes
66		Aug. 18	16:03:17	Tipsy	No
67		Aug. 18	16:06:35	Tripod	Yes
68		Aug. 18	16:09:17	Ground	No

## Kiva (Colgate's small rockets)

1		Aug. 11	15:50:36		No
2		Aug. 14	13:33:38		No
3		Aug. 14	15:08:32		No
4		Aug. 18	15:49:32		Yes

TABLE 2

## LIST OF ROCKETS FIRED IN SUMMER OF 1981

	Tripod	Tipsy	Ground	Total French	Kiva
# Rockets Fired	20	10	37	67	5
#Successfully Triggering of Lightning	14	7	21	42	1

First rocket fired --> July 14

First successful trigger --> July 30, 1981

Operations through --> August 20, 1981

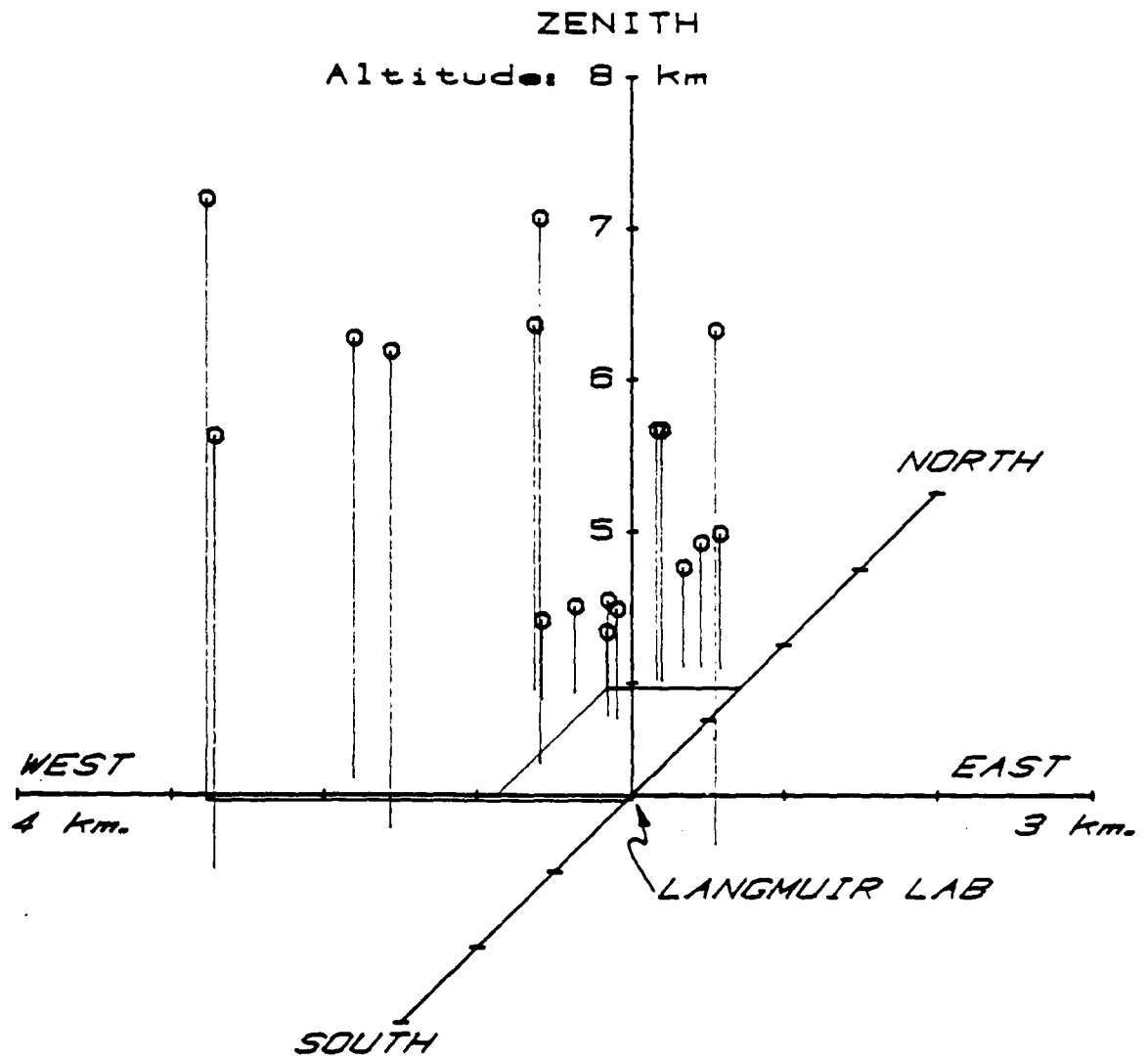

81211 47110.518 ●●●  
1305:10.518 M. S. T.

Figure E-5a. Acoustic Reconstructions of the Thunder Source Locations for the Second Triggering Lightning on Day 81211 (July 30, 1981).

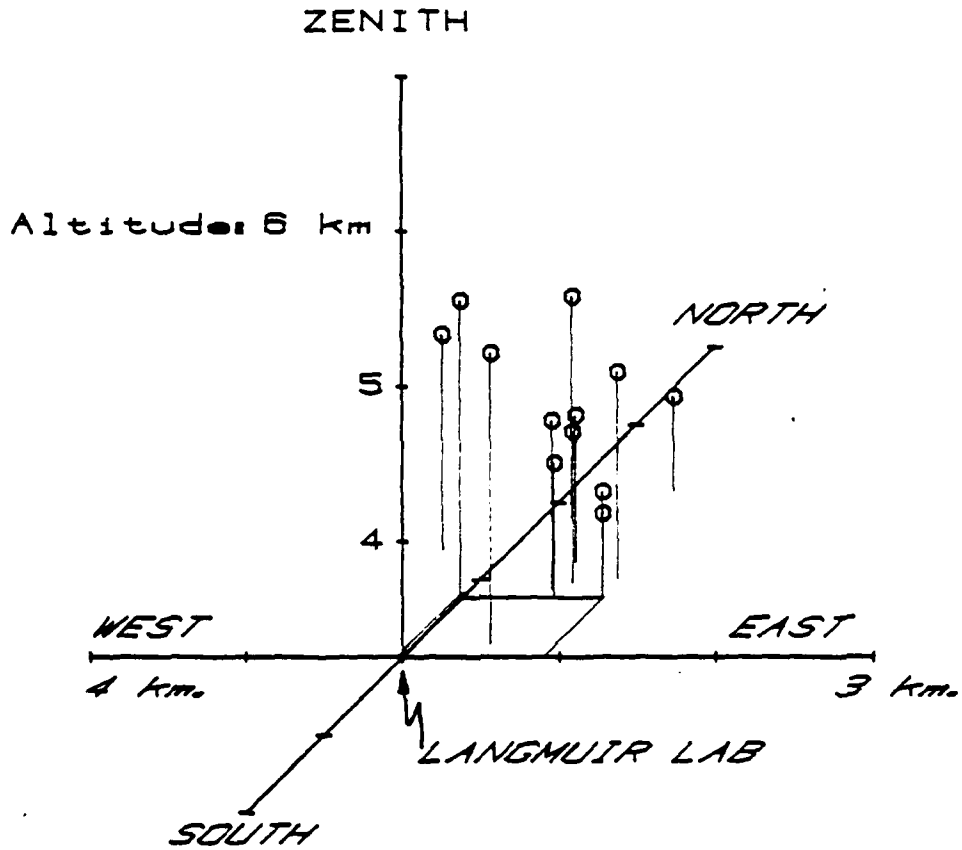

81211 47811 sec  
1316.51 M. S. T.

Figure E-5b. Acoustic Reconstructions of the Thunder Source Locations for the Second Intra-Cloud Lightning that Lowered Positive Charge from the Region of the "Lower-Positive-Charge-Center" Created by the Rocket-Triggered Lightning at 13:03:08 MST.

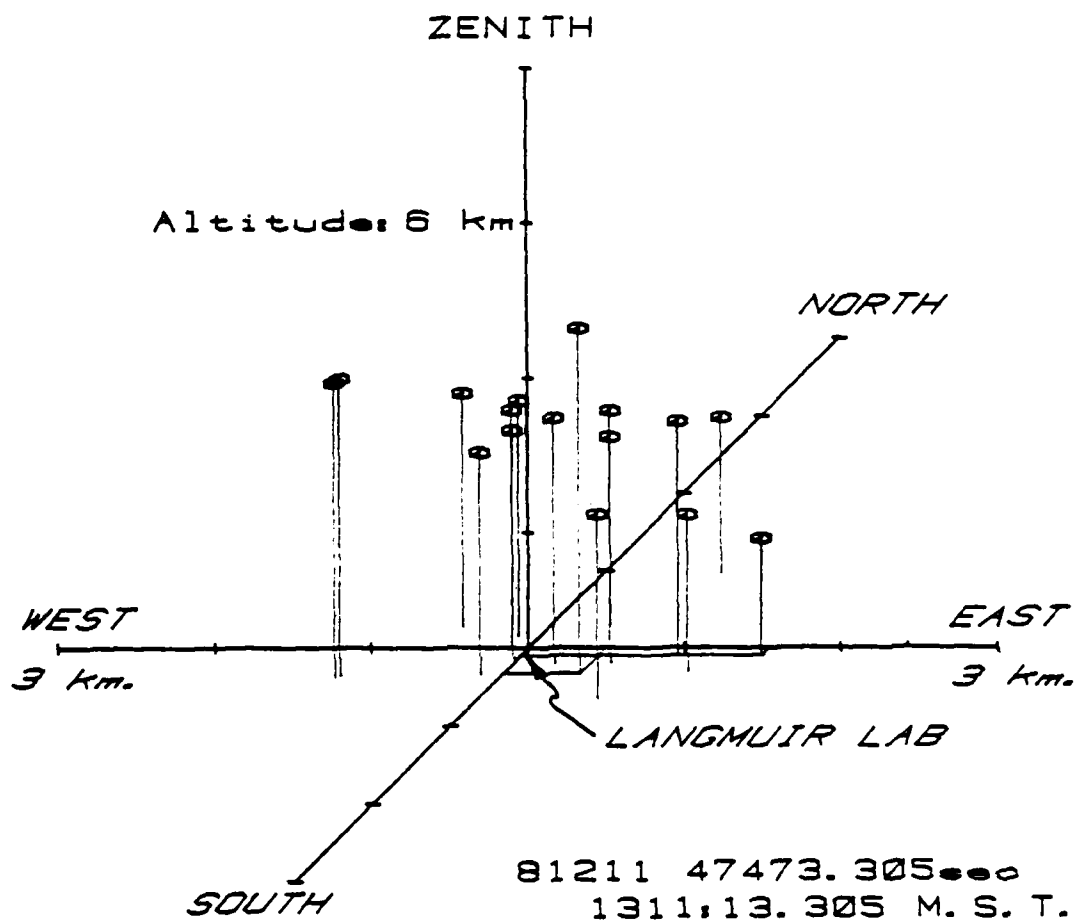
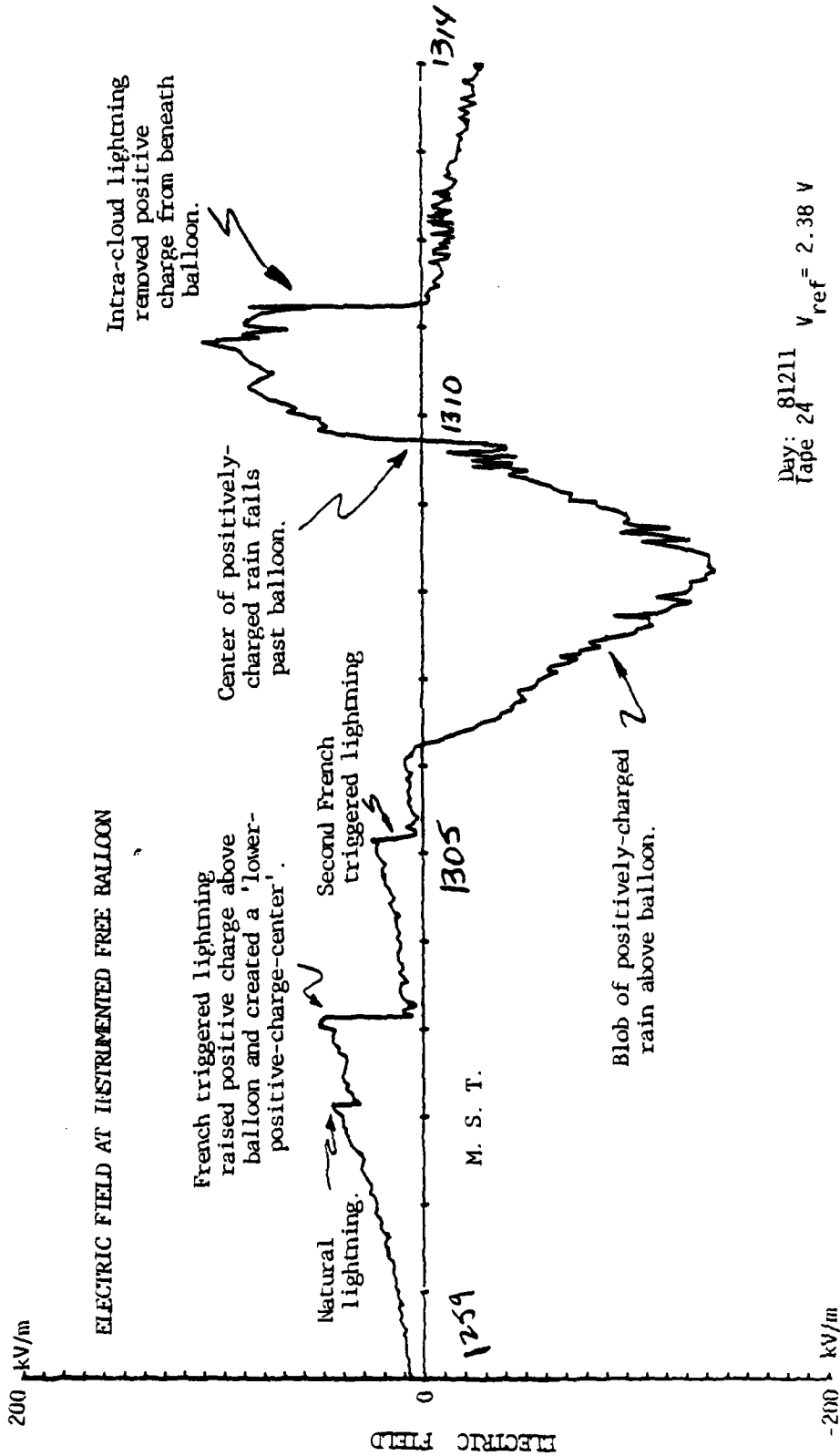
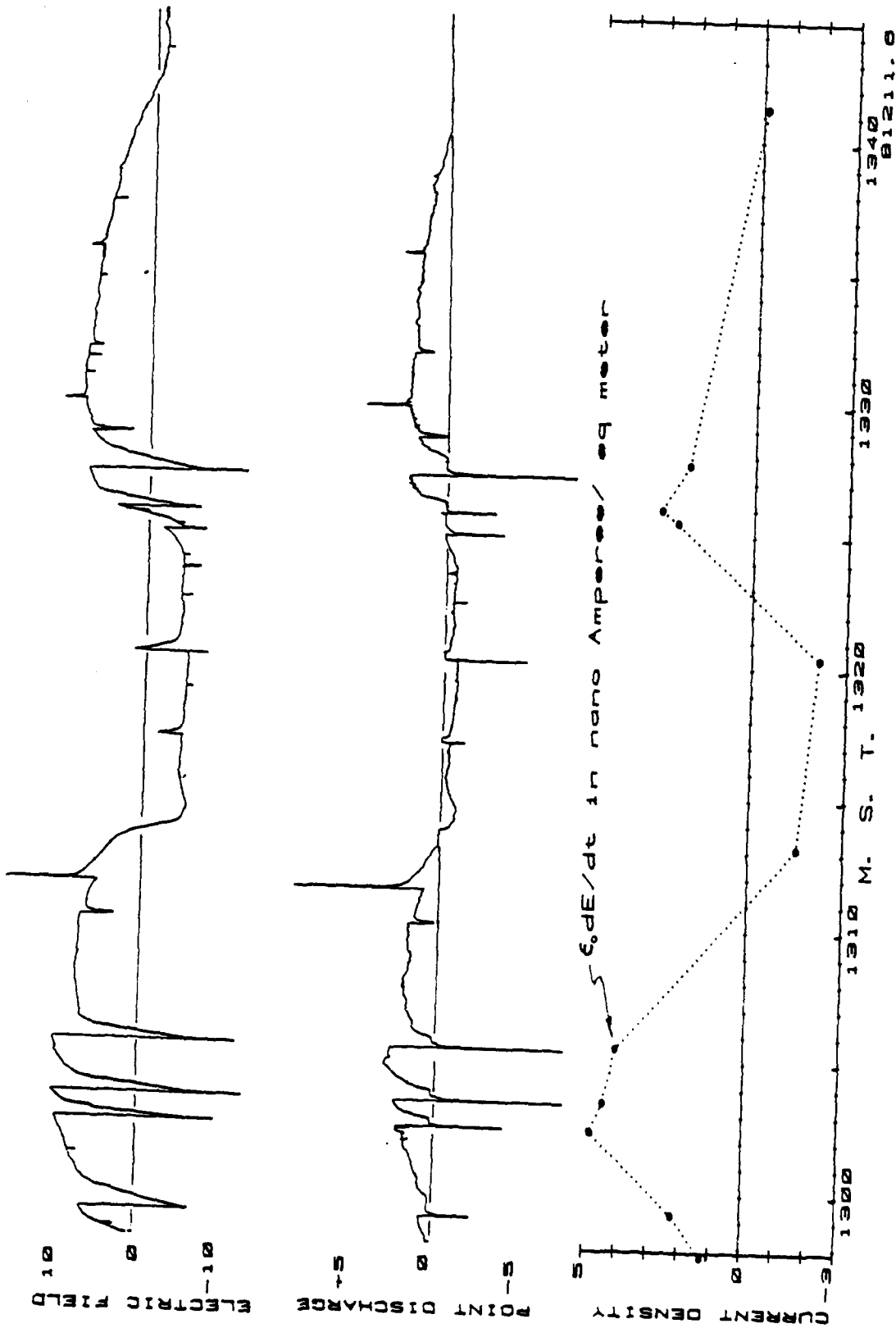

Figure E-5c. Acoustic Reconstructions of the Thunder Source Locations for the Intra-Cloud Lightning that Lowered Positive Charge from Below the Free Balloon. This flash was caused by the 'lower-positive-charge-center' created earlier by the rocket-triggered lightning.





Electric Field, Point Discharge Current and Displacement Current Density at the Kiva on South Baldy Peak During the Thunderstorm on Day 81211 (July 30). The French triggered lightning at 13:03:08 and 13:05:10 MST and caused a lower-charge-center in the cloud. Positively-charged rain fell out and caused the bay in the electric field record between 13:13 and 13:26 MST. This excursion was seen earlier by W.P. Winn's instrumented free balloon launched at about 12:57 MST.

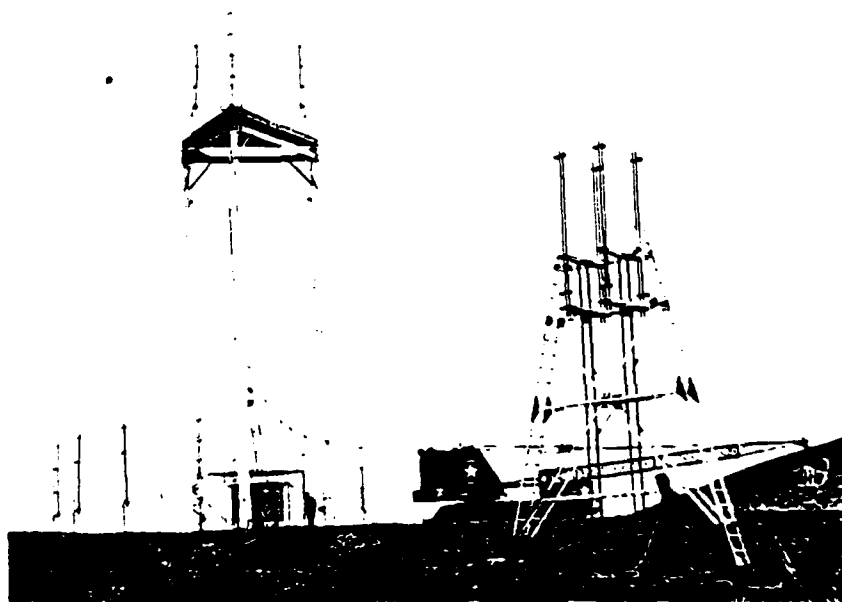

Figure E-1. A View of the French Rocket Launchers and the Instrumentation Tripod Used to Study the Effects of Triggered Lightning at Langmuir Lab During 1981. The tripod is 18 m high and supports 3 launchers and the USAF simulated aircraft fuselage.

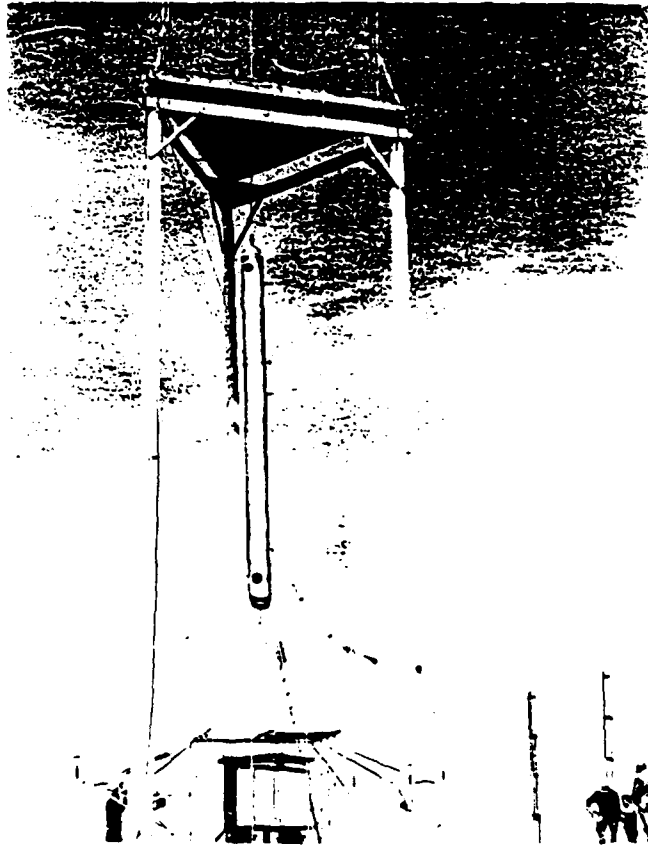

Figure E-2. A View of the Tripod and the USAF Simulated Aircraft Fuselage Instrumented to Measure Lightning Currents.

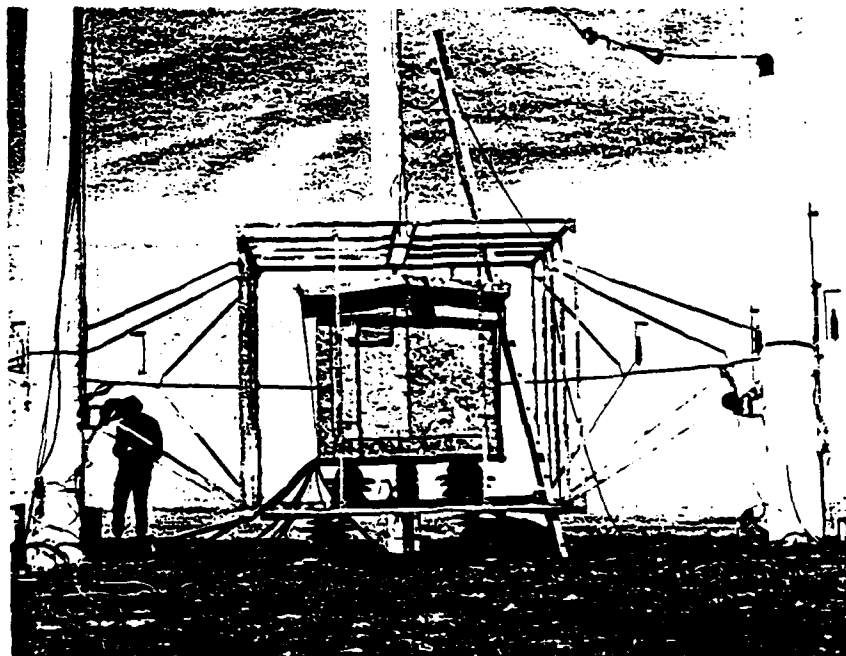

Figure E-3. A Photograph of the French Instrumentation Shelter Used to Measure Lightning Currents.

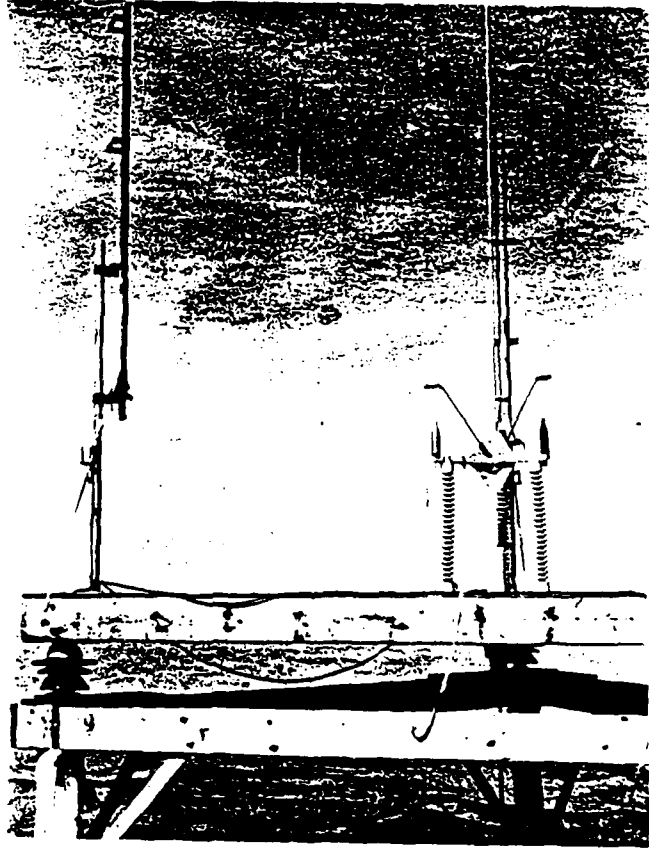

Figure E-4. A View of the Top of the Instrumentation Tripod Showing the Insulators Supporting the Platform, the Rocket Launchers, and the Wire Bobbins that Feed the Wire Trailed by a Rocket.

REFERENCES

1. Charles W. Schubert, Jr. and J.R. Lippert, "Investigation into Triggering Lightning with a Pulsed Laser", in Digest of Technical Papers, 2nd IEEE International Pulse and Power Conference (Lubbock, Texas, 12-14 June 1979), A.H. Guenther and M. Kristiansen, Editors, IEEE Catalog Number 79CH1505-7.
2. Laser-Triggered Lightning Experiment, Silent Audiovisual Film SPR 23-78, Defense Audiovisual Agency/DAUA-N-LGD, Norton Air Force Base, California 92409.
3. P. LaRoche, "Eight Years of Triggered Lightning; Research at St Privat d' Allier", in 1982 Conference on Lightning and Static Electricity Proceedings (Culham Laboratory, England, 23-25 March 1982), Abingdon, Oxfordshire OX143DB, England.
4. The Irving Langmuir Laboratory for Atmospheric Research, Information Pamphlet, New Mexico Institute of Mining and Technology, Socorro, New Mexico 87801, 1977.
5. A.L. Whitson, Engineering Techniques for Electromagnetic Pulse Hardners Testing, DNA Report No. DNA3332F, Stanford Research Institute, 16 Sept. 1974 (AD 786722).
6. E.F. Vance, Field Mapping and Data Analysis for a Long-Wire Antenna, Stanford Research Institute, Technical Report 1 prepared under sub-contract BDM-S1-67-C-66 for Braddock, Dunn and McDonald, Inc., 1967.

