

AD-A131 686

A LATENT TRAIT MODEL FOR DIFFERENTIAL STRATEGIES IN  
COGNITIVE PROCESSES(U) TENNESSEE UNIV KNOXVILLE DEPT OF  
PSYCHOLOGY F SAMEJIMA JUN 83 RR-83-1 N00014-81-C-0569

1/1

UNCLASSIFIED

F/G 5/10

NL

END

FILED

10

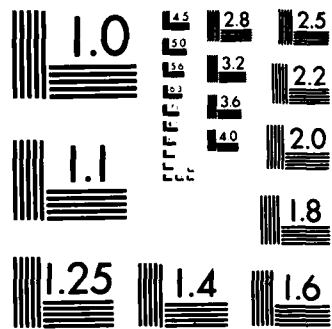

MICROCOPY RESOLUTION TEST CHART  
NATIONAL BUREAU OF STANDARDS-1963-A

2

# A LATENT TRAIT MODEL FOR DIFFERENTIAL STRATEGIES IN COGNITIVE PROCESSES

FUMIKO SAMEJIMA

UNIVERSITY OF TENNESSEE  
KNOXVILLE, TENN. 37996-0900

JUNE, 1983

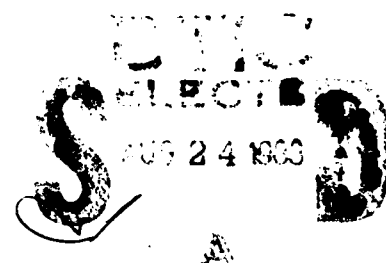

Prepared under the contract number N00014-81-C-0569,  
NR 150-467 with the  
Personnel and Training Research Programs  
Psychological Sciences Division  
Office of Naval Research

Approved for public release; distribution unlimited.  
Reproduction in whole or in part is permitted for  
any purpose of the United States Government.

R01-1068-71-002-84

ADA 131686

DTIC FILE COPY

83 08 23 09 6

Unclassified

SECURITY CLASSIFICATION OF THIS PAGE (When Data Entered)

REPORT DOCUMENTATION PAGE		READ INSTRUCTIONS BEFORE COMPLETING FORM
1. REPORT NUMBER ONR/Research Report 83-1	2. GOVT ACCESSION NO. A131686	3. RECIPIENT'S CATALOG NUMBER
4. TITLE (and Subtitle) A Latent Trait Model for Differential Strategies in Cognitive Processes	5. TYPE OF REPORT & PERIOD COVERED Technical Report	
	6. PERFORMING ORG. REPORT NUMBER	
7. AUTHOR(s) Dr. Fumiko Samejima	8. CONTRACT OR GRANT NUMBER(s) N00014-81-C-0569	
9. PERFORMING ORGANIZATION NAME AND ADDRESS Personnel and Training Research Programs Office of Naval Research Arlington, VA 22217	10. PROGRAM ELEMENT, PROJECT, TASK AREA & WORK UNIT NUMBERS PE: 61153N; PROJ:RR-042-04 TA: RR 042-04-01 WU: NR 150-467	
11. CONTROLLING OFFICE NAME AND ADDRESS	12. REPORT DATE	
	13. NUMBER OF PAGES	
14. MONITORING AGENCY NAME & ADDRESS (if different from Controlling Office)	15. SECURITY CLASS. (of this report) Unclassified	
	15a. DECLASSIFICATION/DOWNGRADING SCHEDULE	
16. DISTRIBUTION STATEMENT (of this Report) Approved for public release; distribution unlimited. Reproduction in whole or in part is permitted for any purpose of the United States government.		
17. DISTRIBUTION STATEMENT (of the abstract entered in Block 20, if different from Report)		
18. SUPPLEMENTARY NOTES		
19. KEY WORDS (Continue on reverse side if necessary and identify by block number) Operating Characteristic Estimation Tailored Testing Latent Trait Theory		
20. ABSTRACT (Continue on reverse side if necessary and identify by block number)  (Please see reverse side)		

DD FORM 1 JAN 73 1473

EDITION OF 1 NOV 65 IS OBSOLETE  
S/N 0102-LF-014-6601

Unclassified  
SECURITY CLASSIFICATION OF THIS PAGE (When Data Entered)

Some cognitive psychologists, who have tried to approach psychometric theories, say that they do not provide them with theories and methods with which they can deal with differential strategies. They are not exactly right. As early as in the late nineteen-sixties, the heterogeneous case of the graded response level in the context of latent trait theory was proposed (A general model for the operating characteristic of graded item response, Psychometric Laboratory Report No. 55, 1967, University of North Carolina) as a model for cognitive processes. Some useful hints for differential strategies are seen elsewhere (A general model for free-response data, Psychometrika Monograph No. 18, 1972, Section 3.4) under the title, "Multi-correct and multi-incorrect responses."

In the present paper, following the same line, a general latent trait model for differential strategies in cognitive processes is proposed, and the maximum likelihood estimation of the individual's latent trait is discussed.

A LATENT TRAIT MODEL FOR DIFFERENTIAL STRATEGIES  
IN COGNITIVE PROCESSES

ABSTRACT

Some cognitive psychologists, who have tried to approach psychometric theories, say that they do not provide them with theories and methods with which they can deal with differential strategies. They are not exactly right. As early as in the late nineteen-sixties, the heterogeneous case of the graded response level in the context of latent trait theory was proposed (A general model for the operating characteristic of graded item response, Psychometric Laboratory Report No. 55, 1967, University of North Carolina) as a model for cognitive processes. Some useful hints for differential strategies are seen elsewhere (A general model for free-response data, Psychometrika Monograph No. 18, 1972, Section 3.4) under the title, "Multi-correct and multi-incorrect responses."

In the present paper, following the same line, a general latent trait model for differential strategies in cognitive processes is proposed, and the maximum likelihood estimation of the individual's latent trait is discussed.

Accession For	
NTIS GRA&I	<input checked="" type="checkbox"/>
DTIC	<input type="checkbox"/>
Unannounced	<input type="checkbox"/>
Distribution/	
Availability Codes	
Available and/or	
Distribution	
Special	

3  
UNIVERSITY  
4402  
D120

The research was conducted at the principal investigator's laboratory, 405 Austin Peay Hall, Department of Psychology, University of Tennessee, Knoxville, Tennessee. Those who worked for her as assistants include Paul S. Changas, Vicki Newton, Donald Reece Danna, Cornelia Chapman, Hossein H. Kord, Donna Reynolds, Nancy Cossentine, and Philip Livingston.

## TABLE OF CONTENTS

	Page
I Introduction	1
II Cognitive Process as Digraphs	3
III Differential Strategy Tree	9
IV A General Model for Differential Strategies	13
V Homogeneous Case	23
VI Single Strategy Case	27
VII Discussion and Conclusions	37
References	39
Appendix	43

## I Introduction

A general model for free-response data has been proposed by the author (Samejima, 1972) which includes three different response levels, i.e., the nominal response level, the graded response level, and the dichotomous response level. The general graded response model is further classified into the homogeneous and the heterogeneous cases.

Two of the most common uses of the graded response model may be for test items which have more than two item score categories, e.g., A, B, C, D and F, and for questionnaire items with multiple response categories, e.g., "strongly disagree," "disagree," "agree," and "strongly agree." The rationale behind this general model is, however, originally based upon the general sequential cognitive process, which has been described elsewhere (Samejima, 1967).

Let  $\theta$  be the latent trait underlying the cognitive process. When the latent space is unidimensional,  $\theta$  is the set of all real numbers, and, when it is multidimensional,  $\theta$  is a vector of  $k$  sets of real numbers, such that

$$(1.1) \quad \theta = (\theta_1, \theta_2, \dots, \theta_k)' ,$$

with  $k$  indicating the dimensionality. In the present paper, however, we deal solely with the unidimensional latent space.

Let us take problem solving as an example. Suppose that for solving the problem  $g$  we need  $m_g$  sequential subprocesses. Let  $y_g$  denote the attainment category or attainment score. One must

successfully follow all the  $m_g$  sequential subprocesses in order to solve the problem  $g$ , so the attainment category  $y_g$  assumes integers, 0 through  $(m_g+1)$ , with  $y_g = 0$  indicating that the individual subject has successfully followed no subprocesses, and with  $y_g = m_g$  meaning that he has completed all  $m_g$  subprocesses required to solve the problem. The additional attainment score,  $(m_g+1)$ , represents that the subject has successfully followed the additional subprocess which is hypothesized at the end of the entire sequence of subprocesses. Since no one can accomplish this, the conditional probability, given  $\theta$ , with which the subject obtained the attainment score  $y_g$  equals zero, regardless of the fixed value of  $\theta$ . With this setting, we can see that the general graded response model can readily be applied to the single strategy case of problem solving. In this paper, however, our main objective is to approach a general model for the multiple strategy case, or differential strategies, in the context of latent trait theory.

The operating characteristic of a discrete response relates the response to the latent trait  $\theta$ . In the context of problem solving, this operating characteristic is considered with respect to an attainment score, or to a union of attainment scores. It takes an important role in estimating the subject's latent trait from his performance.

As concrete mathematical models, we shall consider those in the homogeneous case, which was expanded and generalized from the one on the graded response level.

## II Cognitive Process as Digraphs

It is a fairly common phenomenon that there exist more than one way of solving a problem. In proving mathematical theorems, for example, we often find one proof plus several alternative proofs for one theorem. To represent those differential strategies graphically, Figure 2-1 presents a simple example of a two strategy case in the form of a graph, each strategy having a small number of subprocesses. In this example, if we take the first strategy, then we must traverse the path,  $v_0 v_1 v_2 v_3 v_4$ , whereas we must follow another path  $u_0 u_1 u_2 u_3 u_4 u_5$  if we take the second strategy, in order to solve the problem. Note that, although we have duplicate symbols,  $v_0 = u_0$ ,  $v_1 = u_1$ ,  $v_3 = u_4$  and  $v_4 = u_5$ . These two paths represent the two successful strategies for solving our hypothetical problem, and are shown as two directed subgraphs of the original graph, or digraphs, in Figure 2-2.

When the subject falters, he may not follow either of the two paths shown in Figure 2-2. In such a case, we need additional arcs in the digraph presented as Figure 2-1, examples of which are shown by thin lines in Figure 2-3. Two examples of the directed subgraphs of Figure 2-3, which represent "faltering," are presented in Figure 2-4. In the first digraph, the subject initially took the first strategy, but came back from the vertex  $v_2$  to the vertex  $v_1$ , and then took the second strategy until he solved the problem. In the second digraph, the subject initially took the second strategy up to the vertex  $u_3$ , then came back to the vertex  $u_1$  and took the first strategy. These are rather simple examples adding one cycle to each path in Figure 2-2, making the strategy a trail instead of a

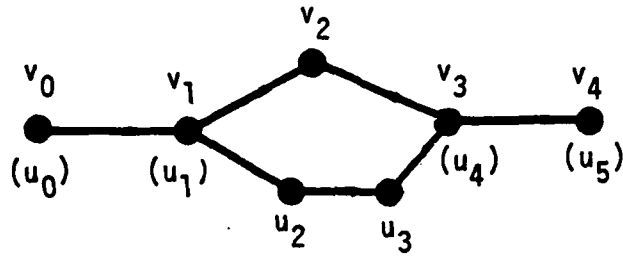

FIGURE 2-1

Example of Two Strategy Case Drawn as a Graph.

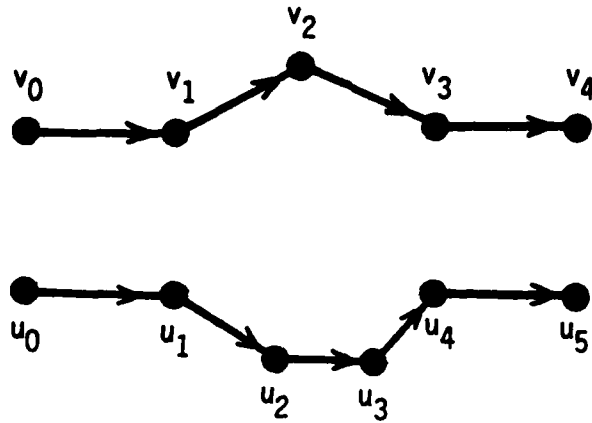

FIGURE 2-2

Two Directed Subgraphs Representing the Two Strategies.

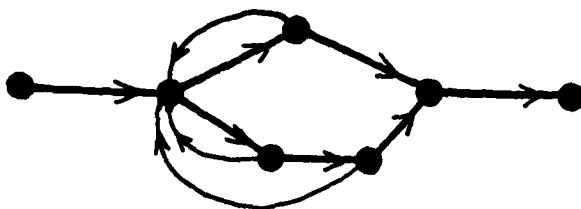

FIGURE 2-3

Digraph Including Two Loops and a Cycle Representing the Subject's Faltering.

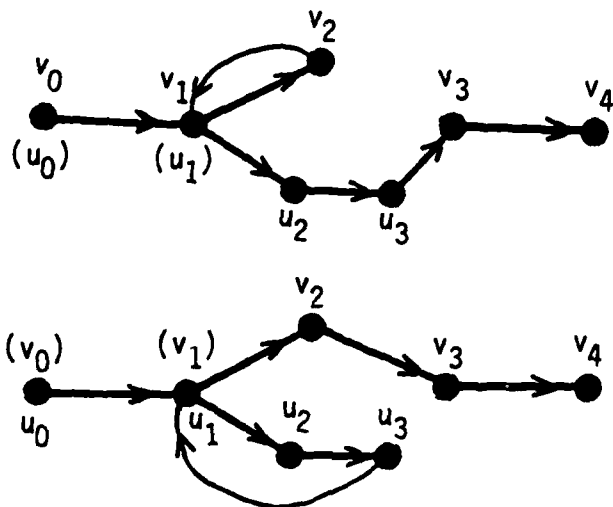

FIGURE 2-4

Two Examples of Directed Subgraphs Representing the Subject's Faltering.

path. We can conceive of more complex examples, however, in which the subject traverses several cycles repeatedly in a single walk, for instance.

So far in our graphs all the vertices are those included in either the first or the second, or both, of the two directed subgraphs of Figure 2-2, which represent the two successful strategies for solving the problem. In our cognitive process, however, we often choose wrong strategies which do not lead to the solution of the problem. Figure 2-5 illustrates such situations, in which hollow circles are added to the solid circles of Figure 2-1, and dashed arcs are added to imply additional paths, which represent wrong strategies. Two examples of such unsuccessful strategies are illustrated in Figure 2-6. In the first subgraph, the subject followed the second successful strategy up to the vertex  $u_2$ , and then branched himself to a subsequence of two subprocesses which led him to a "dead end." The second subgraph illustrates a similar case in which the subject followed the second successful strategy up to the vertex  $u_3$ , and then followed a "dead end" subsequence of two subprocesses.

If the subject took a wrong strategy and found out he could not solve the problem if he sticks to that strategy, he may give up, or he may come back to a previous point in the path and try another strategy. To illustrate this latter situation, additional arcs are necessary in the graph of Figure 2-5. In Figure 2-7, some dotted arcs are added to imply new cycles which the subject may follow when he "comes back." Two examples of such trails are given in Figure 2-8. In the first example, the trail indicates that the subject branched himself to a wrong strategy after he reached the vertex  $u_2$  of the second successful strategy,

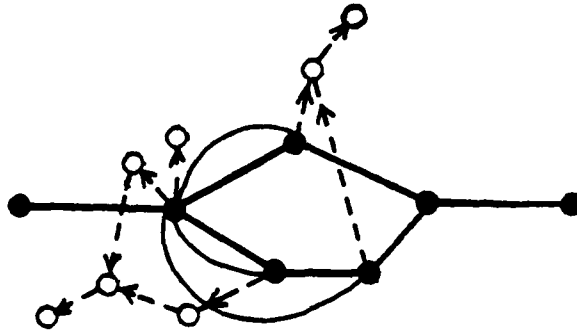

FIGURE 2-5

Digraph Added by Unsuccessful Strategies  
(Dashed Line).

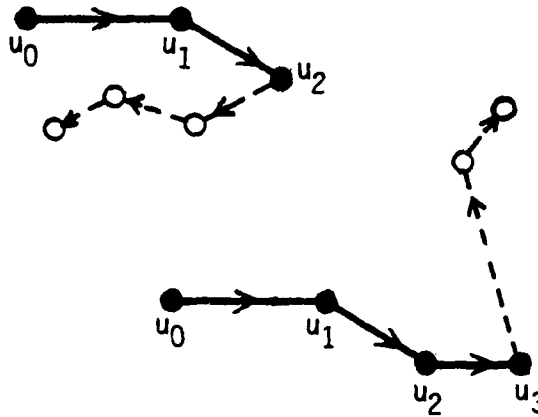

FIGURE 2-6

Two Examples of Unsuccessful Strategies.

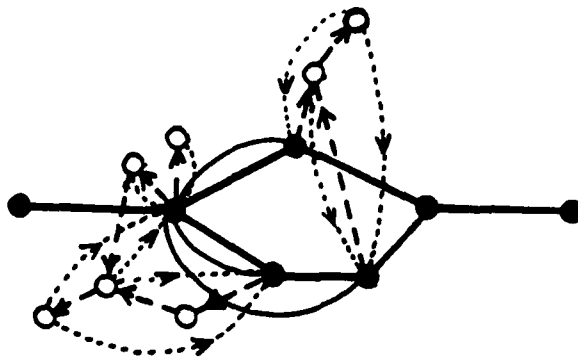

FIGURE 2-7

Digraph Added by Loops and Cycles Representing the Subject's Faltering after He Has Taken Unsuccessful Strategies.

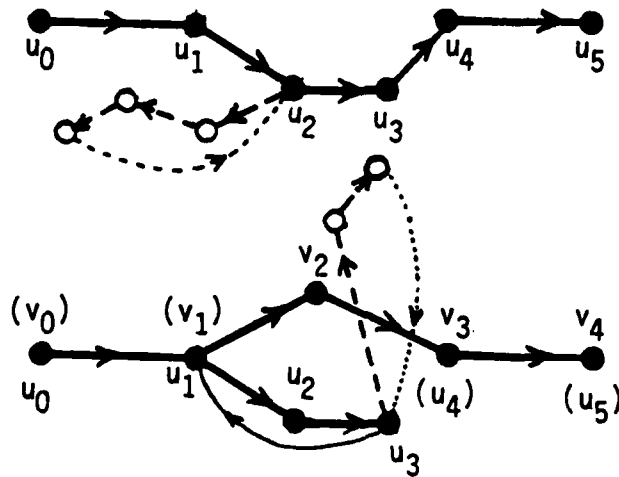

FIGURE 2-8

Two Trails Representing the Subject's Faltering when He Has Taken Unsuccessful Strategies.

followed the path until he reached the "dead end," and then came back to  $u_2$  and followed the rest of the second successful strategy. In the second example, the subject followed up to the vertex  $u_3$  of the second successful strategy, branched himself to a wrong strategy, followed the path to the "dead end," and came back to  $u_3$ , went back to the vertex  $u_1$  ( $= v_1$ ), and then took the first successful strategy until he solved the problem.

We have seen just a small number of examples of conceptualizing the cognitive processes involved in problem solving, and there are a great many other varieties of paths, trails, and walks which might represent a particular subject's cognitive process. The subject may walk the same cycles over and over again, for example, or he may stop at, say, the vertex  $v_2$  in the path representing the first successful strategy and then not proceed, and so forth. In any case, graphic representation illustrated in this section will benefit us in systematizing those complex situations.

### III Differential Strategy Tree

As was referred to in the first section, latent trait theory relates the subject's behavior to his position in the latent space. In problem solving, his behavior is observed in terms of the degree of attainment toward the solution of the problem.

It is obvious that following those cycles presented in Figures 2-3 and 2-7 itself will not directly improve the subject's degree of attainment toward the solution of the problem. For this reason, as far as

we consider the degree of attainment toward the solution, we can more or less ignore the subject's traversing on cycles. In other words, the things that count are the paths in those graphs, rather than trails or walks which may include one or more cycles. Thus the graph of Figure 2-7 may be reduced to the one presented in Figure 3-1. This implies that, when we consider the subject's degree of attainment toward the solution, the first trails in Figures 2-4 and 2-8 are treated as equivalent to the second path in Figure 2-2, and the second trails in those two figures are treated as equivalent to the first path in Figure 2-2.

We also notice that even the same subject in exactly the same problem solving situation may take different strategies, if it is given repeatedly. Thus even if his latent trait and the given situation stay the same, he may have a higher probability of solving the problem when he chooses one strategy in preference to the others. In other words, there is no reason to assume that for a given individual of trait  $\theta$  the probability of success stays the same when he chooses different successful strategies. In the illustration presented in the preceding section, the probability with which the subject of trait  $\theta$  solves the problem using the first successful strategy may not be the same as the one when he uses the second successful strategy, even though the edge  $(v_3 v_4)$  is the same as the edge  $(u_4 u_5)$ .

The above observation suggests that, as far as we consider the degree of attainment and its corresponding operating characteristic, it may be more convenient to represent the set of all strategies as a tree. Figure 3-2 presents such a tree obtained from the graph in Figure 3-1 for

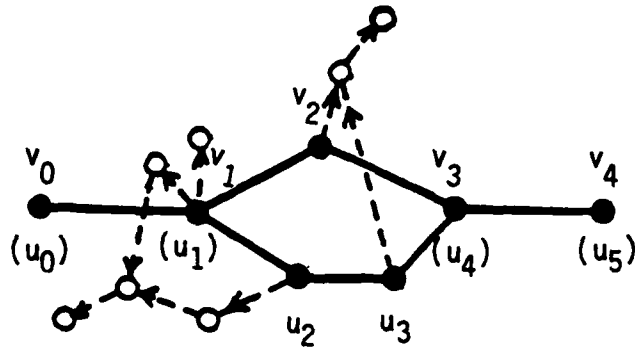

FIGURE 3-1

Digraph Excluding All Cycles.

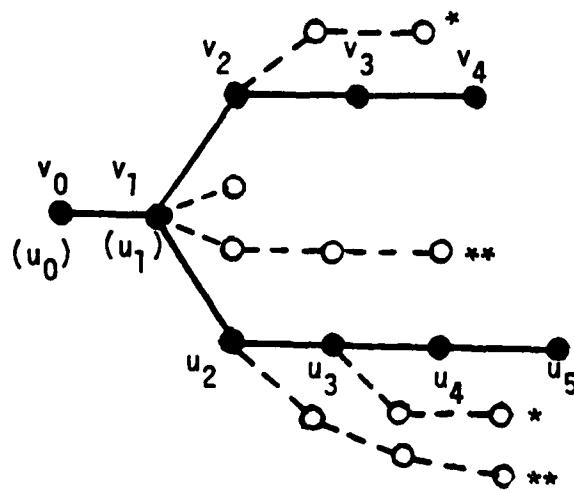

FIGURE 3-2

Differential Strategy Tree Including Both Successful and Unsuccessful Strategies.

the example discussed in the preceding section. Note that not only are the two points  $v_4$  and  $u_5$  in Figure 3-2 the same point in the original graph, Figure 3-1, but also the two hollow circles marked with \* in Figure 3-2 are a single point in Figure 3-1, and so are the two marked with \*\*. Hereafter, we shall call this kind of tree the differential strategy tree. It is a kind of directed graph which contains several paths representing different strategies, joining a common initial endpoint with the other distinct endpoints. We may call this initial point a nothing point, indicating that, "nothing has been accomplished yet." We may call the other endpoints for the successful strategies solution points, meaning, that the "solution has been reached." Since no one can surpass a solution point, it also represents a hypothesized attainment score which no one can obtain.

In theory, we should be able to estimate the operating characteristic for each of the subprocesses in Figure 3-2, which are represented by solid or dashed edges, if appropriate models are discovered. In practice, however, the development of such a model, or models, and its validation will involve much more complicated problems, if, at the initial stage, we include unsuccessful strategies in addition to the successful strategies. For this reason, here we shall consider models for successful strategies only, and solely use the information related to the successful strategies. When some model thus constructed has been validated, we can proceed to explore the operating characteristics of the various subprocesses of unsuccessful strategies, in a way similar to that of estimating the plausibility function of each distractor of the multiple-choice test item

after we have estimated the operating characteristic of the correct answer (cf. Samejima, ONR Final Report, 1981). Thus the path representing the first unsuccessful strategy in Figure 3-2 is treated here as equivalent to the path  $v_0 v_1 v_2$  in the first successful strategy, those representing the second and third unsuccessful strategies to the path  $v_0 v_1$  in the first successful strategy, the path for the fourth unsuccessful strategy to the path  $u_0 u_1 u_2 u_3$  in the second successful strategy, and the one for the fifth to the path  $u_0 u_1 u_2$  in the second successful strategy.

The example we have observed is simple and easy. In reality, however, we should expect more complicated differential strategy trees. Figures 3-3 and 3-4 present another, a little more complicated example of the digraph and corresponding differential strategy tree, in which only successful strategies are drawn. Thus in our second example, we have five successful strategies and five solution points.

#### IV A General Model for Differential Strategies

Let  $w$  denote the number of successful strategies for solving the problem  $g$ . This number equals the number of solution points in the differential strategy tree, which was illustrated in the preceding section. Each of those  $w$  strategies consists of  $m_{g_i}$  ( $i = 1, 2, \dots, w$ ) subprocesses, and they are represented by the vertices, excluding the first and last, in the digraphs and in the differential strategy trees presented in the previous two sections. In the example which was first presented and discussed in Section 2,  $w = 2$ ,  $m_{g_1} = 3$  and  $m_{g_2} = 4$ , and the subprocesses are represented by four edges,  $(v_0 v_1)$ ,  $(v_1 v_2)$ ,  $(v_2 v_3)$

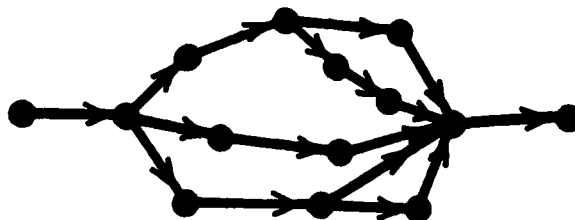

FIGURE 3-3

Another Example of Digraph Representing Five Successful Strategies.

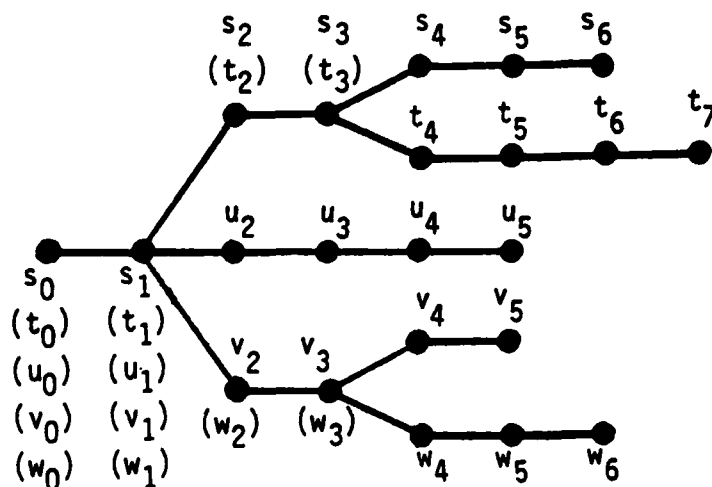

FIGURE 3-4

Differential Strategy Tree of the Second Example Including Successful Strategies Only.

and  $(v_3 v_4)$ , in the path  $v_0 v_1 v_2 v_3 v_4$  representing the first successful strategy, and by five edges,  $(u_0 u_1)$ ,  $(u_1 u_2)$ ,  $(u_2 u_3)$ ,  $(u_3 u_4)$  and  $(u_4 u_5)$ , in the path  $u_0 u_1 u_2 u_3 u_4 u_5$  which represents the second successful strategy. Hereafter, we shall call this example Example 1. It is fairly common that in the original digraph some subprocesses are shared by two or more different strategies, as we can see in Example 1, i.e.,  $(v_0 v_1) = (u_0 u_1)$  and  $(v_3 v_4) = (u_4 u_5)$ .

Let  $y_{gi}$  be the attainment score indicating the degree of attainment of the subject's performance toward the solution of the problem  $g$ , which takes on integers 0 through  $m_{gi}$  when the subject chooses the strategy  $i$ . Figure 4-1 presents several attainment scores assigned to trails which were taken from Example 1. Also Figure 4-2 shows the attainment scores assigned to each edge of the differential strategy tree of the other example, which was presented at the end of Section 3. Hereafter, we shall call this other example Example 2.

A general model for differential strategies concerns the assignment of an operating characteristic to each attainment score  $y_{gi}$  of each of the  $w$  strategies  $i$  for solving the problem  $g$ . By such an operating characteristic we mean the conditional probability with which the subject of trait  $\theta$  chooses the strategy  $i$  and obtains the attainment score  $y_{gi}$ . We notice, however, that in general, if the subject's performance stopped before branching, there is no way to decide which of the two or more strategies he would have taken. This fact is well represented in the differential strategy tree. For example, in Figure 3-4,  $(s_0 s_1)$ ,  $(t_0 t_1)$ ,  $(u_0 u_1)$ ,  $(v_0 v_1)$  and  $(w_0 w_1)$  are a single edge before

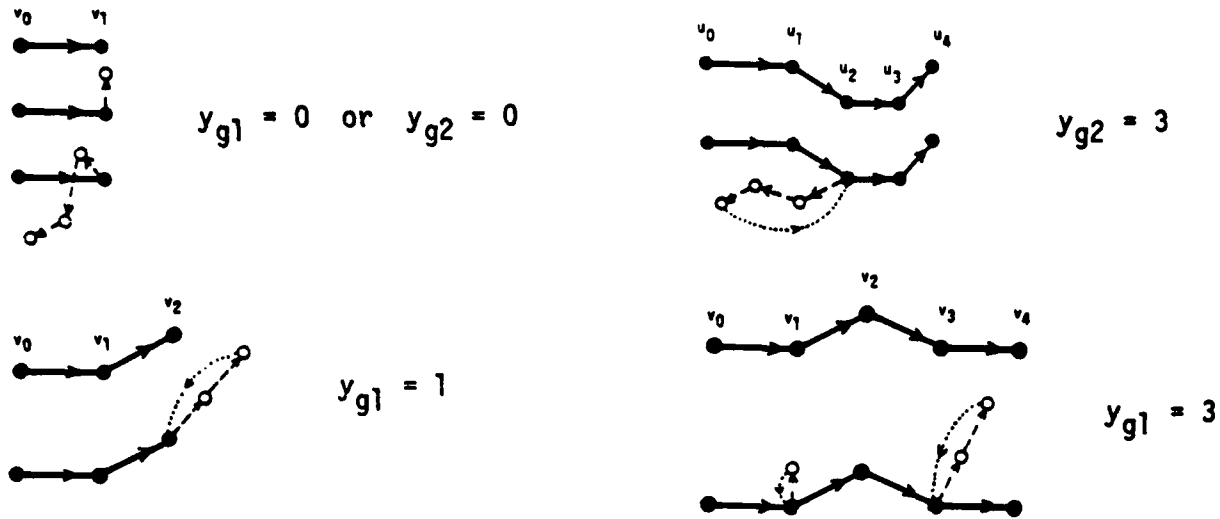

FIGURE 4-1

Examples of Attainment Scores Given to Different Subgraphs in Example 1.

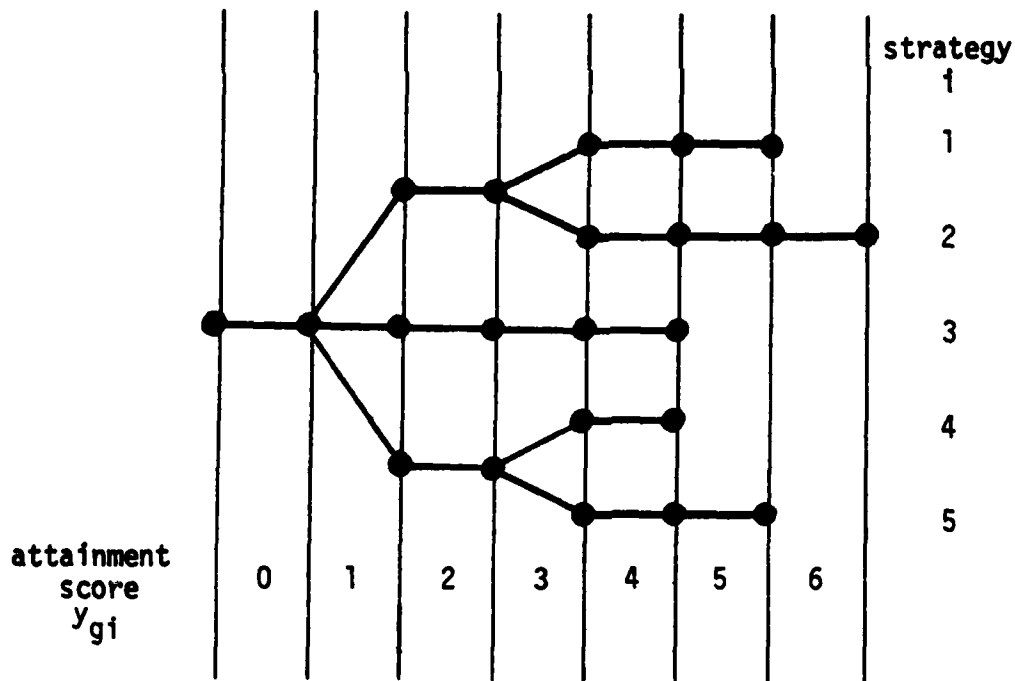

FIGURE 4-2

Attainment Scores Assigned to Each Line of the Differential Strategy Tree in Example 2.

the first branching, and as long as the subject's performance stays with this subprocess he could be heading for any one of the five successful strategies. We can also say the same for the edge which is both  $(s_1 s_2)$  and  $(t_1 t_2)$ , for the one which is both  $(v_1 v_2)$  and  $(w_1 w_2)$ , and so forth. Thus we must assign a single operating characteristic for each edge of the differential strategy tree. Since each edge represents a union of one or more attainment scores, the operating characteristic is to be assigned to each union. For instance, following an appropriate model, a single operating characteristic will be assigned to the union of  $y_{gi} = 0$  for  $i = 1, 2, 3, 4, 5$ , and the same model will provide us with an operating characteristic solely for  $y_{g4} = 3$ , and so on. For convenience, we shall choose the smallest  $i$  in each union, and let  $y_{gsi}^*$  denote such a union with  $s$  for the actual attainment score. In Example 2, for instance,

$y_{g01}^* = (y_{g1}=0) \cup (y_{g2}=0) \cup (y_{g3}=0) \cup (y_{g4}=0) \cup (y_{g5}=0)$ , and  $y_{g34}^* = (y_{g4}=3)$ , and none of the four unions,  $y_{g02}^*$ ,  $y_{g03}^*$ ,  $y_{g04}^*$  and  $y_{g05}^*$ , exists.

Let  $M_{y_{gsi}^*}(\theta)$  denote the conditional probability with which the subject of trait  $\theta$  obtains  $s$  as his attainment score in one of the strategies which belongs to  $y_{gsi}^*$ , with the joint condition that he has already obtained the score  $s-1$ . Since there is no preceding attainment score for  $y_{gi} = 0$ , and  $y_{g01}^*$  is the union of  $y_{gi} = 0$  for all the  $w$  strategies, the attainment function  $M_{y_{g01}^*}(\theta)$  takes on unity throughout the whole range of  $\theta$ . On the other hand, since  $y_{gi} = m_{gi}+1$  is a hypothesized attainment score which is higher than the full score  $m_{gi}$ , the attainment function  $M_{y_{g(m_{gi}+1)i}^*}(\theta)$  assumes zero for the entire range of  $\theta$  for each of the  $w$  strategies. Thus we can write

$$(4.1) \quad M_{y_{gsi}^*}(\theta) \begin{cases} = 1 & i = 1, & s = 0 \\ = 0 & i = 1, 2, \dots, w, & s = m_{gi} + 1. \end{cases}$$

Note that in (4.1) the first line indicates a single function for the union of  $y_{gi} = 0$  for  $i = 1, 2, \dots, w$ , while the second line indicates  $w$  separate functions for  $i = 1, 2, \dots, w$ .

Hereafter, we shall assume that each attainment function  $M_{y_{gsi}^*}(\theta)$  is three-times differentiable with respect to  $\theta$ . Note that this assumption does not contradict (4.1).

Let  $P_{y_{gsi}^*}^*(\theta)$  be the conditional probability assigned to the union of attainment scores  $y_{gsi}^*$ , with which the subject of trait  $\theta$  chooses a strategy which belongs to  $y_{gsi}^*$  and obtains the attainment score  $s$  or greater. We shall call this function the cumulative operating characteristic of the attainment score union  $y_{gsi}^*$ .

From the definitions of this function and the attainment function  $M_{y_{gsi}^*}(\theta)$ , we can write

$$(4.2) \quad P_{y_{gsi}^*}^*(\theta) = \prod_{k=0}^s M_{y_{gk(*i)}^*}(\theta),$$

where  $*i$  indicates the closest integer less than or equal to  $i$  for which the union of attainment scores exists. In particular, we have

$$(4.3) \quad P_{y_{gsi}^*}^*(\theta) \begin{cases} = 1 & s = 0 \\ = M_{y_{gsi}^*}(\theta) & s = 1 \\ = 0 & s = m_{gi} + 1. \end{cases}$$

Note that the first line of (4.3) indicates a single function for the

union of  $y_{gi} = 0$  for  $i = 1, 2, \dots, w$ , the second line indicates one or more functions depending upon the branching, and the third line indicates the  $w$  separate functions for  $i = 1, 2, \dots, w$ . In Example 1, the second line includes two functions, while in Example 2 it includes three functions.

Let  $A_{y_{gsi}}^*(\theta)$  be the first derivative or the natural logarithm of the cumulative operating characteristic  $P_{y_{gsi}}^*(\theta)$ , that is,

$$(4.4) \quad A_{y_{gsi}}^*(\theta) = \frac{\partial}{\partial \theta} \log P_{y_{gsi}}^*(\theta) .$$

Note that this function is unchanged when  $P_{y_{gsi}}^*(\theta)$  is multiplied by a constant. To be more specific, let  $\psi(\theta)$  be a function defined by

$$(4.5) \quad P_{y_{gsi}}^*(\theta) = c_1 + (c_2 - c_1) \psi(\theta) ,$$

where  $0 \leq c_1 < c_2 \leq 1$ . The first derivative of the natural logarithm of  $P_{y_{gsi}}^*(\theta)$  is given by  $\frac{\partial}{\partial \theta} \log [c_1 + (c_2 - c_1) \psi(\theta)]$ , which equals  $\frac{\partial}{\partial \theta} \log \psi(\theta)$  if, and only if,  $c_1 = 0$ . The formula (4.5) has been observed in a somewhat different context (Samejima, ONR/RR-82-1) where  $P_{y_{gsi}}^*(\theta)$  is replaced by any strictly increasing function of  $\theta$  with zero and unity as its two asymptotes. We have called the four different types of functions derived from (4.5) Types A, B, C and D, depending upon the values of  $c_1$  and  $c_2$ , i.e., the function is of Type A when  $0 = c_1 < c_2 = 1$ ; of Type B when  $0 < c_1 < c_2 = 1$ ; of Type C when  $0 = c_1 < c_2 < 1$ ; and of Type D when  $0 < c_1 < c_2 < 1$ , respectively. This implies that the cumulative operating characteristic of Types A and C may share the same function for

$A_{y_{gsi}^*}^*(\theta)$ , and we can say the same for those of Types B and D. The necessary and sufficient condition that  $M_{y_{gsi}^*}(\theta)$  be strictly increasing in  $\theta$  is that the inequality

$$(4.6) \quad A_{y_{gsi}^*}^*(\theta) > A_{(y_{g(s-1)}^*)(*i)}^*(\theta) \quad s = 1, 2, \dots, (m_{gi}+1)$$

holds almost everywhere with respect to  $\theta$ .

The operating characteristic,  $P_{y_{gsi}^*}(\theta)$ , defined for the union of the attainment scores  $Y_{gsi}^*$  is given by

$$(4.7) \quad P_{y_{gsi}^*}(\theta) = P_{y_{gsi}^*}^*(\theta) - \sum_{j^*} P_{y_{g(s+1)j}^*}^*(\theta),$$

where  $\sum_{j^*}$  indicates the summation over all the strategies  $j$  branching from the point which lies immediately after the line representing  $y_{gsi}^*$ .

This operating characteristic can be considered as the likelihood function in estimating the subject's latent trait  $\theta$ . If there are more than one problem satisfying the conditional independence of the attainment scores across the different strategies, given  $\theta$ , the maximum likelihood estimation of the subject's latent trait can be performed on the basis of the response pattern  $V$ , such that

$$(4.8) \quad V = (y_{1i_1}, y_{2i_2}, \dots, y_{gi_g}, \dots, y_{ni_n})'$$

for the  $n$  problem solving tasks, where  $i_g$  is a strategy for solving the problem  $g$  and  $y_{gi_g}$  is the attainment score when the subject chooses

the strategy  $i_g$  for solving the problem  $g$ . Let  $P_V(\theta)$  be the operating characteristic of the specific response pattern  $V$ . We can write

$$(4.9) \quad P_V(\theta) = \prod_{*} P_{y_{gsi}^*}(\theta) ,$$

where  $\prod_{*}$  indicates the multiplication over every union  $y_{gsi}^*$  to which an element of  $V$  belongs.

It is beneficial to search for a family of models which provide us with a unique maximum for every possible response pattern given by (4.8). This can be done as a generalization of the unique maximum condition proposed for the graded response model (cf. Samejima, 1969, 1972). Two of such models will be proposed and observed in Section 5.

The basic function,  $A_{y_{gsi}^*}(\theta)$ , for the union of attainment scores  $y_{gsi}^*$  is defined by

$$(4.10) \quad A_{y_{gsi}^*}(\theta) = \frac{\partial}{\partial \theta} \log P_{y_{gsi}^*}(\theta) .$$

The maximum likelihood estimate,  $\hat{\theta}_V$ , of the subject's latent trait based upon his response pattern is given as the solution of the likelihood equation such that

$$(4.11) \quad \begin{aligned} \frac{\partial}{\partial \theta} \log P_V(\theta) &= \sum_{*} \frac{\partial}{\partial \theta} \log P_{y_{gsi}^*}(\theta) \\ &= \sum_{*} A_{y_{gsi}^*}(\theta) , \end{aligned}$$

where  $\sum_{*}$  indicates the summation over every union  $y_{gsi}^*$  to which an

element of  $V$  belongs. A sufficient condition that a unique modal point exists for the likelihood function  $P_V(\theta)$  of each and every response pattern  $V$  is that this basic function is strictly decreasing in  $\theta$  with non-negative and non-positive values as its two asymptotes, for every union  $y_{gs1}^*$ . This can be shown in the same way that we did for the basic function  $A_{x_g}(\theta)$  of the graded item score  $x_g$  (cf. Samejima, 1969). For brevity, sometimes we call this condition the unique maximum condition.

Multi-correct and multi-incorrect responses have been discussed briefly (Samejima, 1972, Sections 3.4 and 4.2), and it has been pointed out that all those response categories can be syndrome categories, i.e., response categories whose operating characteristics satisfy the unique maximum condition (Samejima, 1969, 1972). Those cases are included in Situation B (Samejima, 1972, Section 3.2), where there exist more than one response category whose operating characteristic is of Type (i) (or of Type (ii)), and, at least, one response category whose operating characteristic is of Type (ii) (or of Type (i)), and, in addition there may be one or more response categories whose operating characteristics are of Type (iii). It should be recalled that by Types (i), (ii) and (iii) we mean strictly increasing, strictly decreasing, and unimodal operating characteristics which satisfy the unique maximum condition. In Situation B, the sum total of the upper asymptotes of all the operating characteristics of Type (i) should equal unity. This implies that, as  $\theta$  tends to positive infinity, the operating characteristic of each correct answer approaches a finite positive value less than unity. We notice that such operating characteristics belong to the Type C model (Samejima, ONR/RR-82-1).

Similarities between the differential strategies in problem solving and the multi-correct responses in testing are obvious. If we consider two or more different strategies which lead to the solution of the problem as two or more different answers to a question, then they will be treated as multi-correct responses. We can see that the concept of multi-correct responses can be transferred to differential strategies, when there exist more than one successful strategy in solving a problem.

#### V Homogeneous Case

The Homogeneous case of the graded response level has been developed and discussed (Samejima, 1972) as a generalization of a family of models on the dichotomous response level. Sufficient conditions that a model provides us with a unique modal point for the likelihood function of each and every response pattern have been investigated. In the homogeneous case, a sufficient condition is that, for an arbitrary item score  $x_g$  ( $\neq 0$ ), the cumulative operating characteristic  $P_{x_g}^*(\theta)$  is of Type A, i.e., strictly increasing in  $\theta$  with zero and unity as its two asymptotes, and its asymptotic basic function,  $\tilde{A}_{x_g}(\theta)$ , which is defined by

$$(5.1) \quad \tilde{A}_{x_g}(\theta) = \frac{\partial}{\partial \theta} \left[ \log \left\{ \frac{\partial}{\partial \theta} P_{x_g}^*(\theta) \right\} \right] ,$$

is strictly decreasing in  $\theta$ . The satisfaction of this sufficient condition also implies two desirable features of the model such that: 1) the operating characteristic of each graded item score of each item has a single modal point, and 2) those modal points for a single item are

arranged in the same order as the item score itself. The normal ogive and logistic models, which have been generalized from the corresponding models on the dichotomous response level, are two examples of the models which satisfy the above sufficient condition.

These models of the homogeneous case on the graded response level can be generalized to provide us with those which belong to the general model of differential strategies. Let  $\Psi(\theta)$  be a function of Type A. We shall consider the cumulative operating characteristic,  $P_{y_{gsi}^*}^*(\theta)$ , of the union of attainment categories  $y_{gsi}^*$  such that

$$(5.2) \quad P_{y_{gsi}^*}^*(\theta) = \beta_{y_{gsi}^*} \Psi(\theta - \alpha_{y_{gsi}^*}) ,$$

where  $\alpha_{y_{g0i}^*}$  is negative infinity,  $\alpha_{y_{g(m+1)i}^*}$  is positive infinity for  $i = 1, 2, \dots, w$ , and the values of  $\alpha_{y_{gsi}^*}$  are ordered in the same way as those of  $s$ , for every strategy, and  $\beta_{y_{gsi}^*}$  is a constant which satisfies

$$(5.3) \quad \sum_{j^*} \beta_{y_{gsj}^*} = \beta_{y_{g(s-1)i}^*} ,$$

with  $\sum_{j^*}$  indicating the summation over all the strategies  $j$  branching from the point of the differential strategy tree which is located right after the line representing the union  $y_{g(s-1)i}^*$ . From (5.3) it is obvious that, as far as there is no branching,  $\beta_{y_{gsi}^*} = \beta_{y_{g(s-1)i}^*}$ .

A sufficient condition that the model satisfies the unique maximum condition is: 1) that the values of the constant  $\alpha_{y_{gsj}^*}$  are the same for

all the strategies  $j$  which branch from the vertex located immediately after the edge representing  $y_{gsi}^*$ , and 2) that we have

$$(5.4) \quad \frac{\partial}{\partial \theta} \left[ \log \left\{ \frac{\partial}{\partial \theta} \psi(\theta) \right\} \right] < 0$$

almost everywhere in the domain of  $\theta$ . To prove this, we obtain from (4.7), (5.2), (5.3) and the definition of the basic function  $A_{y_{gsi}^*}(\theta)$ , which was given by (4.10),

$$(5.5) \quad \begin{aligned} A_{y_{gsi}^*}(\theta) &= \frac{\partial}{\partial \theta} \log P_{y_{gsi}^*}(\theta) \\ &= \frac{\partial}{\partial \theta} \log \left[ \beta_{y_{gsi}^*} \psi(\theta - \alpha_{y_{gsi}^*}) - \sum_{j^*} \beta_{y_{g(s+1)j}^*} \psi(\theta - \alpha_{y_{g(s+1)j}^*}) \right] \end{aligned}$$

where  $\sum_{j^*}$  indicates the summation over all the strategies  $j$  branching from the vertex which lies immediately after the line representing the union  $y_{gsi}^*$ . By virtue of the first condition, we can rewrite (5.5) in the form

$$(5.6) \quad \begin{aligned} A_{y_{gsi}^*}(\theta) &= \frac{\partial}{\partial \theta} \log \left[ \beta_{y_{gsi}^*} \left\{ \psi(\theta - \alpha_{y_{gsi}^*}) - \psi(\theta - \alpha_{y_{g(s+1)j}^*}) \right\} \right] \\ &= \frac{\partial}{\partial \theta} \log \left\{ \psi(\theta - \alpha_{y_{gsi}^*}) - \psi(\theta - \alpha_{y_{g(s+1)j}^*}) \right\}. \end{aligned}$$

We notice that, if we replace  $y_{gsi}^*$  by the graded item score  $x_g$  and use  $\psi(\theta - \alpha_{x_g})$  as the cumulative operating characteristic  $P_{x_g}^*(\theta)$ , the last form of (5.6) is identical with the basic function of the graded item score, and the left hand side of (5.4) is identical with the corresponding asymptotic basic function. Thus we can say that all the unions,  $y_{gsi}^*$ ,

are equivalent to syndrome response categories (cf. Samejima, 1972, Section 5.2), and a unique maximum is assured for every possible response pattern.

If, for example,  $\Psi(\theta)$  is a normal ogive function or a logistic distribution function, then (5.4) is satisfied (Samejima, 1972, Section 5.2), and we can develop the normal ogive model and the logistic model in the context of the general model for differential strategies, and both of them satisfy the unique maximum condition. In these two models, the cumulative operating characteristics are defined by

$$(5.7) \quad P_{y_{gsi}^*}^*(\theta) = \beta_{y_{gsi}^*} (2\pi)^{-1/2} \int_{-\infty}^{a_g(\theta - b_{y_{gsi}^*})} e^{-u^2/2} du$$

and

$$(5.8) \quad P_{y_{gsi}^*}^*(\theta) = \beta_{y_{gsi}^*} [1 + \exp\{-Da_g(\theta - b_{y_{gsi}^*})\}]^{-1},$$

respectively, where  $a_g (> 0)$  is the discrimination parameter specific for each problem  $g$ ,  $b_{y_{gsi}^*}$  is a difficulty parameter defined for each union of attainment scores, with  $b_{y_{g0i}^*} = -\infty$  and  $b_{y_{g(n_g+1)i}^*} = \infty$  and all those values are arranged in the same order as  $s$  with respect to each strategy, and  $D$  in (5.8) is a scaling factor which assumes 1.7 to retain the same set of parameter values as those in the normal ogive model.

For the purpose of illustration, we shall consider a differential strategy tree shown in Figure 5-1, which was taken from Example 1 given in

Section 1 and has only two successful strategies, or  $w = 2$ . Note, however, that this tree may represent either one of the digraphs shown in Figure 5-2. Figure 5-3 presents the set of ten cumulative operating characteristics  $P_{y_{gsi}^*}^*(\theta)$ , with  $a_g = 1.00$ ,  $b_{y_{g11}^*} = b_{y_{g12}^*} = -2.50$ ,  $b_{y_{g21}^*} = -1.00$ ,  $b_{y_{g31}^*} = 0.50$ ,  $b_{y_{g22}^*} = -1.80$ ,  $b_{y_{g32}^*} = 0.00$  and  $b_{y_{g43}^*} = 2.00$ ,  $\beta_{y_{g11}^*} = 0.60$  and  $\beta_{y_{g12}^*} = 0.40$ . The cumulative operating characteristic for  $y_{g01}^*$  is drawn by a solid line, and the three cumulative operating characteristics for the first strategy are drawn by dotted lines, the four for the second strategy by dashed lines, and the two for  $y_{g51}^*$  and  $y_{g62}^*$  coincide with the abscissa. Figure 5-4 presents the corresponding operating characteristics, in which all the modal points except for the negative and positive infinities are shown.

#### VI Single Strategy Case

Suppose that in solving the problem  $g$  there is only one successful strategy. Such a single strategy case can be considered as a special case of the multiple strategy case in which  $w = 1$ . The union of attainment scores, therefore, includes one and only one attainment score, and we can write

$$(6.1) \quad y_{gsi}^* = (y_g = s) ,$$

where  $y_g$  is the attainment score of the unique successful strategy. Thus the three functions, i.e., the attainment function, the cumulative operating characteristic and the operating characteristic, are defined for each attainment score, rather than the union of attainment scores.

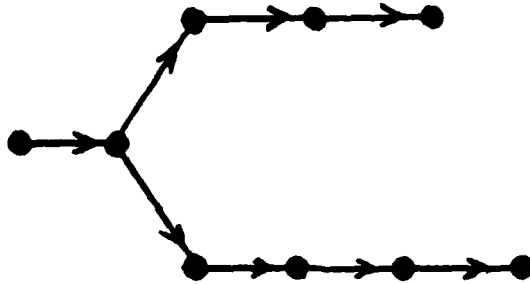

FIGURE 5-1

Differential Strategy Tree of Two Strategies Taken from Example 1.

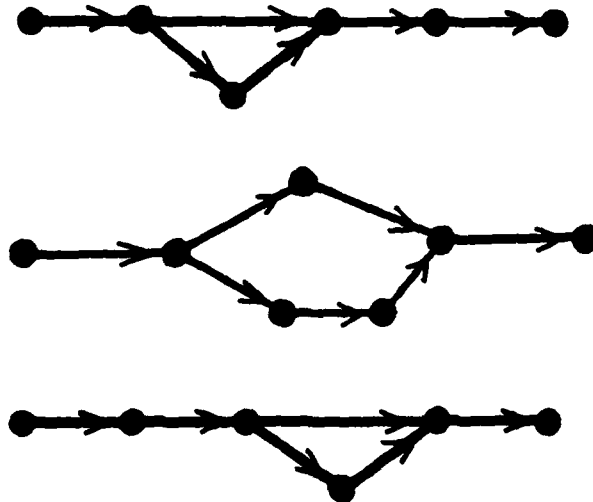

FIGURE 5-2

Three Digraphs Whose Differential Strategy Tree Is Given by Figure 5-1.

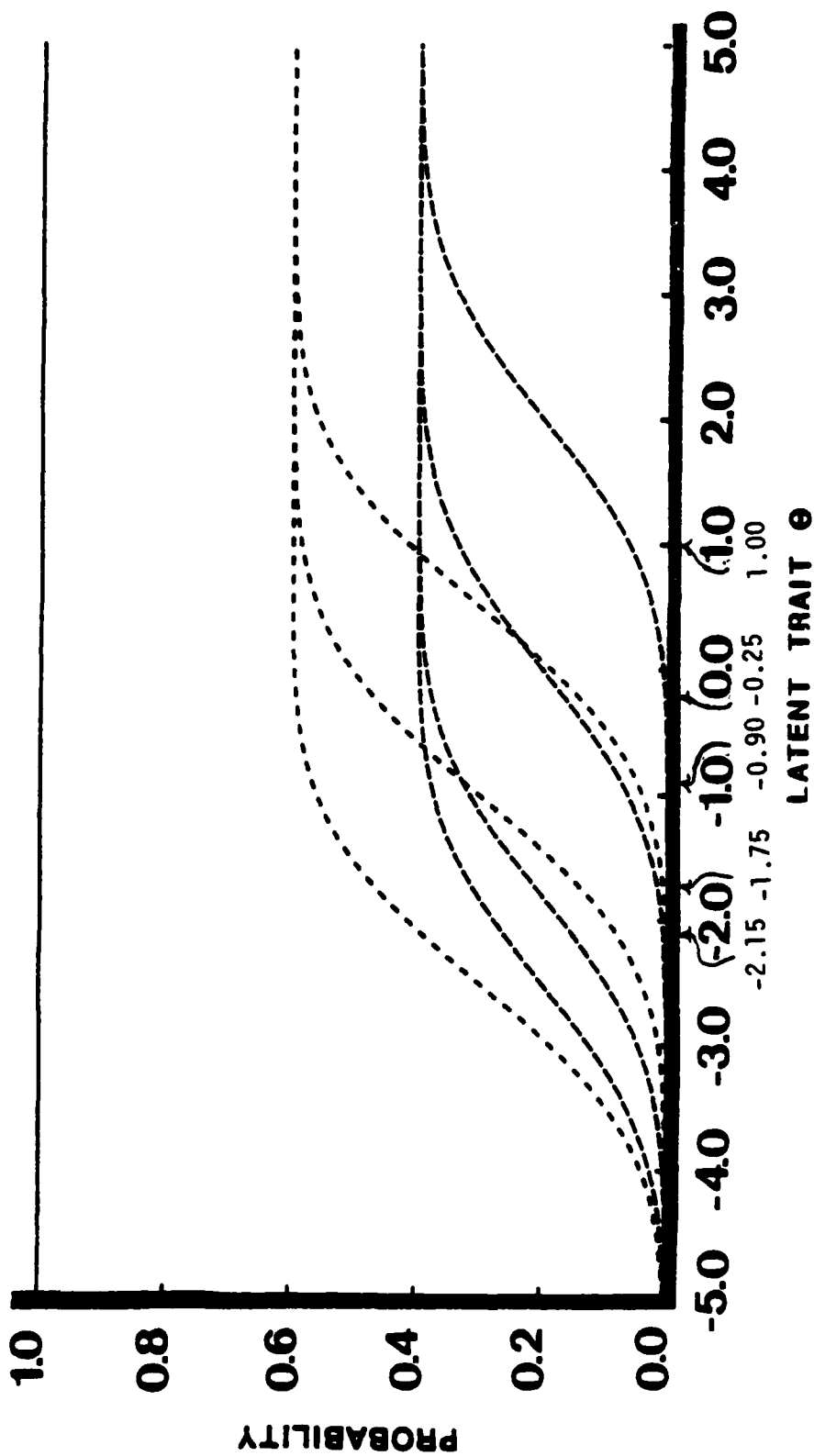

FIGURE 5-3

Cumulative Operating Characteristic of the Union of  $(y_{g1} = 0)$  and  $(y_{g2} = 0)$  (Solid Line), Those of  $(y_{g1} = 1)$ ,  $(y_{g1} = 2)$  and  $(y_{g1} = 3)$ , Respectively (Dotted Line), and Those of  $(y_{g2} = 1)$ ,  $(y_{g2} = 2)$ ,  $(y_{g2} = 3)$  and  $(y_{g2} = 4)$ , Respectively (Dashed Line).

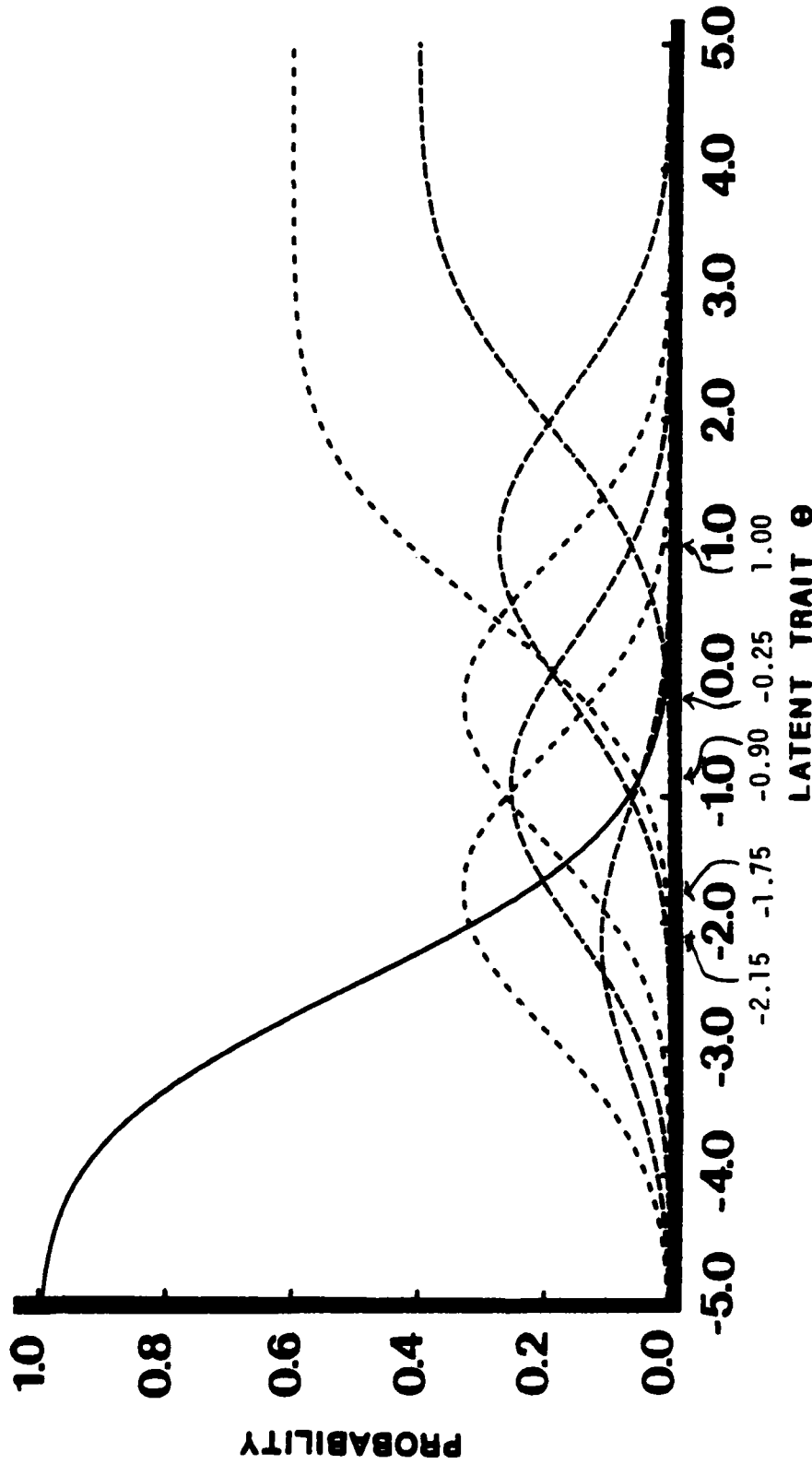

FIGURE 5-4

Operating Characteristic of the Union of  $(y_{g1} = 0)$  and  $(y_{g2} = 0)$  (Solid Line), Those of  $(y_{g1} = 1)$ ,  $(y_{g1} = 2)$  and  $(y_{g1} = 3)$ , Respectively (Dotted Line), and Those of  $(y_{g2} = 1)$ ,  $(y_{g2} = 2)$ ,  $(y_{g2} = 3)$  and  $(y_{g2} = 4)$ , Respectively (Dashed Line).

Let  $M_{y_g}(\theta)$ ,  $P_{y_g}^*(\theta)$  and  $P_{y_g}(\theta)$  denote these three functions for the single strategy case. We can change the formulas (4.1), (4.2), (4.3), (4.7), (4.8) and (4.9) into much simplified forms, such that

$$(6.2) \quad M_{y_g}(\theta) \begin{cases} = 1 & y_g = 0 \\ = 0 & y_g = m_g + 1 \end{cases} ,$$

$$(6.3) \quad P_{y_g}^*(\theta) = \prod_{j=0}^{y_g} M_j(\theta) \quad y_g = 0, 1, \dots, m_g, (m_g + 1) ,$$

$$(6.4) \quad P_{y_g}^*(\theta) \begin{cases} = 1 & y_g = 0 \\ = M_{y_g}(\theta) & y_g = 1 \\ = 0 & y_g = m_g + 1 \end{cases} ,$$

$$(6.5) \quad P_{y_g}(\theta) = P_{y_g}^*(\theta) - P_{(y_g+1)}^*(\theta) \quad y_g = 0, 1, \dots, m_g ,$$

$$(6.6) \quad V = (y_1, y_2, \dots, y_g, \dots, y_n)'$$

and

$$(6.7) \quad P_V(\theta) = \prod_{y_g \in V} P_{y_g}(\theta) ,$$

where  $m_g$  indicates the number of the subprocesses involved in solving the problem  $g$ .

We notice that these results are identical with those formulas for the graded response model (Samejima, 1972), with the replacement of the item score  $x_g$  by the attainment score  $y_g$ . Many findings concerning

the graded response model, therefore, can directly be applied for the single strategy case.

Let  $A_{y_g}^*(\theta)$  be the first partial derivative of the natural logarithm of  $P_{y_g}^*(\theta)$ , such that

$$(6.8) \quad A_{y_g}^*(\theta) = \frac{\partial}{\partial \theta} \log P_{y_g}^*(\theta) \quad y_g = 0, 1, \dots, (m_g + 1).$$

It has been shown that the necessary and sufficient condition that

$M_{y_g}(\theta)$  be strictly increasing in  $\theta$  is that the inequality

$$(6.9) \quad A_{y_g}^*(\theta) > A_{(y_g-1)}^*(\theta) \quad y_g = 1, 2, \dots, (m_g + 1)$$

holds almost everywhere with respect to  $\theta$  (cf. Samejima, 1967, 1972).

In the homogeneous case  $P_{y_g}^*(\theta)$  has zero and unity as its two asymptotes for  $y_g = 1, 2, \dots, m_g$ , and, furthermore, we can write

$$(6.10) \quad P_g^*(\theta) = P_r^*(\theta - \alpha_{rs}) ,$$

where  $r$  and  $s$  are two arbitrarily selected attainment categories out of 1 through  $m_g$  with  $r < s$ , and  $\alpha_{rs}$  is a positive finite constant. We obtain from (6.8) and (6.10)

$$(6.11) \quad A_g^*(\theta) = A_r^*(\theta - \alpha_{rs}) .$$

From (6.9) and (6.11) it is obvious that a sufficient, though not necessary, condition that  $M_{y_g}(\theta)$  be strictly increasing in  $\theta$  for

$y_g = 1, 2, \dots, m_g$  is that  $A_{y_g}^*(\theta)$  is strictly decreasing in  $\theta$  for an arbitrarily chosen attainment category out of 1 through  $m_g$ . When  $m_g$  tends to positive infinity and  $\alpha_{rs}$  for two adjacent real attainment categories tends to zero, this condition tends to the necessary and sufficient condition, for it requires that

$$(6.12) \quad A_{y_g}^*(\theta) > A_{y_g}^*(\theta + \epsilon)$$

for any small positive value of  $\epsilon$ . Note that this condition is satisfied whenever the unique maximum condition is satisfied. Above all, when the asymptotic basic function,  $\tilde{A}_{y_g}^*(\theta)$ , which is defined by

$$(6.13) \quad \tilde{A}_{y_g}^*(\theta) = \left[ \frac{\partial^2}{\partial \theta^2} P_{y_g}^*(\theta) \right] \left[ \frac{\partial}{\partial \theta} P_{y_g}^*(\theta) \right]^{-1},$$

is strictly decreasing in  $\theta$ , not only  $M_{y_g}(\theta)$  of each subprocess is strictly increasing in  $\theta$ , however finely differentiated it may be, but also a unique maximum is assured for the likelihood function of each and every possible response pattern which consists of such attainment scores of different tasks (cf. Samejima, 1972, Sections 5.1 and 5.2). It has been shown (Samejima, 1967, 1972) that in the normal ogive model and in the logistic model on the graded response level (Samejima, 1969), for example, this condition is satisfied. In the former example, we can write

$$(6.14) \quad P_{y_g}^*(\theta) = (2\pi)^{-1/2} \int_{-\infty}^{a_g(\theta - b_{y_g})} \exp(-u^2/2) du$$

and in the latter

$$(6.15) \quad P_{y_g}^*(\theta) = [1 + \exp\{-Da_g(\theta - b_{y_g})\}]^{-1},$$

where  $a_g$  is the item discrimination parameter and  $b_{y_g}$  is the difficulty parameter for each attainment category  $y_g$ , and  $D$  is a scaling factor which is usually set equal to 1.7 (Birnbaum, 1968). In both models, the upper asymptote of  $M_{y_g}(\theta)$  for  $y_g = 1, 2, \dots, m_g$  is unity, while the lower asymptote is zero in the normal ogive model and  $\exp[-Da_g(b_{y_g} - b_{(y_g-1)})]$  in the logistic model. This lower asymptote in the logistic model depends upon the distance between the difficulty parameters of the two adjacent attainment categories, assuming zero for  $y_g = 1$  and positive numbers less than unity otherwise. In both models,  $M_{y_g}(\theta)$  for  $y_g = 2, 3, \dots, m_g$  tends to unity for the entire range of  $\theta$  as  $b_{y_g}$  approaches  $b_{(y_g-1)}$ , and tends to  $P_{y_g}^*(\theta)$  as  $b_{y_g}$  departs from  $b_{(y_g-1)}$  (cf. Samejima, 1972, Figure 5-2-1).

We shall consider an example of the problem solving task, in which we can assume a single successful strategy. The problem was selected from the thirty paper-and-pencil test items of the LIS Measurement Scale for Non-Verbal Reasoning Ability (Indow and Samejima, 1962, 1966). The test item is called  $D_{2.2}$ , and is shown in Figure 6-1. There are three Japanese words written by English alphabetical letters, "YAMA," "UMI," and "KAWA," which consist of one, and only one, of the seven one-digit numbers, which are shown in the brackets in Figure 6-1. The sum of the

first two words is supposed to equal the third word, and the examinee is expected to find out which letter represents which number.

In solving this problem, we notice that: 1) "I" is added to "A" to produce "A" itself with no carried number added, so "I" must equal 0; 2) a similar result is observed for "A" and "U", but 0 is already assigned to "I", so "U" must be 9; 3) "K" must be greater than "Y" by one, so (Y,K) must be either one of (3,4), (6,7) and (7,8); 4) since 1 must be carried from the second lowest digit to the third, two times "M" must be "W" plus ten, so (M,W) must be either (7,4) or (8,6); 5) combining 3) and 4), since no overlappings are allowed, we we must conclude (Y,K) = (3,4) and (M,W) = (8,6); 6) since 7 is the only remaining number, "A" must be 7. Note that we could reverse 1) 2) 3) to 3) 2) 1), since 3) can be reached independently and it gives a sufficient information to discover 2). Also 4) does not need both 1) and 3), since we can reach it directly from 2). For these reasons, strictly speaking, there are some minor variations in this strategy, and the above problem is not exactly an example of the single strategy case. In spite of those variations, however, our observation tells us that the majority of subjects take the above strategy, probably because 1) is easier to discover than 3), and so forth. Table 6-1 presents the attainment scores and the description of the corresponding subprocess for each score in this example.

It has been reported (Samejima, 1969) that, in their effort of solving this problem in the paper-and-pencil testing situation, as many as 187 subjects out of the total of 883 junior high school students

Y A M A	( 0 3 4 6 7 8 9 )
+ U M I	A I K M U W Y
K A W A	

FIGURE 6-1

Item  $D_{2.2}$  of LIS Measurement Scale of Non-Verbal Ability.

TABLE 6-1

Subprocesses of the Task Involved in Solving Item  $D_{2.2}$  of LIS Measurement Scale of Non-Verbal Ability.

Item Score $x_g$	Attainment Score $y_g$	Subprocess
0	0	(none)
0	1	I = 0      Left: (3 4 6 7 8 9)
1	2	U = 9      Left: (3 4 6 7 8)
1	3	K = Y + 1 (Y,K) = (3,4) or (6,7) or (7,8)
1	4	W = 2M - 10 (M,W) = (7,4) or (8,6)
1	5	M = 8 W = 6 Y = 3 K = 4      Left: (7)
2	6	A = 7

discovered both  $I = 0$  and  $U = 9$  and wrote them down on their sheets, although they did not reach the complete solution of the problem. The number of those subjects is almost as large as that of those who reached the complete answer, i.e., 202. For this reason, using the item score  $x_g$  ( $= 0,1,2$ ), which is shown in the first column of Table 6-1, the operating characteristic has been estimated for each item score using the normal ogive model on the graded response level. The resultant three operating characteristics,  $P_{x_g}(\theta)$  for  $x_g = 0,1,2$ , have been reported, and are reproduced as Appendix. It has also been reported that this result provides us with a good internal consistency which supports the validity of the model.

## VII Discussion and Conclusions

Using digraphs and trees, an attempt was made to give a rationale behind a general model for differential strategies, and some concrete models in the homogeneous case were proposed. The single strategy case was observed as a special case of the multiple strategy case.

A question may arise as to which estimate of the latent trait should be taken if the subject faltered from one strategy to another and did not reach the solution of the problem. One answer to this question may be to take the attainment score of the strategy that he took last, and use its corresponding operating characteristic in estimating his latent trait. An alternative answer may be to compare the resultant estimates of  $\theta$  obtained by choosing the different strategies the subject has taken and select the highest estimate.

The usefulness of the model is yet to be discovered. The example of the item  $D_{2.2}$  of the LIS Measurement Scale provides us, however, with some support for considering cognitive processes in the framework of latent trait theory.

One of the difficulties in any quantification of cognitive data may be their small sample sizes. It will be useful to conduct intensive, observant laboratory studies as a pilot study, and then to use their results in designing more extensive studies, like paper-and-pencil testing, computerized adaptive testing, and so forth, for the purpose of estimating the operating characteristics and eventually the subject's latent trait.

REFERENCES

- [1] Birnbaum, A. Some latent trait models and their use in inferring an examinee's ability. In F. M. Lord and M. R. Novick; Statistical theories of mental test scores. Addison-Wesley, 1968, Chapters 17-20
- [2] Indow, T. and F. Samejima. LIS measurement scale for non-verbal reasoning ability. (With four tests, LIS-P, LIS-C, LIS-S and LIS-U). Tokyo: Nippon Bunka Kagakusha, 1962.
- [3] Indow, T. and F. Samejima. On results obtained by the absolute scaling model and the Lord model in the field of intelligence. Monographs of the Psychological Laboratory on the Hiyoshi Campus, Keio University, 1966, No. 3 (in English).
- [4] Samejima, F. A general model for the operating characteristic of graded item response. Chapel Hill, North Carolina: The L.L. Thurstone Psychometric Laboratory Report, 55, 1967.
- [5] Samejima, F. Estimation of latent ability using a response pattern of graded scores. Psychometrika Monograph, No. 17, 1969.
- [6] Samejima, F. A general model for free-response data. Psychometrika Monograph, No. 18, 1972.

LIST OF ONR TECHNICAL REPORTS AND OTHERS

N00014-77-C-0360

- (1) Samejima, F. Estimation of the operating characteristics of item response categories I: Introduction to the Two-Parameter Beta Method. RR-77-1, 1977.
- (2) Samejima, F. The application of graded response models. Proceedings of the 1977 Computerized Adaptive Testing Conference (D.J. Weiss, Ed.), 28-37, 1977.
- (3) Samejima, F. Future directions for computerized adaptive testing (panel discussion). Proceedings of the 1977 Computerized Adaptive Testing Conference (D.J. Weiss, Ed.), 430-440, 1977.
- (4) Samejima, F. Estimation of the operating characteristics of item response categories II: Further development of the Two-Parameter Beta Method. RR-78-1, 1978.
- (5) Samejima, F. Estimation of the operating characteristics of item response categories III: The Normal Approach Method and the Pearson System Method. RR-78-2, 1978.
- (6) Samejima, F. Estimation of the operating characteristics of item response categories IV: Comparison of the different methods. RR-78-3, 1978.
- (7) Samejima, F. Estimation of the operating characteristics of item response categories V: Weighted Sum Procedure in the Conditional P.D.F. Approach. RR-78-4, 1978.
- (8) Samejima, F. Estimation of the operating characteristics of item response categories VI: Proportioned Sum Procedure in the Conditional P.D.F. Approach. RR-78-5, 1978.
- (9) Samejima, F. Estimation of the operating characteristics of item response categories VII: Bivariate P.D.F. Approach with Normal Approach Method. RR-78-6, 1978.
- (10) Samejima, F. Constant Information Model: A new, promising item characteristic function. RR-79-1, 1979.
- (11) Samejima, F. and P. S. Livingston. Method of moments as the least squares solution for fitting a polynomial. RR-79-2, 1979.

- (12) Samejima, F. Convergence of the conditional distribution of the maximum likelihood estimate, given latent trait, to the asymptotic normality: Observations made through the Constant Information Model. RR-79-3, 1979.
- (13) Samejima, F. A new family of models for the multiple-choice item. RR-79-4, 1979.
- (14) Samejima, F. Constant Information Model on the dichotomous response level. Proceedings of the 1979 Computerized Adaptive Testing Conference (D.J. Weiss, Ed.), 145-163, 1979.
- (15) Samejima, F. Research on the multiple-choice test item in Japan: Toward the validation of mathematical models. ONR-Tokyo, Scientific Monograph 3, April, 1980.
- (16) Samejima, F. and R. L. Trestman. Analysis of Iowa Data I: Initial study and findings. RR-80-1, 1980.
- (17) Samejima, F. Estimation of the operating characteristics when the test information of the Old Test is not constant I: Rationale. RR-80-2, 1980.
- (18) Samejima, F. Is Bayesian estimation proper for estimating the individual's ability? RR-80-3, 1980.
- (19) Samejima, F. Estimation of the operating characteristics when the test information of the Old Test is not constant II: Simple Sum Procedure of the Conditional P.D.F. Approach/Normal Approach Method using three subtests of the Old Test. RR-80-4, 1980.
- (20) Samejima, F. An alternative estimator for the maximum likelihood estimator for the two extreme response patterns. RR-81-1, 1981.
- (21) Samejima, F. Estimation of the operating characteristics when the test information of the Old Test is not constant II: Simple Sum Procedure of the Conditional P.D.F. Approach/Normal Approach Method using three subtests of the Old Test. No. 2. RR-81-2, 1981.
- (22) Samejima, F. and P. S. Changas. How small the number of test items can be for the basis of estimating the operating characteristics of the discrete responses to unknown test items. RR-81-3, 1981.
- (23) Samejima, F. Final Report: Efficient methods of estimating the operating characteristics of item response categories and challenge to a new model for the multiple-choice item. Final Report, 1981.

N0014-81-C-0569

- (24) Samejima, F. Information loss caused by noise in models for dichotomous items. ONR/RR-82-1, 1982.
- (25) Samejima, F. Effect of noise in the three-parameter logistic model. ONR/RR-82-2, 1982.

APPENDIX

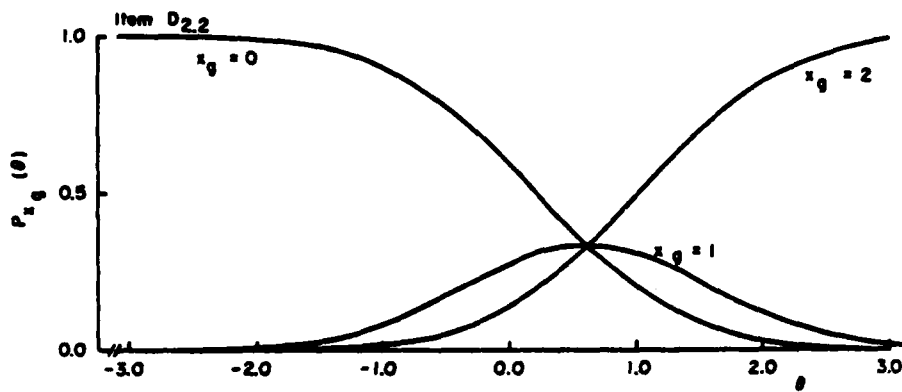

FIGURE 5-1  
Operating characteristics of graded responses for items C<sub>1</sub> and D<sub>1.2</sub> of LIS measurement scale for Non-verbal Reasoning Ability on the normal ogive model.

DISTRIBUTION LIST

<p>Navy</p> <p>1 Dr. Ed Aiken Navy Personnel R&amp;D Center San Diego, CA 92152</p> <p>1 CDR Robert J. Biersner Naval Medical R&amp;D Command National Naval Medical Center Bethesda, MD 20814</p> <p>1 Lisison Scientist Office of Naval Research Branch Office, London Box 39 FPO New York, NY 09510</p> <p>1 Lt. Alexander Bory Applied Psychology Measurement Division NAMRL NAS Pensacola, FL 32508</p> <p>1 Dr. Robert Carroll NAVOP 115 Washington, DC 20370</p> <p>1 Dr. Stanley Collyer Office of Naval Technology 800 N. Quincy Street Arlington, VA 22217</p> <p>1 DR. PAT FEDERICO Code P13 NPRDC San Diego, CA 92152</p> <p>1 Dr. John Ford Navy Personnel R&amp;D Center San Diego, CA 92152</p> <p>1 Dr. Norman J. Kerr Chief of Naval Technical Training Naval Air Station Memphis (75) Millington, TN 38054.</p> <p>1 Dr. William L. Maloy (02) Chief of Naval Education and Training Naval Air Station Pensacola, FL 32508</p> <p>1 Dr. Kacale Marshall Chairman, Operations Research Dept. Naval Post Graduate School Monterey, CA 93940</p>	<p>Navy</p> <p>1 Dr. James McBride Navy Personnel R&amp;D Center San Diego, CA 92152</p> <p>1 Dr William Montague NPRDC Code 13 San Diego, CA 92152</p> <p>1 Bill Wordbrock 1032 Fairlawn Ave. Libertyville, IL 60048</p> <p>1 Library, Code F201L Navy Personnel R&amp;D Center San Diego, CA 92152</p> <p>1 Technical Director Navy Personnel R&amp;D Center San Diego, CA 92152</p> <p>6 Commanding Officer Naval Research Laboratory Code 2627 Washington, DC 20390</p> <p>6 Personnel &amp; Training Research Group Code 442PT Office of Naval Research Arlington, VA 22217</p> <p>1 Lt Frank C. Petho, MSC, USN (Ph.D) CNET (N-432) NAS Pensacola, FL 32508</p> <p>1 Dr. Bernard Rimland (OIC) Navy Personnel R&amp;D Center San Diego, CA 92152</p> <p>1 Dr. Carl Ross CNET-PDCD Building 90 Great Lakes NTC, IL 60088</p> <p>1 Dr. Worth Scanland CNET (M-5) NAS, Pensacola, FL 32508</p> <p>1 Dr. Robert G. Smith Office of Chief of Naval Operations OP-987H Washington, DC 20350</p>	<p>Navy</p> <p>1 Dr. Richard Sorensen Navy Personnel R&amp;D Center San Diego, CA 92152</p> <p>1 Dr. Frederick Steinheiser CWO - OP115 Navy Annex Arlington, VA 20370</p> <p>1 Mr. Brad Sympson Navy Personnel R&amp;D Center San Diego, CA 92152</p> <p>1 Dr. Ronald Weitzman Code 54 WZ Department of Administrative Sciences U. S. Naval Postgraduate School Monterey, CA 93940</p> <p>1 Dr. Douglas Wetzel Code 12 Navy Personnel R&amp;D Center San Diego, CA 92152</p> <p>1 DR. MARTIN F. WISKOFF NAVY PERSONNEL R&amp;D CENTER SAN DIEGO, CA 92152</p> <p>1 Mr John H. Wolfe Navy Personnel R&amp;D Center San Diego, CA 92152</p>
---	---	---

Marine Corps

- 1 H. William Greenup  
Education Advisor (E031)  
Education Center, MCDEC  
Quantico, VA 22134
- 1 Director, Office of Manpower Utilization  
HQ, Marine Corps (MPU)  
BCB, Bldg. 2009  
Quantico, VA 22134
- 1 Headquarters, U. S. Marine Corps  
Code MPI-20  
Washington, DC 20380
- 1 Special Assistant for Marine  
Corps Matters  
Code 100M  
Office of Naval Research  
800 N. Quincy St.  
Arlington, VA 22217
- 1 DR. A.L. SLAFKOSKY  
SCIENTIFIC ADVISOR (CODE RD-1)  
HQ, U.S. MARINE CORPS  
WASHINGTON, DC 20380
- 1 Major Frank Yohannan, USMC  
Headquarters, Marine Corps  
(Code MPI-20)  
Washington, DC 20380

Army

- 1 Technical Director  
U. S. Army Research Institute for the  
Behavioral and Social Sciences  
5001 Eisenhower Avenue  
Alexandria, VA 22333
- 1 Dr. Kent Eaton  
Army Research Institute  
5001 Eisenhower Blvd.  
Alexandria, VA 22333
- 1 Dr. Myron Fischl  
U.S. Army Research Institute for the  
Social and Behavioral Sciences  
5001 Eisenhower Avenue  
Alexandria, VA 22333
- 1 Dr. Milton S. Katz  
Training Technical Area  
U.S. Army Research Institute  
5001 Eisenhower Avenue  
Alexandria, VA 22333
- 1 Mr. Robert Ross  
U.S. Army Research Institute for the  
Social and Behavioral Sciences  
5001 Eisenhower Avenue  
Alexandria, VA 22333
- 1 Dr. Hilda Wing  
Army Research Institute  
5001 Eisenhower Ave.  
Alexandria, VA 22333
- 1 Dr. Robert Wisner  
Army Research Institute  
5001 Eisenhower Avenue  
Alexandria, VA 22333

Air Force

- 1 Technical Documents Center  
Air Force Human Resources Laboratory  
WPAFB, OH 45433
- 1 U.S. Air Force Office of Scientific  
Research  
Life Sciences Directorate, NL  
Bolling Air Force Base  
Washington, DC 20332
- 1 Air University Library  
AUL/LSE 76/443  
Maxwell AFB, AL 36112
- 1 Dr. Earl A. Alluisi  
HQ, AFHRL (AFSC)  
Brooks AFB, TX 78235
- 1 Mr. Raymond E. Christal  
AFHRL/MOE  
Brooks AFB, TX 78235
- 1 Dr. Alfred R. Fregly  
AFOSR/NL  
Bolling AFB, DC 20332
- 1 Dr. Roger Pennell  
Air Force Human Resources Laboratory  
Lowry AFB, CO 80230
- 1 Dr. Malcolm Ree  
AFHRL/MP  
Brooks AFB, TX 78235

Department of Defense

12 Defense Technical Information Center  
Cameron Station, Bldg 5  
Alexandria, VA 22314  
Attn: TC

1 Jerry Lehnus  
HQ NEPCOM  
Attn: HEFCT-P  
Fort Sheridan, IL 60037

1 Military Assistant for Training and  
Personnel Technology  
Office of the Under Secretary of Defense  
for Research & Engineering  
Room 3D129, The Pentagon  
Washington, DC 20301

1 Dr. Wayne Sellman  
Office of the Assistant Secretary  
of Defense (MRA & L)  
28269 The Pentagon  
Washington, DC 20301

1 Major Jack Thorpe  
DARPA  
1400 Wilson Blvd.  
Arlington, VA 22209

Civilian Agencies

1 Dr. Susan Chipman  
Learning and Development  
National Institute of Education  
1200 19th Street NW  
Washington, DC 20208

1 Dr. Vern W. Urry  
Personnel R&D Center  
Office of Personnel Management  
1900 E Street NW  
Washington, DC 20415

1 Mr. Thomas A. Warr  
U. S. Coast Guard Institute  
P. O. Substation 18  
Oklahoma City, OK 73169

1 Dr. Frank Withrow  
U. S. Office of Education  
400 Maryland Ave. SW  
Washington, DC 20202

1 Dr. Joseph L. Young, Director  
Memory & Cognitive Processes  
National Science Foundation  
Washington, DC 20550

Private Sector

1 Dr. James Algina  
University of Florida  
Gainesville, FL 326

1 Dr. Erling B. Andersen  
Department of Statistics  
Studiestraede 6  
1455 Copenhagen  
DENMARK

1 Psychological Research Unit  
Dept. of Defense (Army Office)  
Campbell Park Offices  
Canberra ACT 2600  
AUSTRALIA

1 Dr. Alan Baddeley  
Medical Research Council  
Applied Psychology Unit  
15 Chaucer Road  
Cambridge CB2 2EP  
ENGLAND

1 Dr. Isaac Bejar  
Educational Testing Service  
Princeton, NJ 08450

1 Dr. Menucha Birenbaum  
School of Education  
Tel Aviv University  
Tel Aviv, Ramat Aviv 69978  
Israel

1 Dr. R. Darrel Bock  
Department of Education  
University of Chicago  
Chicago, IL 60637

1 Dr. Robert Brennan  
American College Testing Programs  
P. O. Box 168  
Iowa City, IA 52243

1 Bundesministerium der Verteidigung  
-Referat P II 4-  
Psychological Service  
Postfach 1328  
D-5300 Bonn 1  
F. R. of Germany

1 Dr. Ernest R. Cadotte  
307 Stokely  
University of Tennessee  
Knoxville, TN 37916

Private Sector

1 Dr. Pat Carpenter  
Department of Psychology  
Carnegie-Mellon University  
Pittsburgh, PA 15213

1 Dr. John B. Carroll  
409 Elliott Rd.  
Chapel Hill, NC 27514

1 Dr. Norman Cliff  
Dept. of Psychology  
Univ. of So. California  
University Park  
Los Angeles, CA 90007

1 Dr. Allan M. Collins  
Bolt Beranek & Newman, Inc.  
50 Moulton Street  
Cambridge, MA 02138

1 Dr. Lynn A. Cooper  
LRDC  
University of Pittsburgh  
3939 O'Hara Street  
Pittsburgh, PA 15213

1 Dr. Fritz Dragow  
Department of Psychology  
University of Illinois  
603 E. Daniel St.  
Champaign, IL 61820

1 Dr. Susan Embertson  
PSYCHOLOGY DEPARTMENT  
UNIVERSITY OF KANSAS  
Lawrence, KS 66045

1 ERIC Facility-Acquisitions  
4833 Rugby Avenue  
Bethesda, MD 20014

1 Dr. Benjamin A. Fairbank, Jr.  
McFann-Gray & Associates, Inc.  
5825 Callaghan  
Suite 225  
San Antonio, TX 78228

1 Dr. Leonard Feldt  
Lindquist Center for Measurement  
University of Iowa  
Iowa City, IA 52242

Private Sector

1 Dr. Richard L. Ferguson  
The American College Testing Program  
P.O. Box 168  
Iowa City, IA 52240

1 Univ. Prof. Dr. Gerhard Fischer  
Liebiggasse 5/3  
A 1010 Vienna  
AUSTRIA

1 Professor Donald Fitzgerald  
University of New England  
Armidale, New South Wales 2351  
AUSTRALIA

1 Dr. Dexter Fletcher  
WICAT Research Institute  
1875 S. State St.  
Orem, UT 22333

1 Dr. John R. Frederiksen  
Bolt Beranek & Newman  
50 Moulton Street  
Cambridge, MA 02138

1 Dr. Janice Gifford  
University of Massachusetts  
School of Education  
Amherst, MA 01002

1 Dr. Robert Glaser  
Learning Research & Development Center  
University of Pittsburgh  
3939 O'Hara Street  
PITTSBURGH, PA 15260

1 Dr. Bert Green  
Johns Hopkins University  
Department of Psychology  
Charles & 34th Street  
Baltimore, MD 21218

1 Dr. Ron Hambleton  
School of Education  
University of Massachusetts  
Amherst, MA 01002

1 Dr. Lloyd Humphreys  
Department of Psychology  
University of Illinois  
Champaign, IL 61820

Private Sector

1 Dr. Steven Hunka  
Department of Education  
University of Alberta  
Edmonton, Alberta  
CANADA

1 Dr. Earl Hunt  
Dept. of Psychology  
University of Washington  
Seattle, WA 98105

1 Dr. Huynh Huynh  
College of Education  
University of South Carolina  
Columbia, SC 29208

1 Dr. Douglas H. Jones  
Room T-255/21-T  
Educational Testing Service  
Princeton, NJ 08541

1 Professor John A. Keats  
University of Newcastle  
N. S. W. 2308  
AUSTRALIA

1 Mr. Jeff Keley  
Department of Instructional Technology  
University of Southern California  
Los Angeles, CA 92007

1 Dr. Scott Kelso  
Haskins Laboratories, Inc  
270 Crown Street  
New Haven, CT 06510

1 Dr. Stephen Kosslyn  
Department of Psychology  
The Johns Hopkins University  
Baltimore, MD 21218

1 Dr. Alan Lesgold  
Learning R&D Center  
University of Pittsburgh  
3939 O'Hara Street  
Pittsburgh, PA 15260

1 Dr. Michael Levine  
Department of Educational Psychology  
210 Education Bldg.  
University of Illinois  
Champaign, IL 61801

Private Sector

1 Dr. Charles Lewis  
Faculteit Sociale Wetenschappen  
Rijksuniversiteit Groningen  
Oude Boteringestraat 23  
9712GC Groningen  
Netherlands

1 Dr. Robert Linn  
College of Education  
University of Illinois  
Urbana, IL 61801

1 Mr. Phillip Livingston  
Systems and Applied Sciences Corporatio  
6811 Kanilworth Avenue  
Riverdale, MD 20840

1 Dr. Robert Lockman  
Center for Naval Analysis  
200 North Beaugard St.  
Alexandria, VA 22311

1 Dr. Frederic M. Lord  
Educational Testing Service  
Princeton, NJ 08541

1 Dr. James Lumsden  
Department of Psychology  
University of Western Australia  
Nedlands W.A. 6009  
AUSTRALIA

1 Dr. Gary Marco  
Stop 31-E  
Educational Testing Service  
Princeton, NJ 08451

1 Dr. Scott Maxwell  
Department of Psychology  
University of Notre Dame  
Notre Dame, IN 46556

1 Dr. Samuel T. Mayo  
Loyola University of Chicago  
820 North Michigan Avenue  
Chicago, IL 60611

1 Mr. Robert McKinley  
American College Testing Programs  
P.O. Box 168  
Iowa City, IA 52243

Private Sector

1 Professor Jason Millman  
Department of Education  
Stone Hall  
Cornell University  
Ithaca, NY 14853

1 Dr. Allen Munro  
Behavioral Technology Laboratories  
1845 Elena Ave., Fourth Floor  
Redondo Beach, CA 90277

1 Dr. W. Alan Micevander  
University of Oklahoma  
Department of Psychology  
Oklahoma City, OK 73069

1 Dr. Donald A. Norman  
Cognitive Science, C-015  
Univ. of California, San Diego  
La Jolla, CA 92093

1 Dr. Melvin R. Novick  
356 Lindquist Center for Measurement  
University of Iowa  
Iowa City, IA 52242

1 Dr. James Olson  
WICAF, Inc.  
1875 South State Street  
Orem, UT 84057

1 Dr. Jesse Oriansky  
Institute for Defense Analyses  
1801 N. Beaugard St.  
Alexandria, VA 22311

1 Wayne M. Patience  
American Council on Education  
GED Testing Service, Suite 20  
One Dupont Circle, NW  
Washington, DC 20036

1 Dr. James A. Paulson  
Portland State University  
P.O. Box 751  
Portland, OR 97207

1 Dr. James W. Pellegrino  
University of California,  
Santa Barbara  
Dept. of Psychology  
Santa Barbara, CA 93106

Private Sector

1 Dr. Mark D. Reckase  
ACT  
P. O. Box 168  
Iowa City, IA 52243

1 Dr. Thomas Reynolds  
University of Texas-Dallas  
Marketing Department  
P. O. Box 688  
Richardson, TX 75080

1 Dr. Andrew M. Rose  
American Institutes for Research  
1055 Thomas Jefferson St. NW  
Washington, DC 20007

1 Dr. Ernst Z. Rothkopf  
Bell Laboratories  
Murray Hill, NJ 07974

1 Dr. David Rumelhart  
Center for Human Information Processing  
Univ. of California, San Diego  
La Jolla, CA 92093

1 Dr. J. Ryan  
Department of Education  
University of South Carolina  
Columbia, SC 29208

1 PROF. FUMIKO SAMEJIMA  
DEPT. OF PSYCHOLOGY  
UNIVERSITY OF TENNESSEE  
KNOXVILLE, TN 37916

1 Dr. Walter Schneider  
Psychology Department  
603 E. Daniel  
Champaign, IL 61820

1 Lowell Schoer  
Psychological & Quantitative  
Foundations  
College of Education  
University of Iowa  
Iowa City, IA 52242

1 Dr. Kazuo Shigemasa  
University of Tohoku  
Department of Educational Psychology  
Kawauchi, Sendai 980  
JAPAN

Private Sector

1 Dr. Edwin Shirkey  
Department of Psychology  
University of Central Florida  
Orlando, FL 32816

1 Dr. William Sims  
Center for Naval Analysis  
200 North Beauregard Street  
Alexandria, VA 22311

1 Dr. Richard Snow  
School of Education  
Stanford University  
Stanford, CA 94305

1 Dr. Elliott Soloway  
Yale University  
Department of Computer Science  
P.O. Box 2158  
New Haven, CT 06520

1 Dr. Robert Sternberg  
Dept. of Psychology  
Yale University  
Box 11A, Yale Station  
New Haven, CT 06520

1 Dr. Peter Stoloff  
Center for Naval Analysis  
200 North Beauregard Street  
Alexandria, VA 22311

1 David E. Stone, Ph.D.  
Hazeltine Corporation  
7680 Old Springhouse Road  
McLean, VA 22102

1 Dr. William Stout  
University of Illinois  
Department of Mathematics  
Urbana, IL 61801

1 DR. PATRICK SUPPES  
INSTITUTE FOR MATHEMATICAL STUDIES IN  
THE SOCIAL SCIENCES  
STANFORD UNIVERSITY  
STANFORD, CA 94305

1 Dr. Hariharan Swaminathan  
Laboratory of Psychometric and  
Evaluation Research  
School of Education  
University of Massachusetts  
Amherst, MA 01003

Private Sector

1 Dr. Kikumi Tatsuoka  
Computer Based Education Research Lab  
252 Engineering Research Laboratory  
Urbana, IL 61801

1 Dr. Maurice Tatsuoka  
220 Education Bldg  
1310 S. Sixth St.  
Champaign, IL 61820

1 Dr. David Thissen  
Department of Psychology  
University of Kansas  
Lawrence, KS 66044

1 Dr. Douglas Towne  
Univ. of So. California  
Behavioral Technology Labs  
1845 S. Elena Ave.  
Redondo Beach, CA 90277

1 Dr. Robert Tsutakawa  
Department of Statistics  
University of Missouri  
Columbia, MO 65201

1 Dr. V. R. R. Uppuluri  
Union Carbide Corporation  
Nuclear Division  
P. O. Box Y  
Oak Ridge, TN 37830

1 Dr. David Vale  
Assessment Systems Corporation  
2233 University Avenue  
Suite 310  
St. Paul, MN 55114

1 Dr. Kurt Van Lehn  
Zerex PARC  
3333 Coyote Hill Road  
Palo Alto, CA 94304

1 Dr. Howard Wainer  
Division of Psychological Studies  
Educational Testing Service  
Princeton, NJ 08540

1 Dr. Brian Waters  
HumERO  
300 North Washington  
Alexandria, VA 22314

Private Sector

1 Dr. David J. Weiss  
M660 Elliott Hall  
University of Minnesota  
75 E. River Road  
Minneapolis, MN 55455

1 Dr. Christopher Wickens  
Department of Psychology  
University of Illinois  
Champaign, IL 61820

1 Dr. Rand R. Wilcox  
University of Southern California  
Department of Psychology  
Los Angeles, CA 90007

1 Wolfgang Wildgrube  
Streitkræfteamt  
Box 20 50 03  
D-5300 Bonn 2  
WEST GERMANY

1 Dr. Bruce Williams  
Department of Educational Psychology  
University of Illinois  
Urbana, IL 61801

1 Dr. Wendy Yen  
CTB/McGraw Hill  
Del Monte Research Park  
Monterey, CA 93940

Navy

- 1 Ms. Nancy McHam  
Office of Naval Research  
206 O'Keefe Building  
Atlanta, GA 30332

Army

- 1 Dr. Randall M. Chambers  
U.S. Army Research Institute for  
the Behavioral & Social Sciences  
Fort Sill Field Unit  
P.O. Box 3066  
Fort Sill, OK 73503

Non Govt

- 1 Dr. Robert Guion  
Department of Psychology  
Bowling Green State University  
Bowling Green, OH 43403
- 1 Dr. Niel Tims  
Department of Information Systems  
Planning  
University of Pittsburgh  
Pittsburgh, PA 15260

- 1 Dr. William W. Turnbull  
Educational Testing Service  
Princeton, NJ 08542

- 1 Dr. P. Mengal  
Faculte' de Psychologie  
et des Sciences de l'Education  
Universite' de Geneve  
3 fl. de l'Universite  
1201 Geneva SWITZERLAND

- 1 Dr. Wim J. van der Linden  
Vakgroep Onderwijskunde  
Postbus 217  
7500 EA Enschede  
THE NETHERLANDS

- 1 Dr. Lutz Hornke  
University Dueseldorf  
Erz. Wiss.  
D-4000 Dueseldorf  
WEST GERMANY

- 1 Dr. Wolfgang Buchta  
8346 Simbach Inn  
Postfach 1306  
Industriestrasse 1  
WEST GERMANY

- 1 Dr. Albert Beaton  
Educational Testing Service  
Princeton, NJ 08542

- 1 Dr. Sukeyori Shiba  
Faculty of Education  
University of Tokyo  
Hongo, Bunkyo-ku  
Tokyo, JAPAN 113

Non Govt

- 1 Dr. Yukihiko Noguchi  
1208-7 Kamoi, Midoriku  
Yokohama 216, JAPAN

- 1 Dr. Takahiro Sato  
Nippon Electric Co., Ltd.  
C & C Systems Research Laboratories  
4-1-1 Miyazaki  
Miyamaeku, Kawasaki  
Kanagawaken 213, JAPAN

- 1 Dr. James Chen  
354 Lindquist Center for Measurement  
University of Iowa  
Iowa City, Iowa 52240

- 1 Dr. Douglas Carroll  
Bell Laboratories  
600 Mountain Ave.  
Murray Hill, N.J. 07974

- 1 Dr. Lovell Schipper  
Department of Psychology  
Bowling Green State University  
Bowling Green, OH 43403

- 1 Dr. J. Uhlaner  
Perceptronics, Inc.  
6271 Varial Avenue  
Woodland Hills, CA 91634

**END**

**FILMED**

**9-83**

**DTIC**