

MICROCOPY RESOLUTION TEST CHART
NATIONAL BUREAU OF STANDARDS-1963-A

OI 630.0 nm Optical Measurements of Neutral Winds, Temperatures
and Airglow Enhancements during the BIME Program

Manfred A. Biondi, Principal Investigator

Dept. of Physics and Astronomy, University of Pittsburgh

AUG 24 1983

I. Introduction

The objectives of these passive optical measurements have been:

(1) to determine the F-region neutral wind vectors and temperatures from doppler shift and doppler width measurements of the OI 630.0 nm twilight and nightglow emissions, and (2) to map 630.0 nm airglow enhancements produced by the BIME chemical releases. The normal F-region airglow arises from the pair of reactions

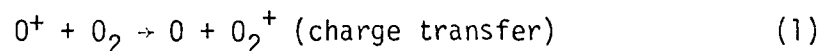

and

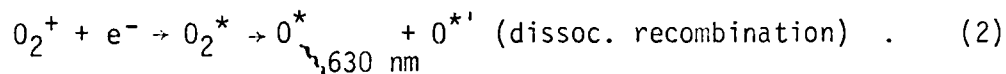

In the case of the BIME releases of large amounts of H₂O and CO₂, the artificially produced airglow results from the prompt reaction

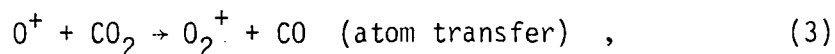

followed by reaction (2) to produce 630.0 nm radiation.

Two distinct instruments have been used to achieve these objectives, a very high resolution, sensitive Fabry-Perot interferometer for doppler shift and width determinations and a sky-mapping filter photometer for airglow enhancement observations. The instruments worked well, but unfavorable cloud conditions much of the time over our coastal observation site (Baker-Nunn Building at CLFBI) limited the amount of useful data obtained. If there are future experiments at CLFBI, the optical instruments should be located some 10 km or more inland, where the fast-moving, puffy coastal clouds

Approved for public release;
distribution unlimited.

REPORT DOCUMENTATION PAGE		READ INSTRUCTIONS BEFORE COMPLETING FORM
1. REPORT NUMBER AFOSR-TR- 83-0711	2. GOVT ACCESSION NO.	3. RECIPIENT'S CATALOG NUMBER
4. TITLE (and Subtitle) OI 630.0 nm Optical Measurements of Neutral Winds, Temperatures and Airglow Enhancements during the BIME Program		5. TYPE OF REPORT & PERIOD COVERED Final 12/1/81 - 5/31/83
7. AUTHOR(s) Manfred A. Biondi		6. PERFORMING ORG. REPORT NUMBER
9. PERFORMING ORGANIZATION NAME AND ADDRESS Department of Physics & Astronomy University of Pittsburgh Pittsburgh, PA 15260		8. CONTRACT OR GRANT NUMBER(s) AFOSR-82-0055
11. CONTROLLING OFFICE NAME AND ADDRESS AFOSR/NC Bolling AFB DC 20332		10. PROGRAM ELEMENT PROJECT, TASK AREA & WORK UNIT NUMBERS 2310/A2 61102F
14. MONITORING AGENCY NAME & ADDRESS (if different from Controlling Office)		12. REPORT DATE 7-25-83
		13. NUMBER OF PAGES 8
		15. SECURITY CLASS. (of this report) Unclassified
		15a. DECLASSIFICATION DOWNGRADING SCHEDULE
16. DISTRIBUTION STATEMENT (of this Report) Approved for public release; distribution unlimited.		
17. DISTRIBUTION STATEMENT (of the abstract entered in Block 20, if different from Report)		
18. SUPPLEMENTARY NOTES		
19. KEY WORDS (Continue on reverse side if necessary and identify by block number) 630.0 nm airglow, airglow enhancement, interferometry, sky-mapping photometry, thermospheric dynamics, thermospheric motion, thermospheric temperature		
20. ABSTRACT (Continue on reverse side if necessary and identify by block number) A 100 mm aperture, field-widened Fabry-Perot interferometer was used in support of the B.I.M.E. F-region chemical release program to measure 630.0 nm night-glow line profiles and from this to determine the pattern of F-region thermospheric dynamics (neutral velocity vector \vec{v}_n and neutral temperature T_n versus time) from 24 August 1982 to 19 September 1982 at Natal Brazil. A 3-channel, sky-mapping filter photometer measured the temporal and spatial evolution of the 630.0 nm airglow enhancement produced by the first B.I.M.E. release (8 Sept. 1982). Clouds over our observing site obscured the second B.I.M.E. release (13 Sept. 1982).		

(formed by the lifting of the night-time onshore breeze over the sand dunes) have a chance to dissipate.

II. Optical Instruments

The field-widened 100 mm aperture Fabry-Perot interferometer¹ shown schematically in Fig. 1 is pressure scanned across the OI 630.0 nm spectral line, with a high-red-sensitivity photomultiplier detector (RCA 31034A) operated in a pulse-counting mode. The line-of-sight of the instrument (and that of the companion tilting filter photometer which monitors background and interfering radiation) is directed to appropriate points in the sky by the stepping-motor-driven pointing head. Instrumental resolving power determinations and the zero-velocity reference position are provided by the stabilized He-Ne laser (632.8 nm). Instrument control and real-time data processing are provided by a microprocessor and Apple II microcomputer.

The three-channel, sky-mapping filter photometer² is shown schematically in Fig. 2. The filters used are typically 0.3 nm wide, centered at 630.0 nm, 631.0 nm, and 557.7 nm. Flexible scanning patterns are provided by two stepping motors programmed to produce controlled rotations about two orthogonal axes. Real-time presentation of the sky-maps is provided by an Apple II microcomputer and a color video monitor.

III. Neutral Wind and Temperature Data

The results reported are based on analysis of the 630.0 nm line profiles to obtain the required doppler shifts and doppler widths. The magnetic tape data records have been analyzed using the University of Pittsburgh's computer to fit the line profiles accurately, thus providing values of both \bar{v}_n (doppler shifts) and T_n (widths). Useful data were obtained on 21 nights, some fragmentary, some covering extensive periods of time during the night.

To characterize the evening wind patterns near the planned times of the BIME releases (early post-twilight), we have collected all of our



Form with fields for 'Codes', 'and/or', 'Special', and a handwritten '41' at the bottom.

measurements at ~ 2130 UT (1830 LT) and present them in Table I. Most of the measured F-region wind vectors at that time of evening are between 90 and 130 m/s in magnitude and are directed ESE at azimuths of $\sim 110^\circ \pm 15^\circ$.

The measured wind on 08 Sept. 1982 (the first BIME release) was 135 m/s eastward (zonal) at 2125 UT. This was one of the highest early evening wind velocities observed. At the time of the second BIME release on 13 Sept. 1982, extensive cloud cover limited our observations to the westward azimuth, where a rapidly decreasing zonal component was observed.

The rapid post-twilight decrease in 630.0 nm airglow intensity to very small values (due to the rapid increase in the height of the F_2 bottomside) often caused us to suspend our observations until the later-night sinking of the ionosphere restored the airglow intensity to a usable value. (Unfortunately, later-night cloud cover was a common occurrence at Baker-Nunn).

Examples of some extended observations on three nights are given in Figs. 3 to 11. The symbols on the meridional and zonal wind graphs indicate the observing azimuth (measurements were made, in general, at 30° elevation).

In the data of 26 Aug. 1982, Figs. 3-5, a very interesting correlation between horizontal flow in the neutral thermosphere and vertical motion has been observed for the first time. The meridional flow (Fig. 3) shows substantial convergence (slight southward flow north of Natal, stronger northward flow to the south), while the zonal flow (Fig. 4) shows no significant convergence or divergence. Thus, there is a net convergence in the horizontal flow until ~ 2330 UT. The vertical motions indicate a downward flow of about 20 m/s (negative values in Fig. 5) during much of this period, with a return to upward flow after ~ 2300 UT. These inferences concerning vertical motions are at the limit of our accuracy, ~ 10 m/s; further, there

is no absolute zero velocity reference, since our stable reference, the He-Ne laser line, is at a slightly different wavelength, 628.8 nm, compared to our OI airglow line, 630.0 nm. The vertical motions are plotted so that their average value during the course of the measurements is zero.

By contrast, the data of 6 Sept. 1982 (Figs. 6-8) show no systematic convergence/divergence in either the meridional or the zonal flow, and the corresponding vertical motion drifts from ~ 5 m/s downward at the beginning of the observations to ~ 5 m/s upward at the end. The data for 11 Sept. 1982 (Figs. 9-11) show initial meridional convergence, dying away after ~ 1 hour, while the zonal flow converges weakly throughout the observations. The vertical motion in response to this weakly defined pattern suggests a downward initial motion (the lack of an absolute vertical velocity reference limits our conclusions).

The behavior of the neutral thermosphere's temperature T_n during the same three nights is shown in Figs. 12-14. On 26 Aug. 1983 (Fig. 12) the temperatures to the north (and to the west) of Natal became increasingly larger than those to the south, east and overhead; a maximum difference of ~ 500 K is noted at the end of the observations. By contrast, the T_n data for 6 Sept. 1982 (Fig. 13) and for 11 Sept. 1982 (Fig. 14) indicate little difference in T_n values in the various observing directions, with values to the north slightly higher than those to the south (~ 100 - 200 K). While the normal, post-sunset decrease in T_n is found in the 6 Sept. data covering the early night (1800 \rightarrow 2030 LT), the data for 11 Sept. (12 Sept. World Date) indicate a progressive rise in T_n through local midnight (2230 \rightarrow 0100 LT). The rising exospheric temperatures on 26 August and 11 September may correlate with the net convergence in horizontal flow noted in the wind data; these data provide important tests of the prediction capabilities of TGCM's (thermospheric general circulation models).

IV. BIME release Airglow Enhancement

The sky-mapping photometer (Fig. 2) was used to map a 250 km by 300 km area of the F-region centered at the expected release points. While the Baker-Nunn observation site was free of clouds for a significant period during the first BIME release (08 Sept. 1982), almost solid cloud cover obscured the upper atmosphere during the second BIME release (13 Sept. 1982).

The measured 630.0 nm intensity contours associated with the enhanced airglow produced by the first BIME release (at 1845 $\frac{1}{2}$ LT, 08 Sept. 1982) are given in Fig. 15 (the local zenith is indicated by the letter Z). The airglow region expands and grows in brightness for somewhat more than 2 minutes after the release. The drift of the centroid of the enhanced region during the 2 minute interval 1846 $\frac{1}{2}$ -1848 $\frac{1}{2}$ LT corresponds to a velocity of ~ 250 m/s directed at an azimuth of $\sim 120^\circ$. This drift, while in the same general direction, is almost twice as large as the neutral velocity determined from the doppler shift in the natural airglow 630.0 nm emission line measured at ~ 1830 LT on a number of nights (refer to Table I). The release altitude may have been significantly higher, ~ 323 km, than the natural airglow's emission altitude, suggesting the presence of a substantial altitude gradient in the neutral wind velocity. Qualitative supporting evidence for such a hypothesis is provided by observations of rather abrupt increases (within ~ 30 min.) in zonal wind velocity in the immediate post-sunset period, when the emitting layer is rising rapidly (see, for example, Fig. 7).

The absolute intensities (in Rayleighs) on the contours in Fig. 15 are preliminary in nature and were established by means of a low brightness calibrating source applied to the sky-mapper shortly after the end of the release observations. There seems to be a major discrepancy between our intensity values and other photometric measurements such as those from the

AFGL aircraft, with our values very much the smaller. Currently we have no satisfactory resolution of the disagreement.

V. Summary

This report presents results of 630.0 nm airglow measurements by our field-widened Fabry-Perot interferometer from which we have obtained thermospheric neutral velocity vectors (\vec{v}_n) from the doppler shifts and neutral temperatures (T_n) from the doppler broadening of the 630.0 nm lines. These data both help to establish the ionospheric conditions under which natural or induced plasma instabilities do and do not occur and also provide valuable observational information concerning equatorial thermospheric dynamics which may be compared with atmospheric circulation models such as the Thermospheric General Circulation Model (TGCM) of NCAR³. For the first time, direct determinations of the small vertical motions of the neutral thermosphere have been made and correlated with convergence or divergence in the horizontal flow over extended periods (hours). Previously, Hernandez⁴ had measured short-period (~ 40 min.) oscillations in vertical motion which he attributed to the passage of gravity waves.

Details of the growth and drift of the 630.0 nm airglow enhancements produced by the BIME releases are well characterized by the sky-mapping photometer measurements. Future studies of this type require only a better choice of observational site in terms of greater likelihood of clear sky conditions at release time.

Acknowledgement

While this is the Final Report of research supported, in part, by the AFOSR under Grant No. AFOSR-82-0055, our overall airglow observation program at Natal was also supported by the NSF under Grant No. ATM-8121723.

References

1. D. P. Sipler, M. A. Biondi and R. G. Roble, Planet. Space Sci. 31, 53 (1983).
2. D. P. Sipler, M. A. Biondi and R. D. Hake, Jr., Planet. Space Sci. 29, 1267 (1981).
3. See, for example, R. G. Roble, R. E. Dickinson and E. C. Ridley, J. Geophys. Res. 87, 1599 (1982).
4. G. Hernandez, Geophys. Res. Letts. 9, 555 (1982).

Table I. F-Region Neutral Wind Vector at ~ 2130 UT. (UT = LT + 3 hrs.)

<u>Date</u>	<u>World Day</u>	<u>Magnitude (m/s)</u>	<u>Azimuth</u>	<u>Remarks</u>
24 Aug.	236	150 \pm 20	90° \pm 10°	-
26 "	<u>238</u>	125 \pm 20	69° \pm 8°	Equatorward
27 "	239	110 \pm 20	125° \pm 10°	-
28 "	240	60 \pm 20	125° \pm 12°	No stabilized laser
29 "	241	90 \pm 20	125° \pm 10°	" " "
30 "	242	90 \pm 20	125° \pm 10°	" " "
3 Sept.	246	(80 \pm 20)	-	Zonal component only
4 "	247	100 \pm 20	95° \pm 5°	New stab. laser
5 "	248	80 \pm 20	110° \pm 12°	Clouds; W & S only
6 "	<u>249</u>	50 \pm 15	75° \pm 10°	-
7 "	250	130 \pm 20	110° \pm 10°	Velocity decreasing rapidly
8 "	251	(+ 135 \pm 20 Zonal)	-	BIME Release @ 2145 $\frac{1}{2}$
9 "	252	95 \pm 20	100° \pm 10°	-
10 "	253	60 \pm 20	105° \pm 12°	-
11 "	<u>254</u>	85 \pm 20	110° \pm 12°	
12 "	255	(+ 95 \pm 20 Zonal)		Zonal component only
13 "	256	(+ 60 \pm 10 Zonal @ 2110)		BIME Release @ 2108 $\frac{1}{2}$
15 "	258	45 \pm 15	125° \pm 12°	-
17 "	260	-	-	CB @ 2056; Ba lines only
18 "	261	-	-	CB @ 2045; No early evening winds
19 "	262	110 \pm 20	120° \pm 10°	-

Underlined day = more extensive results given in figure in report.

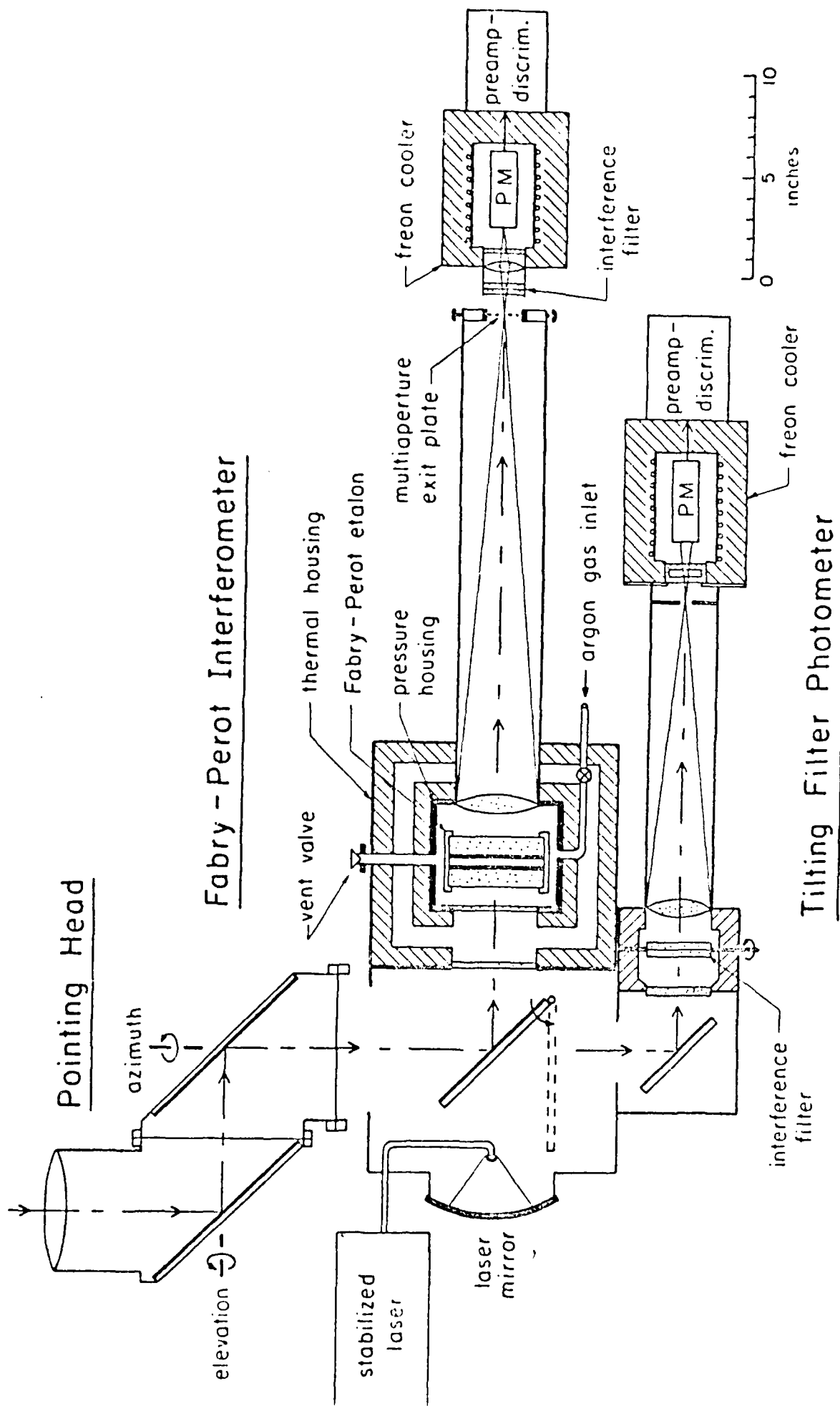

Fig. 1 The 100 mm aperture, field-widened Fabry-Perot interferometer and 74 mm aperture tilting-filter photometer.

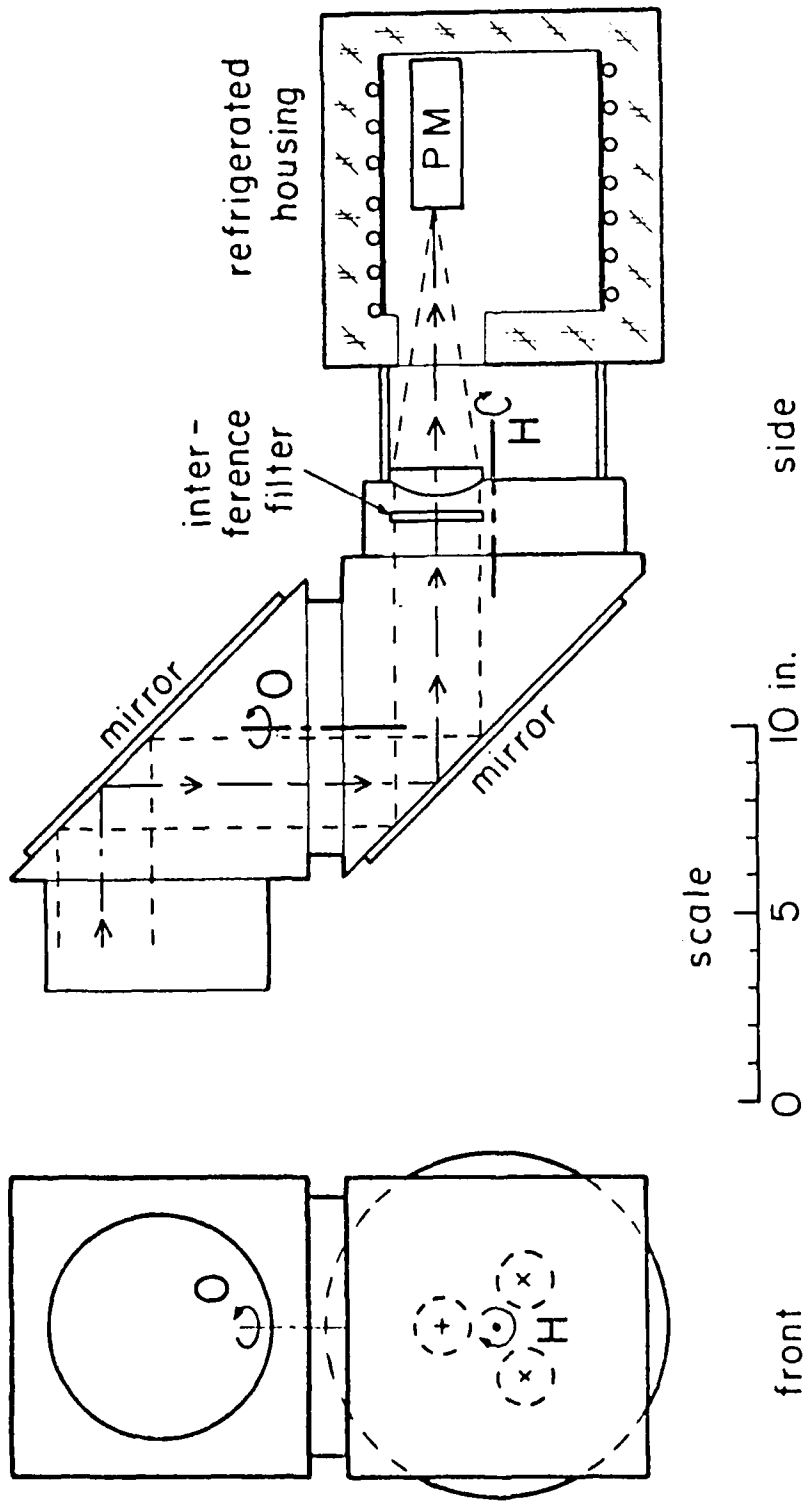

Fig. 2 The 3-channel, sky-mapping filter photometer.

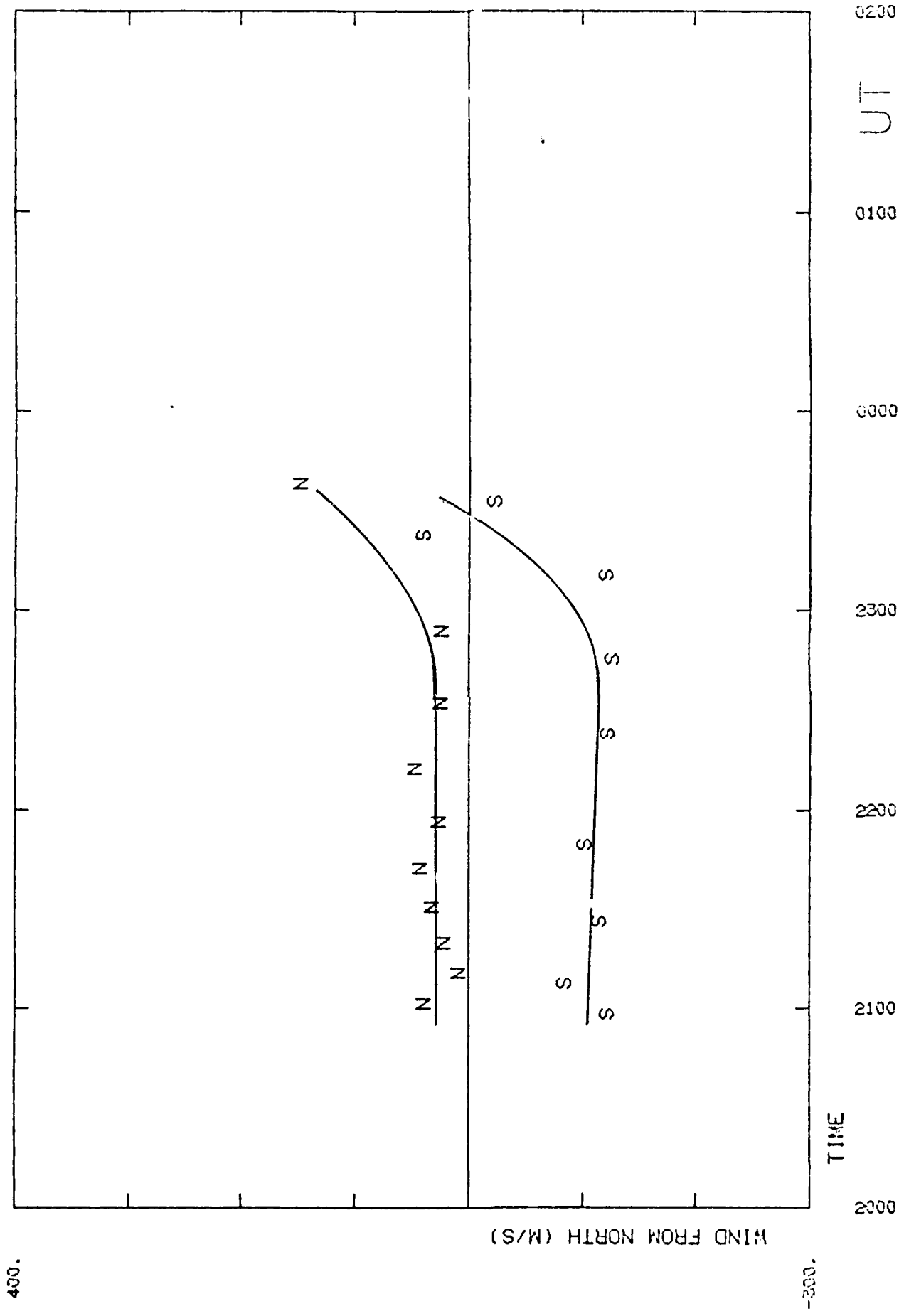

Fig. 3 E-region meridional winds measured at Natal, Brazil on 26 Aug. 1962. (UT = LT + 3 hours)

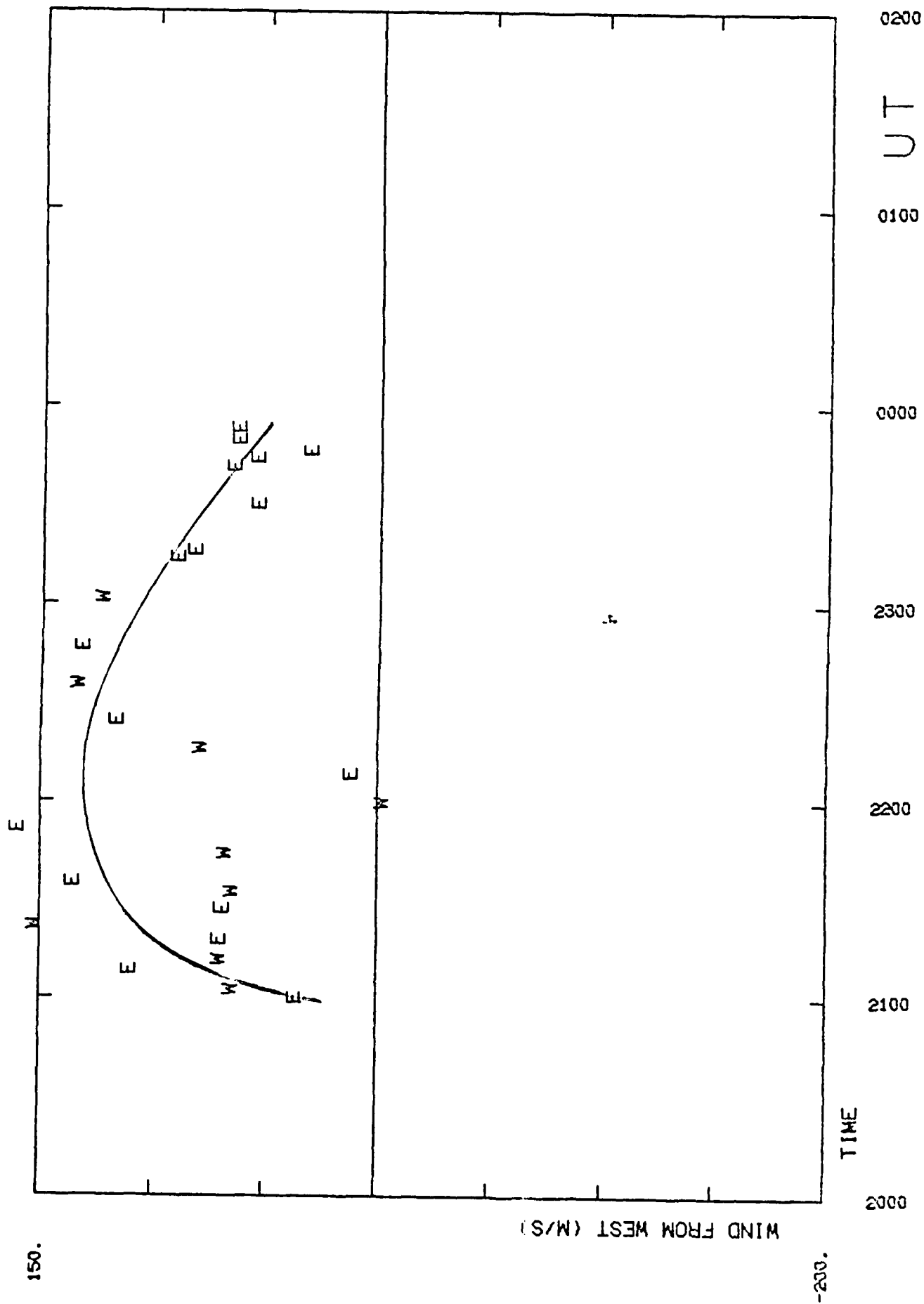

Fig. 4 F-region zonal winds on 26 Aug. 1982

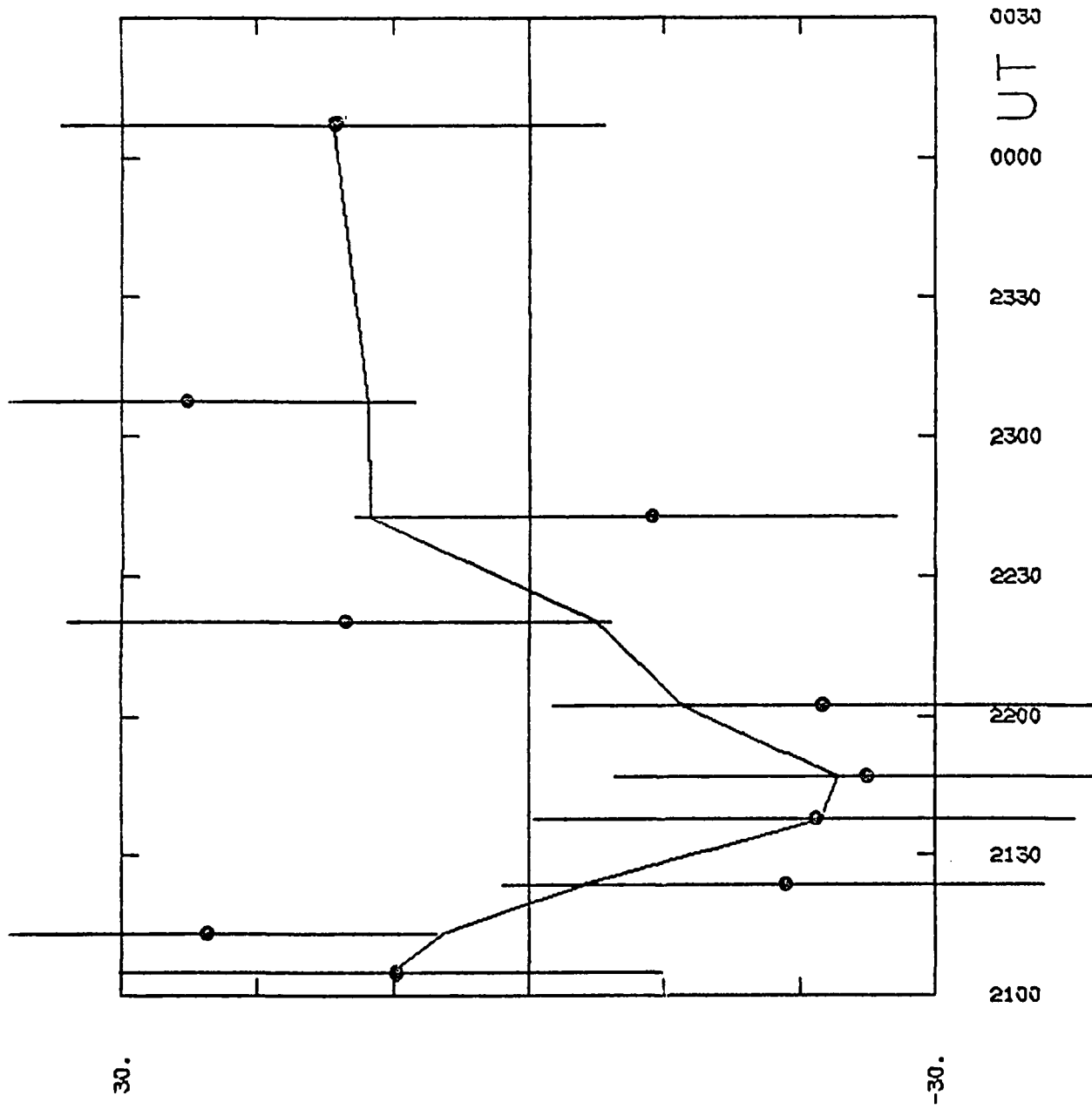
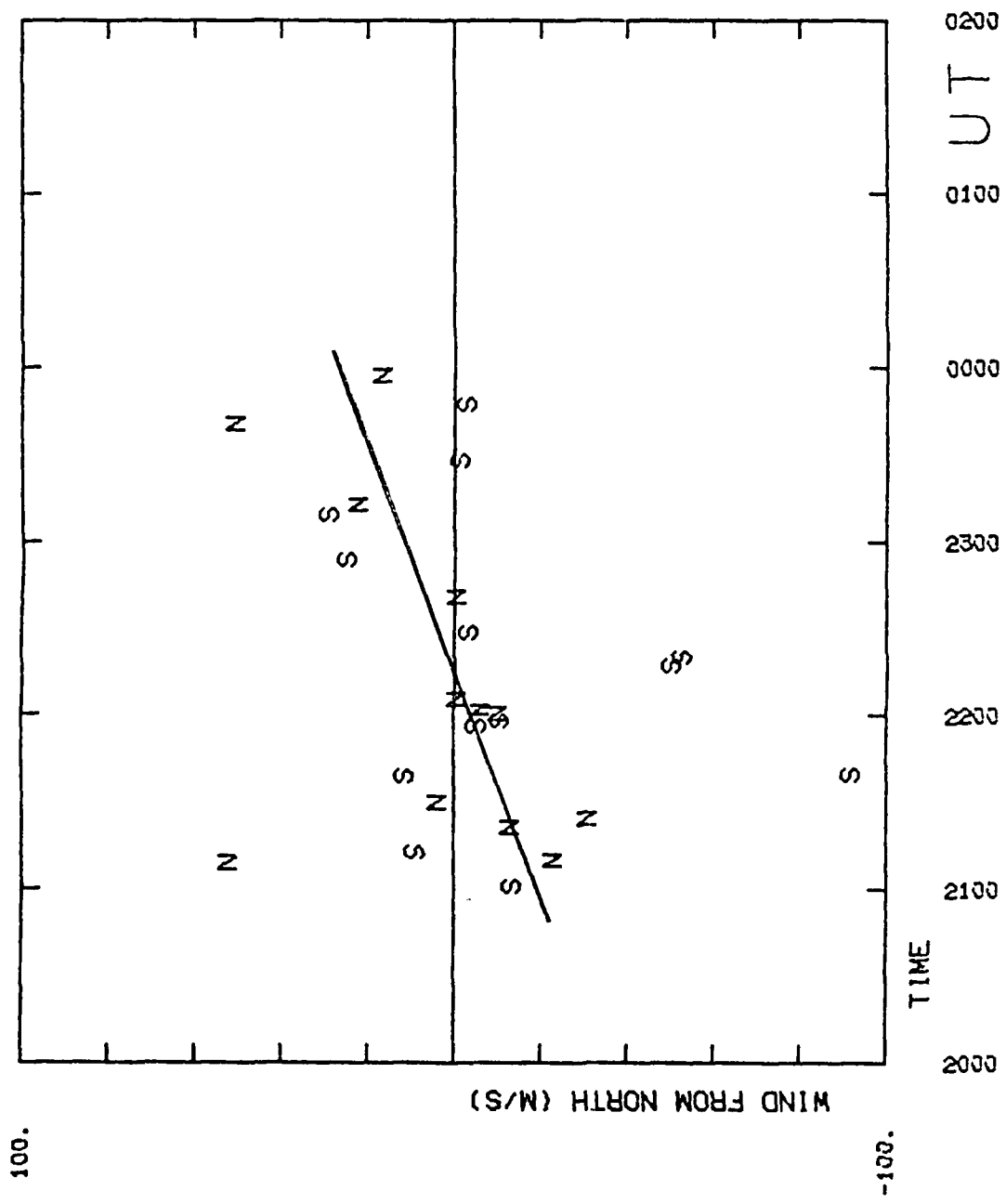

Fig. 5 Vertical motion of the neutral thermosphere (F-region) measured on 26 Aug. 1982. Positive values correspond to upward velocities (in m/s).



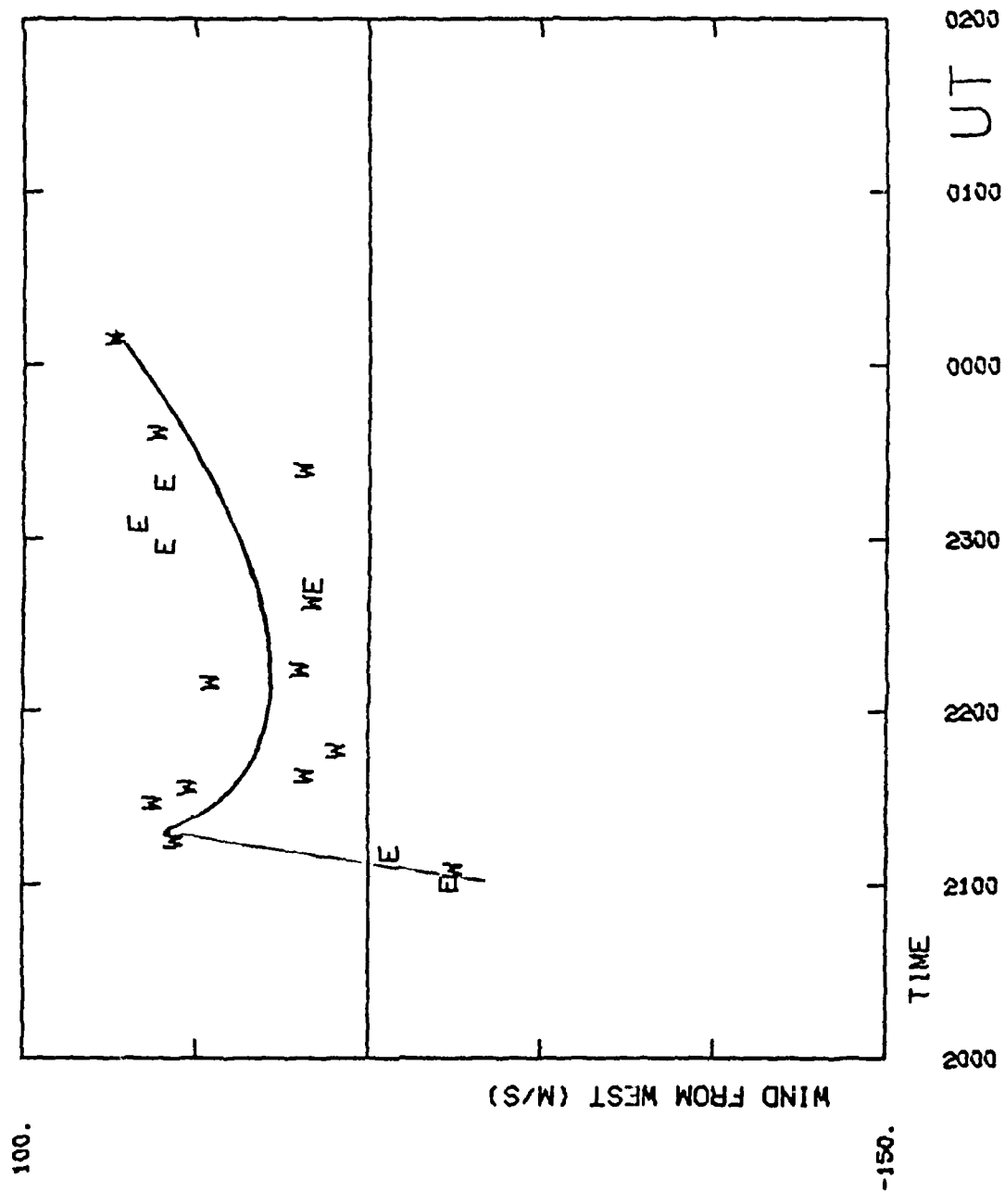

Fig. 7 Zonal winds measured on 6 September 1962.

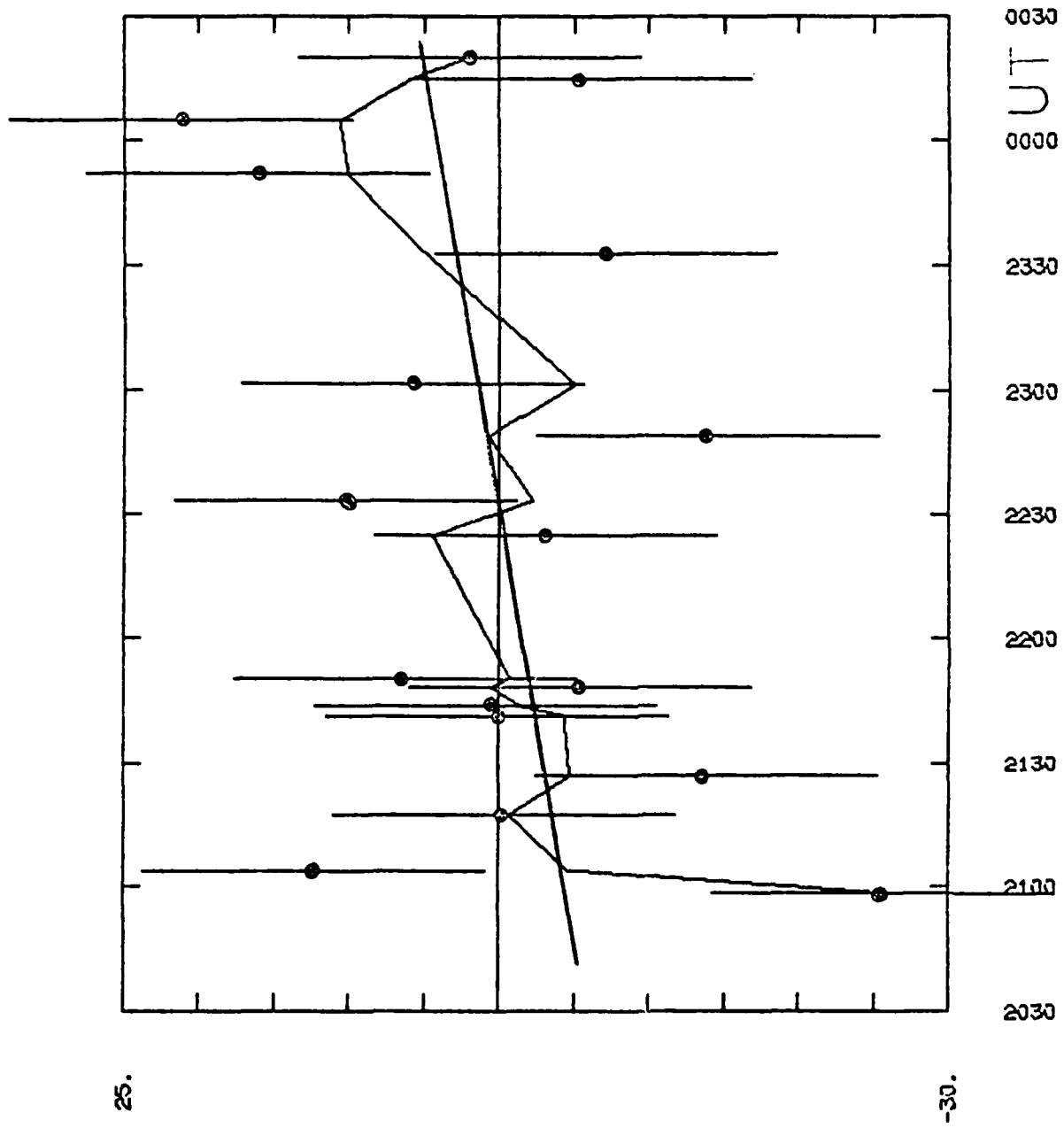

Fig. 8 Vertical motions (velocities in m/s) measured on 6 Sept. 1982.

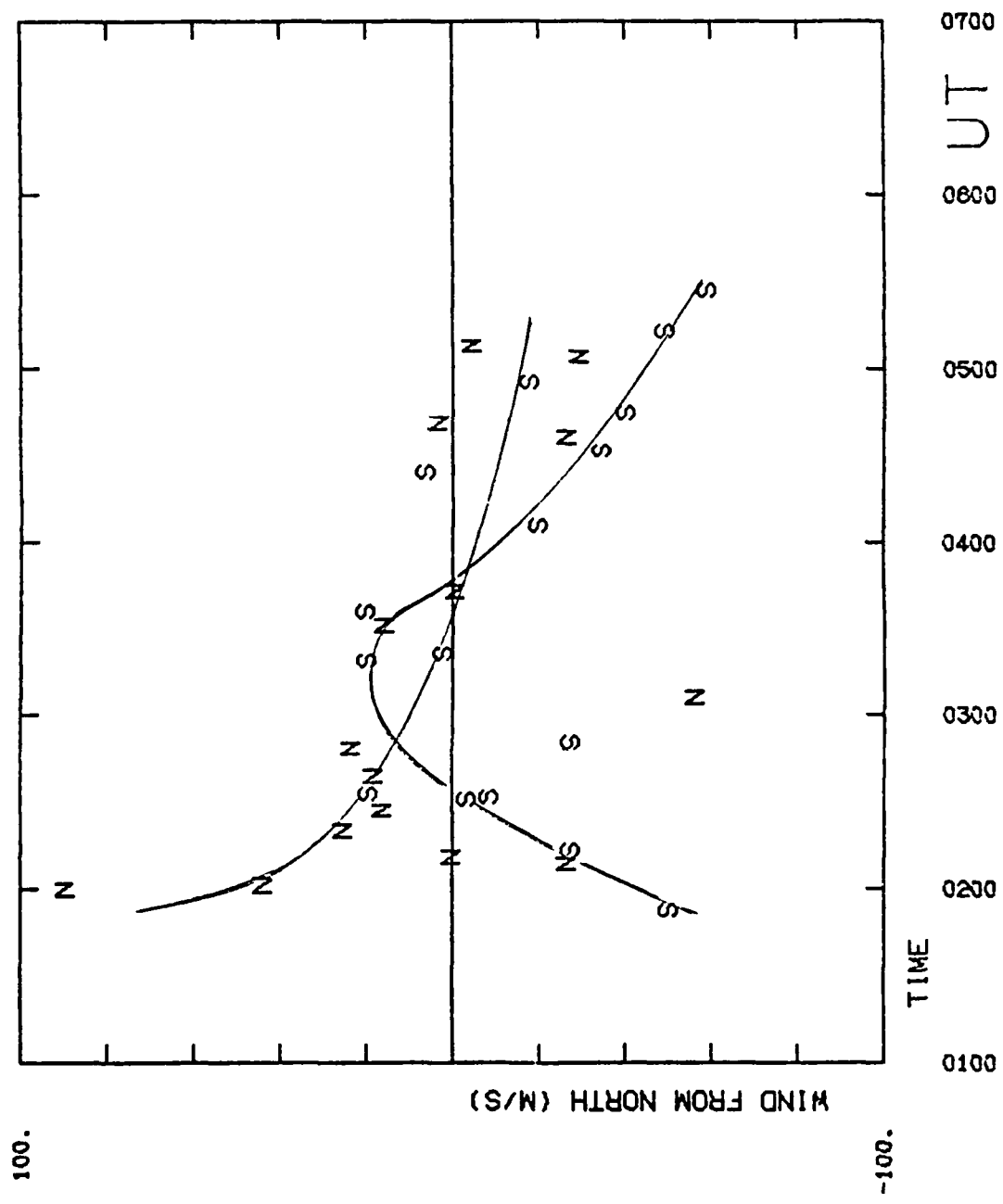

Fig. 9 Meridional winds measured at Natal, Brazil on 11 Sept. 1982.

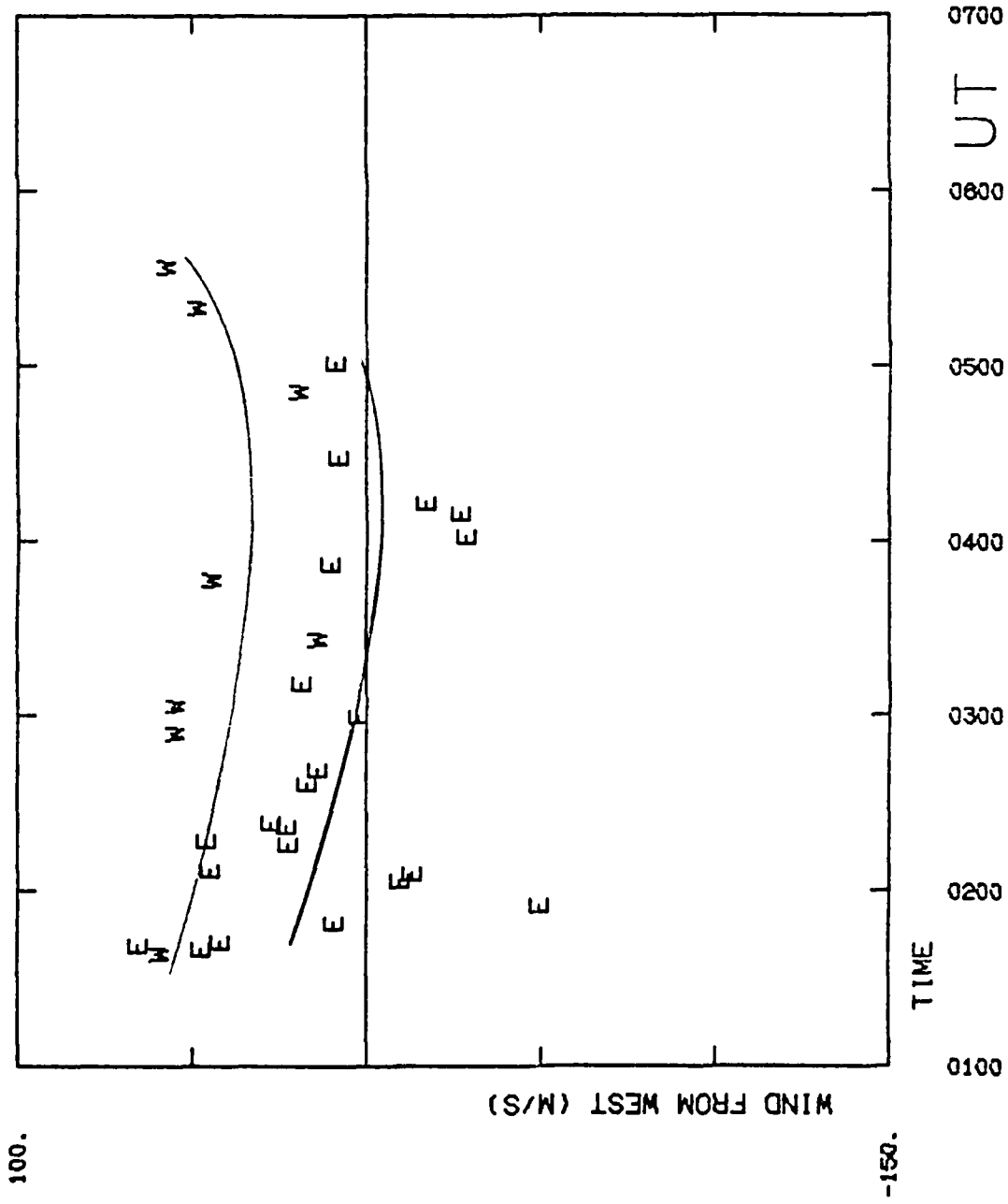

Fig. 10 Zonal winds measured on 11 September 1982.

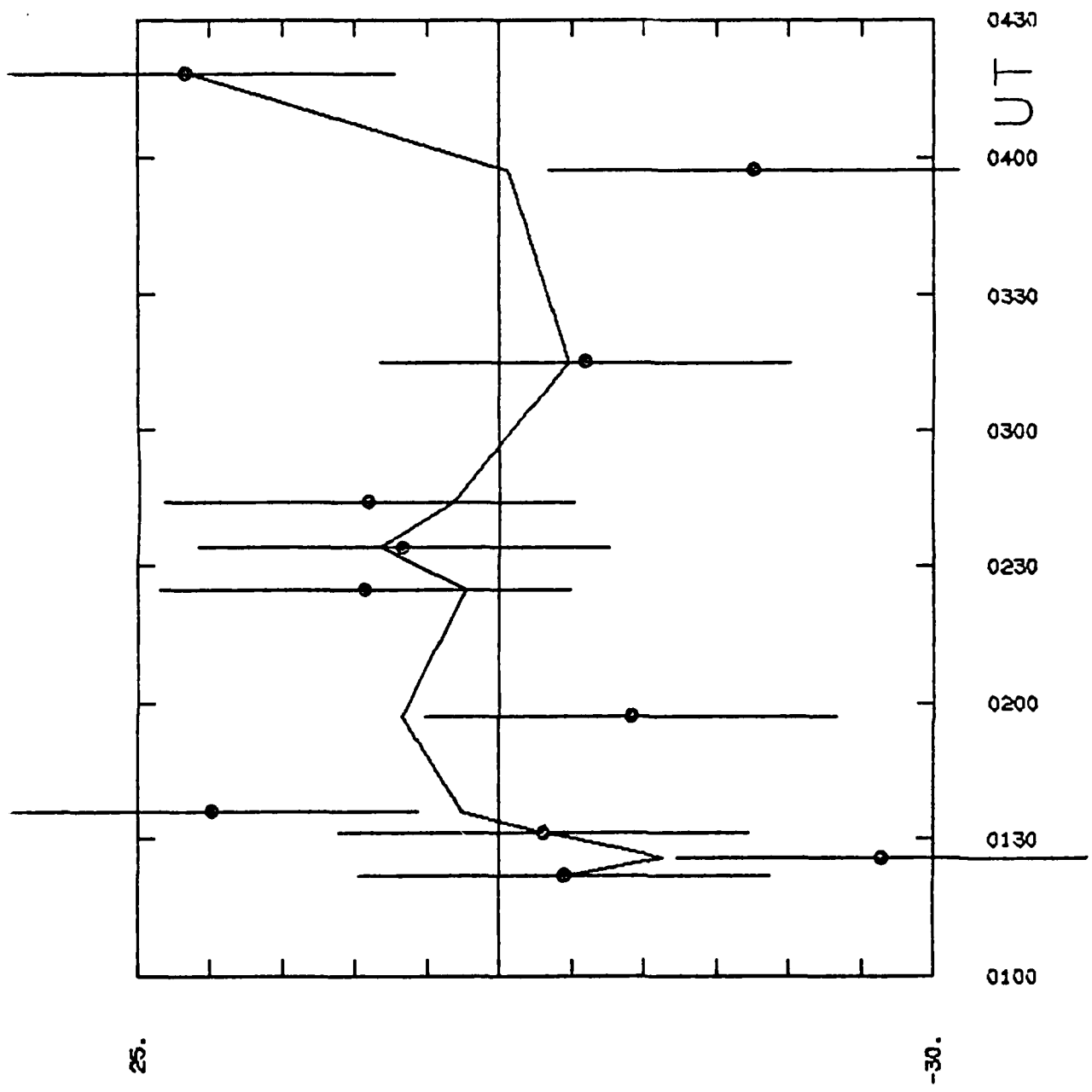

Fig. 11 Vertical motions (in m/s) measured on 11 September 1982.

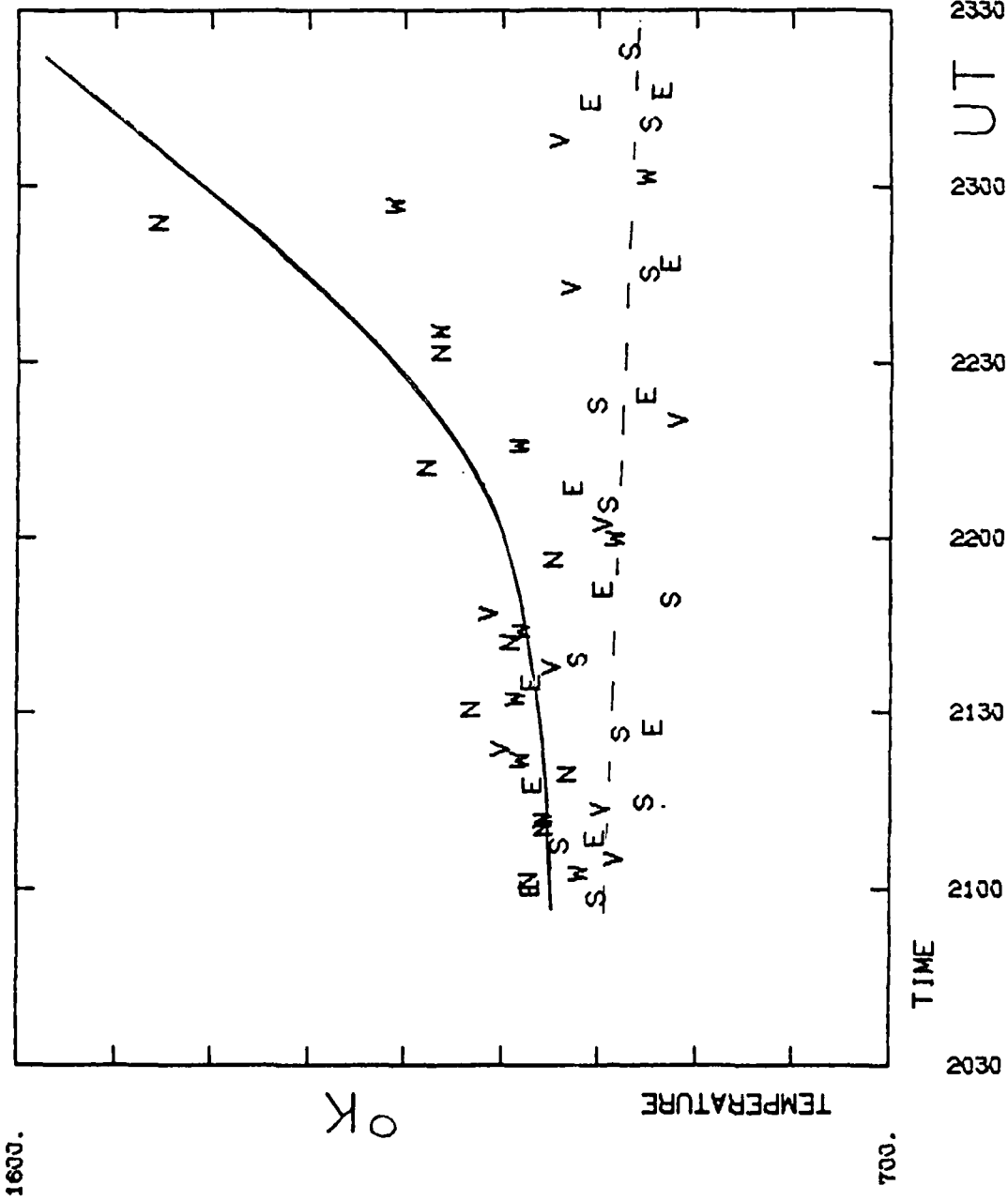

Fig. 12 Neutral Thermosphere's temperature, 26 August 1982, at Natal, Brazil.

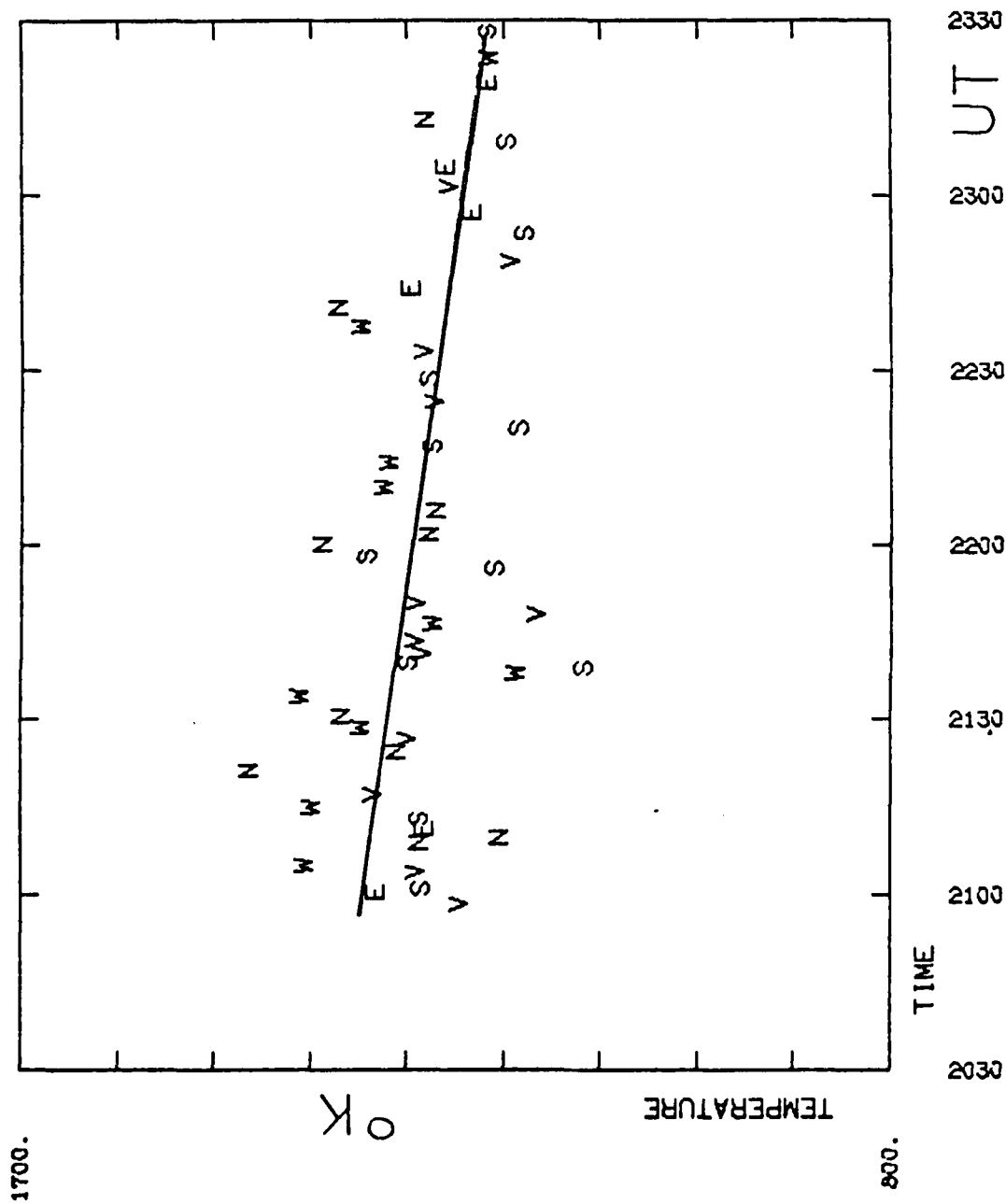

Fig. 13 Thermospheric temperature, 6 Sept. 1982, at Natal.

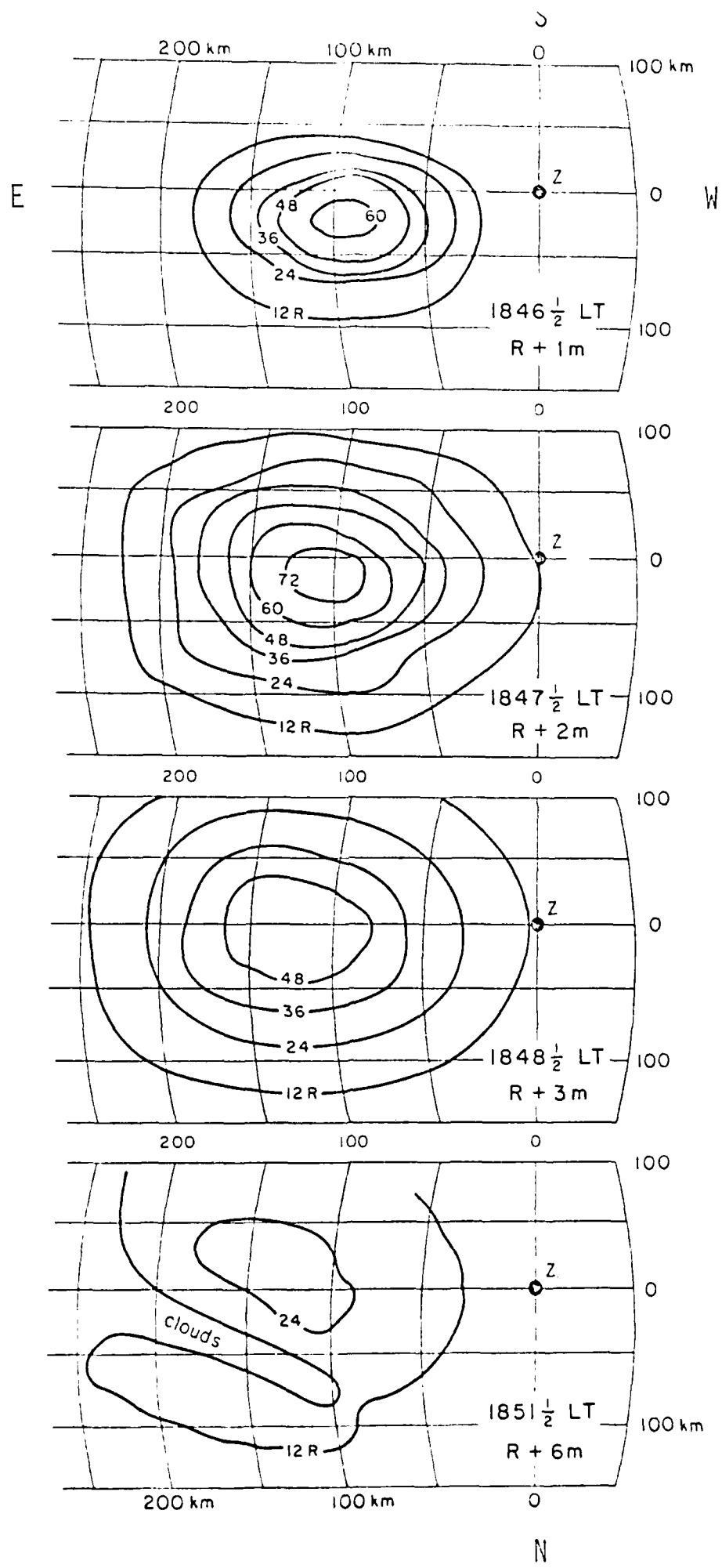

Fig. 15 630.0 nm airglow enhancement produced by the BIME release of 8 Sept. 1982 at 1845 $\frac{1}{2}$ LT.

END

FILMED

9-83

DTIC