

MICROCOPY RESOLUTION TEST CHART
NATIONAL BUREAU OF STANDARDS-1963-A

2

FTD-ID(RS)T-0015-83

FOREIGN TECHNOLOGY DIVISION



DISCUSSION OF STATIC PRESSURE LIQUID-FLOATED GYROS

by

Zhang Guoan



S DTIC
ELECTE **D**
AUG 26 1983
E

Approved for public release;
distribution unlimited.

ADA 131874

DTIC FILE COPY



88 08 25 153

EDITED TRANSLATION

FTD-ID(RS)T-0015-83

3 August 1983

MICROFICHE NR: FTD-83-C-000946

DISCUSSION OF STATIC PRESSURE LIQUID-FLOATED GYROS

By: Zhang Guoan

English pages: 6

Source: Hankong Zhishi, Nr. 10, October 1982,
pp. 20-21

Country of origin: China

Translated by: Randy Dorsey

Requester: FTD/SDBS

Approved for public release; distribution unlimited.

| | |
|---------------------|-------------------------------------|
| Accession For | |
| NTIS GRA&I | <input checked="" type="checkbox"/> |
| DTIC TAB | <input type="checkbox"/> |
| Unannounced | <input type="checkbox"/> |
| Justification | |
| By _____ | |
| Distribution/ _____ | |
| Availability Codes | |
| Dist | Avail and/or Special |
| A | |



| | |
|---|---|
| <p>THIS TRANSLATION IS A RENDITION OF THE ORIGINAL FOREIGN TEXT WITHOUT ANY ANALYTICAL OR EDITORIAL COMMENT. STATEMENTS OR THEORIES ADVOCATED OR IMPLIED ARE THOSE OF THE SOURCE AND DO NOT NECESSARILY REFLECT THE POSITION OR OPINION OF THE FOREIGN TECHNOLOGY DIVISION.</p> | <p>PREPARED BY: TRANSLATION DIVISION FOREIGN TECHNOLOGY DIVISION WP-AFB, OHIO.</p> |
|---|---|

GRAPHICS DISCLAIMER

All figures, graphics, tables, equations, etc. merged into this translation were extracted from the best quality copy available.

DISCUSSION OF STATIC PRESSURE LIQUID-FLOATED GYROS

Zhang Guoan

During the early stages of development of the gyroscope, air-floated gyros went through a flourishing period. In the last ten years or so, an improvement overseas in the field of air-floated gyro technology is that the gas has been replaced by a thin oil. This oil is continuously pumped to the bearings supporting the gimbal shaft by a miniature pump incorporated in the gyroscope itself. The oil circulates inside the housing and a self-feed type static pressure liquid-floated gyro is formed.

By looking at the history of the development of the gyroscope it can be clearly seen that along with the development of inertial guidance technology a great variety of types of gyroscopes appeared. Although they varied greatly their component parts were still high-speed rotors and gimbals. The only differences were the different gimbal support shapes and the gyroscopes were simply named according to the type of shape of the gimbal support. What is the reason for this? Because in practice over a long period people have come to the realization that of the many kinds of interference moments of force the friction moment of force in the gimbal support is the primary factor which destroys the accuracy of the instrument. Consequently, in the last several decades, by simply altering the method of gimbal support new types of gyroscopes have been developed.

In the 1950s, the Bendix Company of the U. S. first used static pressure air-floated bearings to replace the ball bearings of support gimbals and succeeded in developing air-floated gyros, making possible a major advancement in the accuracy of gyroscopes. On 31 January 1958

the U. S. successfully launched its first artificial earth satellite, "Explorer 1", using a "Jupiter C" launch vehicle and on 20 July 1969, accomplished the "Apollo" moon landing flight using a Huge "Saturn V" launch vehicle. The inertial guidance instruments used by these launch vehicles were air-floated gyros. The successful launches of the "Saturn V" and "Jupiter C" launch vehicles are inseparable from the high accuracy of the air-floated gyros. Moreover, air-floated gyros also have the distinguishing features of design and production simplicity and low cost.

Air-floated gyros, like other things, also have their shortcomings. First of all, they are not self-feeding type gyros, they require an external air source which greatly hampers operation. Secondly, further improvements in accuracy involves extreme difficulties.

U. S. and West German manufacturers which make air-floated gyros, in order to enhance their ability to compete with other gyroscopes, began posing such new problems in the early 60s, which required both the use of air-floated gyro production lines and ample practical experience as well as the elimination of such vestiges as the auxiliary air tanks required by air-floated gyros. Further, accuracy also had to be somewhat improved. After long effort and probing, finally a shortcut was discovered which involved a short production cycle, lower cost and which was suited to the characteristics of those factories. Thus, the air-floated gyro was transformed into a static pressure liquid-floated gyro. The random shift of the gyro was decreased from the original $.03^{\circ}$ /hour to $.01^{\circ}$ /hour or even $.001^{\circ}$ /hour. They also switched to a self-feed type gyro not requiring an external air supply.

What are the principles of operation and the structure of the static pressure liquid-floated gyro with single degree of freedom? Let's begin this discussion with air-floated gyros.

Air-floated gyroscope gimbals are supported by both journal and thrust type static pressure air-floated bearings and, as shown on the left of Figure 1, the journal type air-floated bearings provide support in the up and down direction and the thrust type air-floated bearings provide support in the right and left direction and limit

the movement of the floating shaft. Its operating process is as follows: gas is supplied from the external air tank, the electro valve opens, the gas passes through a pressure reducer, a filter, and a small restricted orifice in the bearing housing (or other restricted, narrow passage), enters the bearing clearance, and then flows out around the outer edges at both ends. Due to the weight of the floating shaft itself and the effect of acceleration during flight, the floating shaft moves downward in the direction of externally applied force and as a result the clearance at the top of the bearing becomes greater and the clearance at the bottom less; with a large clearance at the top of the bearing, the resistance to air flow decreases, the rate of flow increases and the pressure loss of the flow through the restricted orifice also increases, consequently, the pressure in the top clearance of the bearing $P_{b\uparrow}$ correspondingly decreases. On the other hand, with a small clearance at the bottom of the bearing, the resistance to air flow is great, the rate of flow is small and the pressure loss of the flow through the restricted orifice is small, thus causing the pressure inside the clearance at the bottom of the bearing $P_{b\downarrow}$ to decrease. As a result, there arises a pressure difference between the top and bottom surfaces of the floating shaft. This pressure difference simply equalizes the applied load. Assuming that the floating shaft is subjected to external force and moves toward the right end, this results in a decrease in the left end clearance and an increase in the right end clearance. It is the same principle as that described above. The clearance on the left side is small, resistance to air flow is greater and the pressure increases; the clearance on the right side is great, the resistance to air flow is less and the pressure decreases. Thus, a pressure difference exists between the two end surfaces of the shaft. This pressure difference is just enough to equalize the external forces. Thus, the floating shaft is provided with a very thin film of air around its entire circumference to separate it from the bearing housing. There is no mechanical contact and friction drag is very little, therefore, it is a fairly ideal gimbal support. Naturally, the precision of the gyroscope is greatly improved over those which employ ball bearings. The AB-5 air-floated gyro (which was used in the Saturn V launch vehicle) built by the Bendix Company of the U. S. has a random shift of $.01^\circ/\text{hour}$ and the GWK air-floated gyro built by the West German Teldix

Company has a random shift of $.05^\circ/\text{hour}$.

It can be seen from the left side of Figure 1 that the air-floated gyro must also be equipped with an air tank and a complicated air delivery system. The weight and bulk of this auxiliary equipment is tens of times greater than that of the gyro itself. As a result, in certain cases the use of air-floated gyros is limited. On the other hand, air-floated bearings must have sufficiently large supporting capacity to be able to ensure that the gyro operates properly under fairly great overload conditions. The pressure of the supply air P_0 must not be less than 1kg/cc . Consequently, the speed of the air flow in the bearing clearance is fairly high. In addition, the bearing housing and the shaft cannot be perfectly symmetrical, or relatively large, harmful rotational flow moments are apt to be created on the floating shaft. This is the main reason that the accuracy of the air-floated gyro is not very good.

In the early 60s, the Bendix Company of the U. S. began to study this vestigial problem of how to eliminate the air supply of the air-floated gyro. Many types of miniature air compressors were developed one after another which were intended to be installed in the launch vehicle instrument bay along with the gyroscope. But since the inherent efficiency of the air compressor was low and its bulk great, even though research had been carried out for ten years, it still ended in failure.

Up to now the problem has not been resolved at all and as a result of this failure engineers and technicians have continued to sum up the lessons of the experience and to make new attempts. Taking into consideration the low bulk and the high efficiency of the hydraulic pump, could it be that the air-floated gyro will not work with air but will work with oil? They performed a daring experiment. They pumped thin F-113 oil into an AB-5 gyro using a miniature centrifugal pump. The results of the test were ideal. Thus began the research into static pressure liquid-floated gyros. The principles of construction of the static pressure liquid-floated gyro are basically the same as that of the air-floated gyro. However, the hydraulic pump is often attached to one end of the air-floated gyro and the

outer housing is filled with oil (see right side of Figure 1).

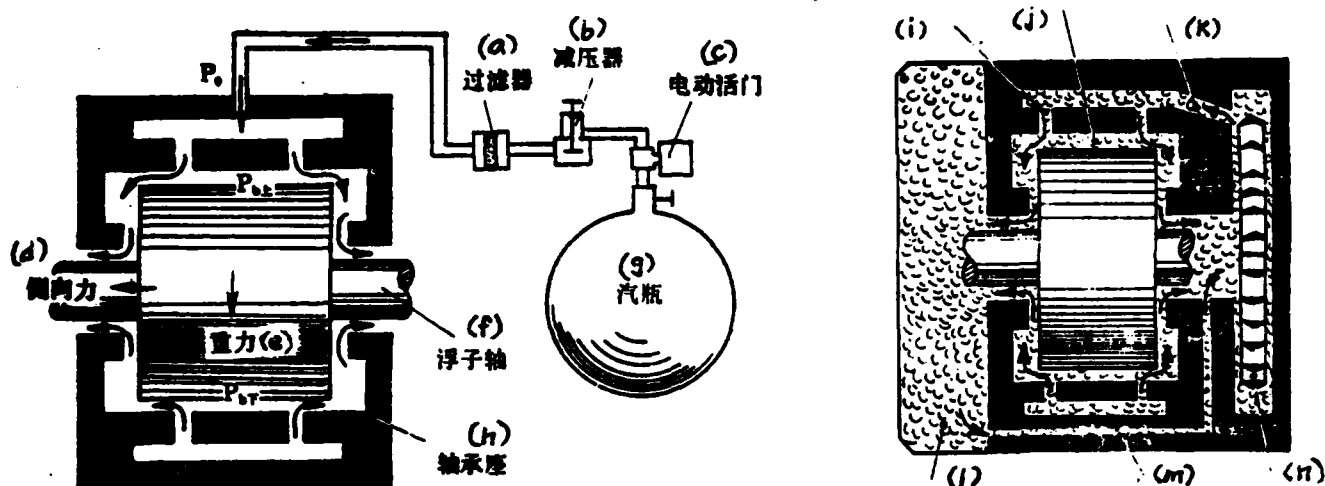

Fig. 1. Diagram of the operating process of the air-floated gyro (left) and of a static pressure liquid-floated gyro (right).

KEY: (a) filter; (b) pressure reducer; (c) electro valve; (d) lateral force; (e) gravity; (f) floating shaft; (g) air tank; (h) bearing housing; (i) flow restricting orifice; (j) bearing clearance; (k) oil feed passage; (l) oil; (m) oil return passage; (n) oil pump

The operating process of the static pressure liquid-floated gyro is as follows: oil pumped out at fixed pressure passes through the oil feed passage, through the restricting orifices in the bearing housing, through the bearing clearance and out through both ends. The oil from the right end returns directly to the pump inlet; the oil from the left end passes through the oil return passage and back to the pump inlet. Then the pump again pumps the oil to the bearings. When oil flows through the bearing clearance, the floating shaft is supported and the principle of operation is the same as that of the air-floated bearing. The difference is that the circumference of the floating shaft is separated from the bearing housing by a very thin film of oil. The oil, just like human blood, circulates continuously. The pump is simply the heart of the static pressure liquid-floated gyro.

The static pressure liquid-floated gyro is a self-feeding type and does not required an external oil source and, since the air has been replaced by oil, damping of the floating shaft is markedly increased. In addition, the flow rate of the oil inside the bearing

clearance is much slower than that of the air. Therefore, the moment of interference on the floating shaft is lessened which serves to improve gyro accuracy. A diagram of its structure is shown in Fig. 2.

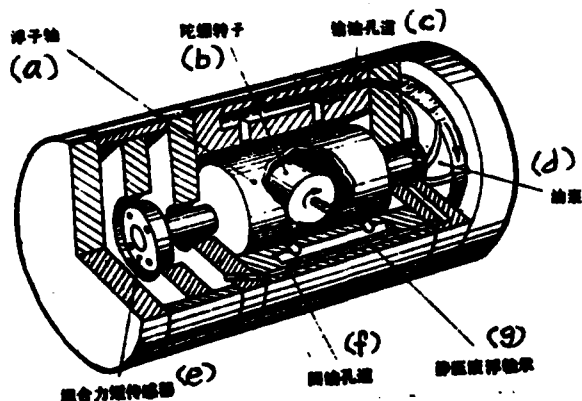

Fig. 2. Diagram showing the structure of a static pressure liquid-floated gyro with single degree of freedom.

KEY: (a) floating shaft; (b) gyro rotor; (c) oil feed passage; (d) oil pump; (e) combination moment of force sensor; (f) oil return passage; (g) static pressure liquid-floated bearing

However, since the static pressure liquid-floated gyro uses oil and not air, testing and sealing of the gyro is much more complicated than for the air-floated gyro and the degree of difficulty of production is also somewhat greater.

The static pressure liquid-floated gyro is an inevitable outgrowth of the air-floated gyro and it has its advantages, but the accuracy of the static pressure liquid-floated gyro is higher, its speed adaptability is good, it has relatively high carrying capacity at various rates of relative motion, it has good anti-vibration qualities and a wide range of applications. However, with regard to its conditions of operation, it must be operated within a certain temperature range; with regard to its testing, balance testing of its output shaft in oil is somewhat more difficult than for an air-floated gyro. With regard to manufacturing, it is somewhat more complicated than the air-floated gyro.

In a word, the advantages of the static pressure liquid-floated gyro are outstanding. It has already found use in the inertial guidance systems of "Polaris", "Trident", and "Poseidon" submarines.