

MICROCOPY RESOLUTION TEST CHART
NATIONAL BUREAU OF STANDARDS-1963-A

12

AD A 131 959

R-1259

XCTD PHASE I PROGRESS REPORT

(13 July 1983)

Contract N00014-82-C-0579

DTIC

JUL 1983

E

Sippican Ocean Systems, Inc.
Marion, Massachusetts

DTIC FILE COPY

Approved for Release by NSA on 05-08-2014 pursuant to E.O. 13526

83 08 18 019

TABLE OF CONTENTS

	Page
1.0 INTRODUCTION	1-1
2.0 EXPENDABLE, CONDUCTIVITY, TEMP. DEPTH (XCTD) SYSTEM	1-2
2.1 XCTD Probe	1-4
2.2 XCTD Probe Electronics	1-4
2.3 Operational	2-1
2.4 Electrical	2-2
2.5 Power	2-3
3.0 SYSTEM OPERATION	3-1
3.1 Laboratory Set-up	3-1
3.2 XCTD Communication and Timing	3-1
3.3 Calibration and Test Requirements	3-3
3.4 Data Processing and Software	3-3
3.4.1 Initialization	3-4
3.4.2 Calibration	3-5
3.4.3 Pre-Lab Measurement	3-7
3.4.4 Lab Measurement	3-7
3.5 Summary	3-8
4.0 CIRCUIT ACCURACY	4-1
4.1 Sensor Error Contribution	4-1
4.1.1 Conductivity Sensor Error Contribution	4-1
4.1.2 Temperature Sensor Error Contribution	4-2
4.2 Probe Processing Electronics	4-2
4.3 MK9 Data Recorder XCTD Interface	4-3
5.0 CIRCUIT STABILITY	5-1
6.0 SYSTEM MEASUREMENT ACCURACY	6-1
6.1 Conductivity	6-1
6.2 Temperature	6-1

LIST OF ILLUSTRATIONS

- 2.0-1 XCTD SYSTEM CONFIGURATION
- 2.0-2 XCTD PROBE LAYOUT
- 2.0-3 XCTD PROBE FUNCTIONAL BLOCK DIAGRAM
- 3.0-1 LAB TEST SET-UP
- 3.0-2 XCTD DATA TRANSMISSION FORMAT
- 3.0-3 BT 2 CONDUCTOR WIRE SIGNAL ATTENUATION
- 3.0-3 LAB TESTING SOFTWARE FLOW DIAGRAM
A-D
- 3.0-4 XCTD "R/F" LINE EQUATION
- 3.0-5 CALIBRATION PHASE PRINTOUT (CONDUCTIVITY)
- 3.0-6 PRELAUNCH EQUATION
- 3.0-7 MEASUREMENT PHASE PRINTOUT (CONDUCTIVITY)
- 3.0-8 CALIBRATION/MEASURE BLOCK DIAGRAM
- 7.0-1 THERMISTOR TIME RESPONSE
- 8.0-1 XCTD CONDUCTIVITY CELL
- 8.0-2 XCTD CONDUCTIVITY CELL MODEL

LIST OF TABLES

- I. OVERALL SYSTEM ACCURACY
- II. CIRCUIT GAIN STABILITY
- III. CIRCUIT OFFSET STABILITY
- IV. CONDUCTIVITY ACCURACY TEST
- V. TEMPERATURE ACCURACY TEST

1.0 INTRODUCTION

Sippican under Contract N00014-82-C-0579 is developing an Expendable Conductivity and Temperature probe (XCTD). Phase I of that contract, as defined in Report R-1087A, encompasses the conceptual design and laboratory testing of temperature and conductivity sensors and associated circuitry for the expendable probe. This report describes the activities and results of Phase I of this contract. The report is an overall description of the XCTD probe and its progress to date. A general description of the circuit operation, lab setup, calibration procedures, software and data formatting, transmission, detection and processing is presented. The attained system accuracies, the sources of inaccuracies and how they might be improved in the final configuration is also presented. Descriptions of the model conductivity cell, thermistor, and model probe are included along with their performance test results. Finally, in the last section the remaining major design areas are outlined.

2.0 EXPENDABLE, CONDUCTIVITY, TEMPERATURE, DEPTH (XCTD) SYSTEM

The XCTD System, as presently configured, is shown in Figure 2.0-1. The free falling XCTD probe transmits time multiplexed frequency modulated data up a standard 39 gauge BT wire pair. The time multiplexed data consists of sequential samples of conductivity, temperature and calibration data. The BT wire is terminated at the hand, deck, or thru-hull launcher and interfaced to the Sippican MK-9 Recorder with an XCTD card set via the launcher cable. The MK9 Recorder demultiplexes the data samples and measures the frequency of the appropriate data samples. These data samples are transferred to the Hewlett Packard 85 desk top computer where real time calibration data is compared to initial (time of manufacture) calibration data to determine any changes in gain and offset of the electronics. These changes in gain and offset are used to correct the real time conductivity and temperature data. The corrected data is displayed on the HP85 display, printed on the printer and stored on the cassette. The data reduction and display performed by the HP85 occurs almost simultaneously with the probes descent, so data is available very nearly real time.

The accuracy requirements for the XCTD system were defined in Sippican Report R-1087A as ± 0.03 mmho for conductivity and $\pm 0.03^\circ\text{C}$ for temperature. An initial assessment of sensor, electronics and processing errors resulted in the following apportionment of allowable tolerances and errors.

	<u>Sensor</u>	<u>Probe Electronics</u>	<u>Deck Gear Processing</u>
Conductivity	0.01 mmho	0.01 mmho	0.01 mmho
Temperature	0.01°C	0.01°C	0.01°C

12 PROBES PER CASE
HP CASSETTE WITH CAL SHEET

SIPPICAN OCEAN SYSTEMS MK9
WITH XCTD CARD SET

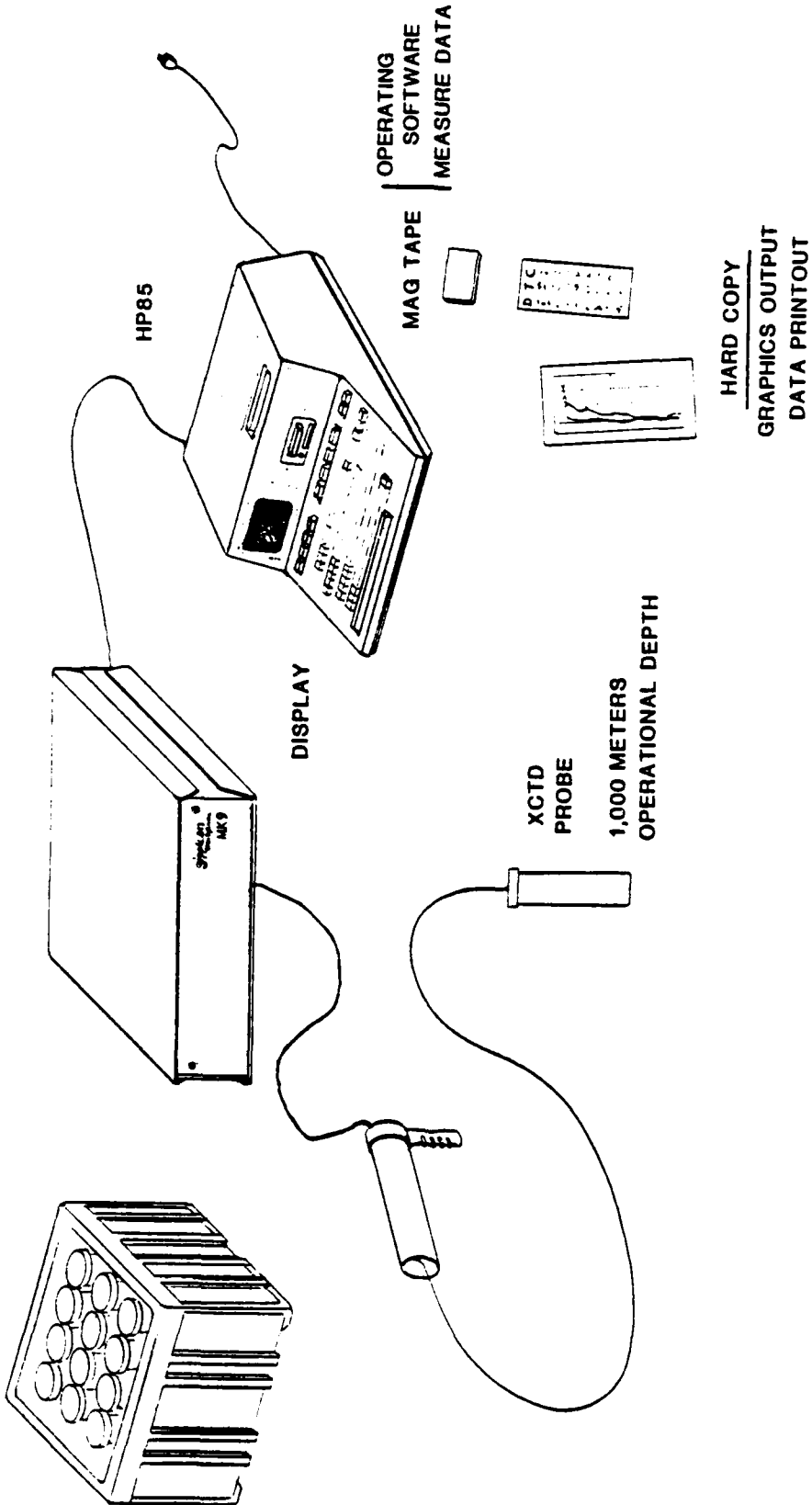

XCTD SYSTEM CONFIGURATION

FIGURE 2.0-1

2.0 EXPENDABLE, CONDUCTIVITY, TEMPERATURE, DEPTH (XCTD) SYSTEM

The XCTD System, as presently configured, is shown in Figure 2.0-1. The free falling XCTD probe transmits time multiplexed frequency modulated data up a standard 39 gauge BT wire pair. The time multiplexed data consists of sequential samples of conductivity, temperature and calibration data. The BT wire is terminated at the hand, deck, or thru-hull launcher and interfaced to the Sippican MK-9 Recorder with an XCTD card set via the launcher cable. The MK9 Recorder demultiplexes the data samples and measures the frequency of the appropriate data samples. These data samples are transferred to the Hewlett Packard 85 desk top computer where real time calibration data is compared to initial (time of manufacture) calibration data to determine any changes in gain and offset of the electronics. These changes in gain and offset are used to correct the real time conductivity and temperature data. The corrected data is displayed on the HP85 display, printed on the printer and stored on the cassette. The data reduction and display performed by the HP85 occurs almost simultaneously with the probes descent, so data is available very nearly real time.

The accuracy requirements for the XCTD system were defined in Sippican Report R-1087A as ± 0.03 mmho for conductivity and $\pm 0.03^\circ\text{C}$ for temperature. An initial assessment of sensor, electronics and processing errors resulted in the following apportionment of allowable tolerances and errors.

	<u>Sensor</u>	<u>Probe Electronics</u>	<u>Deck Gear Processing</u>
Conductivity	0.01 mmho	0.01 mmho	0.01 mmho
Temperature	0.01 $^\circ\text{C}$	0.01 $^\circ\text{C}$	0.01 $^\circ\text{C}$

It is noted that the contributing errors are summed directly to provide the ± 0.03 mmho and $\pm 0.03^\circ\text{C}$ total accuracy, rather than by the usual RMS method. This is to allow for worst case conditions with a preference to err on the safe side.

Preliminary analysis showed that for a suitable conductivity cell to be interchangeable, the dimensional accuracy required was not tolerable in an inexpensive expendable. For example, a tubular 3 or 4 electrode conductivity cell 8.0 " long by 0.157" I.D. requires a ± 0.000015 inch tolerance on its inside diameter in order to be accurate to ± 0.01 mmho. A similar case exists for the temperature sensor in that a device accurate to 0.01°C costs more than our total material budget for the XCTD probe.

The approach became to provide very stable resistor references in each probe and at the time of manufacture to calibrate the performance of an inexpensive but stable conductivity cell and an inexpensive but stable thermistor against the very stable resistors contained in each probe. At the time of probe deployment, the circuit performance with the reference resistors is compared to what it was when the probe was calibrated.

Any changes are calculated, and corrected for. This allows the accuracy of the conductivity cell and thermistor to be orders of magnitude less than before. The accuracy is obtained by factory calibration and stability.

The small drawback of this system is that the initial calibration data that is used to determine conductivity and temperature performance versus the reference resistors is unique to each probe and must be available at the time of probe deployment.

2.1 XCTD Probe

A prototype XCTD probe assembly, as shown in Figure 2.0-2, is comprised of a number of parts similar to other Sippican probe parts. The zinc nose provides a controlled rate of stable descent. The hole in the center provides water flow thru the glass tube of the conductivity cell. The electronics packages contain the batteries required for probe operation and the two printed circuit boards. Both the batteries and the P.C. boards are potted to ensure water integrity. The two outer electrodes of the four electrode conductivity cell protrude through the potting and are available to the outside water flow via holes in the probe afterbody. The afterbody houses the probe spool and attaches to the ABT canister spool. Both spools together contain approximately 2,560 meters of BT wire. This is sufficient for a 1,000 meter probe drop from a ship traveling at 12 knots. This is based on a probe sampling increment of 1 meter.

2.2 XCTD Probe Electronics

Functional

A block diagram of the XCTD circuit is presented in Figure 2.0-3. The basic function of the circuit is to sequentially measure the voltages across a high and low calibration resistors, a thermistor, and a conductivity cell, all connected in series, convert the four voltages to proportionate frequencies and transmit the frequencies as time multiplexed FM through a 2 conductor BT cable to a surface receiver. The thermistor resistance varies with temperature and the conductivity cell resistance varies with water conductivity. The key to an accurate measurement is knowing the exact resistance of R_{HI} and R_{LO} and knowing that they are stable with temperature and time. Vishay Type S102 resistors having a resistance tolerance of $\pm .005\%$ and a temperature coefficient of 1 part per million per $^{\circ}C$ are used. The voltages across the thermistor R_T and the conductivity cell R_S are therefore directly proportional to the voltages across

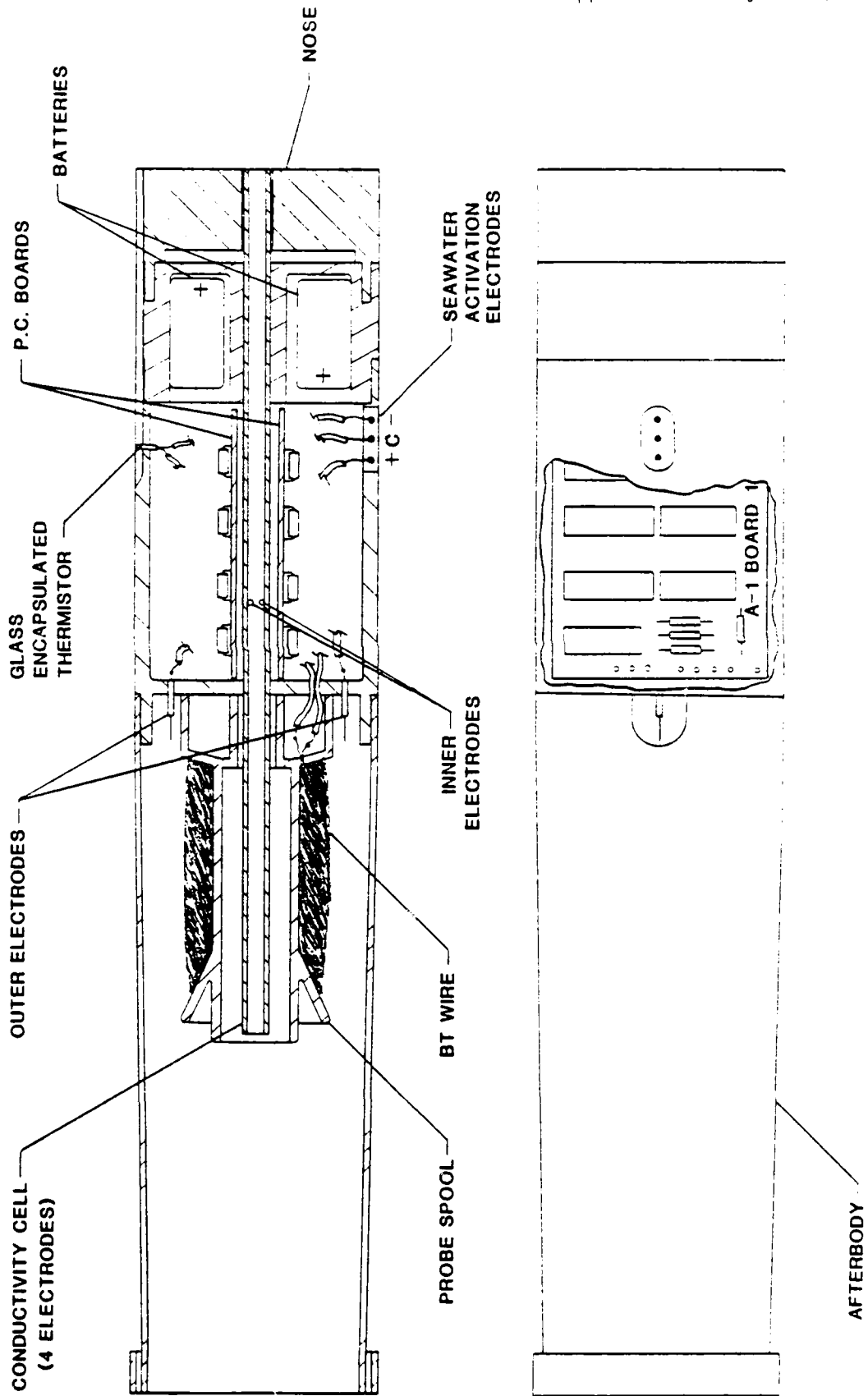

- PROTOTYPE -
XCID PROBE LAYOUT

FIGURE 2.0-2

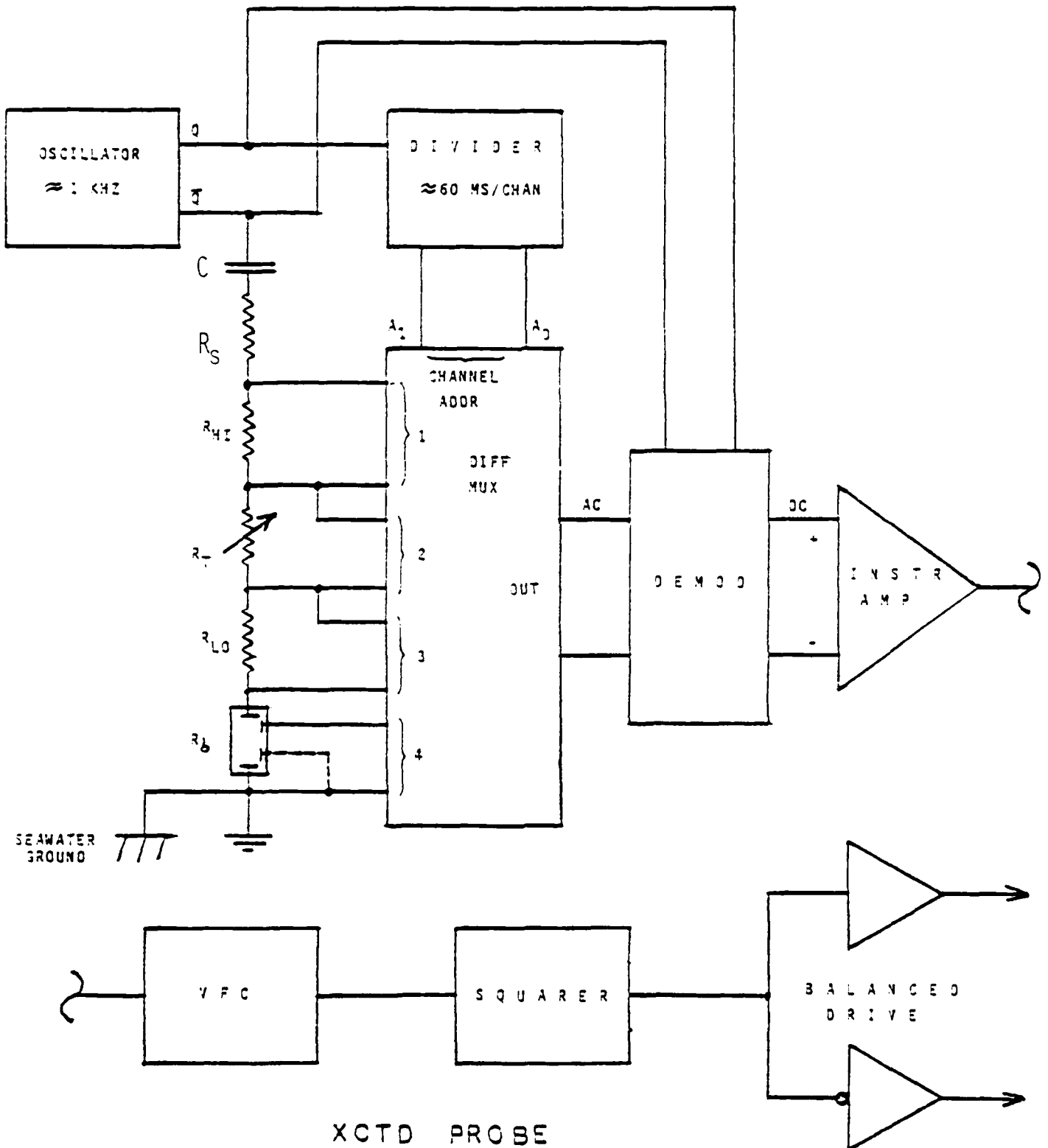

XCTD PROBE
FUNCTIONAL BLOCK DIAGRAM

FIGURE 2.0-3

R_{HI} and R_{LO} since at any one time the current through all the resistors is the same (assuming leakage and bias currents are zero). Using a balanced drive output all four frequencies are transmitted approximately four times a second through a 2 conductor BT cable to a surface receiver.

2.3 Operational

Referring again to the block diagram, the 1kHz oscillator is used to generate a square wave signal, which serves three functions as follows:

1. To drive the resistor chain consisting of R_S , R_{HI} , R_T , R_{LO} , and $R\delta$. The signal is AC coupled through the capacitor C thus providing a good symmetrical AC square wave.
2. To drive the divider which provides the channel address to the 4 channel differential multiplexer.
3. To drive the synchronous demodulator.

The AC voltages across R_{HI} , R_T , R_{LO} , and $R\delta$ are sequentially sampled by the differential multiplexer. The output of the multiplexer drives the synchronous demodulator, and the AC signal is converted to a DC signal of equal peak amplitude. This DC signal is amplified by the instrumentation amplifier, converted to a proportional frequency by the VFC (Voltage to Frequency Converter) and divided by two by the squarer for a 50% duty cycle square wave. Finally the signal is fed to a balanced driver, which drives the line with voltages of opposite polarity, reversing the polarities each $\frac{1}{2}$ cycle. This provides a very large voltage swing which compensates for the heavy wire attenuation. Also, the induced currents in the wire cancel each other thus minimizing circuit interference since battery ground is also seawater ground via the conductivity cell electrodes.

2.4 Electrical

A detailed schematic is attached. The 1kHz oscillator IC1 is a multi-vibrator. The frequency stability requirements will be dictated by the data receiving equipment and will be within the capabilities of IC1 - with the proper selection of external components. The \bar{Q} output drives the resistor chain R_S , R_{HI} , R_T , R_{LO} , and R_5 . The Q output drives the divider chain IC2, IC3, and IC4. Both the Q and \bar{Q} outputs are also the commutating signal for the quad bilateral switch IC6, which acts as the synchronous demodulator. A switch type demodulator, or commutator was used since it's response to changes in amplitude is fast compared to traditional type peak detectors. The output of the dividers provide the channel address to the differential multiplexer. Since the dividing chain divides the 1kHz oscillator signal by 120, the output of IC4 addresses each of the four channels for 60 ms each, thus the voltages across R_{HI} , R_T , R_{LO} , and R_5 are sampled for 60 ms each. The output of IC6 is fed to the differential input of the instrumentation amplifier IC7, whose high common mode rejection eliminates any common mode voltages and provides a ground referenced positive output.

The gain is 10 and is determined by external pin connections. The output of the amplifier is the input signal to the Voltage to Frequency Converter IC10 via the low pass R/C filter comprised of the 2K resistor and 1 μ f capacitor. This filter averages any ripple due to any imbalances (DC voltages) at the input to the differential multiplexer. The output of IC10 is a frequency proportional to the voltage input in the range of approximately 200 to 2200 hertz. The output frequency does not have the desired 50% duty cycle, and is thus squared by the divide by two circuit IC8. The resulting 100-1100 Hertz signal is AC coupled to a balanced driver output stage. When IC9, pin 12 is positive at about 6 volts, IC9 pin 10 is negative at about -6 volts. Therefore, IC9, pin 12, swings from 6 volts to -6 volts and IC9, pin 10, is simultaneously swinging from -6 volts to 6 volts thus the total voltage swing is 4 x 6 or 24 volts.

2.5 Power

The electronics is powered with four alkaline 9V batteries contained within the probe and provide a total of $\pm 18V$. The voltage is regulated down to ± 12 volts. The alkaline batteries can be expected to retain 70% of their original capacity after two years if stored at temperatures less than $30^{\circ}C$, and at circuit current drains of approximately 30 ma are capable of powering the probe throughout its descent. The major advantage in using alkaline batteries is their low cost. Activation of the probe electronics will be via three electrodes on the outside of the probe body. These electrodes will be commoned to circuit ground, which is also seawater ground, upon contact with seawater. This will in effect pull the negative battery and the positive battery to circuit ground, thus completing the power/ground circuit.

3.0 SYSTEM OPERATION

3.1 Laboratory Set-up

For the purposes of development testing of the electronics, conductivity cell, thermistor, and the accuracy demonstration of the final probe configuration, the lab set up shown in Figure 3.0-1, was assembled. The XCTD circuit as described in Section 2 is shown in the center. Its inputs are $\pm 12\text{VDC}$, R_T or a thermistor, and R_δ or a conductivity cell. The outputs are the instrumentation amplifier output and the divide by two squarer and these are connected to the HP3455A voltmeter and the HP5316A counter, respectively. A special interface circuit to properly gate the counter-to-measure time intervals is included in the XCTD breadboard. This interface circuit is not part of the normal probe electronics and its function will be included in XCTD deck gear. An HP85 computer sequentially inputs data from the voltmeter and the counter via an HP-IB interface bus and processes the data to determine temperature and conductivity. Subsequently, temperature and conductivity is also input as measured with the Neil Brown Model CT III Calibration Standard via the RS-232 link. The three seawater baths are mixed to provide three different levels of conductivity - low, middle, and high. These three conductivities are used to calibrate the conductivity cell. Similarly a microprocessor controlled temperature bath provides three levels of temperature to calibrate the thermistor. Both the temperatures and conductivities are known by measuring with the Neil Brown Standard. Also, temperature and conductivity can be independently profiled by varying the bath temperature and adding salt to the low conductivity bath, respectively.

3.2 XCTD Communication and Timing

The calibration temperature and conductivity data is contained both in the voltage and frequency outputs of the XCTD circuit. The data output is formatted as shown in Figure 4. In order to properly gate the counter, an interface circuit was breadboarded to output a single pulse enveloping 2, 4, 6, 8, or 10 cycles (selectable) of each channel at a predetermined delay from the beginning of each channel.

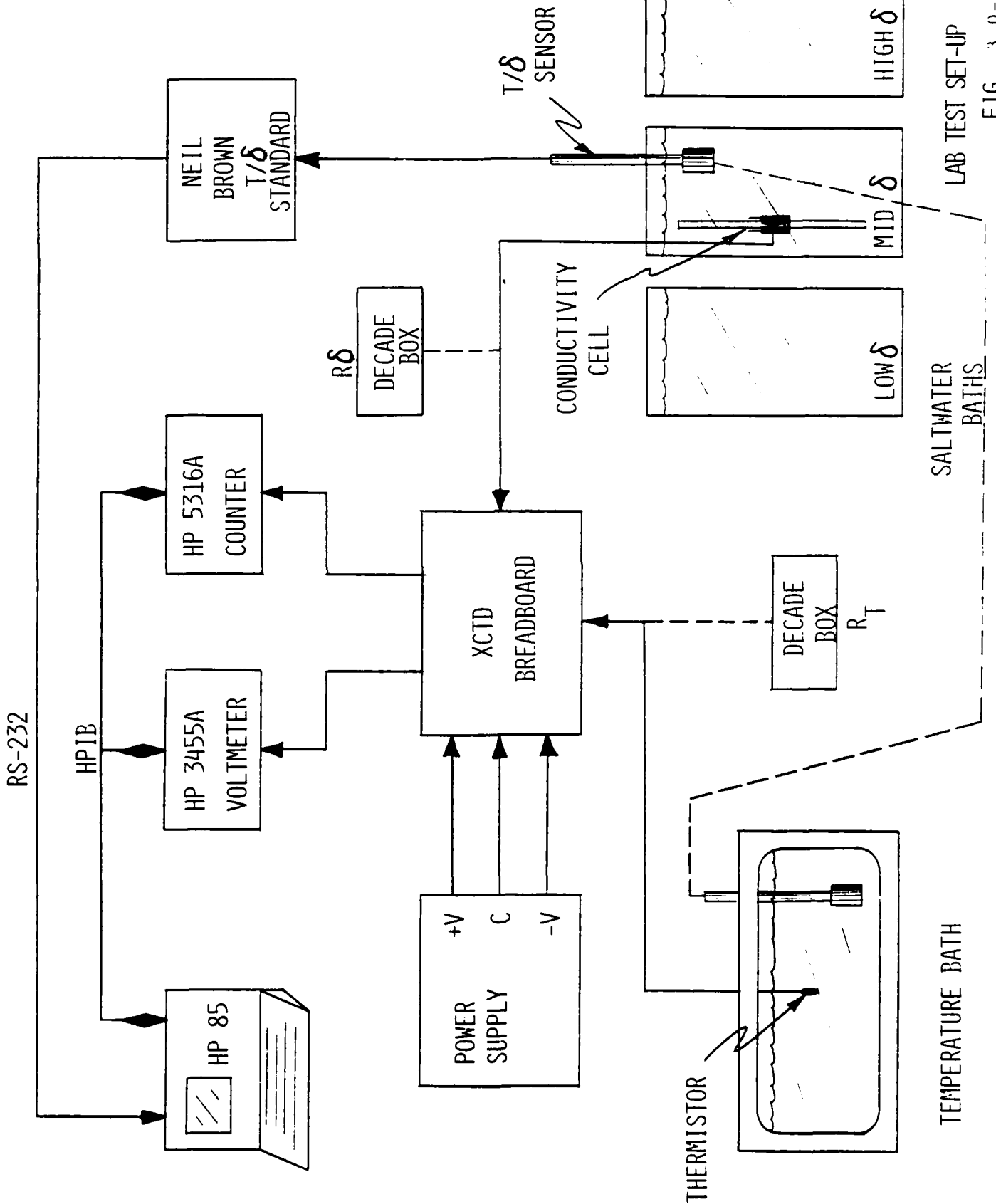

FIG. 3.0-1

RS-232

HPIB

HP 5316A
COUNTER

HP 3455A
VOLTMEETER

HP 85

R δ
DECAD E
BOX

+V
C
-V
POWER
SUPPLY

XCTD
BREADBOARD

DECAD E
BOX
R T

THERMISTOR

CONDUCTIVITY
CELL

T/δ
SENSOR

LOW δ

MID δ

HIGH δ

SALTWATER
BATHS

TEMPERATURE BATH

LAB TEST SET-UP

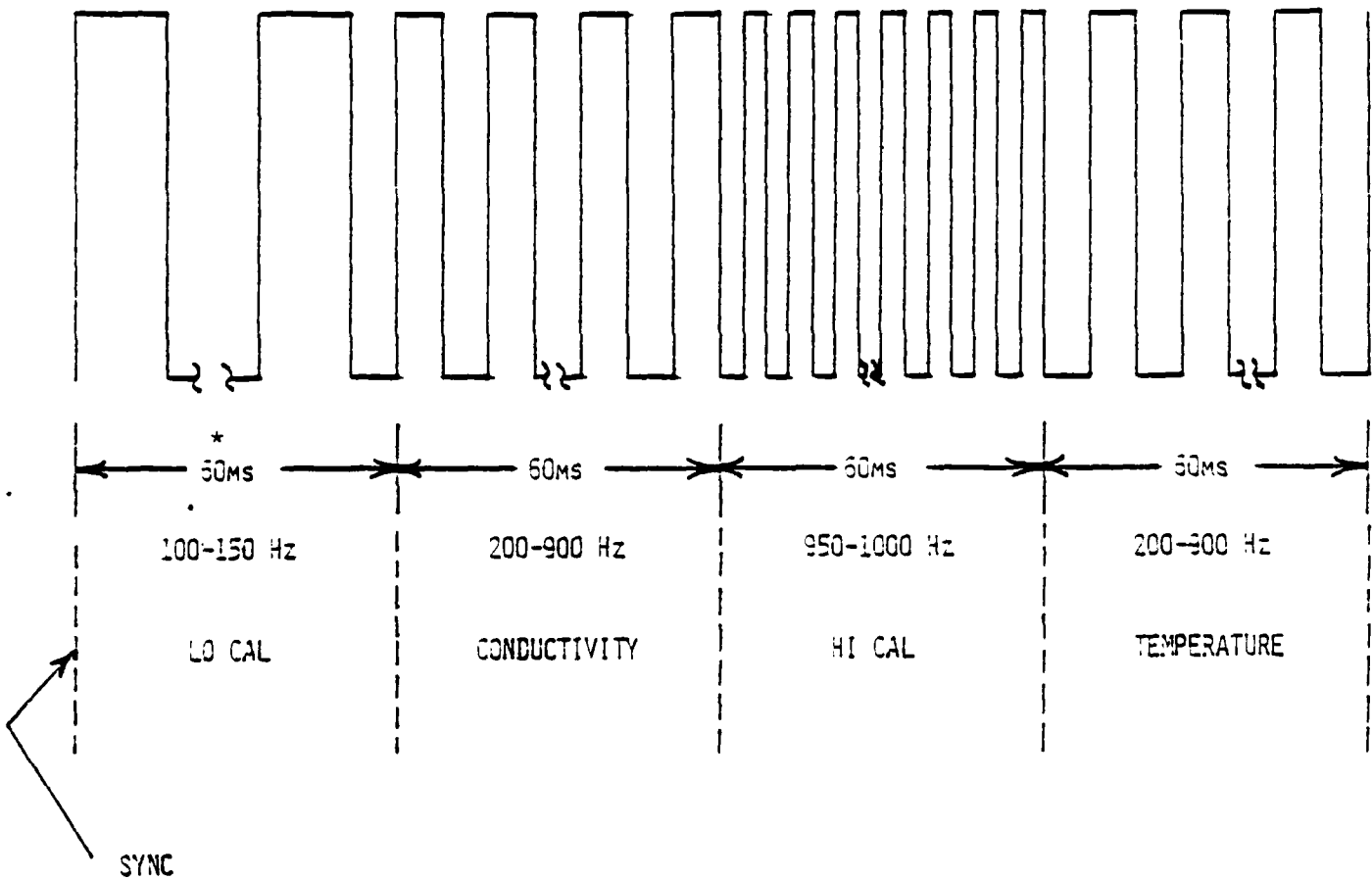

XCTD DATA TRANSMISSION FORMAT

* For lab testing this time, has been slowed down to approximately 1 sec. to allow time for measurement. Applicable only to simulated XCTD processor.

FIGURE 3.0-2

This provided for the analysis of the relative merits of cycle averaging and determined the minimum wait required after the beginning of each cycle to account for settling time. The frequency bandwidths shown are approximate and some overlapping may have to be accounted for in the processing as a price for thermistor and conductivity cell noninterchangeability. The channel widths are approximately 60 ms wide resulting in a data rate of approximately four measurement sets per second. The counter and the voltmeter serve temporarily as the XCTD receiver and processor. Therefore, in order to measure as many as ten cycles after a delay and provide enough time for the voltmeter or frequency counter to make a conversion, the channel width was expanded to approximately one second each. The XCTD circuit is continuously and asynchronously outputting the data in the order shown in Figure 3.0-2. The voltage across the 400 Ω resistor R_{LO} is sampled, amplified, and fed to the voltmeter while simultaneously being converted to a frequency followed by a pulse of width equal to a predetermined number of cycles of the frequency, and fed to the counter after a predetermined delay. The same process follows with the conductivity cell (or R_{δ} resistance decade), the 4 K Ω resistor R_{HI} and the thermistor (or R_T resistance decade). Upon a command from the operator the HP85 computer continuously addresses the counter and the voltmeter and looks for the Low Cal frequency. The frequency is determined from the pulse width knowing the cycle count (2, 4, 6, 8 or 10). Once found the frequency is stored for subsequent use. The conductivity channel is expected next, followed by the High Cal and Temperature channels. If these channels are not found in the correct order the computer deletes all previous channel information and begins another search for the Low Cal channel. All accepted frequencies are followed immediately by the storage of voltage data. Once the computer has received all four channels of data it proceeds with the processing of the data. Signal attenuation is shown graphically in Figure 3.0-3. The maximum frequency is approximately 1 kHz which is attenuated by 57 dB for 8500 ft. of wire. The output signal from the probe is approximately 12 VRMS. This results in a minimum signal at the surface of 0.017VRMS. At 100 Hz the surface signal amplitude is attenuated by approx. 18 dB and results in a 1.5 VRMS signal.

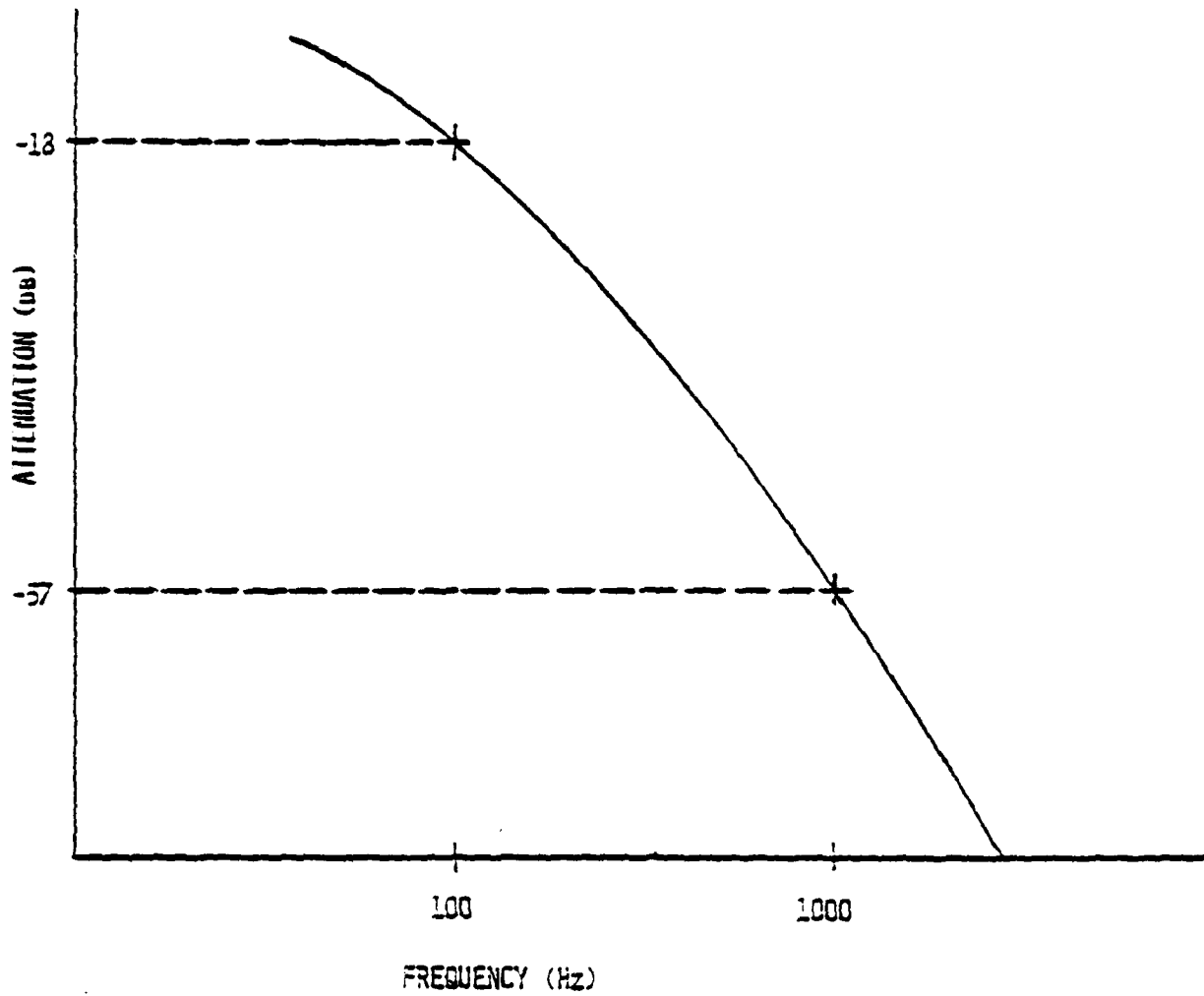

FOR 8500 FT #39:

a 100 Hz → -18dB ATTENUATION
a 1000 Hz → -57dB ATTENUATION } RANGE = 39dB

BT 2 CONDUCTOR WIRE SIGNAL ATTENUATION

FIGURE 3.0-3

3.3 Calibration and Test Requirements

In order for the XCTD probe to make an accurate measurement of conductivity and temperature the characteristics of both the conductivity cell and the thermistor must be determined. These characteristics are determined by actually measuring the cell's and thermistor's in-circuit response under known conditions of conductivity and temperature. Effectively this is determining the measured resistance of the cell and thermistor at three discrete values of conductivity and temperature, respectively. To date, conductivity and temperature calibrations, and consequently, actual measurement profiles have been taken with one of the sensors simulated with a resistance decade box. During Phase II both salinity and temperature will be changed simultaneously in a controlled bath during calibration and testing of deployable units. The required setting of R_T is known approximately from previous tests or manufacturer's data for the thermistor. The same holds true for R_δ knowing the approximate cell constant. Therefore, the calibration procedure, under program direction, involves the acquisition of extra temperature or conductivity data, ie. Low Cal, Conductivity, High Cal, Temperature, at three different levels. Once acquired, temperature (conductivity) can now be profiled by varying the temperature (conductivity) of the temperature (seawater) bath, while varying or holding constant the $R_\delta(R_T)$ decade box. During both the calibration and measurement phases, measurements are continuously received from the Neil Brown Standard. The accuracy of the Neil Brown Standard is $\pm 0.005^\circ\text{C}$ for temperature and ± 0.005 mmho/cm for conductivity. The measurements received during the calibration are stored by the computer and are incorporated in the calculations during the measure phase. The measurements received during the measure phase are used for comparison purposes only.

3.4 Data Processing and Software

The HP85 is the central component on the receiving end of the XCTD system in the lab configuration, and its functions are to:

- Manage calibrate and measure operations
- Input temperature and conductivity as measured by the Neil Brown Standard
- Input time interval data from the counter and convert to a frequency
- Input voltage data from the voltmeter
- Generate the circuit transfer function before each calibrate and measure cycle
- Calculate thermistor and conductivity cell sensitivities from calibration data
- Calculate actual conductivity and temperature based on measurement data and thermistor and conductivity cell sensitivities
- Provide a printout of:

Temperature and Conductivity as measured by the standard during calibration and in situ measurements

Voltage and frequencies as measured during calibration and in situ measurements

Resulting XCTD in situ temperature and Conductivity measurements

3.4.1 Initialization

A flow diagram of the software program is shown in Figure 3.0-3,A-D. The program begins with the initialization of the interfaces as required by the

INITIALIZATION

CALIBRATION

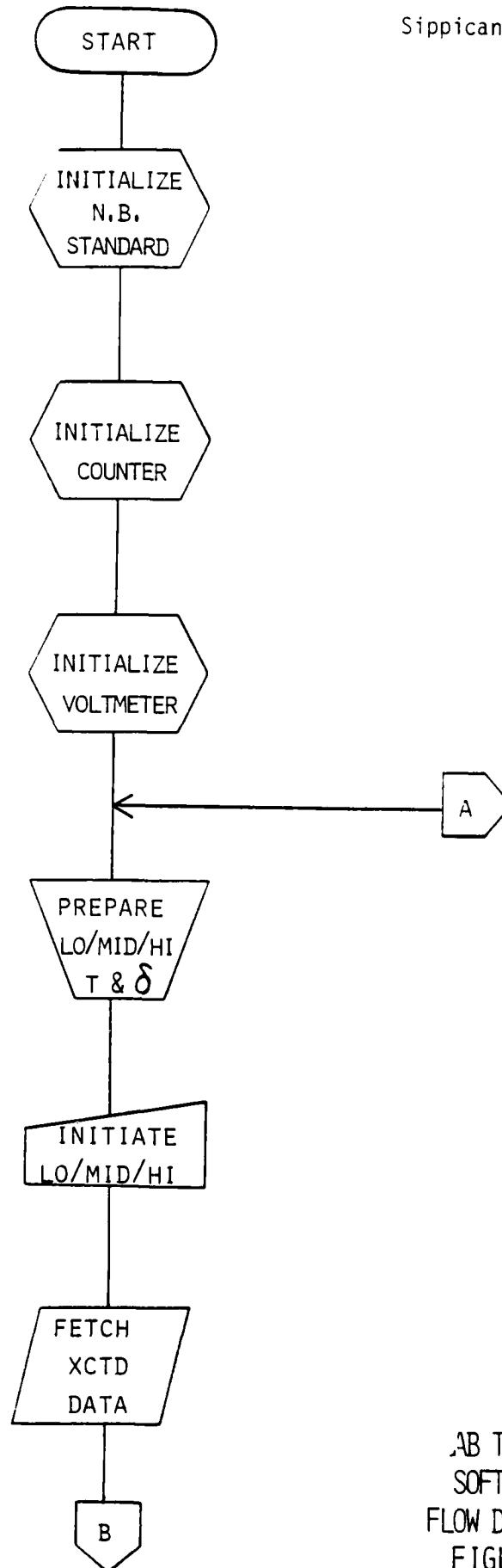

LAB TESTING
SOFTWARE
FLOW DIAGRAM
FIGURE 3.0-3A

PRE-LAUNCH

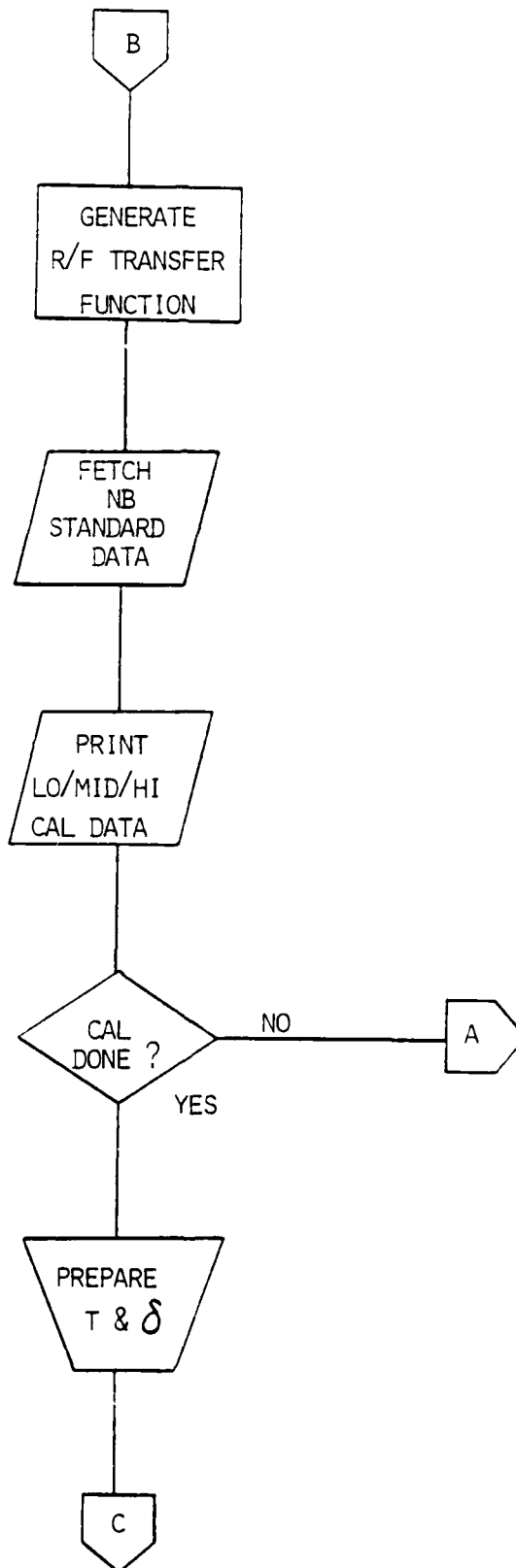

FIGURE 3.0-3B

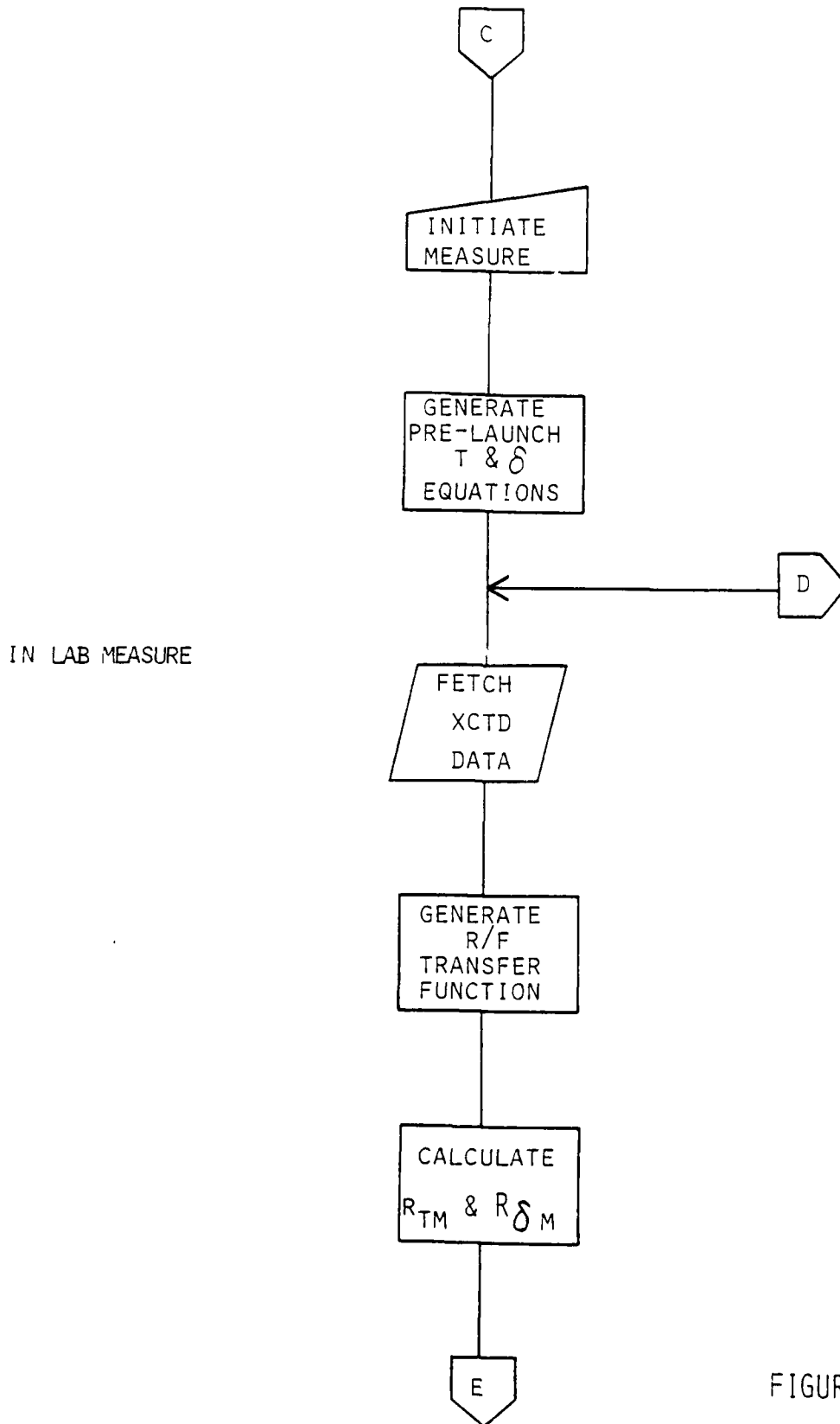

FIGURE 3.0-3C

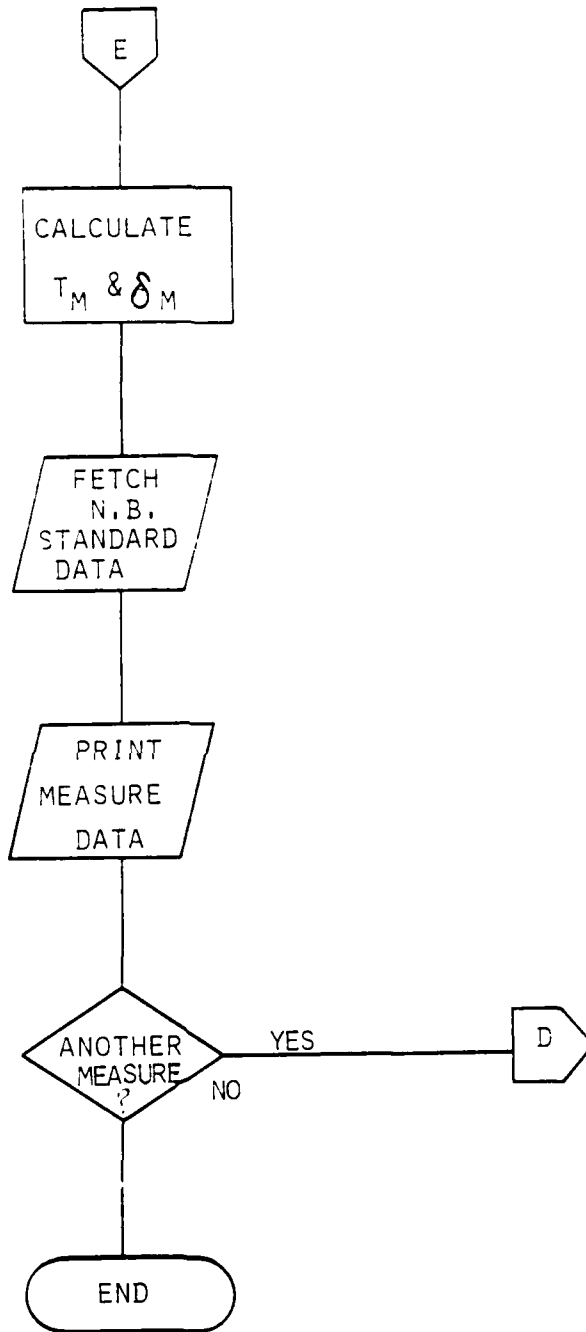

FIGURE 3.0-3D

HP85 and/or instruments. The Neil Brown Standard uses an RS-232 data link, which requires the setting of certain control bits. The counter requires trigger polarities, gate, and mode settings and the voltmeter requires scale and mode settings.

3.4.2 Calibration

Following the instrument initializations the program requests a low, middle, or high calibration run and the XCTD and Neil Brown Probes are immersed in the low/middle/high bath. If simultaneous temperature and conductivity calibrations are being made, no decade box is required. When ready, required calibration level is input to the computer and the computer inputs the XCTD data, followed immediately by the calculation of R vs F and R vs V circuit transfer functions as determined from the R_{HI} and R_{LO} resistors and their resulting frequencies and voltages. This is shown graphically in Figure 3.0-4 along with the circuit transfer function. For simplification only frequencies will be used in the following descriptions, but voltages can be directly substituted for the frequencies. The applicable variables used in Figure 6 are defined as follows:

R_{CH} , F_{RCH} ... Cal High resistor ($=4K\Omega$, $\pm 0.005\%$)
and resulting output frequency.

R_{CL} , F_{RCL} ... Cal Low resistor ($=400\Omega$, $\pm 0.005\%$)
and resulting output frequency

R, F Calculated resistance R as determined
from the measured frequency F

The circuit transfer function is derived for every calibration or measure cycle, thus compensating for any circuit variations such as amplifier gain, offset, drift, power supply fluctuation, etc. Next the program calculates

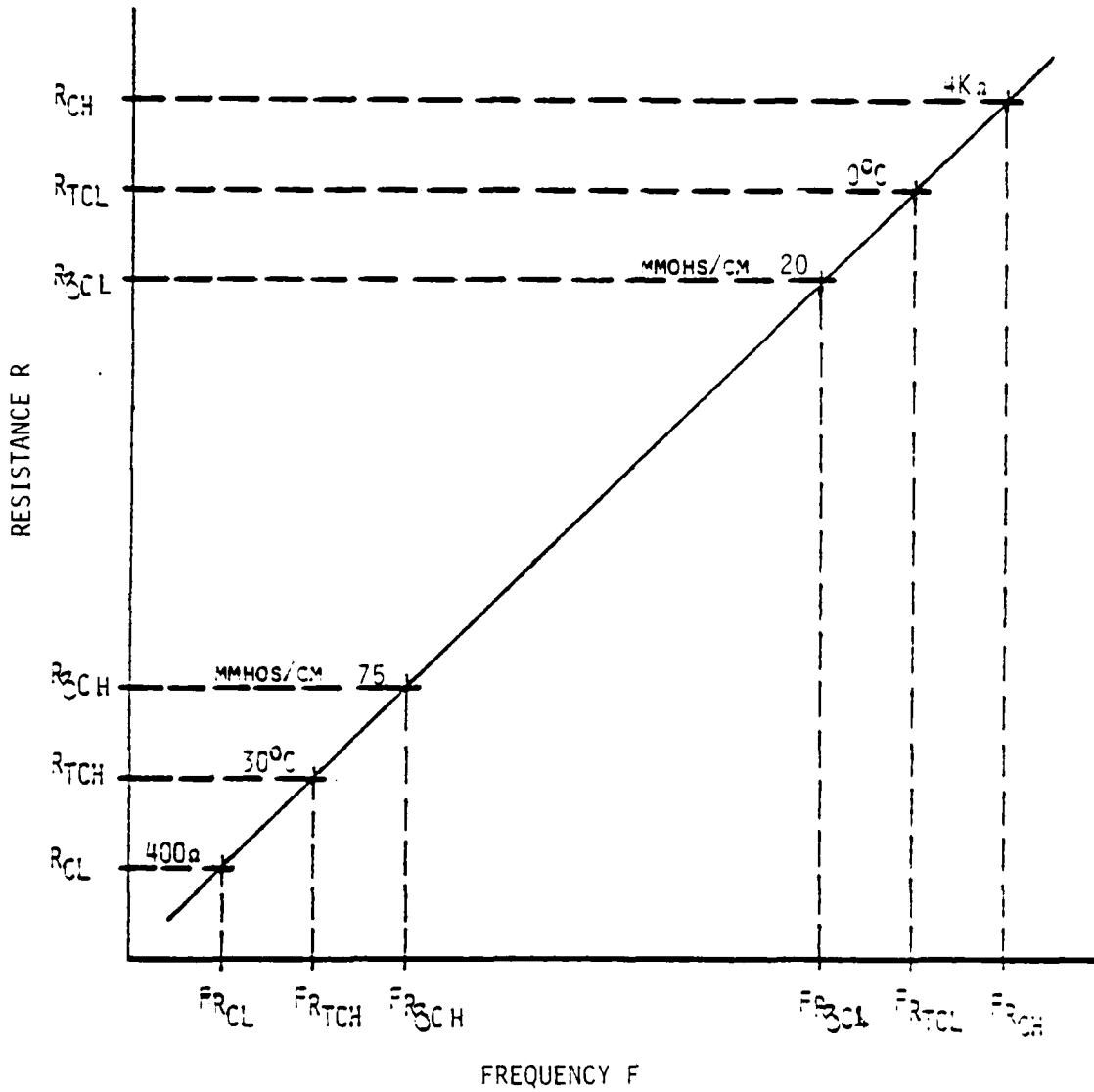

$$R = \frac{R_{CH} - R_{CL}}{F_{RCH} - F_{RCL}} (F - F_{RCH}) + R_{CH}$$

XCTD "R/F" LINE EQUATION

FIGURE 3.0-4

the thermistor and conductivity cell resistances using the transfer function and the measured temperature and conductivity frequencies. The process is repeated for the remaining two calibration levels. This now introduces the remaining variables in Figure 6 as:

F_{RTCH} , R_{TCH} ... Frequency of temperature channel at
Cal High and resulting calculated resistance

F_{RTCS} , R_{TCS} ... At Cal Middle

F_{RTCL} , R_{TCL} ... At Cal Low

$F_{R\delta CH}$, $R_{\delta CH}$... Frequency of conductivity channel at Cal High
and resulting calculated resistance

$F_{R\delta CS}$, $R_{\delta CS}$... At Cal Middle

$F_{R\delta CL}$, $R_{\delta CL}$... At Cal Low

As a result of all the foregoing measurements each individual XCTD probe has now been "characterized" and with the thermistor and conductivity cell sensitivities assumed stable over time the following parameters are assumed never to change:

T_{CH} , R_{TCH}

T_{CS} , R_{TCS}

T_{CL} , R_{TCL}

δ_{CH} , $R_{\delta CH}$

δ_{CS} , $R_{\delta CS}$ •

δ_{CL} , $R_{\delta CL}$

The final process at each calibration level is a printout of actual temperatures and conductivities and corresponding voltages and frequencies. A sample calibration phase printout is presented in Figure 3.0-5. In summary, the calibration phase of the operation is to determine the temperature and corresponding calculated resistance and the conductivity and the corresponding calculated resistance at three different calibration levels. These parameters are stored permanently as probe characterizing data.

3.4.3 Pre-Lab Measurement

After the calibration phase the program is ready to initiate a measurement. Referring again to the flow diagram in Figure 3.0-3 the original calibration (or characterizing) data is used in the generation of pre-launch equations. This is shown graphically in Figure 3.0-6 the pre-launch equations are curve fitting equations, which use the probe characterizing data to generate functions of temperature and conductivity in terms of resistance. These equations are fixed for the life of the probe. Therefore, after the generation of the two equations the XCTD is ready to make measurements. At this point the variable temperature and/or conductivity bath(s) are prepared. If only temperature (conductivity) is to be profiled, the R_T (R_γ) decade box must be used to simulate the conductivity cell (thermistor).

3.4.4 Lab Measurement

A measurement begins on command from the operator. If the R_T (R_γ) decade box is used, the Low, Mid, and High Cal temperature (conductivity) will

*** LOW CAL ***

*** MID CAL ***

*** HIGH CAL ***

NEIL BROWN T AN 6:

Ta = 22.9219 *
Sa = 21.2368

NEIL BROWN T AN 6:

Ta = 21.9628 *
Sa = 20.7028

NEIL BROWN T AN 6:

Ta = 21.9599 *
Sa = 20.2799

NOTE FREQUENCIES:

F1000 = 949.169
F1001 = 109.711
F1002 = 524.849 *
F1003 = 421.559

NOTE FREQUENCIES:

F1000 = 981.749
F1001 = 119.549
F1002 = 519.389 *
F1003 = 199.499

NOTE FREQUENCIES:

F1000 = 989.949
F1001 = 114.849
F1002 = 104.919 *
F1003 = 199.399

NOTE VOLTAGES:

V1000 = 84.529
V1001 = 88.319
V1002 = 82.559 *
V1003 = 81.384

NOTE VOLTAGES:

V1000 = 84.599
V1001 = 88.369
V1002 = 81.359 *
V1003 = 88.749

NOTE VOLTAGES:

V1000 = 84.739
V1001 = 88.349
V1002 = 88.594 *
V1003 = 88.419

* IN THIS EXAMPLE ONLY CONDUCTIVITY (σ) IS BEING VARIED, TEMPERATURE (T) DOES NOT APPLY

CALIBRATION PHASE PRINTOUT
(CONDUCTIVITY)

FIGURE 3.0-5

AT PRELAUNCH

PRELAUNCH EQUATIONS ARE GENERATED BASED ON
PROBE CAL-DATA:

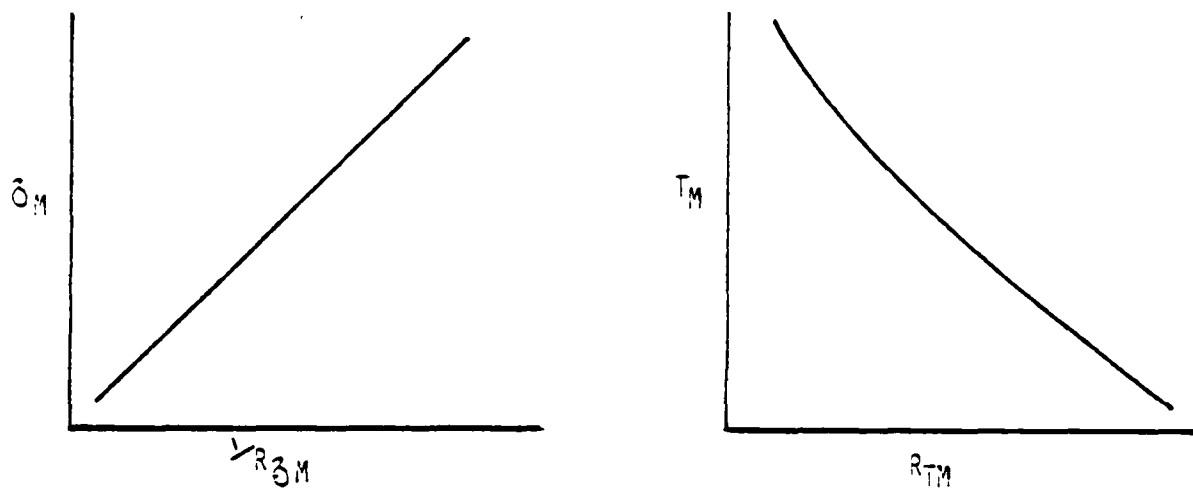
CONDUCTIVITY EQUATION:

$$\delta_M = F(\delta_{CH}, R_{\delta CH}), (\delta_{CS}, R_{\delta CS}), (\delta_{CL}, R_{\delta CL}), R_{\delta M}$$

TEMPERATURE EQUATION:

$$T_M = F(T_{CH}, R_{TCH}), (T_{CS}, R_{TCS}), (T_{CL}, R_{TCL}), R_{T_M}$$

PRELAUNCH EQUATIONS

FIGURE 3.0-6

have to be input manually to satisfy the software requirements, while conductivity (temperature) data is received from the Neil Brown Standard. If simultaneous calibrations of temperature and conductivity were made, the measurements can be performed in the same manner and without the use of a decade box. The lab measurement begins with received data from the XCTD, followed immediately by the generation of the circuit transfer function using F_{RCH} and F_{RCL} measurements just as during calibration. Once the circuit transfer function is known the thermistor (or R_T) and conductivity cell (or R_δ) resistances are calculated as R_{TM} and $R_{\delta M}$, respectively. Next, the pre-launch equations are used to calculate the temperature and conductivity T_M and δ_M , respectively. Finally, the data from the Neil Brown Standard is received and a printout of the actual and measured temperatures and conductivities along with frequencies and voltages is printed. A sample measure printout is presented in Figure 3.0-7. This is for lab measurements only when conductivity and temperature errors are being measured.

3.5 Summary

Figure 3.0-8 is a block diagram summarizing the whole calibration and measurement process. The first step is to generate three discrete temperatures and conductivities and calculate their respective resistances via the R/F (resistance to frequency) transfer function, which is generated at every cal point. These six data pairs characterize the probe and are used to generate the pre-launch equations. The pre-launch equations are curve fitting equations, although to date a linear equation has been used for conductivity with good results. This equation utilizes only High and Low conductivity calibration data. Following pre-launch the probe is ready for the lab measurements and as shown in the block diagram, the transfer function is first calculated for each measurement followed immediately by the determination of the temperature and conductivity sensor's resistances. Finally, utilizing the pre-launch equations the temperature and conductivity is calculated.

*** MEASURE ***

NEIL BROWN T AND S:

Ta = 22.8270 *
Sa = 21.3000

XCID FREQUENCIES:

Frchm = 949.118
Frc1m = 106.713 *
Frtm = 524.838 *
Frdm = 423.442

XCID VOLTAGES:

Vrchm = 04.526
Vrc1m = 00.319
Vrtm = 02.393 *
Vrdm = 01.883

FREQUENCY BASED RESULTS:

Tmf = 2.003
Smf = 21.299

VOLTAGE BASED RESULTS:

Tmv = 2.003
Smv = 21.302

*** MEASURE ***

NEIL BROWN T AND S:

Ta = 22.8445 *
Sa = 20.6220

XCID FREQUENCIES:

Frchm = 956.434
Frc1m = 107.536 *
Frtm = 528.913 *
Frdm = 323.825

XCID VOLTAGES:

Vrchm = 04.563
Vrc1m = 00.323
Vrtm = 02.413 *
Vrdm = 01.383

FREQUENCY BASED RESULTS:

Tmf = 2.002
Smf = 28.534

VOLTAGE BASED RESULTS:

Tmv = 2.002
Smv = 28.610

*** MEASURE ***

NEIL BROWN T AND S:

Ta = 22.8870 *
Sa = 35.9410

XCID FREQUENCIES:

Frchm = 961.003
Frc1m = 108.049 *
Frtm = 531.288 *
Frdm = 253.242

XCID VOLTAGES:

Vrchm = 04.585
Vrc1m = 00.325 *
Vrtm = 02.425 *
Vrdm = 01.081

FREQUENCY BASED RESULTS:

Tmf = 2.008
Smf = 35.761

VOLTAGE BASED RESULTS:

Tmv = 2.001
Smv = 35.934

* IN THIS EXAMPLE ONLY CONDUCTIVITY (σ) IS BEING VARIED, TEMP (T) DOES NOT APPLY

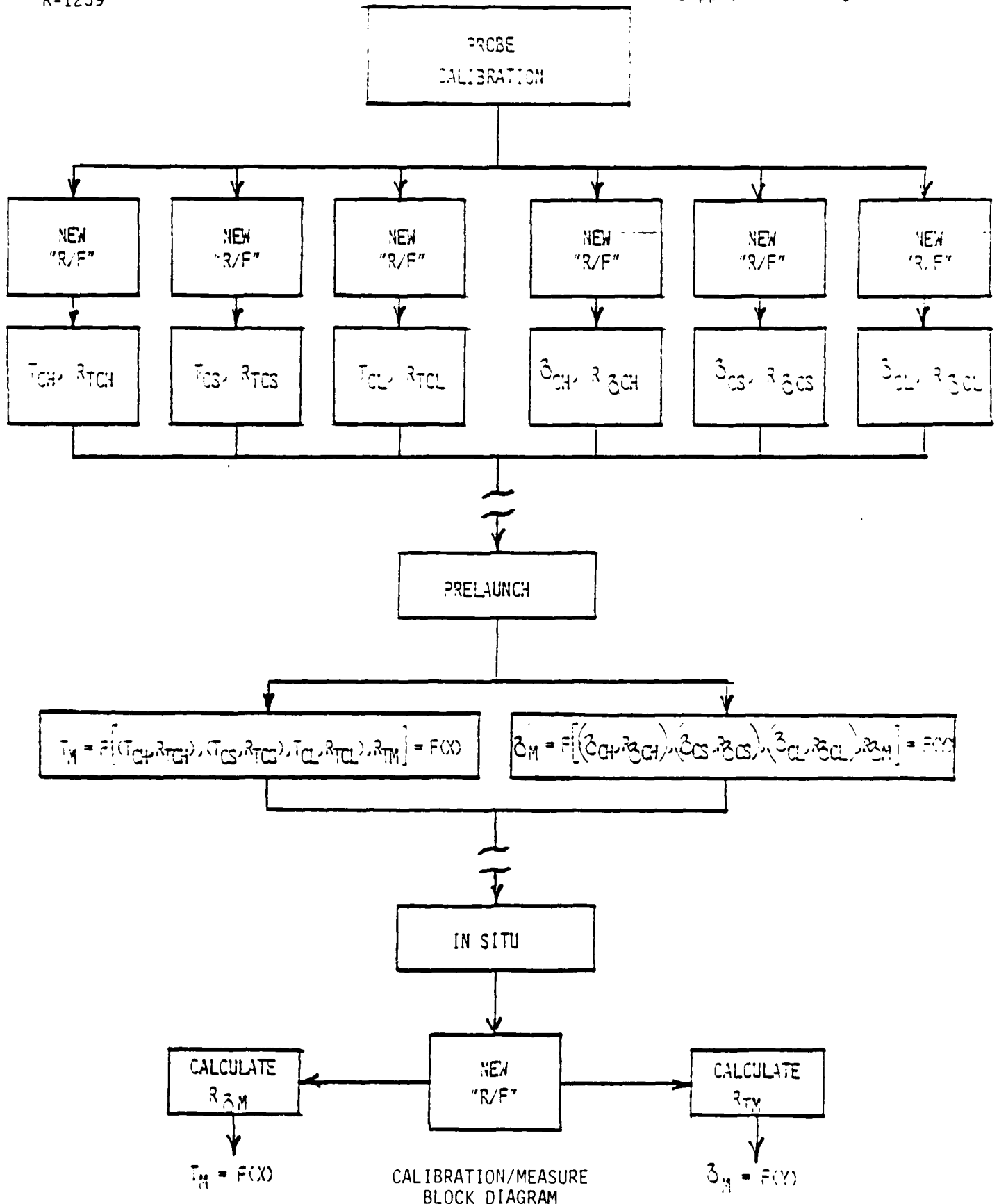

FIGURE 3.0-8

4.0 SYSTEM ERROR ALLOCATIONS

As mentioned previously the errors have been proportioned to three areas as follows:

1. Conductivity/Temperature
2. Probe Processing Electronics
3. MK 9 Data Recorder

Each category is allowed a maximum error of 0.01°C and 0.01 mmhos/cm.

4.1 Sensor Error Contribution

Sensor error contributions have been analyzed separately in terms of accuracy and stability. Each show the ability to meet or exceed the maximum allowable error.

4.1.1 Conductivity Sensor Error Contribution

The conductivity sensor or cell is a linear device with a measured cell constant of approximately 37.5/CM. The cell is a four electrode device, therefore, its stability is influenced only by the internal volume and not the electrodes. The volume can be changed in only two ways: Buildup of film within the walls of the cell and changes in volume due to expansion or contraction of the cell due to temperature changes. The coefficient of expansion is 32×10^{-7} in/in°C. Therefore cell constant changes which are per

$$K = L/A$$

for this type of cell are equivalent to that which produces approximately a 0.001 mmho error over 60°C of temperature change. Buildup of film within the cell would not occur since the cell is intended to be used only once and no contact with fluids are made following calibration at the factory until deployment.

4.1.2 Temperature Sensor Error Contribution

The temperature sensor is a glass encapsulated thermistor whose long term stability is dependent on its operating current and environmental exposure. The operating current is very small (approximately 43 microamperes) and is of course zero while in storage. Therefore, how well the thermistor is sealed in the glass over a long period will have the most influence on the thermistor's long term stability. During the years 1974 to 1975 the National Bureau of Standards tested 405 thermistors from 6 manufacturers. The bead in glass thermistors, which is the type selected for the XCTD application, exhibited only a 0.00042°C per 100 days average drift in a constant 60°C temperature bath. This is equivalent to a temperature drift of 0.003°C in two years. Specifically, the Thermometrics thermistors showed a 0.00020°C per 100 days temperature drift, which is equivalent to approximately 0.001°C in two years. Therefore, the 0.01°C allowable error will be attributable mostly to linearizing errors. Linearizing is performed in the MK 9 software using the three temperature calibration points and is accurate to better than 0.01°C over the temperature range. Self heating due to operating current is also well below the allotted sensor accuracy as described in Section 7.0.

4.2 Probe Processing Electronics

Overall circuit accuracy, independent of the thermistor and conductivity cell was determined. The test was performed both immediately and using the same characterization data, three days after calibration. Both decade boxes were used to simulate the sensors during the calibration and measure phases. The conductivity decade was varied according to the following relationship:

$$R_s = \frac{1}{s} (K) \times 1000$$

Where $K = 35.7 \text{ cm}^{-1}$ is the cell constant, S is equivalent conductivity in mmhos/cm and R_S is resistance in ohms. The temperature decade was varied during calibration but held constant during measure to investigate the magnitude of change due to varying conductivity. A three point calibration was performed for both temperature and conductivity to satisfy software requirements but only high and low cal data was used in the conductivity pre-launch equation. All results were based on output voltage measurements rather than frequency due to the relative non-linearity of the Voltage to Frequency Converter. Table I shows the resulting equivalent conductivity errors over a range of 20 to 75 mmhos/cm. The largest error occurred at 65 mmhos/cm and is 0.006 mmhos/cm. The equivalent temperature variation over the whole range of conductivity was 0.003°C. Three days later the same test was run using the same characterizing data, i.e., the calibration phase was not repeated. These results are also presented in Table I.

4.3 MK 9 DATA RECORDER XCTD INTERFACE

The XCTD interface in the MK 9 Data Recorder will be allotted one third of the overall system accuracy. The inaccuracies will be directly dependent on the inaccuracies of the system clock and jitter in the detector circuitry in the analog receiver section.

TABLE I
OVERALL SYSTEM ACCURACY

$\frac{T}{^{\circ}\text{C}}$	$\frac{R_T}{\Omega}$	$\frac{\delta}{\text{mmho/cm}}$	$\frac{R\delta}{\Omega}$	$\frac{T_M}{^{\circ}\text{C}}$	$\frac{\delta M_1}{\text{mmho/cm}}$	$\frac{\delta E_1}{\text{mmho/cm}}$	$\frac{\delta M_2}{\text{mmho/cm}}$	$\frac{\delta E_2}{\text{mmho/cm}}$
2.0035	217.0	20.000	1785.0					
15.0005	1243.0	50.000	714.0	Calibration Phase. T is from measured data.				
29.9895	686.0	75.000	476.0					
2.0035	2174.0	20.000	1785.0	2.004	20.000	0.000	20.000	0.000
		25.000	1428.0	2.003	25.000	0.000	24.998	-0.002
		30.000	1190.0	2.003	30.001	0.001	29.999	-0.001
		35.000	1020.0	2.002	35.001	0.001	34.999	-0.001
		40.000	892.5	2.002	40.000	0.000	40.001	-0.001
		45.000	793.3	2.002	45.002	0.002	44.999	-0.001
		50.000	714.0	2.002	50.003	0.003	50.000	0.000
		55.000	649.1	2.002	55.001	0.001	54.998	-0.002
		60.000	595.0	2.002	60.001	0.001	60.000	0.000
		65.000	549.2	2.002	65.006	0.006	64.996	-0.004
		70.000	510.0	2.001	70.004	0.004	69.998	-0.002
		75.000	476.0	2.001	75.003	0.003	75.002	0.002

T... Equivalent temperature in °C as obtained from typical thermistor sensitivity data (decade box set at 2174 ohms during measure phase to represent 2.0035°C).

R_Tdecade resistance simulating T

δequivalent conductivity at $R\delta$

$R\delta$decade resistance simulating δ

T_Mresulting equivalent temperature

$\delta M_1, \delta E_1$... resulting equivalent conductivity and error, day 1.

$\delta M_2, \delta E_2$... resulting equivalent conductivity and error, day 4.

5.0 CIRCUIT STABILITY

Circuit stability was determined by independently varying amplifier gain and offset after the initial calibration phase. Resistance decade boxes were used in place of the sensors as in Section 3. Table II shows the results of varying the gain from the nominal of 15 to 10 and then to 20. The top of Table II shows the absolute readings at three different conductivities and temperatures. Circuit calibration was performed at a gain of 15 in this case, followed by measurements at the three different gain settings. The middle of Table II shows the absolute error as a result of the gain variation from nominal. Finally, the bottom of Table II shows the deviation of conductivity and temperature as a result of varying the gain from its nominal value. The results show that with only two exceptions the errors due to a gain change were less than 0.01 mmhos/cm and 0.01°C. A similar test was performed to determine variation with circuit offset. Table III shows the results in a format similar to that used in Table II. Here, calibration was performed at an offset of 0.0 volts and measurements were made at an adjusted offset of 0.30 volts and -0.30 volts. The results show that with only a few exceptions the error is less than 0.01 mmhos/cm and 0.01°C. Considering that the offset and gain were varied approximately 30 times greater than would be expected over the temperature range these errors are very conservative.

TABLE II
CIRCUIT GAIN STABILITY

<u>GAIN</u>	<u>$\delta_L=20$</u>	<u>$\delta_S=45$</u>	<u>$\delta_H=65$</u>	<u>$T_L=2.004$</u>	<u>$T_S=15.001$</u>	<u>$T_H=29.989$</u>
10	19.996	44.984	65.019	2.005	15.000	29.932
15	19.999	44.987	64.990	2.003	14.999	29.987
20	19.996	44.981	64.981	1.998	14.981	29.986

ERROR

10	0.004	0.016	-0.019	-0.001	0.001	0.007
15	0.001	0.013	0.010	0.001	0.002	0.002
20	0.004	0.019	0.019	0.006	0.020	0.003

DEVIATION

10	-0.003	0.003	-0.029	-0.002	-0.001	0.005
15	0	0	0	0	0	0
20	-0.003	0.006	0.009	0.005	0.018	0.001

δ is in mmhos/cm

T is in °C

TABLE III

CIRCUIT OFFSET STABILITY

<u>OFFSET</u>	<u>$\delta_L=20$</u>	<u>$\delta_S=45$</u>	<u>$\delta_M=65$</u>	<u>$T_L=2.004$</u>	<u>$T_S=15.001$</u>	<u>$T_H=29.989$</u>
0.30	19.998	44.995	65.005	1.998	15.000	29.991
0	20.001	44.991	65.002	2.004	15.001	29.987
-0.30	19.998	44.978	64.972	2.003	14.999	29.978

ERROR

0.30	0.002	0.005	-0.005	0.006	0.0012	-0.002
0	-0.001	0.009	-0.002	0.000	0.000	0.002
-0.30	0.002	0.022	0.028	0.001	0.002	0.011

DEVIATION

0.030	0.003	-0.004	-0.003	0.006	0.001	-0.004
0	0	0	0	0	0	0
-0.30	0.003	0.013	0.03	0.001	0.002	0.009

δ is in mmhos/cm

T is in °C

6.0 SYSTEM MEASUREMENT ACCURACY

During the course of the XCTD circuit development a number of both temperature and conductivity profiles were made to determine the relative accuracy of each. At no time were conductivity and temperature simultaneously profiled but a reasonable approximation was made by simulating one of the sensors with a resistance decade.

6.1 Conductivity

Using the laboratory procedures described in Section 3 measurements of temperature and conductivity were individually made and accuracies based on the Neil Brown Standard were determined. Table IV shows the results of a measurement made in one time period, i.e., immediately following the calibration phase. All the measurements were made in approximately a two hour period. Temperature was simulated with a decade box while conductivity was a real measurement. During the conductivity profile the decade box resistance was held constant at that resistance representing 2.000 C. Two outputs, frequency and voltage, are listed and the conductivity accuracies as a result of each are also included. The conductivity range was from approximately 20 to 75 mmhos/cm.

6.2 Temperature

A temperature profile was generated over a temperature range of approximately 2°C to 30°C. Calibration data was simultaneously taken during the profiling procedure at low, mid (15°C), and high temperature. A decade box substituted for conductivity during the procedure and was held constant during the entire profile. Table V lists the results of the test.

TABLE IV

CONDUCTIVITY ACCURACY TEST

<u>δ_{nb}</u>	<u>δ_{mv}</u>	<u>δ_{mf}</u>	<u>E_v</u>	<u>E_f</u>
20.912	20.913	20.920	-.001	-.008
27.576	27.581	27.596	-.005	-.020
34.008	34.016	34.017	-.008	-.009
40.244	40.254	40.259	-.010	-.015
46.295	46.300	46.274	-.005	-.021
52.150	52.159	52.148	-.009	+.002
57.850	57.862	57.840	-.012	+.010
63.457	63.470	63.452	-.013	+.005
68.759	68.771	68.750	-.012	+.009

δ_{nb}Conductivity as measured by the Neil Brown Standard.
Units are in mmhos/cm.

δ_{mv}Conductivity as measured by the XCTD as per voltage
measurements. Units are in mmhos/cm.

δ_{mf}Conductivity as measured by the XCTD as per frequency
measurements. Units are in mmhos/cm.

E_v Resulting error per voltage measurements in mmhos/cm.

E_f Resulting error per frequency measurements in mmhos/cm.

TABLE V
TEMPERATURE ACCURACY TEST

T_{nb}	T_{mv}	T_f	E_v	E_f
0.0045	-0.001	-0.002	0.006	0.007
2.0105	2.006	2.007	0.005	0.004
4.0025	3.999	4.001	0.004	0.002
6.0020	5.997	5.997	0.005	0.005
8.0045	8.001	8.002	0.004	0.003
10.0030	9.996	9.999	0.007	0.004
12.0045	12.002	12.004	0.003	0.001
14.0040	14.000	14.000	0.004	0.004
16.0030	15.997	15.999	0.006	0.004
18.0025	17.998	17.999	0.005	0.004
20.0010	19.996	19.997	0.005	0.004
22.0010	21.997	21.998	0.004	0.003
24.0000	23.995	23.995	0.005	0.005
25.9980	25.993	25.994	0.005	0.004
27.9955	27.991	27.993	0.005	0.003
29.9930	29.989	29.989	0.004	0.004

T_{nb}Temperature as measured by the Neil Brown Standard.
Units are in °C.

T_{mv}Temperature as measured by the XCTD as per voltage
measurements. Units are in °C.

T_f Temperature as measured by the XCTD as per frequency
measurements. Units are in °C.

E_v Resulting error per voltage measurements in °C.

E_f Resulting error per frequency measurements in °C.

7.0 THERMISTOR TYPE

Two thermistors, a Fenwall type GB31M2 and a Thermometrics type P20BA102M, were used in the cab tests. Both thermistors are glass encapsulated noninterchangeable devices with tolerances specified at $\pm 20\%$ from the nominal resistance of 1K at 25°C. The Thermometrics thermistor was used in the test which produced the data shown in Table V, page 6-3. A linearization equation and three point calibration is used to obtain the specified accuracies. The time constant, which is the time required for the thermistor to change its own temperature 63% of the way from its original value to the value impressed upon it in a step change, was experimentally found to be 200 msec for the Fenwall type and 20 msec for the Thermometrics type. Figure 7.0-1 shows a scope trace of the response of the Thermometrics thermistor. The thermistor was taken from air temperature, the T_{High} reference line on the trace, and plunged into a temperature bath at 2.30°C, the T_{Low} reference line. The $T_{63\%}$ line is the 63% point mentioned above. The stability of the thermistors is insured by the glass encapsulation as described in Section 4.1.2. Both thermistors meet the stability requirements, and with the smaller time constant, the thermometrics thermistor also meets the required speed. A time constant of 20 msec means that in 5 time constants or approximately 100 msec, a step change in temperature is fully sensed by the thermistor.

The self heating of the thermistors were experimentally found to be approximately .002°C for the Fenwall type and .005°C for the thermometrics type. The above values, which refer to worst case conditions (lowest temperature and highest resistance), are below the allotted sensor accuracy. The current through the thermistor, approximately 43 μ A, is relatively small. The typical amount of power across the thermistor will be approximately 2 μ W and around that power range the self heating for the thermometrics thermistor is approximately .002°C. The Fenwall thermistor, which has a diameter of .060," and the Thermometrics thermistor, with a diameter of .020" will both be tested more extensively for accuracy and overall applicability in Phase II.

R-1259

Sippican Ocean Systems, Inc.

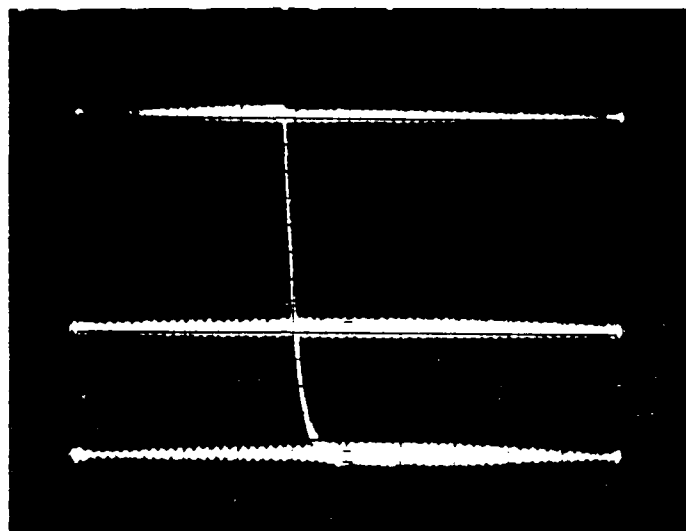

THERMISTOR TIME RESPONSE

FIGURE 7.0-1

8.0 CONDUCTIVITY CELL

The conductivity cell is of the four electrode type utilizing a Pyrex glass tube and platinized platinum electrodes. The cell configuration as advised by Neil Brown of Neil Brown Instruments, Inc. is pictured in Figure 8.0-1.

8.1 Configuration

The pyrex glass tube is approximately 8 inches in length with an I.D. of 0.157 inches and an O.D. of 0.24 inches. Inside the tube at its midpoint is a current electrode C1 and a voltage electrode V1. The remaining current electrode C2 and voltage electrode V2 are outside the cell. They will consist of wires within a protected flooded chamber within the probe body. The cell will reside at the center of the probe along its axis surrounded by the wire spool and electronics. During deployment water will enter the cell through an opening in the zinc nose and exit at the tail with the dereeling wire.

8.2 Operation

A schematic representation of the conductivity cell is shown in Figure 8.0-2. The cell functions as a four terminal resistor where a constant amplitude current AC square wave is applied to C1 and C2. The polarization impedances Z2 and Z4, which are a result of chemical reactions as the electrodes have no effect on the measurements since the voltage terminals are connected to a high impedance device. Similarly Z1 and Z3 have no effect since they are not part of the measurement circuit. Impedances R1 and R2 are the effective resistances of the seawater between the current electrodes and the voltage electrodes and are also not part of the measurement circuit. Therefore, this four electrode configuration is capable of accurately measuring the resistance of the seawater $R\delta$ independent of any unwanted series resistances.

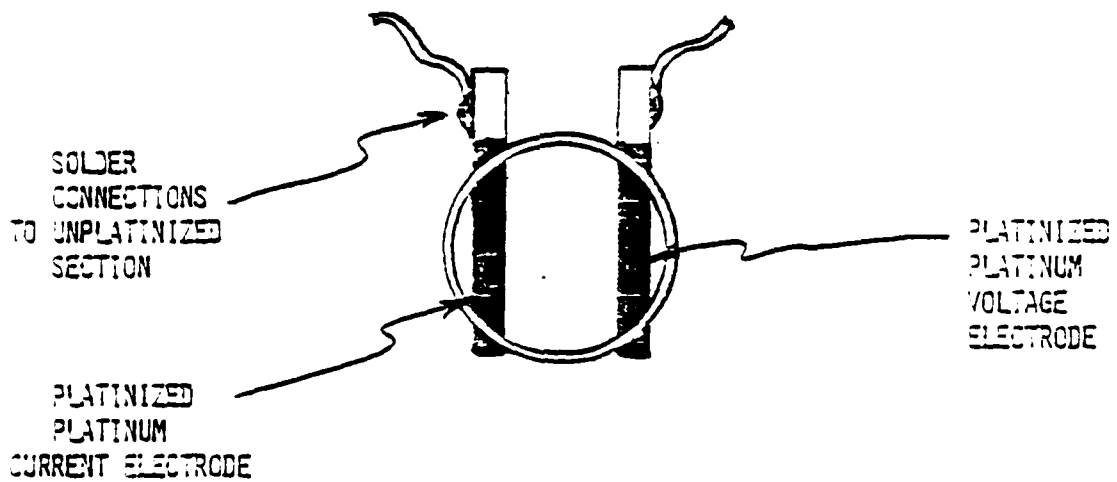
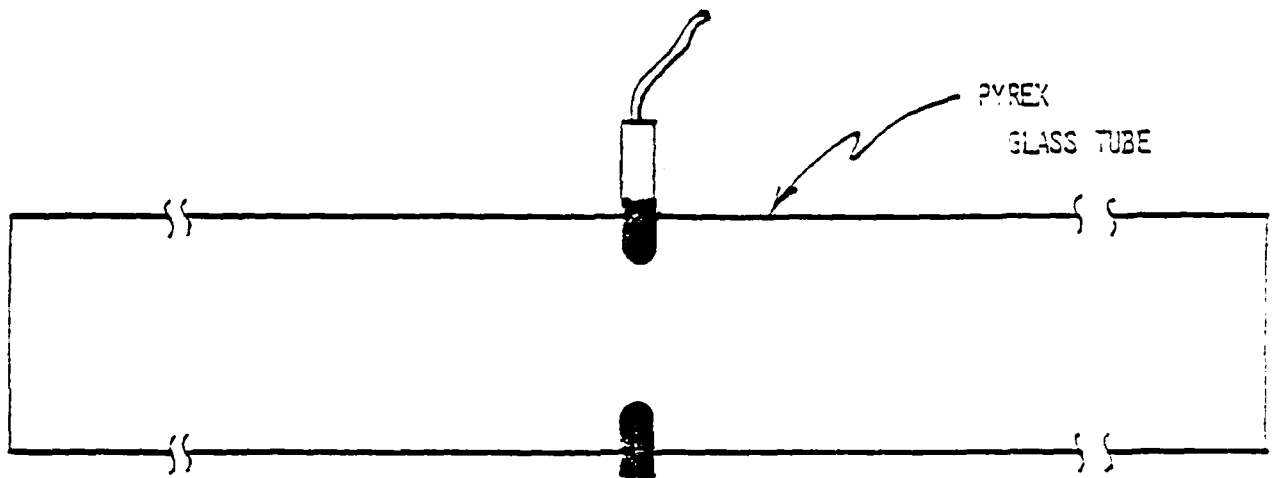

XCED CONDUCTIVITY CELL

FIGURE 8.0-1

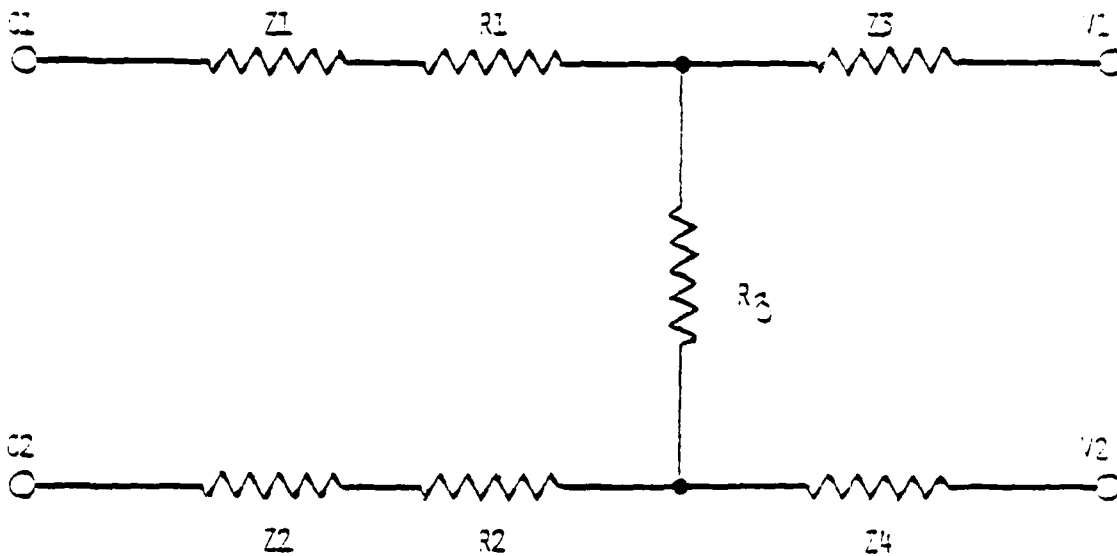

C1, C2... CURRENT ELECTRODES
 V1, V2... VOLTAGE ELECTRODES

Z1-Z4... POLARIZATION IMPEDANCES
 R1, R2... RESISTANCE-CURRENT ELECTRODE
 TO THAT POINT IN SEAWATER
 WHERE VOLTAGE IS MEASURED

R3... RESISTANCE CONDUCTIVITY CELL

XCTD CONDUCTIVITY CELL
MODEL

(4 ELECTRODE CONFIGURATION)

FIGURE 8.0-2

8.3 Electrode Platinization

The electrodes used in the conductivity cell are made of solid platinum. Platinum is a noble metal, and therefore, is ideal in a saltwater environment, but its cost is very high and warrants efficient utilization. Electrodes also require a large surface area to be effective in passing an AC signal with the minimum of loss. This is equivalent to a large effective series capacitance in series with the seawater resistance. Therefore, in order to increase surface area without adding material, the electrodes are platinized using a solution of 0.3% platinum chloride and 0.025% lead acetate in water. This creates a coating of platinum black which is extremely porous and increases the effective surface area of the electrodes. The electrodes are immersed in the platinizing solution and a small DC current is allowed to flow alternately between them at fifteen to twenty second intervals. Alternatively, both electrodes can be platinized simultaneously without current reversal by immersing both electrodes in the solution with a third electrode, which is made of stainless steel, nickel, or platinum. The third electrode would be the positive terminal. The platinizing continues until a uniform black matte finish appears and usually takes just a few minutes depending on the current density.

9.0 REMAINING DESIGN AREAS

There are two subsystem design functions that must be addressed. These are probe characterization or calibration data storage and custom LSI technology conversion of the probe electronics.

9.1 Calibration Data Storage

All XCTD probes are characterized with 6 pairs of calibration data. These are comprised of three pairs of temperature vs. frequency and three pairs of conductivity vs. frequency data. This data can be stored on cassette tape, which would be packaged one in each case of 12 probes. The tape would contain not only the calibration data but would provide the storage medium for the measured data. Another approach would be to use a bar code, which would be printed on each probe canister and provide an "intelligent" launcher or launcher modification kit, which would automatically read calibration data prior to launching of the probe. Another approach is an expendable prom or magnetic card which could be implemented in the MK9 processor. One prom or card would be supplied with each case of XCTD probes. For the present, system calibration data will be entered via the HP85 keyboard by the operator just prior to launching of the XCTD probe. The calibration data will be supplied with each probe.

9.2 Custom LSI Integrated Circuit

The XCTD circuit can be converted to a single custom integrated circuit. The circuit can be broken down into a number of functions, i.e., basic timing, multiplexing, voltage to frequency conversion, etc., all of which can be functionally incorporated on a single wafer containing analog and digital circuitry. The larger timing capacitors would be external to the custom I.C. In large quantities customizing of the circuit would reduce costs both in hardware and in assembly and test.

10.0 ALTERNATIVE APPROACHES

Sippican has considered various alternative approaches to the conductivity measurement problem. These approaches have been attempted previously by the named authors. Only a few though show any adaptability to expendables. They are:

1. Concentric cylinders, one containing standard seawater and the other sample seawater.

Lawrence C. Murdock

Westinghouse Electric Corp.

2. Free falling probe containing a chamber with a small opening to admit seawater. Inner and outer electrodes are used to measure the conductivity.

Michael C. Gregg

S. Cox

United States of America as represented
by the Secretary of the Navy

3. Four electrode conductivity sensor for moored sensor chains.

Robert B. Sudar

Edward L. Lewis

Albert W. Koppel

Canadian Patents & Dev. Ltd.

4. Saline delay line.

Albert Benjaminson

Ocean Search, Inc.

5. Dual needle conductivity cell.

Arthur M. Pederson

Applied Physics Laboratory

The first three approaches named above are mechanically complex and would be expensive for an expendable. The saline delay line while appearing simple enough mechanically, does not lend itself to a simple self calibrated circuit. The thermistor, which must work with the conductivity cell is a resistive sensor. It is desirable then to have a conductivity cell which is also resistive. A resistance measurement is the easiest, and therefore, least expensive to implement. The dual needle approach by Pederson is a resistive sensor, but it is not a four electrode configuration. This sensor is designed for use in a stratified tank as a reference sensor. The stability of a two electrode cell is not at all good since polarization resistance and changes thereof cannot be calibrated out in an expendable in a practical manner. The cell must be stable and the sensitivities independent of polarization resistance. This is achieved only in a four electrode cell. The cell which Sippican has built and tested under the consultation of Neil Brown of Neil Brown Instruments, Inc., has to date demonstrated the capability of being constructed at a relatively low cost, shown repeatability in measurements, is resistive, and is expected to be stable since it uses four electrodes which are only immersed during calibration and deployment.

R-1259

Sippican Ocean Systems, Inc.

11.0 COST

A material breakdown of the XCTD components, manufacturing cost and calibration/test has yielded a sell price, based on 5,000 manufactured units/year, of \$180.00 each.

12.0 SCHEDULE

Attached is a schedule which shows past and future development and manufacturing milestones for both the XCTD and deckgear programs.

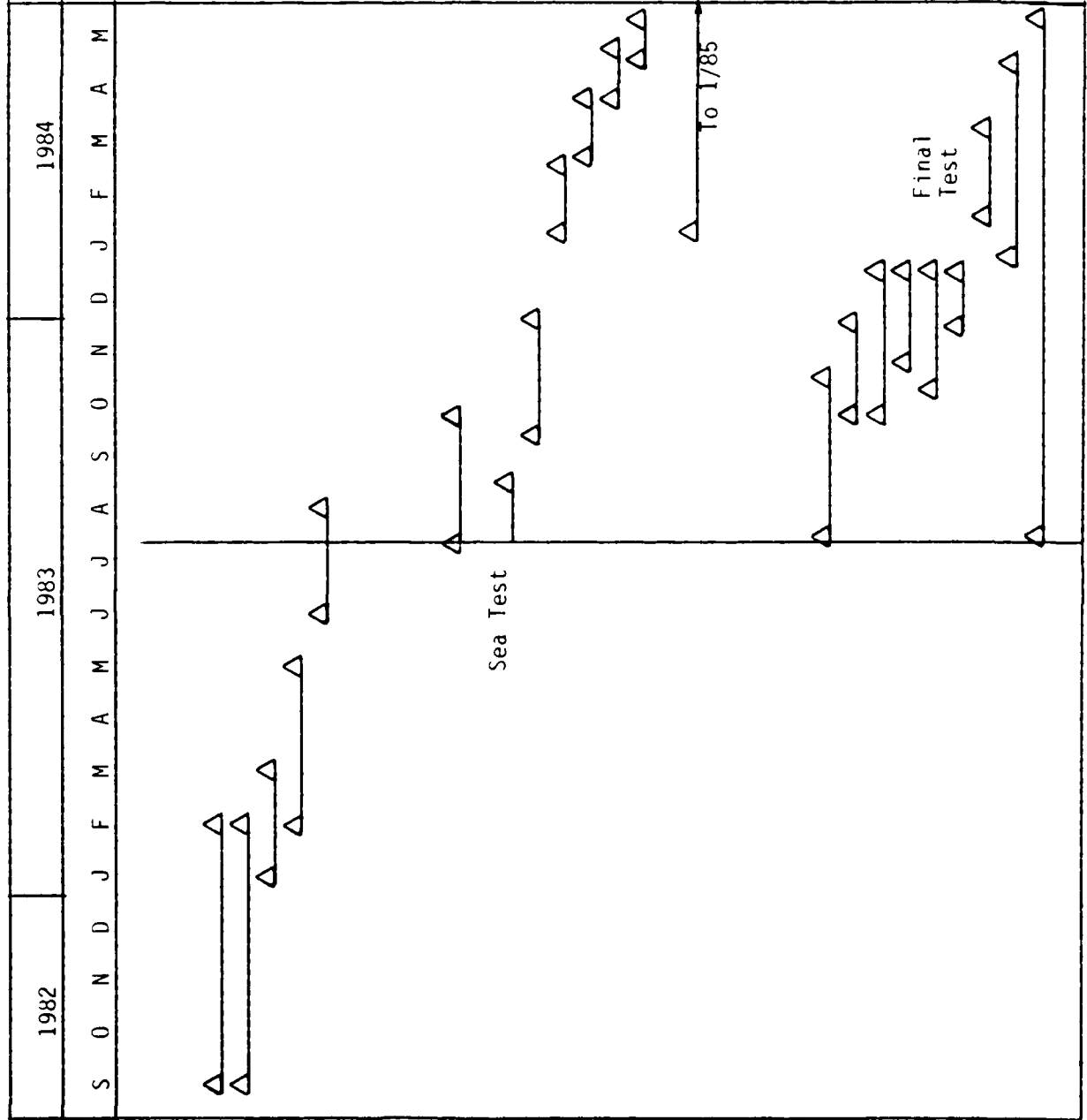

PROBE PHASE I

- 01 Conductivity
- 02 Temperature
- 03 Data Link
- 04 Test/Modify
- 05 Report

PROBE PHASE II

- 01 Packaging
- 02 Prototype Fab/Test
- 03 Tooling
- 04 Build 24
- 05 Test 24
- 06 Repeat 04,05
- 07 Final Report

Probe Custom IC
(Sippican Funded)

DECK GEAR (MK9)

- 01 Design Hardware
- 02 Build Prototypes
- 03 Design Software
- 04 Update Doc.
- 05 Prepare Drawings
- 06 System Integration
- 07 Testing, Lab & Sea
- 08 Production Support
- 09 Report, Proj. Eng.

D

C

B

1

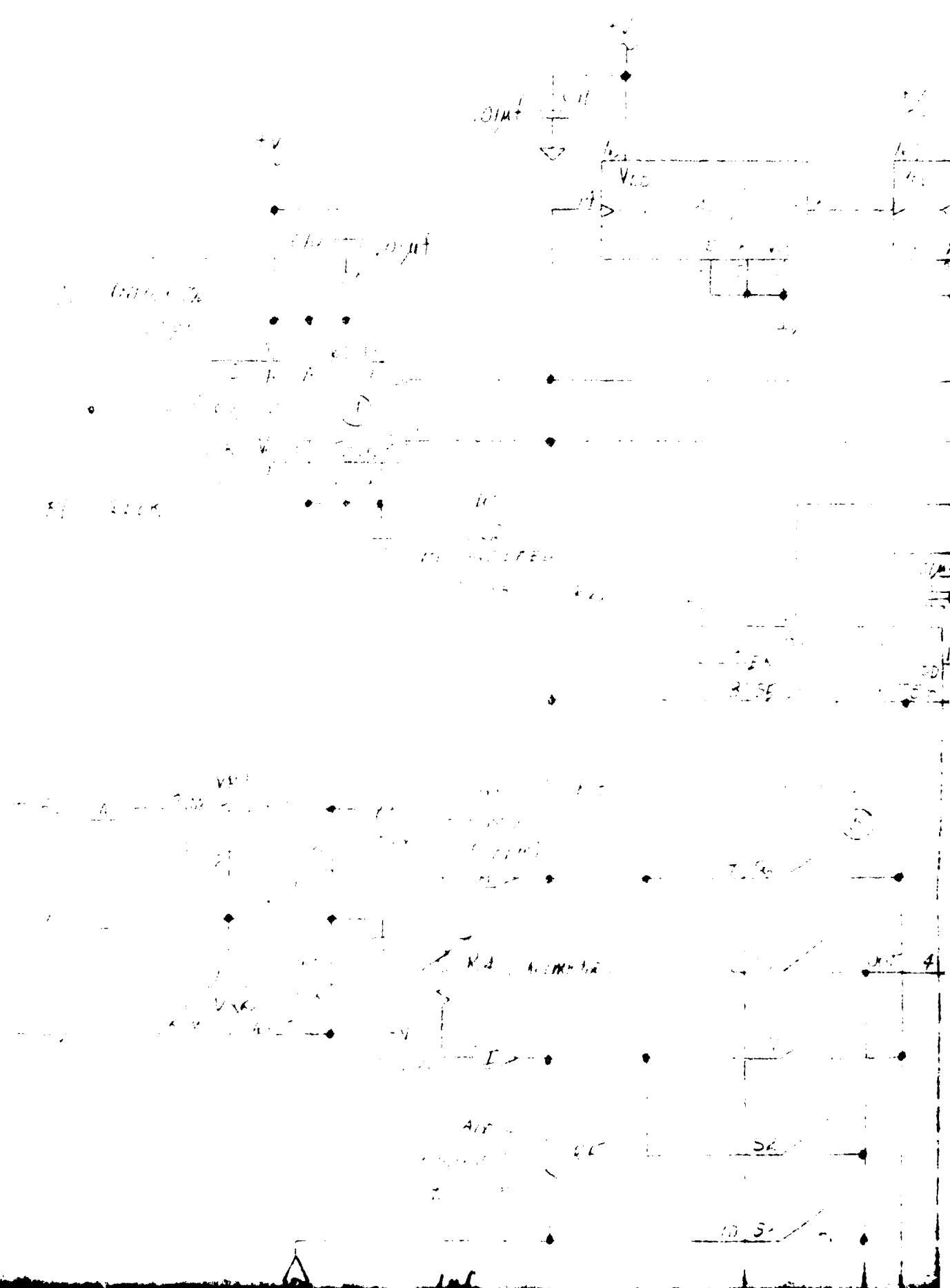

ZONE	REV

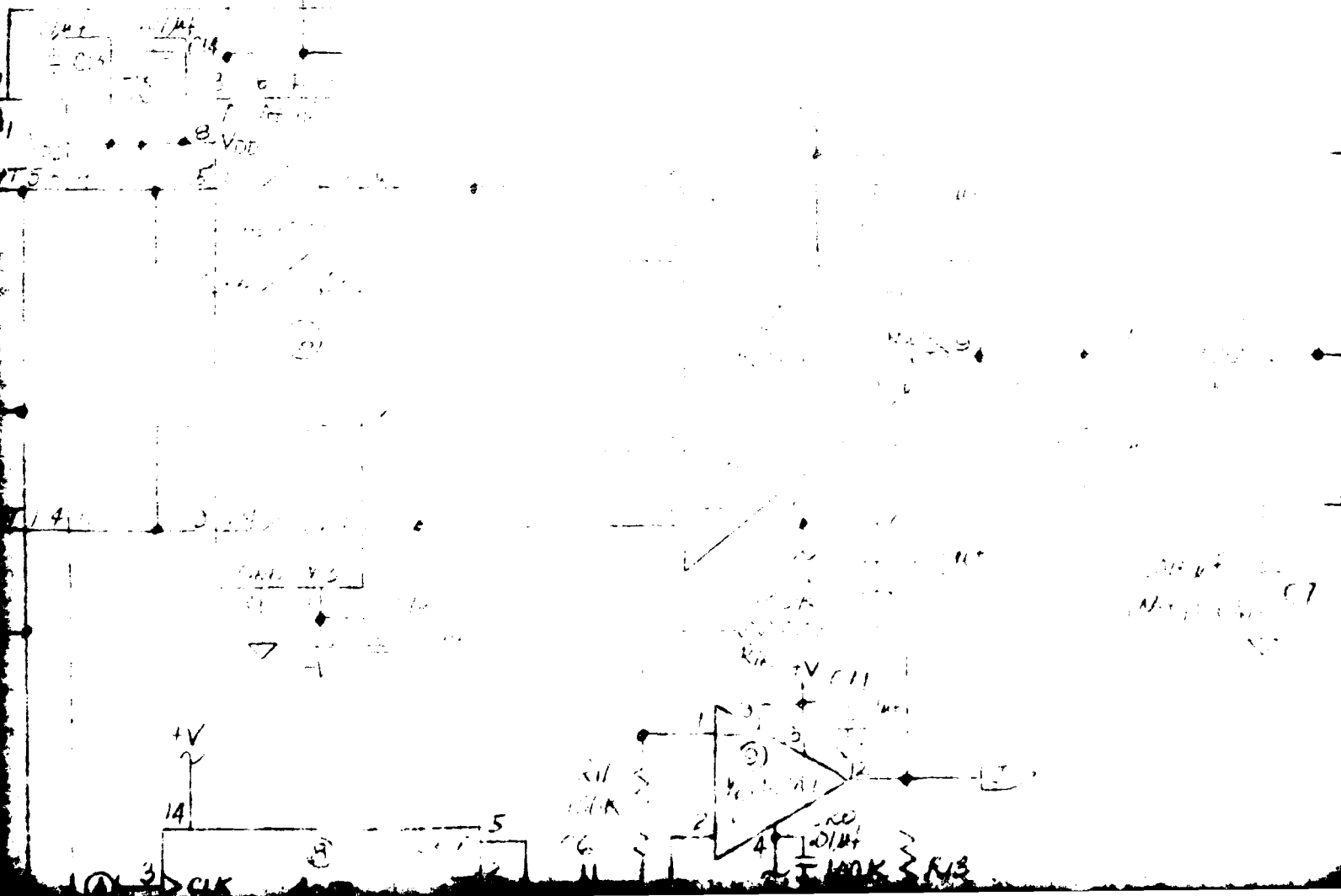

2

1

REVISIONS				
ZONE	REV	DESCRIPTION	DATE	APPROVED

D

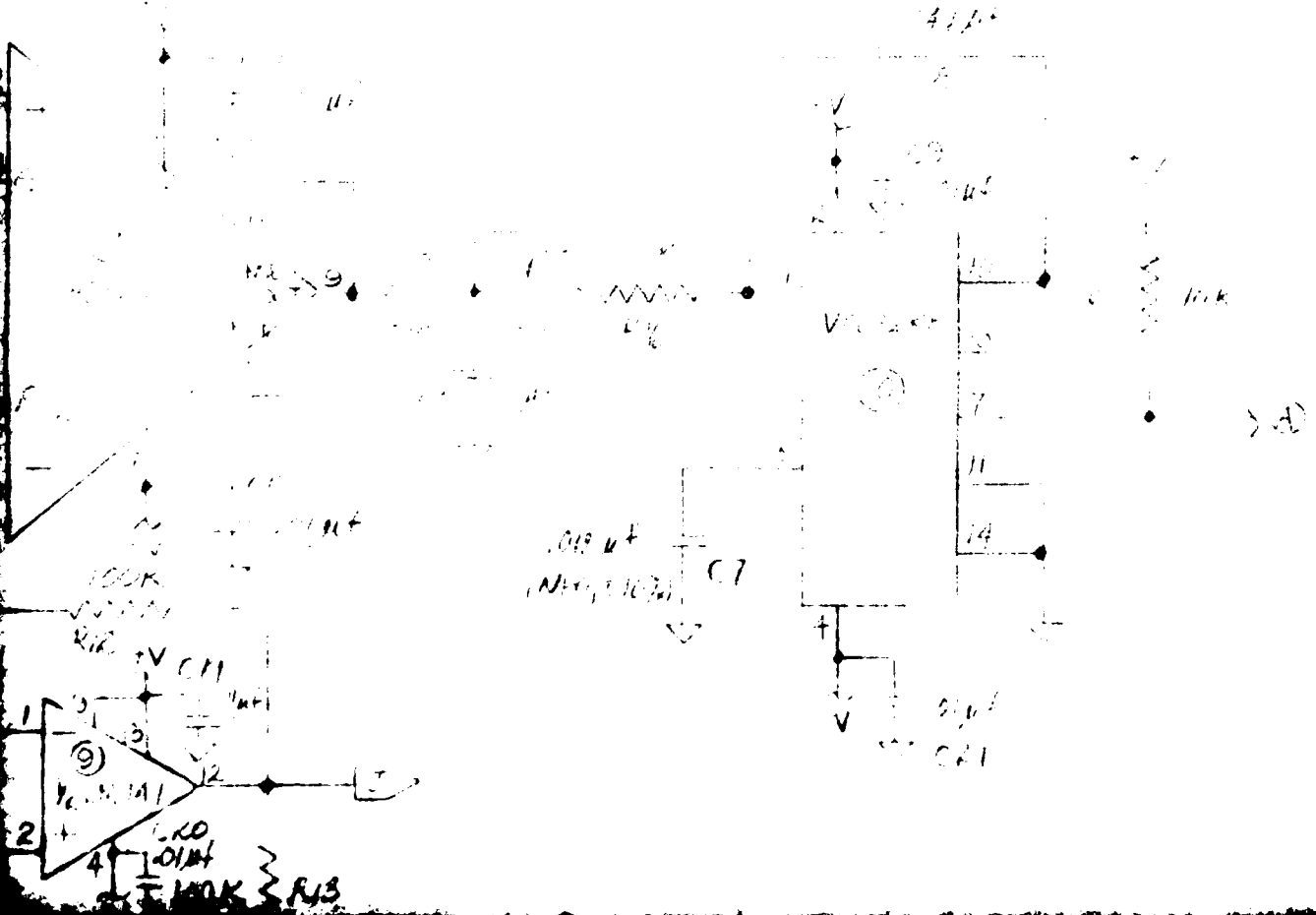
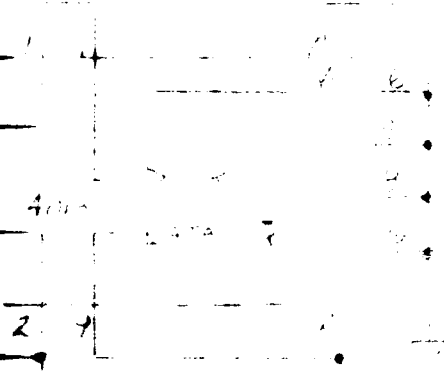

C

DWG NO.

C

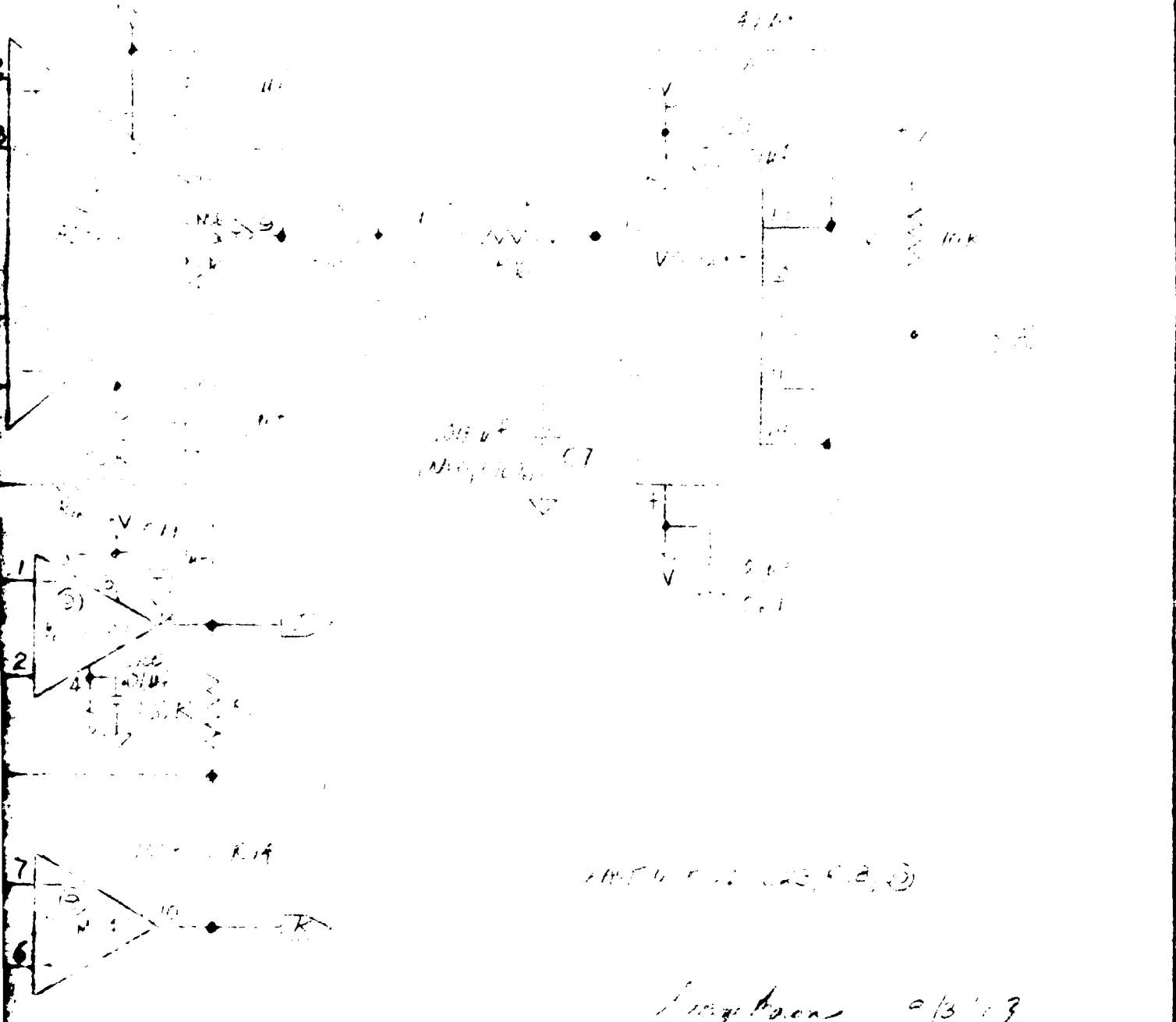

DWG NO

HS

100K 100K 100K 100K

5	4	3	2	FIRM OR VENDOR	PART NUMBER	DESCRIPTION	SPEC	REF DES OR ITEM NO
---	---	---	---	----------------	-------------	-------------	------	--------------------

PARTS LIST

DRAWN CHECKED PROJ ENG FNG PRJG QUA MFG DES ENG OTHER	UNLESS OTHERWISE SPECIFIED, TOLERANCES XXX = ± X = ± XX = ± ANGLES = ±	DO NOT SCALE DRAWING CONTRACT NO	Sippican Ocean Systems, Inc. MARION, MASSACHUSETTS	
	MATERIAL		TITLE XCTD PROBE SCHEMATIC (PRELIMINARY)	
		SIZE C	FSCM NO. 16848	DRAWING NO
		SCALE 		REV.
				SHEET OF

A

2

1

LMED
-8