

MICROCOPY RESOLUTION TEST CHART  
NATIONAL BUREAU OF STANDARDS-1963-A

AD A 131987

AFGL-TR-83-0062  
INSTRUMENTATION PAPERS, NO. 315

12



# A Balloon Design for 9000 Pounds at 90,000 Feet: Recommendations Based on Heavy-Load Balloon History

JAMES F. DWYER

9 March 1983

DTIC  
ELECTE  
AUG 31 1983  
S D  
B

Approved for public release; distribution unlimited.

AEROSPACE INSTRUMENTATION DIVISION      PROJECT 7659  
**AIR FORCE GEOPHYSICS LABORATORY**  
HANSCOM AFB, MASSACHUSETTS 01731

**AIR FORCE SYSTEMS COMMAND, USAF**



88 08 25 054

DTIC FILE COPY

This report has been reviewed by the ESD Public Affairs Office (PA)  
and is releasable to the National Technical Information Service (NTIS).

This technical report has been reviewed and  
is approved for publication.

  
DR. ALVA T. STAIR, Jr.  
Chief Scientist

Qualified requestors may obtain additional copies from the  
Defense Technical Information Center. All others should apply  
to the National Technical Information Service.

Unclassified

SECURITY CLASSIFICATION OF THIS PAGE (When Data Entered)

REPORT DOCUMENTATION PAGE		READ INSTRUCTIONS BEFORE COMPLETING FORM
1. REPORT NUMBER AFGL-TR-83-0062	2. GOVT ACCESSION NO. DD-AB1987	3. RECIPIENT'S CATALOG NUMBER
4. TITLE (and Subtitle) A BALLOON DESIGN FOR 9000 POUNDS AT 90,000 FEET; RECOMMENDATIONS BASED ON HEAVY-LOAD BALLOON HISTORY		5. TYPE OF REPORT & PERIOD COVERED Scientific, Final.
		6. PERFORMING ORG. REPORT NUMBER IP, No. 315
7. AUTHOR(s) James F. Dwver		8. CONTRACT OR GRANT NUMBER(s)
9. PERFORMING ORGANIZATION NAME AND ADDRESS Air Force Geophysics Laboratory (LCA) Hanscom AFB Massachusetts 01731		10. PROGRAM ELEMENT PROJECT, TASK AREA & WORK UNIT NUMBERS 62101F 76591115
11. CONTROLLING OFFICE NAME AND ADDRESS Air Force Geophysics Laboratory (LCA) Hanscom AFB Massachusetts 01731		12. REPORT DATE 9 March 1983
		13. NUMBER OF PAGES 40
14. MONITORING AGENCY NAME & ADDRESS (if different from Controlling Office)		15. SECURITY CLASS. of this report Unclassified
		15a. DECLASSIFICATION/DOWNGRADING SCHEDULE
16. DISTRIBUTION STATEMENT of this Report Approved for public release; distribution unlimited.		
17. DISTRIBUTION STATEMENT of the abstract entered in Block 20, (if different from Report)		
18. SUPPLEMENTARY NOTES		
19. KEY WORDS (Continue on reverse side if necessary and identify by block number) Free balloons                      Polyethylene balloons Tandem balloons                  Reinforced polyester balloons Single cell balloons              Heavy load balloons		
20. ABSTRACT (Continue on reverse side if necessary and identify by block number) The history of the development of free balloons to carry heavy payloads into the stratosphere is reviewed with the objective of developing a design based on existing technologies for a balloon to carry 9000 lb to 90,000 ft. Reinforced polyester balloons, in tandem balloon configurations, are discussed with respect to materials, design criteria, and performance. The problem of launch dynamics for single cell polyethylene balloons is also discussed and it is concluded that a capped single cell polyethylene balloon can be dynamically launched, successfully, with the 9000-lb payload. Further, it is concluded that		

DD FORM 1 JAN 73 1473 EDITION OF 1 NOV 65 IS OBSOLETE

Unclassified

SECURITY CLASSIFICATION OF THIS PAGE (When Data Entered)

Unclassified

SECURITY CLASSIFICATION OF THIS PAGE (When Data Entered)

20. (Contd)

the single cell polyethylene balloon is the best means to meet the objective. Specifications for such a balloon are provided.

Unclassified

SECURITY CLASSIFICATION OF THIS PAGE (When Data Entered)

## Preface

The modern plastic balloon continues to play a significant role in both scientific and military aerospace programs. Balloon grade films (down to 0.35 mils thickness) have been available for a little more than ten years to meet the needs of light payloads to very high altitudes—a few hundred pounds to 170,000 ft; on the other hand, the requirements for heavy payloads, on the order of four tons or more, continue to provide operational challenges. With the constructive criticisms of Mrs. Catherine Rice and Mr. Ralph J. Cowie, I have organized pertinent data to substantiate one proposed solution to this problem (specifically the design of a single cell, capped, polyethylene balloon to carry 9000 lb to 90,000 ft) and sufficient references to facilitate research by others interested in developing alternate solutions.

Accession		
Mo		
DTI		
Uncl		
Jun		
By		
Distribution		
Available to		
Available to		
Dist	Special	
<b>A</b>		

## Contents

1. OBJECTIVE	7
2. HISTORY OF THE HEAVY LOAD PROBLEM	7
3. THE APPROACH	11
4. A SOLUTION	14
5. CONCLUSIONS AND RECOMMENDATIONS	17
REFERENCES	19
APPENDIX A: A Review of Mylar-Dacron-Serim History	21
APPENDIX B: Weight Determination for Film Reinforced With Non-woven Serim	23
APPENDIX C: Tandem Balloon Systems	35

## Illustrations

1. Altitude Capability and Film Thickness Trends	8
2. Heavy-Load Platform Launcher	11
3. Heavy-Load Platform Launcher	12
4. Effect of the "Soft Collar" on the Dynamic Launch	14
5. Specifications for a Single Cell Capped Polyethylene Balloon to Carry a Payload of 9000 Pounds to 90,000 Feet	15

## Illustrations

6.	Dynamic Loading Index Statistics	16
7.	Specifications for a Single Cell Capped Polyethylene Balloon to Carry a Payload of 9,000 Pounds to 105,000 Feet	17
A1.	Load-strain Comparison of Reinforced Films in the Warp Direction at Room Temperature	23
A2.	Stress-strain Relationship for Reinforcing Fibers	24
A3.	S-10 Stress-strain Relationship	24
A4.	GT-10 Series Material Configuration	25
B1.	Schematic Representation of One-half of the Fill Thread Pattern for a Non-woven Scrim Reinforcement	30
B2.	Schematic Representation of the Flying Thread Loom (FTL) for Generating Non-woven Reinforcement Patterns for Mylar Film Laminates	30
B3.	FTL Non-woven Gore Reinforcement Patterns	33
C1.	Half View of Tandem Balloon Systems	36
C2.	Variation of the Shape of a Tandem-Balloon System as it Ascends to Altitude	37
C3.	Stratoscope II Launch Balloon Gas Transfer	38
C4.	Comparison of Theoretical and Experimental Relationship Between Non-dimensionalized Main Balloon Volume and Ratio of Net Upward Force $F$ on Main Balloon Apex and System Payload $P$	39

## Tables

1.	Results of Loading Analyses for the Launch Conditions	16
2.	Performance Table	16
3.	Results of Loading Analyses for the Launch Conditions	18
A1.	Some General Physical Properties of the Mylar Base Film Used in Balloons in the Early 1960s	22
A2.	Ultimate Tensile Strength (lb/in.) of S-10 at a Strain Rate of 40 percent per min	23
A3.	Some Properties of GT-11	26
A4.	Some Properties of Dacron Reinforced Mylar Film Laminates	27
C1.	Representative Heavy-Load Tandem Balloon Systems Made From Reinforced Mylar Film	40

## A Balloon Design for 9000 Pounds at 90,000 Feet: Recommendations Based on Heavy-Load Balloon History

### 1. OBJECTIVE

This report addresses the general problem of providing a heavy load, high altitude, free-balloon capability using available technologies. The specific objective is a set of specifications for a free balloon to carry a payload of 9,000 lb to 90,000 ft in the standard atmosphere - specifications that could be used immediately, if needed, as a basis for acquisition.

The general problem is *not new*; it is a recurring problem that must be addressed periodically as technologies and synthetic materials emerge, evolve, mature, and are replaced due to marketplace economics and in response to demands for increased capability and increased reliability. Finally the problem should be addressed when, as is now the case, we develop improved insights and understanding of the performance and failure mechanisms of balloon structural members.<sup>1</sup>

### 2. HISTORY OF THE HEAVY LOAD PROBLEM

The heavy load problem was addressed in the decade of the fifties by the development of double-die-extruded DFD 5500 polyethylene film, the development of natural

---

(Received for publication 7 March 1983)

1. Dwyer, J. F. (1982) Polyethylene Free Balloon Design From the Perspectives of User and Designer, AFGL-TR-82-0350, AD A127553.

shapes, the development of the moving band sealer, and finally by the development of heat-sealed load tapes.<sup>2</sup>

In the decade of the sixties, the capped polyethylene balloon was introduced by Winzen Research, Inc. (now Winzen International, Inc.) and both woven and non-woven dacron reinforcements were laminated to Mylar<sup>®</sup> film to provide a rip-stop feature that would enable the balloon manufacturers to make use of the Mylar's higher tensile strength (compared to polyethylene); this development of so called "scrim-balloon" films is discussed in Appendices A and B.<sup>4</sup>

Concurrent with the growth in payload weight requirements was the demand for higher altitude flight and thus lighter-weight (thinner) polyethylene films (Figure 1).

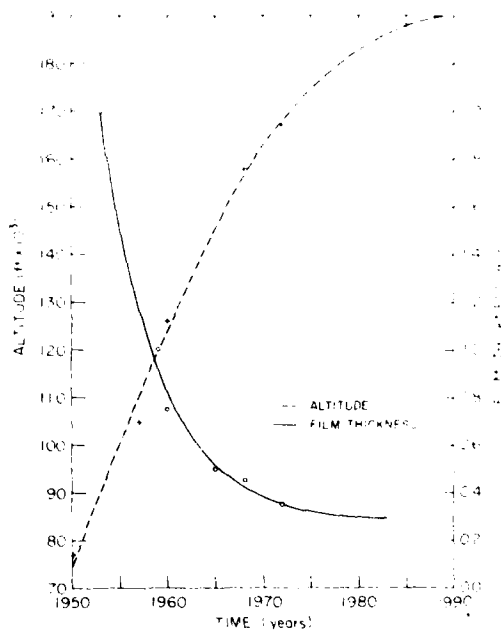

Figure 1. Altitude Capability and Film Thickness Trends

2. Dwver, J. F. (1978) Zero pressure balloon shapes, past, present, and future, Scientific Ballooning (COSPAR), W. Riedler, Editor, Pergammon Press, pp. 9, 19.

\* Appendices A, B, and C deal with reinforced polyester film development and tandem balloon systems which were developed to utilize these films. These appendices summarize the most significant history of the large tandem systems to provide the working knowledge needed to understand the conclusions and recommendations made herein. Sufficient information on the development of single cell polyethylene balloons exists in the literature and is included herein mostly by reference.

The effect of these requirements was an apparent change in the extruder die size to enable production of better balanced thinner films, but, inadvertently, poorly balanced thick films (2.0 mils) also resulted. These 2.0-mil films were involved in numerous balloon bursts which were subsequently found to correlate with differences in film behavior that were consistent with the suspected die change.

Because the rash of failures of heavy load polyethylene balloons was contemporary with the development of scrim balloons, immediate primary emphasis was shifted to reinforced films—with notable exceptions. Winzen Research, Inc. concentrated on the development of a superior polyethylene film which resulted in the qualification (for balloon use) of Stratofilm<sup>®</sup> in 1964. Raven Industries, Inc., in cooperation with the VisQueen Division of The Ethyl Corp., qualified a new film N-124 as a replacement for DFD 5500 film in 1967. In addition, the Air Force contracted with the Viron Division of the Geophysics Corporation of America to develop a balloon with a scrim-cap; this development was not successful. Raven Industries, Inc. pursued the development of various means to promote uniform deployment of the polyethylene balloon crown during the ascent phase from ground through the tropopause. Stratofilm alone remains in use today.

The scrim-balloon development at the G. T. Schjeldahl Company<sup>3</sup> in the early 1960's was accompanied by a systematic search for new balloon films under a contract with the Aerospace Engineering and Research departments of the Electronics Division of General Mills, Inc. During the early part of the contract, this group was purchased by Litton Industries and became the Applied Science Division of Litton Systems, Inc. Nothing comparable to Stratofilm resulted from this research. During the second half of the sixties, when scrim-balloons were being pushed to the limits of their capabilities, investigation of the polyethylene balloon ascent burst phenomenon was undertaken by Kerr and then Alexander; these studies produced significant findings.<sup>5, 6</sup>

In the early 1970's due to the higher cost of manufacturing scrim-balloons and due to flight failures of the scrim-balloons used on the CRISP<sup>3</sup> program, the less

3. Slater, R. J. (1961) Development of a Heavy-Load Carrying Balloon Using High-Strength and Tear-stopping Films, Progress Report on G. T. Schjeldahl Co. Contract NONR 2899(00).
4. Parsons, W. B. (1964) Survey of Currently Available Plastic Films, Scientific Report No. 1 on Contract AFI9(628)-2944.
5. Kerr, A. D., and Alexander, H. (1968) On a Cause of Failure of High Altitude Plastic Balloons, Scientific Report No. 5, Contract F19628-67-C-0241.
6. Alexander, H., and Weissmann, D. (1972) A Compendium of the Mechanical Properties of Polyethylene Balloon Films, Scientific Report No. 2, Contract F19628-69-C-0069, AFCRL-72-0068, AD 746678.

CRISP was a NASA cosmic ray experiment. The payload weight was about 14,000 lb—significantly greater than any that had been flown successfully.

expensive polyethylene balloons for moderately heavy payloads made a return; the improving quality of the already proven superior polyethylene, Stratofilm, most certainly played a significant role. Fading requirements for very heavy payloads de-emphasized scrim-balloons to the point where their production eventually became economically impractical.

To eliminate the effects of launch dynamics on the less "forgiving" Mylar film, the very heavy payload scrim balloons had been configured as tandem balloon systems rather than single cell balloons (see Appendix C). Primarily as a result of the successful introduction of Stratofilm, polyethylene balloons were quickly introduced, first as the main balloons of tandem systems and then as both launch balloon and main balloon thereby to constitute a total polyethylene tandem system. Polyethylene main balloons differed from the scrim main balloons in one significant way; the meridional reinforcements of the gores were along the gore seams rather than along the shorter gore centerlines. Consequently, the loading across the gores of the two types differed considerably, both at launch and during the subsequent ascent and float phases of flight, and thus the criteria for the design and structural analyses of these two types were not comparable.

As experience and confidence in the heavy load capabilities of Stratofilm increased, tandem polyethylene balloons were quickly and totally replaced by single cell polyethylene balloons and tandem balloon systems in general were relegated to history before they were fully understood, either structurally or from the point of performance potential. This return to single cell polyethylene balloons left unanswered the question: Does there exist a determinable configuration during ascent for which the loading at the apex of the main balloon of a tandem system is maximum—a critical loading condition? Such a condition is suggested by the facts. The main balloon gores, at the apex, are uniformly loaded only before the start of gas transfer and while the balloon is full (at or above the altitude at which the launch balloon has neutral buoyancy). The apex loading, when the main balloon is full, is about 30 percent higher than before the start of gas transfer, whereas during the transition all gores are not, in fact, loaded at all times; this non-uniform loading during the transition is evident in the ratios of deployed circumference to manufactured circumference (less than unity) and the differences between the gore lengths and the actual path lengths between the apex and base fittings of the main balloon. Appendix C provides additional background on this topic.

A tandem balloon system consisting of a scrim launch balloon and a polyethylene main balloon had, in 1971, carried an 6379-lb payload, and an all-polyethylene tandem system had carried, in 1972, a payload weighing 7424 lb. By comparison, the maximum payload, dynamically launched and flown successfully on a single cell polyethylene balloon, was 6300 lb on a 2421-lb balloon in 1974. The problem with

heavy payload single cell balloons continued to be the dynamics of the launch method, the standard heavy-load platform launchers (Figures 2 and 3) could not handle the high gross inflations, and, further, launch dynamics were thought to contribute to both launch and ascent balloon failures.

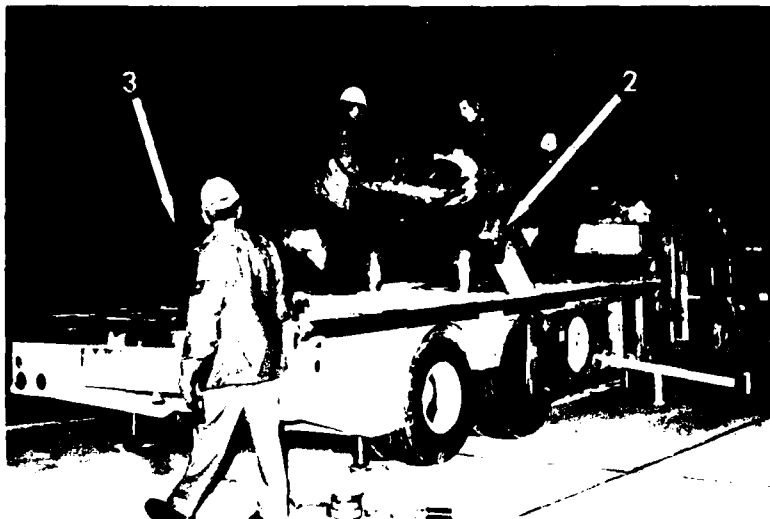

Figure 2. Heavy-Load Platform Launcher. The top of a single cell polyethylene balloon is shown being removed from its box (on a small trailer) and being laid out between the vertical guides on the stainless steel platform surface. The restraining roller is seen on the left in its full open position; once the balloon is in place, the roller will be swung shut and secured for inflation readiness. The weight of the platform is a factor governing the amount of lift that can be launched from it. Critical components include: (1) the net lift indicator, (2) the roller release mechanism, and (3) the restraining roller.

### 3. THE APPROACH

The design configuration of a balloon to carry a 9000-lb payload to 90,000 ft must be compatible with the launch method, be it static or dynamic, and with the balloon film, polyethylene, or polyester with either woven or non-woven dacron fibers.

Production facilities for large, reinforced polyester balloons do not exist today. Bi-axially balanced polyester film may or may not be readily or economically available.



Figure 3. Heavy-Load Platform Launcher. The view is toward the payload. The restraining roller arm is shown in the secured position. The net lift of the balloon acting on the roller will cause it to swing up and away from the balloon when released, thereby enabling the balloon to rise vertically to a point over the still restrained payload. The arrow indicates the pivot for the roller

Very heavy payloads have been carried on reinforced polyester films, most reliably when the reinforcement was an expensive leno weave scrim (GT-11 on Stratoscope II, and GT-12 on Project 770). Simulated use tests of the more economical non-woven dacron reinforcement laminated to polyester indicated stresses at failure one order of magnitude lower than expected.\* Further, non-woven reinforcements in simulated use tests tended to delaminate and cause failures much more so than did the leno weave reinforcement used in GT-11 and GT-12.<sup>7</sup> The third element in the laminate also presented problems: the adhesive had been found both to etch the film surface,<sup>8</sup> probably inducing crack propagation, and to become brittle at low

---

\*Alexander, H., Personal correspondence on the results of tests of CRISP balloon material.

7. Alexander, H., and Agrawal, P. (1972) An Evaluation of Fiber Reinforced Films Used in High Altitude Balloons, Scientific Report No. 3, Contract F19628-69-C-0069, AFCRL-72-0235, AD 749880.
8. Alexander, H. (1971) Quarterly Progress Report No. 9, Contract F19628-69-C-0069.

use temperatures sooner than either the polyester or the reinforcing varns.<sup>9</sup> These significant problems preclude timely use of reinforced polyester balloons—either single cell or tandem—to meet present objectives. For additional understanding of the problems associated with the use of reinforced polyester, I recommend the paper by Munson,<sup>10</sup> given at the Eighth AFCRL Scientific Balloon Symposium.

Polyethylene is the only other proven balloon film, and it has been used successfully in both single cell and tandem balloon systems. Single cell polyethylene balloons have been launched both dynamically and statically inflated while vertical above either the payload or a sheave which permitted the balloon, when fully inflated, to be winched to a point over the payload.

Designing a polyethylene tandem system in which one could have confidence would require extensive and time-consuming analysis of the redeployment process accompanying the transition of the main balloon from the in-line uninflated state to the fully deployed state at float altitude. It would further require detailed analyses of the few successful tandem polyethylene balloons flown to date, and development of a model to extrapolate this experience to the design of new tandem polyethylene systems to carry heavier payloads to higher altitudes.

Based on the foregoing facts and experiences, we are left with only one reasonable way to meet our requirement—that is to design a single cell polyethylene balloon to carry the 9000 pounds to 90,000 feet. The gross lift required for such a balloon exceeds both the capability of existing platform launchers and the realm of experience with static vertical inflations, but neither of these considerations should present an insurmountable obstacle or require the equivalent time and funds which would be needed to produce a reliable tandem system.

Based upon my recent polyethylene balloon design study<sup>1</sup> and successes by the National Scientific Balloon Facility (NSFB) using the "soft collar" to reduce or eliminate dynamic launch damage,\* it appears that the least complex system (though heaviest and therefore biggest) will result if a dynamic launch is specified; such a balloon design would require limited changes to make it suitable for a static launch (vertical inflation).

9. Niccum, R. J. (1972) Comparison of polyester film-varn composite balloon materials subjected to shear and biaxial loading, NASA Contract NAS1-10, 750, Report No. NASA CR-2047, p. 30.
10. Munson, J. B. (1974) Material selection for high-altitude, free flight balloons, Proceedings (Supplement), Eighth AFCRL Scientific Balloon Symposium 30 September to 3 October 1974, Andrew S. Carten, Jr., Editor, pp. 211, 240, AFCRL-TR-74-0393, AD A006200.

\*The "soft collar" is a choker to prevent transverse dynamic loading of the balloon gores and seams when the balloon "mushrooms" (is flattened by drag forces) as it rises from the launch platform to a vertical position above the payload (Figure 4).

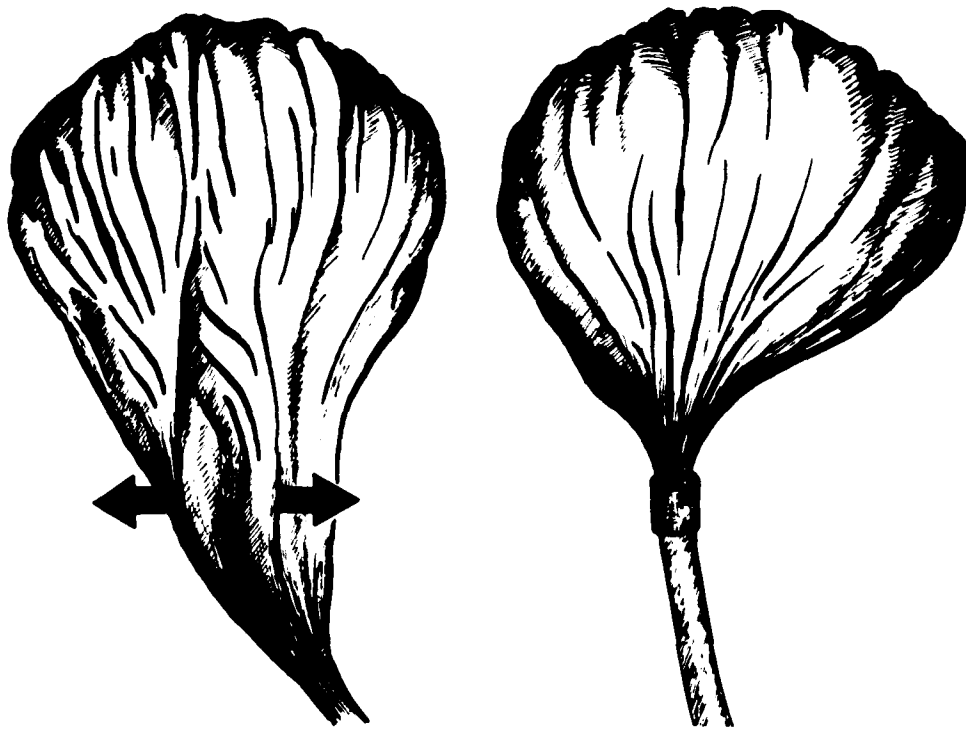

Figure 4. Effect of the "Soft Collar" on the Dynamic Launch. Transverse dynamic loading of the shell is greatly restricted

#### 4. ASOLUTION

Program "DESIGN-II(A)", documented in Reference 1, is an interactive computer program (basic language) which allows one to: (1) specify a balloon mission in terms of payload ranges, altitude, duration, ballast demands for vertical control, and safe terminal velocity for the payload recovery parachute, if desired, (2) adjust the polyethylene film thickness iteratively to define design features that will ensure design launch stresses and a dynamic launch loading within desired or statistically acceptable ranges.

Using program "DESIGN-II(A)" and specifying the requirement to fly a 9000-lb payload at 90,000 ft, and a useful operational payload range of 5000 to 10,000 lbs, we find one of a number of acceptable solutions (see Figure 5).

TARGET MIN. PAYLOAD	5000	
MAXIMUM PAYLOAD	10000	
DESIGN PAYLOAD	9000	
ALT. FOR DSGN. PAY.	90000	
SIGMA	0.16507	
SHELL THICKNESS	1.00	
CROWN THICKNESS	4.00	
DUCT AREA	130.00	
NUMBER OF DUCTS	2	
DUCT LOWER LIP	168	
VOLUME (MAX.)	8355966	
VOLUME (MIN.)	8119513	
BALLOON WEIGHT	3018	
SHELL WEIGHT		1012
CAP WEIGHT		1346
TAPE WEIGHT		489
SEAM WEIGHT		39
DUCT WEIGHT		75
MISCELLANEOUS WEIGHTS		57
GORE LENGTH	394.98	
GORE WIDTH	8.39	
MAX. DIA.	272.45	
SLEEVE LENGTH	214	
CAP LENGTH	176.40	
NUMBER OF GORES	102	
TAPE STRENGTH	950	

Figure 5. Specifications for a Single Cell Capped Polyethylene Balloon to Carry a Payload of 9000 Pounds to 90,000 Feet

Experience has shown that a 570 psi stress level at launch for such a balloon is quite satisfactory (see Reference 1). Table 1 shows the proposed solution to be satisfactory in this regard, and further, that the Dynamic Loading Index (see Figure 6) for a dynamic launch of this design,  $4.567 \text{ ft lb/in.}^2$ , would be less than one-half of the recommended maximum,  $10 \text{ ft lb/in.}^2$ . The development of this index of launch shock is also reported in Reference 1.

Finally, Table 2 presents the payload altitude capability of this design, over the recommended operational payload range.

Table 1. Results of Loading Analyses for the Launch Conditions (Reference Figure 5)

	Merid.	Circ.
Strain (dim)	0.00994	0.01319
Sec. Mod. (psi)	16216	15511
Radius (ft)	62.64	8.06
Stress (psi)	569	574
% Safe Stress	56.63	57.16
Shock Index (ft lb/in. <sup>2</sup> ) 4.567		
Tape Load (lb) 93		
% Max Tape Load 9.74		

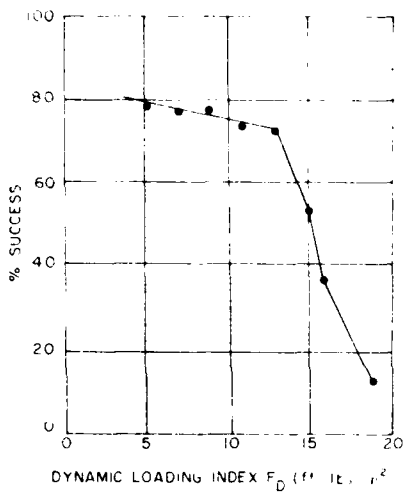

Figure 6. Dynamic Loading Index Statistics. The dynamic loading index or shock index is defined by the function  $F_D = (A-B)S/T^2$ ; where A is the gross lift of the system, B is the weight of the balloon, S is the length of the uninflated balloon and T is the balloon shell thickness. Forces are in pounds, the length in feet and the shell thickness in inches.

Table 2. Performance Table

Payload (lb)	Altitude (ft)	Payload (lb)	Altitude (ft)	Payload (lb)	Altitude (ft)	Payload (lb)	Altitude (ft)
5013	99060	6300	95680	7600	92740	8900	90180
5100	98820	6400	95440	7700	92540	9000	89990
5200	98540	6500	95200	7800	92320	9100	89800
5300	98260	6600	94960	7900	92120	9200	89620
5400	97980	6700	94720	8000	91920	9300	89440
5500	97720	6800	94500	8100	91720	9400	89260
5600	97460	6900	94280	8200	91520	9500	89090
5700	97200	7000	94040	8300	91320	9600	88920
5800	96920	7100	93820	8400	91120	9700	88740
5900	96680	7200	93600	8500	90930	9800	88560
6000	96420	7300	93380	8600	90740	9900	88400
6100	96160	7400	93160	8700	90540	10000	88220
6200	95920	7500	92960	8800	90360		

## 5. CONCLUSIONS AND RECOMMENDATIONS

The foregoing solution to the objective-problem has additional implications, particularly with respect to the possible requirement for a higher flight altitude with the same payload range. Figure 7 shows the specifications for such a requirement, a balloon to carry 9000 lb to 105,000 ft. The volume of this balloon is about 2.23 times as large as that required for the 9000 lb at 90,000 ft, while the balloon weight is about 39 percent larger. This greater performance is possible with the same shell and crown thicknesses and same total tape strength (within 2 percent). The static launch stresses (Table 3) for the higher altitude system are even slightly less, but the dynamic launch shock index, although acceptable, is about 31 percent higher—not an unexpected result in view of the greater gross weight of the system and the longer balloon gorelength. The smaller static launch stresses for the larger gross lift at launch are due to the narrower gore width at the gore position for which static launch stresses are computed. The narrower gore width results from the increased number of gores, 134 as opposed to 102.

TARGET MIN. PAYLOAD	5000	
MAXIMUM PAYLOAD	10000	
DESIGN PAYLOAD	9000	
ALT. FOR DSGN. PAY.	105000	
SIGMA	0.20933	
SHELL THICKNESS	1.00	
CROWN THICKNESS	4.00	
DUCT AREA	120.00	
NUMBER OF DUCTS	3	
DUCT LOWER LIP	218	
VOLUME (MAX.)	18602664	
VOLUME (MIN.)	18008760	
BALLOON WEIGHT	4209	
SHELL WEIGHT		1726
CAP WEIGHT		1500
TAPE WEIGHT		716
SEAM WEIGHT		59
DUCT WEIGHT		140
MISCELLANEOUS WEIGHTS		67
GORE LENGTH	512.94	
GORE WIDTH	8.40	
MAX. DIA.	358.08	
SLEEVE LENGTH	327	
CAP LENGTH	181.92	
NUMBER OF GORES	134	
TAPE STRENGTH	775	

Figure 7. Specifications for a Single Cell Capped Polyethylene Balloon to Carry a Payload of 9000 Pounds to 105,000 Feet

Table 3. Results of Loading Analyses for the Launch Conditions (Reference Figure 7)

	Merid.	Circ.
Strain (Dim)	0, 00985	0, 01263
Sec. Mod. (psi)	16239	15618
Radius (ft)	71, 72	7, 46
Stress (psi)	555	560
% Safe Stress	55, 30	55, 77
<hr/>		
Shock Index (ft lb in. <sup>2</sup> )	6, 004	
Tape Load (lb)	75	
% Max Tape Load	9, 65	

Finally, Munson's findings<sup>10</sup> suggest a logical next step in the development of heavy load, high altitude, single cell, free balloons—investigation of serim-reinforced polyethylene balloons or possibly more simply, the use of serim-reinforced caps for standard single cell polyethylene balloons. The experience gained during the unsuccessful polyethylene-serim development program at the Vicon Division of the Geophysics Corporation of America should provide a starting point for such a new technology.

## References

1. Dwyer, J. F. (1982) Polyethylene Free Balloon Design From the Perspectives of User and Designer, AIGI-TR-82-0350, AD A127553.
2. Dwyer, J. F. (1978) Zero pressure balloon shapes, past, present, and future, Scientific Ballooning (COSPAR), W. Riedler, Editor, Pergamon Press, pp. 9, 16.
3. Slater, R. J. (1961) Development of a Heavy-Load Carrying Balloon Using High-Strength and Tear-Stopping Films, Progress Report on G. T. Schjeldahl Co. Contract NONR 2079700.
4. Parsons, W. B. (1964) Survey of Currently Available Plastic Films, Scientific Report No. 1 on Contract F19628-67-C-0241.
5. Kern, A. D., and Alexander, H. (1968) On a Cause of Failure of High-Altitude Plastic Balloons, Scientific Report No. 5, Contract F19628-67-C-0241, AF-CRL-68-0456, AD 692173.
6. Alexander, H., and Weissmann, D. (1972) A Comparison of the Mechanical Properties of Polyethylene Balloon Films, Scientific Report No. 2, Contract F19628-67-C-0069, AF-CRL-72-0068, AD 746678.
7. Alexander, H., and Agrawal, P. (1972) An Evaluation of Fiber Reinforced Films Use in High-Altitude Balloons, Scientific Report No. 3, Contract F19628-69-C-0069, AF-CRL-72-0235, AD 749880.
8. Alexander, H. (1971) Quarterly Progress Report No. 9, Contract F19628-69-C-0069.
9. Niccum, R. J. (1972) Comparison of polyester film-yarn composite balloon materials subjected to shear and biaxial loading, NASA Contract NAS1-10,750, Report No. NASA CR-2047, p. 30.
10. Munson, J. B. (1974) Material selection for high-altitude, free flight balloons, Proceedings (Supplement), Eighth AF-CRL Scientific Balloon Symposium 30 September to 3 October 1974, Andrew S. Caeten, Jr., Editor, pp. 211, 240, AF-CRL-TR-74-0393, AD A006200.

## Appendix A

### A Review of Mylar-Dacron-Scrim History

A 1961 Schjeldahl report<sup>A1</sup> describes the development of the original family of dacron-reinforced Mylar films. \* Schjeldahl defined the development objectives as:

1. Tensile strength; 25 lb/in. (minimum)
2. Weight; 0.01224 lb/ft<sup>2</sup> (maximum)
3. Temperature Range; -90° F to +200° F
4. Tear propagation; none
5. Delamination; none (over indicated temperature range and under pressure and radiation conditions of flight)
6. Helium gas permeability; equal to or less than polyethylene

The primary laminate resulting from this development was a laminate of 0.25 mil Mylar and a 6 x 4 dacron leno scrim, 54 in. wide. The adhesive was a polyester resin adhesive (GT-100) made by the G.T. Schjeldahl Company. The dacron scrim weighed 0.004409 lb/ft<sup>2</sup>. The test results on 31 rolls of laminate showed:

---

A1. Slater, R.J. (1961) Development of a Heavy-Load Carrying Balloons Using High Strength and Tear Stopping Films, G.T. Schjeldahl Co., Contract NONR 2899(00).

See Table A1 for general physical properties of the Mylar base film.

	<u>Mean</u>	<u>Std Dev</u>	<u>Dimensions</u>	<u>99% Confidence Level</u>
Weight	0.0083	0.00046	lb/ft <sup>2</sup>	0.00968
Tensile Strength <sup>†</sup>	40.4	1.91	lb/in.	34.7
Tear Resistance <sup>†</sup>	32.8	2.29	lb	

<sup>†</sup> Direction and temperature unspecified.

Table A1. Some General Physical Properties of the Mylar Base Film Used in Balloons in the Early 1960's. Values are averages

Property	Value	Unit of Measure	Test Method
Melting Point	250-255	°C	-
Density	1.39	gm/cc	Density Gradient Tube
Refractive Index	1.655	n <sub>D</sub> 25	Abbe' Refractometer
Area Factor	20,000	in. <sup>2</sup> /lb/mil	-
Tensile Strength	17,000-25,000	psi	Instron Tensile Tester
Tensile Modulus	450,000-600,000	psi	Instron Tensile Tester
Impact Strength	60 (1 mil)	kg cm	Falling Ball
Break Elongation	70-130 (1 mil)	%	Instron Tensile Tester
Tear Strength	15 (1 mil)	g	Cellophane Tear Tester
Flex Life, 0° F	20,000 (1 mil)	cycles	DuPont Yerkes Flex Tester
Bursting Strength	45 (1 mil)	lb/in. <sup>2</sup>	Mullen
Bending Recovery (immediate)	43 (1 mil)	%	Recovery from 180° Bend
Bending Recovery (60 sec)	51 (1 mil)	%	Recovery from 180° Bend
Thermal Coefficient of Linear Expansion	15 × 10 <sup>-6</sup>	in./in./°F	70-120° F
Humidity Coefficient of Linear Expansion	11 × 10 <sup>-6</sup>	in./in./% R.H.	20-92% R. H.
Coefficient of Thermal Conductivity	3.63 × 10 <sup>-4</sup>	cal/cm/sec/°C	Cenco-Fitch Method
Oxygen Permeability	0.90 (1 mil)	g/100 m <sup>2</sup> /hr	Modified General Foods Tester
Water-vapor Permeability, 39.5° C 53 mm Hg Vapor Pressure Difference	110 (1 mil)	g/100 m <sup>2</sup> /hr	DuPont Film Moisture Vapor Permeability Test
Moisture Absorption	Less than 0.5	%	Water Immersion

Table A1. Some General Physical Properties of the Mylar Base Film Used in Balloons in the Early 1960's. Values are averages (Contd)

Property	Value	Unit of Measure	Test Method
Shrinkage (150°C)	1.5-2	%	30-min Exposure
Fungus Resistance	Excellent	-	12 Months Soil Burial
Corrosive Effective on Copper	Negligible	-	-

Strip tensile tests of the laminate yielded the results in Table A2 and it was noted that film and fibers failed simultaneously. It is interesting to note that failure of the S-10 dacron-Mylar laminate as shown in Figure A1 is consistent with a fiber tenacity of about 6.1 g/denier at failure, a figure that agrees closely with the dacron fiber load-strain response shown in Figure A2.

Table A2. Ultimate Tensile Strength (lb/in.) of S-10 at a Strain Rate of 40 Percent per min. Average is based on five tests

Temperature °F	Warp			Fill			Seam		
	Min	Avg	Max	Min	Avg	Max	Min	Avg	Max
70	37	39.6	41	31	31.2	32	27	28.6	31
-70	31	40.4	47	25	27.0	28	23	24.4	26

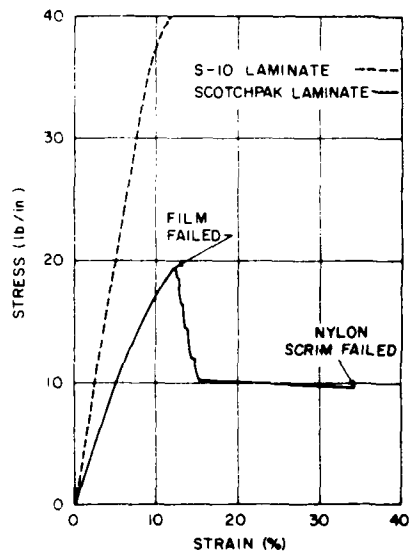

Figure A1. Load-strain Comparison of Reinforced Films in the Warp Direction at Room Temperature

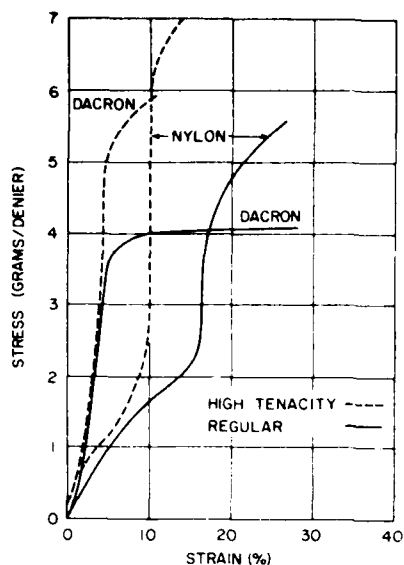

Figure A2. Stress-strain Relationship for Reinforcing Fibers

The machine and traverse direction strengths at both room temperature and  $-70^{\circ}\text{F}$  are shown in Figure A3: the machine direction properties being 40 lb/in. tensile strength and 13 percent elongation at room temperature and 35 lb/in. tensile strength and 3.5 percent elongation at  $-70^{\circ}\text{F}$ .

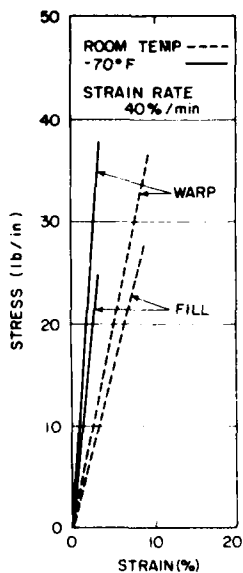

Figure A3. S-10 Stress-strain Relationship

Cylinder tests of the S-10 material at  $-70^{\circ}$  F indicated a transverse strength of 25 to 26 lb/in. and no propagation of the failure.

An analysis of laminate weight by components shows that the adhesive weight was, on the average,  $0.002179 \text{ lb/ft}^2$ . With the scrim used this amounts to nearly 0.494 lb of adhesive per pound of scrim (see also Appendix B).

The resultant weights for laminates using 0.35 and 0.50 mil Mylar were 0.0088 and  $0.0103 \text{ lb/ft}^2$  respectively.\*

Information on scrims in the years 1962 and 1963 is sparse. However, Slater<sup>A2</sup> reported that the adhesive system used in the GT-10, GT-11, and GT-12 laminates was the GT-301 adhesive system (Figure A4). Table A3 extracted in part from a paper by Kelly<sup>A3</sup> indicates testing at  $-80^{\circ}$  F, but the ultimate elongation appears significantly different from those in Figure A3; 13 percent to 16 percent as opposed to 3.5 percent. Also, the tensile strengths given by Kelly are, in some cases, in excess of those shown in Figure A3.

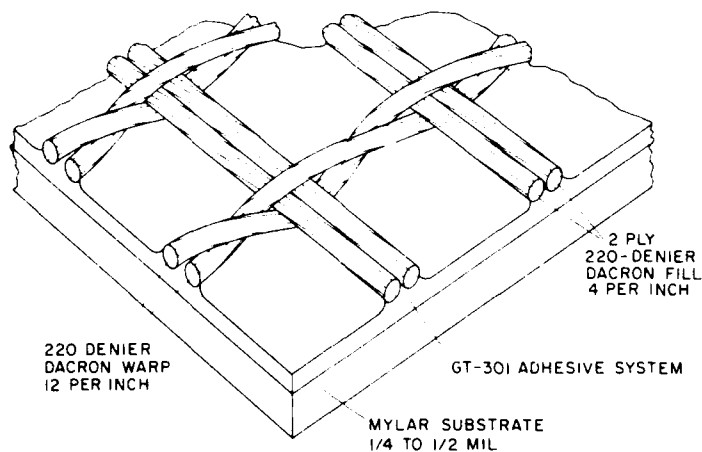

Figure A4. GT-10 Series Material Configuration

\*This concludes information up to February 1961.

A2. Slater, R.J. (1963) Expanded use of inflatables through new materials, Proceedings of the AFCRL Scientific Balloon Symposium, pp. 41, 65, AFCRL-63-919, AD 614065.

A3. Kelly, T.W. et al (1965) Quality engineering of scrim reinforced balloons, Proceedings, 1964 AFCRL Scientific Balloon Symposium, A.O. Korn, Jr., Editor, pp. 317, 330, AFCRL-65-486, AD 619695.

Table A3. Some Properties of GT-11

Property	Value
Weight ( $g/vd^2$ )	36.2
Warp tensile strength (lb/in.) at R. T.	38.8
% elongation at room temperature	12
Warp tensile strength (lb/in.) at $-80^\circ F$	51.4
% elongation at $-80^\circ F$	13
Fill tensile strength (lb/in.) at $-80^\circ F$	42.5
% elongation at $-80^\circ F$	16
Ply adhesion (ppi) at $-80^\circ F$	1.3
Seal tensile strength (lb/in.) at $-80^\circ F$	43.6
Flex test (pass/fail)	Pass

Table A4 published by the G. T. Schjeldahl Co. does not reflect any low temperature properties but does show a change from a hook tear strength of 32.8 lb to 60 lb and an upper service temperature of  $110^\circ F$ . However, it is not clear whether any tensile testing was ever conducted at the  $110^\circ F$  temperature. It is quite possible that film loads at such relatively warm launch temperatures may effect changes in the subsequent mechanical responses at the lower atmospheric temperatures; our research has shown this to be true for polyethylene films. It should also be noted that ply adhesion values published in Table A4 do not appear in the earlier references.

As far as the adhesives used in the laminates, four are mentioned, GT-100, GT-201, GT-300, and GT-301. Both GT-300 and GT-301 are coated Mylar substrates implying that the films are adhesive coated prior to lamination with the dacron fibers. The reference to the use of GT-100 was in the report of the original development of S-10. It is understood that the S-10 material had a blocking problem associated with the use of GT-100. Slater, at the 1963 AFCRL Symposium, gave GT-301 as the adhesive system used in the GT-10, GT-11, and GT-12 laminates. The value engineering study<sup>A4</sup> performed under AFCRL Contract AF 19(628)-2929 refers to GT-300 and GT-201. Apparently, GT-300 was used to prepare preproduction test laminates and the GT-11 production lamination process had changed over to use of a thermosetting liquid adhesive, thereby eliminating the need to precoat the film with adhesive.

A4. Curtis, L. W. (1965) Reduction of Scrim Reinforced Balloon Cost, G. T. Schjeldahl Co., Final Report Contract AF 19(628)-2929.

Table A4. Some Properties of Dacron Reinforced Mylar Film Laminates

Property	GT-10	GT-11	GT-12	GT-50	GT-66	GT-67
Film thickness (mils)	0.25	0.35	0.50	0.50	0.25	0.50
Weight (lb. 1000 ft <sup>2</sup> )	9.309	10.044	11.024	10.289	2.694	12.248
Warp Tensile Strength (lb./in.)	40	40	40	20	5 <sup>†</sup>	40
Fill Tensile Strength (lb./in.)	20	20	20	12 <sup>†</sup>	5 <sup>††</sup>	40
Available Width (in.)	58	58	58	52	52	58
Break Elongation (%)	20	20	20	15	15	20
Hook Tear (lb.)	60	60	60	20	5	60
Ply Adhesion (lb./in.)	1.5	1.5	1.5	1.6	0.5	1.5
Permeability (liters in <sup>2</sup> /100)	1.75	1.75	1.75	1.75	4.0	1.75
Min Service Temp. (°C)	-80	-80	-80	-80	-80	-80
Max Service Temp. (°C)	+110	+110	+110	+110	+110	+110

<sup>†</sup>in center 10 in.

<sup>††</sup>Diagonal direction

In the low temperature (-70° F) test of Cylinder Test Balloon No. 1, Curtis<sup>A4</sup> noted that the failure stress (FD) was almost equal to the diagonal strength, but in his enthusiasm he failed to take note that the Mylar failed leaving the scrim intact; a strict violation of contract objective Number 2, namely that the "scrim must fail before plastic film". This objective, however, contradicts use of fibers as a rip stop agent.

This covers the time span from the development of S-10 through the development of laminates of Mylar and non-woven dacron scrim. It should be noted that, in this five-year period, there was no comparative study of the Mylar film properties, as opposed to the laminates' mechanical properties.

The properties of the base Mylar, the adhesive and the dacron fibers most certainly influence the laminate properties. However, the properties are not necessarily additive; that is, if a 1-in. wide Mylar strap elongated 10 percent exerts a restoring force of 5 lb and a particular parallel array of Dacron fibers elongated 10 percent exerts a restoring force of 5 lb, a laminate of these two constituents would not necessarily, when elongated 10 percent, exert a restoring force of 10 or even 9 lb. It would greatly simplify the engineering problems if the strength properties of a laminate always equalled (or exceeded in a predictable way) the sum of the corresponding properties of the constituents, but this is not generally the case. For one thing Mylar is not an isotropic material. Its properties vary both directionally and with respect to sample location along and across any given roll. Also

in the lamination process, the Mylar (and presumably the Dacron fibers) shrinks in the transverse direction and elongates in the meridional direction.

A critical factor in fixing the laminate properties is the adhesive used to bond the fibers to the film. There are both quantitative and qualitative property variations due to the relative imprecision of the lamination process controls and due to normal fluctuations in the lamination environment. The influence of adhesive is additionally complicated because laminates have been made variously with adhesive coated film, adhesive pre-coated thread and in process application of adhesive to the threads.

Finally, the behavior of a laminate is strongly dependent upon the pattern of the reinforcing fibers. Thus we have a laminate whose properties vary with:

- (1) Initial properties of constituents and their individual variability,
- (2) Proportions and geometry of constituents,
- (3) Changes (and degree of variability of changes) of constituent properties as a result of the lamination process.

The foregoing would be complicated enough if the Mylar, adhesive and Dacron fibers were the same for each laminate with which we have had experience. This, however, has not been the case. There have been two types of Mylar (not always specified), a variety of "types" and "merges" of Dacron fibers and a spectrum of adhesives (presumably of the same family).

There was no reported in-depth study of "actual" versus "predicted" properties of the laminates (modulus, strength, ultimate elongation, weight, rip stop, random cold temperature flexure, and so on). Any future materials research on similar laminates should take the foregoing into consideration.

## Appendix B

### Weight Determination for Film Reinforced With Non-Woven Scrim

The weight per unit area of a laminate of film and a non-woven scrim is a function of the weight per unit area of the film,  $W_f$ , the total length and weight per unit length for each type of reinforcing thread and the weight of the adhesive used to bond the threads and film.

Figure B1 shows one half of the fill thread configuration generated by the AFCRI Flying Thread Loom (Figure B2). If  $L_x$  is the total length (in feet) of the fill threads in an area  $\underline{Y}$  feet wide and  $\underline{Z}$  feet long, we can compute the length,  $L_x$ , from the following equation:

$$L_x = 2 \left[ N_1 + 2(N_2 + N_3 + \dots + N_{m-1} + N_m) \right]$$

where  $N_i$  is the length of the  $i^{\text{th}}$  fill thread.

If we now define  $N_x$  as one half of the number of fill threads per foot of warp direction length and  $m$  as one half of the number of fill threads per length  $Z$  (measured in feet) in the warp direction, then the length in feet of the  $i^{\text{th}}$  fill thread can be shown to be:

$$N_i = (m - i + 1) / (N_x \cos \theta),$$

where  $\theta$  is the acute angle between the warp and fill directions.

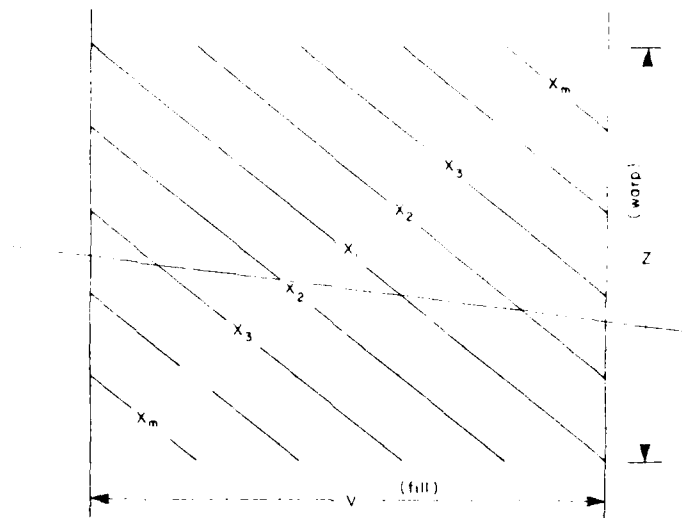

Figure B1. Schematic Representation of One Half of the Fill Thread Pattern for a Non-woven Scrim Reinforcement

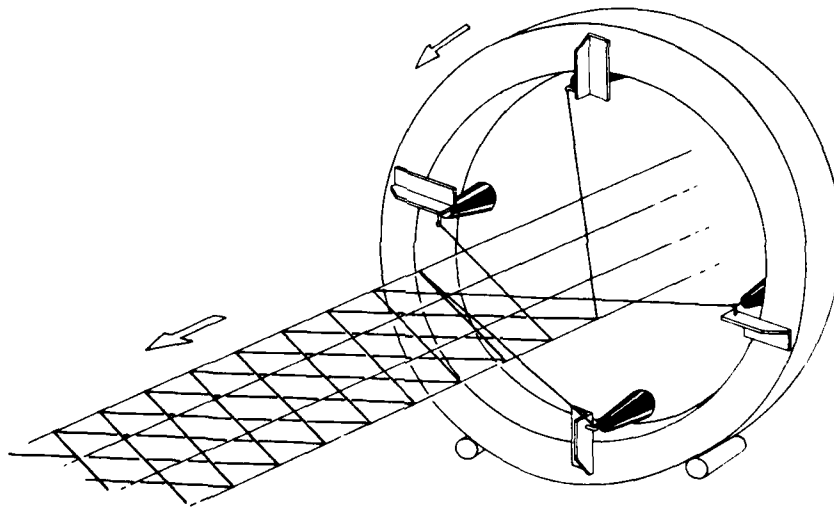

Figure B2. Schematic Representation of the Flying Thread Loom (FTL) for Generating Non-woven Reinforcement Patterns for Mylar Film Laminates. The dacron thread grid is fed directly into the laminator to produce reinforced Mylar gores for the balloons

The value of  $L_x$  can thus be shown to be:

$$L_x = 2 \left[ \frac{m}{N_x \cos \theta} + 2 \sum_{i=2}^m X_i \right] = 2 m^2 / (N_x \cos \theta) .$$

If we define  $\omega_x$  as the unit fill thread weight (pounds per foot of length per denier),  $d_x$  as the fill thread denier and  $W_x$  as the fill thread weight per unit area (pounds per square foot), then we can write:

$$W_x = \omega_x d_x L_x / V / Z = 2 \omega_x d_x N_x / \sin \theta .$$

Similarly if we define  $N_v$  as the number of warp direction threads per foot of fill width,  $\omega_v$  as the unit warp thread weight (pounds per foot of length per denier),  $d_v$  as the warp thread denier and  $W_v$  as the warp thread weight per unit area (pounds per square foot), we can write:

$$W_v = \omega_v d_v N_v .$$

Now the "Ideal Laminate" weight,  $W^*$ , where  $W_f$  is the base film weight (lb/ft<sup>2</sup>) and where it is exclusive of adhesive, can be expressed in pounds per square foot as:

$$W^* = W_f + W_v + W_x = W_f + \omega_v d_v N_v + 2 \omega_x d_x N_x / \sin \theta .$$

The name "Ideal Laminate" has been assigned not only because this laminate incorporates no weight penalty due to adhesive but also because the analysis of the mechanical properties is simplified in that there is no interaction between the components.

Real laminates must of course include an adhesive. This adhesive can be incorporated in three primary ways: (1) adhesive applied to the base film; (2) threads pre-coated with adhesive; and (3) adhesive applied to the threads in liquid form during the lamination process. This third process can be further subdivided into die coating, curtain coating, roller coating and other methods. All of the foregoing techniques have been used on FTL laminates.

For adhesive-coated film the real weight,  $W$ , expressed in pounds per square foot can be written as:

$$W = W^* + W_a ,$$

where  $W_a$  is the weight per square foot of the adhesive layer.

For adhesive coated threads, the adhesive weight has been found to be proportional to the thread denier and will vary with the coating process and of course the type of adhesive. In these cases the real weight,  $W$ , can be expressed as:

$$W = W_f + \alpha_v \omega_v d_y N_y + 2 \alpha_x \omega_x d_x N_x / \sin \theta$$

where the  $\alpha$  values are dependent upon both the coating processes and the thread denier and are determined empirically. If the same coating process and same denier threads are used for warp and fill directions, then:

$$\alpha = \alpha_x = \alpha_v$$

$$\omega = \omega_v = \omega_x$$

and

$$W = W_f + \alpha \omega (d_v N_v + 2 d_x N_x / \sin \theta).$$

For typical FTL laminates, we have the following:

$$W_f = 0.0072t \text{ (Mylar)}$$

$$\omega = 7.46 \times 10^{-8} \text{ lb/denier/ft (Dacron),}$$

where  $t$  is the film thickness in mils. For the precoated threads used in the NASA Voyager balloon program,  $\alpha$  was computed to be 1.006.

Figure B3 shows both a typical FTL laminate, reinforced with additional warp threads, in the center of the normal warp threads, and a "futuristic" laminate with the reinforcement pattern tailored to a hypothetical gore stress distribution for a balloon in the fully inflated state. Munson<sup>B1</sup> found this latter design feature to be cost ineffective for the intended scrim-balloon applications. I had already rejected use of this latter pattern on the basis that the stresses are far from uniform during ascent when the gores deploy and redeploy. The generator system for such stress-tailored patterns was never developed.

B1. Munson, J. B. (1969) Design and Manufacture of Composite Isotensoid Natural Shape Balloons, Final Report, Contract AF 19(628)-5987.

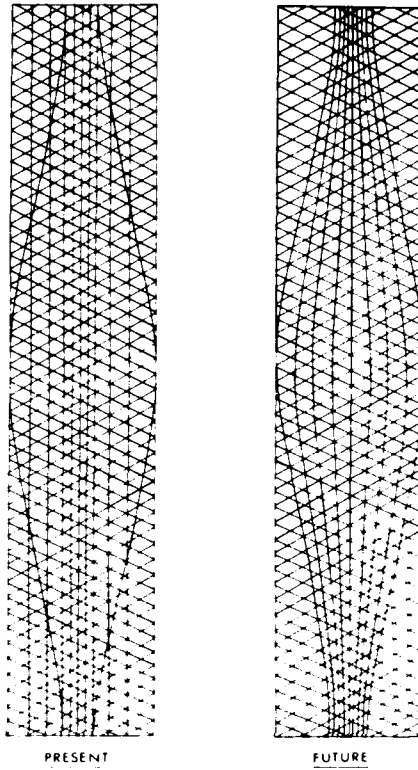

Figure B3. FTL Non-woven Gore Reinforcement Patterns. All material beyond the outer curves is excess and is trimmed off before assembly of gores into the balloon shell

## Appendix C

### Tandem Balloon Systems

Moroney<sup>C1</sup> in 1965 summarized what he considered to be the principal reasons for the development of the tandem balloon configuration (Figure C1) which used reinforced polyester for the construction of the balloon shell. Some of his reasons are included in the following list.

- (a) There was a need for higher gross lifts that exceeded the capabilities of both polyethylene balloons and existing dynamic launch platforms.
- (b) There was a need to eliminate or at least significantly reduce dynamic launch shock.
- (c) There was a requirement to launch when ground winds exceeded the operational limits for single cell polyethylene balloons.
- (d) There was a desire to study the deployment of large balloons under more uniformly loaded conditions with the objective of being able to inflate a large balloon without developing a large rudder of undeployed shell material.
- (e) There was a desire to inflate large balloons above the height of the tropopause near which many failures occurred.

---

C1. Moroney, R. D. (1966) Tandem balloon systems, Proceedings, AFCRL Scientific Balloon Workshop, 1965, Arthur O. Korn, Editor, pp. 65, 75, AFCRL-66-309, AD 634765.

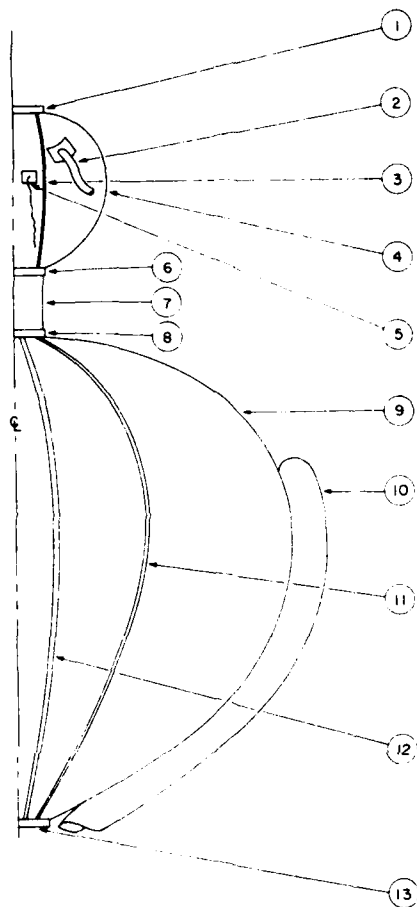

Figure C1. Half View of Tandem Balloon System. The principal launch balloon components include: (1) the apex fitting which contains the helium valve, (2) the inflation tube(s), (3) the helium valve cable, (4) the shell assembly-consisting of the gores, (5) steering patches to help control the balloon during initial inflation, and (6) the base end fitting assembly. Secured to the base end fitting assembly is: (7) the transfer duct. Below and secured to the transfer duct is the main balloon assembly, the principal components of which include: (8) the apex fitting which mates with the transfer duct, (9) the shell assembly, (10) the relief ducts to vent excess lift when entering float, (11) the helium valve cable, (12) the reefing sleeve to prevent the formation of a sail during the launch phase, and (13) the base end fitting to which the payload is secured.

As Moroney noted, the tandem configuration did meet the needs expressed in (a) through (c) above. However, the tandem configuration by its very nature (see Figure C2) precluded the very uniform crown deployment achievable from the moment of lift-off with fully tailored single cell balloons. Further, the nature of "tropopause bursts" was not fully understood to the extent that inflation of the main balloon above the tropopause would, with any certainty, eliminate the ascent burst problem. Further, although gas transfer has been successfully initiated at 40,000 ft, I have found no evidence of an attempt to begin main balloon inflation above the tropopause; such a system would require an eightfold increase in the usual launch balloon volume with a consequent fourfold increase in the launch balloon weight. A tandem system so configured would definitely preclude the ability to meet objective (c) (higher launch wind survivability) due to the excess of undeployed surface of the launch balloon at launch.

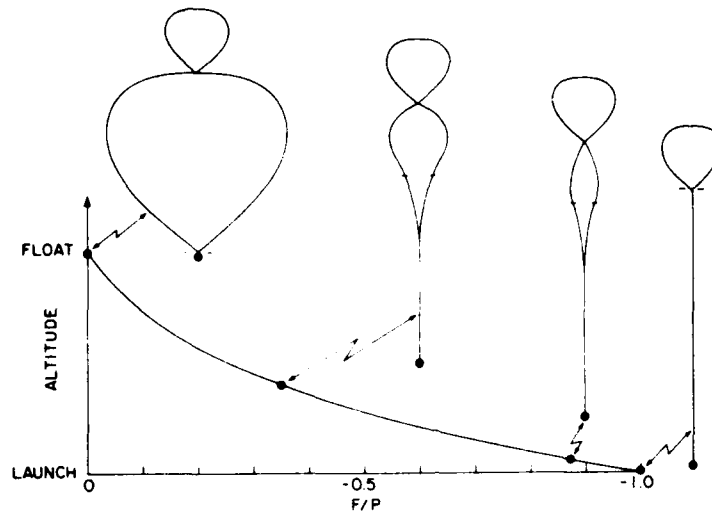

Figure C2. Variation of the Shape of a Tandem-Balloon System as it Ascends to Altitude. The short lines indicate the zero pressure level.  $F$  is the net upward force on the main balloon apex and  $P$  is the system payload

The launch balloon of the tandem system was normally sized to accommodate the gross inflation at about 10,000 ft above mean sea level. The tensile strength of the launch balloon material was based upon the combined effects of the suspended weight, main balloon plus payload, and the superpressure resulting from both the gas flowing through the transfer duct into the main balloon and the pressure head of the gas in the main balloon. The transfer process is explained graphically in Figure C3, taken from Moroney's paper and a detailed study of the relationships among the loads, pressures and stresses in a tandem system was conducted by Smalley.<sup>C2</sup>

The volume of the fully deployed main balloon of the tandem system, unlike a single cell balloon, must support more than the combined weights of the payload and the main balloon itself; it must also support the net weight of the launch balloon, after the system is above the altitude where the launch balloon would support its own weight.

C2. Smalley, J. H. (1968) Pressures and stresses in tandem - balloon systems, Proceedings, Fifth AFCRL Scientific Balloon Symposium, Lewis A. Grass, Editor, pp. 205, 216. AFCRL-68-0661, AD 685726.

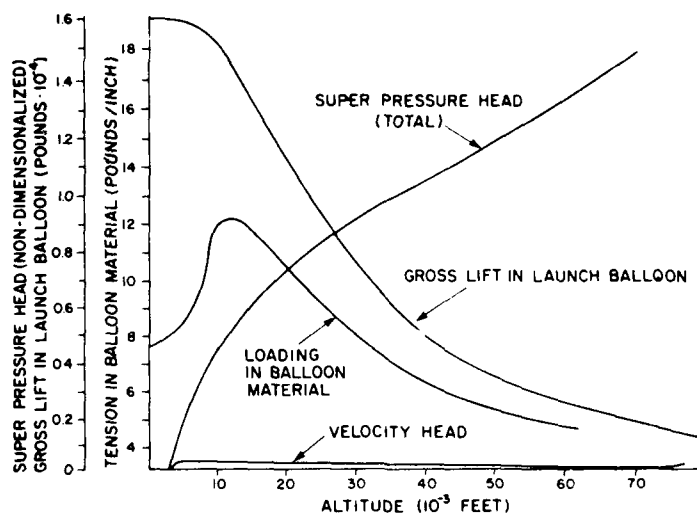

Figure C3. Stratoscope II Launch Balloon Gas Transfer

Figure C2 (previously referenced) and Figure C4 graphically show the transition from the full deployment of the gores through partial deployment of the gores and then back to full deployment as the inflatant is being transferred from the launch balloon to the main balloon, and the tandem balloon system moves from launch to float altitude. Figure C2 was prepared by Smalley from the results of computer-aided shape studies; it is related to the fundamental question of critical loading in the main balloon, a subject mentioned in the main text. Figure C4 provides quantitative experimental confirmation of the main balloon shape changes predicted by Smalley's studies.

Finally, Table C1 summarized some characteristics of the principal tandem balloon systems flown during the 1960's. Except for the CRISP system (which used commercially specified Mylar that was found retrospectively to have evolved primarily to support the magnetic tape industry) all of the systems were successful: the final and successful Viking program used a specially oriented Mylar and a carefully engineered fiber reinforcement pattern designed to accommodate possible shear stresses. This pattern problem was studied by Alexander,<sup>C3</sup> Alley,<sup>C4</sup> and

- C3. Alexander, H., and Agrawal, P. (1972) An Evaluation of Fiber Reinforced Films Used in High Altitude Balloons, Scientific Report No. 3, Contract F19628-69-C-0069, AFCRL-72-0235, AD 749880.
- C4. Alley, V. L., Jr. (1973) Analysis of a yarn reinforced laminate for balloons and other structural uses, Proceedings, Seventh AFCRL Scientific Balloon Symposium, George F. Nolan, Editor, pp. 415, 448, AFCRL-TR-73-0071, AD 767582.

Niccum,<sup>C5</sup> but Munson<sup>C6</sup> reported, in 1974, that tests of 0.3 mil Mylar reinforced by dacron fibers—to the extent of doubling the weight of the base Mylar—showed only slightly improved shear strength. Munson did report, however, that for reinforced polyethylene film, the shear capability increased in proportion to the added weight of yarn and adhesive. Lack of interest in large tandem systems at that time, and since, has made this later finding an historical obscurity.

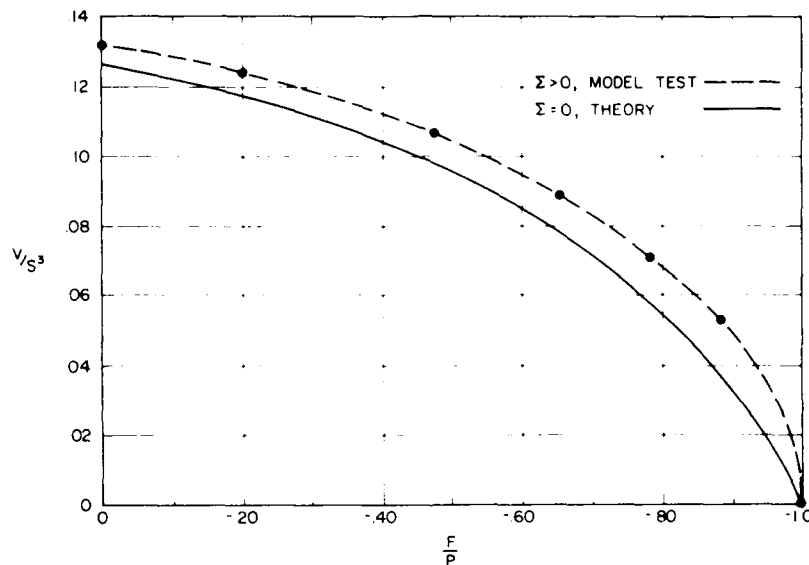

Figure C4. Comparison of Theoretical and Experimental Relationship Between Non-dimensionalized Main Balloon Volume and Ratio of Net Upward Force  $F$  on Main Balloon Apex and System Payload  $P$ .  $V$  is the instantaneous volume of the main balloon and  $S$  is the main balloon's gorelength. The test was conducted in the early 1960's in a hanger at Hanscom Field, Massachusetts. The correlation is excellent considering that the model's gorelength was less than 10 ft

- C5. Niccum, R. J. (1972) Comparison of polyester film-yarn composite balloon materials subjected to shear and biaxial loading, NASA Contract NAS1-10, 750, Report No. NASA CR-2047, p. 30.
- C6. Munson, J. B. (1974) Proceedings (Supplement), Eighth AFCRL Scientific Balloon Symposium, 30 September to 3 October 1974, Andrew S. Carten, Jr., Editor, pp. 211, 240, AFCRL-TR-74-0393, AD A003398.

Table C-1. Representative Heavy-Load Tandem Balloon Systems Made From Reinforced Mylar Film

System Reference	STRATOSCOPE II	PROJECT 770	NASA (ORMIES)	VOYAGER	CRISP	CRISP	VIKING
Launch Balloon Volume ( $\text{ft}^3$ ) <sup>1</sup> Material	252,147 (GT-12*)	254,134 (GT-12*)	324,119 (GT-1012-4†)	170,471 (GT-12*)	516,301 (GT-1012-4†)	514,721 (GT-1012-4†)	288,179 (GT-1012-4†)
Main Balloon Volume ( $\text{ft}^3$ ) Material	5,235,230 (GT-12*)	2,401,817 (GT-12*)	27,722,630 (GT-111-4)	25,997,739 (GT-111-1)	33,798,000 (GT-111-4)	37,386,000 (GT-119200)	34,637,088 (GT-127600)
Payload (lb)	10,235	10,433	8,475	3,606	13,809	11,904	5,947
Free Lift (lb)	1,373	1,284	1,519	1,140	3,294	2,530	1,375
Gross Lift (lb)	15,103	14,291	16,711	8,742	25,254	23,600	15,123
Loading (%) <sup>2</sup>	7.77	10.36	5.57	9.51	8.16	5.96	6.57
Performance	Success	Success	Success	Success	Failure	Failure	Success

<sup>1</sup> Volume for  $\Sigma = 0$ -Shape, ( $\bar{V} = 0.12605$ )

<sup>2</sup> Load at apex fitting of main balloon as a % of film strength, computed before release; at float it is about 1/3 higher

\* Leno weave

† Leno weave with warp reinforcement

**MED**  
**8**