

AD-A132 079

CONCEPTS FOR IMPROVING THE MILITARY CONTENT OF
AUTOMATED WAR GAMES(U) RAND CORP SANTA MONICA CA
P K DAVIS NOV 82 RAND/P-6830 SBI-AD-E750 769

1/1

UNCLASSIFIED

F/G 15/7

NL

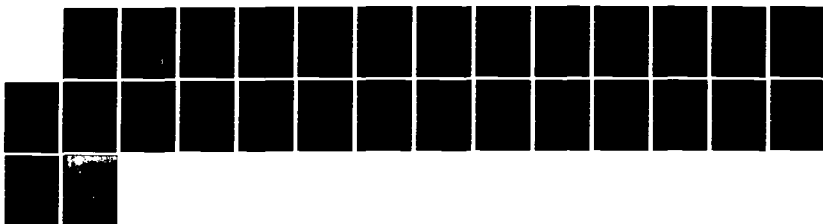

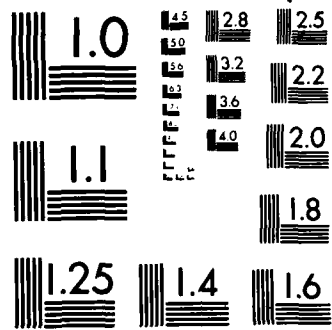

MICROCOPY RESOLUTION TEST CHART
NATIONAL BUREAU OF STANDARDS-1963-A

AD-A750169

(1)

ADA 132079

CONCEPTS FOR IMPROVING THE MILITARY CONTENT
OF AUTOMATED WAR GAMES

Paul K. Davis

November 1982

SEP 2 1983
S
A

OTIC FILE COPY

This document has been approved
for public release and sale; its
distribution is unlimited.

P-6830

The Rand Paper Series

Papers are issued by The Rand Corporation as a service to its professional staff. Their purpose is to facilitate the exchange of ideas among those who share the author's research interests; Papers are not reports prepared in fulfillment of Rand's contracts or grants. Views expressed in a Paper are the author's own, and are not necessarily shared by Rand or its research sponsors.

The Rand Corporation
Santa Monica, California 90406

CONCEPTS FOR IMPROVING THE MILITARY CONTENT
OF AUTOMATED WAR GAMES

Paul K. Davis

November 1982

PREFACE

This paper was prepared for an invited address at the Joint National Meeting of the Operations Research Society of America and the Institute of Management Sciences (San Diego, California, October 1982). The paper draws on work done earlier for the Director of Net Assessment in the Office of the Secretary of Defense through Defense Nuclear Agency Contract No. DNA001-80-C-0298.

1100
COPY
INSPECTED
2

Dist		
A		

SUMMARY

This paper describes one aspect of recent work in the Rand Strategy Assessment Center (RSAC), the challenge of finding ways to incorporate military realism in analytically oriented automated war games. Meeting the challenge has required developing new concepts and techniques that show great promise. The philosophy behind them has even greater applicability. One such concept is that of analytic war plans, logic structures attempting to capture the many high-level decision points that would be faced by the United States and Soviet Union in conflict. The analytic war plans are abstract rule-based generalizations of decision trees. The other concept treated in this paper defines an approach to combat modeling that sacrifices analytic elegance for pragmatism as part of a philosophy requiring the RSAC to treat numerous special phenomena of war that can have important implications even at the strategy level, but which have traditionally been ignored or poorly treated in analytic models.

ACKNOWLEDGMENTS

The author appreciates discussions with Andrew Marshall, who posed many of the challenges dealt with in this paper, particularly the controversial requirement to pay attention to certain important "special phenomena" of real wars that are more traditionally ignored as unmodelable. The validity of that requirement is undeniable, but the willingness to forget it has been almost universal except in certain war gaming activities used for training. The author also appreciates suggestions of Peter Stan, who read the paper in draft.

CONTENTS

PREFACE	iii
SUMMARY	v
ACKNOWLEDGMENTS	vii
FIGURES AND TABLES	xi
Section	
I. INTRODUCTION	1
The Rand Strategy Assessment Center (RSAC)	1
Basic Elements of the RSAC Automated War Gaming System ...	2
The Goal of Multiscenario Analysis	3
Conceptual Challenges in Building Up the Military	
Content of Automated War Games	5
II. THE CONCEPT OF ANALYTIC WAR PLANS	8
III. THE CONCEPT OF SCRIPTED MODELS	15
IV. CONCLUDING COMMENTS	18
REFERENCES	19

FIGURES

1. Move Sequence and Information Flow in an RSAC War Game	4
2. Decision Trees for a Simple Problem	10
3. Analytic War Plans as Portions of a Scenario Space	11

TABLES

1. Illustrative Special Phenomena	6
2. Illustrative Mappings of Phenomena to Models	17

I. INTRODUCTION

THE RAND STRATEGY ASSESSMENT CENTER (RSAC)

The Rand Strategy Assessment Center (RSAC) is an ambitious multiyear effort to improve the methods by which the United States analyzes and reviews military strategy for potential large-scale conflicts.* The RSAC program is the result of DoD initiatives late in the 1970s, initiatives largely influenced by the desire to imbed strategic nuclear analysis in a richer context than that permitted by the traditional "exchange calculation" approach.[3] As a by-product of the effort to build such a context, the RSAC can, in principle, treat a broad range of conflicts ranging from U.S.-Soviet confrontations in third areas to full-scale prolonged nuclear war. It will take several years to approach the RSAC's potential in this regard, but progress is now rapid. This paper describes one aspect of RSAC work during the last twelve months, the challenge of finding ways to incorporate military realism in automated war games.

As discussed early in the RSAC effort,[4] the concept of replacing the human teams of traditional war games with computer automatons holds out great promise. Indeed, it seems likely that only by such a procedure would it be possible to gain enough control over the variables of war games to permit reproducible, transparent, and rigorous multi-scenario analysis.

Rand demonstrated the feasibility of building an automated war game early in 1981, but the emphasis during that early period was on technical problems such as adapting artificial intelligence techniques to the war game challenge.[4] Although even the initial breadboard system had significant capabilities, especially for treating a variety of strategic nuclear phenomena with interactive modeling, everyone recognized that the system did not yet include a high degree of military content--especially with respect to theater conflicts. Since it was an explicit

* See Ref. 1 for a bibliography of existing and emerging RSAC publications. Reference 2 introduced many of the ideas here.

goal of the program to be able to "look at the performance of forces in a wide range of situations, from crisis to conventional theater war under the threat of strategic systems...to all-encompassing general nuclear war, with a protracted period of warfare that may ensue beyond the large exchanges,"[3] this limitation was severe indeed. Responding to the challenge has required us to develop new concepts and new techniques.[1,2] In some respects, they seem eminently logical and almost obvious. Nonetheless, based on discussions and arguments over the course of a year, it has become evident that however logical they may be, they are by no means obvious. Indeed, they go strongly against the grain of most traditional analysis.

BASIC ELEMENTS OF THE RSAC AUTOMATED WAR GAMING SYSTEM

Automated war gaming is an analytic approach with the same structure as classic war games, but with human players complemented by or replaced to a large extent by computer models acting as automatons or "agents." Thus, we refer to the "Red, Blue, and Scenario Agents," the automatons representing the Soviet Union, United States, and third countries, respectively. These automatons (or computer models, to be less pretentious but also less colorful) cannot, of course, be reliable predictors of national behavior--there are fundamental uncertainties that no amount of research can eliminate. Thus, we work with alternative national personalities, referring to Ivan 1 and Ivan 2, Sam 1 and Sam 2, etc.; similarly, we have rule sets for "reliable allies," "initially reluctant allies," etc. We program the various models in artificial-intelligence languages designed to maximize transparency of the rules by allowing the analyst to interrogate the system about the reason for an automaton's decision, and to have the system respond by displaying the relevant rules in an English-like language. If the analyst does not like a given rule, or has discovered a mistake, he can change the rule interactively.

A powerful feature of our approach, one that tends to distinguish artificial intelligence modeling from other forms, is the use of heuristic rules--i.e., individual rules that need not be part of a cosmic theory, and which may not even be universally valid. It has become

increasingly apparent to researchers in this area that one can often go farther faster using a heuristic approach than attempting to derive that cosmic theory first. [5,6,7]

In addition to Red, Blue, and Scenario, the RSAC system includes a Force Agent that keeps book on forces worldwide and describes the expected results of conflict upon demand. The Force Agent relies upon numerous individual combat models, many of which are currently being improved in a major effort led by Rand's Bruce Bennett. Figure 1 illustrates how an RSAC war game proceeds, and suggests by its form that Force Agent, unlike the others, does not make decisions. Rather, it is a service agent. In fact, one can look at Scenario Agent similarly. Scenario Agent does not describe third-nation behavior in the same detail as that provided by Red and Blue; instead, it essentially keeps book on the scenario context and adjusts that context as the game goes on in ping-pong fashion between Red and Blue. I prefer, however, to think of Scenario as a player.

RSAC war games employ human technicians and analysts who can intervene at any move in the game to correct glitches, overrule automatons, or provide unmodeled information. Usually, however, not much intervention is necessary; instead, the analysts explore issues by rerunning a game with different inputs. The result is a new scenario with new outcomes. Note that by contrast with traditional analyses, the scenario is an output rather than an input in RSAC war games. This means that an analyst wishing to have the RSAC system produce a canonical scenario must spell out a lengthy set of assumptions, and tune those assumptions until he gets the results desired. Because of this, we often refer to the automated war gaming as an assumptions trap. [4]

THE GOAL OF MULTISCENARIO ANALYSIS

There is another aspect of the RSAC system to address before we focus in on the military issues, and that is the RSAC's emphasis on multiscenario analysis. It is not our purpose to develop a computerized system for running individual war games, but rather to seek the capability to examine large numbers of war games to better analyze the adequacy of alternative forces and strategies. This is a fundamental departure from traditional analysis, which emphasizes "best estimate" planning

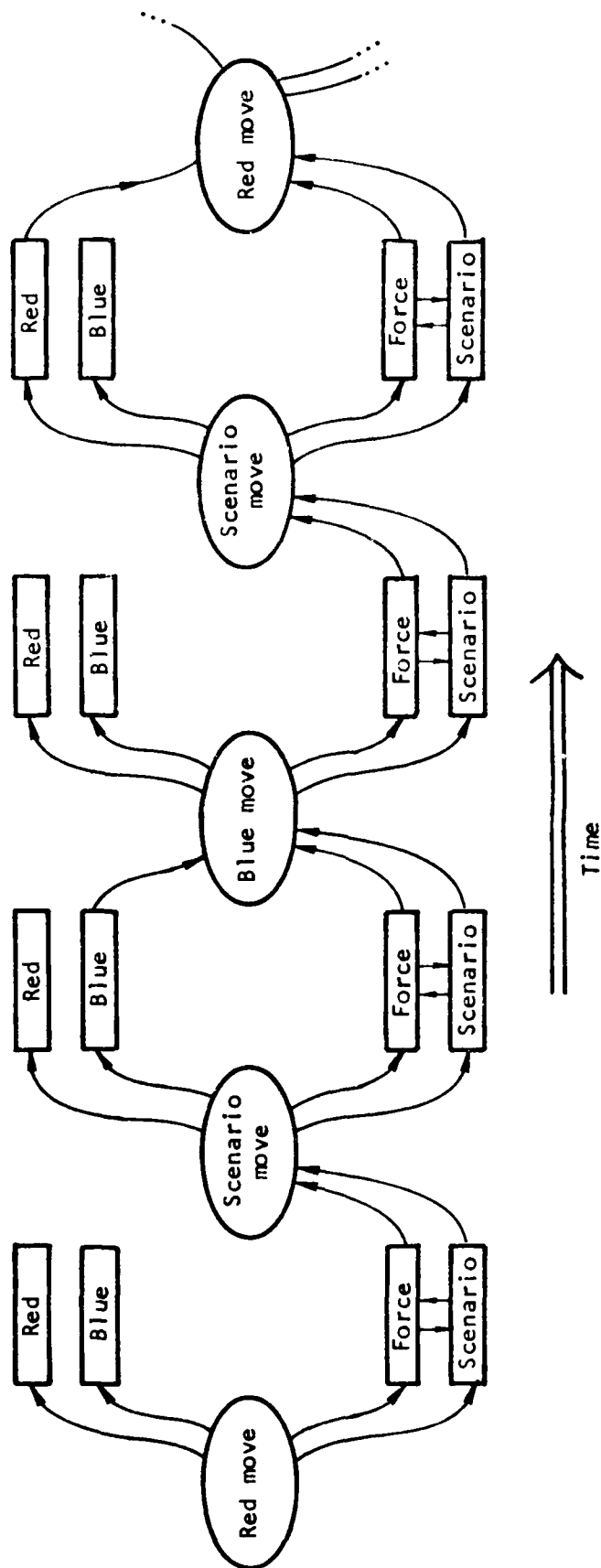

Fig. 1 - Move Sequence and Information Flow in an RSAC War Game

factors and specifies one or a very few planning scenarios at the outset. In our approach, we want to address uncertainties in such variables as: (1) Soviet behavior, (2) U.S. behavior, (3) third-country behavior, (4) force levels, (5) strategies, (6) details of initial setting, and (7) outcomes of certain types of key battles. How one might hope to digest and make use of the data from such multiscenario studies is a very difficult issue, and one that I will not discuss further in this paper.*

CONCEPTUAL CHALLENGES IN BUILDING UP THE MILITARY CONTENT OF AUTOMATED WAR GAMES

Given this background on the RSAC and its objectives, let us now turn to the subject of this paper: achieving military realism. Consistent with our strategy-level orientation and our desire to use the war gaming approach to introduce military realism, we have departed from conventional approaches to force modeling and balance assessments-- which tend to emphasize targeting and stereotyped attrition battles--by focusing on such matters as:

- o Military and political objectives.
- o Options for strategy and grand tactics.
- o Combined-arms aspects of warfare.
- o The constraints imposed by ever-changing political factors.
- o The likely and possible timelines of alternative campaigns.
- o Real-world inefficiencies in decisionmaking.
- o The many uncertainties regarding national behaviors, technical performance of systems, and the nature of modern war.

Although all military analysts are presumably concerned with most of the above, the structure of traditional analysis has not really allowed proper treatment. Remedying this is our first challenge.

The second problem is that there has been a systematic tendency to ignore altogether a broad range of special phenomena that do not lend

* See, however, Ref. 1 for some discussion.

themselves well to ordinary modeling, but which are extremely important in real wars. These include both special events such as sabotage of a critical command and control link and special types of combat for which standard firepower-oriented models fail. Table 1 lists some of these phenomena.

Table 1 reminds us that a substantial part of real warfare is not captured well in ordinary modeling. Moreover, there is usually no effort to capture such critical aspects as the relative morale of forces or the quality of leadership. Although it is often reasonable to

Table 1

ILLUSTRATIVE SPECIAL PHENOMENA

<u>Phenomenon</u>	<u>Tactic</u>
Selective attacks on C ³ I (e.g., antisatellite weapons)	"Strategic" use of airborne forces
Surprise and deception in theater warfare	Terrain and weather constraints
Ad hoc reconstitution of C ³ I	Shock effects of nuclear weapons
Rear area disruption by special operations team	Shock use of chemicals
Breakthroughs achieved by stealth and shock rather than by average firepower	Distributed defense in urban
Reconstitution of strategic nuclear forces in an extended war	Mountain warfare
Special tactics undercutting a whole class of opponent systems (e.g., underflying SAM radars).	War widening tactics

rationalize away such issues in performing analysis--especially analysis regarding long-lead-time force procurement or operations plans for some distant future--it would not be appropriate to do so in an approach that attempts to look at large numbers of scenarios and to measure the effectiveness of forces and strategies under many different circumstances.

In summary, then, there were two major conceptual challenges facing us early this year that involved the military content of the approach: how to structure the RSAC system so as to focus on strategy-level considerations such as objectives, uncertainties, etc.; and how to account for a broad range of phenomena that are usually swept under the rug.* Although we have no panacea, the approach we have developed depends heavily on constructs we call: (1) analytic war plans, and (2) scripted models. These are the subjects of Secs. II and III.

* In addition, we had the interesting and difficult task of developing a comprehensive game-serving complex of individual combat models that could be used interactively, and that would reflect the interrelationships among different force types and events in different theaters. That challenging problem, and development of the associated Campaign model, is a major element of our planned work in 1983. See Refs. 1 and 2 for a preview.

II. THE CONCEPT OF ANALYTIC WAR PLANS

In principle, it might be possible to develop computer models for Red and Blue that would develop their own strategies from statements of objectives and constraints. Realistically, however, it will probably be some time before useful models of that sort exist--except in treating simple problems.* Because of our desire to work realistic problems early in the RSAC's development, we concluded:

For now and some time into the future, it is more practical to have human experts identify the alternative strategies and grand tactics that the United States and Soviet Union might employ in a variety of campaigns.

This followed from a fundamental hypothesis[2] that it is possible for teams of military experts to do quite a good job in laying out alternative campaigns because in a real war the higher-level options are highly constrained by factors such as geography, limitations of road and rail networks, planning conservatism rooted in concerns about the fog of war upsetting more intricate plans, force levels, and other factors. Usually, war planners consider a broad range of different strategies and higher-level tactics, but then discard all but a few. For the purposes of RSAC work, we ask merely that nothing sensible be discarded. To be sure, we want to exclude strategies that are technically infeasible or unequivocally out of character for the player in question (even this is treading on dangerous ground), but we want to consider the consequences of many alternatives--most definitely to include controversial ones, such as those allowing the Soviets to do something unusual with high payoff.

* An example of a simple problem is allocating strategic nuclear weapons to a range of targets in an attempt to maximize value destroyed, with a secondary goal of minimizing throw-weight expended and a few constraints such as limits on the number of RVs per target, etc. There are straightforward computer routines for solving this allocation problem. By contrast, it is much more difficult to develop a realistic SIOP because of the proliferation of operational constraints, some implicit goals, and organizational factors. In practice, analysts use heuristic rules to force allocations to be more sensible when results of model allocations are challenged.

Unfortunately, any attempt to hold on to numerous alternatives immediately leads to an exploding decision tree. As a consequence, past strategy analysis has made little use of such constructs. In the RSAC's work, however, and with modern computers, there is no reason to shrink away from a proliferation of possibilities. To explain how we approach the problem, consider first the highly simplified decision tree in Fig. 2. This is based on a notional world in which there are only three countries: Red, Blue, and X. Red is considering invading X, and has precisely two war plans from which to choose. His principal concerns are whether Blue will intervene; whether, if Blue intervenes, Red can win the particular key battle; and whether, if Red wins that battle, Blue will escalate to a stylized nuclear war. Although this world is extraordinarily simplified, it suffices for the purpose of defining terms and concepts.

Figure 3 shows how the decision trees can be broken up into parts depending on key decisions. There are a number of possible paths for the scenario to take as a function of initial decisions and subsequent events, but all are captured by the decision tree--i.e., the tree defines the "scenario space." At the outset, Red can choose among the three analytic war plans, which represent alternative strategy-level options. Choosing an option or war plan does not determine the resulting scenario, however, because the scenario that unfolds depends on what happens at several subsequent branch points involving Blue decisions, acts of God, etc. Note that if Red were already farther through the scenario--say, in a situation in which he had invaded "Fast," Blue had intervened, and Blue had won the key battle--then Red would consider his subsequent scenario space to have two strategic options or analytic war plans: escalate to nuclear weapons, or not.

It is easy to see that the information content of the decision trees in Fig. 2 can be captured by a set of rules in a computer program. One does not "draw the tree" in the computer, but rather writes a set of rules, such as: IF Red decides to invade, THEN his invasion plan will be either "Fast" or "Slow." The details of the two plans must then be defined in the program. This might include mobilization time, order of

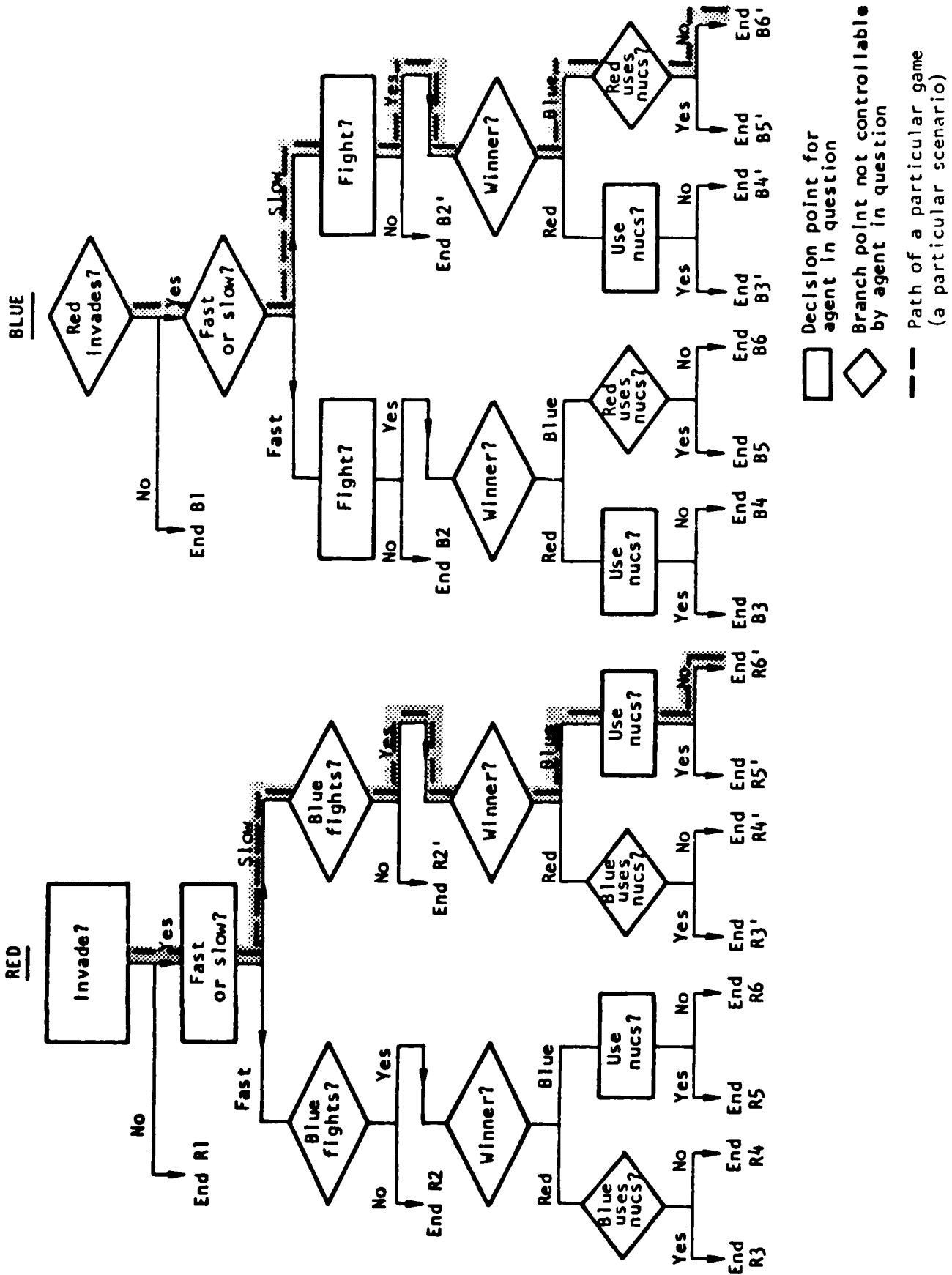
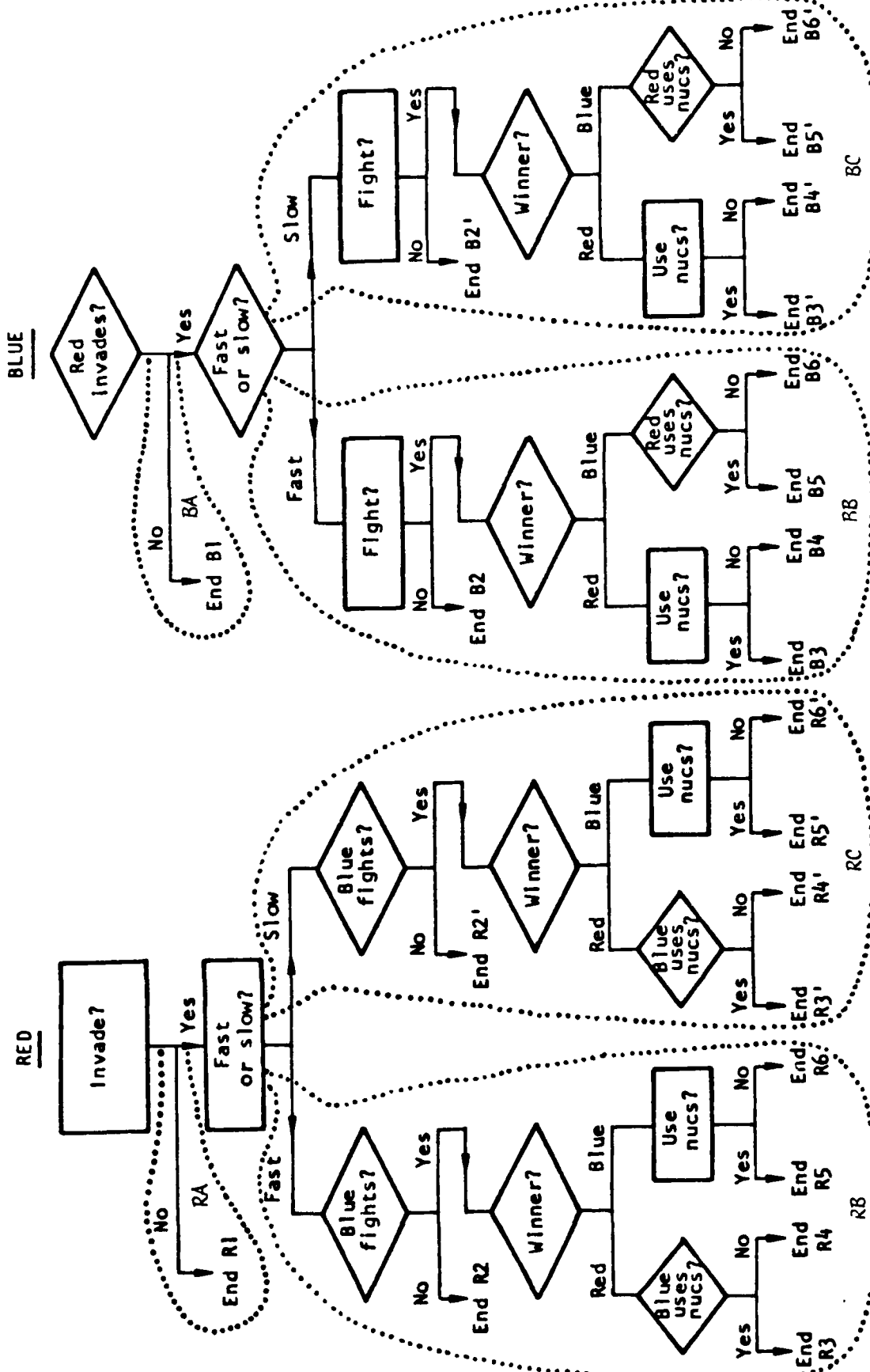

Fig. 2--Decision Trees for a Simple Problem



Decision point for agent in question
 Branch point not controllable by agent in question
 RA, RB, RC, BA, BB, BC: analytic war plans

Fig. 3--Analytic War Plans as Portions of a Scenario Space

battle, timelines for the various intermediate objectives, etc. The reason for stressing this seemingly obvious point is that even in the simplified world to which Fig. 2 applies, a little complication would immediately make the drawing of decision trees unpleasant, impractical, or impossible. Suppose, for example, that we wanted to generalize the problem in only one way: giving Red and Blue the opportunity to use nuclear weapons at every game step previously identified. We could draw the corresponding tree, but it would be more unpleasant. Now suppose that we wanted to generalize by giving Red the right to tune his invasion plan continuously--i.e., by choosing whatever mobilization time he desired. At this point, we could no longer draw a classic decision tree because there would be a continuum of options.* To the computer, however, there is no problem. We merely write the rules accordingly. I might add, also, that once again the heuristic approach is useful: we can begin with simple decision trees, translate them into rules, and then expand the number of branches as we gain experience and wisdom--we need not begin with a comprehensive image of all the options.

It follows, then, that in RSAC work we use abstract rule-based generalizations of decision trees to define the "scenario space" for our war games. When they are simple enough, our intuition allows us to predict reasonably well what will happen in a given war game if we know the rules and the initial conditions. In more complex situations, however, it becomes increasingly difficult to appreciate intuitively the implications of alternative initial conditions or rules.

Analytic war plans correspond to strategy-level options; they may involve top-level strategy choices, or choices among "grand tactics" (e.g., whether to use airborne forces hundreds of kilometers behind the lines, or whether to mount an Inchon landing with its associated risks). Clearly, specifying decisions at this level is not sufficient. To make full use of the approach, we associate with each analytic war plan a more detailed "branched script" that provides a higher-resolution view of the situation. For example, a branched script for an analytic war plan calling for an invasion would specify orders of battle, mobilization

* One could, of course, break the continuum up into pieces, but the decision tree might be very bushy and unpleasant.

times, etc. The branched script would have decision and other branch points in addition to those required by the top-level analytic war plan structure. Again, in implementing the approach, we insert the requisite information in the form of rules, equations, etc. We do not "draw" the branched scripts.*

Interested readers can refer to Refs. 1 and 2 for more details, and there will be several publications over the next year describing our refined views on the matter. Suffice it to say, we have adopted the war plan approach to automated war gaming because it allows us to assure that even early applications of the system can incorporate the types of information military experts and intelligence experts can provide. The method has enormous growth potential and should seem relatively natural to war planners once they become used to it.

The typical reactions of skeptics center around three questions: How is the method different (after all, other workers have used decision trees for scenario analysis)? How flexible is the method--aren't we hardwiring things we ought instead to let the computer optimize? Also, how feasible is it to be "complete?"** Let me touch on these only

* The term "branched script" is motivated in part by the artificial intelligence technique we have used for Red and Blue decisionmaking. The meaning is the obvious one: a script lays out the story line, without necessarily filling in all the details (some of which must be worked out by the Force Agent based on the detailed circumstances of conflict). See Ref. 5.

** An additional concern is sometimes expressed: Aren't we merely going to get out what we put in? Won't the game-generated scenarios be obvious consequences of the decision tree, rule-based or not? My response can only be that we have a choice: We can build a creative system that produces random results that may be creative and fun, or we can build a system that produces reproducible results based on rigorous procedures and transparent assumptions. It is the latter we need for analysis. Entertainment might be a different matter. As an aside, however, I can assure the reader that the scenarios spun out by the RSAC system are not easily predictable except to those individuals closest to the programming--and even to those for only a short time. The number of variables and interrelationships is far more than can be handled conveniently by the human intuition. By the way, Euclid's geometry can be regarded as having no more content than its axioms and definitions--i.e., the theorems are mere tautologies.

briefly. First, it appears that the method is quite different from past efforts--the decision tree approaches we are familiar with are superficial and inflexible in their treatment of war.* Second, there is no question but that we are limiting the scope of the analysis and its flexibility. Indeed, that was the intention--I did not want early generations of the system to be spitting out large numbers of ingenious but utterly unrealistic scenarios. To repeat, I believe that in the real world, options at the strategy level are moderate in number--even to creative military leaders. Furthermore, the generality of the approach can be increased by evolution: by adding branches as one finds them, and by replacing hardwired numbers in the branched scripts by algorithms that allow the computer to do some local goal-directed optimizations comparable to what would be accomplished in the field.** As for completeness, I would point out that we do not have to treat all scenarios to measure the validity of our strategies and forces; rather, we need only to consider an adequately complete set of scenarios--i.e., a representative sample. For the purposes of discussion among friends, there are numerous analogies to the "complete sets" of linear algebra; however, the analogies are a bit sticky to elaborate upon.

* Although some of my colleagues and I are "closet decision-theory types," persuaded by the logic of Howard Raiffa's well-known book, Decision Analysis (Addison, Wesley, 1968), it does not currently seem desirable to program the various agents to assign utilities and work decision-theory problems a la Raiffa. Instead, it appears that realism requires that national decisions be based on less rigorous and less "rational" rules. We hope to explore this theoretical issue more deeply.

** As discussed in Refs. 1 and 5, we are using goal-directed programming for the decisionmaking of the Red and Blue Agents relevant to mid- and lower-level issues such as allocation of forces among axes of advance, tuning of timelines, etc. Doing so is essential, because the alternative would be to work out details of every possible war plan in advance--the effect of which would be to greatly limit the number of cases treated.

III. THE CONCEPT OF SCRIPTED MODELS

As discussed in Sec. I, one of our major challenges has been to incorporate in our war games many of the special phenomena that analysts usually sweep under the rug. We must be very selective in doing so, because an attempt to treat all of them at all times would immediately prove both impossible and undesirable--it would merely clutter the landscape with noise. Nonetheless, we must take some of them into account, at least in performing sensitivity analyses, and in some cases as part of our "best estimate" work. The principles in doing so appear to be the following:

- o Leave nothing out that might have a major effect at the strategy level.
- o Focus on consequences of the special events rather than on the details of how they arise.
- o If good simulation models don't exist, construct simple models that describe what the best experts available think might happen. Call these "scripted models" if they cannot be related to simulation models.*

There is nothing mysterious or innovative about what we call scripted models--at least not on an individual basis. Apparently, however, it is both unusual and against-the-grain to insist on using scripted models wherever there are important effects that are not ordinarily modeled. Our position, of course, is that to ignore the

* In this paper I use the term "simulation model" to mean models in which cause and effect are related by expressions with some basis in the microscopics of the problem. For example, a model estimating the penetration capability of bombers in terms of SAM radar characteristics, the number of interceptor aircraft, etc., would usually be a simulation model. If, by contrast, we say, "Well, air interdiction would probably slow up ground movements by a week or two, or even three," then we have the basis for a scripted model that says, "Delay Time = 2 weeks (1 or 3 in excursions)." With additional research, one might be able to improve the scripted model and have it plausibly dependent on the level of interdiction or other factors; with even more research, it might begin to approximate a legitimate simulation model.

effect is equivalent to saying that the best estimate is that there is no effect.

Table 2 illustrates our general approach to "special phenomena," an approach that requires: (1) deciding which phenomena to treat, and when; (2) identifying their significance to a broad range of operations; and (3) establishing mappings within the Force Agent's models to reflect that significance. Using the second example from Table 2, note that if we are told to be concerned about covert agents in the United States who, in a strategic crisis, might attack ground stations for our early warning system, we could first arrange to have some of the RSAC war games include successful attacks of such types. In such games we would want to see effects on warning time for bombers, ICBMs, and the NCA. This, in turn, could affect bomber, ICBM, and NCA survivability. Both bombers and the NCA could be destroyed by SLBM attacks, and launch under attack might not be feasible for ICBMs. To implement such an effect, we must, of course, construct combat models relating Launch Under Attack effectiveness to warning time and alert status, and do similarly for the other parts of the problem. Since the phenomena in question (agent attacks) are very difficult to assess, we can do no better than to parameterize their effectiveness, and to be sure that the other models are appropriately sensitive to the degree of effectiveness. Note, for example, that other early warning systems exist, and that ground stations will be redundant later in the decade.

To summarize, then, our approach in RSAC analysis is to take seriously a broad range of "special phenomena." When good models do not exist, or are infeasible, we will rely upon "scripted models" which are unabashedly parametric and unabashedly based on the best available expert judgments. Where possible, we will use detailed models and traditional war gaming to better develop those judgments.* We anticipate

* It would be only natural to draw from Donald Blumenthal's work with the JANUS system at the Lawrence Livermore National Laboratory and to reflect some of his conclusions in RSAC work--not by coupling the computers together, but by drawing inspiration from the more detailed work. The JANUS system represents state-of-the-art microscopic simulation--using, for example, digital representations of actual terrain in Europe, and allowing users to test doctrinal procedures for emplacing TOWs, tanks, etc., in a variety of actual European settings.

Table 2

ILLUSTRATIVE MAPPINGS OF PHENOMENA TO MODELS

<u>Phenomenon</u>	<u>Significance</u>	<u>Implementation in Models</u>
Special-operation units destroy specialized cranes in Persian Gulf port.	Some ships cannot unload. Others must use "Over the Shore" logistics.	Increase unload time for some ship classes, and allow time for others to transfer cargo to amphibious ships in Saudi Arabia (i.e., add standard delay times dependent on ship class.)
Covert in-place agents in United States and allied countries destroy ground stations of early warning satellite systems (DSP).	Reduces warning time for bombers, ICBMs, and NCA. Degrades BMD systems. Affects Blue Agent attitudes.	Decrease bomber prelaunch survivability, especially against SLBM attacks; initiate airborne alert and associated degradation-with-time models if appropriate; decrease likelihood of successful launch under attack except for first days after loss of ground stations.
Surprise early Pact penetration on Central Front (faster-than-anticipated massing of forces).	May allow devastating Pact breakthrough.	Allocate Soviet forces among axes of advance consistent with a surprise breakthrough attempt. Start land-warfare models and test NATO ability to contain Soviet penetration.

that this philosophy will have a dramatic effect on our work, because a large fraction of conventional combat modeling cannot now be described well by simulation models. For our purposes, we reject the usual modeling practice, which is to use existing models even when they are known to give silly results. Moreover, we reject the common but implicit practice of turning cartwheels to make inappropriate complex models give reasonable answers. Our fudge factors and assumptions will be as explicit as we can make them.

IV. CONCLUDING COMMENTS

We now have significant experience in attempting to use the ideas described in this paper.[1] It appears that they are straightforward to implement, but, as expected, demand substantial research and preparation time prior to actual war games. It could hardly be otherwise, since there generally seems to exist in nature something akin to a conservation-of-difficulty law.* Military analysis and strategic thinking generally are not, and will never be, simple. The uncertainties are legion and the number of variables large. Nonetheless, it appears that the approach will be fruitful, and that--as predicted--even initial applications will have value. In the longer run, as we begin to go beyond what expert intuition can handle, I believe the approach could have profound consequences for our understanding of strategic war and the role of strategic weapons, and for other applications ranging from operational planning to policy-level decisions on strategy options for the peacetime competition.

* In economic circles, this appears as "There is no free lunch."

REFERENCES

1. Davis, Paul K., and James A. Winnefeld, "The Rand Strategy Assessment Center: An Overview, and Interim Conclusions About Potential Utility and Development Options," The Rand Corporation, R-2945-DNA, forthcoming.
2. Davis, Paul K., and Cindy Williams, Improving the Military Content of Strategy Analysis Using Automated War Games--A Technical Approach and an Agenda for Research, The Rand Corporation, N-1894-DNA, June 1982.
3. Marshall, Andrew, "A Program to Improve Analytic Methods Related to Strategic Forces," Policy Sciences 15, 1982.
4. Graubard, Morrie H., and Carl H. Builder, New Methods for Strategic Analysis: Automating the Wargame. The Rand Corporation, P-6763, April 1982; also submitted to Policy Sciences.
5. Steeb, Randall, and James Gillogly, "Design for an Advanced Red Agent for the Rand Strategy Assessment Center," R-2977-DNA, forthcoming.
6. Jones, William, Jean LaCasse, and Mark LaCasse, "The Mark II Red and Blue Agent Control System for the Rand Strategy Assessment Center," The Rand Corporation, N-1838-DNA, forthcoming.
7. Schwabe, William, and Lewis M. Jamison, "A Rule-Based Policy-Level Model of Nonsuperpower Behavior in Strategic Conflicts," R-2962-DNA, forthcoming.

END

FILMED

9-83

DTIC