

AD-A132 162

EVALUATION OF STRESS CORROSION CRACKING CHARACTERISTICS
OF SELECTED FASTE. (U) AIR FORCE WRIGHT AERONAUTICAL
LABS WRIGHT-PATTERSON AFB OH N R ONTKO JUN 83

1/1

UNCLASSIFIED

AFWAL-TR-83-4028

F/G 11/6

NL

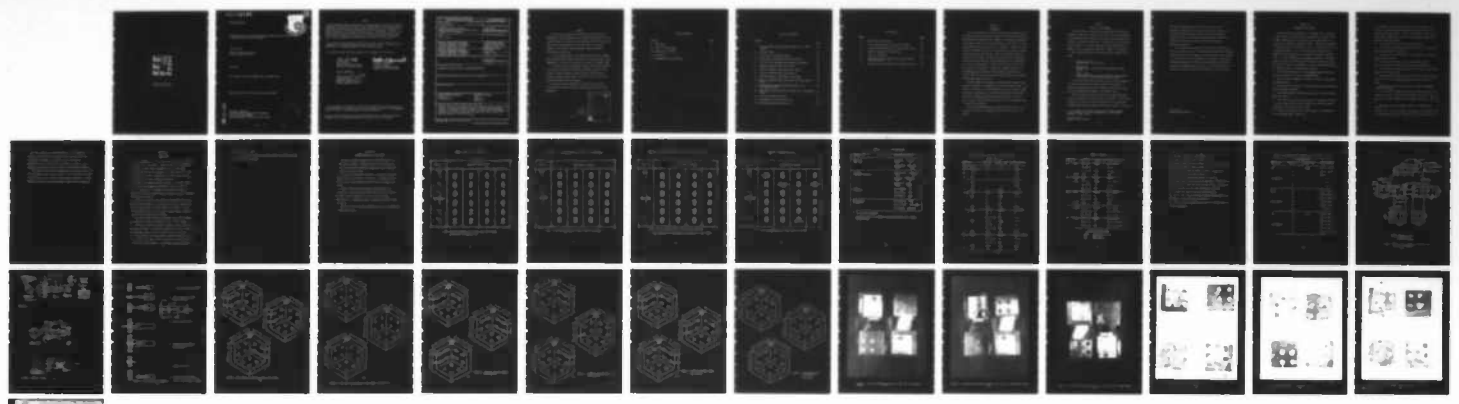

END
FILMED



MICROCOPY RESOLUTION TEST CHART
NATIONAL BUREAU OF STANDARDS-1963-A

ADA 132162

AFWAL-TR-83-4028



EVALUATION OF STRESS CORROSION CRACKING CHARACTERISTICS OF SELECTED FASTENER SYSTEMS IN 7075-T6 ALUMINUM

Neal R. Ontko

Materials Engineering Branch
Systems Support Division

June 1983

Final Report for Period November 1981 - November 1982

Approved for public release; distribution unlimited

DTIC FILE COPY

MATERIALS LABORATORY
AIR FORCE WRIGHT AERONAUTICAL LABORATORIES
AIR FORCE SYSTEMS COMMAND
WRIGHT-PATTERSON AIR FORCE BASE, OHIO 45433



83 09 06 012

NOTICE

When Government drawings, specifications, or other data are used for any purpose other than in connection with a definitely related Government procurement operation, the United States Government thereby incurs no responsibility nor any obligation whatsoever; and the fact that the government may have formulated, furnished, or in any way supplied the said drawings, specifications, or other data, is not to be regarded by implication or otherwise as in any manner licensing the holder or any other person or corporation, or conveying any rights or permission to manufacture use, or sell any patented invention that may in any way be related thereto.

This report has been reviewed by the Office of Public Affairs (ASD/PA) and is releasable to the National Technical Information Service (NTIS). At NTIS, it will be available to the general public, including foreign nations.

This technical report has been reviewed and is approved for publication.



NEAL R. ONTKO
Engineering and Design Data
Materials Engineering Branch

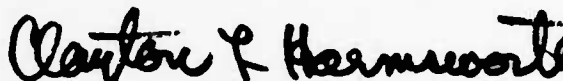

CLAYTON L. HARMSWORTH
Technical Manager
Engineering and Design Data
Materials Engineering Branch

FOR THE COMMANDER:

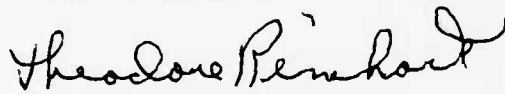

THEODORE REINHART, Chief
Materials Engineering Branch
Systems Support Division

"If your address has changed, if you wish to be removed from our mailing list, or if the addressee is no longer employed by your organization please notify AFWAL/MLSE, W-PAFB, OH 45433 to help us maintain a current mailing list".

Copies of this report should not be returned unless return is required by security considerations, contractual obligations, or notice on a specific document.

PREFACE

This report was prepared by the Materials Engineering Branch (AFWAL/MLSE), Systems Support Division, Materials Laboratory, Air Force Wright Aeronautical Laboratories, Wright-Patterson Air Force Base, Ohio, under Program Element 62102F, Project 2418, "Metallic Structural Materials", Task 241807, "Systems Support", Work Unit 24180703, "Engineering & Design Data".

The work reported herein was performed during the period November 1981 to November 1982, under the direction of the author, Neal R. Ontko (AFWAL/MLSE). The report was released by the author in November 1982.

The author wishes to acknowledge and thank the following companies for technical assistance and donations of hardware (fasteners, nuts, sleeves): Deutsch Fastener Corporation, Fatigue Technology Inc., Hi-Shear Corporation, PB Fastener, a division of Paul R. Briles Inc., and Kaynar/Microdot Fastening Systems.

Assistance was also rendered by the "Corrosion Control and Non-Destructive Evaluation" group of the Materials Integrity Branch, AFWAL/MLSA.

iii/iv



Accession For	
NTIS GRA&I	<input checked="" type="checkbox"/>
DTIC TAB	<input checked="" type="checkbox"/>
Unannounced	<input type="checkbox"/>
Justification	
By _____	
Distribution/	
Availability Codes	
Dist	Avail and/or Special
A	

TABLE OF CONTENTS

SECTION	PAGE
I Background	1
II Details of Test Program	2
III Observations and Results	4
IV Conclusions	7
V Recommendations for Future Work	9

LIST OF ILLUSTRATIONS

FIGURE	PAGE
1. Stress corrosion blocks and hole locations, 7075 - T6510 material.	19
2. Fastener Systems	20
3. Split Sleeve Cold Expansion System	21
4. Cold Work/Hi-Lok Specimens (Bare) Final Results	22
5. Cold Work/Hi-Lok Specimens (Shot Peened) Final Results	23
6. SLEEVbolt Specimens (Bare) Final Results	24
7. SLEEVbolt Specimens (Shot Peened) Final Results	25
8. Taper-Lok Specimens (Bare) Final Results	26
9. Taper-Lok Specimens (Shot Peened) Final Results	27
10. Taper-Lok Specimens Before Test "Bare" Top, "Shot Peened" Bottom	28
11. Cold Work/Hi-Lok Specimens Before Test "Bare" Top, "Shot Peened" Bottom.	29
12. PBF SLEEVbolt Specimens Before test "Bare" Top, "Shot Peened" Bottom.	30
13. Taper-Lok Specimens After Test	31
14. Cold Work/Hi-Lok Specimens After Test	32
15. PBF SLEEVbolts Specimens After Test	33

LIST OF TABLES

TABLE		PAGE
1.	Taper-Lok Head Protrusion	10
2.	HI-Lok Specimens after Cold Work and Post Ream	11
3.	Hole Diameters Before Cold Work (spit sleeve system)	12
4.	SLEEVbolt Specimens (Hole Diameters)	13
5.	Level of Interference	14
6.	ASTM G-44 Alternate Immersion Test 3.5% NaCl Results "Bare" Blocks only	15
7.	ASTM G-44 Alternate Immersion Test 35% NaCl conclusions	18

SECTION I

BACKGROUND

This effort evaluated the stress corrosion cracking characteristics of selected fatigue rated fastener systems in 7075-T6 extruded aluminum. By performing an evaluation of this nature a more complete assessment of the fastener system's total overall performance can be drawn. A fatigue rated fastener system loses some of its' advantage if undesirable stress corrosion characteristics result from residual stress patterns inherent with that particular system's use. Three very different systems were selected for this study. The Taper-Lok fastening system, reported to have several unique attributes, was chosen because of its broad-based use in the aircraft industry. A second system, which is used on the A-10 aircraft and elsewhere, incorporates a standard Hi-Lok pin in a cold worked hole (tapered mandrel pulled through a removable split sleeve). Both of the above are known to enhance fatigue lives (dynamic loading) when properly installed.

The PBF SLEEVbolt was selected as a third candidate system. This system is comprised of a tapered pin and internally tapered sleeve. The outside of the sleeve is straight shanked as the pin and captive sleeve are meant to be installed in a conventionally drilled or reamed hole. All fastener systems were pressed into the test blocks on an arbor press. Kaynar 3/16" KFN 600-3 nuts torqued to 30 inch pounds were used to complete the assemblies.

The test blocks themselves were separated into two groups - one group was left "bare", as machined, while the second group was shot peened.

SECTION II
DETAILS OF TEST PROGRAM

All test blocks were machined to specifications from 7075-T6510 extruded aluminum stock. One half of all test blocks were shot peened to an Almen intensity of 0.008 to 0.010 using a shot size equivalent to MI 230 at a coverage of 200 percent. The dimensions for the blocks are the same as used in a previous study performed by Lockheed-California Company (Calac) and detailed in Report No. LR 28554 . See Figure 1*

The following parts were installed "dry" in both groups of test blocks:

1. Taper-Lok 3TL-13-3
Cadmium plated, alloy steel pins.
2. PBF SB 110-3
KALGARD coated, alloy steel pins w/aluminum alloy 2024 sleeves.
3. Hi-Lok HL 221-6
Cadmium plated, alloy steel pins after 3.5% cold expansion using a split sleeve (removed) and Mandrel system.

All fasteners were 100° flush head type pins (Hi-Lok and PBF were full tension heads; Taper-Loks were reduced or shear heads). As previously stated Kaynar KFN 600-3 aluminum nuts were torqued to 30 inch-lbs to complete the assemblies. See Figures 2 and 3.

The intent which governed this effort was to keep interference levels and individual hole sizes essentially equivalent. Taper-Lok and Hi-Lok pins, 2nd "oversize", were selected for use as the 3/16" PBF SLEEVbolts were larger in diameter than regular or "nominal" size parts.

1. R.S. Kaneko, "Stress Corrosion Testing of Fastener Systems", Lockheed California Co., Report LR28554 dtd April 1978 Burbank, California 91503, 1978.

Figures begin on page 19.

Resultant interference levels are as shown in Table. Hole diameters and head protrusion are given in Tables 1 through 4. All hole surface and countersink finishes were of very good quality (125RMS or better). No flawed holes were observed. Installation procedures for each of the systems met with the respective manufacturers approval.

All test blocks were then placed in an alternate immersion tank filled with 3.5% salt water. Test procedures from ASTM G-44 "Alternate Immersion Stress Corrosion Testing in 3.5% NaCL Solution" were adhered to for the program. Visual inspections as indicated in Table 6 were frequently performed. This effort was terminated after 1700 hours of continuous alternate immersion exposure at a time which was not pre-selected but convenient and more than adequate for Air Force needs.

*Tables begin on page 10.

SECTION III
OBSERVATIONS AND RESULTS

The corrosion testing commenced on 12 November 1981. In addition to the 18 total test blocks which had the fasteners installed to .002" to .004" interference levels, 3 additional test blocks ("bare" only) were prepared with higher interference levels. Fasteners were installed in these three blocks with 0.007" to 0.008" of interference which is not a recommended practice. This slight variation was included so that comparisons could be made with the specimens at standard interference levels. All test specimens were simultaneously immersed. Observations were limited only to the dry periods (50 minutes dry/10 minutes wet) of the immersion cycle. Visual inspection included low power magnification at times when "naked eye" observations were suspect.

The following observations for the "standard" interference specimens were recorded in a log and are summarized below.

1. After 144 hours a byproduct of corrosion, "red rust", was noticed on SLEEVbolt heads.
2. At 192 hours the "red rust" on SLEEVbolt heads had turned brown and appeared somewhat stabilized.
3. Some cadmium depletion (flaking) was noticed on Taper-Lok fastener heads at 312 hours.
4. The first visible crack in the block material appeared at 360 hours in a cold worked hole with a Hi-Lok fastener in the Short Transverse - Longitudinal (ST-L grain direction) plane.
5. At 504 hours there were 1 to 2 cracks present in a representative block from each fastener group (ST-L).

6. By 648 hours cracks were present not only from the edge of the blocks to the first fastener but also between fasteners in the ST-L direction of the bare blocks. Two out of three Taper-Lok and Cold Work plus Hi-Lok specimens and three out of three SLEEVbolt specimens had multiple cracks as described.
7. At 768 hours the third Taper-Lok specimen cracked.
8. All of the "bare" specimens exhibited multiple cracks restrained to (ST-L) grain orientation at 960 hours.
9. At 1008 hours of alternate immersion cycling NO shot peened blocks showed signs of cracking.
10. At 1656 hours cracks had also started in the Short Transverse - Long Transverse plane(ST-LT), in one Taper-Lok specimen.
11. At 1776 hours one SLEEVbolt specimen was also found to have cracks present in the (ST-LT) plane.
12. During inspection, after termination of the environmental exposure, the first crack in a Shot-Peened specimen was noticed in the (ST-L) plane.

Observations of the non-standard 0.007" to 0.008" interference blocks are as follow:

1. The first "high" interference block cracked after 264 hours, the second at 312 hours, and the third at 648 hours in the (ST-L) plane. At 768 hours all "high" interference blocks had multiple cracks. See Table 6.

Subsequent to the environmental exposure, the fasteners were removed

from the blocks. Corrosion products were removed by cleaning the blocks in a sodium hydroxide solution followed by a nitric acid "bright"dip. A

final visual inspection was then performed in which the number of affected holes (more than one crack per hole is possible) were counted as opposed to the number of individual cracks. More precise documentation of the final results is presented in sketches of the individual test blocks as shown. See Table 7 and Figures 4 through 15.

Eddy current inspection on selected blocks revealed few cracks that were not apparent during visual inspection. Most of these were located in holes which also had a larger crack previously documented. For these reasons it was felt that an extensive NDI inspection was not necessary.

SECTION IV

CONCLUSIONS

1. In bare specimens initial cracks started from outside the fastener hole at the edge of the block in the ST-L direction, indicating the presence of residual stress interaction with the "free" edge.
2. Shot peening the block material to an Almen intensity of 0.008 to 0.010 using MI 230 shot or equivalent with a 200% coverage greatly reduced stress corrosion cracking susceptibility.
3. Fastener interference of 0.007" to 0.008" in the "bare" blocks significantly accelerated stress corrosion cracking in 7075-T6.
4. Up to 1000 hours of accumulated test exposure no apparent significant difference between the three systems installed at standard interference was noticed.
5. After final inspection and cleaning it was obvious that of the three systems evaluated, the 3.5% Cold Work and 0.002" interference Hi-Lok system resulted in the least amount of cracking. In fact, the shot peened blocks with this system installed showed no signs of visible cracks through the test program.
6. The Taper-Lok and SLEEVbolt systems under the installed conditions were judged to be equal with regard to stress corrosion damage.
7. Virtually all cadmium plating on the heads of Taper-Lok and Hi-Lok fasteners was eroded. Fastener heads appeared to be a dull "steel" gray with isolated spots of red rust on several but not all fasteners.
8. Even though the Kal-Guard coating on the PBF SLEEVbolts was the first system to show signs of coating depletion this affected only 15% of the installed PBF fasteners. The remainder looked exceptionally good

at the end of the test.

9. Crevice corrosion (bearing area) was noticed on the block surfaces when the nuts were removed.

SECTION V
RECOMMENDATIONS FOR FUTURE WORK

1. Different candidate systems should be evaluated under the same installation parameters. Systems presently being considered are: J.O. King solid sleeve cold working system with Hi-Lok, Hi-Shear Hi-Tigue, and Kaynar K-Lobe.
2. For ease of fastener/nut installation, countersinks should be placed on the inside surfaces of the blocks. It became difficult to install nuts at certain fastener locations with the present block design.
3. Caution should be exercised when selecting material for evaluation. It was found that different heats of 7075-T6 extruded material varied with respect to stress corrosion cracking susceptibility. All material used in this effort was from a single extrusion.
4. Establish better correlations between service life and laboratory accelerated testing.

TABLE 1 - Taper Lok Head Protrusion

Block I D	Head Protrusion (inches)			
	1	2	3	4
<u>Bare</u>				
33 T	.135	.1375	.111	.141
L	.162	.157	.172	.1645
S	.158	.169	.160	.173
29 T	.141	.155	.145	.147
L	.154	.156	.157	.160
S	.149	.161	.189	.177
22 T	.178	.165	.159	.166
L	.1675	.156	.162	.150
S	.152	.151	.161	.144
<u>Shot Peened</u>				
32 T	.1535	.147	.161	.142
L	.155	.146	.150	.155
S	.141	.143	.141	.152
24 T	.154	.154	.162	.159
L	.140	.155	.149	.146
S	.151	.148	.140	.138
35 T	.150	.156	.158	.155
L	.152	.146	.145	.162
S	.154	.150	.140	.140

Note: Holes are numbered left to right, then top to bottom.

Interference = Protrusion \div 48

TABLE 2 - Hi-Lok Specimens after Cold Work and Post Ream

Block I D	Hole Diameters (inches)			
	1	2	3	4
<u>Bare</u>				
5 T	.2162	.2161	.2162	.2162
L	.2162	.2162	.2161	.2162
S	.2162	.2161	.2160	.2161
9 T	.2162	.2162	.2162	.2162
L	.2162	.2161	.2162	.2161
S	.2162	.2161	.2157	.2160
10 T	.2162	.2162	.2162	.2161
L	.2162	.2161	.2162	.2162
S	.2160	.2162	.2161	.2162
<u>Shot Peened</u>				
3 T	.2161	.2160	.2161	.2161
L	.2162	.2161	.2161	.2161
S	.2162	.2161	.2160	.2160
7 T	.2161	.2162	.2162	.2162
L	.2162	.2161	.2162	.2161
S	.2161	.2161	.2162	.2162
27 T	.2161	.2159	.2162	.2161
L	.2161	.2160	.2161	.2161
S	.2162	.2162	.2162	.2161

Note: Holes are numbered left to right, then top to bottom.

TABLE 3 - Hole Diameters Before Cold Work (split sleeve system)

Block I D	Hole Diameters (inches)			
	1	2	3	4
<u>Bare</u>				
5 T	.1940	.1945	.1945	.1950
L	.1955	.1950	.1945	.1955
S	.1955	.1950	.1945	.1955
9 T	.1945	.1945	.1945	.1950
L	.1950	.1950	.1945	.1960
S	.1945	.1945	.1955	.1955
10 T	.1950	.1950	.1945	.1950
L	.1950	.1950	.1945	.1965
S	.1945	.1950	.1945	.1950*
<u>Shot Peened</u>				
3 T	.1945*	.1945	.1940	.1950
L	.1945	.1950	.1945	.1960
S	.1950	.1940	.1940	.1950
7 T	.1955	.1950	.1945	.1950
L	.1950	.1950	.1955	.1955
S	.1950	.1950	.1960	.1955
27 T	.1950	.1945	.1940	.1945
L	.1950	.1945	.1940	.1960
S	.1950	.1940	.1935	.1960

Note: Holes are numbered left to right, then top to bottom.

* These specimens were inadvertently cold worked with a used sleeve.

TABLE 4 - SLEEVbolt Specimens

Block I D	Hole Diameters (inches)			
	1	2	3	4
<u>Bare</u>				
25 T	.2424	.2425	.2423	.2423
L	.2423-.2431	.2424	.2424	.2425
S	.2424	.2423	.2423	.2423
34 T	.2429	—	.2426	.2425
L	.2423	.2426-.2434	.2428	.2430-.2434
S	.2425	.2428	.2427	.2428
21 T	.2424	.2424	.2423	.2422
L	.2424	.2422	.2423	.2423
S	.2424	.2424	.2423	.2423
<u>Shot Peened</u>				
8 T	.2425	.2424	.2424	.2424
L	.2424	.2424	.2425	.2425
S	.2424	.2424	.2424	.2424
19 T	.2424	.2425	.2425	.2425
L	.2426	.2425	.2425	.2425
S	.2425	.2423	.2424	.2423
36 T	.2424	.2423	.2424	.2423
L	.2425	.2424	.2425	.2424
S	.2423	.2424	.2421-.2425	.2425

Note: Holes are numbered left to right, then top to bottom.

TABLE 5 -- Level of Interference

Fastener I.D.	Interference (inches)	
Taper Lok 3TL 13-3	protrusion	.111-.189
	mean	.153
	interference	.002-.004
	mean	<u>.003</u>
Cold Work Fatigue Technology	starting hole	.1965-.1935
	mean	.1950
	expansion	.0055-.0085
	mean	.007
	expansion %	3%-4%
	mean	<u>3.5%</u>
Hi-Lok HL 221-6	hole diameter	.216
	pin diameter	.218
	interference	<u>.002</u>
PBF Sleevebolt SB 110-3	hole diameter	.2425
	max part diam ¹	.2455-.2465
	interference	<u>.003-.004</u>

1. Pin and sleeve expanded.
2. Fastener systems were assembled with Kaynar KFN 600-3 nuts torqued to 30 inch-lbs.

TABLE 6 - ASTM G-44 Alternate Immersion Test 3.5% NaCl Results

"Bare" Blocks Only

Date/Time	Block ID	Fastener Type	Cracks/Location
12 Nov: Start	All	All	None
16 : 96 hours	"	"	None
18 : 144	"	"	None
20 : 192	"	"	None
23 : 264	"	"	None ²
25 : 312	"	"	None ³
27 : 360	10	CW&HL	1, ST-L ⁴
1 Dec: 456	Same	Same	Same
3 : 504	10	CW&HL	2, ST-L
	33	TL	1
	34	PBF	2
4 : 528	Same	Same	Same
7 : 600	10, 5	CW&HL	2, 2, ST-L
	33	TL	1
	34, 21, 25	PBF	2, 2, 2
9 : 648	10, 5	CW&HL	2, 2, 5, ST-L
	33, 29	TL	1, 2
	34, 21, 25	PBF	2, 2, 2
11 : 696	Same	Same	Same
14 : 768	10, 5	CW&HL	2, 2, 6, ST-L
	33, 29, 22	TL	1, 2, 1
	34, 21, 25	PBF	2, 2, 2
16 : 816	Same	Same	Same
18 : 864	Same	Same	Same

TABLE 6 Continued

Date/Time	Block ID	Fastener type	Cracks/Location
22 : 960	10, 5, 9	CW&HL	2, 2, 2 ST-L
	33, 29, 22	TL	2, 2, 2
	34, 21, 25	PBF	2, 2, 2 ⁸
24 : 1008	Same	Same	Same
28 : 1104	Same	Same	Same
31 : 1176	10, 5, 9	CW&HL	2, 2, 2 ST-L
	33, 29, 22	TL	3, 2, 3
	34, 21, 25	PBF	2, 2, 2
4 Jan : 1272	10, 5, 9	CW& HL	2, 3, 2 ST-L
	33, 29, 22	TL	3, 3, 3
	34, 21, 25	PBF	3, 3, 2
7 : 1344	Same	Same	Same
20 : 1656 ¹⁰	10, 5, 9	CW&HL	2, 3, 3 ST-L
	33, 29, 22	TL	4, 3, 3/1 ⁹ ST-L/ST-LT
	34, 21, 25	PBF	3, 3, 2 ST-L
25 : 1776	10, 5, 9	CW&HL	4, 3, 3 ST-L
	33, 29, 22	TL	4, 3, 3/1 ST-L/ST-LT
	34, 21, 25	PBF	3/1, 3, 3 ST-L/ST-LT

Code for Fastener Types

CW&HL Cold Work and Hi-Lok
 TL Taper Lok
 PBF PBF SLEEVbolt

NOTES:

1. Corrosion noted around PBF SLEEVbolt heads.
2. Crack in High Interference Block #1.
3. Cracks in High Interference Blocks #1 and #13, also cadmium depletion or flaking on Taper-Lok heads.
4. (ST-L) Short Transverse Stress Corrosion cracking with Crack propagation in the longitudinal direction.
5. Cracks in High Interference Blocks #1, #13, #17.
6. Severe cracks in High Interference Specimens. Blocks #1 and #17 exhibited cracks in both the (ST-L) and (ST-LT) grain orientation.
7. All aluminum nuts show signs of extensive corrosion.
8. At 1000 hours No shot peened blocks had cracks.
9. (ST-LT) Short Transverse stress corrosion cracking with crack propagation in the long transverse direction.
10. At this time the protective coatings on all fastener heads were seriously depleted.

TABLE 7. ASTM G-44 Alternate Immersion Test 3.5% NaCl Conclusions

22 November 1982

CONDITION	BLOCK ID	FASTENER TYPE	HOLES/LOCATION
Bare	5	CW&HL	4(ST-L), 1(ST-LT)
	9		2(ST-L), 1(ST-LT)
	10		4(ST-L)
Shot Peened	3		0, 0
	7		0, 0
	27		0, 0
Bare	33	TL	4(ST-L), 3(ST-LT)
	29		4(ST-L), 3(ST-LT)
	22		4(ST-L), 3(ST-LT)
Shot Peened	32		3(ST-L), 2(ST-LT)
	24		2(ST-L), 1(ST-LT)
	35		4(ST-L), 0
Bare	25	PBF	4(ST-L), 3(ST-LT)
	34		4(ST-L), 4(ST-LT)
	21		4(ST-L), 4(ST-LT)
Shot Peened	8		4(ST-L), 4(ST-LT)
	19		4(ST-L), 2(ST-LT)
	36		4(ST-L), 4(ST-LT)

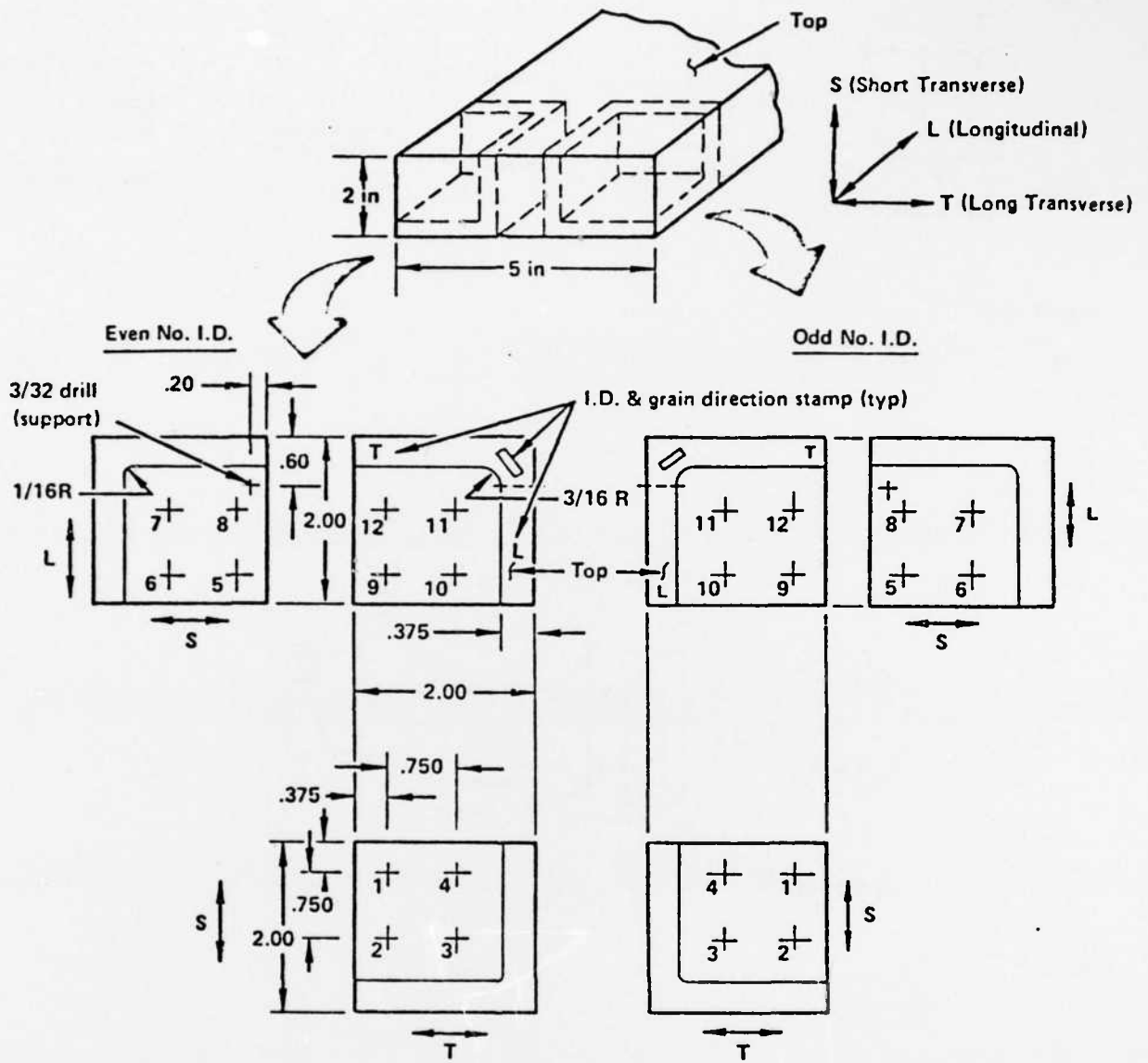

- NOTE:** 1. All dimensions typical
 2. 125 RHR finish
 3. Nominal hole diameter

Figure 1. Stress corrosion blocks and hole locations.
 7075-T6510, Reference 1

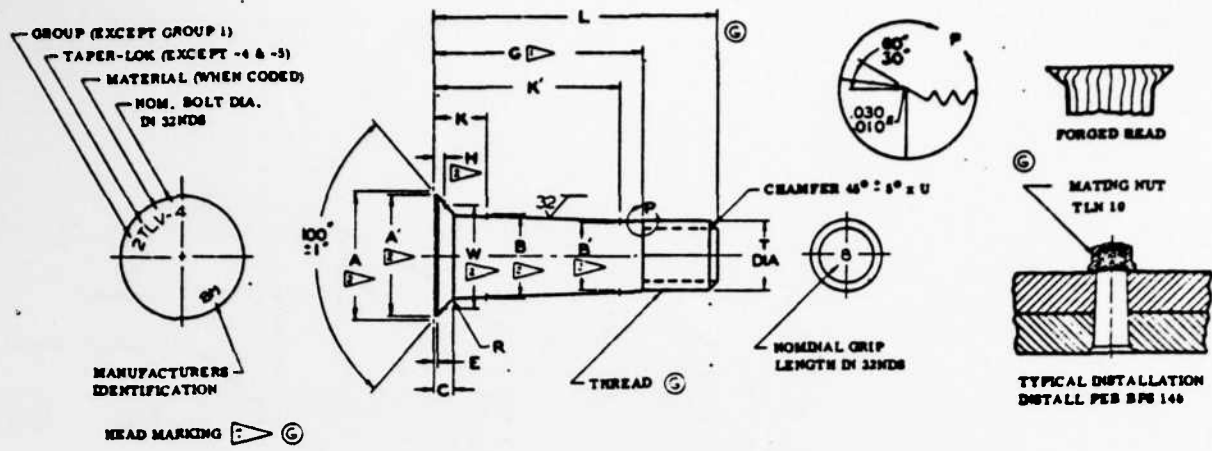

Tapor-Lok

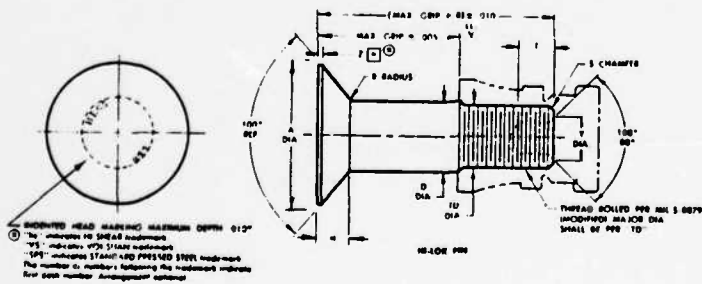
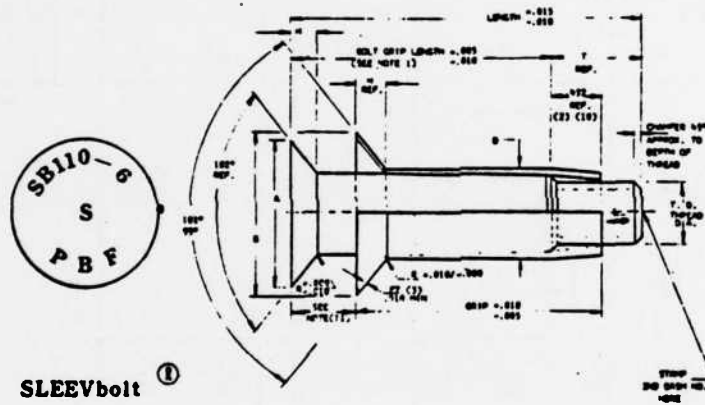
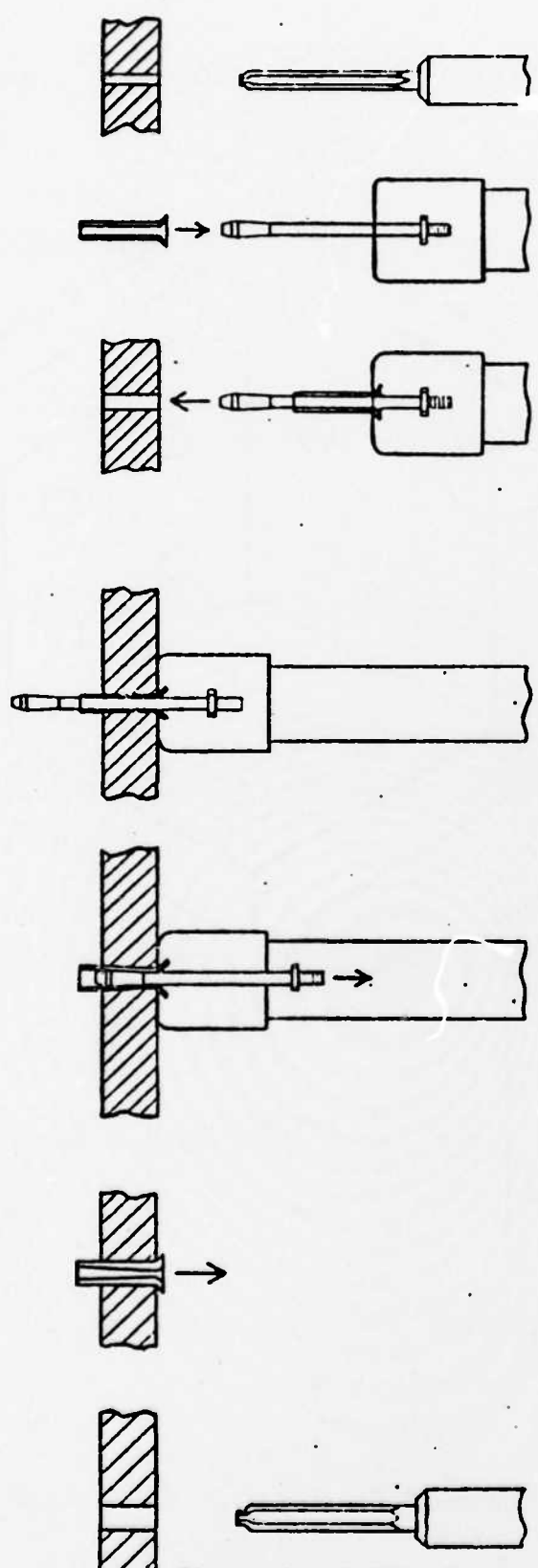
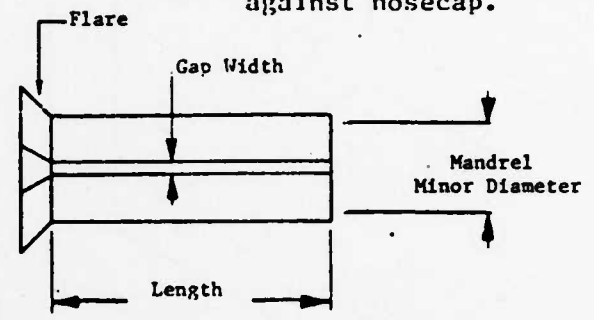

Figure 2. Fastener Systems



1. Drill and ream starting hole.

2. Slide sleeve over mandrel against nose cap.



3. Insert mandrel into hole.

4. Expand hole by pulling mandrel through hole with puller.

5. Remove distorted sleeve.

6. Ream hole to specified hole diameter using piloted finish reamer. Install fastener.

Figure 3. Split Sleeve Cold Expansion

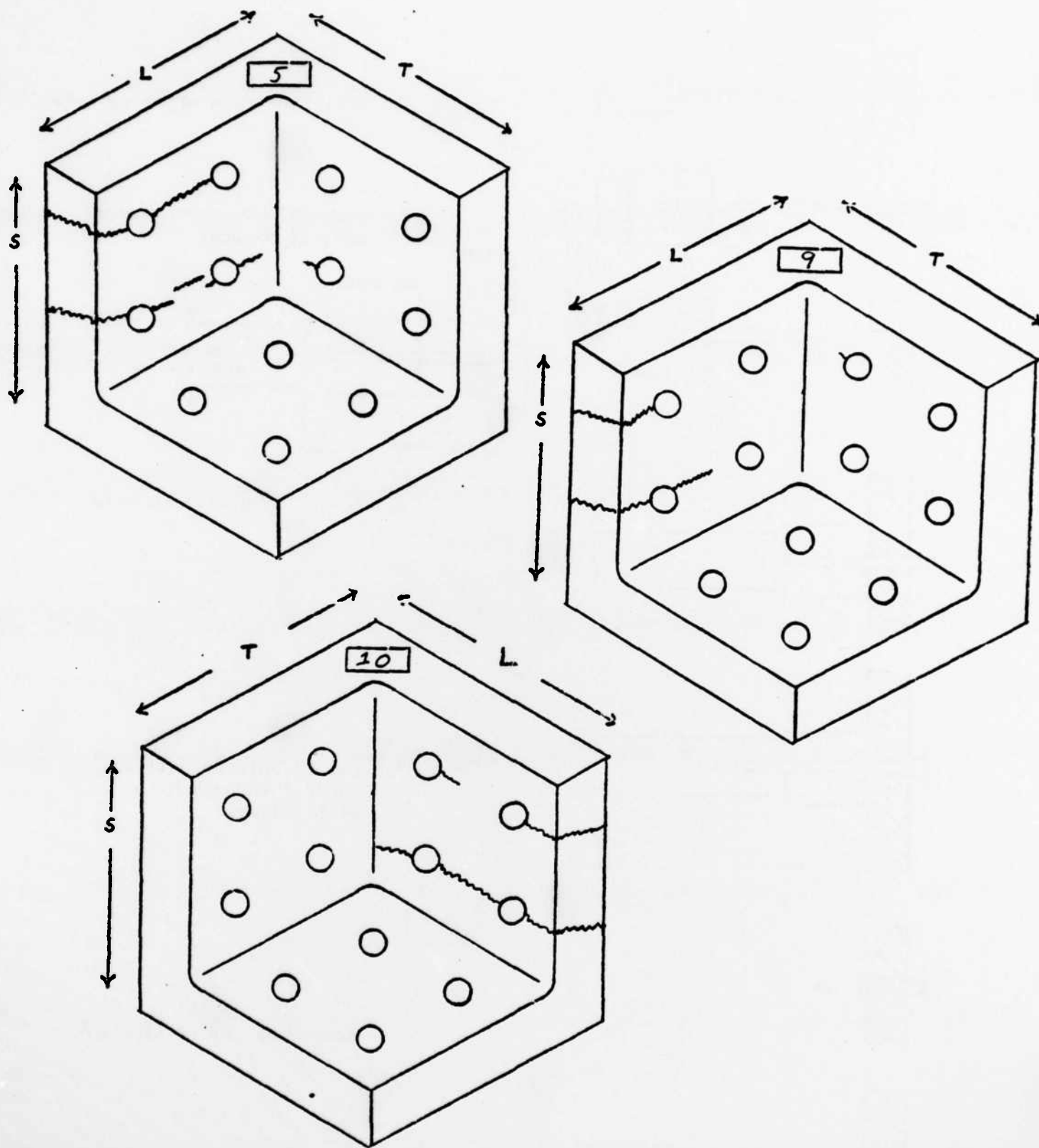

Figure 4. Cold Work/Hi-Lok Specimens (Bare) Final Results

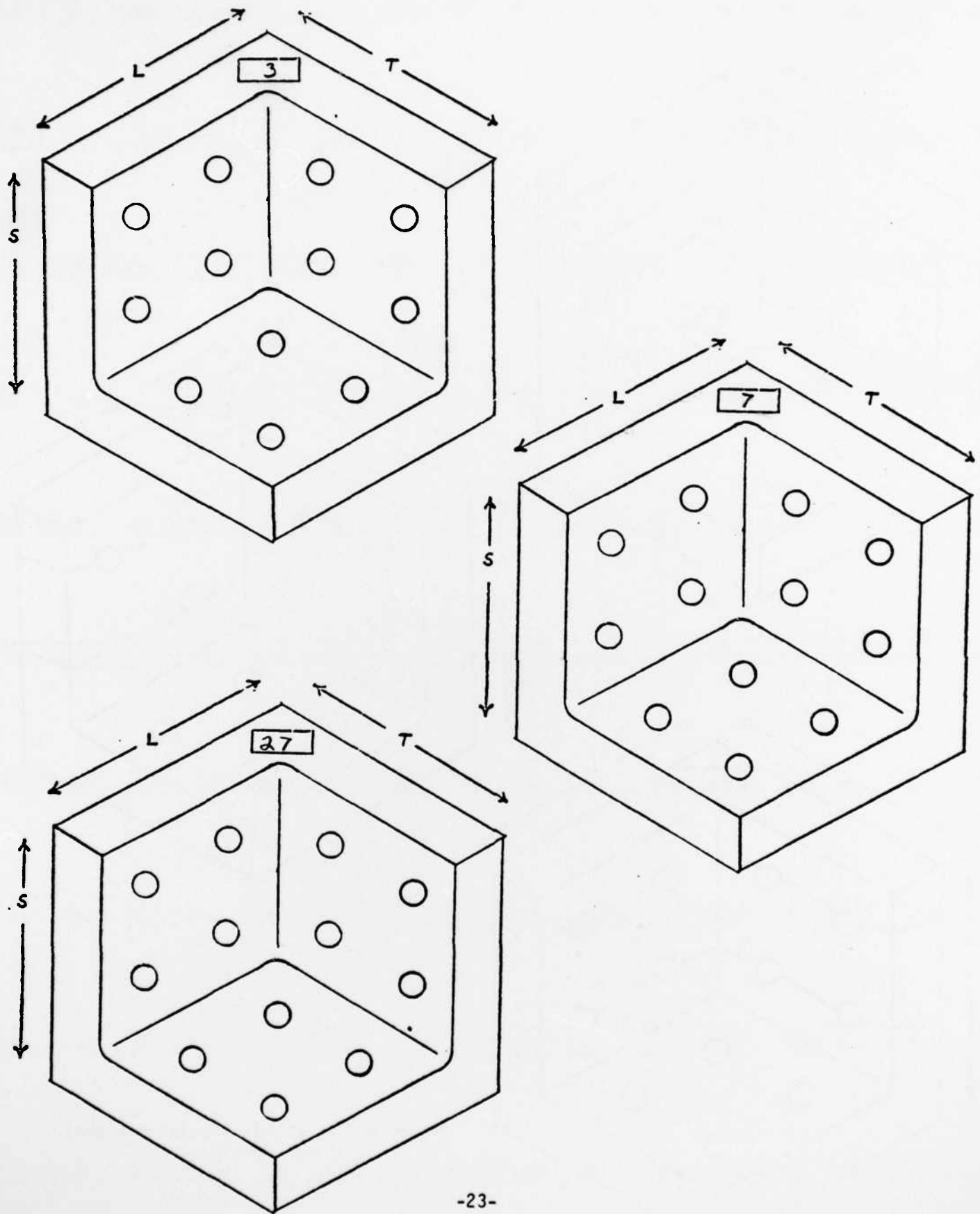

Figure 5. Cold Work/Hi-Lok Specimens (Shot peened) Final Results

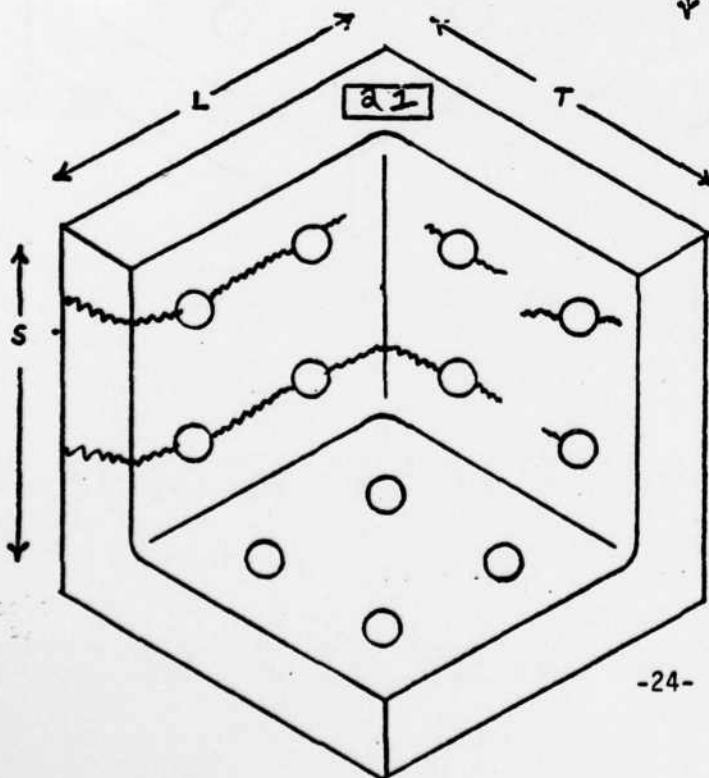
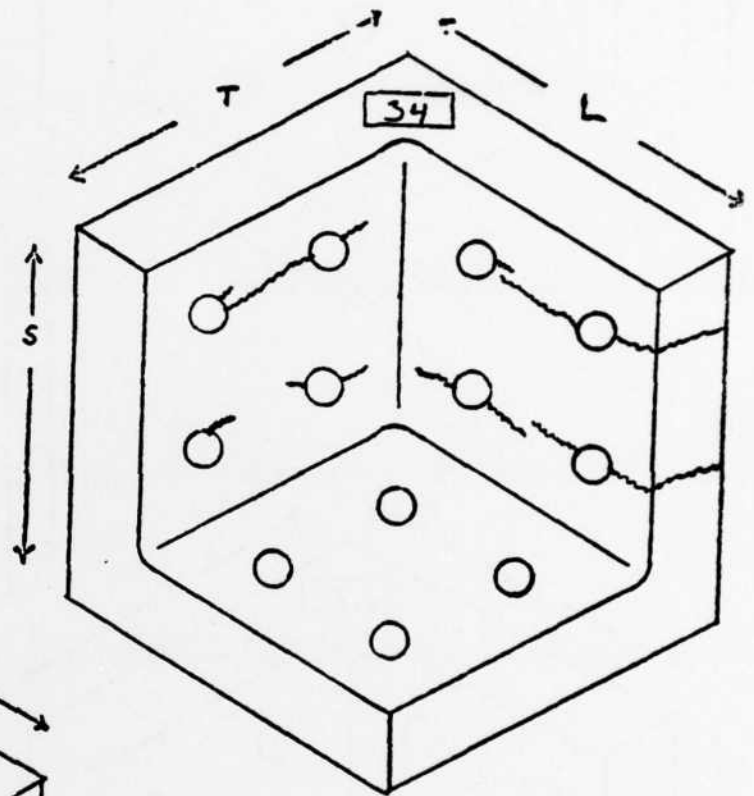
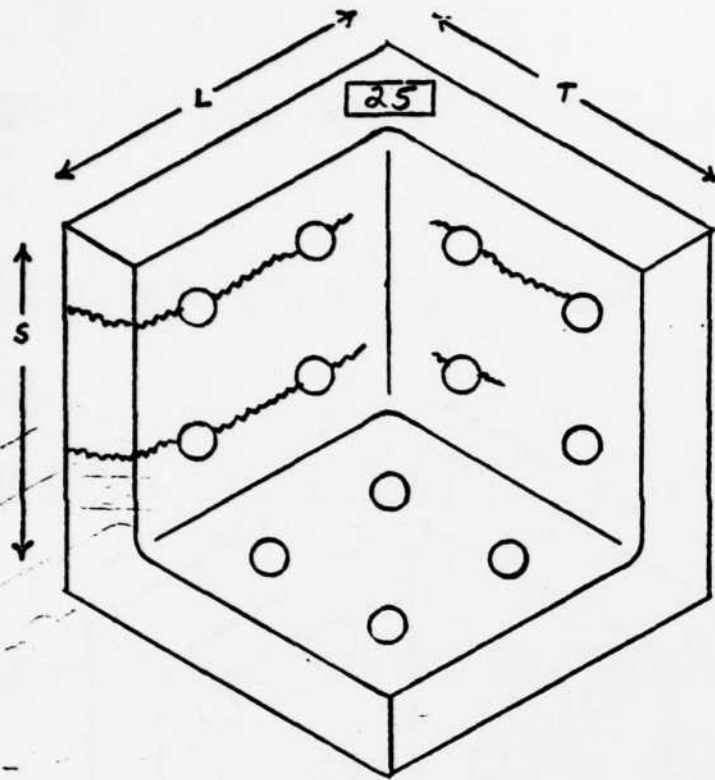

Figure 6. SLEEVbolt Specimens (Bare)
Final Results

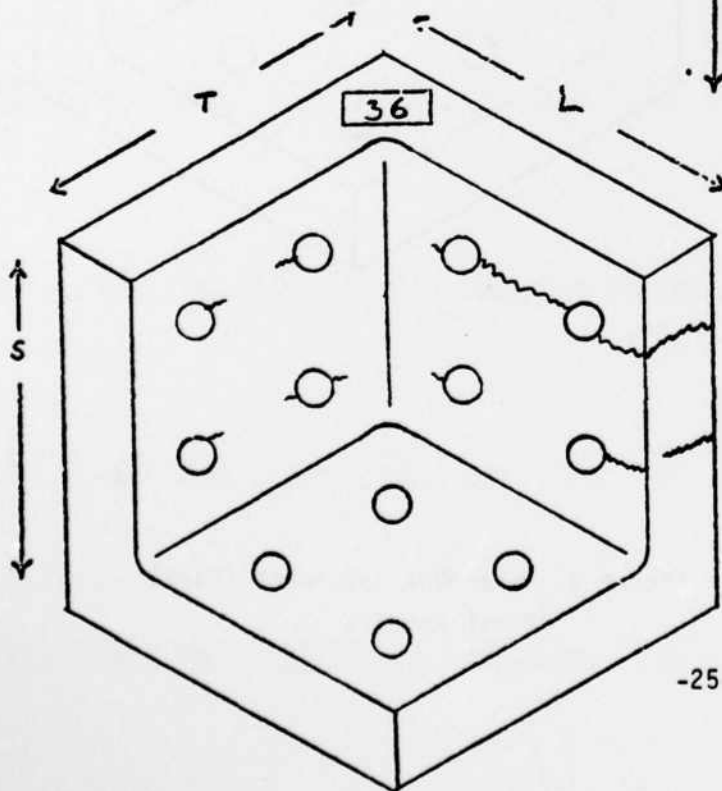
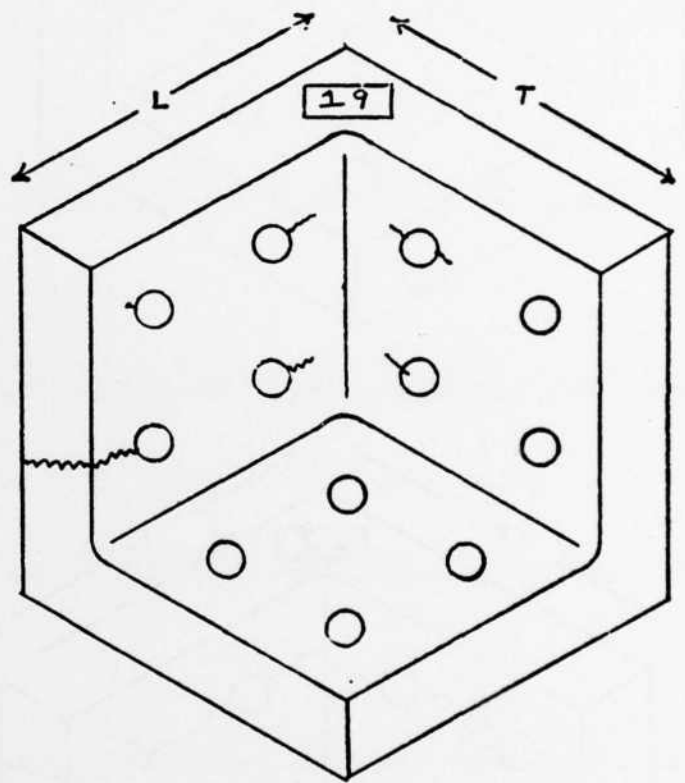
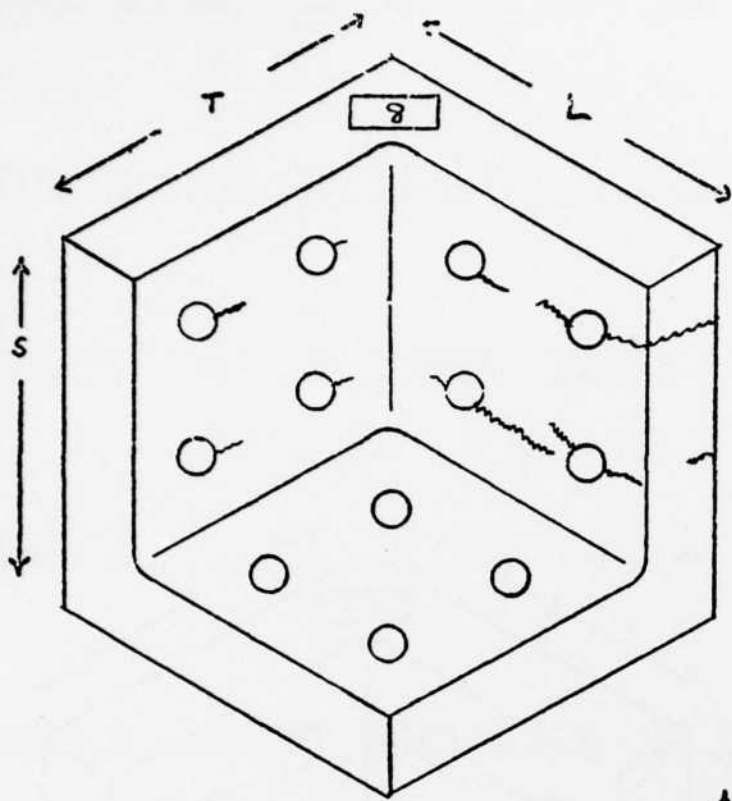

Figure 7. SLEEVBOLT Specimens (Shot Peened)
Final Results

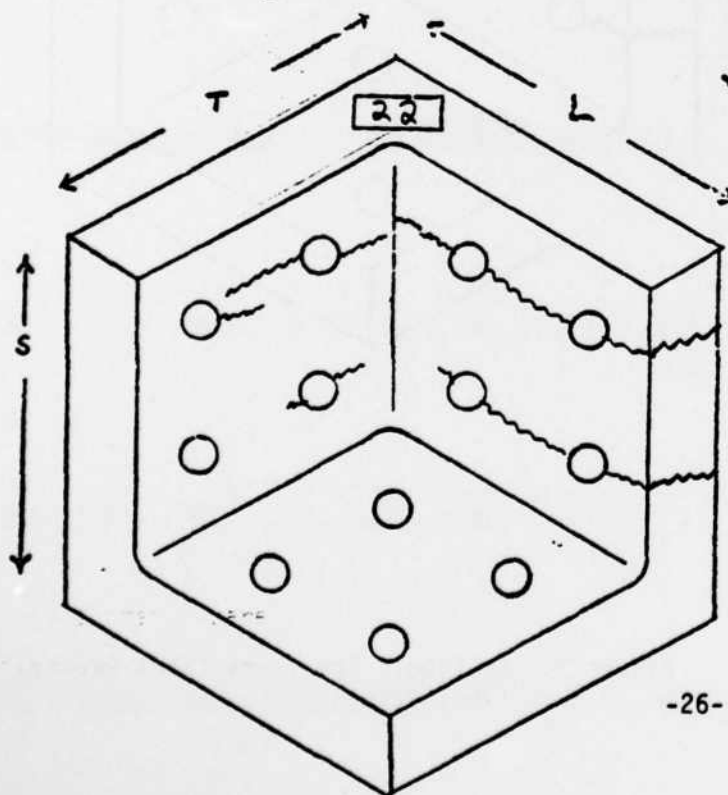
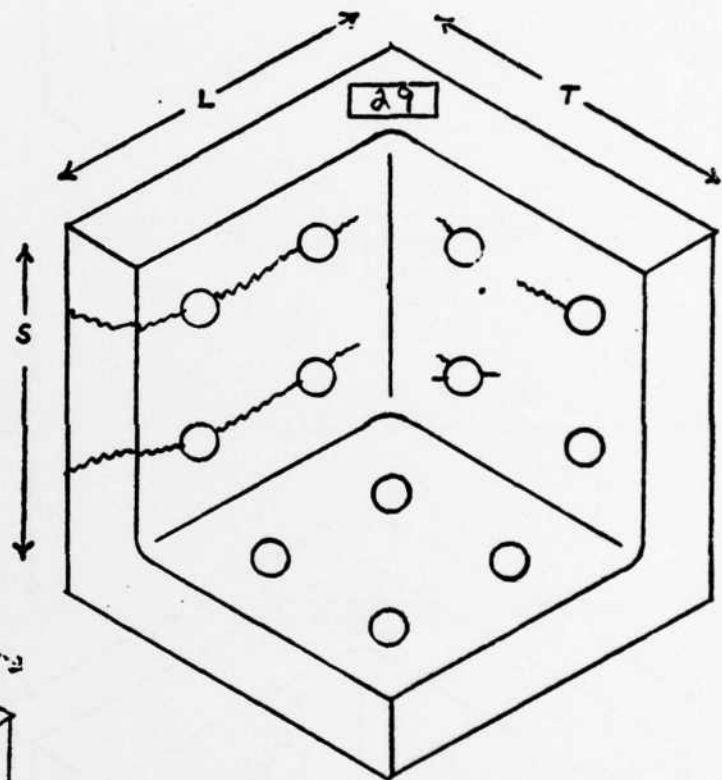
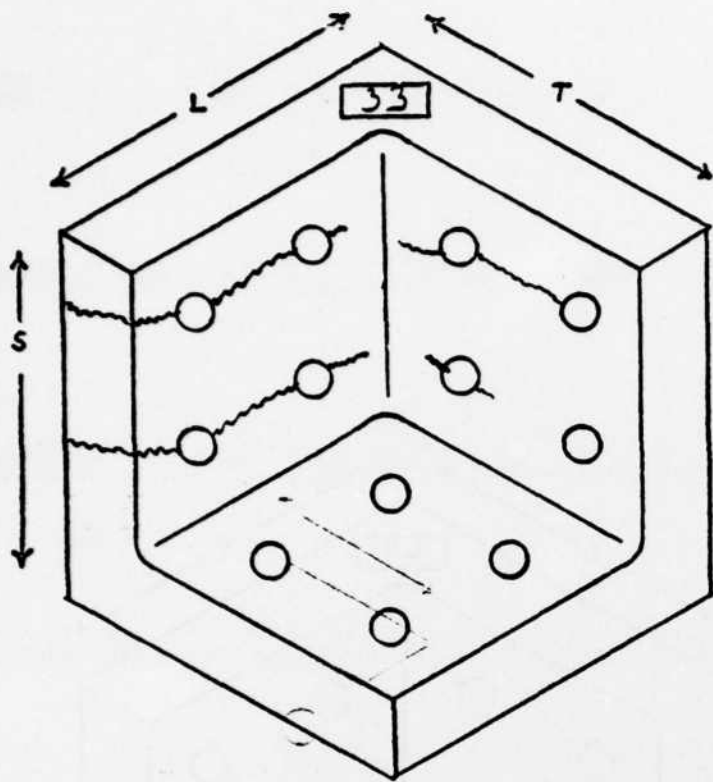

Figure 8. Taper-Lok Specimens (Bare)
Final Results

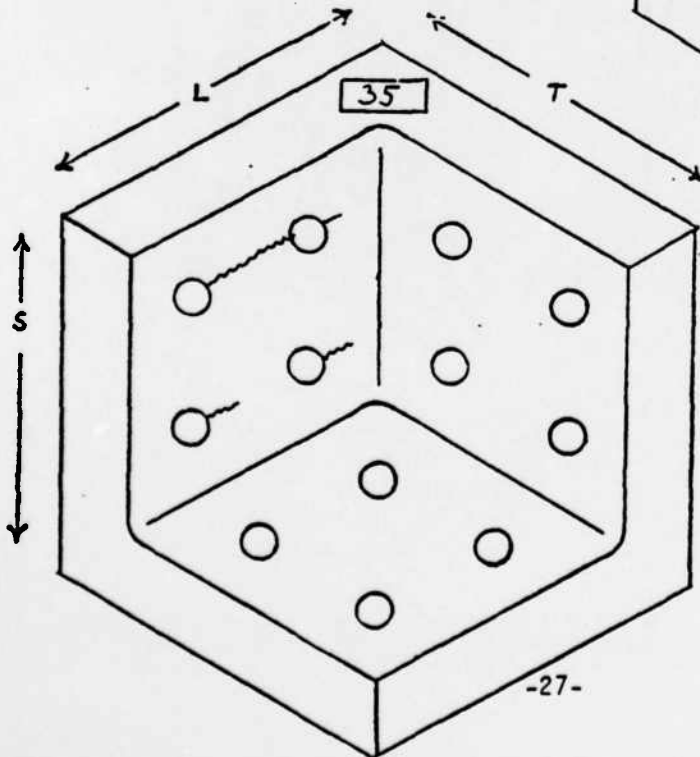
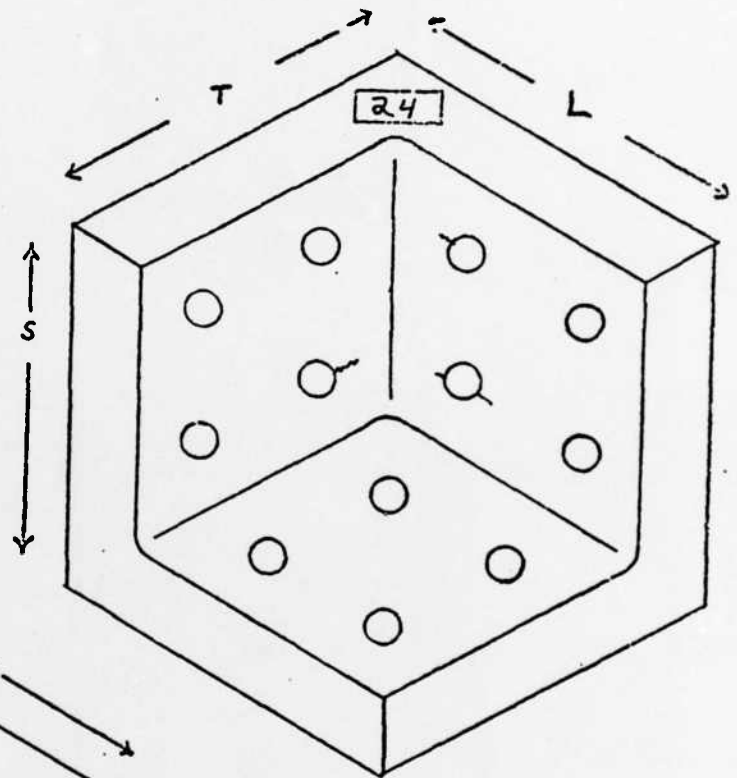
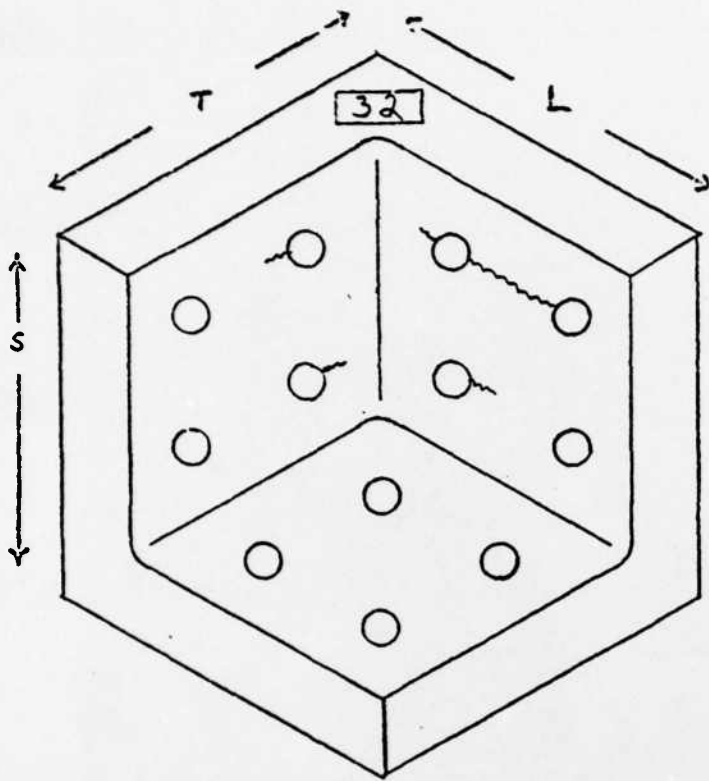

Figure 9. Taper-Lok Specimens
(Shot Peened)
Final Results

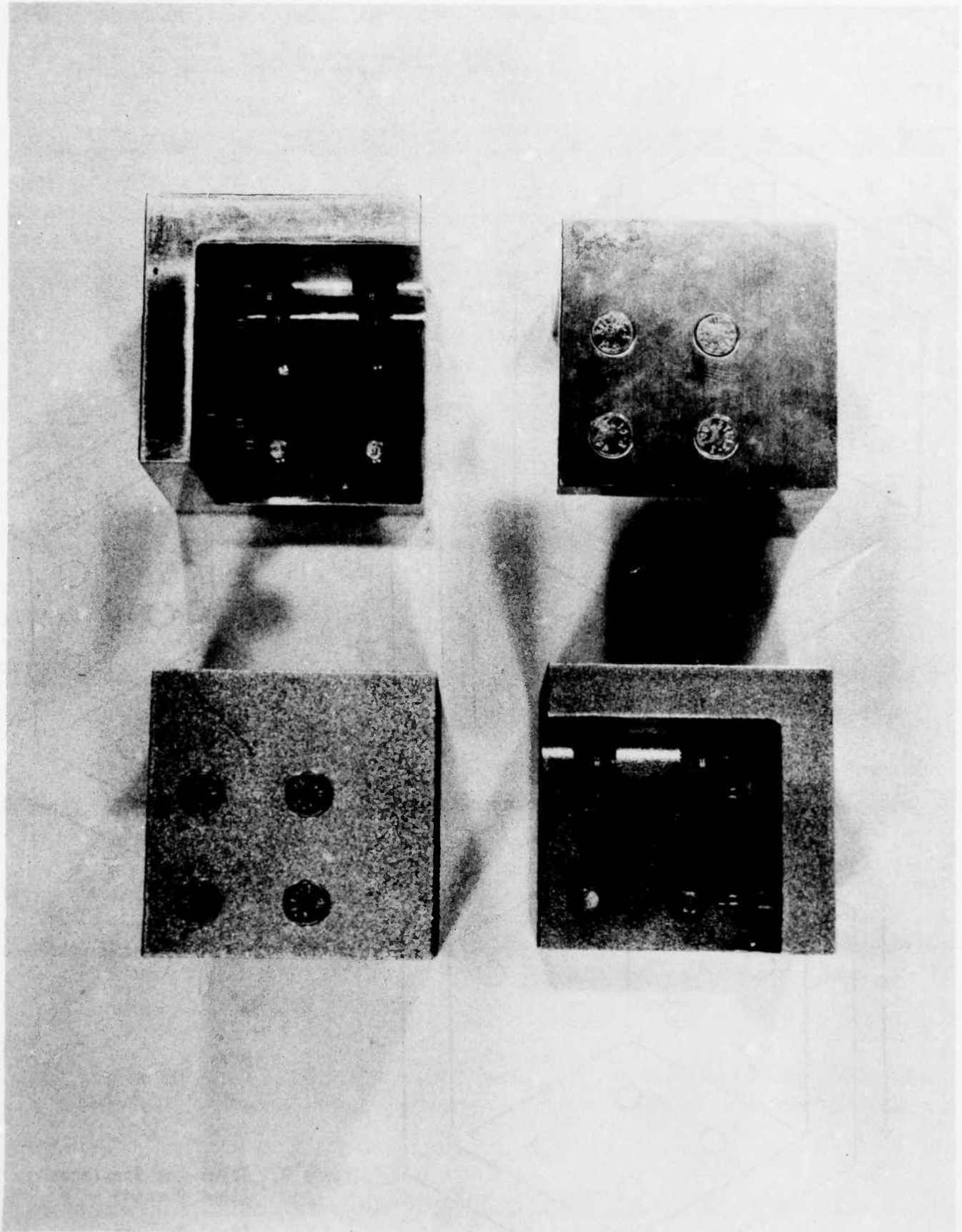

Figure 10. Taper-Lok Specimens Before Test "bare" Top, "Shot Peened" Bottom.

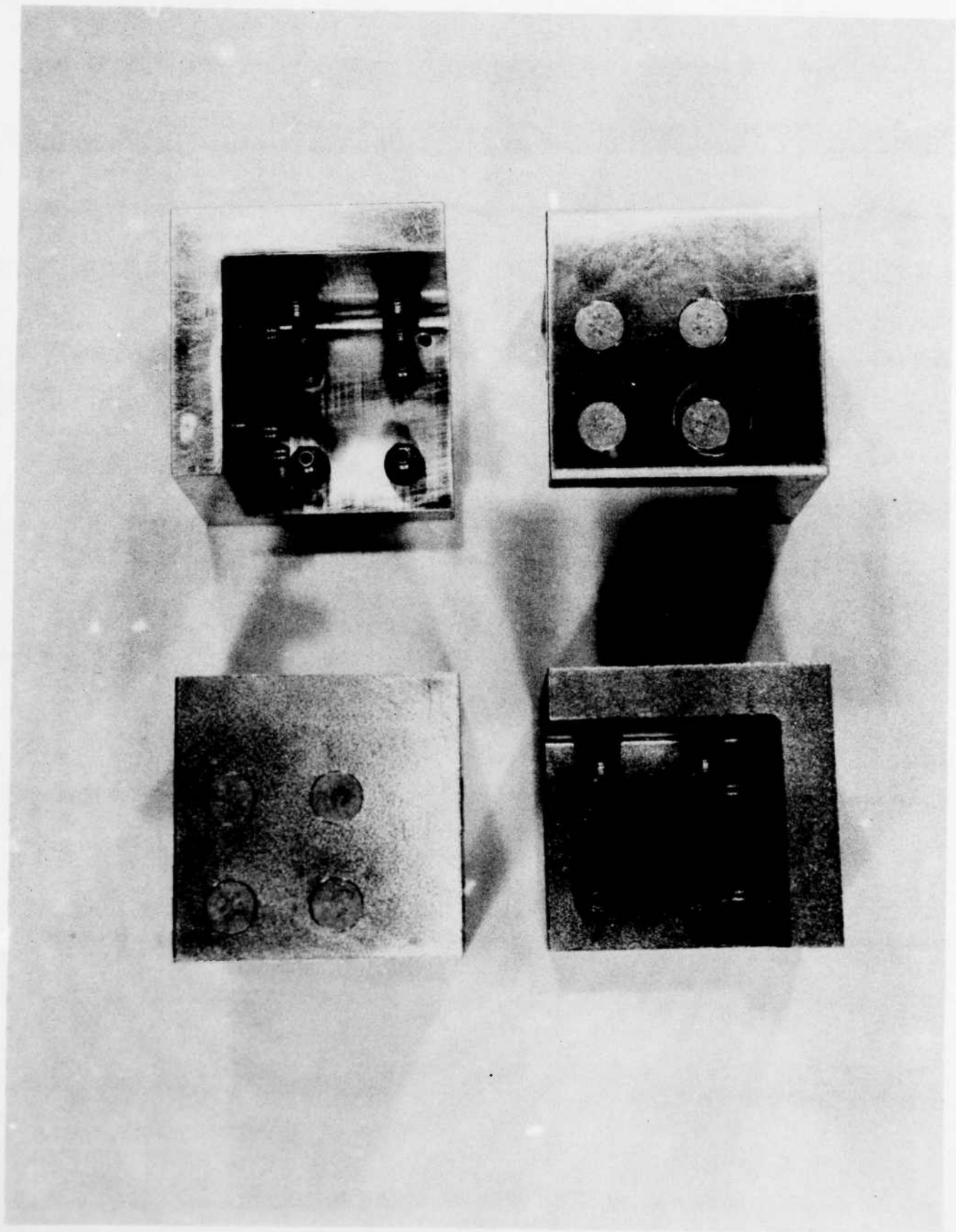

Figure 11. Cold Work/Hi-Lok Specimens Before Test "bare" Top, "Shot Peened" Bottom
-29-

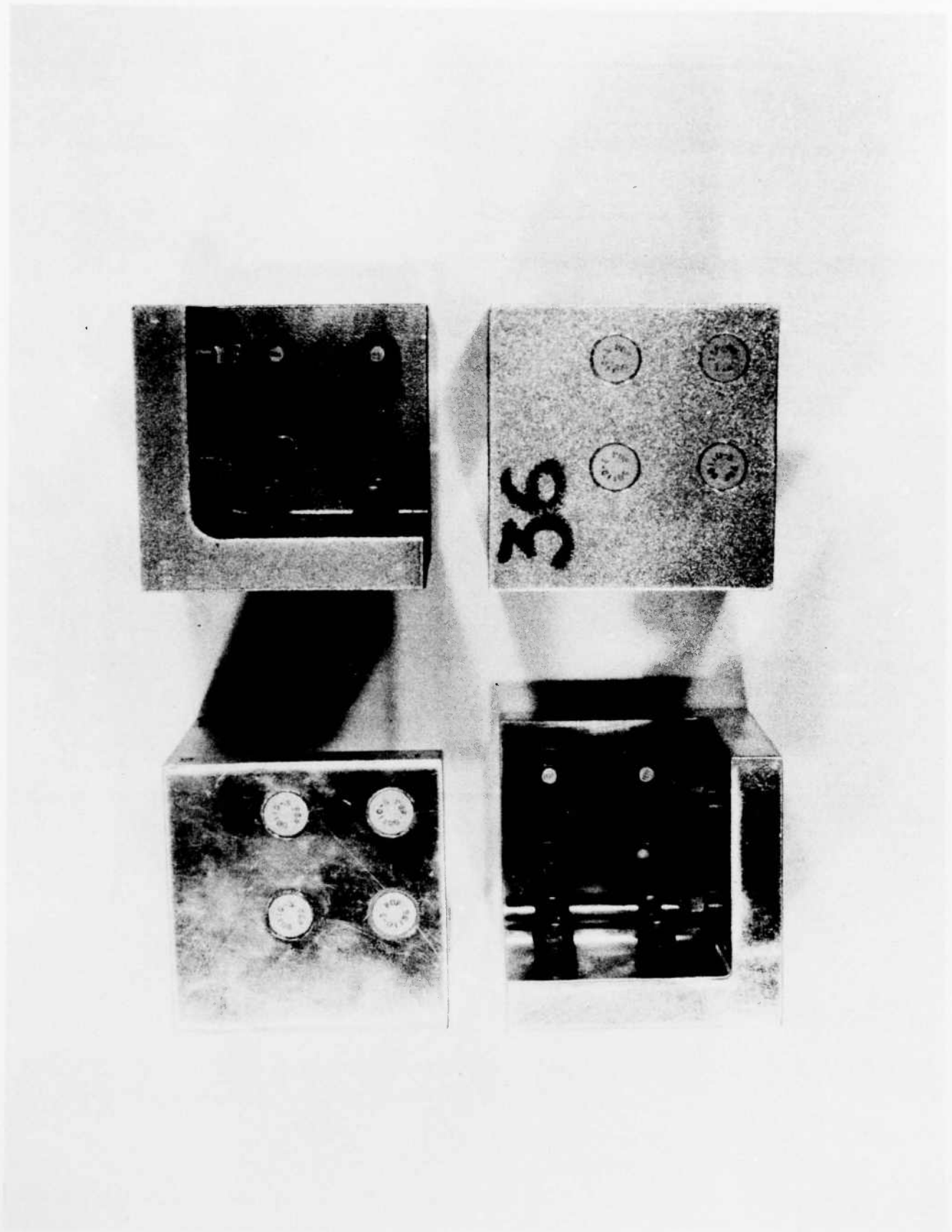

Figure 12. PBF SLEEVbolt Specimens before test "bare" Top, "Shot Peened" Bottom
-30-

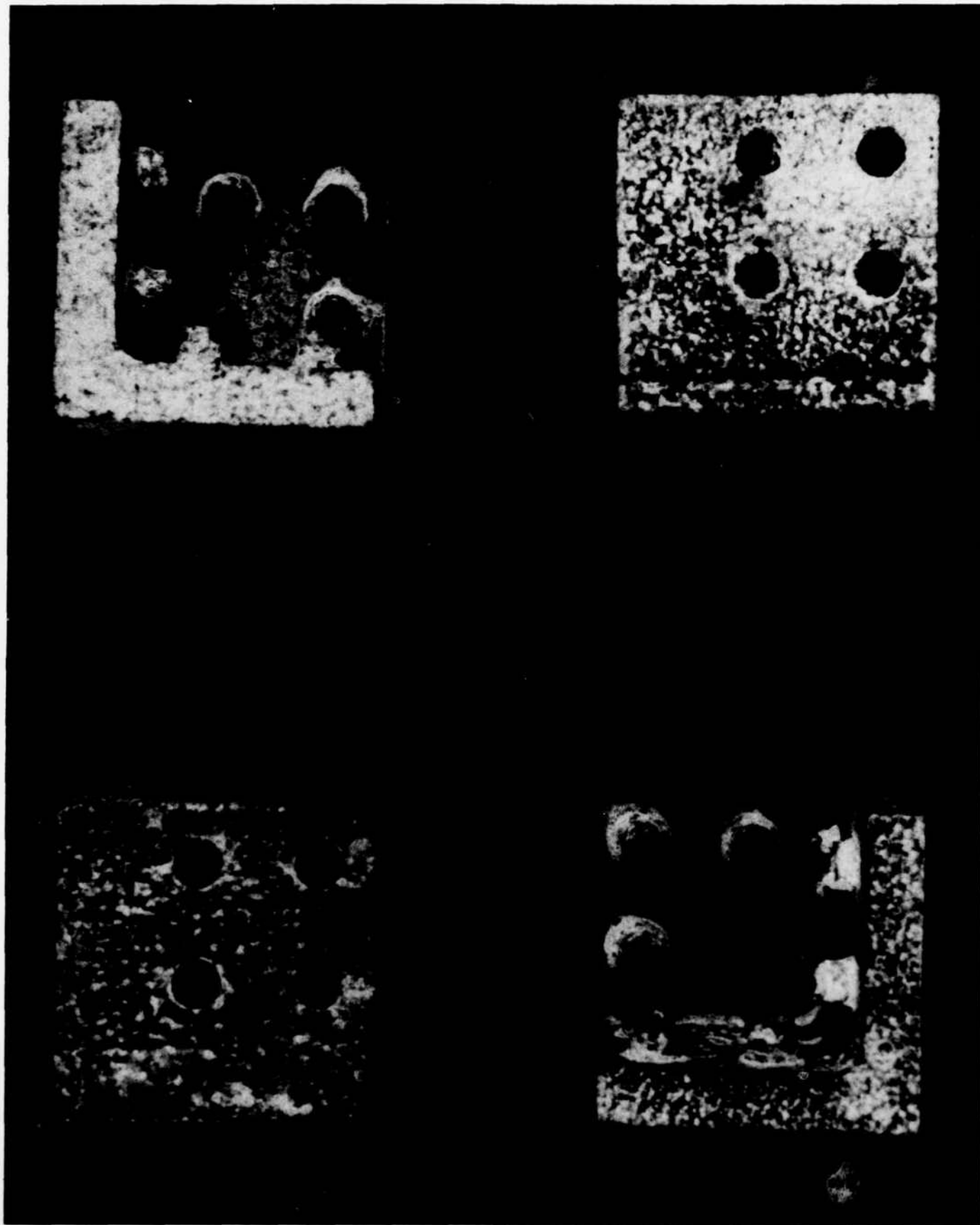

Figure 13. Taper-Lok Specimens After Test

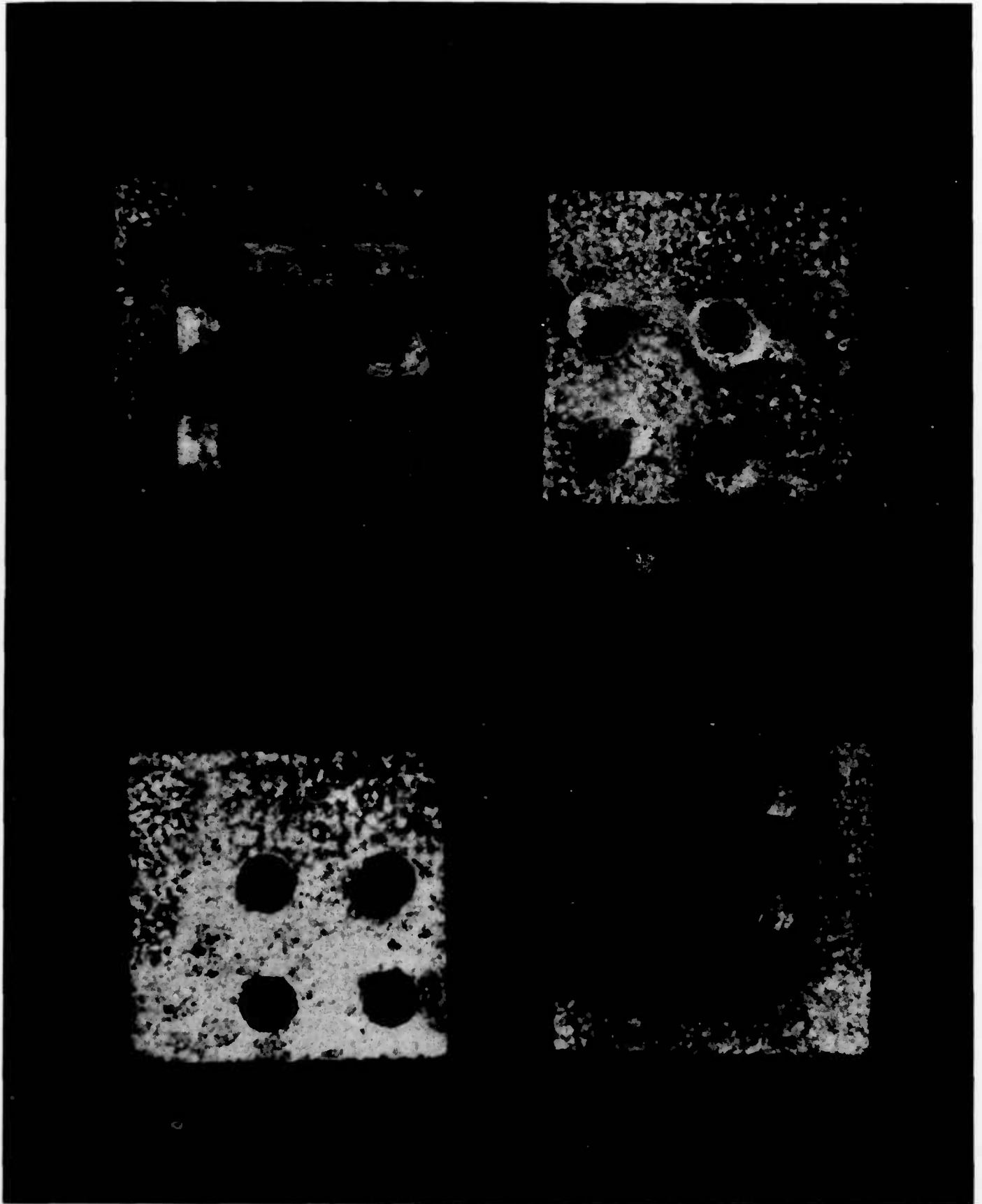

Figure 14. Cold Work/Hi-Lok Specimens After Test
-32-

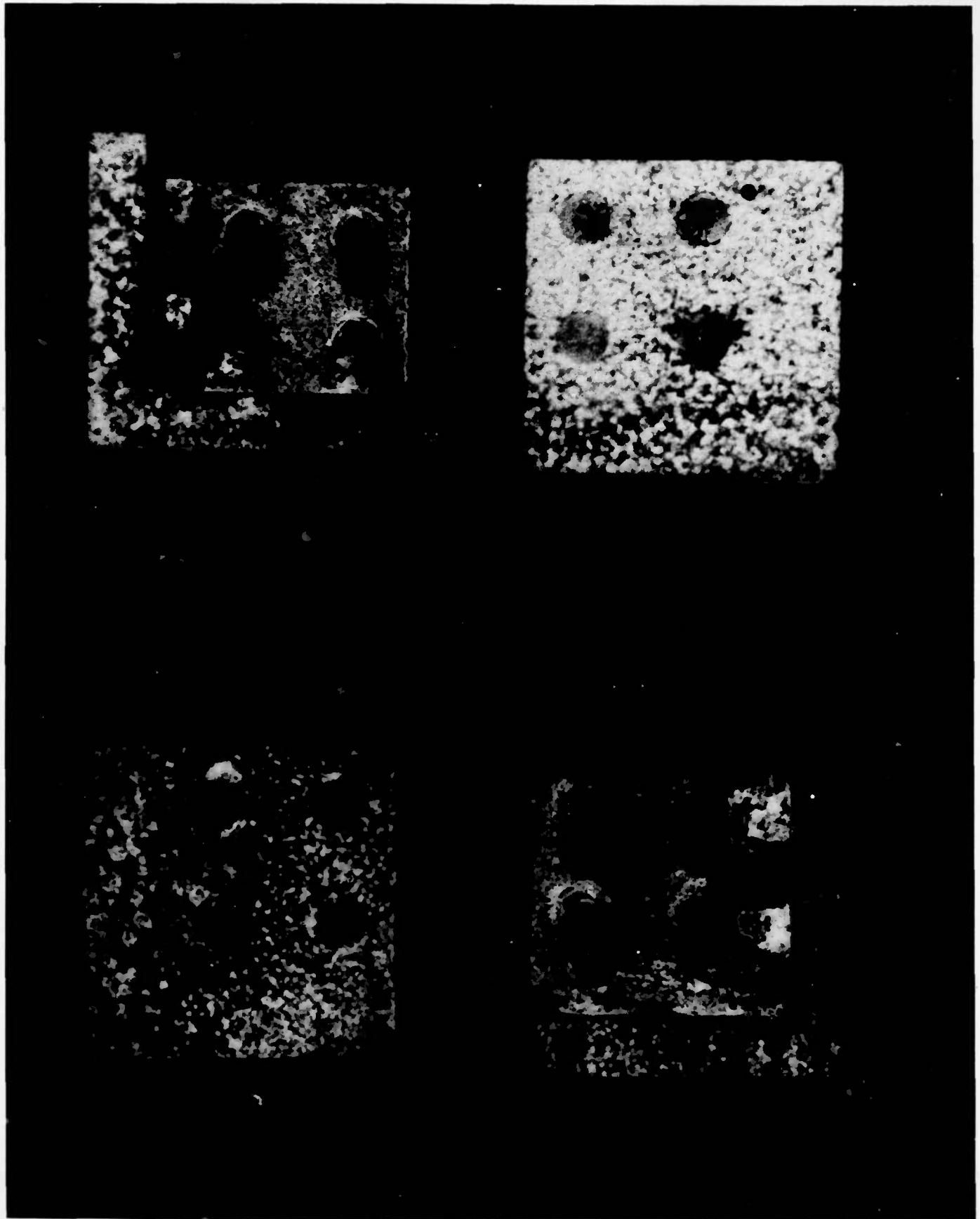

Figure 15. PBF SLEEVbolt Specimens After Test

END

FILMED

9-83

DTIC