

HD-A132 183

AN AIRBORNE COLOR VIDEO INSETTER (U) ARMY AVIATION
RESEARCH AND DEVELOPMENT COMMAND ST LOUIS MO
E A KARCHER ET AL. AUG 83 USAVRADCOM-TR-83-E-1

1/1

UNCLASSIFIED

F/G 17/2

NL

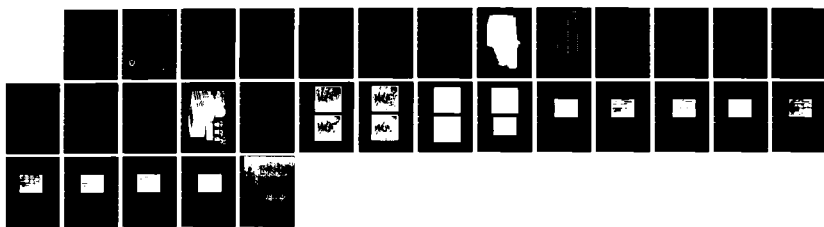

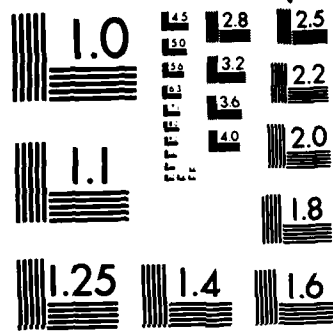

MICROCOPY RESOLUTION TEST CHART
NATIONAL BUREAU OF STANDARDS-1963-A

2

AVRADCOM

Technical Report -83-E-1

AN AIRBORNE COLOR VIDEO INSETTER

EDWARD A. KARCHER
US ARMY AVIONICS R&D ACTIVITY

VINCENT J. ORGANIC
US ARMY ELECTRONICS R&D COMMAND

AUGUST 1983

DISTRIBUTION STATEMENT
Approved for public release;
distribution unlimited.

ADA 132183

DTIC FILE COPY



Research and Development Technical Report
Aviation Research and Development Command

DTIC
SELECTED
SEP 7 1983
S D

83 09 06 063

NOTICES

Disclaimers

The citation of trade names and names of manufacturers in this report is not to be construed as official Government indorsement or approval of commercial products or services referenced herein.

Disposition

Destroy this report when it is no longer needed. Do not return it to the originator.

UNCLASSIFIED

SECURITY CLASSIFICATION OF THIS PAGE (When Data Entered)

REPORT DOCUMENTATION PAGE		READ INSTRUCTIONS BEFORE COMPLETING FORM
1. REPORT NUMBER AVRADCOM TR-83-E-1	2. GOVT ACCESSION NO. AD-A132183	3. RECIPIENT'S CATALOG NUMBER
4. TITLE (and Subtitle) An Airborne Color Video Insetter	5. TYPE OF REPORT & PERIOD COVERED	
	6. PERFORMING ORG. REPORT NUMBER	
7. AUTHOR(s) Edward A. Karcher (AVRADCOM) Vincent J. Organic (ERADCOM)	8. CONTRACT OR GRANT NUMBER(s)	
9. PERFORMING ORGANIZATION NAME AND ADDRESS System Architecture and Engineering Division Systems Evaluation Branch (DAVAA-F) Avionics R&D Activity, Fort Monmouth, NJ 07703	10. PROGRAM ELEMENT, PROJECT, TASK AREA & WORK UNIT NUMBERS 612202.U85.X1.12	
11. CONTROLLING OFFICE NAME AND ADDRESS Headquarters US Army Avionics R&D Activity ATTN: DAVAA-F Fort Monmouth, NJ 07703	12. REPORT DATE AUGUST 1983	
	13. NUMBER OF PAGES 25	
14. MONITORING AGENCY NAME & ADDRESS (if different from Controlling Office)	15. SECURITY CLASS. (of this report) UNCLASSIFIED	
	15a. DECLASSIFICATION DOWNGRADING SCHEDULE	
16. DISTRIBUTION STATEMENT (of this Report) Approved for public release; distribution unlimited.		
17. DISTRIBUTION STATEMENT (of the abstract entered in Block 20, if different from Report)		
18. SUPPLEMENTARY NOTES		
19. KEY WORDS (Continue on reverse side if necessary and identify by block number) Video Display Television Display Color Insetting		
20. ABSTRACT (Continue on reverse side if necessary and identify by block number) This report describes the design, interface, and operation of a general purpose raster scan display Color Video Insetter (CVI) which is capable of airborne operation. The CVI which operates on standard red, green, and blue (RGB) color signals, will select one of two background video inputs for display on up to three color monitors and inset into the background externally generated dynamic color features, fixed color features, or both.		

TABLE OF CONTENTS

	<u>Page</u>
1. INTRODUCTION	1
2. INTEGRATED MISSION PLANNING STATION (IMPS)	1
3. REQUIREMENTS	4
4. CIRCUIT DESCRIPTION	5
5. OPERATION	8
6. INTERFACE REQUIREMENTS	9
7. FABRICATION	10
8. TEST RESULTS	12
9. CONCLUSIONS	12

FIGURES

1. Color Video Insetter	2
2. Block diagram of Integrated Mission Planning Station	3
3. Block diagram of CVI circuitry	6
4. Block diagram of Synchronization Generation and Distribution circuitry	7
5. Color Video Insetter with printed circuit boards	11
6. Computer-generated map display	13
7. Map with terrain contours on A inset	13
8. Map with avionics symbology on B inset	14
9. Map with terrain contours and avionics symbology	14
10. Inset display with contours on A inset	15
11. Inset display with avionics symbology on B inset	15
12. Inset display with contours and avionics symbology	16
13. Display output with background video	16
14. Display output with background video	17
15. Display output with background video and A inset	18
16. Display output with background video and B inset	19
17. Display output with background video and A and B inset	20
18. Display output with background video and low-level A and B inset	21
19. Display output with background video and B over A inset	22
20. Display output with B inset over background video	23
21. Display output with A inset over background video	24
22. Display output with A and B inset over background video	25

ACKNOWLEDGEMENT

The authors wish to acknowledge the contributions of Mr. James Vandover and Mr. Benjamin Turner of the Electronics Technology and Devices Laboratory and Technical Support Activity, respectively, of ERADCOM for their assistance in the fabrication of circuit boards and assembly of the inserter.

Accession For	
NTIS GRA&I	<input checked="" type="checkbox"/>
DTIC TAB	<input type="checkbox"/>
Unannounced	<input type="checkbox"/>
Justification	
By _____	
Distribution/ _____	
Availability Codes	
Dist	Avail and/or Special
A	



1. INTRODUCTION

This technical report describes the design, interface, and operation of a general purpose raster scan display Color Video Inserter (CVI) which is capable of airborne operation. The CVI is divided into two independent functions, a color inserter section and a synchronization generation and distribution section. The color inserter which operates on standard red, green, and blue (RGB) color signals will select one of two background video inputs for display on up to three color monitors and inset into the background externally generated dynamic color features, fixed color features, or both. There is also a separate monitor output to display only the color inset features. The synchronization generation and distribution section is capable of internal generation of television synchronization signals and distribution of these signals to six external users. There is also an external mode in which the synchronization circuitry operates as a distribution amplifier providing six outputs for each of three inputs from an external master synchronization source. Figure 1 shows the front panels of both the CVI and the control units. All input and output lines and control functions are located on these two panels.

2. INTEGRATED MISSION PLANNING STATION (IMPS)

The CVI will be an integral part of an Integrated Mission Planning Station (IMPS). The mission planning station will be used to support the Night Navigation and Pilotage System (NNAPS). A block diagram of the IMPS station with the CVI is shown in Figure 2.

The NNAPS system is being developed to provide a significant improvement in the safety of nap-of-the-earth (NOE) flight, especially during times of limited visibility. Presently, flight map reading is performed manually with the copilot reading the map and giving directions to the pilot. The required reaction time for NOE flight is very short, making this type of mission very dangerous. The NNAPS approach is to develop a computer driven electronic color map display using a standard cathode ray tube (CRT). Digital topographic data for a large geographic area is stored on a tape cassette and the desired portion of that data is displayed on a cockpit display. This color map display will be used for pre-flight tasks, such as mission planning, and in-flight will provide the aviator with a means of selectively displaying key flight data. Navigational accuracy can also be improved by a terrain correlation scheme based upon the digital elevation data which is also utilized to generate the topographic display. Symbology generation is another aspect of the system and consists of the symbology associated with the topographic display as well as flight control symbology.

The IMPS will primarily be used to prepare specific mission tape cartridges for use in the aircraft. Other functions of IMPS include mission planning assistance to the aircrew and verification of mission planning via simulated flight over chosen ground tracks. The IMPS support software and some of the Government furnished equipment (GFE) is being developed under contract. The CVI was designed and fabricated in-house and will be supplied to the contractor as GFE for integration into the IMPS system at the contractor's facility. The final testing and evaluation of the system will be at the AVRADA Avionics System Simulation Facility at Fort Monmouth, NJ.

Referring to Figure 2, the CVI accepts background map data from the Digital Map Generator (DMG) and insets onto the background map features from two sources, the DeAnza Color Feature Generator and the Avionics Symbology Generator. The final video output, as display outputs 1 and 2, respectively, is presented on the two color television monitors. The inset display output from the CVI goes to a third monitor on which only the video from the two inset sources can be observed. An additional

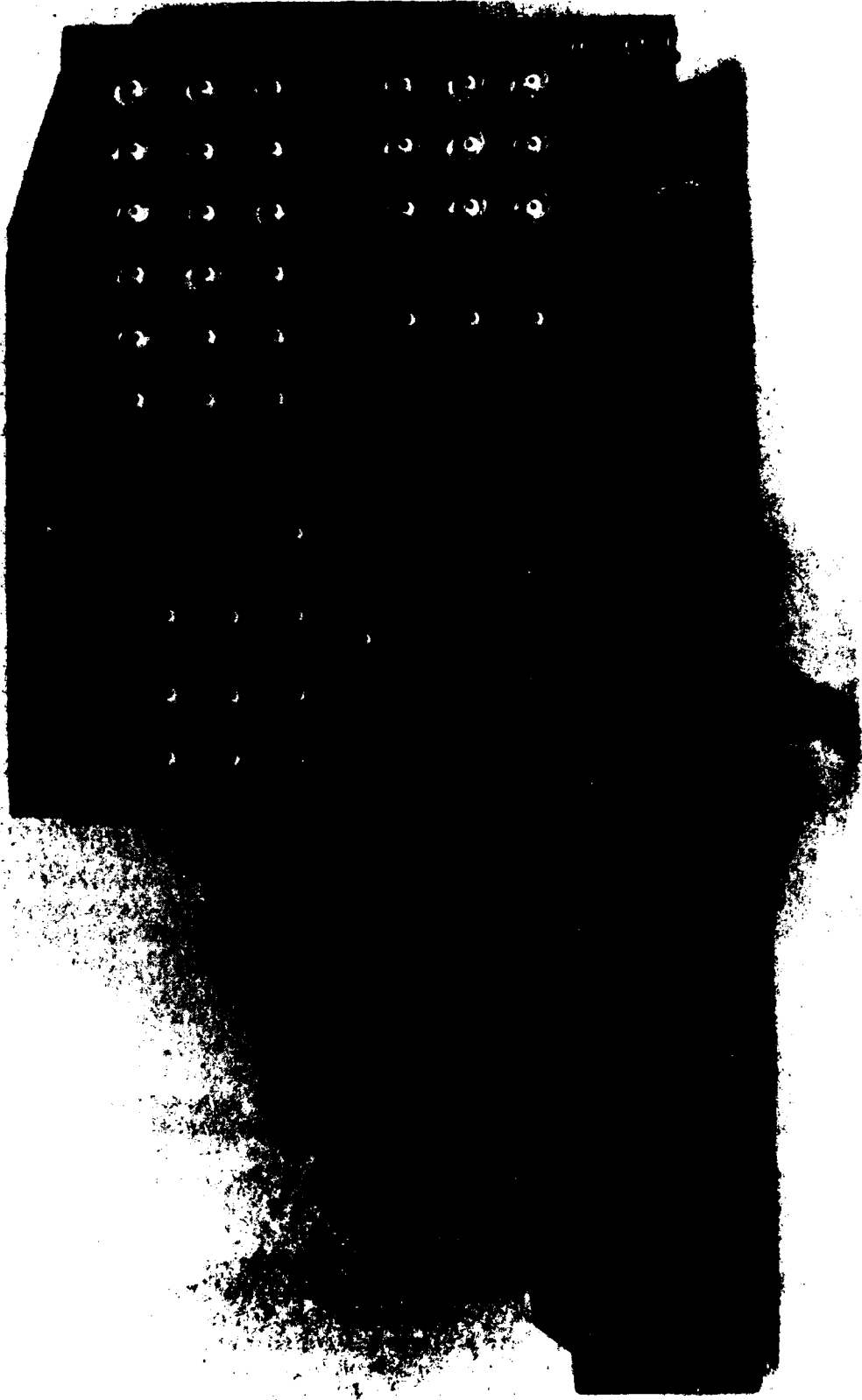

Figure 1. Color Video Insetter.

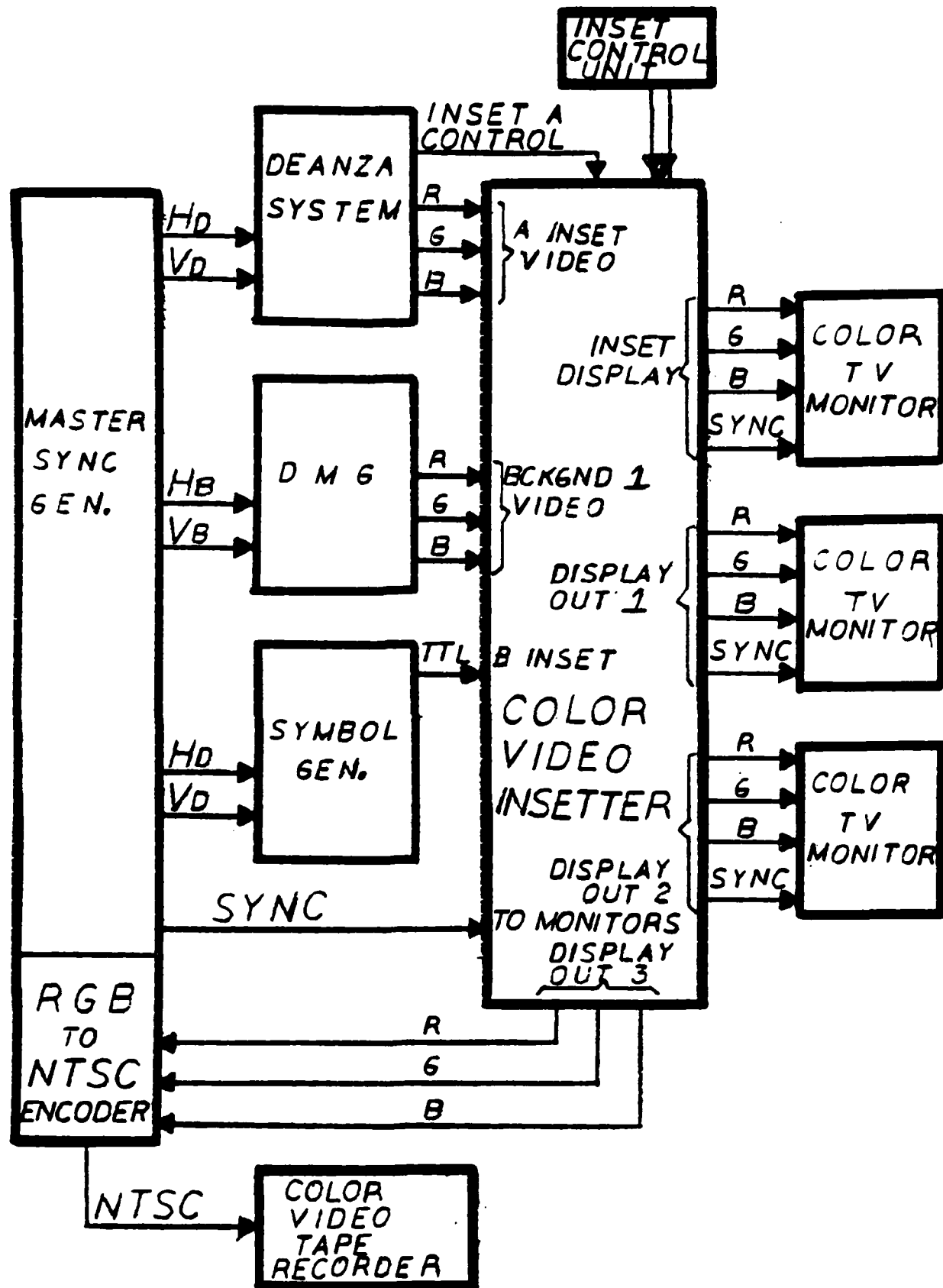

Figure 2. Block diagram of Integrated Mission Planning Station.

display output from the CVI is routed to the RGB to NTSC video encoder for recording on the tape recorder in National Television System Committee (NTSC) format. The master synchronization generator generates all necessary synchronization signals. There is also a remote control unit which permits remote operation of the video inserter. The three other major equipments in the IMPS station are as follows:

a. Digital Map Generator. From a stored digital data base, the DMG can generate terrain elevation data in the form of slope-shaded terrain images with overlaid contour lines of selectable interval spacing. As an alternative mode, elevation shading in selectable intervals can be displayed. In addition, planimetric data (e.g., forests, cities, rivers, roads, railroads, point features) can be selectively displayed in color upon the background elevation display. The display is capable of translation and rotation in response to aircraft motion.

b. DeAnza Color Feature Generator. The DeAnza system provides a flexible graphic display generation capability to complement the DMG. It provides an overlay of additional tactical features in color such as roads, obstacles, wires, and other logistical data which is inset into the DMG background map.

c. Avionics Symbology Generator. The symbology generator dynamically generates alphanumeric and alphanumeric data pertinent to aircraft flight which are inset into the background map. Typical of the symbology are: airspeed, altitude, heading, pitch attitude, roll attitude, vertical rate of climb, turn angle, bank angle, and course.

4. REQUIREMENTS

The CVI is required to perform the following as part of an integrated display system:

a. Accept one of two video inputs in RGB format for background video. Input 1 will be from a DMG and input 2 will be for future use.

b. Inset into the background video up to two additional sources of externally generated features. The first source will be in an RGB video format and come from the DeAnza Color Feature Generator. A control line is also required from the DeAnza to indicate the presence of inset data, with 0V = No Pixel and +0.7V = Valid Pixel data. The second source will be the Avionics Symbology Generator and will be connected to the CVI through a differential TTL twisted-pair control line. The color of the inset features from the second source will be determined by separate potentiometers for the red, green, and blue primary colors that are located on the front panel of the CVI. The CVI will display data from the second inset source if data from the first source arrives simultaneously.

c. Provide three identical video display outputs in an RGB format for the recording combined video. Two sources will be used for driving color television monitors and one for driving an RGB to NTSC converter.

d. Provide a separate RGB output to display the inset features on a separate color monitor.

e. All inputs and outputs must be terminated in, or capable of, driving 75-ohm loads.

f. A small remote control unit must be provided to permit selection to the background video source, inset source, and inset display.

g. The CVI shall not require any synchronization signals.

h. Provide a stand alone synchronization generator as a convenience. The CVI will provide six outputs of horizontal drive, vertical drive, and composite synchronization each capable of driving a 75-ohm load. There must also be an external operational mode for the synchronization generator for use as a distribution amplifier providing six outputs for each of three synchronization inputs. The synchronization generator will have no internal connections to the insetter and can be used as an optional hardware item if required by the display system configuration.

4. CIRCUIT DESCRIPTION

All input and output lines and control functions are located on these two panels. A block diagram of the CVI circuitry is shown in Figure 3. The signal input connectors are located on the upper left-hand part of the CVI front panel. There are inputs for two sources of background video which enter in a three line RGB format. The background video is fed to electronic switches which select one of the two sources for display. The control of these switches is accomplished through the setting of the background select switch located on the control unit which permits the video to be turned off, or sources one or two to be selected for display. The selected background video is then fed through a display multiplexer to the display output drivers which provide three sets of RGB outputs capable of driving the 75-ohm inputs of color television monitors. The display outputs are located on the lower right-hand corner of the CVI front panel. There are two sets of inset input signals, inset A and B, respectively.

The A inset channel consists of RGB video inputs and a separate control input. The data for these inputs is intended to come from the DeAnza color generator and will consist of dynamic RGB video data which represent display features along with a control signal to determine when the data is to be inset onto the display. To operate the A inset, the control unit inset selector switch should be set to the A position. This sets the inset multiplexer to the A input to permit the routing of the A signal RGB data to the display multiplexer. When the A inset control signal is present, the threshold detector changes state and permits the A data to be inset into the background video by the display multiplexer. The B inset commands are intended to come from the Avionics Symbology Generator and will generally consist of symbology and alphanumerics. To operate the B inset, the inset selector switch should be set to the B position which activates the B line receiver and sets the inset multiplexer to route the three B color select potentiometers located on the CVI front panel to the display multiplexer. Upon command from the B input, the display multiplexer in the CVI insets a fixed color onto the background video which is determined by the setting of the three B inset color-select potentiometers.

When the inset control is set to the A+B mode, both the A and B inset inputs are activated and inset features onto the background video. If both the A and B inset signals are active at the same picture element (pixel) location in the display, the B input will override the A input and place the B inset color onto the display for that pixel. There is also an inset data monitor function. The A inset RGB data and control along with the B inset commands are routed to the inset monitor output which has RGB outputs for driving a separate inset display monitor. The inset monitor function permits the A and B inset information to be observed for reference purposes on a separate television monitor in accordance with the setting of the inset display function switch located on the control panel.

Figure 4 is a block diagram of the synchronization generator and distribution circuitry. This circuit function provides an internal synchronization generator capable of generating television synchronization signals and distributing these signals to

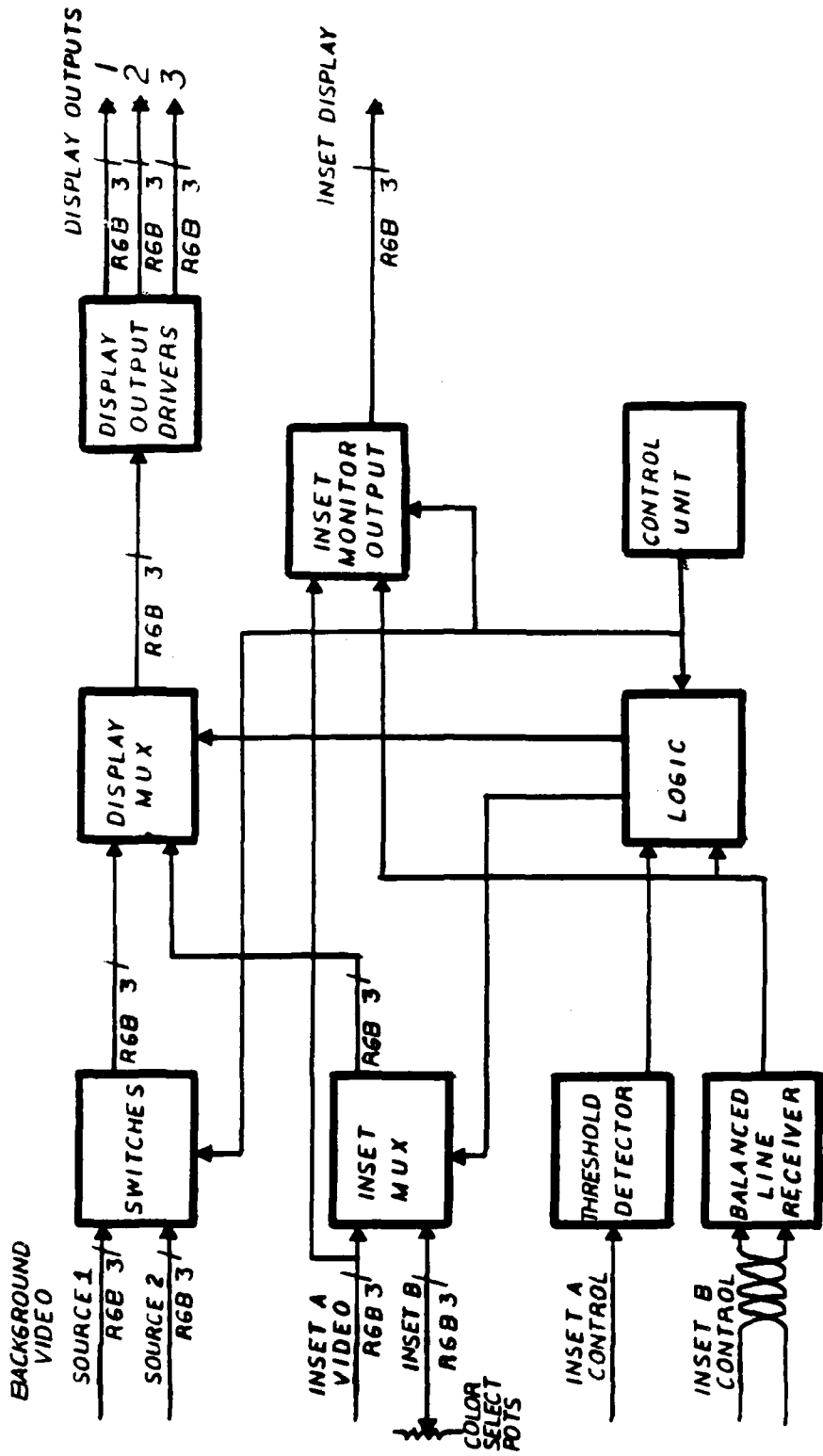

Figure 3. Block diagram of CVT circuitry.

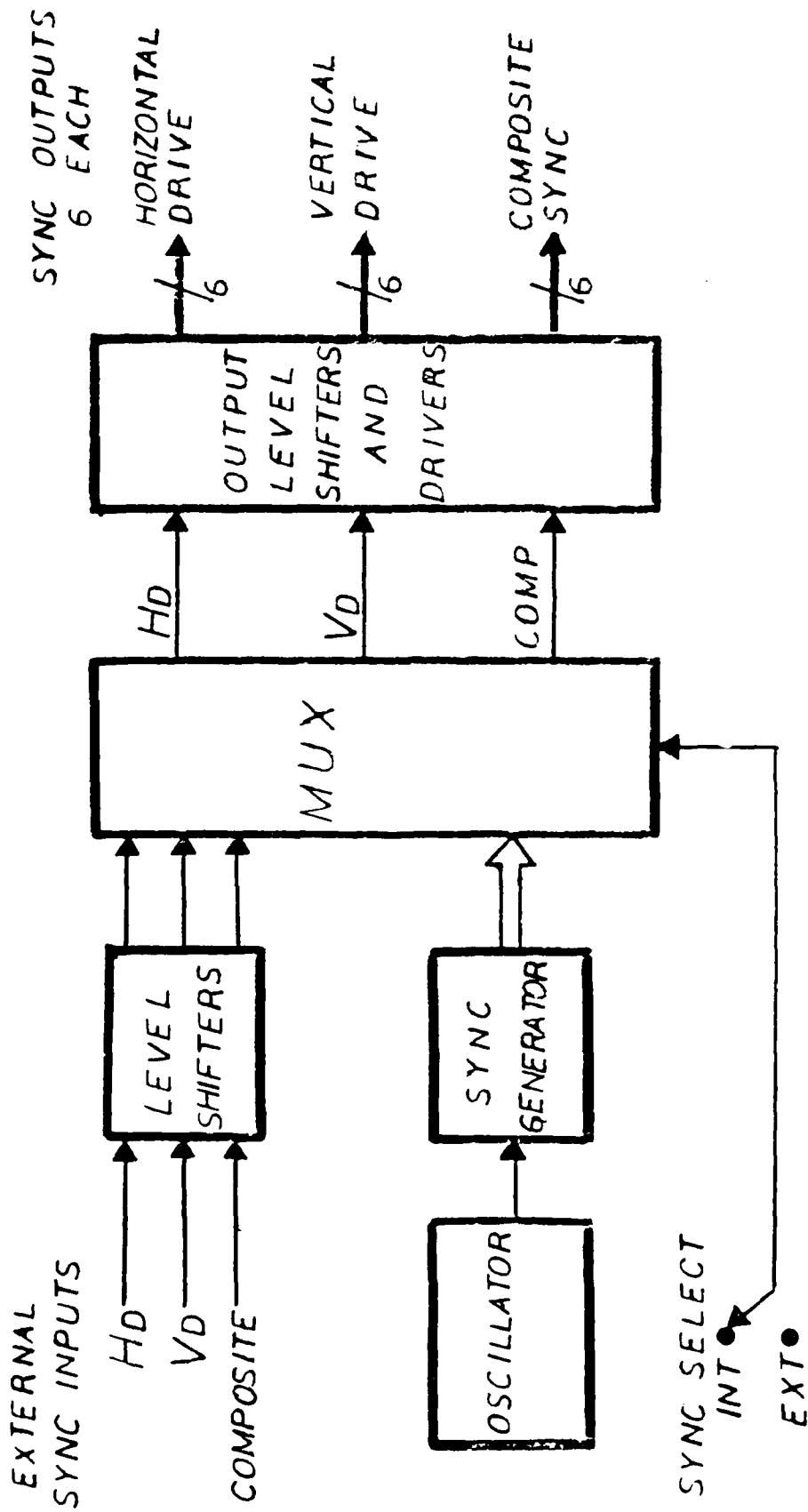

Figure 4. Block diagram of Synchronization Generator and Distribution circuitry.

a maximum of six external users. There is also an external mode in which the synchronization circuitry operates as a distribution amplifier providing six outputs for each of three master synchronization source inputs. The synchronization switch located on the CVI front panel determines the operating mode of the synchronization circuitry. In the internal mode, the synchronization generator functions as the master source of synchronization signals. An internal oscillator drives the synchronization generator which provides horizontal drive, vertical drive, and composite sync (including) signals. Each of these signals is fed to six respective level shifters which shift the signals to EIA levels and provide 75-ohm drive capability for distribution to external users. In the external mode, the external synchronization signals at EIA levels are input to level shifters to shift the signals to TTI levels and then to the multiplexer which feeds the signals to the output level shifters and drivers for external distribution. All electrical inputs and outputs for the synchronization generator are located on the CVI front panel.

5. OPERATION

The following is a description of the operation of the CVI controls. For the location of the controls, refer to Figure 1.0.

<u>CONTROL NAME</u>	<u>DESCRIPTION</u>
Background Select Switch	Turns the background video off, or selects video source and/or type to be routed to the display output.
Inset Select Switch	determines the feature source that will be inset into the background video.
	OFF - turns all inset sources off.
	A - selects the dynamic color features from inset source A which will be the DeAnza Color Generator. The color, location, and feature size is determined by data from the DeAnza Generator.
	B - selects the static color features from inset source B which will be the Avionics Symbol Generator. The color of features is determined by the setting of the three B inset color potentiometers located on the CVI front panel and the location and size determined by data from the Avionics Symbol Generator.
	A+B - both A and B inset sources are active and inset features onto the background video. If both A and B inset signals are active at the same pixel location in the display, the B input will override the A input and place the B inset color onto the display for that pixel location.
Inset Display	Selects the source of inset video to be displayed on the inset monitor, source A or B.

<u>CONTROL NAME</u>	<u>DESCRIPTION</u>
Sync (Select) Switch	When set to the internal mode, the synchronization generator functions as a master source of synchronization. Signals are output on the horizontal drive, vertical drive, and composite synchronization outputs. In the external mode, the synchronization generator functions as a distribution amplifier for an external master source connected to the external synchronization inputs.
B Inset Color Select Potentiometers	Set the color of the fixed color features from the B inset input.
Power Requirement	120 V ac, 0.5 amperes, 60 Hz. The power supply design is of modular construction, and with minor reconfiguration, a 28-volt dc converter can be incorporated to permit operation on board aircraft.

6. INTERFACE REQUIREMENTS

a. Inputs

(1) Background video

Red, Green, Blue Inputs

Voltage levels -----	white -----	0 volts
	black -----	-0.7 volts
Impedance -----		75 ohms
Time delay (input to display outputs) -----		75 ns

(2) Inset A (DeAnza color generator input)

Red, Green, Blue Video

Voltage levels -----	white -----	+0.7 volts
	black -----	0 volts
Impedance -----		75 ohms

Control input

Voltage levels

Pixel present -----		+0.7 volts
No pixel present -----		0 volts
Impedance -----		75 ohms
Time delay (control input to display output) -----		45 ns

(3) Inset B (Avionics Symbology Generator)

Control input ----- Differential line receiver, AMD type Am 26LS33, typical 2.5-volt differential TTL input signal into a 120-ohm termination.

Color levels ----- Red, Green, Blue set by potentiometers located on CVI front panel.

Time delay (Control input to display output) ----- 80 ns

(4) Sync Inputs (Horizontal Drive, Vertical Drive, Composite Sync)

Voltage level ----- (EIA Standard) -6 volts

Impedance ----- 75 ohms

5. Outputs

(1) Display Outputs and Inset Display (Red, Green, Blue)

Voltage level ----- white ----- +0.7 volts

Black ----- 0 volts

Output drive ----- can drive a 75-ohm load

(2) Sync Outputs (6 each, Horizontal Drive, Vertical Drive, Composite Sync)

Voltage level ----- (EIA Standard) -6 volts

Output drive ----- can drive a 75-ohm load

7. FABRICATION

A commercially available ATR inclosure was used to house the CVI circuit boards. A total of six printed circuit boards, 17.5 by 25 cm (7 by 10 inches) was utilized to perform the required functions. The circuit board functions are:

Input Interface

Video Multiplexer

Display Output Drivers

Input Video Output

Synchronization Generator and Distribution

Synchronization Generator Clock

Commercially available linear and digital integrated circuits were used in the circuit board assemblies which were fabricated using custom layout techniques. All circuit boards are custom layouts. Figure 5 shows the CVI with the Video Multiplexer and Synchronization Generator and Distribution printed circuit boards in front. The CVI power supply was fabricated with commercially available power modules and operates from a 120-V ac, 60-Hz power source. Due to the modular design,

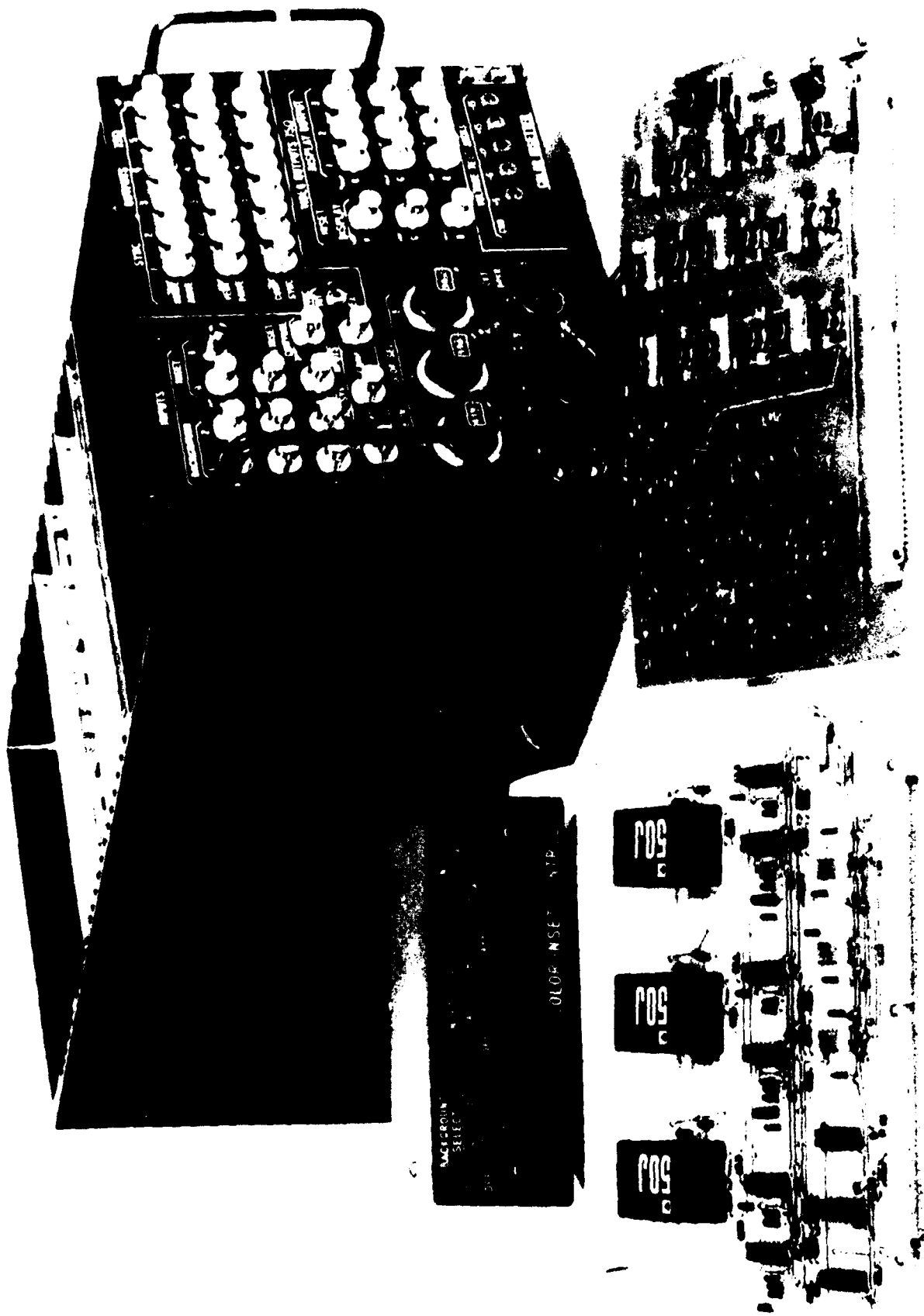

Figure 5. Color Video Inserter with printed circuit boards.

the power supply can be reconfigured with a 28-volt dc converter to permit operation on board aircraft. The front panel of the CVI contains all electrical connections to the CVI. The Control Unit is a separate box which can be remoted by means of a 10-foot cable from the insetter ATR inclosure. Not shown is a fan housing which can be placed on top of the ATR inclosure to cool the circuitry if required by ambient conditions in an uncontrolled environment. The fan housing is available with 120-V ac, 60-Hz fans or 120-V ac, 400-Hz fans for aircraft use.

8. TEST RESULTS

The CVI was successfully operated in the laboratory for electrical test purposes and also with an avionics map display system similar to the IMPS station of Figure 2. Terrain maps were generated by the computer and features symbology generated by the associated peripheral equipment. Typical photographs of terrain maps with and without inset features and symbology are shown in Figures 6 through 9. The features and symbology are shown separately in Figures 10, 11, and 12. The photographs in this report can only be shown in black and white; however, in actual practice both the maps and inset features can be displayed in color or black and white. Figures 13 through 22 illustrate the electrical performance achieved in the laboratory by the CVI. Figure 13 shows the display output time delay and pulse shape resulting from a background video pulse input. Figures 14 through 18 show the display output wave-forms resulting from a background video pulse input and various combinations of A and B inset pulses occurring during the black portion of the background video. Figures 19 through 22 are similar to the previous photographs but with the inseting occurring during the white portion of the background video.

9. CONCLUSIONS

A general purpose Color Video Insetter for raster scan displays which is capable of airborne operation has been designed and fabricated. The insetter has been successfully evaluated in the laboratory with computer-generated maps and symbology and has met all design requirements. The extensive use of microelectronic circuitry has made feasible the fabrication of the insetter and its packaging into an airborne enclosure.



Figure 6. Computer-generated map display.



Figure 7. Map with terrain contours on A inset.

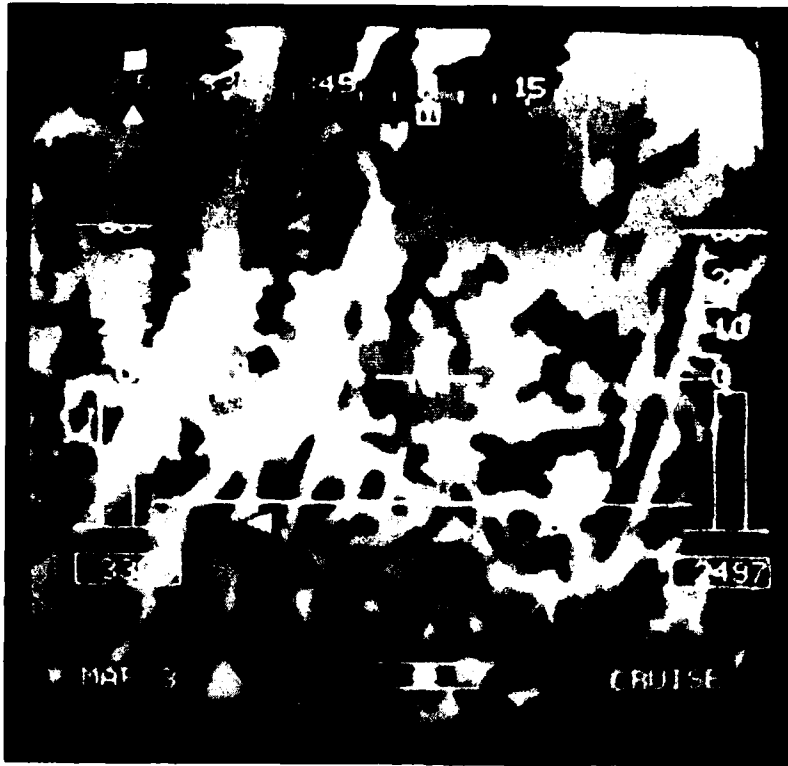

Figure 8. Map with avionics symbology on B inset.



Figure 9. Map with terrain contours and avionics symbology.

Copy available to DTIC does not
permit fully legible reproduction

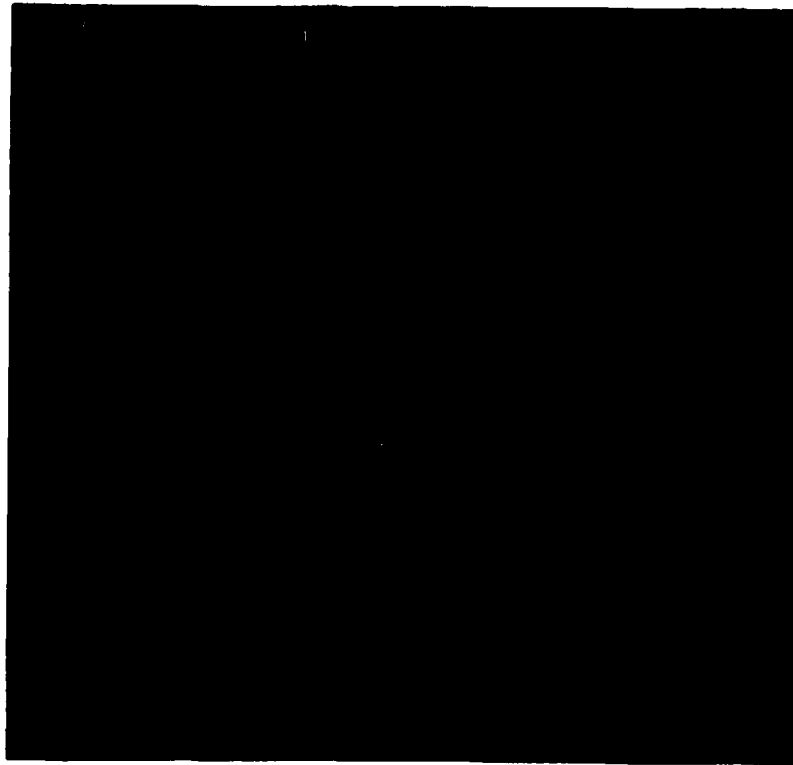

Figure 10. Inset display with contours on A inset.

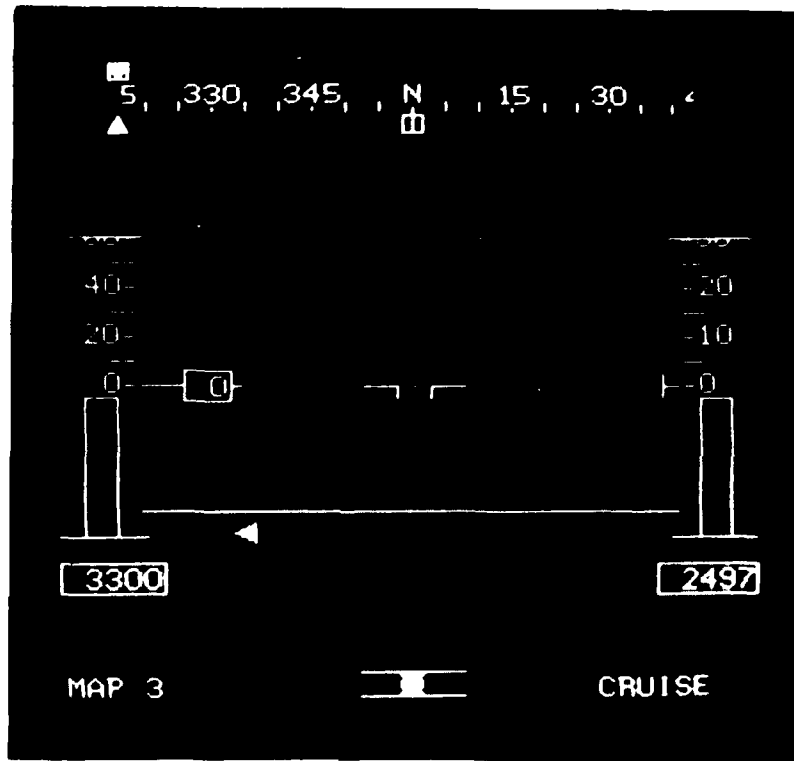

Figure 11. Inset display with avionics symbology on B inset.

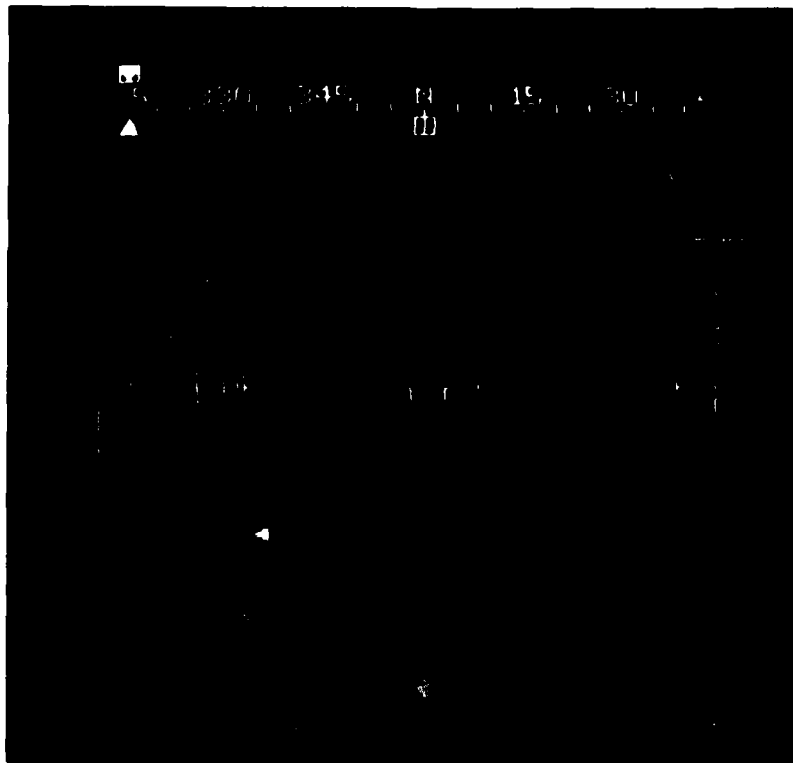

Figure 12. Inset display with contours and avionics symbology.

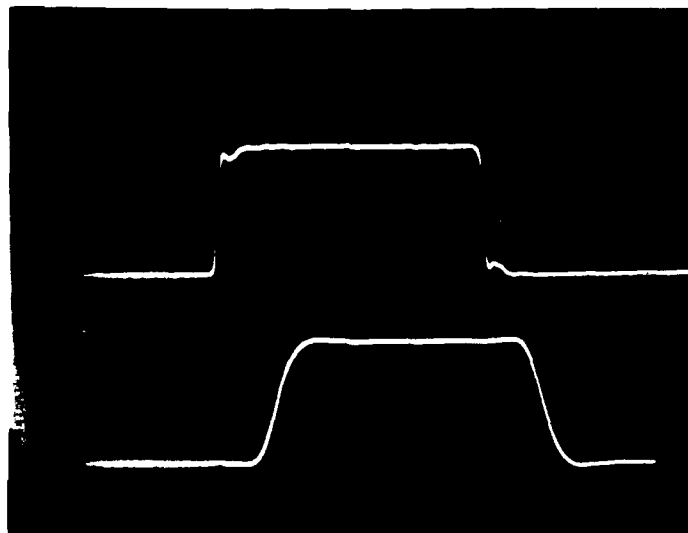

Figure 13. Display output with background video .
 Top - Background video input 0.5v/div
 Bottom - Display output 0.5v/div

Time base 50 ns/div

Copy available to DOD does not
 permit fully legible reproduction

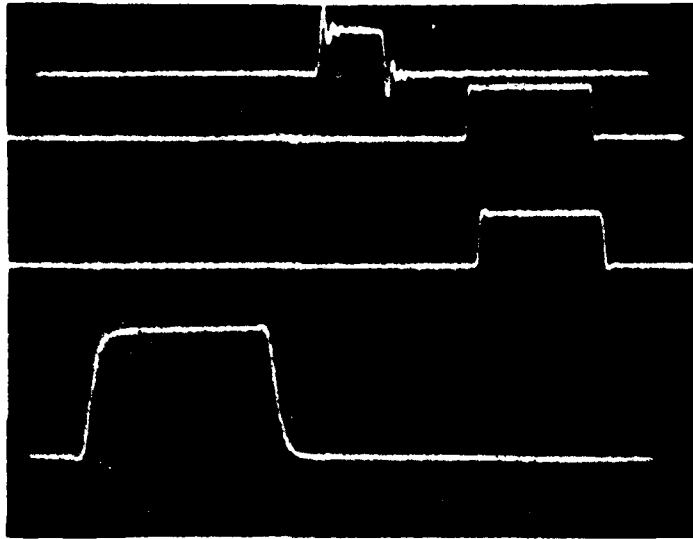

Figure 14. Display output with background video.
1st - Inset B input 2 v/div
2nd - Inset A control input 1 v/div
3rd - Inset A data 1 v/div
4th - Display output 0.5 v/div

Time base - 100 ns/div

Inset Select set to OFF

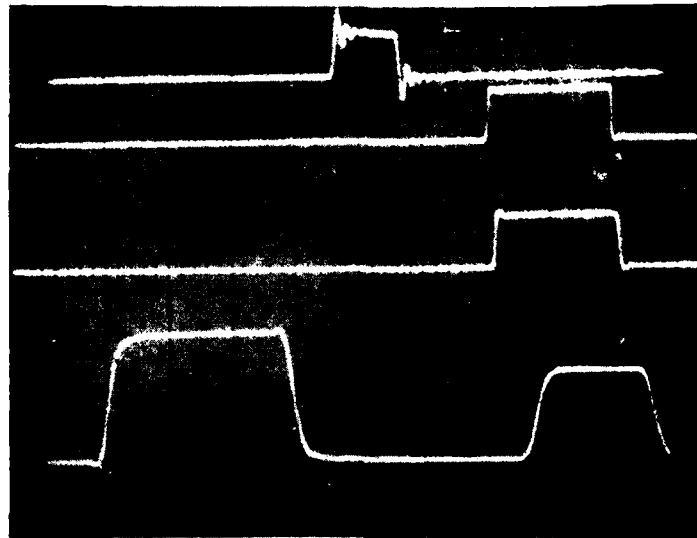

Figure 15. Display output with background video and A inset.

- | | |
|-----------------------------|-----------|
| 1st - Inset B input | 2 v/div |
| 2nd - Inset A control input | 1 v/div |
| 3rd - Inset A data | 1 v/div |
| 4th - Display output | 0.5 v/div |

Time base - 100 ns/div

Inset Select set to A

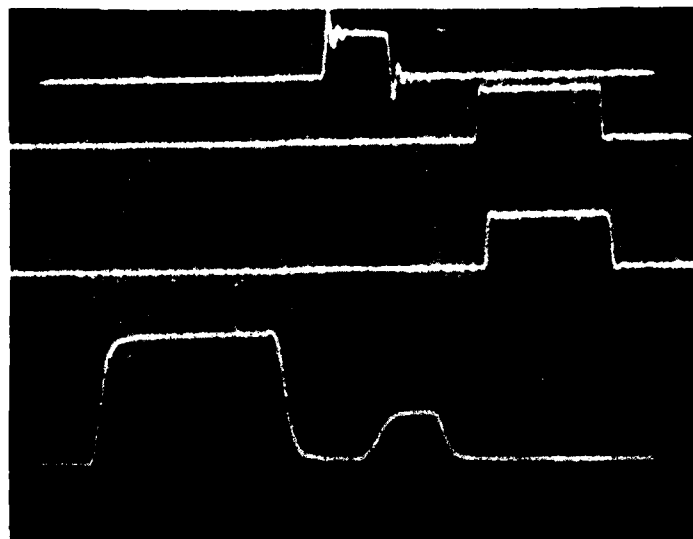

Figure 16. Display output with background video and B inset.

1st - Inset B input	2 v/div
2nd - Inset A control input	1 v/div
3rd - Inset A data	1 v/div
4th - Display output	0.5 v/div

Time base - 100 ns/div

Inset Select set to B

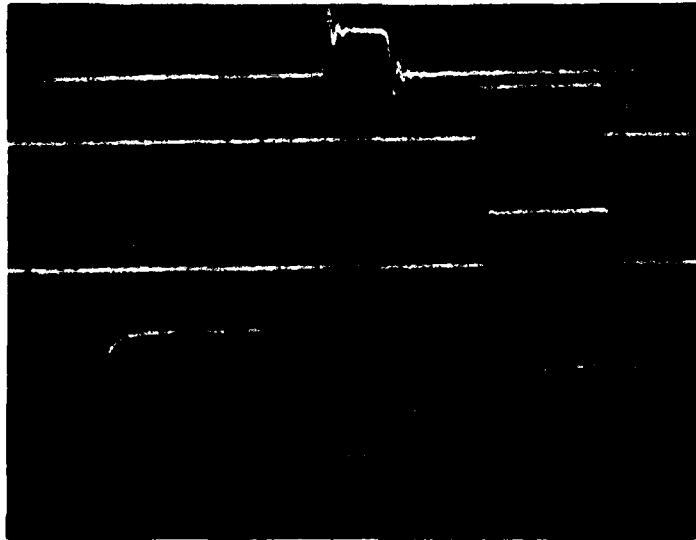

Figure 17. Display output with background video and A and B inset.

1st - Inset B input	2 v/div
2nd - Inset A control input	1 v/div
3rd - Inset A data	1 v/div
4th - Display output	0.5 v/div
Time base - 100 ns/div	

Inset Select set to A and B

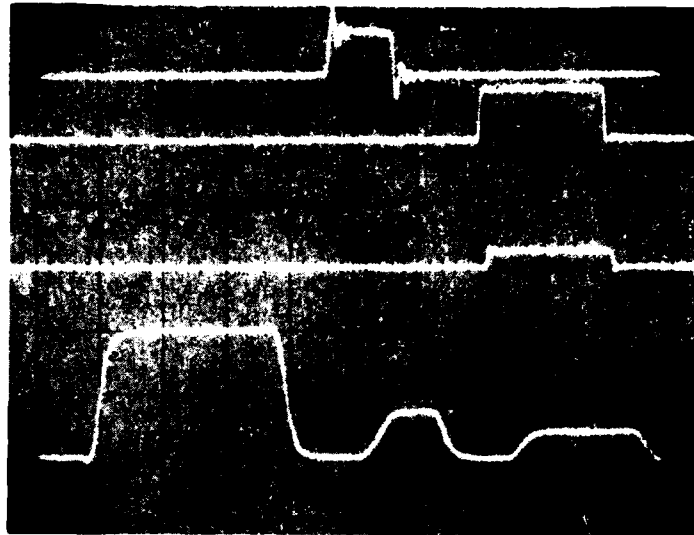

Figure 18. Display output with background video and low level A and B inset.

1st - Inset B input	2 v/div
2nd - Inset A control input	1 v/div
3rd - Inset A data	1 v/div
4th - Display output	0.5 v/div

Time base - 100 ns/div

Inset Select set to A and B

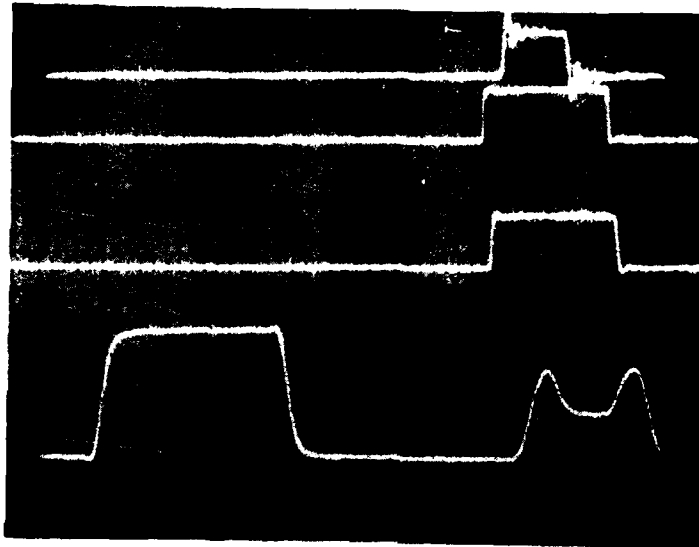

Figure 19. Display output with background video and B over A inset.

1st - Inset B input	2 v/div
2nd - Inset A control input	1 v/div
3rd - Inset A data	1 v/div
4th - Display output	0.5 v/div

Time base - 100 ns/div

Inset Select set to A and B

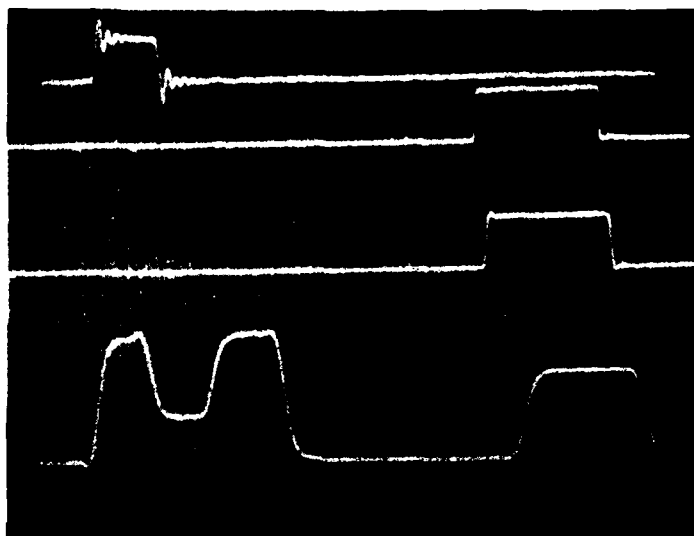

Figure 20. Display output with B inset over background video.

1st - Inset B input	2 v/div
2nd - Inset A control input	1 v/div
3rd - Inset A data	1 v/div
4th - Display output	0.5 v/div

Time base - 100 ns/div

Inset Select set to A and B

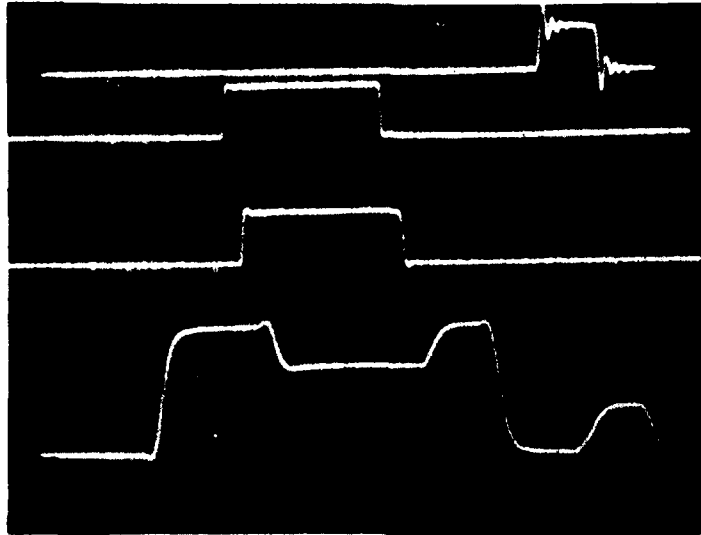

Figure 21. Display output with A inset over background video.

1st - Inset B input	2 v/div
2nd - Inset A control input	1 v/div
3rd - Inset A data	1 v/div
4th - Display output	0.5 v/div

Time base - 100 ns/div

Inset Select set to A and B

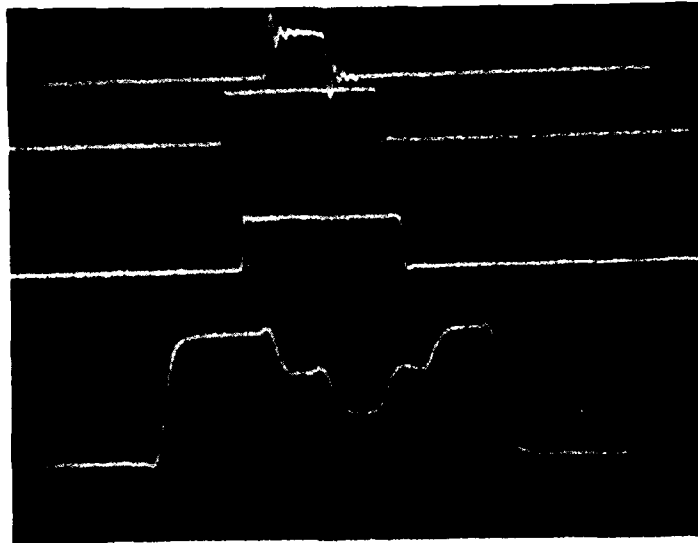

Figure 22. Display output with A and B inset over background video.
1st - Inset B input 2 v/div
2nd - Inset A control input 1 v/div
3rd - Inset A data 1 v/div
4th - Display output 0.5 v/div

Time base - 100 ns/div

Inset Select set to A and B

END

FILMED

9-83

DTIC