

AD-A132 233

**TECHNICAL
LIBRARY**

AD

AD-E401 062

TECHNICAL REPORT ARLCD-TR-83011

FIRE RETARDANT TREATMENTS FOR AMMUNITION PACKAGING

**ROBERT L. FORTUNATO
HARRY J. REEVES**

AUGUST 1983



U.S. ARMY ARMAMENT RESEARCH AND DEVELOPMENT CENTER

LARGE CALIBER WEAPON SYSTEMS LABORATORY

DOVER, NEW JERSEY

APPROVED FOR PUBLIC RELEASE; DISTRIBUTION UNLIMITED.

The views, opinions, and/or findings contained in this report are those of the author(s) and should not be construed as an official Department of the Army position, policy, or decision, unless so designated by other documentation.

The citation in this report of the names of commercial firms or commercially available products or services does not constitute official endorsement by or approval of the U.S. Government.

Destroy this report when no longer needed. Do not return to the originator.

THIS DOCUMENT CONTAINED
BLANK PAGES THAT HAVE
BEEN DELETED

UNCLASSIFIED

SECURITY CLASSIFICATION OF THIS PAGE (When Data Entered)

REPORT DOCUMENTATION PAGE		READ INSTRUCTIONS BEFORE COMPLETING FORM
1. REPORT NUMBER Technical Report ARLCD-TR-83011	2. GOVT ACCESSION NO.	3. RECIPIENT'S CATALOG NUMBER
4. TITLE (and Subtitle) FIRE RETARDANT TREATMENTS FOR AMMUNITION PACKAGING	5. TYPE OF REPORT & PERIOD COVERED Final 1979 to 1982	6. PERFORMING ORG. REPORT NUMBER
		8. CONTRACT OR GRANT NUMBER(s)
7. AUTHOR(s) Robert L. Fortunato Harry J. Reeves	9. PERFORMING ORGANIZATION NAME AND ADDRESS ARDC, LCWSL Munitions Systems Div [DRSMC-LCU-S-P(D)] Dover, NJ 07801	
11. CONTROLLING OFFICE NAME AND ADDRESS ARDC, TSD STINFO Div [DRSMC-TSS(D)] Dover, NJ 07801	10. PROGRAM ELEMENT, PROJECT, TASK AREA & WORK UNIT NUMBERS	
	12. REPORT DATE August 1983	13. NUMBER OF PAGES 52
14. MONITORING AGENCY NAME & ADDRESS (if different from Controlling Office)	15. SECURITY CLASS. (of this report) Unclassified	
	15a. DECLASSIFICATION/DOWNGRADING SCHEDULE	
16. DISTRIBUTION STATEMENT (of this Report) Approved for public release; distribution unlimited.		
17. DISTRIBUTION STATEMENT (of the abstract entered in Block 20, if different from Report)		
18. SUPPLEMENTARY NOTES		
19. KEY WORDS (Continue on reverse side if necessary and identify by block number) Ammunition cookoff Ammunition fire tests Ammunition fires Ammunition packaging Ammunition fire hazards Fire retardant packaging		
20. ABSTRACT (Continue on reverse side if necessary and identify by block number) <p>An analysis of fires at ammunition supply points showed that packaging materials were the main cause of the spread of fires. In the case of packaged tank and artillery ammunition, the external wooden box and the internal fiber container were major contributors to the ammunition fires.</p> <p>Described in this report is work performed to optimize fire-retardant treatment systems for ammunition packaging and to develop an end item pack.</p> <p style="text-align: right;">(cont)</p>		

20. ABSTRACT (cont)

The results of fire tests conducted on stacks of 105-mm tank ammunition packaged in fire retardant materials and the results of physical and exposure testing are also presented.

The results of these tests show that fire retardant packaging can be used to protect stacked ammunition by eliminating the spread of fire when one or more rounds in the stack is ignited without compromising the protection of rounds.

ACKNOWLEDGMENT

Recognition is given to Dr. Leonard Teitell for his effort in initiating this program at ARRADCOM and the direction and guidance he provided.

CONTENTS

	Page
Introduction	1
Packaging and Construction Materials	3
Fire Retardant Treatments for Wood	4
Approach and Test Methods	4
Laboratory Evaluation	5
Fire Retardant Treatments for Paper	7
Approach and Test Methods	7
Laboratory Evaluation	8
Field Tests on Fire Retardant Pack (Box and Fiber Container)	8
Cookoff Fire Test	8
Simulated Pallet Fire Test	9
Results	9
Laboratory Tests on Fire Retardants for Wood	9
Laboratory Tests on Fire Retardants for Paper	13
Field Tests on Fire Retardant Pack	14
Conclusions	16
Recommendations	17
References	19
Appendix - Results of Panama Exposure Tests	39
Distribution List	47

TABLES

	Page
1 Target ammunition characteristics	3
2 Results from ASTM crib tests conducted on wood cut from treated 105-mm wirebound boxes	11
3 Data for drop test sequence on 105-mm wirebound boxes	12
4 Results from surface burn tests	13
5 Results from compression tests on 6 1/4 in. fiber container sections tested to a 1-in. deflection	14
6 Results from cookoff fire test to determine insulating properties of treated packaging materials	15
7 Results from simulated pallet fire test	16

FIGURES

1 105-mm HEAT-T, M456 series	21
2 105-mm TP-T, M490	21
3 105-mm TP-T, M467	21
4 Wirebound box	22
5 Standard fibre container for 105-mm tank rounds	22
6 ASTM standard crib test for testing combustible properties of treated wood	23
7 Crib test performed on untreated wood--5 seconds before burner shutoff	24
8 Crib test performed on untreated wood--68 seconds after burner shutoff	24
9 Crib test performed on fire-retardant treated wood--5 seconds before burner shutoff	25
10 Crib test performed on fire-retardant treated wood--10 seconds after burner shutoff	25
11 Seven-day leaching test	26
12 Drop test series for fire-retardant wirebound box	27

13	Exposure site at Skunk Hollow	28
14	Exposure site at Chiva-Chiva	28
15	Surface burn test setup for paper products	29
16	Cookoff apparatus	30
17	Cookoff test setup	30
18	Pallet fire test	31
19	Crib test results for fire-retardant-treated wood	32
20	Progression of damage to a fire-retardant-treated box during the drop-test series	33
21	Fire-retardant-treated box after completion of the drop-test series	33
22	Progression of damage to an untreated box during the drop-test series	34
23	Untreated box after completion of the drop-test series	34
24	Untreated box after a 3-month exposure	35
25	Fire-retardant-treated box after a 3-month exposure	35
26	Results from a simulated pallet fire test using untreated packaging	36
27	Debris remaining after a simulated pallet fire test using untreated packaging	36
28	Results from a simulated pallet fire test using fire-retardant treated packaging	37
29	Intact rounds remaining after a simulated pallet fire test using fire-retardant treated packaging	37

INTRODUCTION

The vulnerability and safety problems associated with the transportation and storage of ammunition has been undergoing investigation by all three military services for many years. The results of these investigations have led to the formulation of quantity distance tables (QDT) that regulate the minimum permissible distance between a potential explosion site¹ containing a given quantity of explosives and an exposed site.² The QDT is based on an acceptable risk to life and property from the effects of a mass fire or an explosion in an ammunition storage area. However, in many situations in combat theaters, adequate land areas and security forces for the proper protection and storage of ammunition are not available. During the period of January 1966 through September 1971, the value of combined USARV and ARVN ammunition dump and ammunition supply point (ASP) losses exceeded \$146,000,000. This figure does not include losses suffered by other U.S. Forces, by other allies as a result of the ammunition's leaving a supply point, and other materiel losses associated with the storage and transportation of ammunition (buildings, trucks, barges, etc.).

Conventional artillery items, other than mass detonating types are normally shipped and stored in paperboard tubes and packed one or more rounds to a wooden box. If the packaging materials in a stack of ammunition are ignited, damage to the individual rounds can be expected in the form of cookoffs.³ The packaging can be ignited when either the propelling charge or high explosive filler of one or more rounds burns, explodes, or detonates, or the stack is exposed to an external heat source. Regardless of the mode of ignition, the wooden boxes and paperboard tubes currently used for packaging artillery ammunition can be the major factor in fire spread.

Preventive measures to reduce the fire hazard and limit overall losses include changes in the design of the ammunition, changes in storage procedures, and modification of packaging.

Studies have been conducted to evaluate the effectiveness of improved packaging in limiting the extent of fire damage to pallet sized configurations of either 81-mm mortar, 90-mm gun, or 105-mm semi-fixed howitzer ammunition (ref 1) or 155-mm propelling charges (ref 2) when the ammunition itself acts as the ignition source.

¹ The cavern, chamber, building, cell, or stack which contains or is intended to contain the ammunition and/or explosives under consideration.

² A magazine, cell, stack, truck, or trailer loaded with ammunition or explosives; a workshop, inhabited building, assembly place, or public traffic route which is exposed to the effects of an explosion (or fire) at the potential explosion site under consideration.

³ Cookoffs are the result of sufficient thermal energy transferred to the contained energetic materials to cause violent reaction or deflagration.

In the case of the mortar, gun, and howitzer study, the following conclusions were made:

1. Igniting the standard packaging materials in a stack of ammunition (fixed or semi-fixed) produces a conflagration with a loss of almost all of the ammunition.

2. Applying fire retardant intumescent paints to the surface of wooden boxes and paperboard tubes is only marginally effective in reducing overall losses.

3. Setting fire to packaging materials that have been fire-retardant treated by long duration burning high-explosive fires. However, if properly treated, they will eventually self-extinguish after the high-explosive fire goes out.

4. Treating both the wooden boxes and paperboard tubes must be completed if a fire retardant treatment is to be successful.

5. Improving the mechanical properties of the paperboard tubes can increase the effectiveness of fire-retardant treatments.

The following conclusions were reached in the 155-mm propelling charge investigation:

1. Subjecting 155-mm M4A2 propelling charges, in a multipallet open field storage configuration, to a direct hit by a large caliber high-explosive projectile produces a conflagration with a loss of almost all the charges. Damage will propagate via progressive cookoffs.

2. Painting the exterior surfaces of the metal shipping cans with an intumescent paint and/or chemically treating all combustible inner wrap materials so that they are fire retardant can improve (extend) the cookoff characteristics of the charges.

3. Improving the cookoff characteristics of the propelling charges can limit the extent of damage to multipallet stores when they are subjected to direct hits by large caliber high-explosive projectiles. However, the propelling charges, wooden pallets, and dunnage must all be treated if the effort is to be worthwhile.

4. Subjecting all evaluated treatments to a long duration heat source will cause them to thermally decompose because they continue to burn.

As opposed to past programs, an effort was made in these investigations to optimize a treatment system and develop an end item product. Besides being evaluated for their fire retardant and thermal conductivity properties, the treatments were also evaluated for other design parameters including mechanical and physical properties, durability including weathering and preservative qualities, producibility, and cost.

PACKAGING AND CONSTRUCTION MATERIALS

All 81-mm to 120-mm ammunition are currently packed in nailed wooden boxes with each round wrapped in a fiber container. The 81-mm rounds are packaged three per box with projectile ends alternating in position (head to base), the 90-mm and 105-mm rounds are packaged two per box with projectile ends in opposite directions, while the 120-mm rounds are packaged one per box. The representative rounds used in these tests were 105-mm tank training and 105-mm tank ammunition packed in wirebound wood boxes. Detailed descriptions of the rounds can be found in figures 1, 2, and 3 and table 1.

Wirebound wooden boxes, a possible alternate to nailed wooden boxes, are constructed in accordance with military specification MIL-B-46506C. These boxes consist of two sides and a top and a bottom, held together with galvanized binding wire secured with galvanized staples plus two cleated wooden ends. The boxes also have looped closures made from the ends of the galvanized binding wire and open at the top. Box dimensions vary according to the size of the ammunition to be packed (fig. 4).

The standard fiber container inner wrap consists of an outer tube, an inner support or neck tube, a cover tube, two crimped metal ends, and a plastic ammunition nose support. The closure is accomplished by sliding the cover tube onto the neck tube until it meets the outer tube and securing the seam with tape.

The outer tube, cover, tube and neck tubes are normally constructed from paperboard, asphalt coated on layered impregnated kraft paper, aluminum foil, and adhesive in accordance with military specification MIL-C-2439D (fig. 5). The fiber containers used for this test program, however, were modified so that all the paper products were replaced with special fire retardant paperboard. The exterior and interior surfaces of the outer, neck, and cover tubes were lined with a polyethylene, aluminum foil, and kraft paper laminate barrier material.

Table 1. Target ammunition characteristics

<u>Nomenclature</u>	<u>105-mm HEAT-T M456A1</u>	<u>105-mm TP-T M490</u>	<u>105-mm TP-T M467</u>
Length (in.)	39	39	37
Weight (lb)	48	45	45
Propellant (lb)	11.5 (M30)	11.5 (M30)	5.9 (M1)
Explosive (lb)	2.14 (Comp B)	N/A	N/A

FIRE RETARDANT TREATMENTS FOR WOOD

Approach and Test Methods

In the initial selection of fire retardant treatments for wood, most of those considered were applied with a pressure impregnation process. In the pressure treatment process, the fire retardant agent is forced into the wood under high pressure in a treatment chamber. Using this method it is possible to get large amounts (120 to 150 kg/m³) of the fire retardant agent into the wood with good penetration, depending on the type of wood being treated. Good penetration is considered an important characteristic because, in an actual ammunition fire environment, a great deal of splintering of the wood ammunition boxes takes place during ammunition reactions. The splintering exposes areas of untreated wood which act as fuel unless the treatment has a thorough penetration.

Some fire-retardant-dip treatments and coatings were also considered but were not as desirable as the fire retardant impregnants because of their lack of agent penetration.

Other parameters considered important in the selection of a candidate fire retardant are:

1. Leach resistance
2. Effect on wood structural properties
3. Effect on durability of the wood
4. Preservative qualities

The three different pressure impregnated, fire retardant treatments for wood selected for testing and evaluation included Flame-Proof, a product of Osmose Wood Preserving Company of America, Inc., NCX, a product of Koppers Company, Inc., and Fire-X 325, manufactured by Hoover Universal, Inc.

Flame-Proof

An interior grade fire retardant, Flame-Proof's primary constituents are ammoniated inorganic salts which are hygroscopic and pick up water at high humidities. Therefore, this treatment is limited to interior use unless a sealant is applied to the wood after treating.

NCX

NCX is an exterior grade fire retardant whose primary constituent is a salt resin which is relatively insoluble in water.

Fire-X 325

Fire-X 325 is an exterior grade fire retardant composed of urea, formaldehyde, and phosphates as a polymer which is formed in the wood during the pressure impregnation process.

All three fire retardants work basically the same way in their reaction to fire. The fire retardant salts react with the combustible gases and tars and convert them to carbon char, carbon dioxide, and water. The increased char produced acts as a heat insulator while the additional water vapor given off cools the wood.

Laboratory Evaluation

Crib Fire Testing

Initial evaluation and screening of different fire retardant treatments for wood was accomplished with a laboratory scale crib fire test.⁴ The crib test was used because it is the most stringent of laboratory fire tests and most representative of an ammunition fire situation.

To perform the tests, specimens are cut from the treated wood, stacked in a metal lattice crib, set on a scale, and then subjected to a burner flame for 3 minutes (fig. 3). Weight-loss versus time-data and burn-time of the wood are recorded after removal of the burner flame.

When the crib test is performed on untreated wood or wood treated with a poor fire retardant,⁵ the wood will be completely consumed within 10 minutes (figs. 7 and 8). The treated wood, however, will usually take longer to ignite, but once ignited will burn like untreated wood. Results indicative of a good fire retardant⁶ would be a wood weight loss of less than 10% and a burn time of one minute or less after the burner is shut off (figs. 9 and 10).

⁴ ASTM Standard E160 Crib Test for Testing Combustible Properties of Treated Wood.

⁵ Will continue to burn after exposure to an extended duration, high temperature of 1200° to 2000°F, heat source.

⁶ Will self-extinguish after exposure to an extended duration, high temperature of 1200° to 2000°F, heat source.

Leach Testing

To determine the leach resistance of the fire retardants, a laboratory leaching test⁷ was used. The test was very severe compared to rain tests usually conducted on treated materials, but was considered necessary due to the possible extended uncontrolled storage of ammunition in adverse environments. The leaching test was performed by submerging the treated wood specimens in 4000-mL vessels filled with water with an equivalent continuous water flow rate of five water changes per hour or 20,000 mL/hr (fig. 11). After seven days the wood was removed, air dried, and then subjected to the crib test.

Physical Testing

The comparative physical properties of the treated versus the untreated boxes were determined by subjecting boxes treated with various fire retardants and untreated boxes to a destructive drop-test series (fig. 12). The drop test plan in accordance with Picatinny Drawing 8837375 specifies the following procedure:

1. Four flat drops on four different surfaces from 3 feet
2. Four flat drops on four different surfaces from 2 feet
3. Four 45-degree corner drops on four different corners

In addition, a 7-foot flat drop, and a 7-foot 45-degree corner drop were added to the drop test series to increase the chances that there would be damage to the boxes for comparative analysis. This test plan is more severe than the standard U.S. Army Test and Evaluation Command (TECOM) drop testing which new ammunition packaging is subjected to for safety acceptance.

Unfortunately, the treated boxes were constructed from plywood inferior to the plywood used for untreated boxes, therefore, making a true comparative analysis difficult. "The National Design Specification for Stress Grade Lumber and Its Fastenings," recommended by the National Forest Products Association, states that "the allowable unit stresses in lumber pressure impregnated with fire retardant chemicals shall be reduced 10%. The same reduction shall be applied to the tabulated loads for fastenings."

⁷ Method 5830 from Federal Specifications Standard Test Methods for Textiles for Leaching Resistance of Cloth.

Preservative Testing

Information obtained from the data sheets of some of the fire retardants indicated that the treatments also provided protection against microbiological decay and termite attack. To determine the effective preservative qualities, the fire retardant treatments were exposed to a natural tropic environment. The test sites were the same as those used for MACI Project 5800976, Non-Tropic Preservative Treatments for all Wooden Army Products. A similar test and evaluation plan was also used.

The test plan called for the exposure of the boxes at two different sites in Panama, Skunk Hollow (Fort Sherman), a triple-canopy mature tropic rain forest and Chiva Chiva, an open field tropic area (figs. 13 and 14). The boxes were to be observed for biological degradation at regular intervals for a period of 1 year at which time samples cut from the boxes would be subjected to a crib test.

FIRE RETARDANT TREATMENTS FOR PAPER

Approach and Test Methods

Selection of a fire retardant treatment for the paper products used in the construction of fiber containers was accomplished using three parameters, fire retardance, produceability, and fiber container construction feasibility.

The first of the two treatments considered was diammonium phosphate. The paperboard to be tested was immersed in a neutralized diammonium phosphate solution containing 17.5 parts diammonium phosphate $(\text{NH}_4)_2\text{HPO}_4$, 2.4 parts (85%) phosphoric acid H_3PO_4 , and 80.1 parts H_2O , by weight. Approximately 14% ammonium phosphate pickup was needed in the dried paperboard to provide the required fire retardance. When the 14% ammonium phosphate pickup was achieved, the increased dip times did not significantly improve this value.

This treatment was used for an earlier fire retardant program (ref 1) and was proven successful for the fiber containers. However, problems were encountered in finding a supplier of the treated paper and in producing the fiber containers. Because of the corrosive nature of the treatment, it was not possible to find a company that supplied ammonium-phosphate-treated paperboard or that would treat virgin paperboard making it necessary for the contractor of the fiber container to treat the paper on a pilot scale. In production, winding the paperboard was difficult due to the unusually high moisture content which also caused delamination in the finished containers.

The second fire retardant considered for paper was antimonytrioxide. Paper treated with this agent was found to be available through the Spalding Paper Co. designated as Spalding LFR. The paper was treated in a one-step process during manufacture.

Because of the availability, construction feasibility, and the results from the laboratory scale fire tests, all the fiber container inner wraps were constructed from Spalding LFR antimonytrioxide treated paperboard.

Laboratory Evaluation

Surface Burn Testing

To evaluate fire-retardant-paper products, a comparative test was needed to analyze surface burning associated with paperboard in a fiber container configuration. A standard test fitting this description was not available in the literature. Most of the fire tests available for paper products dealt with edge burning, therefore, a surface-burn test was developed which would give adequate reproducible results (fig 15). The test is performed by exposing treated paper samples to a burner flame for specified periods of time with the sample angle and thickness, the flame time, and the distance of the flame to the sample held constant. The flame time is increased until a sample ignites and burns when the flame is withdrawn. A new sample is used for each flame time.

Physical Testing

The two tests used for structural evaluation of the fire-retardant-fiber container were a metal-end-pull test that is part of the acceptance testing conducted at the contractor's plant and a ring compression test.

The metal-end-pull test is performed to determine how well the metal end is secured to the outer and cover tube which is a function of the crimp depth and paper strength and is conducted in accordance with military specification MIL-C-2439D (para 4.4.3).

The ring compression test was accomplished with the use of a Reible compression machine with the purpose of determining the comparable hoop strength between standard fiber container sections and fire-retardant fiber container sections. The hoop strength is a function of the paper strength and adhesives used.

FIELD TESTS ON FIRE RETARDANT PACK (BOX AND FIBER CONTAINER)

Cookoff Fire Test

Cookoff fire tests were performed to evaluate the comparative thermal insulation properties between the standard pack, untreated fiber container and box, and the fire retardant pack which consists of a treated fiber container and box.

Various combinations, alternating treated boxes with standard fiber containers and untreated boxes with fire retardant fiber containers, were also tried.

A cookoff apparatus was constructed with six propane burners connected to a manifold, all protected by a heavy steel plate with holes cut for the burners (fig. 16). The test was conducted by suspending a box, containing one 105-mm M490 tank training round in a fiber container and one empty fiber container over the cookoff assembly, so that the cartridge case of the round was directly over the burners (fig. 17). The burners were then ignited, and the time for the propellant in the cartridge case to cookoff was recorded.

Simulated Pallet Fire Test

A simulated pallet fire test was conducted to determine the effectiveness of the fire retardant packaging in containing an ammunition fire in a stockpile environment.

The test was performed using a 2 x 5 pallet array instead of the usual 3 x 5 or 3 x 4 pallet array to save on the limited packaging and ammunition available for testing. The 2 x 5 pallet array included ten boxes, twenty 105-mm tank rounds packed in 20 fiber containers, and one pallet situated in an open-faced steel enclosure. (The steel enclosure simulated the containment of an ammunition stockpile.) A cube MAT consisting of high-explosive backed 1/4-inch, 30-grain steel fragments was used as the initiation source and was set back approximately 30 feet from the pallet to insure penetration of two of the cartridge cases of tank rounds in front of the array (fig. 18).

The criteria for good performance in this test were that there would be no additional cookoffs due to burning of the packaging materials other than those initiated by the fragments.

Self-extinguishing of the packaging materials soon after consumption of the burning propellant or high-explosive was also desirable.

RESULTS

Laboratory Tests on Fire Retardants for Wood

Crib Testing

All three fire retardants performed well in this test with some small differences in the important parameters of weight loss versus time and flame-out time (fig. 19). The Fire-X treatment had the least average weight loss per unit time and also had the quickest average flameout time. The Flame-Proof treatment

had less average weight loss than the NCX treatment but had the longest flameout times.

Leach Testing

After the leaching test, only the Fire-X-treated wood retained significant fire retardant properties, while the Flame-Proof and NCX-treated wood burned like untreated wood when ignited (fig. 19). The results (table 2) indicated that with a less severe leaching test and shorter leach time, the NCX-treated wood probably would have retained its fire retardant properties.

Physical Testing, Wirebound Boxes

The results from the destructive drop-test series showed that the type of damage to the boxes was very dependent on whether the boxes were treated or untreated. Damage characteristic of the treated boxes included cracking, delamination, and breaking of the wood along the wire lines of the box indicating fragility of the wood (figs. 20 and 21). The percentage of fragility due to the inferior plywood used (5 ply versus 3 ply for the untreated boxes) and the percentage due to the treatment could not be determined. However, there were differences in the degree of damage to the treated boxes depending on the treatment used (table 3). Even though parts of the treated boxes broke off delaminated, the boxes usually remained intact and protected the rounds inside. The untreated boxes fared better as far as the wood is concerned but still exhibited damage at the cleated ends where the nails had a tendency to pull out (figs. 22 and 23).

Preservative Testing, Panama

After the first three months of testing, the Fire-X treated and NCX treated boxes showed less signs of decay than the Flame-Proof treated or untreated boxes. To quantify the results, the boxes in each pallet array were rated for decay from 0 (good) to 5 (failure) with "good" indicating no decay and "failure" indicating that the box is falling apart. The results (app), although inconclusive at this point in the test, show that the Fire-X treated boxes fared quite well (fig. 24) and compared favorably with the results for boxes treated with pentachlorophenol, the preservative presently used by the Army. The pentachlorophenol-treated boxes, however, have been exposed for 6 months compared to 3 months for the Fire-X boxes. The NCX treated boxes, though not quite as good as the Fire-X, did much better than the Flame-Proof or the untreated boxes (fig. 25).

Table 2. Results from ASTM crib tests conducted on wood cut from treated 105-mm wirebound boxes

Sample	Test	Initial weight (g)	Final weight (g)	Weight loss (g)	Weight loss (%)	Flame-out time (sec)
NCX	1	253.7	227.3	26.4	10.41	225
	2	247.4	222.4	25.0	10.11	148
	3	237.7	216.9	20.8	8.75	195
NCX Leached	1	250.6	*	*	*	1092
	2	222.8	*	*	*	--
Fire-X	1	260.1	240.3	19.8	7.61	194
	2	242.9	223.1	19.8	8.15	195
	3	263.7	241.5	22.2	8.42	226
	4	327.1	304.8	22.3	6.82	185
Fire-X Leached	1	248.5	223.5	25.0	10.06	207
	2	240.0	209.0	31.0	12.92	280
Flame-Proof	1	245.7	220.7	25.0	10.18	251
	2	251.4	229.6	21.8	8.68	280
	3	255.0	226.3	28.7	11.25	233
	4	290.3	266.1	24.2	8.34	226
Flame-Proof Leached	1	225.3	*	*	*	1014
	2	235.4	*	*	*	568
Untreated	1	281.5	*	*	*	--
	2	259.8	*	*	*	1053
Untreated Leached	1	257.7	*	*	*	--
	2	264.9	*	*	*	838

* Burned completely.

Table 3. Data for drop test sequence on 105-mm wirebound boxes

Treatment	Drop tests	Orientation and damage														
		3-ft flat drop				2-ft flat drop				3-ft corner drop				7-ft drop damage		
		Bottom	Top	R-side	L-side	Bottom	Top	R-side	L-side	1	2	3	4	Flat	Corner	
NCX	4	+	+	+	+	+	+	+	+	+	+	+	+	-	-	
		+	+	+	+	+	+	+	+	**	**	***	***	**	**	
		+	+	+	+	+	+	*	+	*	*	*	*	**	**	
		+	+	+	+	+	+	+	+	**	***	**	**	**	***	***
Fire-X	4	+	+	*	+	+	+	+	+	+	+	+	+	-	-	
		+	*	+	+	+	+	+	+	*	**	***	***	***	***	
		+	+	+	+	+	+	+	+	**	**	**	**	**	**	**
		+	+	+	+	+	+	+	+	*	*	*	*	**	**	**
Flame-Proof	4	+	+	+	+	+	+	+	+	+	*	+	+	-	-	
		+	*	+	+	+	+	+	+	**	*	**	**	***	***	
		+	+	+	+	+	+	+	+	*	*	*	*	***	***	
		+	+	+	+	+	+	+	+	*	**	**	**	***	***	
Untreated	4	+	+	+	+	+	+	+	+	+	+	+	+	-	-	
		+	+	+	+	+	+	+	+	*	*	*	*	*	*	
		+	+	+	+	+	+	+	+	*	*	*	*	**	**	
		+	+	+	+	+	+	+	+	*	*	*	*	**	**	

+ = No damage
 * = Minimal damage
 ** = Significant damage
 *** = Major damage
 - = Test discontinued

Laboratory Tests on Fire Retardants for Paper

Surface Burn Test, Paperboard

Both fire retardant treatments for paper in the surface burn test were self-extinguishing. However, the antimonytrioxide treated paperboard had a longer ignition time than the ammonium phosphate treated paperboard (table 4).

Table 4. Results from surface burn tests

<u>Treatment</u>	<u>Time to ignition (sec)</u>	<u>Duration of burn (sec)</u>
Untreated	15	60
Ammonium phosphate	45	2
Antimonytrioxide	60	1

Metal-End-Pull Test, Fire Retardant Fiber Container

The minimum removal force for class 1, 26-gage metal in accordance with military specification MIL-C-2439D is 800 lb; the removal force necessary for the metal ends on the fire-retardant fiber containers was approximately 1200 lb.

Compression Test, Fire Retardant Fiber Container

The results from the ring compression test showed that the fire-retardant fiber container was stronger than the standard fiber container. When the outer tubes and neck tubes were tested individually, the standard outer tube (which has asphalt in its composition) was close in strength to the fire-retardant outer tube which does not contain asphalt. A truer comparison in the strength of the standard paperboard versus the fire retardant paperboard is shown by the results for the neck tubes (table 5).

Table 5. Results from compression tests on 6 1/4-in. fiber container sections tested to a 1-in. deflection

<u>Tube</u>	<u>Wall thickness (in.)</u>	<u>Maximum load (lb)</u>
Standard outer tube*	0.17	80
Standard neck tube	0.25	75
Standard outer and neck tube	0.42	150
Fire retardant outer tube	0.17	84
Fire retardant neck tube	0.25	117
Fire retardant outer and neck tubes	0.42	186

* Outer tube stiffness due to presence of asphalt in the composition of the tube.

Field Tests on Fire Retardant Pack

Cookoff Fire Field Tests

The results show a definite relationship between increased fire-retardant protection and extended cookoff time. The time before cookoff was approximately doubled by replacing the standard box with a fire retardant box while it was extended a significant amount more by replacing the standard fiber container with a fire-retardant fiber container (table 6). Variations in the cookoff times, especially for tests 5 and 6, may have been due to wind conditions since these tests were conducted on different days.

The poor performance of the Flame-Proof treated boxes in the field tests was probably caused by an observed leaching of the fire retardant from exposure to rain during outside storage.

Table 6. Results from cookoff fire test to determine insulating properties of treated packaging materials

<u>Test</u>	<u>Box</u>	<u>Container</u>	<u>Cookoff time (min)</u>
1	Untreated	Untreated	20
2	Flame-Proof	Untreated	32
3	NCX	Untreated	39
4	Fire X	Untreated	40
5	Fire X	Treated	49
6	NCX	Treated	58

Simulated Pallet Fire Test

The results (table 7) for the tests on the standard untreated 105-mm pack clearly show that the packaging catches fire after initiation and supplies enough fuel to cookoff the remaining rounds except for those which were thrown clear. For the complete fire retardant pack, only the initiated rounds were lost after which the propellant was consumed and the fire went out (figs. 28 and 29). The results for various combinations of partially treated packs are as follows:

1. Treated pallet, treated boxes, and untreated fiber containers. There were some cookoffs after the initiation. The number of cookoffs depend on the number and violence of the rounds initiated since these reactions break apart adjacent boxes exposing the untreated fiber containers to the subsequent propellant or high-explosive fire.

2. Untreated pallet, untreated boxes, and fire-retardant fiber containers. The untreated boxes and pallet provided enough fuel energy to cookoff the rounds remaining after initiation. There was a difference, however, in that the first cookoff after initiation took place at 39 minutes versus 12 minutes for the standard pack.

3. Treated pallet, treated boxes, and partially treated fiber container. The neck tubes in the fire-retardant fiber containers were replaced with standard untreated neck tubes. The results for these tests were similar to the results for the complete fire retardant pack. This shows that only the outer layers of the fiber container have to be treated for the pack to still be self-extinguishing.

Table 7. Results from simulated pallet fire test

<u>Pallet</u>	<u>Box</u>	<u>Tubes</u>		<u>Ammunition</u>		<u>Round</u>		
		<u>Outer</u>	<u>Inner</u>	<u>Quantity</u>	<u>Type</u>	<u>Initiated</u>	<u>Cookoff</u>	<u>Intact</u>
STD	STD	STD	STD	20	M467	2	16	2
Fire-X	Fire-X	STD	STD	20	M456	3	6	11
Flame-Proof	Flame-Proof	STD	STD	20	M456	2	15	3
NCX	NCX	STD	STD	20	M456	2	3	15
Fire-X	Fire-X	FRD	FRD	20	M467	2	0	18
STD	STD	FRD	FRD	20	M467	3	16	1
Fire-X	Fire-X	FRD	STD	15 5	M467 M490	3	0	17
NCX	NCX	FRD	STD	15 5	M467 M490	1	0	19

STD - Standard untreated

FRD - Fire retardant

CONCLUSIONS

The results from this test program demonstrate that stockpiles of ammunition packaged with untreated materials are vulnerable to fire spread and subsequent loss of large amounts of ammunition due to a localized initiation source. It also proves that the environment created by burning propellant and high-explosive will not set fire to treated packaging; therefore, limiting the damage to the rounds which react on initiation. The treated packaging materials will thermally decompose when exposed to the high temperatures of burning propellant or high explosive, but will self-extinguish when the heat source is removed.

The fire-retardant-treated materials used in these tests exhibit excellent mechanical properties, and there should be no hesitation in using them in an end item system. In addition, as an added bonus, some of the fire retardant treatments also have good preservative properties.

RECOMMENDATIONS

It is recommended that the use of fire-retardant-treated ammunition and propellant packaging be evaluated as a means of reducing the minimum permissible distances between the potential explosion sites specified in the quantity-distance tables for stored munitions and, therefore, providing increased storage capacity in present and future supply sites and magazines.

REFERENCES

1. L. Teitell and H. Reeves, "Fire Retardant Packaging for Artillery Ammunition," Memo Report No. 2490, U.S. Army Ballistic Research Laboratory, Aberdeen Proving Ground, MD, August 1975.
2. H. Reeves and L. Teitell, "Packaging to Improve Cook-Off Characteristics of 155mm Propelling Charges," Memo Report No. 2850, U.S. Army Ballistic Research Laboratory, Aberdeen Proving Ground, MD, July 1978.

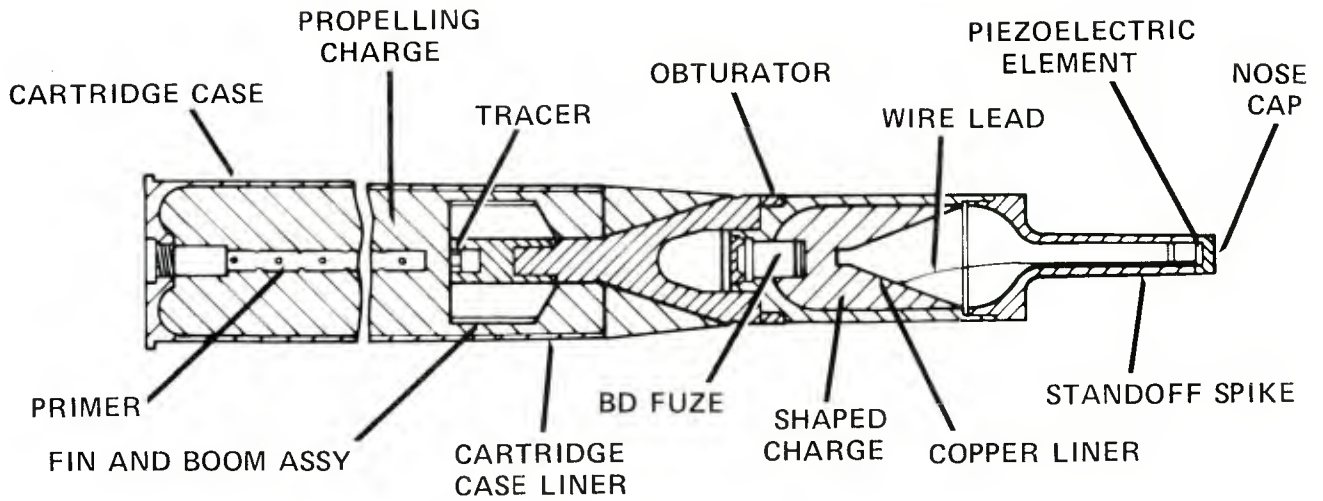

Figure 1. 105-mm HEAT-T, M456 series

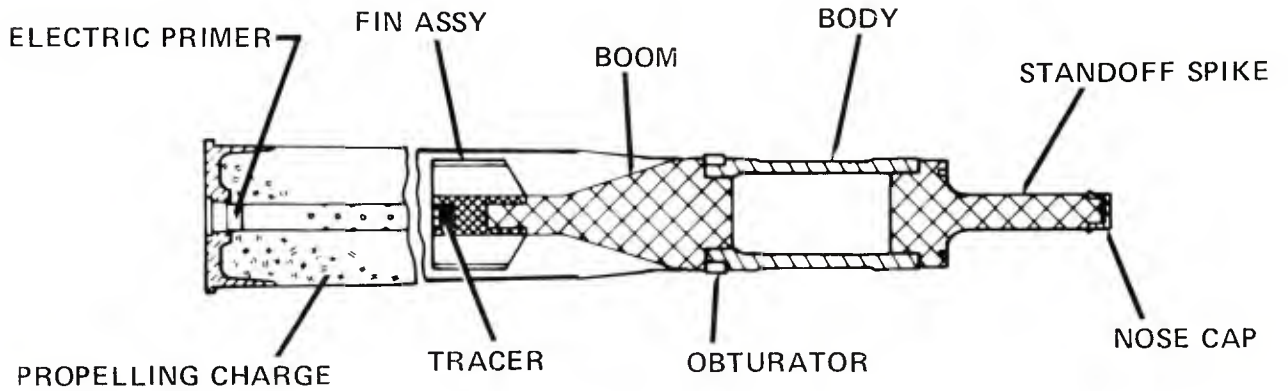

Figure 2. 105-mm TP-T, M490

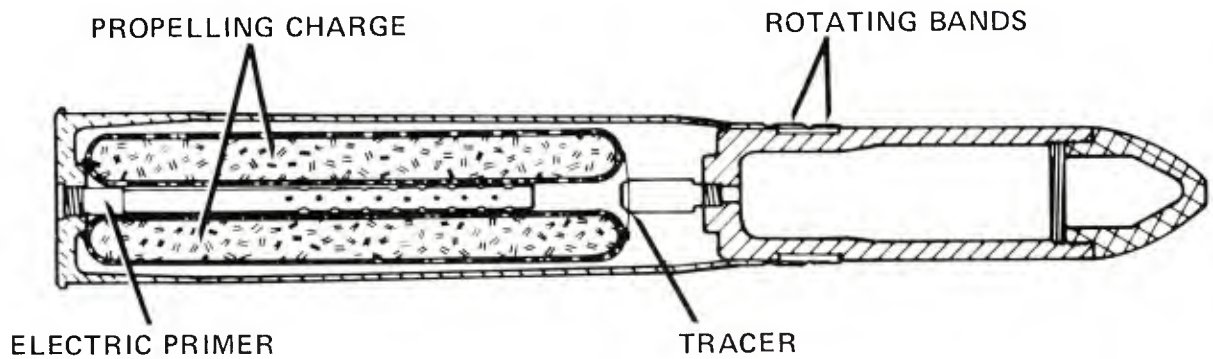

Figure 3. 105-mm TP-T, M467

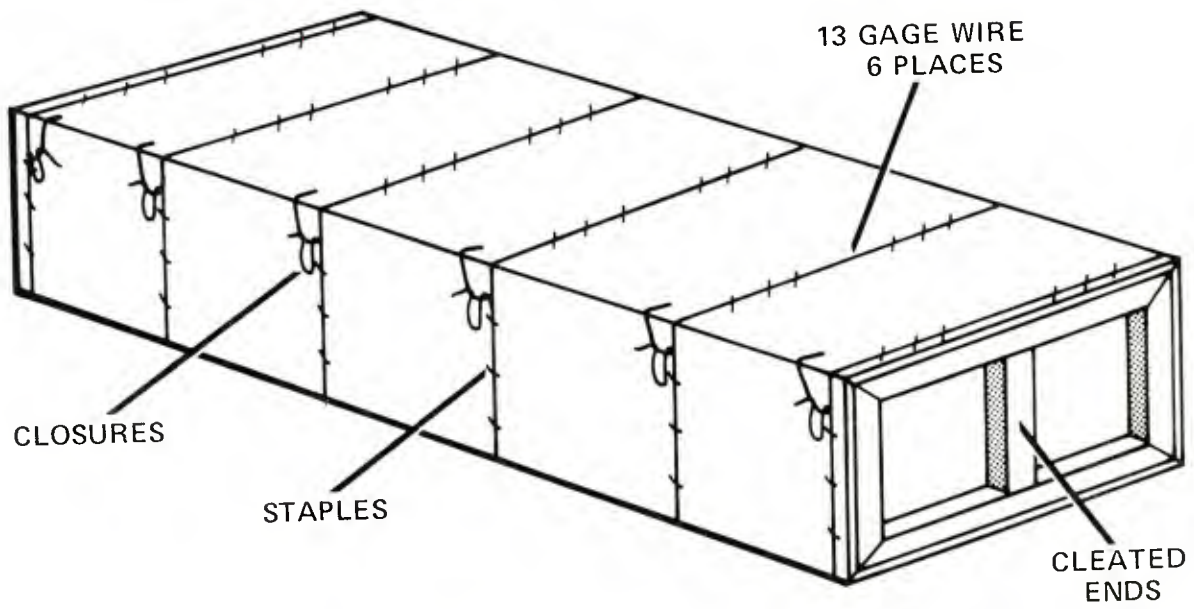

Figure 4. Wirebound box

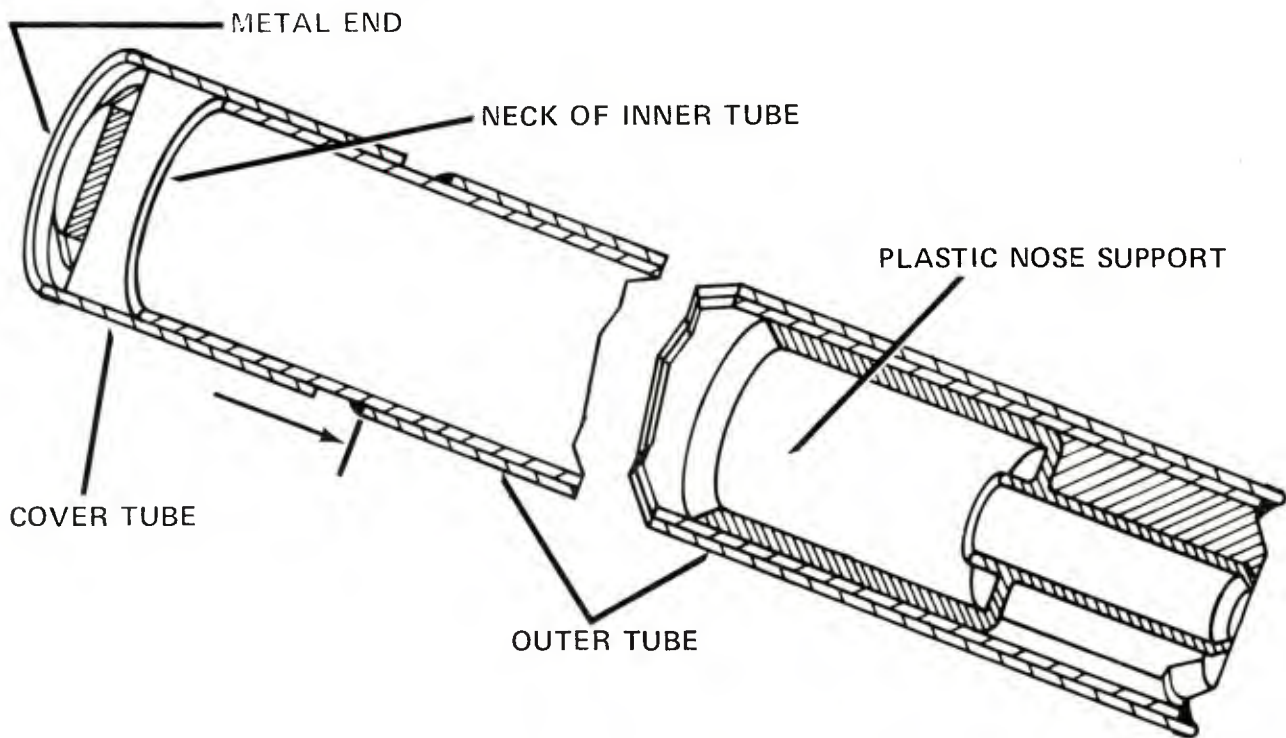

Figure 5. Standard fibre container for 105-mm tank rounds

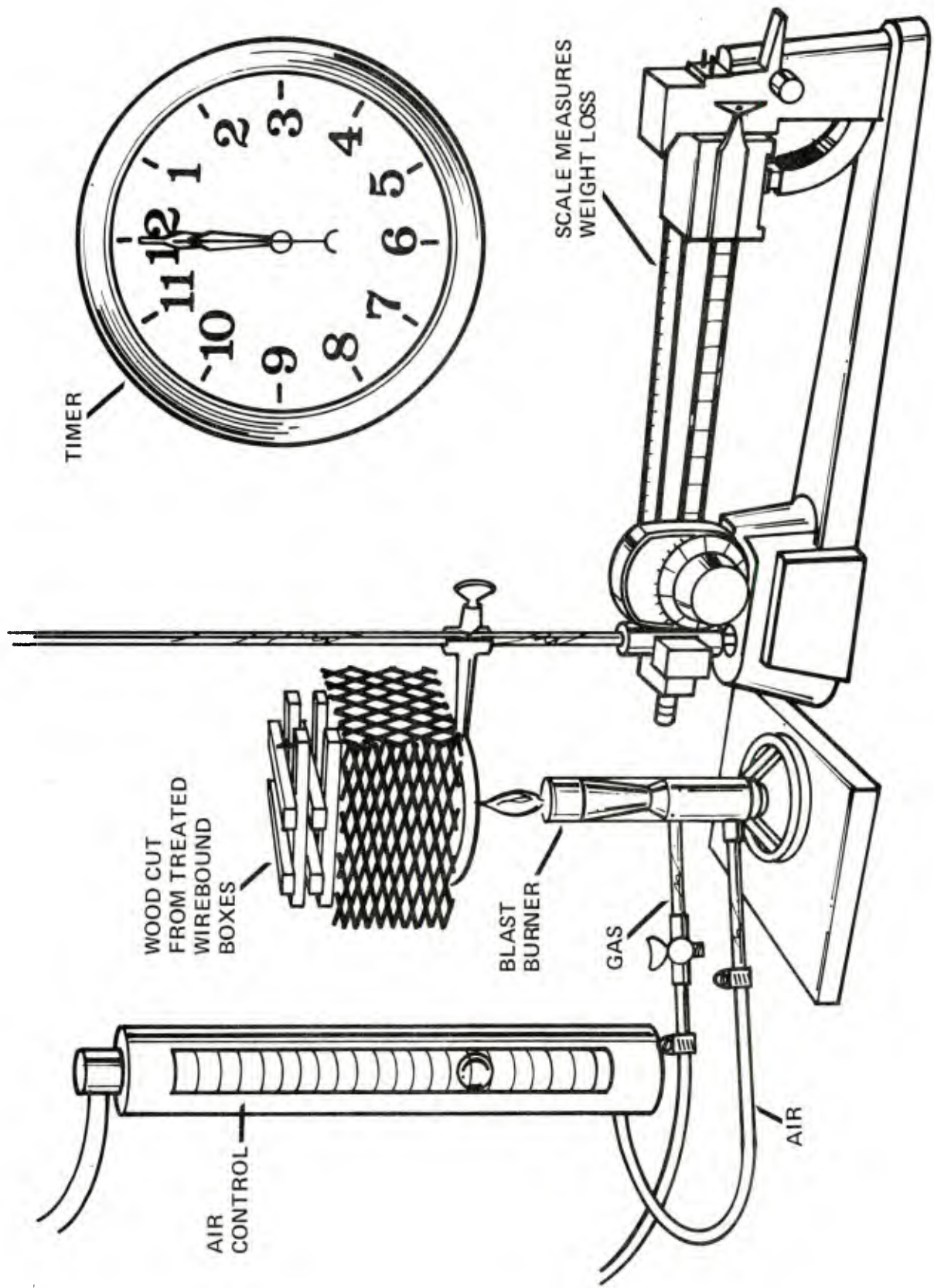

Figure 6. ASTM standard crib test for testing combustible properties of treated wood



Figure 7. Crib test performed on untreated wood--5 seconds before burner shutoff



Figure 8. Crib test performed on untreated wood--68 seconds after burner shutoff



Figure 9. Crib test performed on fire-retardant treated wood--5 seconds before burner shutoff



Figure 10. Crib test performed on fire-retardant treated wood--10 seconds after burner shutoff

METHOD 5830 FROM FEDERAL SPECIFICATIONS
 STANDARD TEST METHODS FOR TEXTILES
 LEACHING RESISTANCE OF CLOTH

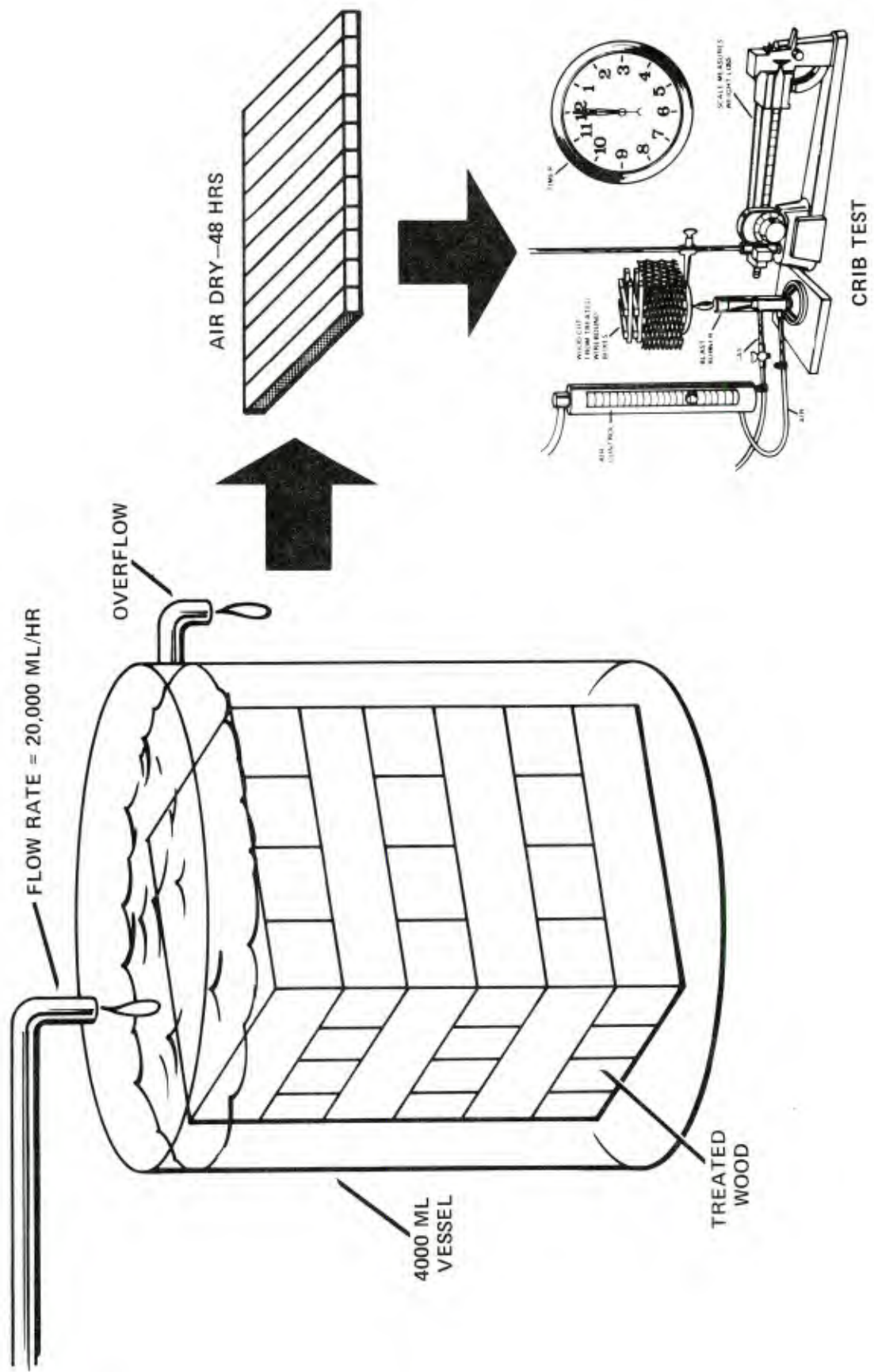

Figure 11. Seven-day leaching test

ONE BOX EACH TREATMENT LOADED WITH
 2 INERT 105MM M490 CARTRIDGES DROPPED
 ACCORDING TO FOLLOWING SERIES:

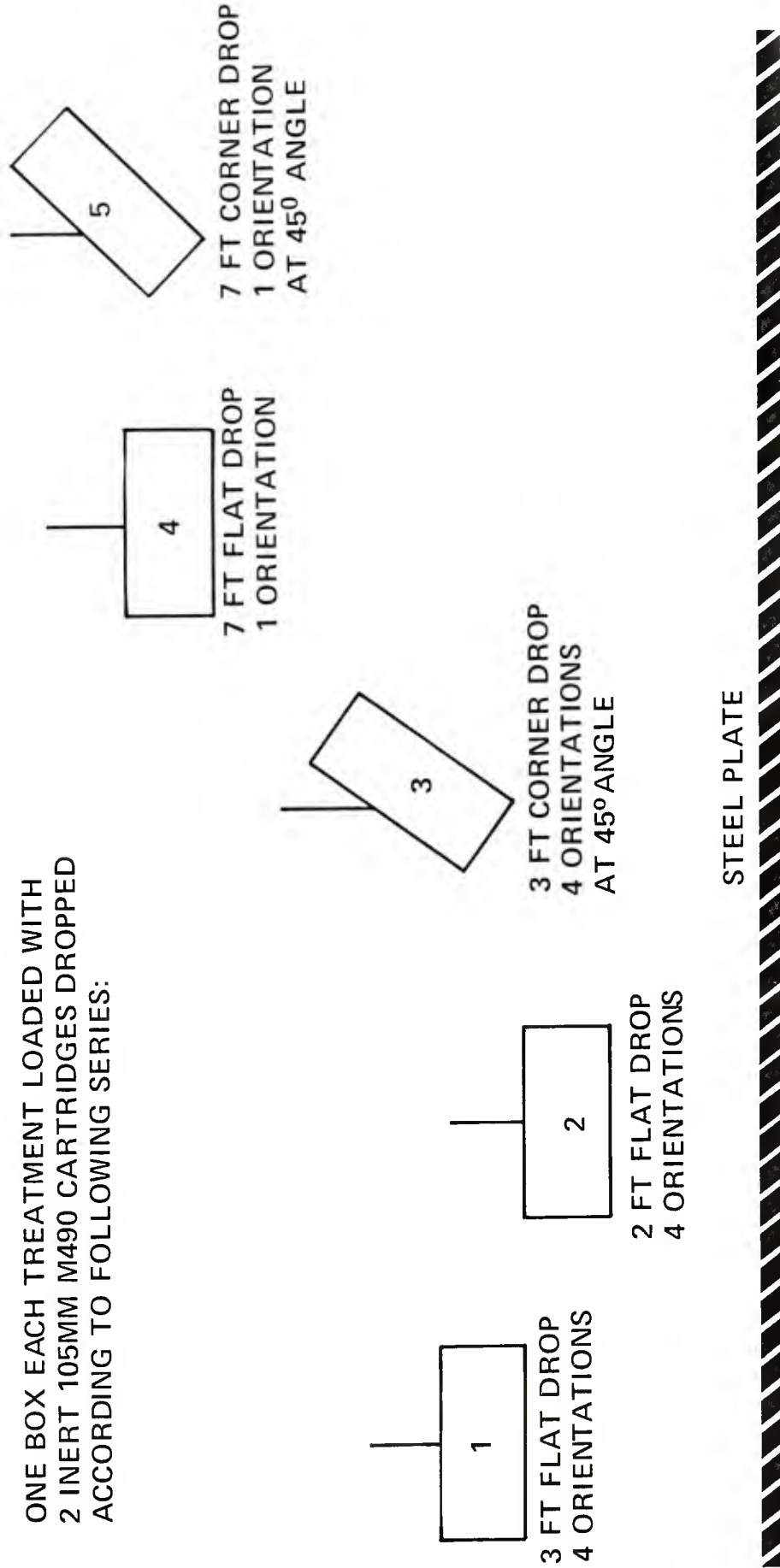

Figure 12. Drop test series for fire-retardant wirebound box



Figure 13. Exposure site at Skunk Hollow



Figure 14. Exposure site at Chiva-Chiva

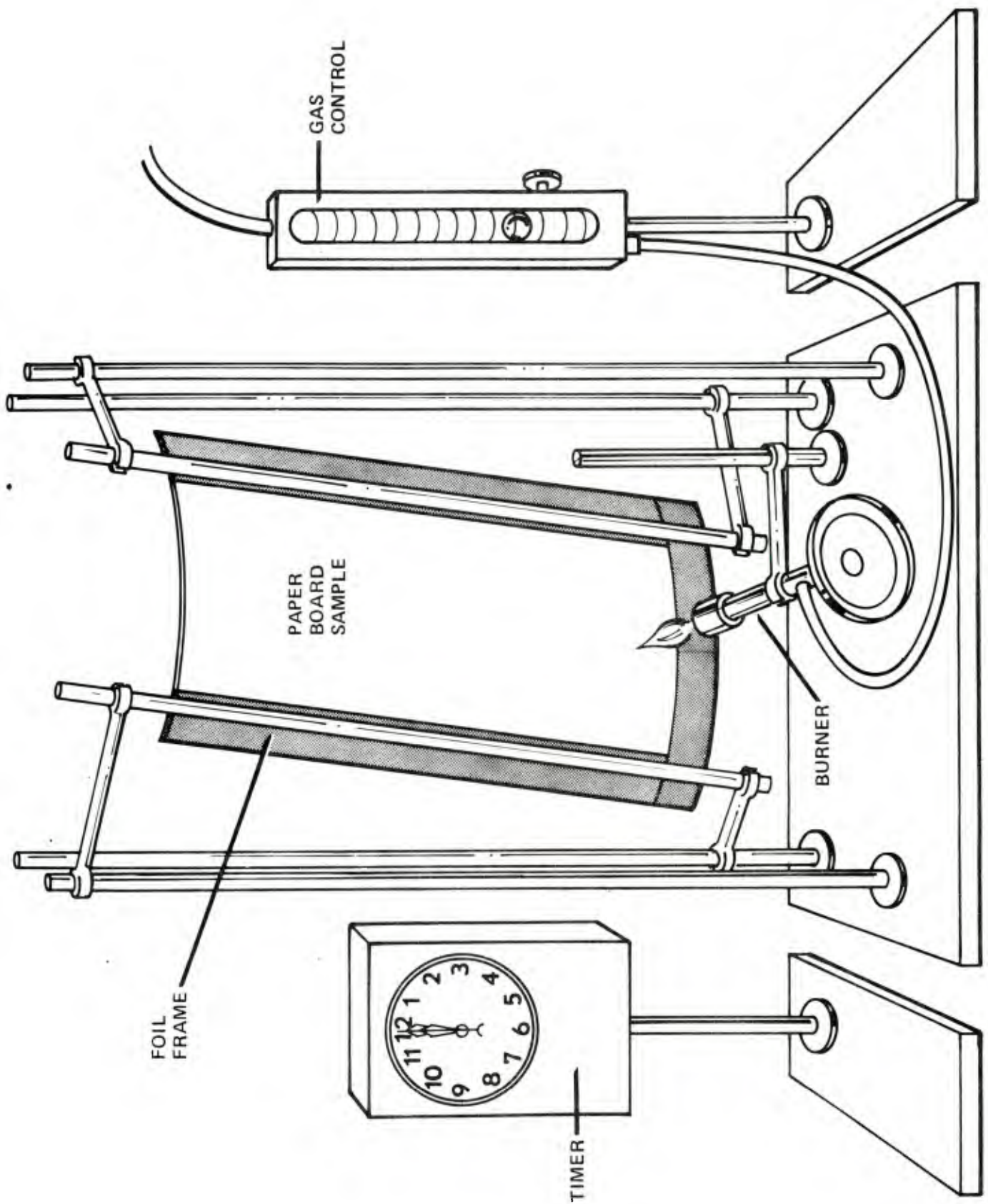

Figure 15. Surface burn test setup for paper products

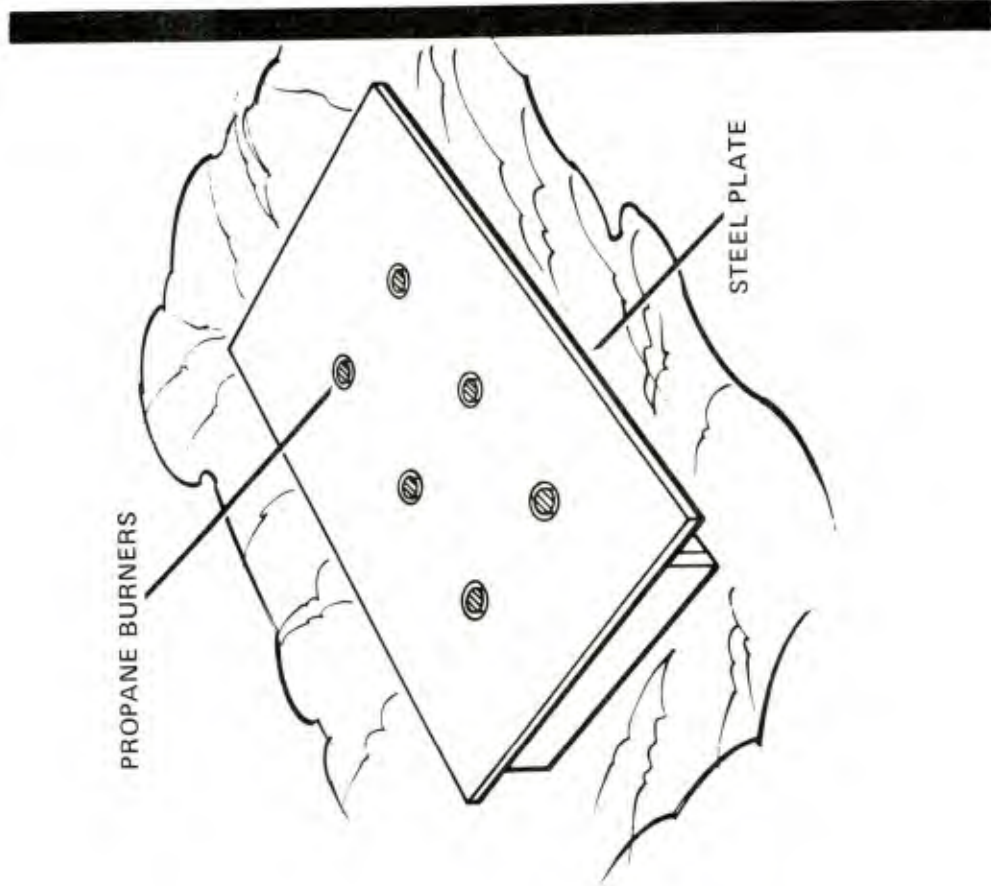

Figure 16. Cookoff apparatus

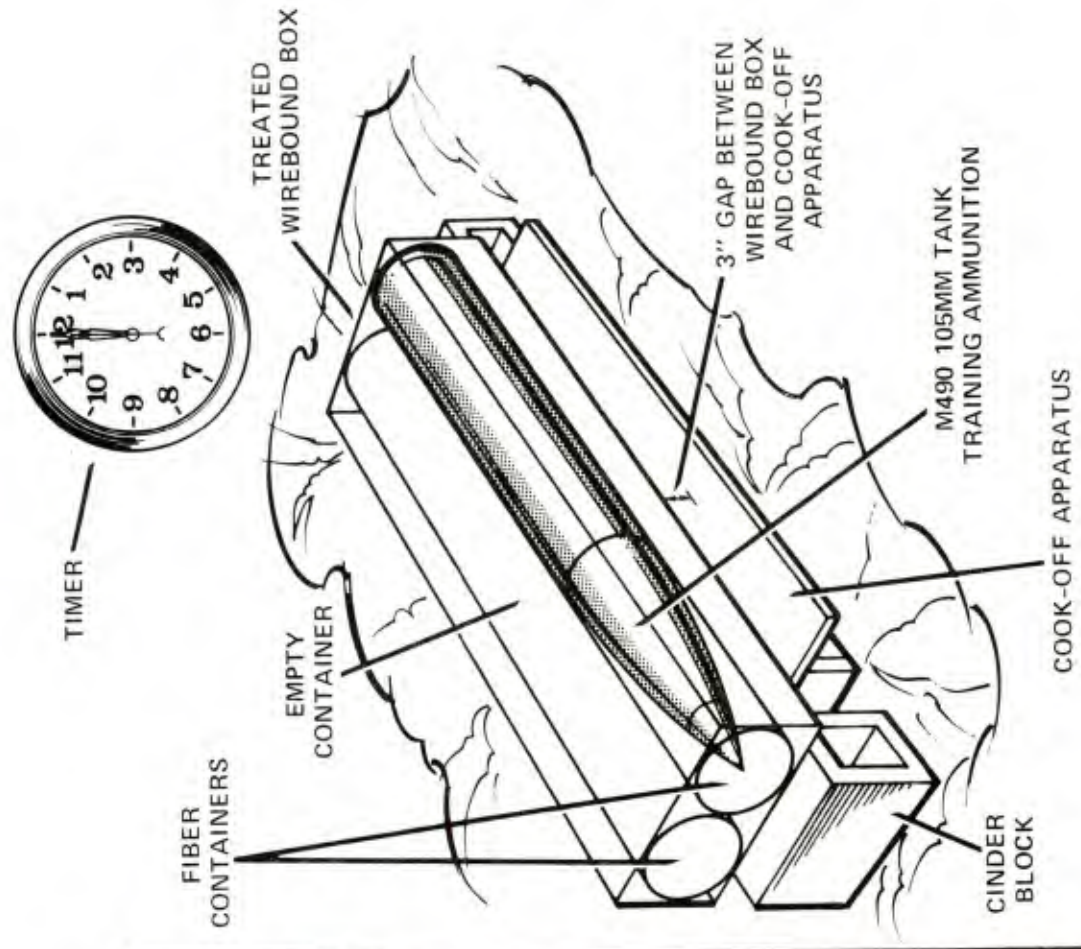

Figure 17. Cookoff test setup

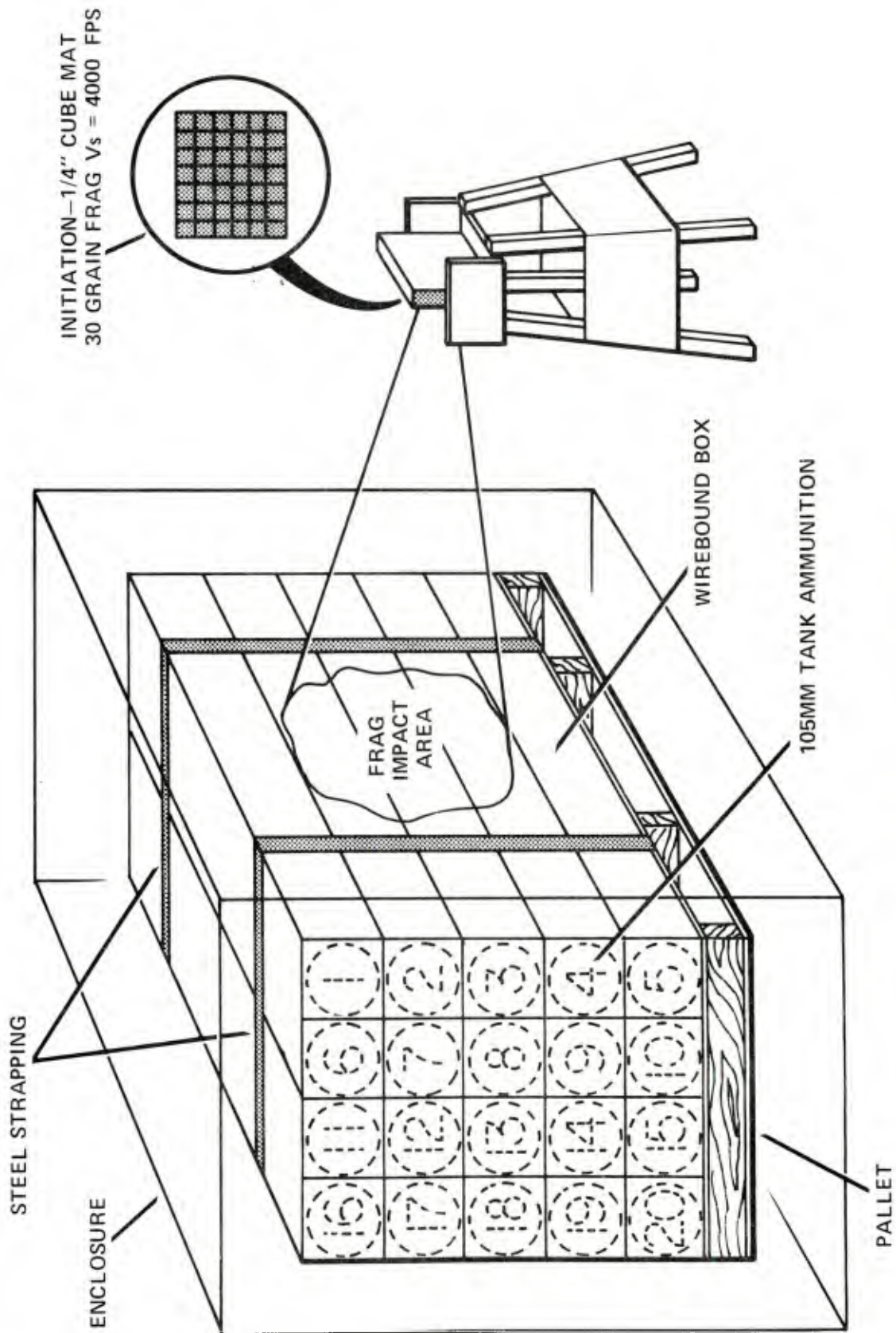

Figure 18. Pallet fire test

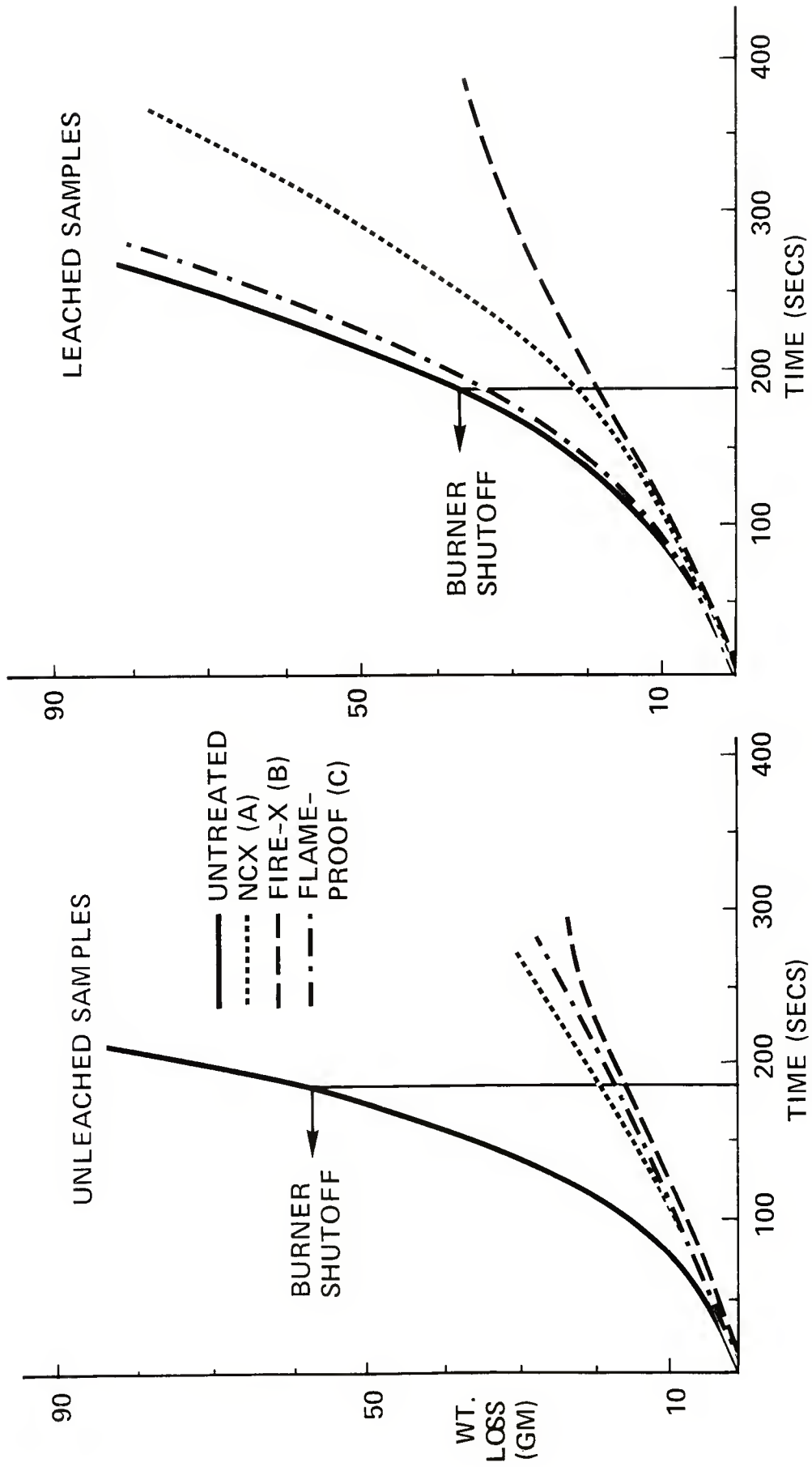

Figure 19. Crib test results for fire-retardant-treated wood



Figure 20. Progression of damage to a fire-retardant-treated box during the drop-test series



Figure 21. Fire-retardant-treated box after completion of the drop-test series



Figure 22. Progression of damage to an untreated box during the drop-test series



Figure 23. Untreated box after completion of the drop-test series



Figure 24. Untreated box after a 3-month exposure



Figure 25. Fire-retardant-treated box after a 3-month exposure



Figure 26. Results from a simulated pallet fire test using untreated packaging



Figure 27. Debris remaining after a simulated pallet fire test using untreated packaging



Figure 28. Results from a simulated pallet fire test using fire-retardant treated packaging



Figure 29. Intact rounds remaining after a simulated pallet fire test using fire-retardant treated packaging

APPENDIX

RESULTS OF PANAMA EXPOSURE TESTS

PANAMA EXPOSURE TEST RATING VALUES FOR WIREBOUND BOXES

- 0 - GOOD
- 1 - SUSPICIOUS
- 2 - DECAY IN SPOTS
- 3 - DECAY PRESENT - BUT STRENGTH OK
- 4 - GENERAL DECAY - LIKELY TO FAIL DROP
- 5 - FAILURE

WIREBOUND BOX ARRAY ADDRESSES

1-1	2-1	3-1	4-1	5-1	6-1
1-2	2-2	3-2	4-2	5-2	6-2
1-3	2-3	3-3	4-3	5-3	6-3
1-4	2-4	3-4	4-4	5-4	6-4
1-5	2-5	3-5	4-5	5-5	6-5

A. PANAMA SKUNK HOLLOW LOCATION

I. Untreated 105mm Wirebound Boxes-After 3 Months

(a) Stack Array 5 x 4

<u>BOX NO.</u>	<u>RATING</u>					
	<u>S1</u>	<u>S2</u>	<u>S3</u>	<u>S4</u>	<u>E1</u>	<u>E2</u>
1-1	1	1	1	1	1	1
1-2	1	1	2	2	1	1
1-3	2	2	2	2	2	2
1-4	1	1	1	1	1	1
2-1	2	2	2	2	2	2
2-2	2	2	2	2	2	2
2-3	3	3	3	3	3	3
2-4	2	2	2	2	2	2
3-0	3	3	3	3	3	3
3-1	2	2	2	2	2	2
3-2	1	1	1	1	1	1
3-3	1	1	1	1	1	1
3-4	1	1	1	2	1	1
4-0	2	2	2	3	2	2
4-1	3	3	3	3	3	3
4-2	3	3	3	3	3	3
4-3	2	2	2	2	2	2
4-4	1	1	1	1	1	1
5-1	2	2	2	2	2	2
5-2	3	3	2	2	2	2
5-3	3	3	3	3	3	3
5-4	2	2	2	3	3	3

II. Penta Treated 105mm Wirebound Boxes-After 6 Months

(a) Stack Array - 3 x 3

<u>BOX NO.</u>	<u>RATING</u>					
	<u>S1</u>	<u>S2</u>	<u>S3</u>	<u>S4</u>	<u>E1</u>	<u>E2</u>
1-1	0	0	0	0	0	0
1-2	0	0	0	0	0	0
1-3	0	0	0	0	0	0
2-1	0	0	0	0	0	0
2-2	0	0	0	0	0	0
2-3	0	0	0	0	0	0
3-1	0	0	0	0	0	0
3-2	0	0	0	0	0	0
3-3	0	0	0	0	0	0

(b) Stack Array 3 x 3

<u>BOX NO.</u>	<u>RATING</u>					
	<u>S1</u>	<u>S2</u>	<u>S3</u>	<u>S4</u>	<u>E1</u>	<u>E2</u>
1-1	0	0	0	0	0	0
1-2	0	1	0	0	0	0
1-3	0	0	0	0	1	0
2-1	0	0	0	0	0	0
2-2	0	0	0	0	0	0
2-3	0	0	0	0	0	0
3-1	0	0	0	0	0	0
3-2	0	0	0	0	0	0
3-3	0	0	0	0	0	0

(c) Stack Array 3 x 3

<u>BOX NO</u>	<u>RATING</u>					
	<u>S1</u>	<u>S2</u>	<u>S3</u>	<u>S4</u>	<u>E1</u>	<u>E2</u>
1-1	0	0	0	0	0	0
1-2	0	0	0	0	0	0
1-3	0	0	0	0	0	0
2-1	0	0	0	0	0	0
2-2	0	0	0	0	0	0
2-3	0	0	0	0	0	0
3-1	0	0	0	0	0	0
3-2	0	0	0	0	0	0
3-3	0	0	0	0	0	0

III Fire-X Treated 105mm Wirebound Boxes After 3 Months

(a) Stack Array 6 x 5

<u>BOX NO.</u>	<u>RATING</u>					
	<u>S1</u>	<u>S2</u>	<u>S3</u>	<u>S4</u>	<u>E1</u>	<u>E2</u>
1-1	0	0	0	0	0	0
1-2	0	0	3	2	0	0
1-3	0	0	0	0	0	0
1-4	0	0	0	0	0	0
1-5	0	0	0	0	0	0
2-1	0	0	0	0	0	0
2-2	0	0	0	0	0	0
2-3	0	0	0	0	0	0
2-4	0	0	0	0	0	0
2-5	0	0	0	0	0	0
3-1	0	0	0	0	0	0
3-2	0	0	0	0	0	0
3-3	0	0	0	0	0	0
3-4	0	0	0	0	0	0
3-5	0	0	0	0	0	0
4-1	0	0	0	0	0	0
4-2	0	0	0	0	0	0
4-3	0	0	0	0	0	0
4-4	0	0	0	0	0	0
4-5	0	0	0	0	0	0
5-1	0	0	0	0	0	0
5-2	0	0	0	0	0	0
5-3	0	0	0	0	0	0
5-4	0	0	0	0	0	0
5-5	0	0	0	0	0	0
6-1	0	0	0	0	0	0
6-2	0	0	0	0	0	0
6-3	0	0	0	0	0	0
6-4	0	0	0	0	0	0
6-5	0	0	0	0	0	0

IV NCX Treated 105mm Wirebound Boxes After 3 Months

(a) Stack Array 6 x 5

<u>BOX NO.</u>	<u>RATING</u>					
	<u>S1</u>	<u>S2</u>	<u>S3</u>	<u>S4</u>	<u>E1</u>	<u>E2</u>
1-1	0	0	0	0	0	0
1-2	1	2	1	2	1	1
1-3	1	1	1	1	1	1
1-4	1	2	2	2	1	1
1-5	1	2	2	1	1	1
2-1	2	2	1	2	1	1
2-2	1	1	2	2	1	1
2-3	2	2	2	2	1	1
2-4	1	1	1	2	1	1
2-5	1	2	1	0	1	1
3-1	2	1	1	1	1	1
3-2	2	2	2	1	1	1
3-3	2	2	2	1	1	1
3-4	1	1	1	1	1	1
3-5	0	0	2	1	1	1
4-1	2	3	2	2	1	1
4-2	1	2	1	1	1	1
4-3	1	1	1	1	1	1
4-4	1	2	2	2	1	1
4-5	1	1	1	1	1	1
5-1	2	1	1	1	1	1
5-2	2	2	2	2	1	1
5-3	1	1	1	1	1	1
5-4	1	2	1	2	1	1
5-5	1	1	1	1	1	1
6-1	1	1	1	1	1	1
6-2	1	1	0	1	1	1
6-3	2	2	2	1	1	1
6-4	2	2	1	1	1	1
6-5	1	1	1	1	1	1

V. Flameproof Treated 105mm Wirebound Boxes After 3 Months

(a) Stack Array 6 x 5

<u>BOX NO.</u>	<u>RATING</u>				<u>E1</u>	<u>E2</u>
	<u>S1</u>	<u>S2</u>	<u>S3</u>	<u>S4</u>		
1-1	1	1	1	2	2	2
1-2	2	2	2	3	2	2
1-3	2	2	2	2	2	2
1-4	1	2	2	3	2	2
1-5	2	2	2	3	2	2
2-1	2	2	2	3	2	2
2-2	2	2	2	2	2	2
2-3	2	2	2	3	2	2
2-4	2	2	2	2	2	2
2-5	2	2	2	2	2	2
3-1	2	2	2	2	2	2
3-2	2	2	2	2	2	2
3-3	2	3	2	3	2	2
3-4	2	2	2	3	2	2
3-5	2	3	2	2	2	2
4-1	2	3	3	3	2	2
4-2	3	3	3	3	2	2
4-3	2	3	2	2	2	2
4-4	2	2	2	3	2	2
4-5	2	3	3	3	2	2
5-1	2	2	2	3	2	2
5-2	2	3	2	2	2	2
5-3	2	2	2	2	2	2
5-4	2	3	2	2	2	2
5-5	2	3	2	3	2	2
6-1	2	1	1	2	2	2
6-2	2	2	3	3	2	2
6-3	2	3	2	2	2	2
6-4	2	3	2	3	2	2
6-5	2	3	2	3	2	2

DISTRIBUTION LIST

Commander
Armament Research and Development Center
U.S. Army Armament, Munitions and Chemical Command
ATTN: DRSMC-TSS(D) (5)
DRSMC-GCL(D)
DRSMC-LCU-S-P(D) (11)
Dover, NJ 07801

Administrator
Defense Technical Information Center
ATTN: Accessions Division (12)
Cameron Station
Alexandria, VA 22314

Director
U.S. Army Materiel Systems
Analysis Activity
ATTN: DRXSY-MP
DRXSY-S, R. Bailey
Aberdeen Proving Ground, MD 21005

Commander
Chemical Research and Development Center
U.S. Army Armament, Munitions and Chemical Command
ATTN: DRSMC-CLJ-L(A)
DRSMC-CLB-PA(A)
APG, Edgewood Area, MD 21010

Director
Ballistics Research Laboratory
Armament Research and Development Center
U.S. Army Armament, Munitions and Chemical Command
ATTN: DRSMC-BLA-S(A) H. Reeves
Aberdeen Proving Ground, MD 21005

Chief
Benet Weapons Laboratory, LCWSL
Armament Research and Development Center
U.S. Army Armament, Munitions and Chemical Command
ATTN: DRSMC-LCB-TL
Watervliet, NY 12189

Commander
U.S. Army Armament, Munitions and Chemical Command
ATTN: DRSMC-LEP-L(R)
Rock Island, IL 61299

Director
U.S. Army TRADOC Systems
Analysis Activity
ATTN: ATAA-SL
White Sands Missile Range, NM 88002

Commandant
U.S. Army Armor School
Ft. Knox, KY 40121

Commander
Naval Ammunition Depot, Earle
ATTN: WH-802
Colts Neck, NJ 07222

Chairman DOD Explosive Safety Board
Hoffman Bldg 1, Rm 856C
2461 Eisenhower Avenue
Alexandria, VA 22333

Director
DARCOM Ammo Center
ATTN: SARAC-DE
Savanna, IL 61704

Director
DARCOM Packaging Storage and
Containerization Center
ATTN: ADTSO-T
Tobyhanna Army Depot
Tobyhanna, PA 18466

Commander
U.S. Army Missile and Munitions
School and Center
ATTN: ATSK-CTD
Redstone Arsenal, AL 35809

Commander
U.S. Army Europe
APO New York 09403

Commander
Naval Sea Systems Command
ATTN: Code 03511, C. Pohler
Washington, DC 20362

Commander
Naval Sea Systems Command
ATTN: SEA-06G3
Washington, DC 20360

Commander
Naval Surface Weapons Center
ATTN: Technical Library
Silver Spring, MD 20910

Commander
Naval Weapons Center
ATTN: J. Pakulak
China Lake, CA 93555

Commander
Naval Ordnance Station
Indian Head, MD 20640

Commander
Marine Corps Development
and Education Command
ATTN: Plans and Studies Div
Firepower Div
Quantico, VA 22314

AFSC
Andrews Air Force Base
Washington, DC 20331

AFAL
ATTN: MAJ R. Gilman
Eglin Air Force Base, FL 32542

Department of Transportation
Federal Railroad Administration
ATTN: Don Levine
2nd & V Streets, SW
Washington, DC 20590

Commander
Transportation Engineering Agency
ATTN: A. Ragunas
12388 Warwick Boulevard
P.O. Box 6276
Newport News, VA 23606

Commander
Military Traffic Management Command
NASSIF Building
Washington, DC 20315

Commander
U.S. Army Test and Evaluation Command
ATTN: DRSTE-SG-H
Aberdeen Proving Ground, MD 21005